

This operation guide describes installation, wiring, and other tasks required to make the controller ready for operation.
For details of each function, refer to the electronic manual. Manuals can be downloaded or viewed at the following URL.

<http://www.yokogawa.com/ns/ut/im/>

Contents

- Safety Precautions
- Model and Suffix Codes
- How to Install
- Hardware Specifications
- How to Connect Wires
- Terminal Wiring Diagrams

Introduction

Thank you for purchasing the UT35A, UT32A Digital Indicating Controller. This operation guide describes the basic operations of the UT35A and UT32A. The guide should be provided to the end user of this product.

Be sure to read this operation guide before using the product in order to ensure correct operation.

For details of each function, refer to the electronic manual. Before using the product, refer to the table of Model and Suffix Codes to make sure that the delivered product is consistent with the model and suffix codes you ordered. Also make sure that the following items are included in the package.

- Digital Indicating Controller (the model you ordered).....x1
- Set of Brackets.....x1
- Unit Label (L4502VZ).....x1
- Tag Label (L4502VE).....x1 (Only when ordered.)
- Operation Guide (this document).....x6 (A3 size) (Installation and Wiring, Initial Settings, Operations, and Parameters)

Target Readers

- This guide is intended for the following personnel;
- Engineers responsible for installation, wiring, and maintenance of the equipment.
- Personnel responsible for normal daily operation of the equipment.

1. Safety Precautions

The following symbol is used on the instrument. It indicates the possibility of injury to the user or damage to the instrument, and signifies that the user must refer to the operation guide or user's manual for special instructions. The same symbol is used in the operation guide and user's manual on pages that the user needs to refer to, together with the term "WARNING" or "CAUTION."



WARNING
Calls attention to actions or conditions that could cause serious or fatal injury to the user, and indicates precautions that should be taken to prevent such occurrences.



CAUTION
Calls attention to actions or conditions that could cause injury to the user or damage to the instrument or property and indicates precautions that should be taken to prevent such occurrences.

AC

AC/DC



The equipment wholly protected by double insulation or reinforced insulation.



Functional grounding terminals
(Do not use this terminal as a protective grounding terminal).

Note

Identifies important information required to operate the instrument.

Warning and Disclaimer

- YOKOGAWA makes no warranties regarding the product except those stated in the WARRANTY that is provided separately.
- The product is provided on an "as is" basis. YOKOGAWA assumes no liability to any person or entity for any loss or damage, direct or indirect, arising from the use of the product or from any unpredictable defect of the product.

Safety, Protection, and Modification of the Product

- In order to protect the system controlled by this product and the product itself, and to ensure safe operation, observe the safety precautions described in the operation guide. Use of the instrument in a manner not prescribed herein may compromise the product's functions and the protection features inherent in the device. We assume no liability for safety, or responsibility for the product's quality, performance or functionality should users fail to observe these instructions when operating the product.
- Installation of protection and/or safety circuits with respect to a lightning protector; protective equipment for the system controlled by the product and the product itself; foolproof or fail-safe design of a process or line using the system controlled by the product or the product itself; and/or the design and installation of other protective and safety circuits are to be appropriately implemented as the customer deems necessary.
- Be sure to use the spare parts approved by YOKOGAWA when replacing parts or consumables.
- This product is not designed or manufactured to be used in critical applications that directly affect or threaten human lives. Such applications include nuclear power equipment, devices using radioactivity, railway facilities, aviation equipment, air navigation facilities, aviation facilities, and medical equipment. If so used, it is the user's responsibility to include in the system additional equipment and devices that ensure personnel safety.
- Modification of the product is strictly prohibited.
- This product is intended to be handled by skilled/trained personnel for electric devices.
- This product is UL Recognized Component. In order to comply with UL standards, end-products are necessary to be designed by those who have knowledge of the requirements.



- Power Supply**
Ensure that the instrument's supply voltage matches the voltage of the power supply before turning ON the power.
- Do Not Use in an Explosive Atmosphere**
Do not operate the instrument in locations with combustible or explosive gases or steam. Operation in such environments constitutes an extreme safety hazard. Use of the instrument in environments with high concentrations of corrosive gas (H₂S, SO_x, etc.) for extended periods of time may cause a failure.
- Do Not Remove Internal Unit**
The internal unit should not be removed by anyone other than YOKOGAWA's service personnel. There are dangerous high voltage parts inside. Additionally, do not replace the fuse by yourself.
- Damage to the Protective Construction**
Operation of the instrument in a manner not specified in the operation guide may damage its protective construction.



CAUTION
This instrument is an EMC class A product. In a domestic environment this product may cause radio interference in which case the user needs to take adequate measures.

2. Model and Suffix Codes

UT35A «Standard Code Model»

| Model | Suffix code | Option code | Description |
|-----------------------|-------------|-------------|---|
| UT35A | | | Digital Indicating Controller (Power supply: 100-240 V AC) (provided with retransmission output or 15 V DC loop power supply, 2 DIs, and 3 DOs) |
| Type 1: Basic control | -0 | | Standard type |
| | -1 | | Position proportional type |
| | -2 | | Heating/cooling type |
| Type 2: Functions | 0 | | None |
| | 1 | | 2 additional DIs, 2 additional DOs |
| | 2 | | 5 additional DIs, 5 additional DOs |
| Type 3: Open networks | 0 | | None |
| | 1 | | RS-485 communication (Max. 38.4 kbps, 2-wire/4-wire) |
| | 2 | | Ethernet communication (with serial gateway function) |
| | 3 | | CC-Link communication (with Modbus master function) |
| | 4 | | PROFIBUS-DP communication (with Modbus master function) |
| Display language (*1) | -1 | | English (Default. Can be switched to other language by the setting.) |
| | -2 | | German (Default. Can be switched to other language by the setting.) |
| | -3 | | French (Default. Can be switched to other language by the setting.) |
| | -4 | | Spanish (Default. Can be switched to other language by the setting.) |
| Case color | 0 | | White (Light gray) |
| | 1 | | Black (Light charcoal gray) |
| Fixed code | | -00 | Always "-00" (for Standard Code Model) |
| Option codes | /LP | | 24 V DC loop power supply (*2) |
| | /HA | | Heater break alarm (*3) |
| | /DC | | Power supply 24 V AC/DC |
| | /CT | | Coating (*4) |
| | /CV | | Terminal cover |
| | /MDL | | Mount on DIN rail (without the display parts and keys) (please see the Operation Guide IM 05P01D81-11EN.) |
| | /RSP | | Non-isolated remote input (please see the Operation Guide IM 05P01D31-81EN.) |

- English, German, French, and Spanish are available for the guide display.
- The /LP option can be specified in the combination of Type 2 code (any of "0" or "1") and Type 3 code (any of "0" or "1").
- The /HA option can be specified only when the Type 1 code is "-0" or "-2."
- When the /CT option is specified, the UT35A does not conform to the safety standards (UL and CSA) and CE marking (Products with /CT option are not intended for EEA-market).

UT32A «Standard Code Model»

| Model | Suffix code | Option code | Description |
|-----------------------|-------------|--|--|
| UT32A | | | Digital Indicating Controller (Power supply: 100-240 V AC) (provided with retransmission output or 15 V DC loop power supply, 2 DIs, and 3 DOs) |
| Type 1: Basic control | -0 | | Standard type |
| | -1 | | Position proportional type |
| | -2 | | Heating/cooling type |
| | -D | | Dual-loop type (please see the Operation Guide IM 05P08D31-11EN.) |
| | -V | | UT32A Digital Indicating Controller (Entry model) (please see the Operation Guide IM 05P01F31-11EN.) |
| | -C | | |
| Type 2: Functions | 0 | | None |
| | 1 | | RS-485 communication (Max. 38.4 kbps, 2-wire/4-wire) (*1) |
| Type 3: Open networks | 0 | | None |
| | 3 | | CC-Link communication (with Modbus master function) (*2) |
| Display language (*3) | -1 | | English (Default. Can be switched to other language by the setting.) |
| | -2 | | German (Default. Can be switched to other language by the setting.) |
| | -3 | | French (Default. Can be switched to other language by the setting.) |
| | -4 | | Spanish (Default. Can be switched to other language by the setting.) |
| Case color | 0 | | White (Light gray) |
| | 1 | | Black (Light charcoal gray) |
| Fixed code | | -00 | Always "-00" (for Standard Code Model) |
| Option codes | /LP | | 24 V DC loop power supply (*4) |
| | /HA | | Heater break alarm (*5) |
| | /DC | | Power supply 24 V AC/DC |
| | /CT | | Coating (*6) |
| | /CV | | Terminal cover |
| | /MDL | | Mount on DIN rail (without the display parts and keys) (In case of the Standard type, the Position proportional type, or the Heating/cooling type, please see the Operation Guide IM 05P01D81-11EN. In case of the Dual-loop type, please see the Operation Guide IM 05P08D81-11EN.) |
| /RSP | | Non-isolated remote input (please see the Operation Guide IM 05P01D31-81EN.) | |

- When the /LP option is specified, the RS-485 communication of the Type 2 code "1" is 2-wire system.
- The type 3 code "3" can be specified only when the Type 1 code is "-0" and the Type 2 code is "0."
- English, German, French, and Spanish are available for the guide display.
- The /LP option can be specified in the combination of Type 1 code (any of "0" or "1"), Type 2 code (any of "0" or "1") and Type 3 code "0."
- The /HA option can be specified in the combination of Type1 code "-0" or "-2," and Type 3 code "0."
- When the /CT option is specified, the UT32A does not conform to the safety standards (UL and CSA) and CE marking (Products with /CT option are not intended for EEA-market).

Accessories (sold separately)

The following is an accessory sold separately.

- LL50A Parameter Setting Software

| Model | Suffix code | Description |
|-------|-------------|----------------------------|
| LL50A | -00 | Parameter Setting Software |

- External Precision Resistor

| Model | Suffix code | Description |
|-------|-------------|--|
| X010 | | See the General Specifications (*) Resistance Module |

- *: Necessary to input the current signal to the voltage input terminal.
- Terminal Cover
For UT35A: Model UTAP001; For UT32A: Model UTAP002
- Manuals

Note: Manuals can be downloaded from a website. URL: <http://www.yokogawa.com/ns/ut/im/>

- Brackets
Part number: L4502TP (2 pcs for upper and lower sides)

3. How to Install

Installation Location

The instrument should be installed in indoor locations meeting the following conditions:

- Instrumented panel**
This instrument is designed to be mounted in an instrumented panel. Mount the instrument in a location where its terminals will not inadvertently be touched.
- Well ventilated locations**
Mount the instrument in well ventilated locations to prevent the instrument's internal temperature from rising. However, make sure that the terminal portions are not exposed to wind. Exposure to wind may cause the temperature sensor accuracy to deteriorate. To mount multiple indicating controllers, see the external dimensions/panel cutout dimensions which follow. If mounting other instruments adjacent to the instrument, comply with these panel cutout dimensions to provide sufficient clearance between the instruments.
- Locations with little mechanical vibration**
Install the instrument in a location subject to little mechanical vibration.
- Horizontal location**
Mount the instrument horizontally and ensure that it is level, with no inclination to the right or left.

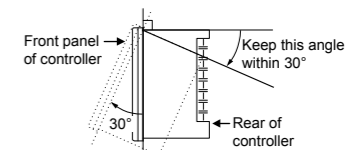

Note

If the instrument is moved from a location with low temperature and low humidity to a place with high temperature and high humidity, or if the temperature changes rapidly, condensation will result. Moreover, in the case of thermocouple inputs, measurement errors will result. To avoid such a situation, leave the instrument in the new environment under ambient conditions for more than 1 hour prior to using it.

Do not mount the instrument in the following locations:

- Outdoors**
- Locations subject to direct sunlight or close to a heater**
Install the instrument in a location with stable temperatures that remain close to an average temperature of 23°C. Do not mount it in locations subject to direct sunlight or close to a heater. Doing so adversely affects the instrument.
- Locations with substantial amounts of oily fumes, steam, moisture, dust, or corrosive gases**
The presence of oily fumes, steam, moisture, dust, or corrosive gases adversely affects the instrument. Do not mount the instrument in locations subject to any of these substances.
- Areas near electromagnetic field generating sources**
Do not place magnets or tools that generate magnetism near the instrument. If the instrument is used in locations close to a strong electromagnetic field generating source, the magnetic field may cause measurement errors.
- Locations where the display is difficult to see**
The instrument uses an LCD for the display unit, and this can be difficult to see from extremely oblique angles. Mount the instrument in a location where it can be seen as much as possible from the front.
- Areas close to flammable articles**
Absolutely do not place the instrument directly on flammable surfaces. If such a circumstance is unavoidable and the instrument must be placed close to a flammable item, provide a shield for it made of 1.43 mm thick plated steel or 1.6 mm thick unplated steel with a space of at least 150 mm between it and the instrument on the top, bottom, and sides.
- Areas subject to being splashed with water**

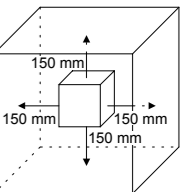

WARNING
Be sure to turn OFF the power supply to the controller before installing it on the panel to avoid an electric shock.

YOKOGAWA

YOKOGAWA ELECTRIC CORPORATION
Network Solutions Business Division
2-9-32, Naka-cho Musashino-shi, Tokyo 180-8750 JAPAN
YOKOGAWA CORPORATION OF AMERICA
Head office and for product sales
2 Dart Road, Newnan, Georgia 30265, USA
YOKOGAWA EUROPE B.V.
Headquarters

Euroweg 2, 3825 HD Amersfoort, THE NETHERLANDS

www.yokogawa.com/ns

■ Mounting the Instrument Main Unit

Provide an instrumented panel steel sheet of 1 to 10 mm thickness. After opening the mounting hole on the panel, follow the procedures below to install the controller:

- 1) Insert the controller into the opening from the front of the panel so that the terminal board on the rear is at the far side.
- 2) Set the brackets in place on the top and bottom of the controller as shown in the figure below, then tighten the screws of the brackets. Take care not to overtighten them.

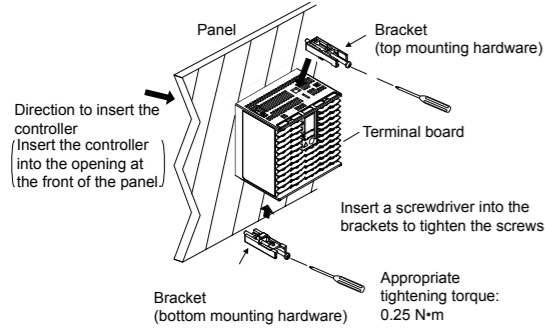

- Tighten the screws with appropriate tightening torque within 0.25 N·m. Otherwise it may cause the case deformation or the bracket damage.
- Make sure that foreign materials do not enter the inside of the instrument through the case's slit holes.

■ External Dimensions and Panel Cutout Dimensions

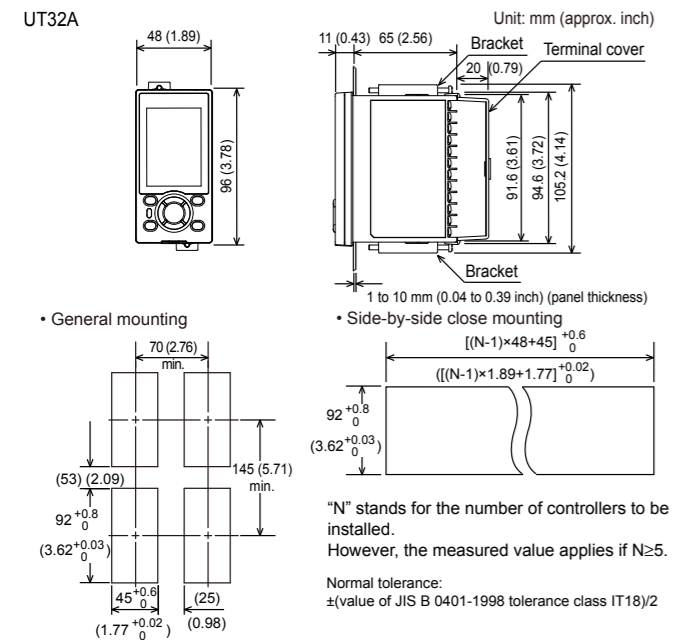
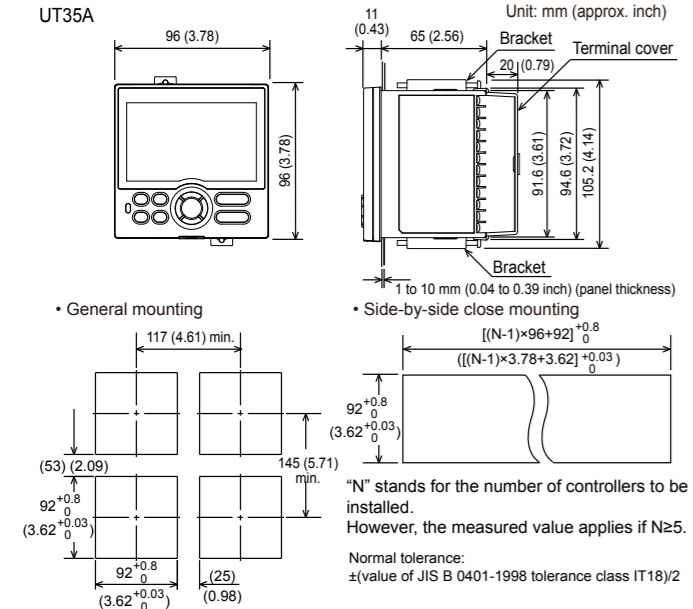

4. Hardware Specifications



This instrument is for Measurement Category No.1. Do not use it for measurements in locations falling under Measurement Categories No.2, No.3, and No.4.

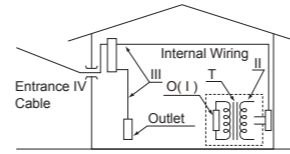

| Category | IEC/EN/CSA/UL 61010-1 | EN 61010-2-030 | Remarks |
|----------|--------------------------|--------------------------|--|
| No.1 | Measurement Category I | O (Other) | For measurements performed on circuits not directly connected to MAINS. |
| No.2 | Measurement Category II | Measurement Category II | For measurements performed on circuits directly connected to the low-voltage installation. |
| No.3 | Measurement Category III | Measurement Category III | For measurements performed in the building installation. |
| No.4 | Measurement Category IV | Measurement Category IV | For measurements performed at the source of the low-voltage installation. |

■ Input Specifications

● Universal Input (Equipped as standard)

- Number of inputs: 1
- Input type, instrument range, and measurement accuracy: See the table below,

| Input Type | Instrument Range | | Accuracy | |
|--------------------|---------------------|--------------------|------------------------------------|--|
| | °C | °F | | |
| Thermocouple | K | -270.0 to 1370.0°C | -450.0 to 2500.0°F | ±0.1% of instrument range ±1 digit for 0°C or more |
| | | -270.0 to 1000.0°C | -450.0 to 2300.0°F | ±0.2% of instrument range ±1 digit for less than 0°C |
| | | -200.0 to 500.0°C | -200.0 to 1000.0°F | ±2% of instrument range ±1 digit for less than 0°C |
| | J | -200.0 to 1200.0°C | -300.0 to 2300.0°F | ±2% of instrument range ±1 digit for less than 0°C |
| | | -270.0 to 400.0°C | -450.0 to 750.0°F | ±1% of instrument range ±1 digit for less than -200.0°C of thermocouple K |
| | T | 0.0 to 400.0°C | -200.0 to 750.0°F | ±1.5% of instrument range ±1 digit for less than -200.0°C of thermocouple T |
| | | 0.0 to 1800.0°C | 32 to 3300°F | ±0.15% of instrument range ±1 digit for 400°C or more |
| | S | 0.0 to 1700.0°C | 32 to 3100°F | ±5% of instrument range ±1 digit for less than 400°C |
| | R | 0.0 to 1700.0°C | 32 to 3100°F | ±0.15% of instrument range ±1 digit |
| | RTD | N | -200.0 to 1300.0°C | -300.0 to 2400.0°F |
| -270.0 to 1000.0°C | | | -450.0 to 1800.0°F | ±0.1% of instrument range ±1 digit for 0°C or more |
| L | | -200.0 to 900.0°C | -300.0 to 1600.0°F | ±0.2% of instrument range ±1 digit for less than 0°C |
| | | -200.0 to 400.0°C | -300.0 to 750.0°F | ±1.5% of instrument range ±1 digit for less than -200.0°C of thermocouple E. |
| U | | 0.0 to 400.0°C | -200.0 to 1000.0°F | ±0.2% of instrument range ±1 digit (Note 2) |
| | | 0.0 to 2300.0°C | 32 to 4200°F | ±0.1% of instrument range ±1 digit |
| Platinel 2 | | 0.0 to 1390.0°C | 32.0 to 2500.0°F | ±0.5% of instrument range ±1 digit for 800°C or more |
| PR20-40 | | 0.0 to 1900.0°C | 32 to 3400°F | Accuracy is not guaranteed for less than 800°C. |
| W97Re3-W75Re25 | | 0.0 to 2000.0°C | 32 to 3600°F | ±0.2% of instrument range ±1 digit |
| | | JPt100 | -200.0 to 500.0°C | -300.0 to 1000.0°F |
| Pt100 | -150.00 to 150.00°C | | -200.0 to 300.0°F | ±0.1% of instrument range ±1 digit |
| | Standard signal | 0.400 to 2.000 V | | ±0.1% of instrument range ±1 digit |
| DC voltage/current | | 1.000 to 5.000 V | | ±0.1% of instrument range ±1 digit |
| | 4.00 to 20.00 mA | | ±0.1% of instrument range ±1 digit | |
| | 0.000 to 2.000 V | | ±0.1% of instrument range ±1 digit | |
| | 0.00 to 10.00 V | | ±0.1% of instrument range ±1 digit | |
| | 0.00 to 20.00 mA | | ±0.1% of instrument range ±1 digit | |
| | -10.00 to 20.00 mV | | ±0.1% of instrument range ±1 digit | |
| | 0.0 to 100.0 mV | | ±0.1% of instrument range ±1 digit | |

The accuracy is that in the standard operating conditions: 23±2°C, 55±10%RH, and power frequency at 50/60 Hz.

Note 1: ±0.3°C ±1 digit in the range between 0 and 100°C, ±0.5°C ±1 digit in the range between -100 and 200°C.

Note 2: W: W-5% Re/W-26% Re(Hoskins Mfg.Co.), ASTM E988

- Input sampling (control) period: 200 ms
- Burnout detection:
 - Functions at TC, RTD, and standard signal. Upscale, downscale, and off can be specified.
 - For standard signal, burnout is determined to have occurred if it is 0.1 V or 0.4 mA or less.
- Input bias current: 0.05 µA (for TC or RTD)
- Measured current (RTD): About 0.16 mA
- Input resistance:
 - TC or mV input: 1 MΩ or more
 - V input: About 1 MΩ
 - mA input: About 250 Ω

- Allowable signal source resistance:
 - TC or mV input: 250 Ω or less
 - Effects of signal source resistance: 0.1 µV/Ω or less
 - DC voltage input: 2 kΩ or less
 - Effects of signal source resistance: About 0.01%/100 Ω
- Allowable wiring resistance:
 - RTD input: Max. 150 Ω/wire (The conductor resistance between the three wires shall be equal.)
 - Wiring resistance effect: ±0.1°C/10 Ω
- Allowable input voltage/current:
 - TC, mV, mA and RTD input: ±10 V DC
 - V input: ±20 V DC
 - mA input: ±40 mA
- Noise rejection ratio:
 - Normal mode: 40 dB or more (at 50/60 Hz)
 - Common mode: 120 dB or more (at 50/60 Hz)
 - For 100-240 V AC, the power frequency can be set manually. Automatic detection is also available.
 - For 24 V AC/DC, the power frequency can be set manually.
- Reference junction compensation error: ±1.0°C (15 to 35°C), ±1.5°C (-10 to 15°C and 35 to 50°C)
- Applicable standards: JIS/IEC/DIN (ITS-90) for TC and RTD

■ Contact Input Specifications

- Number of inputs: See the table of Model and Suffix Codes.
- Input type: No-voltage contact input or transistor contact input
- Input contact rating: 12 V DC, 10 mA or more
- Use a contact with a minimum on-current of 1 mA or less.
- ON/OFF detection:
 - No-voltage contact input:
 - Contact resistance of 1 kΩ or less is determined as "ON" and contact resistance of 50 kΩ or more as "OFF."
 - Transistor contact input:
 - Input voltage of 2 V or less is determined as "ON" and leakage current must not exceed 100 µA when "OFF."
- Minimum status detection hold time: Control period +50 ms
- Use: SP switch, operation mode switch, and event input

■ Analog Output Specifications

- Number of outputs:
 - Control output: 1
 - Cooling-side control output of Heating/cooling type (Retransmission output terminal): 1
- Output type: Current output or voltage pulse output
- Current output: 4 to 20 mA DC or 0 to 20 mA DC/load resistance of 600 Ω or less
- Current output accuracy (conversion accuracy from PV display on the set scale): ±0.1% of span (±5% of span for 1 mA or less)
- The accuracy is that in the standard operating conditions: 23±2°C, 55±10%RH, and power frequency at 50/60 Hz.
- Voltage pulse output:
 - Use: Time proportional output
 - On-voltage: 12 V or more/load resistance of 600 Ω or more
 - Off-voltage: 0.1 V DC or less
 - Time resolution: 10 ms or 0.1% of output, whichever is larger

■ Retransmission Output Specifications

- Number of outputs: Retransmission output; 1, shared with 15 V DC loop power supply or Cooling-side control output.
- Current output: 4 to 20 mA DC or 0 to 20 mA DC/ load resistance of 600 Ω or less
- Current output accuracy (conversion accuracy from PV display on the set scale): ±0.1% of span (±5% of span for 1 mA or less)
- The accuracy is that in the standard operating conditions: 23±2°C, 55±10%RH, and power frequency at 50/60 Hz.
- This is not conversion accuracy through input and output but the performance of transmission output itself.

■ 15 V DC Loop Power Supply Specifications

- (Shared with retransmission output or Cooling-side control output.)
- Power supply: 14.5 to 18.0 V DC
- Maximum supply current: About 21 mA (with short-circuit current limiting circuit)

■ Step Response Time Specifications

Within 1 s (63% of analog output response time when a step change of 10 to 90% of input span is applied)

■ Relay Contact Output Specifications

- Contact type and number of outputs:
 - Control output: contact point 1c; 1 point
 - Heating/cooling type: contact point 1a; 2 points for both heating and cooling sides
 - Alarm output: contact point 1a; 3 points (common is independent)
- Contact rating:
 - Contact point 1c (control output): 250 V AC, 3 A or 30 V DC, 3 A (resistance load)
 - Contact point 1a (control output): 240 V AC, 3 A or 30 V DC, 3 A (resistance load)
 - Contact point 1a (alarm output): 240 V AC, 1 A or 30 V DC, 1 A (resistance load)
- Use: Time proportional output, alarm output, FAIL output, etc.
- Time resolution of control output: 10 ms or 0.1% of output, whichever is larger

Note: The control output should always be used with a load of 10 mA or more. The alarm output should always be used with a load of 1 mA or more.

■ Transistor Contact Output Specifications

- Number of outputs: See the table of Model and Suffix Codes.
- Output type: Open collector (SINK current)
- Output contact rating: Max. 24 V DC, 50 mA
- Output time resolution: Min. 200 ms
- Use: Alarm output, FAIL output, etc.

■ Position Proportional Output Specifications

- Position signal input:
 - Slide resistance: 100 Ω to 2.5 kΩ of total resistance
 - 100% side and slide line: with disconnection detection
 - 0% side: without disconnection detection
 - Current input: 4 to 20 mA (with disconnection detection)
 - Sampling period: 50 ms
 - Measurement resolution: 0.1% of input span
 - Position proportional relay output:
 - UT35A: contact point 1a; 2 points, 250 V AC, 3 A or 30 V DC, 3 A (resistance load)
 - UT32A: contact point 1a; 2 points, 240 V AC, 3 A or 30 V DC, 3 A (resistance load)
- Note: This should always be used with a load of 10 mA or more.

■ Heater Break Alarm Specifications

- Number of inputs: 2
- Number of outputs: 2 (transistor contact output)
- Use: Measures the heater current using an external current transformer (CT) and generates a heater break alarm when the measured value is less than the break detection value.
- Current transformer input resistance: About 9.4 Ω
- Current transformer input range: 0.0 to 0.1 Arms (0.12 Arms or more cannot be applied.)
- Heater current setting range: OFF, 0.1 to 300.0 Arms
- Heater current measured value display range: 0.0 to 360.0 Arms
- Note: The CT ratio can be set. CT ratio setting range: 1 to 3300
- Recommended CT: CT from U.R.D., Ltd.
 - CTL-6-S-H: CT ratio 800, measurable current range: 0.1 to 80.0 Arms
 - CTL-12L-30: CT ratio 3000, measurable current range: 0.1 to 180.0 Arms
- Heater current measurement period: 200 ms
- Heater current measurement accuracy: ±5% of current transformer input range span ± 1digit (CT error is not included.)
- Heater current detection resolution: Within 1/250 of current transformer input range span
- Break detection On-time: Min. 0.2 second (for time proportional output)

■ 24 V DC Loop Power Supply Specifications

- Use: Power is supplied to a 2-wire transmitter.
- Power supply: 21.6 to 28.0 V DC
- Rated current: 4 to 20 mA DC
- Maximum supply current: About 30 mA (with short-circuit current limiting circuit.)

■ Safety and EMC Standards

- Safety:
 - Compliant with IEC/EN 61010-1 (CE), IEC/EN 61010-2-201 (CE), IEC/EN 61010-2-030 (CE), approved by CAN/CSA C22.2 No. 61010-1 (CSA), approved by UL 61010-1.
 - Installation category: II
 - Pollution degree: 2
 - Measurement category: I (CAT I) (UL, CSA) O (Other) (CE)
 - Rated measurement input voltage: Max. 10 V DC
 - Rated transient overvoltage: 1500 V (*)
 - * This is a reference safety standard value for measurement category I of CSA/UL 61010-1, and for measurement category O of IEC/EN 61010-2-030. This value is not necessarily a guarantee of instrument performance.
- EMC standards:
 - Compliant with CE marking
 - EN 61326-1 Class A, Table 2 (For use in industrial locations), EN 61326-2-3
 - * The instrument continues to operate at a measurement accuracy of within ±20% of the range during testing.
 - EN 55011 Class A, Group 1
 - EN 61000-3-2 Class A
 - EN 61000-3-3
 - EMC Regulatory Arrangement in Australia and New Zealand (for all model including LL50A)
 - EN 55011 Class A, Group 1
- KC marking:
 - Electromagnetic wave interference prevention standard, electromagnetic wave protection standard compliance

■ Construction, Installation, and Wiring

- Dust-proof and drip-proof: IP66 (for front panel) (Not available for side-by-side close mounting.)
- Material: Polycarbonate (Flame retardancy: UL94V-0)
- Case color: White (Light gray) or Black (Light charcoal gray)
- Weight: 0.5 kg or less
- External dimensions (mm):
 - UT35A: 96 (W) × 96 (H) × 65 (depth from the panel face)
 - UT32A: 48 (W) × 96 (H) × 65 (depth from the panel face)
 - (Depth except the projection on the rear panel)

- Installation: Direct panel mounting; mounting bracket, one each for upper and lower mounting
- Panel cutout dimensions (mm):
 UT35A: $92^{+0.80}$ (W) \times $92^{+0.80}$ (H)
 UT32A: $45^{+0.80}$ (W) \times $92^{+0.80}$ (H)
- Mounting attitude: Up to 30 degrees above the horizontal. No downward tilting allowed.
- Wiring: M3 screw terminal with square washer (for signal wiring and power wiring)

■ Power Supply Specifications and Isolation

- Power supply:
 Rated voltage: 100-240 V AC (+10%/-15%), 50/60 Hz
 24 V AC/DC (+10%/-15%) (for /DC option)
- Power consumption: UT35A: 18 VA (DC:9 VA, AC: 14 VA if /DC option is specified)
 UT32A: 15 VA (DC:7 VA, AC: 11 VA if /DC option is specified)
- Data backup: Nonvolatile memory
- Power holdup time: 20 ms (for 100 V AC drive)
- Withstanding voltage
 Between primary terminals and secondary terminals: 2300 V AC for 1 minute (UL, CSA)
 Between primary terminals and secondary terminals: 3000 V AC for 1 minute (CE)
 Between primary terminals: 1500 V AC for 1 minute
 Between secondary terminals: 500 V AC for 1 minute
 (Primary terminals: Power* and relay output terminals; Secondary terminals: Analog I/O signal terminals, contact input terminals, communication terminals and functional grounding terminals.)
- *: Power terminals for 24V AC/DC models are the secondary terminals.
- Insulation resistance: Between power supply terminals and a grounding terminal 20 MΩ or more at 500 V DC
- Isolation specifications

| PV (universal) input terminals | Internal circuits | Power supply |
|--|----------------------|-----------------|
| Control, retransmission (analog) output terminals (not isolated between the analog output terminals) Valve position (feedback) input terminals | | |
| Control relay (contact point c/contact point a x2) output terminals | | |
| Alarm-1 relay (contact point a) output terminals | | |
| Alarm-2 relay (contact point a) output terminals | | |
| Alarm-3 relay (contact point a) output terminals | | |
| Position proportional relay output terminals | | |
| Contact input terminals (all) RS-485 communication terminals (2 ports) | | |
| 24 V DC loop power supply terminals | | |
| Contact output (transistor) terminals | | |
| Ethernet communication terminal | | |
| PROFIBUS-DP/DeviceNet/CC-Link communication terminals | | |
| Current transformer input terminals | | |

The circuits divided by lines are insulated mutually.

■ Environmental Conditions

Normal Operating Conditions:

- Ambient temperature: -10 to 50 °C (side-by-side mounting: -10 to 40 °C)
 If the CC-Link option is specified, 0 to 50 °C for UT35A; 0 to 40 °C for UT32A. (side-by-side mounting: 0 to 40 °C for UT35A and UT32A with CC-Link option)
- Ambient humidity: 20 to 90% RH (no condensation allowed)
- Magnetic field: 400 A/m or less
- Continuous vibration at 5 to 9 Hz: Half amplitude of 1.5 mm or less, 1oct/min for 90 minutes each in the three axis directions
 Continuous vibration at 9 to 150 Hz: 4.9 m/s² or less, 1oct/min for 90 minutes each in the three axis directions
- Short-period vibration: 14.7 m/s², 15 seconds or less
- Shock: 98 m/s² or less, 11 ms
- Altitude: 2000 m or less above sea level
- Warm-up time: 30 minutes or more after the power is turned on
- Startup time: Within 10 seconds
- *: The LCD (a liquid crystal display) is used for a display portion of this product. The LCD has a characteristic that the display action becomes late at the low temperature. However, the control function is not affected.

Transportation and Storage Conditions:

- Temperature: -25 to 70 °C
- Temperature change rate: 20 °C/h or less
- Humidity: 5 to 95% RH (no condensation allowed)

Effects of Operating Conditions

- Effect of ambient temperature:
 Voltage or TC input: $\pm 1 \mu\text{V}/^\circ\text{C}$ or $\pm 0.01\%$ of F.S./°C, whichever is larger
 Current input: $\pm 0.01\%$ of F.S./°C
 RTD input: $\pm 0.05^\circ\text{C}/^\circ\text{C}$ (ambient temperature) or less
 Analog output: $\pm 0.02\%$ of F.S./°C or less
- Effect of power supply voltage fluctuation
 Analog input: $\pm 0.05\%$ of F.S. or less
 Analog output: $\pm 0.05\%$ of F.S. or less
 (Each within rated voltage range)

5. How to Connect Wires



- Wiring work must be carried out by a person with basic electrical knowledge and practical experience.
- Be sure to turn OFF the power supply to the controller before wiring to avoid an electric shock. Use a tester or similar device to ensure that no power is being supplied to a cable to be connected.
- For the wiring cable, the temperature rating is 75 °C or more.
- As a safety measure, always install a circuit breaker (an IEC 60947-compatible product, 5 A, 100 V or 220 V AC) in an easily accessible location near the instrument. Moreover, provide indication that the switch is a device for turning off the power to the instrument.
- Install the power cable keeping a distance of more than 1 cm from other signal wires.
- The power cable is required to meet the IEC standards concerned or the requirements of the area in which the instrument is being installed.
- Wiring should be installed to conform to NEC (National Electrical Code: ANSI/NFPA-70) or the wiring construction standards in countries or regions where wiring will be installed.
- Since the insulation provided to each relay output terminal is Functional insulation, provide Reinforced insulation to the external of the device as necessary. (Refer to the drawing below.)

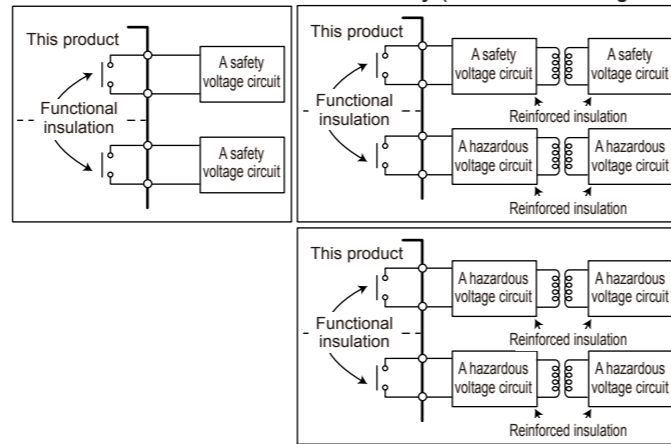

- When connecting two or more crimp-on terminal lugs to the single terminal block, bend the crimp-on terminal lugs before tightening the screw.
- Note that the wiring of two or more crimp-on terminal lugs to the single high-voltage terminal of the power supply and relay, etc. does not comply with the safety standard.



- Provide electricity from a single-phase power supply. If the power is noisy, install an isolation transformer on the primary side, and use a line filter on the secondary side. When measures against noise are taken, do not install the primary and secondary power cables close to each other.
- If there is a risk of external lightning surges, use a lightning arrester etc.
- For TC input, use shielded compensating lead wires for wiring. For RTD input, use shielded wires that have low conductor resistance and cause no significant differences in resistance between the three wires.
- Since the control output relay has a life span (resistance load of 100,000 times), use the auxiliary relay to perform ON/OFF control.
- The use of inductance (L) loads such as auxiliary relays, motors and solenoid valves causes malfunction or relay failure; always insert a CR filter for use with alternating current or a diode for use with direct current, as a spark-removal surge suppression circuit, into the line in parallel with the load.
- After completing the wiring, the terminal cover is recommended to use for the instrument.

• Recommended Crimp-on Terminal Lugs

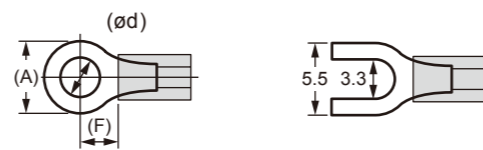

Recommended tightening torque: 0.6 N·m
 Applicable wire size: Power supply wiring 1.25 mm² or more

| Applicable terminal lug | Applicable wire size mm ² (AWG#) | (ø d) | (A) | (F) |
|-------------------------|---|-------|-----|-----|
| M3 | 0.25 to 1.65 (22 to 16) | 3.3 | 5.5 | 4.2 |

• Cable Specifications and Recommended Cables

| Purpose | Name and Manufacturer |
|---|---|
| Power supply, relay contact outputs | 600 V Grade heat-resistant PVC insulated wires, JIS C 3317(HIV), 0.9 to 2.0 mm ² |
| Thermocouple | Shielded compensating lead wires, JIS C 1610 For thermocouple input (PV input and remote input with direct input), shielded compensating lead wire of cross-sectional area less than or equal to 0.75 mm ² is recommended. If the cross-sectional area is wide, the reference junction compensation error may be large. |
| RTD | Shielded wires (three/four conductors), UL2482 (Hitachi Cable) |
| Other signals (other than contact input/output) | Shielded wires |
| Other signals (contact input/output) | Unshielded wires |
| RS-485 communication | Shielded wires |
| Ethernet communication | 100 BASE-TX (CAT-5)/10 BASE-T |
| PROFIBUS-DP communication | Dedicated cable for PROFIBUS-DP (Shielded two-wires) |
| DeviceNet communication | Dedicated cable for DeviceNet (Shielded five-wires) |
| CC-Link communication | Dedicated cable for CC-Link (Shielded three-wires) |

PROFIBUS-DP/CC-Link Connector (wiring side) (Part number: A1987JT)

DeviceNet Connector (wiring side) (Part number: L4502BW)

Recommended tightening torque: 0.5 to 0.6 N·m

6. Terminal Wiring Diagrams



- Do not use an unassigned terminal as the relay terminal.
- Do not use a 100-240 V AC power supply for the 24 V AC/DC model; otherwise, the instrument will malfunction.

■ UT35A

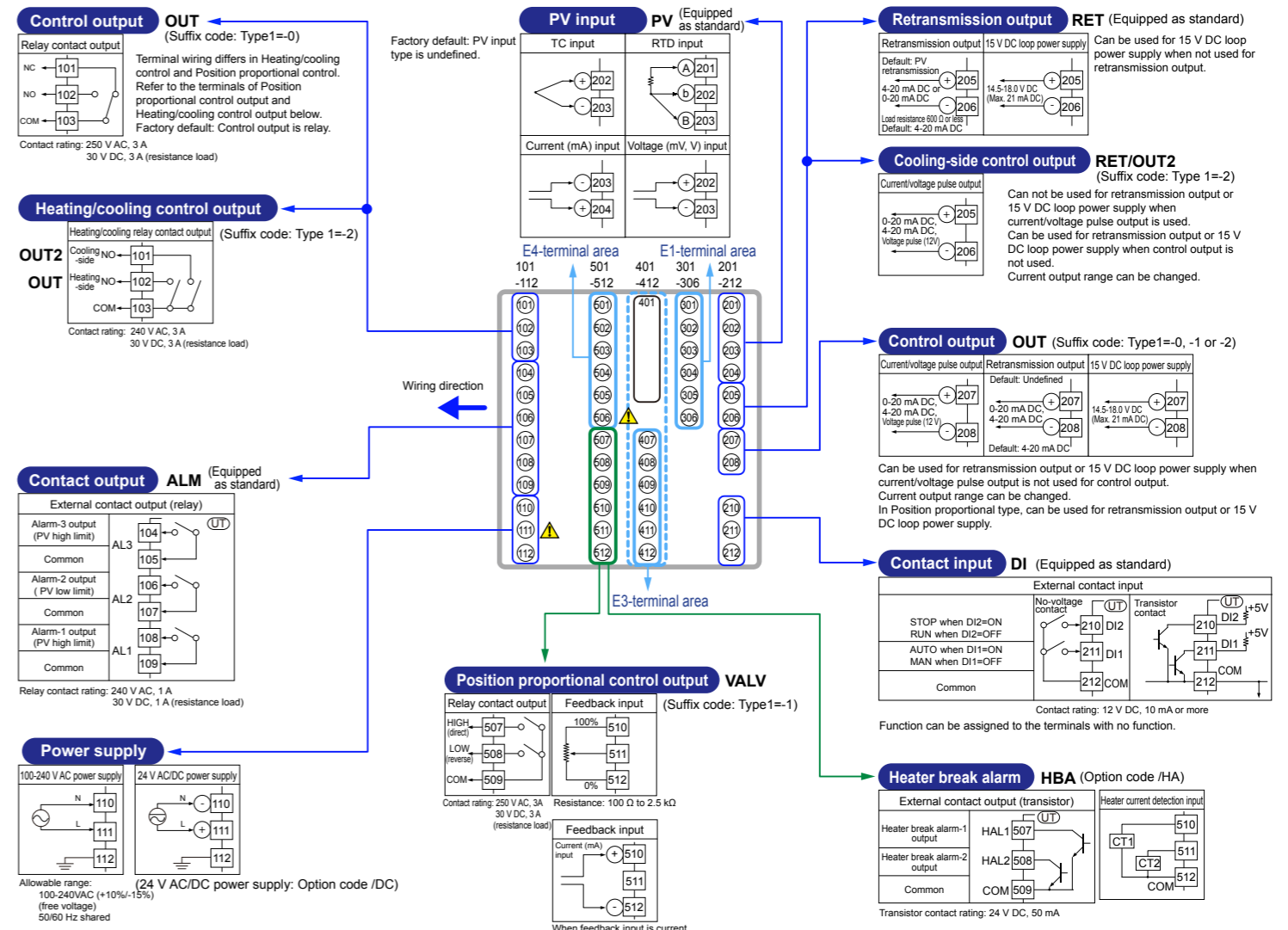

DC Relay Wiring

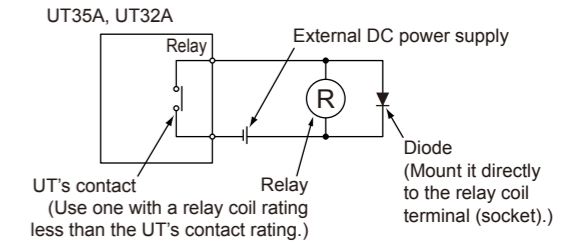

AC Relay Wiring

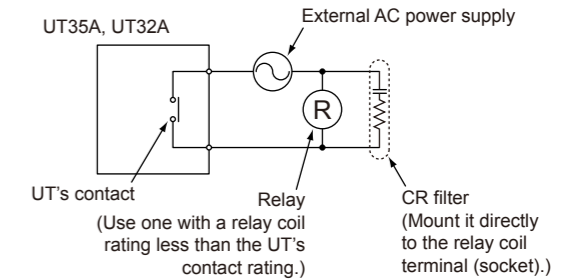

Transistor Output Wiring

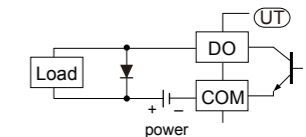

■ UT35A (Continued from page 3)

E4-terminal area E1-terminal area

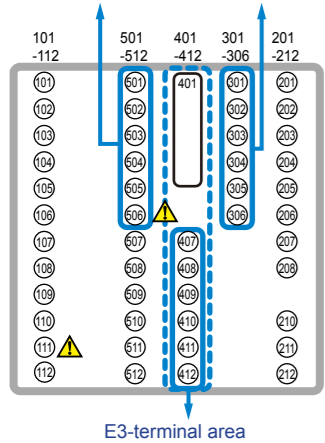

301-306 E1-Terminal Area

Contact input DI (Suffix code: Type 2=2)

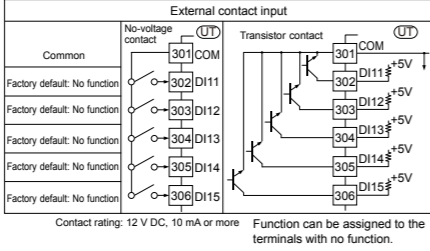

Contact input / Contact output DI/DO (Suffix code: Type 2=1)

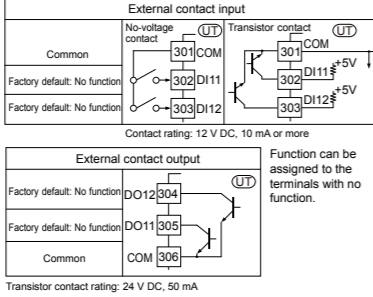

501-506 E4-Terminal Area

Contact output DO (Suffix code: Type 2=2)

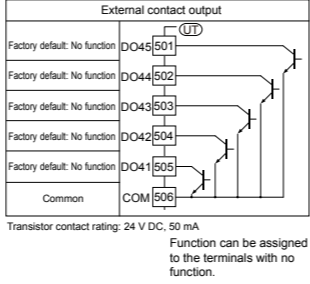

24 V DC loop power supply LPS24 (Option code /LP)

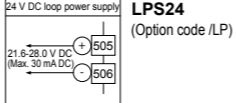

■ UT32A

Control output OUT (Suffix code: Type1=0)

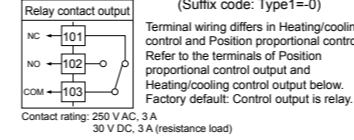

Heating/cooling control output OUT2 (Suffix code: Type 1=-2)

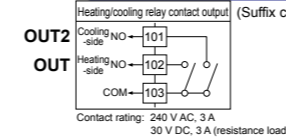

Contact output ALM (Equipped as standard)

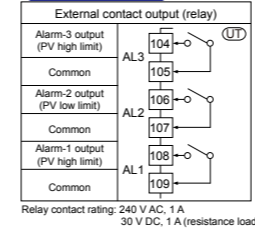

Power supply

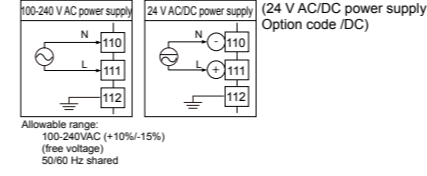

PV input PV (Equipped as standard)

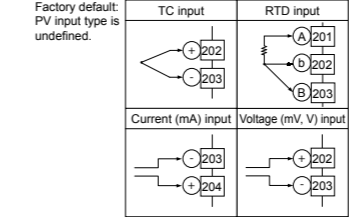

Position proportional control output VALV (Suffix code: Type1=-1)

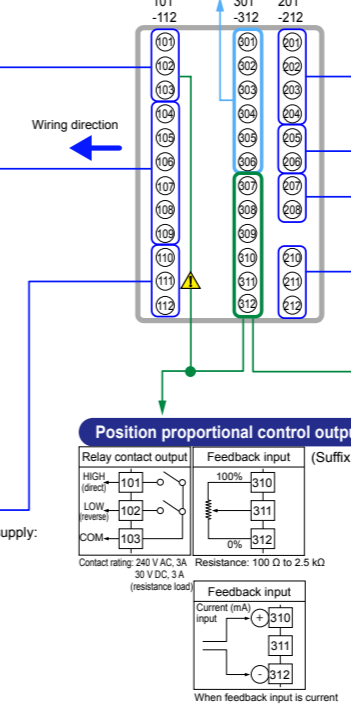

Retransmission output RET (Equipped as standard)

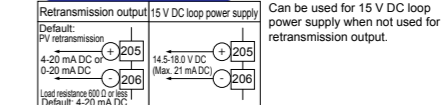

Cooling-side control output RET/OUT2 (Suffix code: Type 1=-2)

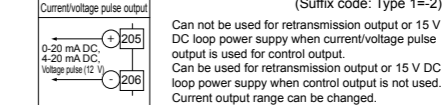

Contact output OUT (Suffix code: Type1=0, -1 or -2)

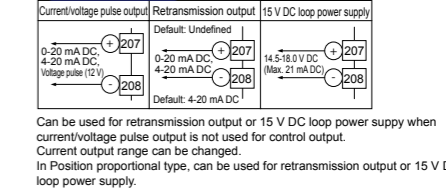

Contact input DI (Equipped as standard)

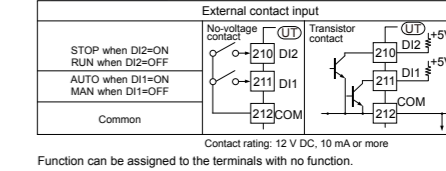

Heater break alarm HBA (Option code /HA)

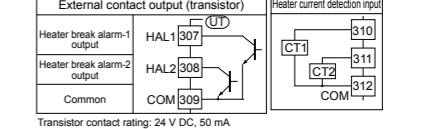

401-412 E3-Terminal Area

RS-485 communication RS485 (Suffix code: Type 3=1)

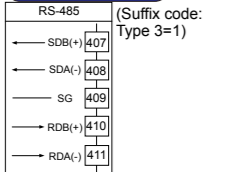

Ethernet communication (with gateway function) ETHR (Suffix code: Type 3=2)

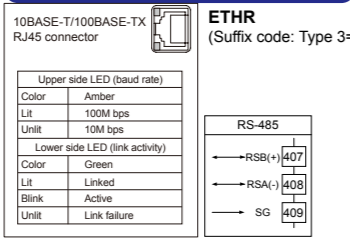

PROFIBUS-DP communication (with Modbus master) PROF (Suffix code: Type 3=4)

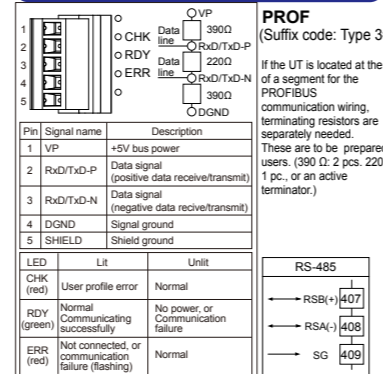

CC-Link communication (with Modbus master) CC-L (Suffix code: Type 3=3)

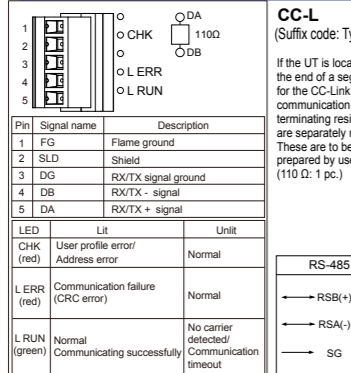

DeviceNet communication (with Modbus master) DNET (Suffix code: Type 3=5, except Type 2=3)

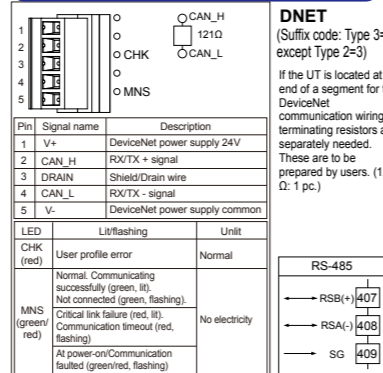

301-306 E1-Terminal Area

RS-485 communication RS485 (Suffix code: Type 2=1)

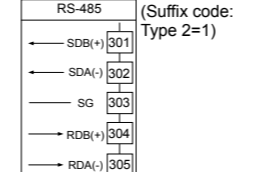

24 V DC loop power supply LPS24 (Suffix code: Type 2=0 and option code /LP)

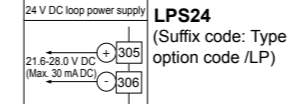

Contact input / Contact output DI/DO (Suffix code: Type 2=2)

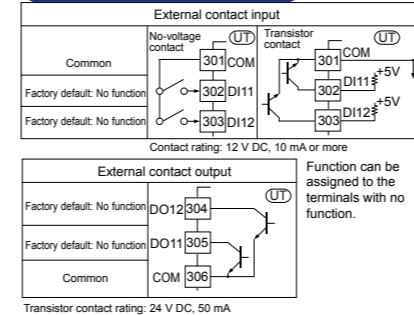

CC-Link communication (with Modbus master) CC-L (Suffix code: Type 3=3)

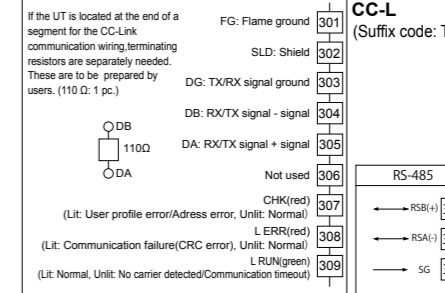

RS-485 communication/24 V DC loop power supply RS485/LPS24 (Suffix code: Type 2=1 and option code /LP)

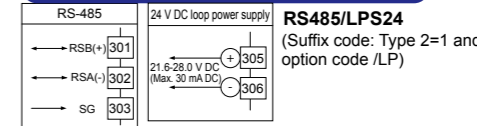

This operation guide describes basic settings and operations of the UT35A and UT32A. For details of each function, see User's manual (IM 05P01D31-01EN). The scrolling guide is displayed on PV display in the Parameter Setting Display. This guide can be turned on/off with the Fn key. For details of the each function, refer to the electronic manual. Manuals can be downloaded or viewed at the following URL.

<http://www.yokogawa.com/ns/ut/im/>

Contents

- Names and Functions of Display Parts
- Setup Procedure
- Quick Setting Function (Setting of Input and Output)
- Adjusting Valve Position Automatically (for a Position Proportional Type Controller Only)
- Setting Alarm Type
- Setting Alarm Setpoint

1. Names and Functions of Display Parts

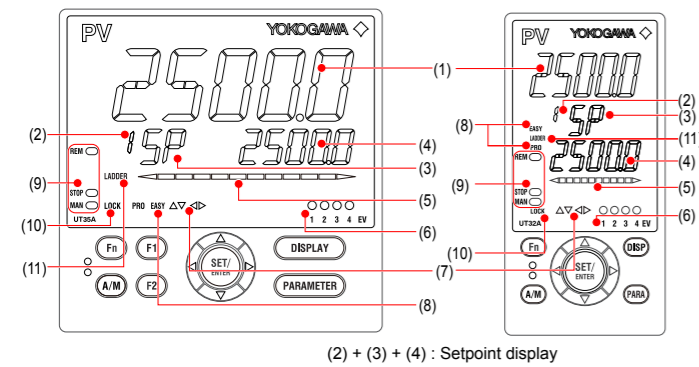

| No. in figure | Name | Description | | | | | | | | | | | | |
|---------------------------|---|---|-------------------------|-------------|-----|--------------------------------|------|-------------------------------|-----------------------|---|-------|---------------------------|-------|-----|
| (1) | PV display (white or red) | Displays PV. Displays an error code if an error occurs. Displays the scrolling guide in the Menu Display and Parameter Setting Display when the guide display ON/OFF is set to ON. | | | | | | | | | | | | |
| (2) | Group display (green) | Displays a group number (1 to 4 or R) and terminal area (E1 to E4). 1 to 4 represent SP numbers in the Operation Display. R and E1 to E4 are displayed in the Parameter Setting Display. | | | | | | | | | | | | |
| (3) | Symbol display (orange) | Displays a parameter symbol. | | | | | | | | | | | | |
| (4) | Data display (orange) | Displays a parameter setpoint and menu symbol. | | | | | | | | | | | | |
| (5) | Bar-graph display (orange) | Displays control output value (OUT) and measured input value (PV). The data to be displayed can be set by the parameter. Initial value: Deviation, Heating-side control output (in Heating/cooling control) | | | | | | | | | | | | |
| (6) | Event indicator (orange) | Lit when the alarms 1 to 4 occur. Event displays other than alarms can be set by the parameter. | | | | | | | | | | | | |
| (7) | Key navigation indicator (green) | Lit or blinks when the Up/Down or Left/Right arrow key operation is possible. | | | | | | | | | | | | |
| (8) | Parameter display level indicator (green) | Displays the setting conditions of the parameter display level function. <table border="1"> <thead> <tr> <th>Parameter display level</th> <th>EASY</th> <th>PRO</th> </tr> </thead> <tbody> <tr> <td>Easy setting mode</td> <td>Lit</td> <td>Unlit</td> </tr> <tr> <td>Standard setting mode</td> <td>Unlit</td> <td>Unlit</td> </tr> <tr> <td>Professional setting mode</td> <td>Unlit</td> <td>Lit</td> </tr> </tbody> </table> | Parameter display level | EASY | PRO | Easy setting mode | Lit | Unlit | Standard setting mode | Unlit | Unlit | Professional setting mode | Unlit | Lit |
| Parameter display level | EASY | PRO | | | | | | | | | | | | |
| Easy setting mode | Lit | Unlit | | | | | | | | | | | | |
| Standard setting mode | Unlit | Unlit | | | | | | | | | | | | |
| Professional setting mode | Unlit | Lit | | | | | | | | | | | | |
| (9) | Status indicator (green and red) | Displays the operating conditions and control status. <table border="1"> <thead> <tr> <th>Indicator</th> <th>Description</th> </tr> </thead> <tbody> <tr> <td>REM</td> <td>Lit when in remote mode (REM).</td> </tr> <tr> <td>STOP</td> <td>Lit when in stop mode (STOP).</td> </tr> <tr> <td>MAN</td> <td>Lit when in manual mode (MAN). Blinks during auto-tuning.</td> </tr> </tbody> </table> | Indicator | Description | REM | Lit when in remote mode (REM). | STOP | Lit when in stop mode (STOP). | MAN | Lit when in manual mode (MAN). Blinks during auto-tuning. | | | | |
| Indicator | Description | | | | | | | | | | | | | |
| REM | Lit when in remote mode (REM). | | | | | | | | | | | | | |
| STOP | Lit when in stop mode (STOP). | | | | | | | | | | | | | |
| MAN | Lit when in manual mode (MAN). Blinks during auto-tuning. | | | | | | | | | | | | | |
| (10) | Security indicator (red) | Lit if a password is set. The setup parameter settings are locked. | | | | | | | | | | | | |
| (11) | Ladder operation indicator (green) | Lit while the ladder operation is executed. | | | | | | | | | | | | |

| No. in figure | Name | Description |
|---------------|--|--|
| (1) | UT35A: DISPLAY key UT32A: DISP key | Used to switch the Operation Displays. Press the key in the Operation Display to switch the provided Operation Displays. Press the key in the Menu Display or Parameter Setting Display to return to the Operation Display. |
| (2) | UT35A: PARAMETER key UT32A: PARA key | Hold down the key for 3 seconds to move to the Operation Parameter Setting Display. Hold down the key and the Left arrow key simultaneously for 3 seconds to move to the Setup Parameter Setting Display. Press the key in the Parameter Setting Display to return to the Menu Display. Press the key once to cancel the parameter setting (setpoint is blinking). |
| (3) | SET/ENTER key Up/Down/Left/Right arrow keys | SET/ENTER key Press the key in the Menu Display to move to the Parameter Setting Display of the Menu. Press the key in the Parameter Setting Display to transfer to the parameter setting mode (setpoint is blinking), and the parameter can be changed. Press the key during parameter setting mode to register the setpoint. Up/Down/Left/Right arrow keys Press the Left/Right arrow keys in the Menu Display to switch the Displays. Press the Up/Down/Left/Right arrow keys in the Parameter Setting Display to switch the Displays. Press the Up/Down arrow keys during parameter setting mode (setpoint is blinking) to change a setpoint. Press the Left/Right arrow keys during parameter setting mode (setpoint is blinking) to move between digits according to the parameter. |
| (4) | Light-loader interface | It is the communication interface for the adapter cable used when setting and storing parameters from a PC. The LL50A Parameter Setting Software (sold separately) is required. |
| (5) | A/M key | Used to switch between AUTO and MAN modes. The setting is switched between AUTO and MAN each time the key is pressed. |
| (6) | User function keys | The UT35A has F1, F2, and Fn keys. The UT32A has only the Fn key. The user can assign a function to the key. The function is set by the parameter. |

Note: The communication connector (maintenance port) for LL50A Parameter Setting Software is on the top of the unit.

2. Setup Procedure

The following flowchart shows the setup procedure for UT35A and UT32A.

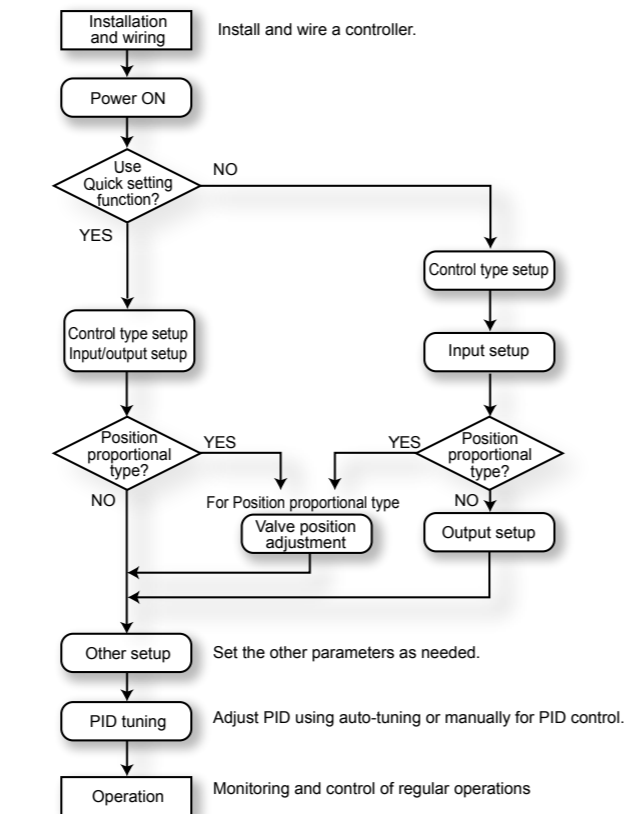

3. Quick Setting Function (Setting of Input and Output)

The Quick setting function is a function to easily set the basic function of the controller. Turn on the controller to start the Quick setting function. This function allows you to easily set the control type, input, and output, and quickly start the control action. The items (parameters) to be set by Quick setting function are as follows.
(1) Control type (PID control, Heating/cooling control, etc.)
(2) Input function (PV input type, range, scale (at voltage input), etc.)
(3) Output function (control output type and cycle time)

After turning on the controller, first decide whether or not to use the Quick setting function.

Operation in Initial Display

- Press the SET/ENTER key while YES is displayed to start the Quick setting function.
- If you change YES to NO and press the SET/ENTER key, Operation Display will appear without starting the Quick setting function.

Operation for Setting

- To select the parameter setting displayed as the initial value, press the Down arrow key to move to the next parameter.

Flow of Quick Setting Function

In Quick setting mode, the parameter guide appears on PV display. This guide can be turned on/off with the Fn key.

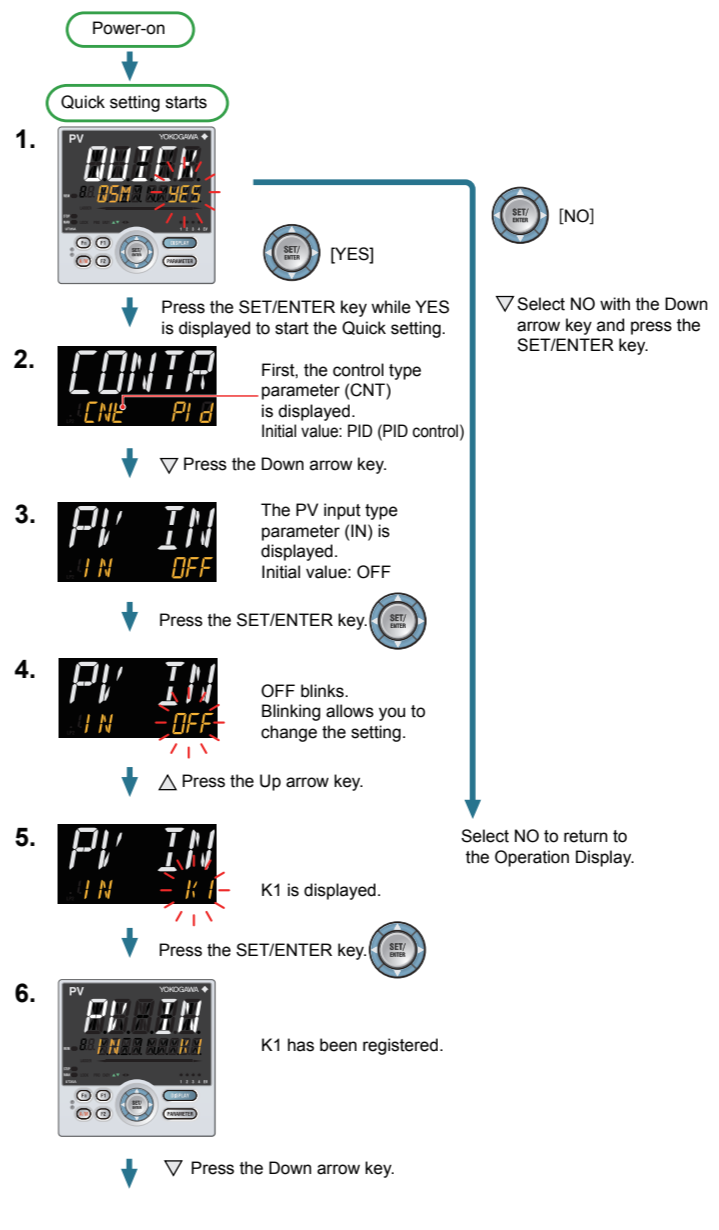

To change and set the parameter setting, press the SET/ENTER key to start the setpoint blinking. The blinking state allows you to make changes (setting mode). Use the Up/Down/Left/Right arrow keys to change the setpoint. Press the SET/ENTER key to register the setting.

Making Settings Using Quick Setting Function

Example: Setting to PID control, thermocouple type K (range of 0.0 to 500.0°C), and current control output

For the detailed procedure and switching of displays, see "Flow of Quick Setting Function" below. For the parameters to set, see the next page.

- Press the SET/ENTER key while YES for QSM (Quick setting mode) is displayed.
- Set the control type parameter (CNT) to PID (PID control).
- Set the PV input type parameter (IN) to K1 (-270.0 to 1370.0 °C).
- Set the PV input unit parameter (UNIT) to C (Degree Celsius).
- Set the maximum value of PV input range parameter (RH) to 500.0.
- Set the minimum value of PV input range parameter (RL) to 0.0.
- Set the output type selection parameter (OT) to OUT terminals (current=0.02).
- Finally, EXIT is displayed. Change NO to YES and press the SET/ENTER key to complete the setup. Operation Display appears.



Parameters to be set

Control Type

| Parameter Symbol | Name of Parameter | Setting Range |
|------------------|-------------------|--|
| CNT | Control type | PID: PID control ONOF: ON/OFF control (1 point of hysteresis) ONOF2: ON/OFF control (2 points of hysteresis) ZP2L: Two-position two-level control H/C: Heating/cooling control |

Note: Some setpoints may not be displayed depending on the model and suffix codes.

Input Function

| Parameter Symbol | Name of Parameter | Setting Range |
|------------------|---------------------------------------|---|
| IN | PV input type | OFF: Disable K1: -270.0 to 1370.0 °C / -450.0 to 2500.0 °F K2: -270.0 to 1000.0 °C / -450.0 to 2300.0 °F K3: -200.0 to 500.0 °C / -200.0 to 1000.0 °F J: -200.0 to 1200.0 °C / -300.0 to 2300.0 °F T1: -270.0 to 400.0 °C / -450.0 to 750.0 °F T2: 0.0 to 400.0 °C / -200.0 to 750.0 °F B: 0.0 to 1800.0 °C / 32 to 3300 °F S: 0.0 to 1700.0 °C / 32 to 3100 °F R: 0.0 to 1700.0 °C / 32 to 3100 °F N: -200.0 to 1300.0 °C / -300.0 to 2400.0 °F E: -270.0 to 1000.0 °C / -450.0 to 1800.0 °F L: -200.0 to 900.0 °C / -300.0 to 1600.0 °F U1: -200.0 to 400.0 °C / -300.0 to 750.0 °F U2: 0.0 to 400.0 °C / -200.0 to 1000.0 °F W: 0.0 to 2300.0 °C / 32 to 4200 °F PL2: 0.0 to 1390.0 °C / 32.0 to 2500.0 °F P2040: 0.0 to 1900.0 °C / 32 to 3400 °F WRE: 0.0 to 2000.0 °C / 32 to 3600 °F JPT1: -200.0 to 500.0 °C / -300.0 to 1000.0 °F JPT2: -150.00 to 150.00 °C / -200.0 to 300.0 °F PT1: -200.0 to 850.0 °C / -300.0 to 1560.0 °F PT2: -200.0 to 500.0 °C / -300.0 to 1000.0 °F PT3: -150.00 to 150.00 °C / -200.0 to 300.0 °F 0.4-2V: 0.400 to 2.000 V 1-5V: 1.000 to 5.000 V 4-20: 4.00 to 20.00 mA 0-2V: 0.000 to 2.000 V 0-10V: 0.00 to 10.00 V 0-20: 0.00 to 20.00 mA -1020: -10.00 to 20.00 mV 0-100: 0.0 to 100.0 mV |
| UNIT | PV input unit | -: No unit, C: Degree Celsius -: No unit, -: No unit, -: No unit, F: Degree Fahrenheit |
| RH | Maximum value of PV input range | Depends on the input type. - For temperature input - Set the temperature range that is actually controlled. (RL<RH) - For voltage / current input - Set the range of a voltage / current signal that is applied. |
| RL | Minimum value of PV input range | The scale across which the voltage / current signal is actually controlled should be set using the maximum value of input scale (SH) and minimum value of input scale (SL). (Input is always 0% when RL = RH.) |
| SDP | PV input scale decimal point position | 0: No decimal place 3: Three decimal places 1: One decimal place 4: Four decimal places 2: Two decimal places |
| SH | Maximum value of PV input scale | -19999 to 30000, (SL<SH), SH - SL ≤ 30000 |
| SL | Minimum value of PV input scale | |

Note 1: SDP, SH, and SL are displayed only for voltage/current input.
Note 2: W: W-5%Re/W-26%Re (Hoskins Mfg. Co.), ASTM E988

Output Function

| Parameter Symbol | Name of Parameter | Setting Range |
|------------------|--|--|
| OT | Output type selection | Control output or Heating-side control output (Lower two digits) 00: OFF 01: OUT terminals (voltage pulse) 02: OUT terminals (current) 03: OUT terminals (relay) 06: OUT2 terminals (relay) 07: RET/OUT2 terminals (voltage pulse) 08: RET/OUT2 terminals (current) Cooling-side control output (Upper two digits) 00: OFF 01: OUT terminals (voltage pulse) 02: OUT terminals (current) 03: OUT terminals (relay) 06: OUT2 terminals (relay) 07: RET/OUT2 terminals (voltage pulse) 08: RET/OUT2 terminals (current) |
| CT | Control output cycle time | Heating-side control output cycle time (in Heating/cooling control) 0.5 to 1000.0 s |
| CTc | Cooling-side control output cycle time | (in Heating/cooling control) |

4. Adjusting Valve Position Automatically (for a Position Proportional Type Controller Only)

The following operating procedure describes how to input feedback signals from the control valve and adjust the fully-open and fully-closed positions of the control valve automatically. The fully-open and fully-closed positions of the valve can be adjusted automatically by inputting feedback signals from the valve. To adjust the valve position, you need to carry out the connection and bring the controller into manual mode. For the connection, see "6. Terminal Wiring Diagrams" in "Installation and Wiring", and for the manual mode, see "5. Switching between AUTO and MAN" in "Operations."

1. Show the Operation Display.
MAN is lit
2. Hold down the keys for 3 seconds.
* When a password is set, PASS is displayed. If the correct password is not entered, setup parameters cannot be changed.
CTL menu is displayed.
3. Press the Right arrow key until OUT menu appears.
OUT menu is displayed.
4. Press the SET/ENTER key.
The parameter V.AT (automatic valve position adjustment) is displayed.
5. Press the SET/ENTER key.
OFF blinks.
6. Press the Up arrow key.
ON is displayed. Blinks during the change.
7. Press the SET/ENTER key.
ON has been registered and the automatic adjustment of the valve position starts. V.AT blinks during the automatic adjustment. After the adjustment is completed, press the DISPLAY key or DISP key once to return to the Operation Display.

- When the adjustment is completed normally, the indication automatically returns to OFF.
- When V.A.T.E appears on PV display, it indicates an error. Check the wiring for feedback input and perform the automatic adjustment again. To perform a valve adjustment manually, see User's Manual (IM 05P01D31-01EN).

5. Setting Alarm Type

The following operating procedure shows an example of changing the alarm-1 type (factory default: PV high limit alarm) to PV low limit alarm (setpoint: 02).

1. Show the Operation Display.
2. Hold down the key for 3 seconds.
MODE menu is displayed.
3. Press the Right arrow key until ALRM menu appears.
ALRM menu is displayed.
4. Press the SET/ENTER key.
The parameter AL1 (alarm-1 type) is displayed.

5. The last digit of the setpoint blinks.
Change the setpoint using the Up/Down arrow keys to increase and decrease the value and the Left/Right arrow keys to move between digits.
Press the SET/ENTER key.
6. The alarm-1 type setpoint 02 (PV low limit) is registered.
After the setup is completed, press the DISPLAY key or DISP key once to return to the Operation Display.

- To change the alarm type, change the last 2 digits of the 5-digit value.
- Stand-by action and excitation are turned on or off by selecting 1 or 0. (See "Setting Display of Alarm Type.")
- For the latch action, see User's Manual (IM 05P01D31-01EN).

| Alarm Type (Alarm Setpoint) | Alarm Action (Energized) | Alarm Action (De-energized) |
|--|---|--|
| No alarm (00) | - | - |
| PV high limit (01) Analog input PV high limit (19) | Hysteresis Open (unit) ↑ Closed (lit) pv Alarm setpoint | Hysteresis Closed (unit) ↓ Open (lit) pv Alarm setpoint |
| PV low limit (02) Analog input PV low limit (20) | Hysteresis Closed (lit) ↓ Open (unit) Alarm setpoint pv | Hysteresis Open (lit) ↑ Closed (unit) Alarm setpoint pv |
| SP high limit (03) Target SP high limit (09) | Hysteresis Open (unit) ↑ Closed (lit) SP or Target SP | Hysteresis Closed (unit) ↓ Open (lit) SP or Target SP |
| SP low limit (04) Target SP low limit (10) | Hysteresis Closed (lit) ↓ Open (unit) Alarm setpoint SP or Target SP | Hysteresis Open (lit) ↑ Closed (unit) Alarm setpoint SP or Target SP |
| Deviation high limit (05) Target SP deviation high limit (11) | Hysteresis Open (unit) ↑ Closed (lit) PV → Deviation setpoint SP or Target SP ⊕ | Hysteresis Closed (unit) ↓ Open (lit) PV → Deviation setpoint SP or Target SP ⊕ |
| Deviation low limit (06) Target SP deviation low limit (12) | Hysteresis Closed (lit) ↓ Open (unit) Deviation setpoint → PV ⊖ SP or Target SP | Hysteresis Open (lit) ↑ Closed (unit) Deviation setpoint → PV ⊖ SP or Target SP |
| Deviation high and low limits (07) Target SP deviation high and low limits (13) | Hysteresis Hysteresis Closed (lit) ↓ Open (unit) ↑ Closed (lit) Deviation setpoint → PV | Hysteresis Hysteresis Open (lit) ↑ Closed (unit) ↓ Open (lit) Deviation setpoint → PV |
| Deviation within high and low limits (08) Target SP deviation within high and low limits (14) | Hysteresis Hysteresis Open (unit) ↑ Closed (lit) ↓ Open (unit) Deviation setpoint → PV | Hysteresis Hysteresis Closed (unit) ↓ Open (lit) ↑ Closed (unit) Deviation setpoint → PV |
| Control output high limit (15) Cooling-side control output high limit (17) | Hysteresis Open (unit) ↑ Closed (lit) Output Alarm setpoint | Hysteresis Closed (unit) ↓ Open (lit) Output Alarm setpoint |
| Control output low limit (16) Cooling-side control output low limit (18) | Hysteresis Closed (lit) ↓ Open (unit) Alarm setpoint Output | Hysteresis Open (lit) ↑ Closed (unit) Alarm setpoint Output |
| Feedback input high limit (27) | Fault diagnosis alarm (30) Burnout of PV input, ADC failure, RJC error. | |
| Feedback input low limit (28) | FAIL (31) | |
| PV velocity (29) | For the factory default, the contact output is turned ON in normal operation, OFF at the time of FAIL. Control output: OFF or 0%, Alarm output: OFF | |

Note 1: "Open/closed" shows status of relay contact, and "lit/unlit" shows status of EV (event) lamp.
Note 2: ⊕ Positive setpoint. ⊖ Negative setpoint.

Setting Display of Alarm Type

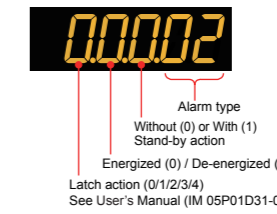

Stand-by Action

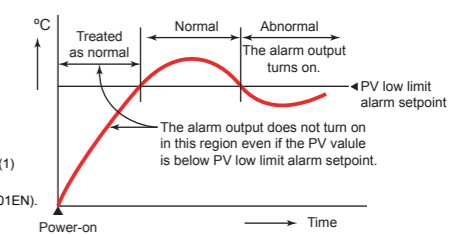

6. Setting Alarm Setpoint

The following operating procedure shows an example of setting the alarm-1 setpoint of group 1 to 180.0.

Before setting the alarm setpoint, check the alarm type. To change the alarm type, see "5. Setting Alarm Type."

1. Show the Operation Display.
2. Display MODE menu with the same procedure as described in Setting Alarm Type.
Press the Right arrow key.
3. SP menu is displayed.
Press the SET/ENTER key.
Press the Down arrow key until A1 appears.
4. The parameter A1 is displayed. A1 to A4 represent the alarm-1 to -4 setpoints.
Group

- Each parameter and group can be changed in the Parameter Setting Displays of alarms using arrow keys.
- △▽ Up/Down arrow keys: parameters
- ◀▶ Left/Right arrow keys: groups

Display the parameter and group that need to be changed.

5. Blinks during the change.
Change the setpoint using the Up/Down arrow keys to increase and decrease the value and the Left/Right arrow keys to move between digits.
Press the SET/ENTER key.
6. The setpoint has been registered. After the setup is completed, press the DISPLAY key or DISP key once to return to the Operation Display.

Initializing parameter values

Parameters that you have changed can be initialized to factory default values or user default values. For details, see "Parameter Initialization" in the User's Manual (IM 05P01D31-01EN).

Changing the parameter display levels

This operation guide does not explain all the parameters. To display all the parameters, you need to change the parameter display level to professional setting mode. For details, see "Setting Security Functions" in the User's Manual (IM 05P01D31-01EN).

This operation guide describes key entries for operating the UT35A and UT32A. Although the display of UT35A is used in this guide, UT32A can be operated similarly. For operations using external contact inputs, see "DI" of "6. Terminal Wiring Diagrams" in "Installation and Wiring."
If you cannot remember how to carry out an operation during setting, press the DISPLAY key or DISP key once. This brings you to the display (Operation Display) that appears at power-on.
The scrolling guide is displayed on PV display in the Parameter Setting Display. This guide can be turned on/off with the Fn key.
For details of the each function, refer to the electronic manual. Manuals can be downloaded or viewed at the following URL.

<http://www.yokogawa.com/ns/ut/im/>

Contents

- Monitoring-purpose Operation Displays Available during Operation
- Setting Target Setpoint (SP)
- Performing/Canceling Auto-tuning
- Selecting Target Setpoint Numbers (SPNO.)
- Switching between AUTO and MAN
- Switching between RUN and STOP
- Switching between REM (Remote) and LCL (Local)
- Manipulating Control Output in Manual Mode
- Troubleshooting

1. Monitoring-purpose Operation Displays Available during Operation

■ Operation Display Switching Diagram for Standard and Position Proportional Types

- SP Display**
Displays the measured input value on PV display.
Displays the target setpoint (SP) on Setpoint display (SP can be changed).
- OUT Display**
Displays the measured input value on PV display.
Displays the control output value (OUT) on Setpoint display (OUT can be changed in manual mode).
Displays the valve's feedback input value (at 0 to 100% valve opening) in Position proportional control.

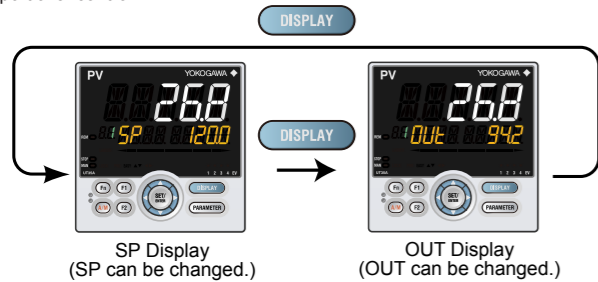

■ Operation Display Switching Diagram for Heating/Cooling Type

- SP Display**
Displays the measured input value on PV display.
Displays the target setpoint (SP) on Setpoint display (SP can be changed).
- OUT Display**
Displays the measured input value on PV display.
Displays the control output values (C.H.) of heating and cooling sides on Setpoint display (C.H. can be changed in manual mode).

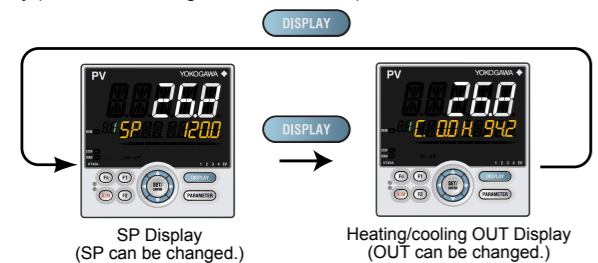

After showing the OUT Display, press the DISPLAY key or DISP key to show the following displays conditionally. For details, see User's Manual (IM 05P01D31-01EN).

Standard, Position Proportional, and Heating/Cooling Types

- SELECT Displays 1 to 5 (which appear when registered)
- Analog Input Display (display only) (factory default: non-display)
- Position Proportional Computation Output Display (display only) (factory default: non-display)
- PID Number Display (display only) (factory default: non-display)
- Heater Break Alarm-1 Current Display (display only) (for heater break alarm option only)
- Heater Break Alarm-2 Current Display (display only) (for heater break alarm option only)

2. Setting Target Setpoint (SP)



- Show the SP Display (Operation Display). (This is an example of setting the target setpoint to 150.0).
- Press the SET/ENTER key to start the last digit of the setpoint blinking. Blinking allows you to change the value.
- Use the Left/Right arrow keys to move between digits and the Up/Down arrow keys to increase and decrease the value.
- When the required value is displayed, press the SET/ENTER key to register the setpoint.

3. Performing/Canceling Auto-tuning

Auto-tuning should be performed after setting a target setpoint. Make sure that the controller is in automatic mode (AUTO) and in run mode (RUN) before auto-tuning. For setting to AUTO, see "5. Switching between AUTO and MAN," and for setting to RUN, see "6. Switching between RUN and STOP." If the setpoint is known in advance or auto-tuning does not find any appropriate PID constants, set the PID manually. For setting the PID manually, see User's Manual (IM 05P01D31-01EN).



Do not perform auto-tuning for the following processes. Tune PID manually.

- Processes with fast response such as flow rate control and pressure control.
- Processes which do not allow the output to be turned on and off even temporarily.
- Processes which prohibit severe output changes at control valves (or other actuators).
- Processes in which product quality can be adversely affected if PV values fluctuate beyond their allowable ranges.

- Show the Operation Display.



- Hold down the PARAMETER key or PARA key for 3 seconds to display MODE menu.



- In cases where the communication is specified, the parameter R.L (REMOTE/LOCAL switch) is displayed.

- Press the Down arrow key until the parameter AT appears.



- The parameter AT (auto-tuning switch) is displayed.



- Press the SET/ENTER key.



OFF blinks.



- Press the Up/Down arrow keys to display the required setpoint.

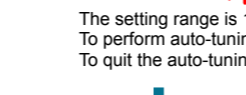

Blinks during the change.



- The setpoint has been registered. This starts auto-tuning. The limiter can be set to the output during auto-tuning. For details, see User's Manual (IM 05P01D31-01EN).

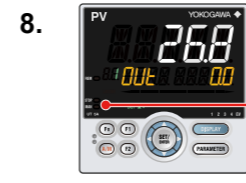

The MAN lamp goes off, which means that the auto-tuning completed normally.

4. Selecting Target Setpoint Numbers (SPNO.)

The following operating procedure shows an example of changing the target setpoint number (SPNO.) from 1 to 2. Each SP has its PID group. The PID group set for the parameter PIDN (PID number selection) is used.

- Show the Operation Display.



- Hold down the PARAMETER key or PARA key for 3 seconds to display MODE menu.

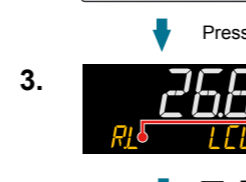

- In cases where the communication is specified, the parameter R.L (REMOTE/LOCAL switch) is displayed.



- Press the Down arrow key until the parameter SPNO. appears.



- The parameter SPNO. (SP number selection) is displayed.



- Press the SET/ENTER key.



- Change the setpoint using the Up/Down arrow keys. Blinks during the change.



- The setpoint has been registered. Press the DISPLAY key or DISP key once to return to the Operation Display.

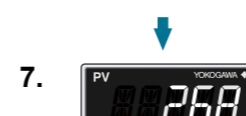

- SPNO. has been changed to 2.

5. Switching between AUTO and MAN

AUTO and MAN switching can be performed using any of the following: (1) A/M key, (2) Contact input, (3) Communication, and (4) User function key. The figure below shows a direct operation using the A/M key. When AUTO and MAN switching function is assigned to the contact input, and the contact input is ON, the switching by key operation cannot be performed. For details, see User's Manual (IM 05P01D31-01EN).

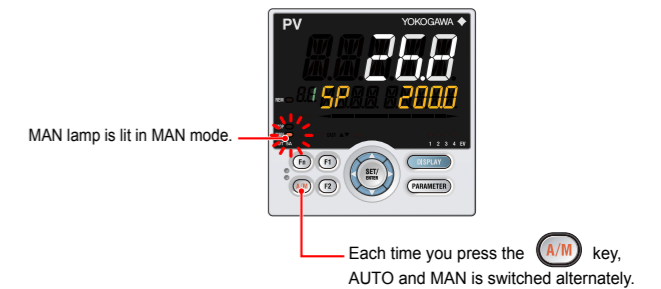

When AUTO is switched into MAN, the control output value in AUTO mode is held. The controller can be operated manually from the hold value. If the manual preset output is set (MPON parameter ≠ OFF), the controller can be operated manually from the arbitrary output value (MPO1 to MPO5 parameters).

6. Switching between RUN and STOP

RUN and STOP switching can be performed using any of the following: (1) Contact input, (2) Parameter, (3) Communication, and (4) User function key. The following shows an example of switching using the contact input. (The switching function is assigned to DI2 contact for the factory default.) For details of other switching methods and the display appearing when the operation is started, see User's Manual (IM 05P01D31-01EN).

When the controller is stopped, input and outputs are as follows:

| | |
|----------------|--|
| PV input | Displays the PV value. |
| Control output | Displays the preset output value. The preset output value is set for each PID group. |
| Alarm output | Turns the output on in case of an alarm. |

Display in STOP mode

"STOP" is displayed on Symbol display and "preset output value" is displayed on Data display.

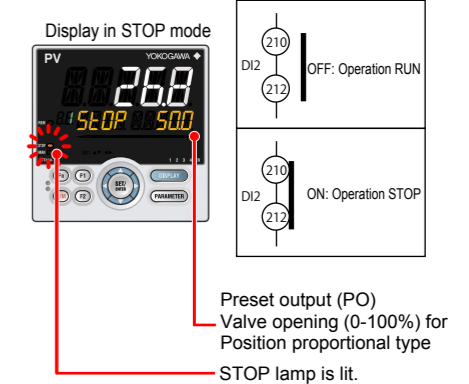

Display in STOP mode in Heating/cooling control

"Cooling-side preset output value" is displayed on the left side of the "ST" symbol, and "Heating-side preset output value" is on the right side.

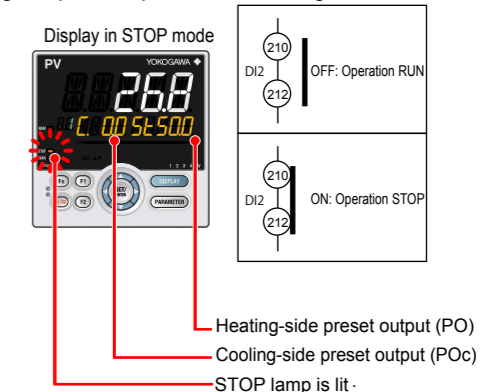

7. Switching between REM (Remote) and LCL (Local)

Remote and local switching can be performed using any of the following:
 (1) Contact input, (2) Parameter, (3) Communication, and (4) User function key.

LCL (Local)

Control is performed using the target setpoint set on the controller.

REM (Remote)

Control is performed using a setpoint via communication for the target setpoint. The following shows an example of switching from local to remote using the parameter. (Only in cases where the communication is specified.)

For details of other switching methods, see User's Manual (IM 05P01D31-01EN).

- The PID group for the local SP number is used as PID in remote mode.

NOTE

When the contact input is ON, operation cannot be performed using the parameter, communication, or key. When the contact input is OFF and the setting is switched using the parameter, communication, or key, the last switching operation is performed.

1. Show the Operation Display.

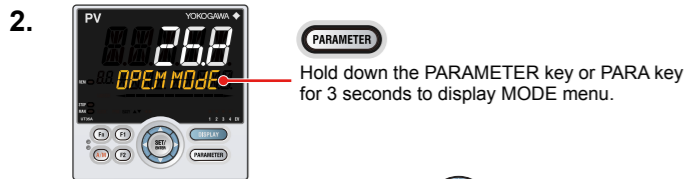

2. Press the SET/ENTER key.

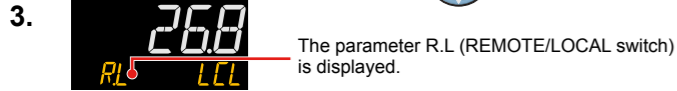

3. Press the SET/ENTER key.

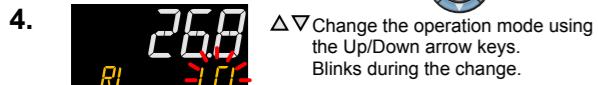

4. Press the SET/ENTER key.



8. Manipulating Control Output in Manual Mode

NOTE

In manual mode, control output is manipulated by operating the keys (the value is changed using the Up/Down arrow keys, then outputted as it is). Even if the SET/ENTER key is not pressed, the control output value changes according to the displayed value. In stop mode (when the STOP lamp is lit), control output cannot be manipulated.

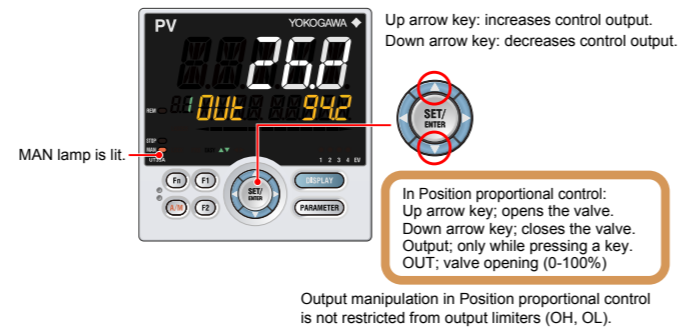

Manual operation in Heating/cooling control

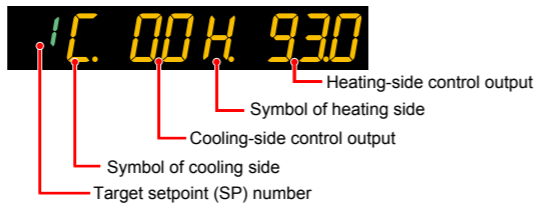

Up arrow key: concurrently decreases cooling-side control output and increases heating-side control output.
 Down arrow key: concurrently increases cooling-side control output and decreases heating-side control output.
 (Either none of the heating-side and cooling-side outputs are presented, or both of them are presented according to the dead band setting.)

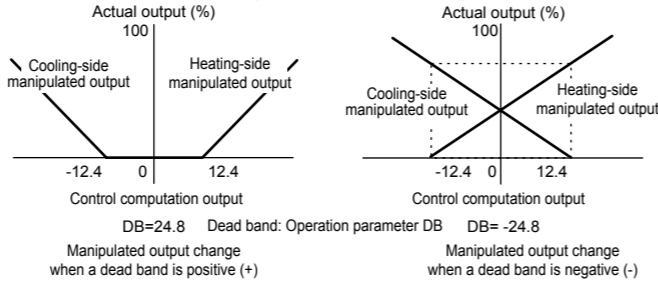

9. Troubleshooting

■ Troubleshooting Flow

If the Operation Display does not appear after turning on the controller's power, check the procedures in the following flowchart. If a problem appears to be complicated, contact our sales representatives.

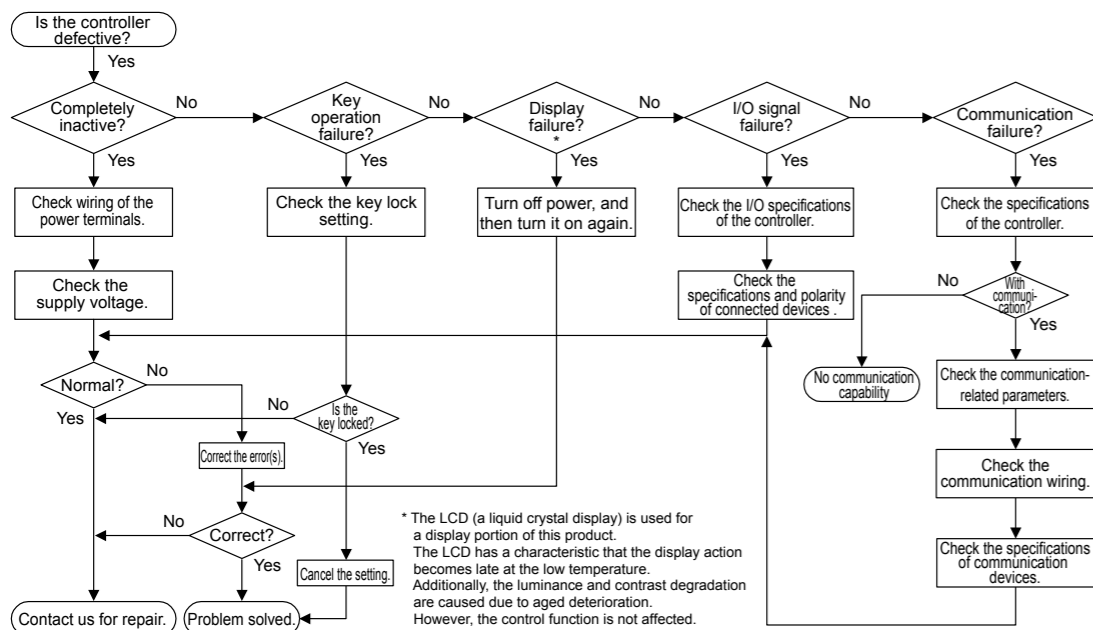

* The LCD (a liquid crystal display) is used for a display portion of this product. The LCD has a characteristic that the display action becomes late at the low temperature. Additionally, the luminance and contrast degradation are caused due to aged deterioration. However, the control function is not affected.

■ Remedies if Power Failure Occurs during Operations

- Instantaneous power failure within 20 ms. A power failure is not detected. Normal operation continues.
- Power failure for less than about 5 seconds, or for about 5 seconds or more. Affects the "settings" and "operation status." For details, see User's Manual (IM 05P01D31-01EN).

NOTE

Write down the settings of parameters for a repair request.

■ Errors at Power On

The errors shown below may occur in the fault diagnosis when the power is turned on. (For details of Setpoint display and input/output action when each error occurs, see User's Manual (IM 05P01D31-01EN).)

| PV display (Operation Display) | Setpoint display (Operation Display) | Status indicator (Operation Display) | Parameter that displays error details | Error description | Cause and diagnosis | Remedy |
|--------------------------------|--|---|---------------------------------------|--------------------------------------|---|---|
| Indication off | Indication off | — | — | Faulty MCU RAM / MCU ROM | MCU RAM / MCU ROM are failed. | Faulty. Contact us for repair. |
| ERR | SYS - - - - | — | Setup parameter (PA.ER) | System data error | System data is corrupted. | Faulty. Contact us for repair. |
| | PAR 0004 (for user default value error only) | | | User (parameter) default value error | User parameter is corrupted. Initialized to factory default value. | Check and reconfigure the initialized setting parameters. Error indication is erased when the power is turned on again. |
| | PAR 0010 (for setup parameter error only) | | | Setup parameter error | Setup parameter data is corrupted. Initialized to user default value. | |
| | PAR 0020 (for operation parameter error only) | | | Operation parameter error | Operation parameter data is corrupted. Initialized to user default value. | |
| Normal indication | Normal indication | Rightmost decimal point on PV display blinks. | Setup parameter (PA.ER) | Calibration value error | Initialized to calibrated default value because of corrupted factory default value. | Faulty. Contact us for repair. |
| | | | | Faulty FRAM | Data writing (storing) to FRAM is impossible. | |
| Normal indication | Normal indication | LADDER lamp blinks | Setup parameter (LA.ER) | Corrupted ladder program | Ladder program is corrupted. Operates without ladder program. | Download the ladder program again. |
| Normal indication | 0.000 00000 (Decimal point on the left of the Symbol display blinks) | — | Setup parameter (OP.ER) | User profile error | User profile is corrupted. | Download the user profile again. |
| Normal indication | Normal indication | — | Setup parameter (OP.ER) | User profile error | User profile is corrupted. | Download the user profile again. |
| | | | | | | |

■ Errors during Operation

The errors shown below may occur during operation. (For input/output action when each error occurs, see User's Manual (IM 05P01D31-01EN).)

| PV display (Operation Display) | Setpoint display (Operation Display) | Status indicator (Operation Display) | Parameter that displays error details | Error description | Cause and diagnosis | Remedy |
|---|--|---|---------------------------------------|---|---|--|
| AD.ERR | Normal indication (Note) | — | Setup parameter (AD1.E) | Analog input terminal ADC error +PV input | Analog input terminal AD value error | Faulty. Contact us for repair. |
| RJC.E (Displays RJC. E and PV alternately.) | Normal indication (Note) | — | Setup parameter (AD1.E) | Universal input terminal RJC error +PV input | Universal input terminal RJC error | Faulty. Contact us for repair. Set the parameter RJC to OFF to erase error indication. |
| B.OUT | Normal indication (Note) | — | Setup parameter (AD1.E) | Analog input terminal burnout error +PV input | Analog input terminal sensor burnout | Check wiring and sensor. Error indication is erased in normal operation. |
| | | | | Setup parameter (PV1.E) | PV input burnout error | Burnout of analog input connected to PV |
| OVER-OVER | Normal indication | — | Setup parameter (PV1.E) | PV input over-scale PV input under-scale (PV values out of -5 to 105%) | PV input is out of -5 to 105%. Also occurs when the data out of range which is the ladder calculation result is input. | Check analog input value or ladder program. |
| Normal indication | OUT - - - - | — | Setup parameter (AD2.E) | Feedback input resistor/current burnout | Feedback input burnout | Check wiring of feedback input resistor/current. Error indication is erased in normal operation. |
| Normal indication | Normal indication | LADDER lamp blinks | Setup parameter (LA.ER) | Ladder calculation overflow | Floating point computation for ladder calculation is infinite. | Check the ladder program. |
| | | | | Load factor over 100% | Computation does not end within the control period (load factor is 100% or more). | Change the control period or reduce the number of steps for the ladder program. |
| | | | | Load factor over 200% (Forced end) | Computation does not end within the control period (load factor is 200% or more). | Change the control period or reduce the number of steps for the ladder program. |
| | | | | Ladder program error | Ladder program is corrupted. | Download the ladder program again. If the error indication is still not erased, there is a fault. Contact us for repair. |
| Normal indication | 0.000 00000 (Decimal point on the left of the Symbol display blinks) | — | Setup parameter (OP.ER) | Peer-to-peer communication error | Peer-to-peer communication error | Check that the target devices are connected correctly. Recovery at normal receipt. |
| ATE | Normal indication | — | Setup parameter (PV1.E) | Auto-tuning time-out | Auto-tuning does not end even when 24 hours have elapsed after the start of tuning. | Check the process. Hold down any key to erase the error indication |
| VAT.E | Normal indication | — | Setup parameter (AD2.E) | Valve position automatic adjustment error | Fully-closed valve position is equal to or larger than the fully-open valve position after automatic valve position adjustment is performed. | Check wiring and valve. Hold down any key to erase the error indication. |
| Normal indication | 0.000 00000 (Decimal point on the left of the Symbol display blinks) | — | Setup parameter (OP.ER) | Communication error (RS-485 communication) | Framing parity error Buffer overflow Inter-character time-out Checksum error (PC link communication with checksum) CRC check error (Modbus/RTU) LRC check error (Modbus/ASCII) | Check the communication parameters. Recovery at normal receipt. Hold down any key to stop blinking. |
| Normal indication | 0.000 00000 (Decimal point on the left of the Symbol display blinks) | — | Setup parameter (OP.ER) | Communication error (coordinated operation) | Inconsistency of loop between coordinated master and slaves Communication from coordinated master is interrupted for 2 seconds. | Check the communication parameters. Recovery at normal receipt. Change from remote to local mode to stop blinking. When the mode is changed from remote to local, SP tracking does not work even if it is set to ON. |
| Normal indication | 0.000 00000 (Decimal point on the left of the Symbol display blinks) | — | Setup parameter (OP.ER) | User profile error | User profile is corrupted. | Download the user profile again. |
| Normal indication | Normal indication | Rightmost decimal point on Symbol display blinks. | Setup parameter (PA.ER) | Faulty FRAM | Writing (storing) data to FRAM is impossible. | Faulty. Contact us for repair. |
| Undefined | Undefined | — | — | Faulty MCU / DCU (ROM / RAM error, corrupted) | MCU / DCU is corrupted. | Faulty. Contact us for repair. |

Note: When an error occurs in input shown in Analog input display (Operation display), Setpoint display shows the same symbol as the PV display.

This operation guide describes the functions of parameters briefly. The parameter symbols listed are in the order shown on the display in each group of menu symbols. In addition, each parameter table has a "User Setting" column, where you can record your setpoints when setting them in the controller. The scrolling guide is displayed on PV display in the Parameter Setting Display. This guide can be turned on/off with the Fn key. For details of the each function, refer to the electronic manual. Manuals can be downloaded or viewed at the following URL.

<http://www.yokogawa.com/ns/ut/im/>

Operation Parameters

Hold down the PARAMETER key or PARA key for 3 seconds to move from the Operation Display to the Operation Parameter Setting Display. Press the DISPLAY key or DISP key once to return to the Operation Display.

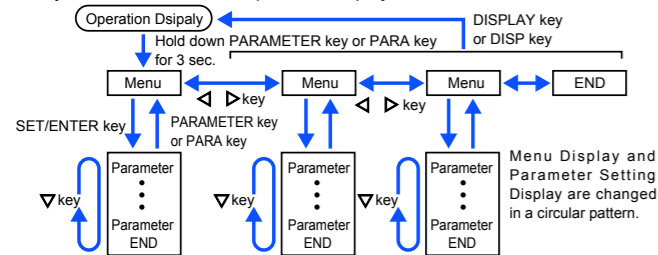

The parameter groups can be switched using ◀, ▶ keys.

Move to the Setup Parameter Setting Display:

Hold down the PARAMETER key or PARA key and the Left arrow key simultaneously for 3 sec.

Operation for Setting

- To select the parameter setting displayed as the initial value, press the Down arrow key to move to the next parameter.
- To change and set the parameter setting, press the SET/ENTER key to start the setpoint blinking. The blinking state allows you to make changes (setting mode). Use the Up/Down/Left/Right arrow keys to change the setpoint. Press the SET/ENTER key to register the setting.

Note that there are some parameters which are not displayed depending on the model and suffix codes, control type (CNT), etc. The parameters for professional setting mode (LEVEL: PRO) are not described in this manual. See User's Manual (IM 05P01D31-01EN).

Operation Mode

Menu symbol: *MODE* (MODE)

| Parameter symbol | Name of Parameter | Setting Range | Initial value | User setting | Display level |
|---------------------|---------------------|---|---------------|--------------|---------------|
| <i>SP</i> (S.R) | STOP/RUN switch | STOP: Stop mode RUN: Run mode Preset output (PO) is generated in STOP mode. Default: Not displayed. STOP/RUN switch is assigned to contact input. | RUN | | EASY |
| <i>RL</i> (RL) | REMOTE/LOCAL switch | LCL: Local mode REM: Remote mode (Displayed only in cases where the communication is specified.) | LCL | | |
| <i>AT</i> (AT) | AUTO-tuning switch | OFF: Disable 1 to 4: Perform auto-tuning. Tuning result is stored in the specified numbered PID. R: Tuning result is stored in the PID for reference deviation. | OFF | | |
| <i>SPNO</i> (SPNO.) | SP number selection | 1 to 4 (Depends on the setup parameter SPGR. setting.) | 1 | | |
| <i>PID</i> (PID) | PID number | The PID group number being selected is displayed. 1 to 4, R: PID group for reference deviation | 1 | | |

SELECT Parameter

Menu symbol: *CS* (CS)

| Parameter symbol | Name of Parameter | Setting Range | Initial value | User setting | Display level | | | | | |
|-----------------------------|---------------------------|--|---------------|--------------|---------------|------|------|------|------|------|
| Registered parameter symbol | SELECT parameter 10 to 19 | Setting range of a registered parameter. For details, see User's Manual (IM 05P01D31-01EN). | — | Table below | EASY | | | | | |
| Parameter CSn | n=10 | n=11 | n=12 | n=13 | n=14 | n=15 | n=16 | n=17 | n=18 | n=19 |

For the registration of SELECT parameters, see User's Manual (IM 05P01D31-01EN).

SP and Alarm Setpoint Setting Parameter

Menu symbol: *SP* (SP)

| Parameter symbol | Name of Parameter | Setting Range | Initial value | User setting | Display level |
|-------------------------------------|---|---|------------------------------|--------------|---------------|
| <i>SP</i> (SP) | Target setpoint | 0.0 to 100.0% of PV input range (EU) (Setting range: SPL to SPH) | SPL | Table below | EASY |
| <i>SUB</i> (SUB) | Sub-target setpoint (in Two-position two-level control) | Set the offset from SP. -100.0 to 100.0% of PV input range span (EUS) | 0.0 % of PV input range span | | |
| <i>PIDN</i> (PIDN) | PID number selection | Set a PID group number to use. 1 to 4 (Depends on the setup parameter PIDG. setting.) | 1 to 4 | | |
| <i>AL1</i> to <i>AL4</i> (A1 to A4) | Alarm-1 to -4 setpoint | Set a display value of setpoint of PV alarm, SP alarm, deviation alarm, output alarm, or velocity alarm. -19999 to 30000 (Set a value within the input range.) Decimal point position depends on the input type | 0 | | |

For the parameter SP (target setpoint), 4 groups are displayed for the factory default. The number of groups can be changed by the setup parameter SPGR. (number of SP groups). For the alarm setpoint parameter, alarm-1 to -4 are displayed for the factory default. The number of alarms can be changed using the setup parameter ALNO. (number of alarms). To change the number of SP groups or alarms, see User's Manual (IM 05P01D31-01EN).

Use the following table to record SP and alarm setpoints.

| Parameter | n=1 | n=2 | n=3 | n=4 |
|-----------|-----|-----|-----|-----|
| SP | | | | |
| SUB | | | | |
| PIDN | | | | |
| A1 | | | | |
| A2 | | | | |
| A3 | | | | |
| A4 | | | | |

n: group number

SP-related Setting Parameter

Menu symbol: *SPS* (SPS)

| Parameter symbol | Name of Parameter | Setting Range | Initial value | User setting | Display level |
|------------------|------------------------|---|------------------------------|--------------|---------------|
| <i>RT</i> (RT) | Remote input ratio | SP = Remote input x RT + Remote input bias 0.001 to 9.999 | 1.000 | STD | |
| <i>RBS</i> (RBS) | Remote input bias | -100.0 to 100.0% of PV input range span (EUS) | 0.0 % of PV input range span | | |
| <i>UPR</i> (UPR) | SP ramp-up rate | Used to prevent SP from changing suddenly. Set a ramp-up rate or ramp-down rate per hour or minute. Set a time unit using the parameter TMU. | OFF | EASY | |
| <i>DNR</i> (DNR) | SP ramp-down rate | OFF, 0.0 + 1 digit to 100.0% of PV input range span (EUS) | OFF | | |
| <i>TMU</i> (TMU) | SP ramp-rate time unit | HOUR: Ramp-up rate or ramp-down rate per hour MIN: Ramp-up rate or ramp-down rate per minute | HOUR | | |
| <i>SPT</i> (SPT) | SP tracking selection | Tracking is performed when the mode changes from Remote to Local. (The local setpoint keeps track of the remote setpoint.) OFF, ON | ON | | |
| <i>PVT</i> (PVT) | PV tracking selection | Causes the setpoint to keep track of the PV so the setpoint automatically reverts to its original value at a preset rate of change. The UPR, DNR, and TMU are used in combination. Operating conditions: 1) MAN → AUTO, 2) STOP → AUTO, 3) Power-on, 4) SP number change, 5) SP change OFF, ON | OFF | | STD |

Alarm Function Setting Parameter

Menu symbol: *ALRM* (ALRM)

| Parameter symbol | Name of Parameter | Setting Range | Initial value | User setting | Display level |
|---|--|---|---|--------------|---------------|
| <i>AL1</i> to <i>AL4</i> (AL1 to AL4) | Alarm-1 to 4 type Example: Alarm-1 AL1 00001 | Set a 5-digit value in the following [Latching action (0/1/2/3/4)] + [Energized (0) or De-energized (1)] + [Without (0) or With (1) Stand-by action] + [Alarm type: 2 digits (see below)] For latching action, see User's Manual (IM 05P01D31-01EN). Alarm type: 2 digits 00: Disable 01: PV high limit 02: PV low limit 03: SP high limit 04: SP low limit 05: Deviation high limit 06: Deviation low limit 07: Deviation high and low limits 08: Deviation within high and low limits 09: Target SP high limit 10: Target SP low limit 11: Target SP deviation high limit 12: Target SP deviation low limit 13: Target SP deviation high and low limits 14: Target SP deviation within high and low limits 15: OUT high limit 16: OUT low limit 17: Cooling-side OUT high limit 18: Cooling-side OUT low limit 19: Analog input PV high limit 20: Analog input PV low limit 27: Feedback input high limit 28: Feedback input low limit 29: PV velocity 30: Fault diagnosis 31: FAIL | AL1, AL3: Latching action (0) PV high limit (01) Without Stand-by action (0) Energized (0) AL2, AL4: Latching action (0) Energized (0) Without Stand-by action (0) PV low limit (02) | Table below | EASY |
| <i>VT1</i> to <i>VT4</i> (VT1 to VT4) | PV velocity alarm time setpoint 1 to 4 | 0.01 to 99.59 (minute.second) | 1.00 | | |
| <i>HY1</i> to <i>HY4</i> (HY1 to HY4) | Alarm-1 to -4 hysteresis | Set a display value of setpoint of hysteresis. -19999 to 30000 (Set a value within the input range.) Decimal point position depends on the input type. When the decimal point position for the input type is set to "1", the initial value of the hysteresis is "1.0". | 10 | | |
| <i>DYN1</i> to <i>DYN4</i> (DYN1 to DYN4) | Alarm-1 to -4 On-delay timer | An alarm output is ON when the delay timer expires after the alarm setpoint is reached. 0.00 to 99.59 (minute.second) | 0.00 | STD | |
| <i>AMD</i> (AMD) | Alarm mode | 0: Always active 1: Not active in STOP mode 2: Not active in STOP or MAN mode | 0 | | |

For the alarm function setting parameter, 4 alarms are displayed for the factory default. The number of alarms can be changed by the setup parameter ALNO. (number of alarms). To change the number of alarms, see User's Manual (IM 05P01D31-01EN).

| Parameter | n=1 | n=2 | n=3 | n=4 |
|-----------|-----|-----|-----|-----|
| ALn | | | | |
| VTn | | | | |
| HYn | | | | |
| DYNn | | | | |

n: alarm number

PV-related Setting Parameter

Menu symbol: *PVS* (PVS)

| Parameter symbol | Name of Parameter | Setting Range | Initial value | User setting | Display level |
|------------------|-------------------|---|------------------------------|--------------|---------------|
| <i>BS</i> (BS) | PV input bias | -100.0 to 100.0% of PV input range span (EUS) | 0.0 % of PV input range span | | EASY |
| <i>FL</i> (FL) | PV input filter | OFF, 1 to 120 s | OFF | | |

PID Setting Parameter

Menu symbol: *PID* (PID)

| Parameter symbol | Name of Parameter | Setting Range | Initial value | User setting | Display level |
|---------------------|--|---|---|--------------|---------------|
| <i>P</i> (P) | Proportional band | 0.0 to 999.9% When 0.0% is set, it operates as 0.1%. Heating-side ON/OFF control applies when 0.0% in Heating/cooling control | 5.0% | | EASY |
| <i>I</i> (I) | Integral time | Heating-side integral time (in Heating/cooling control) | 240 s | | |
| <i>D</i> (D) | Derivative time | Heating-side derivative time (in Heating/cooling control) | 60 s | | |
| <i>OH</i> (OH) | Control output high limit | Heating-side control output high limit (in Heating/cooling control) | -4.9 to 105.0%, (OL<OH) In Heating/cooling control: 0.1 to 105.0% (OL<OH) | 100.0% | |
| <i>OL</i> (OL) | Control output low limit | Heating-side control output low limit (in Heating/cooling control) | -5.0 to 104.9%, (OL<OH), SD: Tight shut In Heating/cooling control: 0.0 to 104.9% (OL<OH) | 0.0% | |
| <i>MR</i> (MR) | Manual reset | Manual reset value equals the output value when PV = SP. -5.0 to 105.0% | 50.0% | | |
| <i>HYS</i> (HYS) | Hysteresis (in ON/OFF control, Position proportional control, or Two-position two-level control) | In ON/OFF control or Two-position two-level control: 0.0 to 100.0% of PV input range span (EUS) In Heating/cooling control or Position proportional control: 0.0 to 100.0% | In ON/OFF control or Two-position two-level control: 0.5 % of PV input range span In Heating/cooling control or Position proportional control: 0.5 % | | |
| <i>SUHY</i> (SU.HY) | Sub-hysteresis (in Two-position two-level control) | | 0.5 % of PV input range span | | |
| <i>HYUP</i> (HY.UP) | Upper-side hysteresis (in ON/OFF control) | 0.0 to 100.0% of PV input range span (EUS) | 0.5 % of PV input range span | | |
| <i>HYLO</i> (HY.LO) | Lower-side hysteresis (in ON/OFF control) | | 0.5 % of PV input range span | | |
| <i>DR</i> (DR) | Direct/reverse action switch | RVS: Reverse action DIR: Direct action | RVS | STD | |
| <i>SUDR</i> (SU.DR) | Sub-direct/reverse action switch (in Two-position two-level control) | | DIR | | |
| <i>Pc</i> (Pc) | Cooling-side proportional band | 0.0 to 999.9% (Cooling-side ON/OFF control applies when 0.0% in Heating/cooling control) | 5.0% | | EASY |
| <i>Ic</i> (Ic) | Cooling-side integral time | OFF: Disable 1 to 6000 s | 240 s | | |
| <i>dc</i> (Dc) | Cooling-side derivative time | OFF: Disable 1 to 6000 s | 60 s | | |
| <i>OHc</i> (OHc) | Cooling-side control output high limit | 0.1 to 105.0%, (OLc<OHc) | 100.0% | | |
| <i>OLc</i> (OLc) | Cooling-side control output low limit | 0.0 to 104.9%, (OLc<OHc) | 0.0% | | |
| <i>HYSc</i> (HYSc) | Cooling-side ON/OFF control hysteresis | 0.0 to 100.0% | 0.5% | | |
| <i>db</i> (DB) | Output dead band (in Heating/cooling control or Position proportional control) | In Heating/cooling control: -100.0 to 50.0% In Position proportional control: 1.0 to 10.0% | 3.0% | | |
| <i>PO</i> (PO) | Preset output | Heating-side preset output (in Heating/cooling control) can be generated. In Position proportional control, Valve opening can be set; -5.0 to 105.0% | 0.0% | | |
| <i>SUPD</i> (SU.PO) | Sub-preset output (in Two-position two-level control) | In STOP mode, fixed sub-control output can be generated. 0%, 100% | 0% | | |
| <i>POc</i> (POc) | Cooling-side preset output | In STOP mode, cooling-side fixed control output can be generated. -5.0 to 105.0% | 0.0% | | |

For the PID setting parameter, 4 groups are displayed for the factory default. The number of groups can be changed by the setup parameter PIDG. (number of PID groups). To change the number of PID groups, see User's Manual (IM 05P01D31-01EN).

If you are using two or more groups of PID parameters, use the following table to record their setting values.

| Parameter | n=2 | n=3 | n=4 | R |
|------------------|-----|-----|-----|---|
| P | | | | |
| I | | | | |
| D | | | | |
| OH | | | | |
| OL | | | | |
| MR | | | | |
| HYS | | | | |
| SU.HY | | | | |
| HY.UP | | | | |
| HY.LO | | | | |
| DR | | | | |
| SU.DR | | | | |
| Pc | | | | |
| Ic | | | | |
| Dc | | | | |
| OHc | | | | |
| OLc | | | | |
| HYS _c | | | | |
| DB | | | | |
| PO | | | | |
| SU.PO | | | | |
| POc | | | | |

n: group number

Tuning Parameter

Menu symbol: **LUNE** (TUNE)

| Parameter symbol | Name of Parameter | Setting Range | Initial value | User setting | Display level |
|--|---|--|---------------|--------------|---------------|
| SC (SC) | Super function | OFF: Disable 1: Overshoot suppressing function (normal mode) 2: Hunting suppressing function (stable mode) Enables to answer the wider characteristic changes compared with response mode. 3: Hunting suppressing function (response mode) Enables quick follow-up and short converging time of PV for the changed SP. 4: Overshoot suppressing function (strong suppressing mode) Note: Setpoints 2 and 3 must be used in PID control or PI control. Disabled in the following controls: 1) ON/OFF control, 2) PD control, 3) P control, 4) Heating/cooling control. Do not use the function for the control processes with response such as flow or pressure control. | OFF | | EASY |
| | | | | | |
| AT.TY (AT.TY) | Auto-tuning type | 0: Normal 1: Stability | 0 | | STD |
| AR (AR) | Anti-reset windup (excess integration prevention) | AUTO, 50.0 to 200.0% | AUTO | | |
| OPR (OPR) | Output velocity limiter | OFF: Disable 0.1 to 100.0%/s | OFF | | |
| MPON (MPON) | Manual preset output number selection | Select the output used in MAN mode when switched from AUTO to MAN mode. OFF: Hold the control output in AUTO mode (bumpless) 1: Use manual preset output 1 (output bump) 2: Use manual preset output 2 (output bump) 3: Use manual preset output 3 (output bump) 4: Use manual preset output 4 (output bump) 5: Use manual preset output 5 (output bump) | OFF | | STD |
| | | | | | |
| MPD 1 to MPD5 (MPD1 to MPD5) | Manual preset output 1 to 5 | -5.0 to 105.0% However, output is limited to the output high limit and low limit. | 0.0% | Table below | |

Use the following table to record the manual preset output setting value.

| Parameter | n=1 | n=2 | n=3 | n=4 | n=5 |
|-----------|-----|-----|-----|-----|-----|
| MPOn | | | | | |

Zone Control Parameter

Menu symbol: **ZONE** (ZONE)

| Parameter symbol | Name of Parameter | Setting Range | Initial value | User setting | Display level |
|------------------------------------|-------------------------------|--|-----------------------------|--------------|---------------|
| RP 1 to RP3 (RP1 to RP3) | Reference point 1 to 3 | Set reference points at which switching is carried out between groups of PID constants according to the given temperature zone. 0.0 to 100.0% of PV input range (EU) (RP1 ≤ RP2 ≤ RP3) | 100.0% of PV input range | Table below | STD |
| RHY (RHY) | Zone PID switching hysteresis | Hysteresis can be set for switching at a reference point. 0.0 to 10.0% of PV input range span (EUS) | 0.5% of PV input range span | | |
| RDV (RDV) | Reference deviation | Set a deviation from SP. The PID for reference deviation is used if there is a larger deviation than the preset reference deviation. OFF: Disable 0.0 + 1 digit to 100.0% of PV input range span (EUS) | OFF | | |

For Zone control, set the setup parameter ZON (zone PID selection) to Zone PID selection.

Use the following table to record the reference point setting value.

| Parameter | n=1 | n=2 | n=3 |
|-----------|-----|-----|-----|
| RPn | | | |

P Parameter (for Ladder Program)

Menu symbol: **PPAR** (PPAR)

| Parameter symbol | Name of Parameter | Setting Range | Initial value | User setting | Display level | | | | | |
|-------------------------------------|----------------------|--|---------------|--------------|---------------|------|------|------|------|------|
| PO 1 to P 10 (P01 to P10) | P01 to P10 parameter | -19999 to 30000 (Set a decimal point position using LL50A Parameter Setting Software.) | 0 | Table below | STD | | | | | |
| Parameter | n=01 | n=02 | n=03 | n=04 | n=05 | n=06 | n=07 | n=08 | n=09 | n=10 |
| Pn | | | | | | | | | | |

Setup Parameters

Hold down the PARAMETER key or PARA key and Left arrow key simultaneously for 3 seconds to move from the Operation Display or Operation Parameter Setting Display to the Setup Parameter Setting Display.

Press the DISPLAY key or DISP key once to return to the Operation Display.

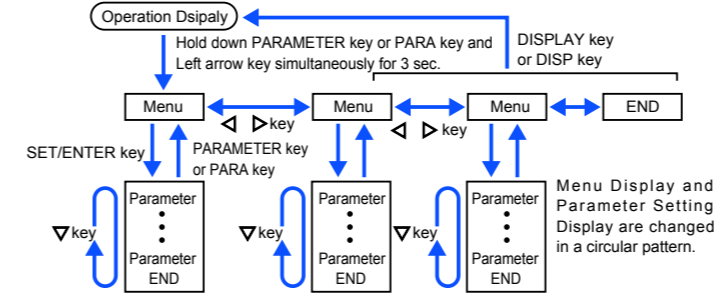

Move to the Operation Parameter Setting Display:
Hold down the PARAMETER key or PARA key for 3 sec.

Operation for Setting

- To select the parameter setting displayed as the initial value, press the Down arrow key to move to the next parameter.
- To change and set the parameter setting, press the SET/ENTER key to start the set-point blinking. The blinking state allows you to make changes (setting mode). Use the Up/Down/Left/Right arrow keys to change the setpoint. Press the SET/ENTER key to register the setting.

Note that there are some parameters which are not displayed depending on the Model and Suffix codes, control type (CNT), etc. The parameters for professional setting mode (LEVL: PRO) are not described in this manual. See User's Manual (IM 05P01D31-01EN).

Control Function Setting Parameter

Menu symbol: **CTL** (CTL)

| Parameter symbol | Name of Parameter | Setting Range | Initial value | User setting | Display level |
|-------------------------|----------------------|---|---------------------------------------|--------------|---------------|
| CNT (CNT) | Control type | PID: PID control ONOF: ON/OFF control (1 point of hysteresis) ONOF2: ON/OFF control (2 points of hysteresis) 2P2L: Two-position two-level control H/C: Heating/cooling control | PID or H/C (for Heating/Cooling type) | | EASY |
| SPGR (SPGR.) | Number of SP groups | Set a number of SP groups to use. 1 to 4 | 4 | | STD |
| ZON (ZON) | Zone PID selection | If set to "SP group number selection," allows PID constants to be selected for each SP group. If set to "Zone PID selection," automatically selects PID constants according to the range set in the Reference point. 0: SP group number selection 1 1: Zone PID selection (selection by PV) 2: Zone PID selection (selection by target SP) 3: SP group number selection 2 4: Zone PID selection (selection by SP) | 0 | | |
| PI dG (PIDG.) | Number of PID groups | Set a number of PID groups to use. 1 to 4 | 4 | | |

PV Input Setting Parameter

Menu symbol: **PV** (PV)

| Parameter symbol | Name of Parameter | Setting Range | Initial value | User setting | Display level |
|----------------------|---------------------------------------|---|-----------------------------|--------------|---------------|
| IN (IN) | PV input type | OFF: Disable K1: -270.0 to 1370.0 °C / -450.0 to 2500.0 °F K2: -270.0 to 1000.0 °C / -450.0 to 2300.0 °F K3: -200.0 to 500.0 °C / -200.0 to 1000.0 °F J: -200.0 to 1200.0 °C / -300.0 to 2300.0 °F T1: -270.0 to 400.0 °C / -450.0 to 750.0 °F T2: 0.0 to 400.0 °C / -200.0 to 750.0 °F B: 0.0 to 1800.0 °C / 32 to 3300 °F S: 0.0 to 1700.0 °C / 32 to 3100 °F R: 0.0 to 1700.0 °C / 32 to 3100 °F N: -200.0 to 1300.0 °C / -300.0 to 2400.0 °F E: -270.0 to 1000.0 °C / -450.0 to 1800.0 °F L: -200.0 to 900.0 °C / -300.0 to 1600.0 °F U1: -200.0 to 400.0 °C / -300.0 to 750.0 °F U2: 0.0 to 400.0 °C / -200.0 to 1000.0 °F W: 0.0 to 2300.0 °C / 32 to 4200 °F PL2: 0.0 to 1390.0 °C / 32.0 to 2500.0 °F P2040: 0.0 to 1900.0 °C / 32 to 3400 °F WRE: 0.0 to 2000.0 °C / 32 to 3600 °F JPT1: -200.0 to 500.0 °C / -300.0 to 1000.0 °F JPT2: -150.0 to 150.0 °C / -200.0 to 300.0 °F PT1: -200.0 to 850.0 °C / -300.0 to 1560.0 °F PT2: -200.0 to 500.0 °C / -300.0 to 1000.0 °F PT3: -150.0 to 150.0 °C / -200.0 to 300.0 °F 0.4-2V: 0.400 to 2.000 V 1-5V: 1.000 to 5.000 V 4-20: 4.00 to 20.00 mA 0-2V: 0.000 to 2.000 V 0-10V: 0.00 to 10.00 V 0-20: 0.00 to 20.00 mA -1020: -10.00 to 20.00 mV 0-100: 0.0 to 100.0 mV | OFF | | EASY |
| UNI (UNIT) | PV input unit | -: No unit, C: Degree Celsius -: No unit, -: No unit, -: No unit, F: Degree Fahrenheit | C | | STD |
| RH (RH) | Maximum value of PV input range | Depends on the input type. - For temperature input - Set the temperature range that is actually controlled. (RL<RH) - For voltage / current input - Set the range of a voltage / current signal that is applied. The scale across which the voltage/ current signal is actually controlled should be set using the maximum value of input scale (SH) and minimum value of input scale (SL). (Input is always 0% when RL = RH.) | Depends on the input type | | |
| RL (RL) | Minimum value of PV input range | Depends on the input type | Depends on the input type | | STD |
| SDP (SDP) | PV input scale decimal point position | 0: No decimal place 1: One decimal place 2: Two decimal places 3: Three decimal places 4: Four decimal places | Depends on the input type | | |
| SH (SH) | Maximum value of PV input scale | Depends on the input type | Depends on the input type | | STD |
| SL (SL) | Minimum value of PV input scale | -19999 to 30000, (SL<SH), SH - SL ≤ 30000 | Depends on the input type | | |
| BSL (BSL) | PV input burnout action | OFF: Disable UP: Upscale DOWN: Downscale | Depends on the input type | | STD |
| ABS (A.BS) | PV analog input bias | -100.0 to 100.0% of each input range span (EUS) | 0.0% of PV input range span | | |
| AFL (A.FL) | PV analog input filter | OFF, 1 to 120 s | OFF | | |

W: W-5% Re/W-26% Re(Hoskins Mfg.Co.). ASTM E988, WRE: W97Re3-W75Re25

Input Range, SP Limiter Setting Parameter

Menu symbol: **MPV** (MPV)

| Parameter symbol | Name of Parameter | Setting Range | Initial value | User setting | Display level |
|------------------------|---|---|---------------------------|--------------|---------------|
| PUNI (P.UNI) | Control PV input unit | -: No unit C: Degree Celsius -: No unit - -: No unit - -: No unit F: Degree Fahrenheit | Same as PV input unit | | STD |
| PDP (P.DP) | Control PV input decimal point position | 0: No decimal place 1: One decimal place 2: Two decimal places 3: Three decimal places 4: Four decimal places | Depends on the input type | | |
| PRH (P.RH) | Maximum value of control PV input range | Depends on the input type | Depends on the input type | | STD |
| PRL (P.RL) | Minimum value of control PV input range | -19999 to 30000, (P.RL<P.RH), P.RH - P.RL ≤ 30000 | Depends on the input type | | |
| SPH (SPH) | SP high limit | 100.0% of PV input range | 100.0% of PV input range | | STD |
| SPL (SPL) | SP low limit | 0.0 to 100.0% of PV input range (EU), (SPL<SPH) | 0.0% of PV input range | | |

■ Output Setting Parameter

Menu symbol: *OUE* (OUT)

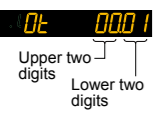
| Parameter symbol | Name of Parameter | Setting Range | Initial value | User setting | Display level |
|------------------------|--|--|---|--------------|---------------|
| <i>OL</i> (OT) | Output type selection  | Control output or Heating-side control output (Lower two digits) 00: OFF 01: OUT terminals (voltage pulse) 02: OUT terminals (current) 03: OUT terminals (relay) 06: OUT2 terminals (relay) 07: RET/OUT2 terminals (voltage pulse) 08: RET/OUT2 terminals (current) Cooling-side control output (Upper two digits) 00: OFF 01: OUT terminals (voltage pulse) 02: OUT terminals (current) 03: OUT terminals (relay) 06: OUT2 terminals (relay) 07: RET/OUT2 terminals (voltage pulse) 08: RET/OUT2 terminals (current) | Standard type: 00.03 Heating/cooling type: 06.03 | | EASY |
| <i>CT</i> (CT) | Control output cycle time Heating-side control output cycle time (in Heating/cooling control) | 0.5 to 1000.0 s | 30.0 s | | EASY |
| <i>CTC</i> (CTc) | Cooling-side control output cycle time | | 30.0 s | | |
| <i>VAT</i> (V.AT) | Automatic valve position adjustment | OFF: Stop automatic adjustment ON: Start automatic adjustment | OFF | | |
| <i>VRS</i> (V.RS) | Valve position setting reset | Setting V.RS to ON resets the valve adjustment settings and causes the indication "V.RS" to blink. | OFF | | |
| <i>VL</i> (V.L) | Fully-closed valve position setting | Pressing the SET/ENTER key with valve position set to the fully-closed position by Down arrow key causes the adjusted value to be stored. When V.L adjustment is complete, V.L stops blinking. | - | | |
| <i>VH</i> (V.H) | Fully-opened valve position setting | Pressing the SET/ENTER key with valve position set to the fully-opened position by Up arrow key causes the adjusted value to be stored. When V.H adjustment is complete, V.H stops blinking. | - | | |
| <i>TRT</i> (TR.T) | Valve traveling time | 5 to 300 s | 60 s | | |
| <i>VMOD</i> (V.MOD) | Valve adjusting mode | 0: Valve position feedback type 1: Valve position feedback type (moves to the estimating type if a feedback input error or break occurs.) 2: Valve position estimating type | 0 | | STD |
| <i>RTS</i> (RTS) | Retransmission output type of RET | OFF: Disable PV1: PV SP1: SP OUT1: OUT (Valve opening: 0 to 100 % in Position proportional control) LPS: 15 V DC loop power supply TSP1: Target SP HOUT1: Heating-side OUT COUT1: Cooling-side OUT MV1: Position proportional output (internal computed value) PV: PV terminals analog input | PV1 | | EASY |
| <i>RTH</i> (RTH) | Maximum value of retransmission output scale of RET | When RTS = PV1, SP1, TSP1, PV RTL + 1 digit to 30000 -19999 to RTH - 1 digit Decimal point position: When RTS=PV1, SP1, or TSP1, decimal point position is same as that of PV input. | 100 % of PV input range | | |
| <i>RTL</i> (RTL) | Minimum value of retransmission output scale of RET | When RTS=PV, decimal point position is same as that of PV input scale. | 0 % of PV input range | | |
| <i>O1RS</i> (O1RS) | Retransmission output type of OUT current output | Same as RTS | OFF | | |
| <i>O1RH</i> (O1RH) | Maximum value of retransmission output scale of OUT current output | When O1RS = PV1, SP1, TSP1, PV, O1RL + 1 digit to 30000 -19999 to O1RH - 1 digit Decimal point position: When O1RS=PV1, SP1, or TSP1, decimal point position is same as that of PV input. | - | | STD |
| <i>O1RL</i> (O1RL) | Minimum value of retransmission output scale of OUT current output | When O1RS=PV, decimal point position is same as that of PV input scale. | - | | |
| <i>OUA</i> (OU.A) | OUT current output range | 4-20: 4 to 20 mA 0-20: 0 to 20 mA | 4-20 | | |
| <i>RETA</i> (RET.A) | RET current output range | 20-4: 20 to 4 mA 20-0: 20 to 0 mA | 4-20 | | |

■ Heater Break Alarm Setting Parameter

Menu symbol: *HbA* (HBA)

| Parameter symbol | Name of Parameter | Setting Range | Initial value | User setting | Display level |
|------------------------|---|---|---------------|--------------|---------------|
| <i>Hb1S</i> (HB1.S) | Heater break alarm-1 function selection | 0: Heater current measurement 1: Heater break alarm (Heating-side) 2: Cooling-side heater break alarm | 1 | | |
| <i>Hb2S</i> (HB2.S) | Heater break alarm-2 function selection | | 1 | | |
| <i>Hb1</i> (HB1) | Heater break alarm-1 current setpoint | OFF, 0.1 to 300.0 Arms | OFF | | EASY |
| <i>Hb2</i> (HB2) | Heater break alarm-2 current setpoint | | OFF | | |
| <i>CT1</i> (CT1.T) | CT1 coil winding number ratio | 1 to 3300 | 800 | | |
| <i>CT2</i> (CT2.T) | CT2 coil winding number ratio | | 800 | | |
| <i>HDN1</i> (HDN1) | Heater break alarm-1 On-delay timer | 0.00 to 99.59 (m.s) | 0.00 | | STD |
| <i>HDN2</i> (HDN2) | Heater break alarm-2 On-delay timer | | 0.00 | | |

In cases where the current transformers manufactured by U.R.D. Co., Ltd are used, set the following value for the coil winding number ratio.
CTL-6-S-H: 800
CTL-12L-30: 3000

■ RS-485 Communication Setting Parameter (UT35A: E3-terminal Area, UT32A: E1-terminal Area)

Menu symbol: *R485* (R485)

| Parameter symbol | Name of Parameter | Setting Range | Initial value | User setting | Display level |
|---------------------|--------------------|--|---------------|--------------|---------------|
| <i>PSL</i> (PSL) | Protocol selection | PCL: PC link communication PCLSM: PC link communication (with checksum) LADR: Ladder communication CO-M: Coordinated master station CO-S: Coordinated slave station MBASC: Modbus (ASCII) MBRTU: Modbus (RTU) CO-S1: Coordinated slave station (Loop-1 mode) CO-S2: Coordinated slave station (Loop-2 mode) P-P: Peer-to-peer communication | MBRTU | | |
| <i>bPS</i> (BPS) | Baud rate | 600: 600 bps 1200: 1200 bps 2400: 2400 bps 4800: 4800 bps 9600: 9600 bps 19200: 19.2k bps 38400: 38.4k bps | 19200 | | EASY |
| <i>PRI</i> (PRI) | Parity | NONE: None EVEN: Even ODD: Odd | EVEN | | |
| <i>STP</i> (STP) | Stop bit | 1: 1 bit, 2: 2 bits | 1 | | |
| <i>DLN</i> (DLN) | Data length | 7: 7 bits, 8: 8 bits | 8 | | |
| <i>ADR</i> (ADR) | Address | 1 to 99 | 1 | | |

■ Ethernet Communication Setting Parameter (E3-terminal Area)

Menu symbol: *ETHR* (ETHR)

| Parameter symbol | Name of Parameter | Setting Range | Initial value | User setting | Display level |
|--|--|--|---------------|--------------|---------------|
| <i>HSR</i> (HSR) | High-speed response mode | OFF, 1 to 8 | 1 | | |
| <i>bPS</i> (BPS) | Baud rate | 9600: 9600 bps 19200: 19.2k bps 38400: 38.4k bps | 38400 | | |
| <i>PRI</i> (PRI) | Parity | NONE: None EVEN: Even ODD: Odd | EVEN | | |
| <i>IP1</i> to <i>IP4</i> (IP1 to IP4) | IP address 1 to 4 | 0 to 255 Initial value: (IP1),(IP2),(IP3),(IP4) = (192),(168),(1),(1) | See left | Table below | |
| <i>SM1</i> to <i>SM4</i> (SM1 to SM4) | Subnet mask 1 to 4 | 0 to 255 Initial value: (SM1),(SM2),(SM3),(SM4) = (255),(255),(255),(0) | See left | Table below | |
| <i>DG1</i> to <i>DG4</i> (DG1 to DG4) | Default gateway 1 to 4 | 0 to 255 Initial value: (DG1),(DG2),(DG3),(DG4) = (0),(0),(0),(0) | See left | Table below | EASY |
| <i>PRT</i> (PRT) | Port number | 502, 1024 to 65535 | 502 | | |
| <i>IPAR</i> (IPAR) | IP access restriction | OFF: Disable, ON: Enable | OFF | | |
| <i>IP1</i> to <i>IP4</i> (IP1 to IP4) | Permitted IP address 1-1 to 1-4 Permitted IP address 2-1 to 2-4 | 0 to 255 Initial value: (1.IP1),(1.IP2),(1.IP3),(1.IP4) = (255),(255),(255),(255) (2.IP1),(2.IP2),(2.IP3),(2.IP4) = (255),(255),(255),(255) | See left | Table below | |
| <i>ESW</i> (ESW) | Ethernet setting switch | Setting this parameter to "ON" enables the Ethernet communication parameter settings. OFF, ON | OFF | | |

Use the following table to record Ethernet communication setting value.

| Parameter | n=1 | n=2 | n=3 | n=4 |
|-----------|-----|-----|-----|-----|
| IPn | | | | |
| SMn | | | | |
| DGn | | | | |
| 1.IPn | | | | |
| 2.IPn | | | | |

■ PROFIBUS-DP Communication Setting Parameter (E3-terminal Area)

Menu symbol: *PROF* (PROF)

| Parameter symbol | Name of Parameter | Setting Range | Initial value | User setting | Display level |
|-----------------------|-------------------|--|---------------|--------------|---------------|
| <i>bR</i> (BR) | Baud rate | 9.6K: 9.6k bps 19.2K: 19.2k bps 93.75K: 93.75k bps 187.5K: 187.5k bps 0.5M: 0.5M bps 1.5M: 1.5M bps 3M: 3M bps 6M: 6M bps 12M: 12M bps AUTO 45.45K: 45.45k bps | AUTO | | EASY |
| <i>ADR</i> (ADR) | Address | 0 to 125 | 3 | | |
| <i>bPS</i> (BPS) | Baud rate | 9600: 9600 bps 19200: 19.2k bps 38400: 38.4k bps | 38400 | | |
| <i>FILE</i> (FILE) | Profile number | 0 to 3 | 0 | | |

■ DeviceNet Communication Setting Parameter (E3-terminal Area)

Menu symbol: *DNET* (DNET)

| Parameter symbol | Name of Parameter | Setting Range | Initial value | User setting | Display level |
|-----------------------|-------------------|--|---------------|--------------|---------------|
| <i>bR</i> (BR) | Baud rate | 125K: 125k bps 250K: 250k bps 500K: 500k bps | 125K | | |
| <i>ADR</i> (ADR) | Address | 0 to 63 | 63 | | EASY |
| <i>bPS</i> (BPS) | Baud rate | 9600: 9600 bps 19200: 19.2k bps 38400: 38.4k bps | 38400 | | |
| <i>FILE</i> (FILE) | Profile number | 0 to 3 | 0 | | |

■ CC-Link Communication Setting Parameter (UT35A: E3-terminal Area, UT32A: E1-terminal Area)

Menu symbol: *CC-L* (CC-L)

| Parameter symbol | Name of Parameter | Setting Range | Initial value | User setting | Display level |
|-----------------------|-------------------|--|---------------|--------------|---------------|
| <i>bR</i> (BR) | Baud rate | 156K: 156k bps 625K: 625k bps 2.5K: 2.5k bps 5M: 5M bps 10M: 10M bps | 10M | | |
| <i>ADR</i> (ADR) | Address | 1 to 64 | 1 | | EASY |
| <i>bPS</i> (BPS) | Baud rate | 9600: 9600 bps 19200: 19.2k bps 38400: 38.4k bps | 38400 | | |
| <i>FILE</i> (FILE) | Profile number | 0 to 3 and 6 (0, 1 and 6: Ver.1.10) (2 and 3: Ver.2.00) | 0 | | |

■ Key Action Setting Parameter

Menu symbol: *KEY* (KEY)

| Parameter symbol | Name of Parameter | Setting Range | Initial value | User setting | Display level |
|-------------------|------------------------------------|---|---------------|--------------|---------------|
| <i>F1</i> (F1) | User function key-1 action setting | OFF: Disable A/M: AUTO/MAN switch R/L1: REM/LCL switch S/R: STOP/RUN switch AUTO: Switch to AUTO MAN: Switch to MAN REM1: Switch to REM LCL1: Switch to LCL STOP: Switch to STOP RUN: Switch to RUN AT: Auto-tuning LTUP: LCD brightness UP LTDN: LCD brightness DOWN BRI: Adjust LCD brightness LCD: LCD backlight ON/OFF switch LAT: Latch release PID: PID tuning switch | OFF | | EASY |
| <i>F2</i> (F2) | User function key-2 action setting | | OFF | | |
| <i>FN</i> (Fn) | User function key-n action setting | | PID | | |

■ Display Function Setting Parameter

Menu symbol: *DISP* (DISP)

| Parameter symbol | Name of Parameter | Setting Range | Initial value | User setting | Display level |
|-----------------------|---|--|------------------------------|--------------|---------------|
| <i>PCMD</i> (PCMD) | Active color PV display switch | 0: Fixed in white 1: Fixed in red 2: Link to alarm 1 (Alarm OFF: white, Alarm ON: red) 3: Link to alarm 1 (Alarm OFF: red, Alarm ON: white) 4: Link to alarm 1 or 2 (Alarm OFF: white, Alarm ON: red) 5: Link to alarm 1 or 2 (Alarm OFF: red, Alarm ON: white) 6: PV limit (Within range: white, Out of range: red) 7: PV limit (Within range: red, Out of range: white) 8: SP deviation (Within deviation: white, Out of deviation: red) 9: SP deviation (Within deviation: red, Out of deviation: white) 10: Link to DI (ON: red, OFF: white) | 0 | | EASY |
| <i>PCH</i> (PCH) | PV color change high limit | Set a display value when in PV limit or SP deviation. -19999 to 30000 (Set a value within the input range.) | 0 | | |
| <i>PCL</i> (PCL) | PV color change low limit | Decimal point position depends on the input type. | 0 | | |
| <i>BAR1</i> (BAR1) | Bar-graph display registration | 0: Disable 1: OUT, Heating-side OUT, Internal value in Position proportional control 2: Cooling-side OUT 3: PV 4: SP 5: Deviation 6 to 16: Disable 17: Feedback input (valve opening) 18: PV terminals analog input 24: TSP 25: TSP deviation | 5 (Heating/cooling type: 1) | | |
| <i>BDV</i> (BDV) | Bar-graph deviation display band | 0.0 to 100.0% of PV input range span (EUS) | 1.0 % of PV input range span | | STD |
| <i>GUID</i> (GUID) | Guide display ON/OFF | OFF: Nondisplay, ON: Display | ON | | |
| <i>ECO</i> (ECO) | Economy mode | OFF: Disable 1: Economy mode ON (All indications except PV display OFF) 2: Economy mode ON (All indications OFF) 3: Brightness 10 % (whole indication) | OFF | | |
| <i>BRI</i> (BRI) | Brightness | (Dark) 1 to 5 (Bright) | 3 | | EASY |
| <i>MLSD</i> (MLSD) | Least significant digital mask of PV display | OFF: With least significant digit ON: Without least significant digit | OFF | | STD |
| <i>MKTP</i> (MKTP) | Method for least significant digital mask of PV display | 0: Rounding, 1: Rounding-off | 0 | | STD |

■ SELECT Display Setting Parameter

Menu symbol: *CSEL* (CSEL)

| Parameter symbol | Name of Parameter | Setting Range | Initial value | User setting | Display level |
|--|-------------------------------------|--|---------------|--------------|---------------|
| <i>CS1</i> to <i>CS5</i> (CS1 to CS5) | SELECT Display-1 to -5 registration | Register the operation parameter (except the Operation Mode) that is frequently modified to display it in the Operation Display. OFF, 2301 to 5000, 6701 to 6710 For the setting range, see Communication User's Manual. | OFF | Table below | STD |

Use the following table to record SELECT Display setting value.

| Parameter | n=1 | n=2 | n=3 | n=4 | n=5 |
|-----------|-----|-----|-----|-----|-----|
| CSn | | | | | |

■ Key Lock Setting Parameter

Menu symbol: *KLOC* (KLOC)

| Parameter symbol | Name of Parameter | Setting Range | Initial value | User setting | Display level |
|------------------------|---|--------------------------|---------------|--------------|---------------|
| <i>COMW</i> (COM.W) | Communication write enable/disable | OFF: Enable, ON: Disable | OFF | | STD |
| <i>DATA</i> (DATA) | Front panel parameter data (▼,▲) key lock | OFF: Unlock, ON: Lock | OFF | | |
| <i>A/M</i> (A/M) | Front panel A/M key lock | | OFF | | |

■ DI Function Registration Parameter

Menu symbol: *DI SL* (DI.SL)

| Parameter symbol | Name of Parameter | Setting Range | Initial value | User setting | Display level | |
|-------------------------|-------------------------------|---|--|--------------|---------------|--|
| <i>A/M</i> (A/M) | AUTO/MAN switch | Set an I relay number of contact input. Set "OFF" to disable the function. | 5025 | | STD | |
| <i>R/L</i> (R/L) | REMOTE/LOCAL switch | | OFF | | | |
| <i>S/R</i> (S/R) | STOP/RUN switch | | 5026 | | | |
| <i>AUTO</i> (AUTO) | Switch to AUTO | | OFF | | | |
| <i>MAN</i> (MAN) | Switch to MAN | | OFF | | | |
| <i>REM</i> (REM) | Switch to REMOTE | | Standard terminals DI1: 5025, DI2: 5026 | OFF | | |
| <i>LCL</i> (LCL) | Switch to LOCAL | | E1-terminal area DI11: 5041, DI12: 5042, DI13: 5043, DI14: 5044, DI15: 5045 | OFF | | |
| <i>AT</i> (AT) | Auto-tuning START/STOP switch | | OFF | | | |
| <i>LAT</i> (LAT) | Latch release | | OFF | | | |
| <i>LCD</i> (LCD) | LCD backlight ON/OFF switch | | OFF | | | |
| <i>PV/RW</i> (PV/RW) | PV red/white switch | OFF | | | | |

■ DI Function Numbering Parameter

Menu symbol: *DI NU* (DI.NU)

| Parameter symbol | Name of Parameter | Setting Range | Initial value | User setting | Display level |
|------------------------|--------------------------------------|---|--|--------------|---------------|
| <i>SPb0</i> (SP.B0) | Bit-0 of SP number | Set an I relay number of contact input. Set "OFF" to disable the function. | OFF | | EASY |
| <i>SPb1</i> (SP.B1) | Bit-1 of SP number | | OFF | | |
| <i>SPb2</i> (SP.B2) | Bit-2 of SP number | | OFF | | |
| <i>PNb0</i> (PN.B0) | Bit-0 of PID number | | Standard terminals DI1: 5025, DI2: 5026 | OFF | STD |
| <i>PNb1</i> (PN.B1) | Bit-1 of PID number | | Standard terminals DI1: 5025, DI2: 5026 | OFF | |
| <i>PNb2</i> (PN.B2) | Bit-2 of PID number | | E1-terminal area DI11: 5041, DI12: 5042, DI13: 5043, DI14: 5044, DI15: 5045 | OFF | |
| <i>MPb0</i> (MP.B0) | Bit-0 of manual preset output number | | | OFF | |
| <i>MPb1</i> (MP.B1) | Bit-1 of manual preset output number | | | OFF | |
| <i>MPb2</i> (MP.B2) | Bit-2 of manual preset output number | | | OFF | |
| <i>SPbC</i> (SP.BC) | Bit changing method of SP number | | 0: Status switch 1 1: Status switch 2 | 0 | |

■ AL1-AL3 Function Registration Parameter

Menu symbol: *ALM* (ALM)

| Parameter symbol | Name of Parameter | Setting Range | Initial value | User setting | Display level |
|------------------------|-------------------------------|---|---------------|--------------|---------------|
| <i>AL15</i> (AL1.S) | AL1 function selection | Set an I relay number. For the items other than below, see Communication User's Manual. Ex.) Set the number 4353 for AL1.S to use the alarm 1. Set "OFF" to disable the function. | 4353 | | STD |
| <i>AL25</i> (AL2.S) | AL2 function selection | No function: OFF Alarm 1: 4353 Alarm 2: 4354 Alarm 3: 4355 Alarm 4: 4357 | 4354 | | |
| <i>AL35</i> (AL3.S) | AL3 function selection | | 4355 | | |
| <i>OR.S</i> (OR.S) | OUT relay function selection | AUTO (OFF) / MAN (ON) status: 4193 REM (ON) / LCL (OFF) status: 4194 STOP (ON) / RUN (OFF) status: 4195 FAIL (Normally ON) output: 4256 | OFF | | |
| <i>OR2S</i> (OR2.S) | OUT2 relay function selection | | OFF | | |

■ DO Setting Parameter (E1/E4-terminal Area)

Menu symbol: *DO* (DO)

| Parameter symbol | Name of Parameter | Setting Range | Initial value | User setting | Display level |
|------------------------|------------------------------|--|---------------|--------------|---------------|
| <i>DO15</i> (DO1.S) | DO11/DO41 function selection | Same as AL1.S Set "OFF" to disable the function | OFF | Table below | STD |
| <i>DO25</i> (DO2.S) | DO12/DO42 function selection | | OFF | | |
| <i>DO35</i> (DO3.S) | DO43 function selection | | OFF | | |
| <i>DO45</i> (DO4.S) | DO44 function selection | | OFF | | |
| <i>DO55</i> (DO5.S) | DO45 function selection | | OFF | | |

Use the following table to record DO setting value.

| Parameter | E1-terminal Area | E4-terminal Area |
|-----------|------------------|------------------|
| DO1.S | | |
| DO2.S | | |
| DO3.S | | |
| DO4.S | | |
| DO5.S | | |

■ System Setting Parameter

Menu symbol: *SYS* (SYS)

| Parameter symbol | Name of Parameter | Setting Range | Initial value | User setting | Display level |
|-----------------------|---------------------------|--|---------------------------------------|--------------|---------------|
| <i>RMD</i> (R.MD) | Restart mode | Set how the controller should recover from a power failure of 5 seconds or more. CONT: Continue action set before power failure. MAN: Start from MAN. AUTO: Start from AUTO. | CONT | | STD |
| <i>RTM</i> (R.TM) | Restart timer | Set time between power on and the instant where controller starts computation. 0 to 10 s | 0 | | |
| <i>EPO</i> (EPO) | Input error preset output | Set preset output value when the input burnout or ADC error occurs. Manual output is prioritized when the input burnout occurs in MAN. 0: Preset output 1: 0% output 2: 100% output | 0 | | |
| <i>FREQ</i> (FREQ) | Power frequency | AUTO, 60: 60 Hz, 50: 50 Hz | AUTO | | EASY |
| <i>QSM</i> (QSM) | Quick setting mode | OFF: Disable ON: Enable | ON | | |
| <i>LANG</i> (LANG) | Guide display language | ENG: English FRA: French GER: German SPA: Spanish | Depends on the model and suffix codes | | |
| <i>PASS</i> (PASS) | Password setting | 0 (No password) to 65535 | 0 | | |

■ Error and Version Confirmation Parameter (for display only)

Menu symbol: *VER* (VER)

| Parameter symbol | Name of Parameter | Status record | Display level |
|------------------------|----------------------------------|---------------|---------------|
| <i>PRER</i> (PA.ER) | Parameter error status | | EASY |
| <i>OPER</i> (OP.ER) | Option error status | | |
| <i>AD1E</i> (AD1.E) | A/D converter error status 1 | | |
| <i>AD2E</i> (AD2.E) | A/D converter error status 2 | | |
| <i>PV1E</i> (PV1.E) | PV input error status | | |
| <i>LAER</i> (LA.ER) | Ladder error status | | |
| <i>MCU</i> (MCU) | MCU version | | |
| <i>DCU</i> (DCU) | DCU version | | |
| <i>ECU1</i> (ECU1) | ECU-1 version (E1-terminal area) | | |
| <i>ECU3</i> (ECU3) | ECU-3 version (E3-terminal area) | | |
| <i>ECU4</i> (ECU4) | ECU-4 version (E4-terminal area) | | |
| <i>PARA</i> (PARA) | Parameter version | | |
| <i>HVER</i> (H.VER) | Product version | | |
| <i>SER1</i> (SER1) | Serial number 1 | | |
| <i>SER2</i> (SER2) | Serial number 2 | | |
| <i>MAC1</i> (MAC1) | MAC address 1 (E3-terminal area) | | |
| <i>MAC2</i> (MAC2) | MAC address 2 (E3-terminal area) | | |
| <i>MAC3</i> (MAC3) | MAC address 3 (E3-terminal area) | | |

■ Parameter Display Level Parameter

Menu symbol: *LVL* (LVL)

| Parameter symbol | Name of Parameter | Setting Range | Initial value | User setting | Display level |
|-------------------------|-------------------------|---|---------------|--------------|---------------|
| <i>LEV L</i> (LEV.L) | Parameter display level | EASY: Easy setting mode STD: Standard setting mode PRO: Professional setting mode | STD | | EASY |

* For Professional setting mode, see User's Manual.

- Authorised Representative in the EEA
Yokogawa Europe BV. (Address: Euroweg 2 , 3825 HD Amersfoort, The Netherlands) is the Authorised Representative of Yokogawa Electric Corporation for this Product in the EEA.
- Printed Manuals

| Model | Description |
|---|------------------|
| UT35A, UT32A Digital Indicating Controller (Panel Mounting Type) Operation Guide «Standard Code Model» | IM 05P01D31-11EN |
| UT35A, UT32A Digital Indicating Controller (Panel Mounting Type) Operation Guide «Detailed Code Model» | IM 05P01D31-15EN |
| UT35A/MDL, UT32A/MDL Digital Indicating Controller (DIN Rail Mounting Type) Operation Guide «Standard Code Model» | IM 05P01D81-11EN |
| UT32A-D Digital Indicating Controller (Dual-loop, Panel Mounting Type) Operation Guide «Standard Code Model» | IM 05P08D31-11EN |
| UT32A-D/MDL Digital Indicating Controller (Dual-loop, DIN Rail Mounting Type) Operation Guide «Standard Code Model» | IM 05P08D81-11EN |
| UT35A/RSP, UT32A/RSP Digital Indicating Controller (Non-isolated Remote Input Type) Operation Guide «Standard Code Model» | IM 05P01D31-81EN |
| UT32A Digital Indicating Controller Operation Guide «Entry model» | IM 05P01F31-11EN |
| Precautions on the Use of the UTAdvanced Series | IM 05P01A01-11EN |

- Electronic Manuals
You can download the latest manuals from the following website:
URL: <http://www.yokogawa.com/ns/ut/im/>

| Model | Description |
|---|------------------|
| UT35A, UT32A Digital Indicating Controller (Panel Mounting Type) Operation Guide «Standard Code Model» | IM 05P01D31-11EN |
| UT35A, UT32A Digital Indicating Controller (Panel Mounting Type) Operation Guide «Detailed Code Model» | IM 05P01D31-15EN |
| UT35A/MDL, UT32A/MDL Digital Indicating Controller (DIN Rail Mounting Type) Operation Guide «Standard Code Model» | IM 05P01D81-11EN |
| UT35A/UT32A Digital Indicating Controller User's Manual | IM 05P01D31-01EN |
| UT32A-D Digital Indicating Controller (Dual-loop, Panel Mounting Type) Operation Guide «Standard Code Model» | IM 05P08D31-11EN |
| UT32A-D/MDL Digital Indicating Controller (Dual-loop, DIN Rail Mounting Type) Operation Guide «Standard Code Model» | IM 05P08D81-11EN |
| UT32A-D, UT32A-D/MDL Digital Indicating Controller Controller User's Manual | IM 05P08D31-01EN |
| UT35A/RSP, UT32A/RSP Digital Indicating Controller (Non-isolated Remote Input, Panel Mounting Type) Operation Guide «Standard Code Model» | IM 05P01D31-81EN |
| UT32A Digital Indicating Controller Operation Guide «Entry Model» | IM 05P01F31-11EN |
| UT32A Digital Indicating Controller User's Manual «Entry Model» | IM 05P01F31-01EN |
| UTAdvanced Series Communication Interface (RS-485, Ethernet) User's Manual | IM 05P07A01-01EN |
| UTAdvanced Series Communication Interface (Open Network) User's Manual | IM 05P07A01-02EN |
| LL50A Parameter Setting Software Installation Manual | IM 05P05A01-01EN |
| LL50A Parameter Setting Software User's Manual | IM 05P05A01-02EN |
| Precautions on the Use of the UTAdvanced Series | IM 05P01A01-11EN |

- General Specification

| Model | Description |
|---|------------------|
| UT35A, UT32A Digital Indicating Controller (Panel Mounting Type) | GS 05P01D31-01EN |
| UT35A/MDL, UT32A/MDL Digital Indicating Controller (DIN Rail Mounting Type) | GS 05P01D81-01EN |
| UT32A-D Digital Indicating Controller (Dual-loop, Panel Mounting Type) | GS 05P08D31-01EN |
| UT32A-D/MDL Digital Indicating Controller (Dual-loop, DIN Rail Mounting Type) | GS 05P08D81-01EN |
| LL50A Parameter Setting Software | GS 05P05A01-01EN |

- * The last two characters of the manual number and general specification number indicate the language in which the manual is written.

Trademarks

- Our product names or brand names mentioned in this manual are the trademarks or registered trademarks of Yokogawa Electric Corporation.
- Adobe, Acrobat, and Postscript are either registered trademarks or trademarks of Adobe Systems Incorporated.
- Ethernet is a registered trademark of XEROX Corporation in the United States.
- Modbus is a registered trademark of Schneider Electric.
- PROFIBUS-DP is a registered trademark of PROFIBUS User Organization.
- DeviceNet is a registered trademark of Open DeviceNet Vendor Association.
- CC-Link is a registered trademark of CC-Link Partner Association.
- We do not use the TM or ® mark to indicate these trademarks or registered trademarks in this manual.
- All other product names mentioned in this manual are trademarks or registered trademarks of their respective companies.