

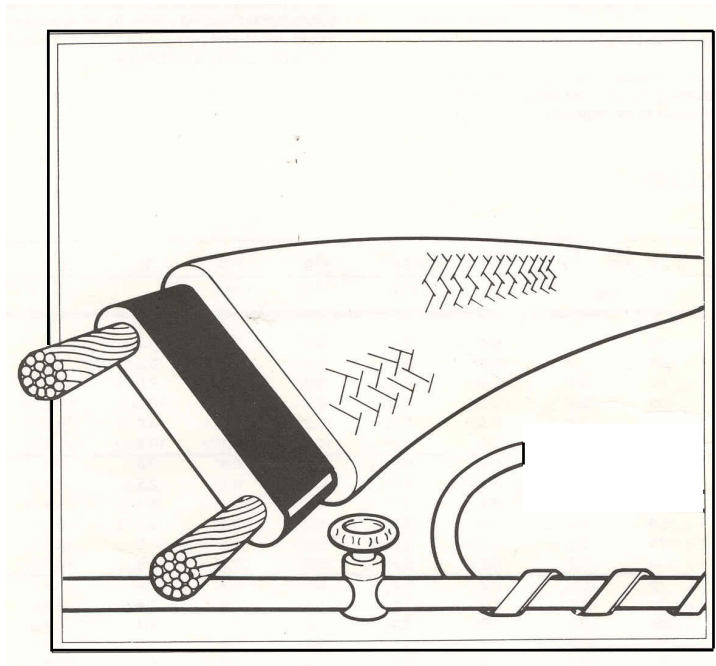

# Self-Regulating Heating Cables

## INSTALLATION INSTRUCTIONS



WinterSafe  
WinterSafe Plus  
AutoWatt Xtra

### **WARNING**

All electric heat tracing systems must be installed correctly to ensure safe, proper operation and to prevent shock and fire. Read and follow these instructions carefully.

- To minimize the danger of fire from sustained electrical arcing if the heating cable is damaged or improperly installed, use a ground-fault protection device (GFPD). Arcing may not be stopped by conventional style circuit breakers.

The 2002 National Electric Code, Sections 426 and 427 require the use of ground-fault equipment protection on heating cable installations. Consult the last section of this document (labeled *Ground-Fault Protection*) for the recommended circuit breakers to use with all self-regulating cables supplied by HTD.

- Failure to properly install the correct component kits can cause arcing and fire. Do not use other kits or substitute parts. Do not use vinyl electrical tape. Use only the specified HTD termination and connection kits and follow the installation instructions supplied with them.
  - Damaged heating cable or components can cause electrical shock, arcing and fire. Do not attempt to repair or energize damaged heating cable. Remove damaged sections at once and replace them with a new length of heating cable using the appropriate HTD splice kit. Replace damaged components.
  - The black heating cable core within all styles of self-regulating heating cable supplied by HTD is electrically conductive and can short. The heating cable core must be properly insulated and kept dry.
  - Damaged bus wires can overheat or short. Do not break bus wire strands when stripping the heating cable.
  - Do not use metal attachments such as pipe straps or tie wires. Use only HTD approved tapes and cable ties to secure the heating cables to the pipe.
- 

### **INTRODUCTION**

These instructions cover the installation requirements for WinterSafe, WinterSafe Plus and AutoWatt Xtra self-regulating heating cables as supplied by HTD Heat Trace, Inc.

The instructions assume that the proper heat tracing design has been completed according to the HTD *Thermal Design Guide*.

Use the proper HTD self-regulating heating cable for the specific application as shown in the HTD *Heating Cable Selection Guide* and *Heating Cable Selection Matrix*

---

### **ELECTRICAL CODES**

Sections 426, 427 and 500 of the 2002 National Electrical Code (NEC) and Part 1 of the Canadian Electrical Code Sections 18 and 62 govern the installation of electrical heat tracing systems. All heat tracing system installations must be in compliance with these and any other national, state, provincial or local codes.

### *HEATING CABLE STORAGE*

Store all heating cables and components in a clean dry place.

Store all heating cables and components at temperatures between -40°F and 140°F (-40°C and 60°C).

Do not store heating cables and components in high traffic areas where potential damage may occur.

---

### *PREINSTALLATION CHECKS*

Check the materials received.

- Check the heating cable catalog number and quantity received against the Purchase Order or Bill of Materials. The heating cable catalog number is printed directly on the outside of the heating cable jacket.
- Verify that the correct components and quantities are present for use with the selected heating cable.
- Inspect the heating cable and components for any damage that may have occurred during transit.

Check the pipe to be heat traced.

- Verify that the pipe has been pressure-tested and that all equipment and supports are installed.
- Verify that any paint or coatings used on the pipe are dry.
- Walk the piping system and plan the routing of the heating cable on the pipe.
- Remove any sharp edges or burrs that could damage the heating cable.

Plan the installation. Compare the design drawings or sketches with the actual pipe and note any differences in:

- Pipe length and size.
- The number of valves, flanges, gauges, and other equipment.
- The number of pipe supports. These items are frequently not shown on drawings but there should be some form of notation on the drawing to indicate the amount of heating cable that is included in the circuit for the pipe supports.

Identify the location of the heating cable terminations.

- Mark the location of all power connections, splices, tee splices and end terminations on the pipe using a vivid color spray paint or marker.

**HEATING CABLE  
INSTALLATION**

Pay out heating cable (see Figure 1).

- Mount the cable spool on a holder near either end of the pipe to be traced. Do not apply excessive pulling or jerking on the cable as it is being unrolled.
- Pay out the heating cable and loosely string it along the pipe. Make sure that the cable is always next to the pipe when crossing obstacles. If the cable is on the wrong side of the obstacle (eg. a support beam, crossing pipe etc) it may have to be removed and reinstalled or cut and spliced.
- For installations that require two or more heating cables, use two or more holders to pay out the cables, essentially replicating the procedure shown in Figure 1.

Figure 1

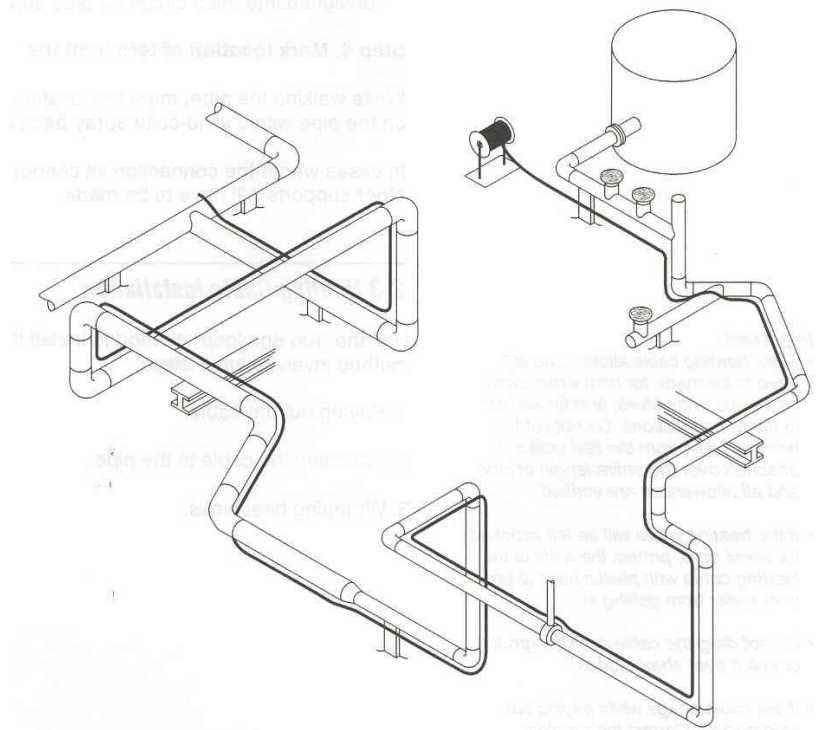

- Alternatively, for installations that require two heating cables, use one holder, secure the end of the cable to the pipe and pull one large loop as shown in Figure 2.

Figure 2

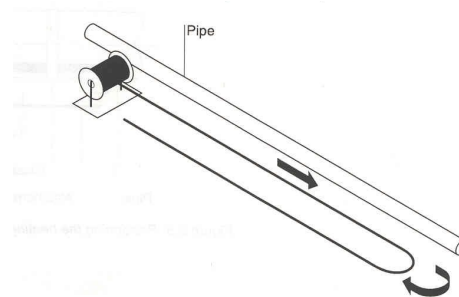

### ATTACHING THE HEATING CABLE

The heating cable may be straight traced along the pipe, spiral wrapped around the pipe or straight traced in multiple runs along the pipe, as required by the design.

#### Straight tracing along the pipe

- Whenever possible, position the heating cable or cables on the lower section of pipe as shown in Figure 3. This helps to protect the heating cable from mechanical damage during the installation, pre-insulation and insulation phases of the project.

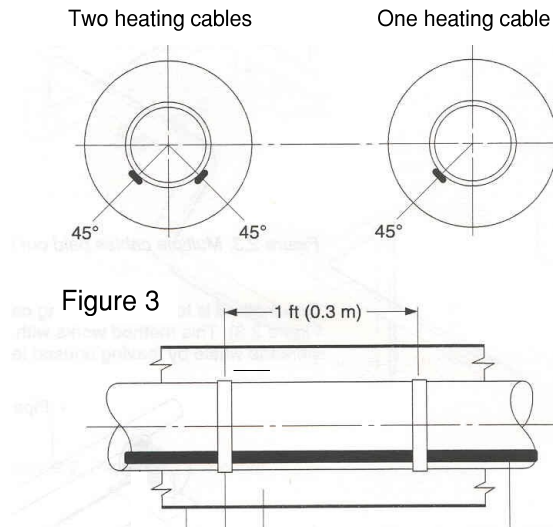

### FIXING / TYING TAPES

Use type VTFGT adhesive backed glass tape on all WSR cable installations. This product may also be used on all WSP and AWX cable installations when the highest exposure and/or operating temperature of the application is below 310°F (155°C). VTFGT glass tape may be used in low ambient temperatures down to -40°F (-40°C).

- Use type PGT glass tape on all WSP and AWX cable installations when the maximum exposure and/or operating temperature of the application is above 310°F (155°C).
- Type IAAT3 adhesive backed aluminum heat transfer tape is recommended as a heat-transfer aid for wrapping heat traced pump bodies, valves and other odd-shaped devices on applications up to 200°F (93°C). This product should also be applied over the entire length of heating cable when the pipe being heat traced is non metallic (eg, PVC, FRP, Polyethylene, etc). IAAT3 tape must be applied when ambient temperatures are above 32°F (0°C)
- Cable ties may be used to secure the heating cable to the pipe on installations below 180°F (82°C) when the surface of the pipe prevents proper adhesion of the VTFGT tape. Cable ties must be hand-tightened only.

## INSTALLATION INSTRUCTIONS

### SECURING THE HEATING CABLE

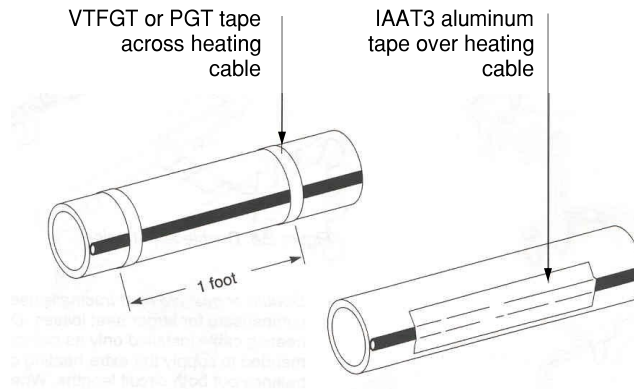

### ATTACHING THE HEATING CABLE (cont)

- Starting from the end opposite to the cable spool and holder, secure the heating cable to the pipe using wraps of glass tape at 1 foot intervals as shown in Figure 3. If type IAAT3 aluminum tape is being used, apply it longitudinally over the entire length of heating cable after the cable has first been secured with glass tape.
- Work back towards the cable spool and holder, repeating the above procedure.
- Leave an extra 18" (0.48m) of heating cable at the power connection, at all sides of splices and tee splices and at the end seal location to provide sufficient cable to complete the required terminations.
- Extra heating cable must be allowed and pulled for each heat sink (flange, pipe support, valve, instrument etc). The extra heating cable should be taped immediately before and after the heat sink and left in a loop as shown in Figure 4. To obtain the required loop length for the type of heat sink being traced, consult the design drawing or the HTD Thermal Design Guide.

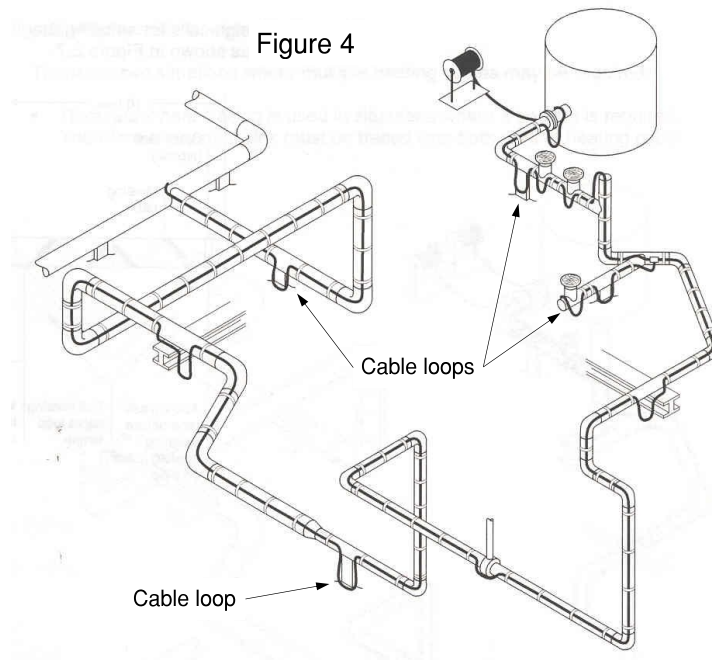

**ATTACHING THE HEATING CABLE (cont)**

**Spiral tracing of pipe**

- When the design calls for spiral tracing or wrapping of the heating cable on the pipe, begin by suspending a loop of heating cable for every 10 ft (3.04m) section of pipe as shown in Figure 5.

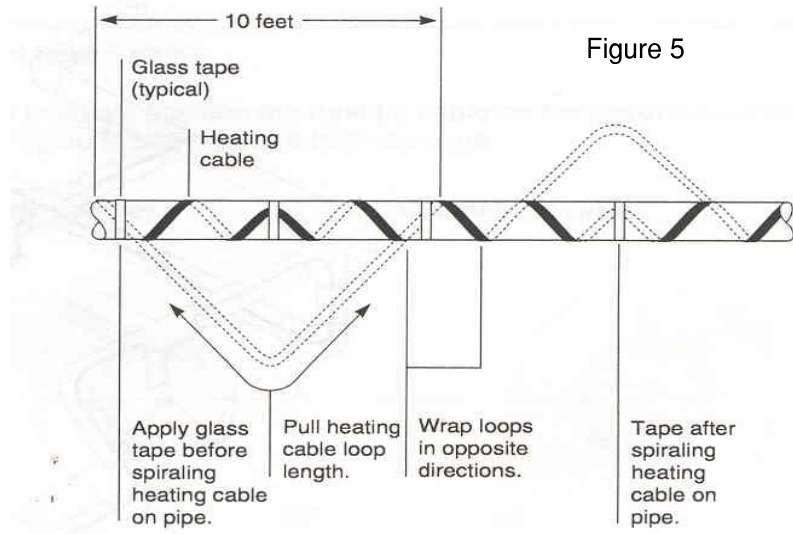

- To determine the loop length, multiply the spiral factor from the drawing by ten (eg if the spiral factor is 1.3, leave a 13ft loop of heating cable for every 10ft of pipe).
- Pull the required amount of heating cable for the 10ft section of pipe, attach the cable to the pipe at each end and let it hang in a loop. Grasp the loop in the center and wrap it around the pipe. Even out the distances between each spiral by sliding the wraps along the pipe. Use glass tape to secure the center of the loop to the pipe. Ensure that the heating cable is flat to the pipe for good heat transfer.

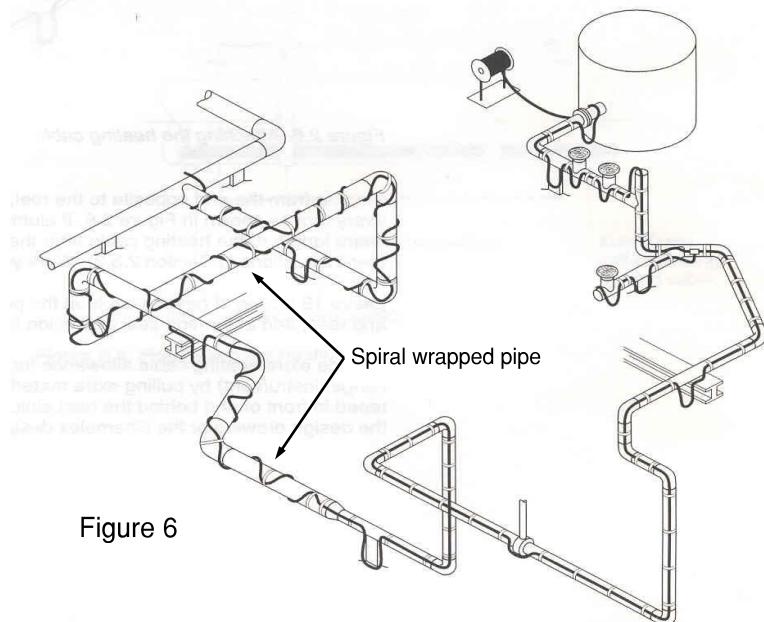

Figure 6

## INSTALLATION INSTRUCTIONS

### ATTACHING THE HEATING CABLE (cont)

#### Double or Multiple tracing runs

There are two design situations that dictate the use of two or more runs of cable on the pipe. These are:

- Critical processes sometimes require redundant heating circuits. In this type of design, heat sinks must be traced with both runs of cable.
- Double or multiple runs of heating cable may be required to compensate for high heat losses that cannot be offset by the use of one cable. When using two or more spools of cable to supply runs to one pipe, it is important to take the extra cable required for tracing heat sinks from alternate spools. This will help to equalize the heating cable lengths in each circuit. Access loops should also be left on each heat sink that may require future service or maintenance.

### CABLE ROUTING ON TYPICAL HEAT SINKS

The cable attachment portion of the installation is completed by wrapping each of the loops shown in Figure 4 onto the heat sink. Route the cable path of each loop as shown in the following drawings.

#### Flange

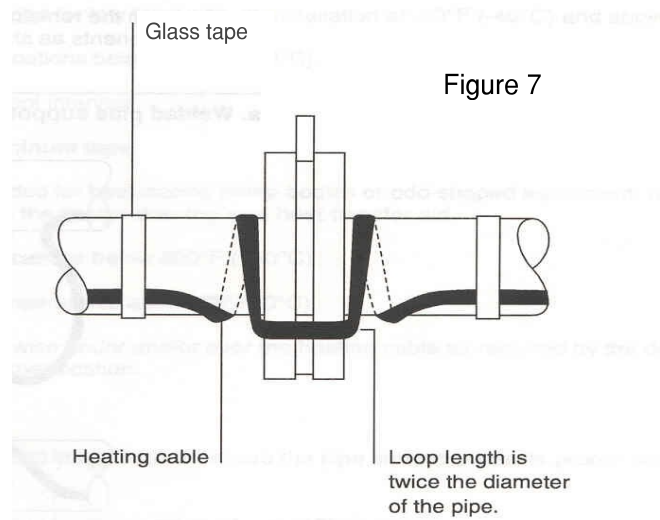

#### Elbow

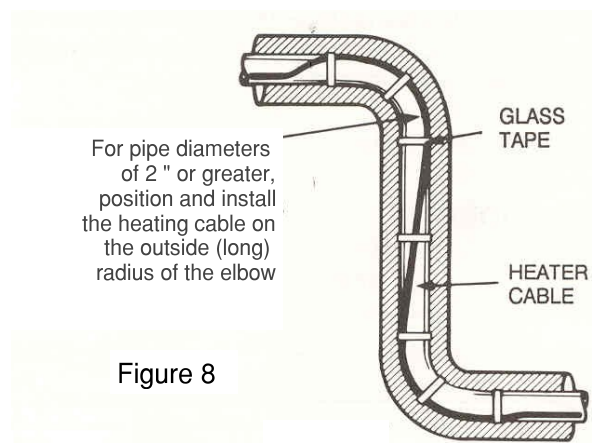



*CABLE ROUTING  
ON TYPICAL  
HEAT SINKS (cont)*

**Welded pipe support**

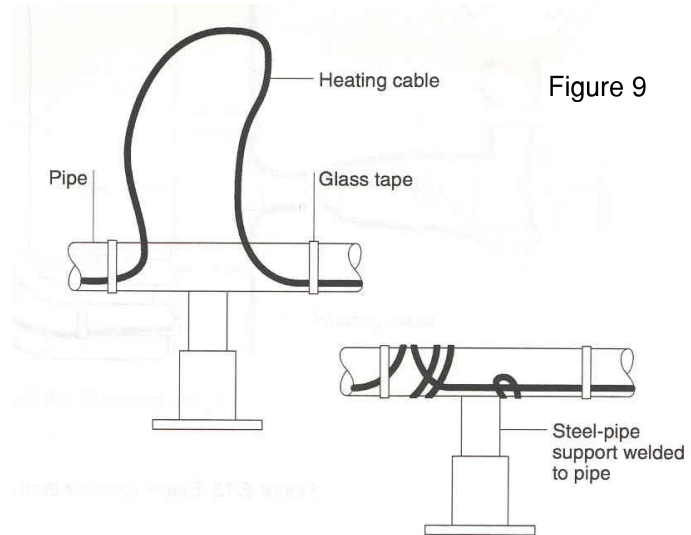

**Welded Pipe Support with Shoe**

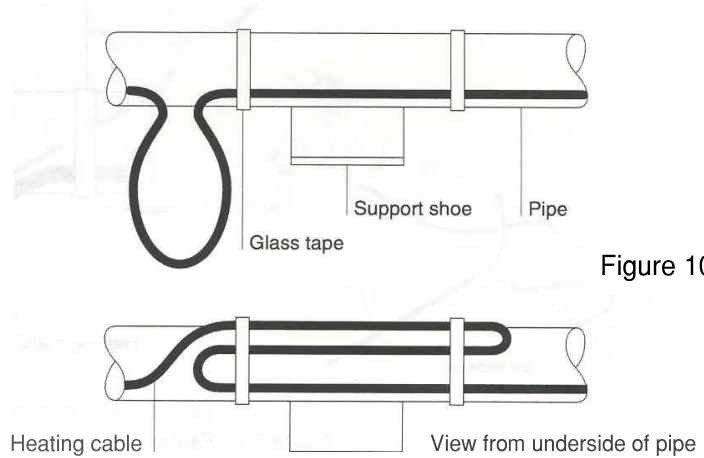

**Valve (typical)**

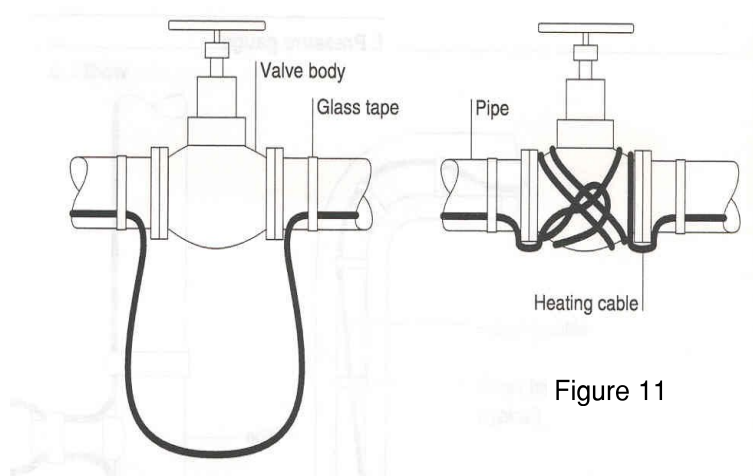

*CABLE ROUTING  
ON TYPICAL  
HEAT SINKS (cont)*

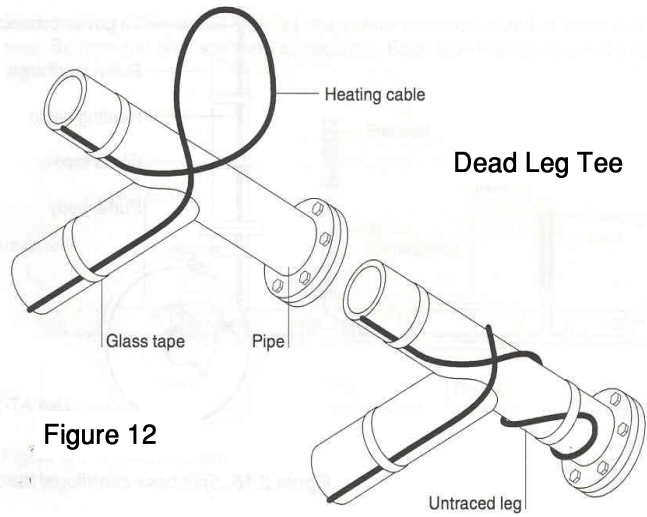

Figure 12

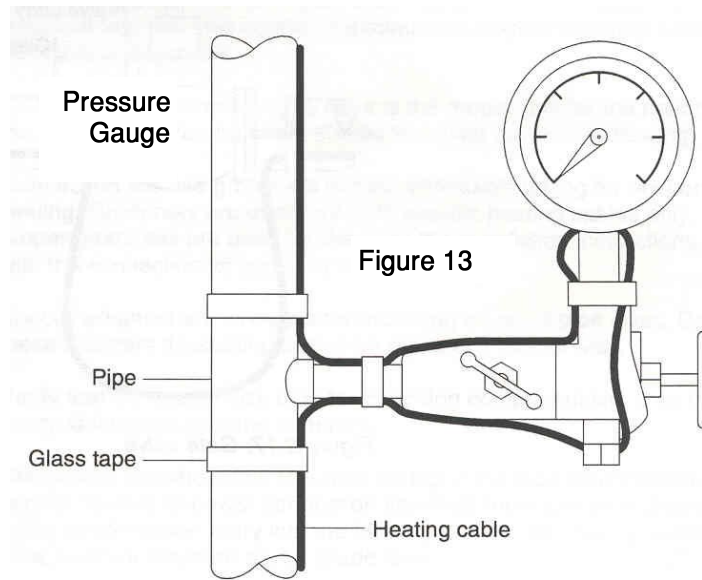

Figure 13

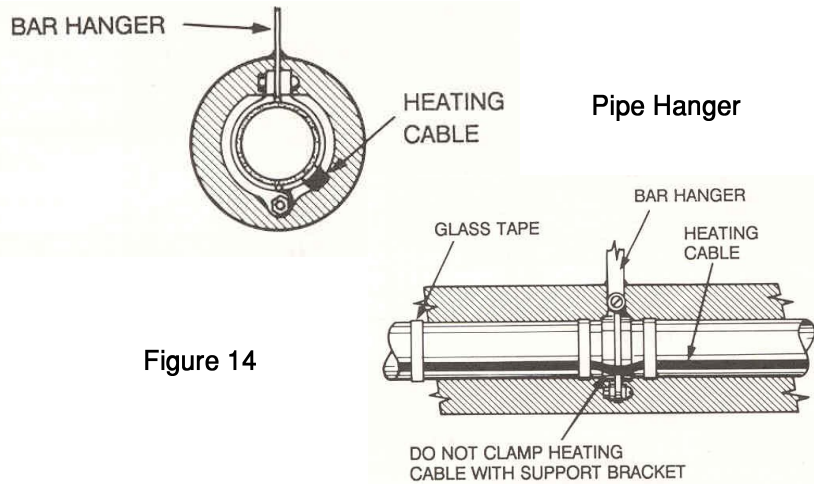

Figure 14

### *SYSTEM COMPONENTS*

Detailed installation instructions are supplied with each kit. Follow these instructions carefully when installing each kit.

Before installing any kits, please consider the following important points:

- The black heating cable core is an electrically conductive heating matrix and can short. It must be properly insulated and kept dry.
- Damaged bus wires can overheat or short. Do not break bus wire strands when stripping the heating cable.
- Never connect or twist the heating cable bus wires together. This will cause a short.
- Failure to properly install the correct component kits can cause arcing and fire. Do not use other kits or substitute parts. Do not use vinyl electrical tape. Use only the specified HTD termination and connection kits.
- Termination and connection kits should be positioned on top of the pipe when practical. Electrical conduit leading to power connection kits must have low-point drains installed to avoid condensation entry into the heating system. All heating cable connections must be mounted above grade.

**TESTING**

Following the correct installation of the required kits, and before the pipe is insulated, it is important to apply an Insulation Resistance (IR) test to each heating circuit. Insulation Resistance testing is a reliable indicator of the electrical integrity of the heating circuit when all of the installation instructions are properly followed. Insulation Resistance Testing is more commonly known as "meggering". The following test must be completed on each heating circuit.

- As per ANSI IEEE Standard 141-1986, megger testing should be done at 500, 1,000 and 2,500 Vdc. Significant problems may not be detected if testing is only done at 500 or 1,000 volts.
- The megger test for braided versions of heating cable should be conducted between the heating cable bus wires and the heating cable braid.
- The megger test for braided and overjacketed versions of heating cable requires the above test plus a second megger test taken between the heating cable braid and the pipe.

All Insulation Resistance values should be greater than 1,000 megohms.

Apply thermal insulation to pipe and *repeat above tests*

**GROUND-FAULT  
PROTECTION**

NEC Article 427-22 requires ground fault protection on all heating cable systems. Additionally, IEEE Std 515-1997 recommends the use of ground fault breakers with a 30-mA trip level.

To comply with these requirements and reduce the risk of fire caused by damage or improper installation, HTD recommends the use of Square D QO-EPD and QOB-EPD circuit breakers or equivalent for use with all heating circuits. Alternative designs that provide comparable levels of ground-fault protection may also be acceptable. Contact HTD for further information.

---