

# UT550E/UT750E

## Short Form Instruction Manual

*Congratulations on your purchase of the finest controller available.  
This short form guide is designed to speed up your configuration and operation.  
For additional information, please refer to the Instruction Manual on CD-ROM  
provided with the controller*



# UT750/ UT550 USER CONFIGURATION GUIDE

## TABLE OF CONTENTS

	<u>Page</u>
Faceplate Description	
UT550/UT520 .....	1
UT750.....	2
Operating Parameter Maps .....	3
Set-Up Parameter Maps.....	5
Set-Up Procedures	
1) Set-Up Mode .....	7
2) Set Input Type .....	8
3) Set Output Type .....	12
4) Set RS-485 Communications .....	15
5) Set Valve Calibration .....	18
6) Initialization .....	19
7) Loop 1 Parameters.....	20
8) Alarm Parameters .....	21
9) Control Mode Settings.....	24
10) Analog Input Parameters .....	26
11) Retransmission Parameters.....	27
12) Deviation Display.....	28
13) Lockout Parameters.....	29
14) Custom Select Display .....	29
15) Digital Outputs .....	30
16) Digital Inputs.....	32
17) Input Linearizers .....	35
18) Mode Settings.....	34
19) Operating Parameters .....	35
20) PID Parameters.....	37
21) User Parameters.....	41
22) Set Input Linearizer.....	42
<b>Appendix A:</b> LED alphanumeric Characters.....	43
<b>Appendix B:</b> Errors at Power-On.....	44
<b>Appendix C:</b> Operating Errors .....	45
<b>Appendix D:</b> Hardware Specifications.....	46
<b>Appendix E:</b> Installation .....	53
E.1 Location .....	53
E.2 Dimensions .....	54
E.3 Mounting .....	56
E.4 Wiring.....	58
E.5 Terminal Covers .....	61

# UT550 and UT520 Controller Faceplate Description

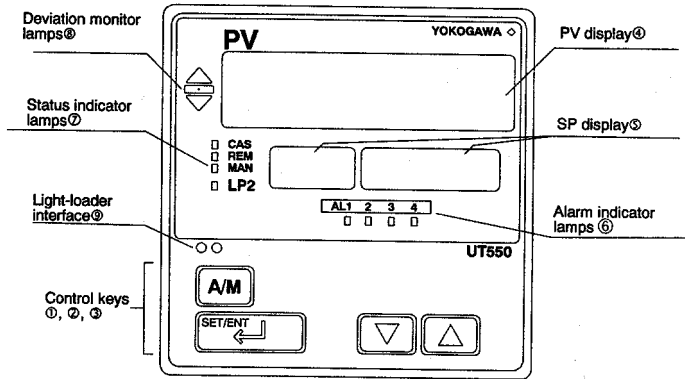

Figure B1-1 UT550 Controller Front Panel

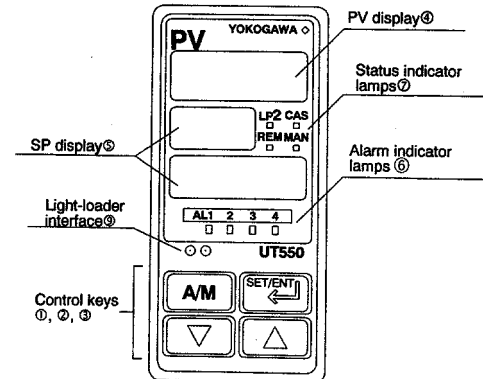

Figure B1-2 UT520 Controller Front Panel

## Control Keys

### Control Keys

No. in Fig.	Key	Function
①		<ul style="list-style-type: none"> <li>Used when registering target setpoints or parameters.</li> <li>Switches an operating or SELECT display to the operating parameter menu display when pressed and held for 3 seconds.</li> <li>Switches a parameter setting or menu display to an operating display when pressed and held for 3 seconds.</li> <li>Used to switch between parameter setting displays.</li> </ul>
②		<ul style="list-style-type: none"> <li>Used when modifying values shown on the SP display.</li> <li>The [▽] (DOWN) key decreases and the [△] (UP) key increases the value displayed on the SP display. Pressing and holding either key gradually raises the value-changing speed.</li> <li>Used to switch between parameter menu displays.</li> <li>Pressing the two keys at the same time returns the current display to a one-level-higher display.</li> </ul>
③		<ul style="list-style-type: none"> <li>Enabled only when an operating display is shown.</li> <li>Switches the operation mode between AUTO and MAN, selecting them alternately each time the key is pressed.</li> <li>Pressing the key in the cascade mode (CAS) switches the operation mode to MAN.</li> </ul>

These control keys are designed to click when pressed. Be sure to press them firmly until you feel clicking.



### NOTE

Do not press the control key with a pen or any sharp-pointed item — doing so may cause a glitch.  
Indicators and Displays

## Display Functions

(Note: Manual indicator light flashes during Auto-tune)

No. in Fig.	Marking	Function
④	PV	This 5-digit LED display shows process variables (PV) or the error code if an error is caused.
⑤	LCD display	Displays target setpoints (SP) or output data (OUT) in an operating display. The 3-digit LED display shows a parameter code and the 5-digit LED display shows the parameter setting.
⑥	AL1-4	These four lamps are used to indicate occurrence of alarms 1 through 4 lighting in yellow.
⑦	Status indicator lamps	<p>These status indicator lamps are lighted in green to indicate operating and control status as follows:</p> <ul style="list-style-type: none"> <li>CAS Lights during cascade-mode operation.</li> <li>REM Lights during remote-mode operation.</li> <li>MAN Lights during manual-mode operation.</li> <li>LP2 Lights when a parameter is displayed for the cascade-controlled secondary-loop.</li> </ul>
⑧	Deviation monitor lamps	<p>Deviation monitor lamps (UT550 only).</p> <p>These three indicator lamps are used to indicate the status of deviation (PV-SP) when an operating or SELECT display is shown.</p> <p>△: Lights in yellow when deviation exceeds the high limit of the preset deviation range. □: Lights in green when deviation remains within the range. ▽: Lights in yellow when deviation exceeds the low limit of the range.</p>

# UT750 Controller Faceplate Description

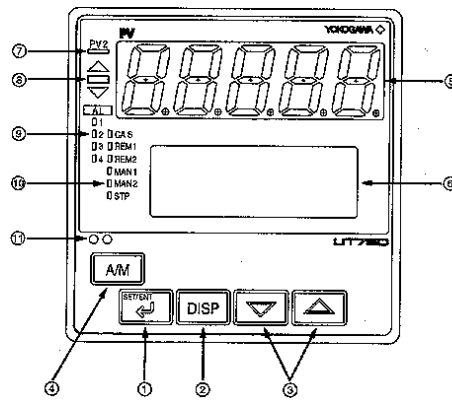

## ● Functions of Control Keys

Number in Figure	Key	Function
①		Used to change the type of parameter or to set its value. Holding this key down for three seconds or longer toggles between an operation display and operating parameter menu display.
②		Used to switch between displays. Pressing this key while an operation display is on display switches to several other types of preset operation displays. Pressing this key while a display other than operation displays is on display returns to an operation display. (The number of presses required to return to an operation display varies depending on the condition in which the UT750 controller operates; however, it is usually from once to three times.)
③	 	Used to change values. Pressing this key while a parameter (operating or setup parameter) setting display is on display changes the value of the target setpoint, parameter, or output (when in manual operation). Press the [▼] key to decrease the value; press the [▲] key to increase the value. Holding down either of these keys gradually increases the speed of the value change. Pressing this key while the display of a first or second parameter (operating or setup parameter) menu is on display switches between the menu displays.
④		Used to switch between the automatic (AUTO) and manual (MAN) operating modes for the primary loop. Each press of this key toggles between the AUTO and MAN modes.

## ● Display Functions

Number in Figure	Indicator/Display	Function
⑤	Process variable (PV) display	Indicates the process variable (PV), or an error code if there is a failure.
⑥	LCD display	Indicates the setpoint (SP), manipulated variable (MV), deviation (DV), deviation trend, valve opening, or the name and setpoint of a setup item such as a parameter.
⑦	Second process variable (PV2) status indicator lamp	Comes on when a PV2 is on the PV display (Note).
⑧	Deviation monitor lamps	Come on to indicate the state of deviation (PV - SP). ▲: comes on if the deviation exceeds the upper limit of the given span--yellow. —: comes on when the deviation is within the given limits of the span--green. ▼: comes on if the deviation falls below the lower limit of the given span--yellow.
⑨	Alarm indicator lamps (ALM1 to ALM4)	Come on when alarms 1 to 4 turn on--yellow.
⑩	Status indicator lamps	Come on to indicate the status of operation and control--green. CAS: comes on when the controller is in cascade control. REM1: comes on when the controller is in remote (REM) operation for the primary loop. REM2: comes on when the controller is in remote (REM) operation for the secondary loop. MAN1: comes on when the controller is in manual (MAN) operation for the primary loop. MAN2: comes on when the controller is in manual (MAN) operation for the secondary loop (Note). STP: comes on when the controller is at a stop (STOP).

# OPERATING PARAMETER MAP

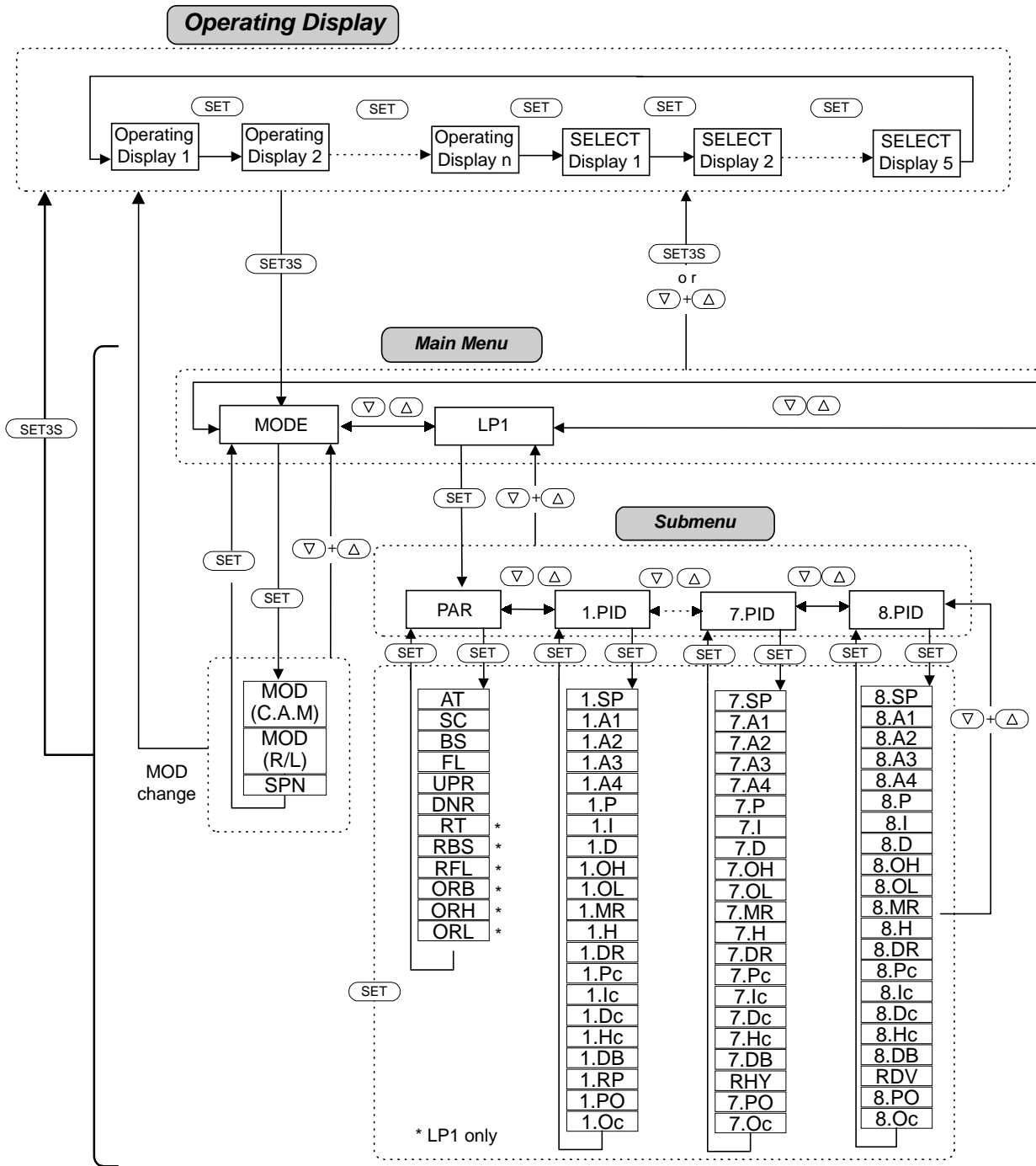

- (SET)    ●●● SET/ENT key
- (SET3S) ●●● SET/ENT key for 3 second
- (▽) (Δ) ●●● ▽ key or Δ key
- (▽)+(Δ) ●●● ▽ key and Δ key simultaneously

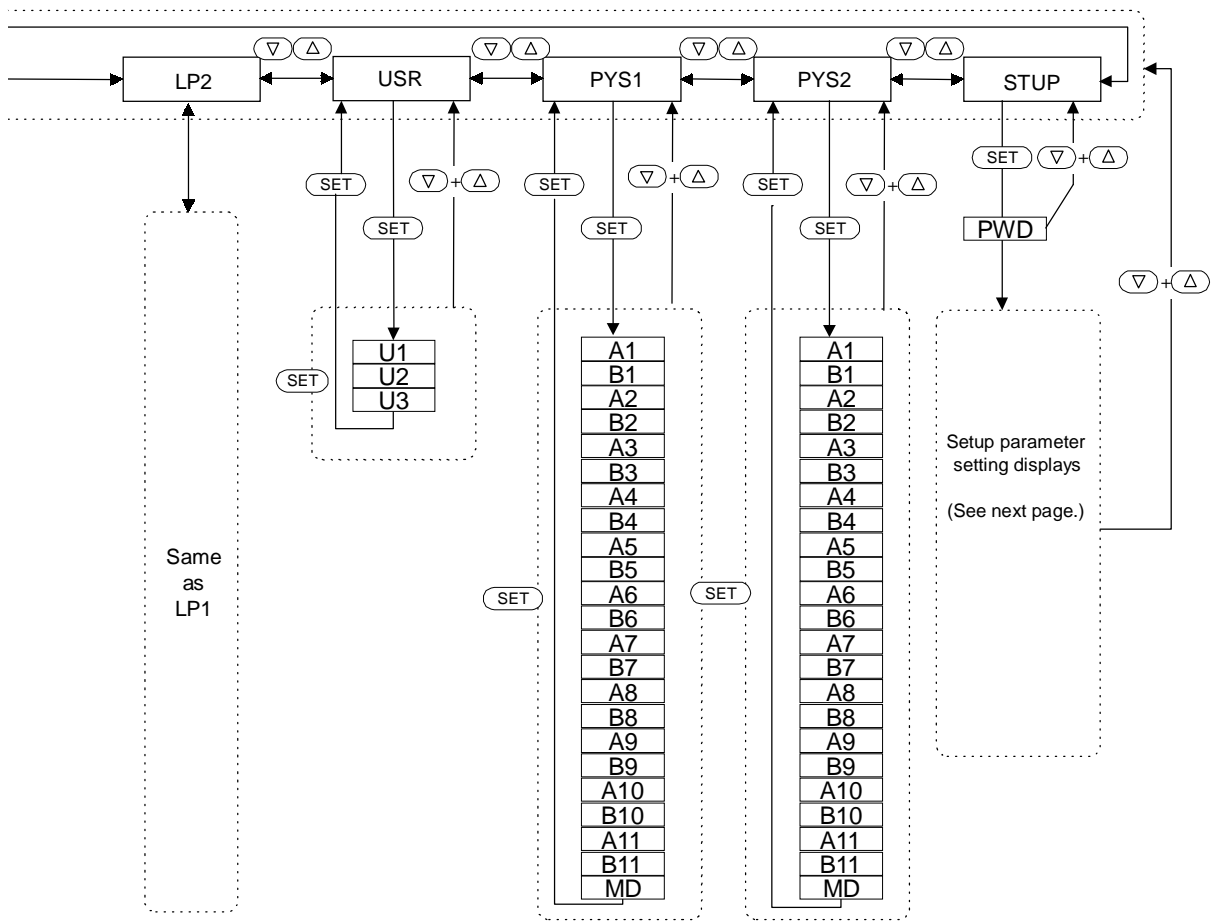

# SETUP PARAMETER MAP

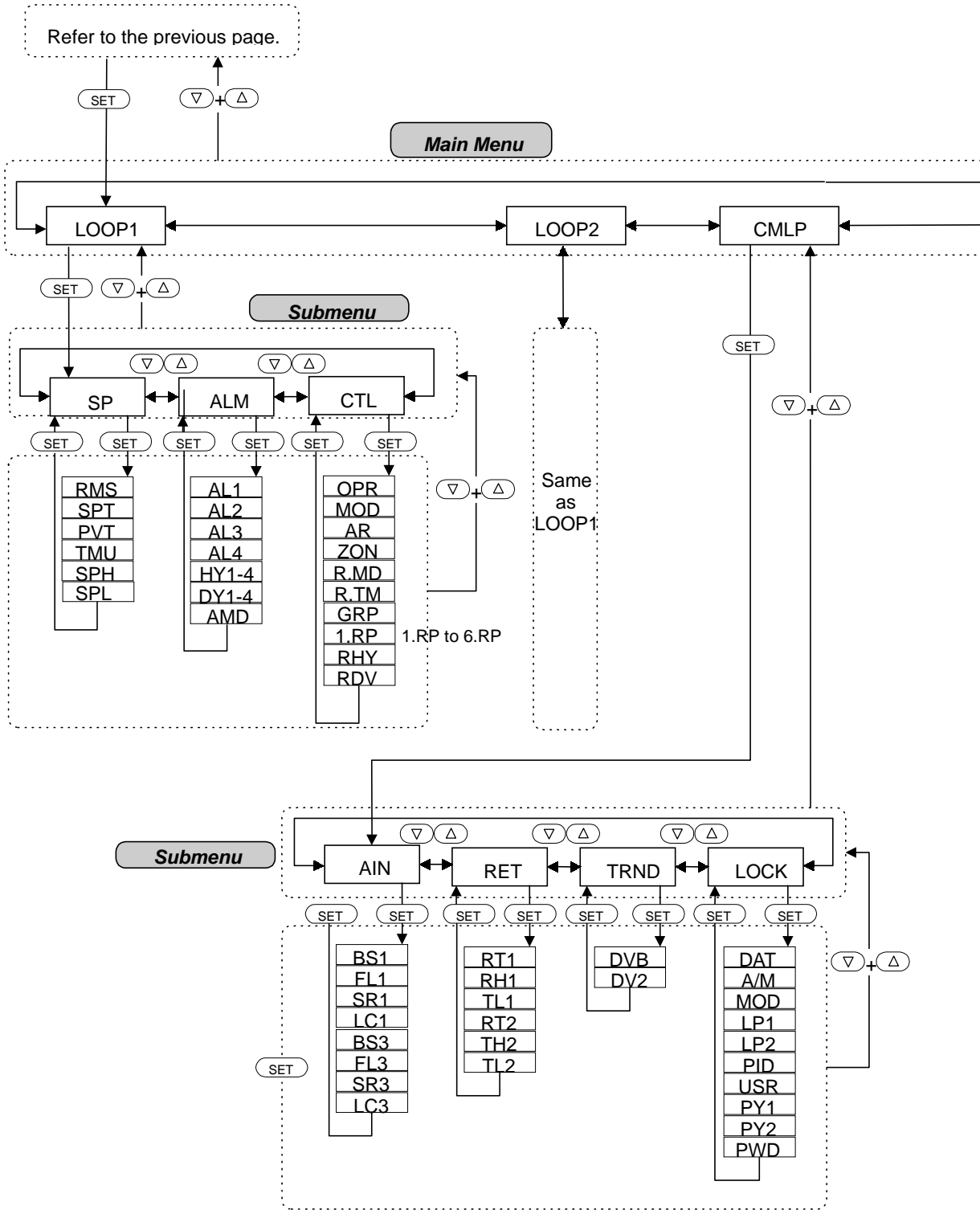

- (SET) ... SET/ENT key
- (SET3S) ... SET/ENT key for 3 second
- (▽)(△) ... ▽ key or △ key
- (▽)+(△) ... ▽ key and △ key simultaneously

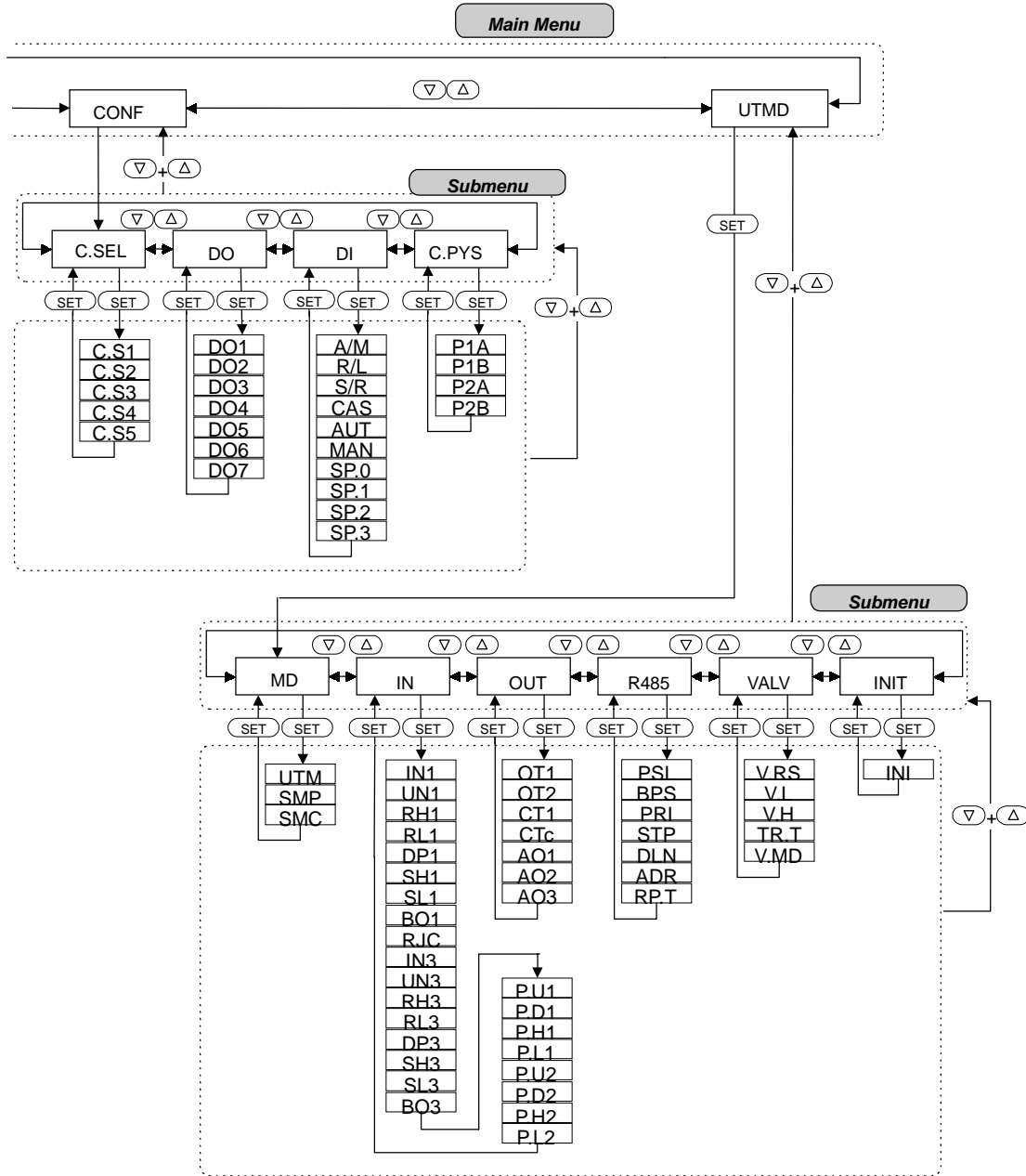

PLEASE NOTE: Model number and/or UT Mode selected will determine which of the following configuration menu's are accessible, i.e. USR configuration menu will not display if unit is in UT Mode #13 for cascade control. **Note: For initial Setup you must start here and complete all these initial parameters**

- (^) = Up Arrow key
- (DISP) = Display key
- (SET/ENT) = Set Enter key



# 1) SET UT MODE

- A) Press (SET/ENT) three seconds
- B) Press (V) & toggle to STUP (password input)
- C) Press (SET/ENT) then (V) to UTMD (SETUP main menu).
- D) Press (SET/ENT) MD (UT mode set, SETUP sub menu)
- E) Press (SET/ENT) MENU:UTMD/MD (UT mode select, #1 screen). UTM = ?.

When UTM number is assigned press (SET/ENT) to register the new mode - screen will black out for three seconds and will then return to operating display menu. Return to MD (UT mode set, SETUP sub menu).

- A) Press SET/ENT) twice and specify SMP
- B) Press (SET/ENT) and specify SMEC

	Symbol	Description	Setting range	Factory setting
UTMD	UTM	UT MODE	1: Loop control 2: Cascade primary loop control 3: Cascade secondary loop control 4: Cascade control 5: Loop control for backup 6: Loop control with PV switching 7: Loop control with PV auto-selector 8: Sample & hold – 550 only 11: Dual loop control 12: Temperature and humidity control 13: Cascade control with 2 universal inputs 14: Loop control with PV switching & 2 universal inputs 15: Loop control with PV auto-selector & 2 universal inputs (Note)	1: <div style="display: inline-block; vertical-align: middle; margin-left: 20px;">             } UT750 Only           </div>
	SMP	Input sampling period	0 (50ms), 1(100ms), 2(200ms), 3(500ms)	2(200ms)
	SMEC	Sampling period error counter	0 to 30000	0

**UTM - UT Mode Select:** Select the UT Mode available for the model selected.

**SMP & SMEC:** Input sampling period & Sampling period error counter: The sampling interval for the measurement input of the controller can be changed. This function is effective in checking the sampling interval of the controller when you create a custom computation. The sampling error counter counts the times when the actual sampling interval exceeds its preset value. Using the sampling intervals and sampling error counter will approximate sampling intervals in which the controller performs the custom computation.

## 2) SET INPUT TYPE

- A) Press (^) IN (input set, SETUP sub menu)  
 B) Press (SET/ENT) and specify IN1~ UNI1 ~ RH1 ~ RL1 ~ SDP1~ SH1 ~ SL1 ~ BSL1 ~ RJC1 ~ IN2 ~ UNI2 ~ RH2 ~ RL2 ~SDP2 ~ SH2 ~SL2 ~ BSL2 ~ RJC2 ~ IN3 ~ UNI3 ~ RH3 ~ RL3 ~ SDP3 ~ SH3 ~ SL3 ~ BSL3 ~ PDP1 ~ P.UN1 ~ P.DP1~ P.RH1 ~ P.RL1 ~ PDP2 ~ PUN2 ~ PHH2 ~ PRL2

	Symbol		Description	Setting range	Factory setting
	UT550	UT750			
IN	In1	IN1	Input 1 type (T/C, RTD, mV or VDC)	See table Page 10	OFF (No input selection)
	Un1	UNI1	Input 1 units	°C, % °F	°C
	rH1	RH1	Input 1 range maximum value	Input Range of IN1	Maximum value of equipment range
	rL1	RL1	Input 1 range minimum value		Minimum value of equipment range
	dP1	SDP1	Input 1 decimal point position	Thermocouple and RTD: Decimal point position of equipment range is displayed (cannot be changed), DC voltage: 0 to 4	Decimal point of equipment range, DC voltage :2
	SH1	SH1	The maximum value of input 1 scaling is displayed when a voltage is input	DC voltage: -19999 to 32000 Where, SL1 , Sh1, SH1-SL1≤ 30000	When DC voltage is selected: 10000
	SL1	SL1	The minimum value of input 1 scaling is displayed when a voltage is input.		When DC voltage is selected: 000
	bo1	BSL1	When input 1 burnout operation is selected	OFF, UP, DOWN	UP
	JC	RJC1	Input 1RJC ON/OFF	OFF, ON	ON
IN	---	IN2	Input 2 classification	See the table Page 10	1 (Type K)
	---	UNI2	Input 2 unit specification	°C, % , °F	°C
	---	RH2	Input 2 range maximum value	Range of equipment range	Maximum value of instrument range
	---	RL2	Input 2 range minimum value		Minimum value of instrument range
	---	SDP2	Input 2 decimal point position	Thermocouple and RTD: Decimal point position of instrument range is displayed (cannot be changed). DC voltage: 0 to 4	Decimal point of instrument range, DC voltage:2
	---	SH2	The maximum value of input 2 scaling is displayed when a voltage is present.	DC voltage : -19999 to 32000 Where, SL1 < SH1 < 30000	When DC voltage is selected: 10000
	---	SL2	The minimum value of input 2 scaling is displayed when a voltage is present.		When DC voltage is selected : 000
	---	BSL2	Input 2 burnout protection selected.	OFF, UP, DOWN	UP
	---	RJC2	Input 2RJC ON/OFF	OFF, ON	ON
	In3	IN3	Input 3 classification	See the table Page 10	41 (1-5VDC)
	Un3	UNI3	Input 3 unit specification	°C, % , °F	%
	rH3	RH3	Maximum value of input 3 range	Range of instrument range	5.000
	rL3	RL3	Minimum value of input 3 range		1.000
	dP3	SDP3	Decimal point position of input 3	DC voltage : 0 to 4	Decimal point position of Instrument range, DC voltage: 2
	SH3	SH3	The maximum value of input 3 scaling is displayed when a voltage is input	DC voltage: -19999 to 32000 Where, SL1 < SH1-	When DC voltage is selected: 10000
	SL3	SL3	The minimum value of input 3 scaling is displayed when a voltage is input		When DC voltage is selected: 000
	b3	BSL3	Input 3 burnout protection selected	OFF, UP, DOWN	OFF

	Symbol		Description	Setting range	Factory setting
	UT550	UT750			
IN	P.U1	PDP1	PV1 unit specification	°C, % , °F	°C
	P.d1	PUN1	PV1 decimal point position	0 to 4	Same as DP1
	P.H1	PRH1	Maximum value of PV1 range	Thermocouple, RTD, DC voltage: - 19999 to 32000	Thermocouple, RTD: RL1 DC voltage: 10000
	P.L1	PRL1	Minimum value of PV1 range	Where PRL1 < PRH1, PRH1 - PRL1 ≥ 30000	Thermocouple, RTD: RL1 DC voltage: 0
	---	PDP2	PV2 unit specification	°C, % , °F	°C
	---	PUN2	PV2 decimal point position	0 to 4	Same as DP1
	---	PRH2	Maximum value of PV2 range	Thermocouple, RTD, DC voltage: - 19999 to 32000	Thermocouple, RTD : RH2 DC voltage: 10000
	---	PRL2	Minimum value of PV2 range	Where PRL1 < PRH1, PRH1 - PRL1 ≥ 30000	Thermocouple, RTD: RL2 DC voltage: 0

**IN** - Input type selection: The input type is set and the linear rise is computed with selection of the input type. The input types are shown in the table below. The auxiliary input (IN3) can only use DC voltage inputs.

Input Classification	Input Type	Instrument Input Range		Instrument Input Range Code	
				UT750	UT550
Thermocouple	K	-200.0 to 1370.0°C	-300.0 to 2500.0°F	typeK1	1
	K	-200.0 to 1000.0°C	0.0 to 2300.0°F	typeK2	2
	K	-200.0 to 500.0°C	-200.0 to 1000.0°F	typeK3	3
	J	-200.0 to 1200.0°C	-300.0 to 2300.0°F	typeJ	4
	T	-200.0 to 400.0°C	-300.0 to 750.0°F	typeT1	5
	T	0.0 to 400.0°C	-200.0 to 750.0°F	typeT2	6
	B	0.0 to 1800.0°C	32 to 3300°F	typeB	7
	S	0.0 to 1700.0°C	32 to 3100°F	typeS	8
	R	0.0 to 1700.0°C	32 to 3100°F	typeR	9
	N	-200.0 to 1300.0°C	-300.0 to 2400.0°F	typeN	10
	E	-200.0 to 1000.0°C	-300.0 to 1800.0°F	typeE	11
	L	-200.0 to 900.0°C	-300.0 to 1600.0°F	typeL	12
	U	-200.0 to 400.0°C	-300.0 to 750.0°F	typeU2	13
	U	0.0 to 400.0°C	-200.0 to 1000.0°F	typeU2	14
	W	0.0 to 2300.0°C	32 to 4200°F	typeW	15
	Platinel 2	0.0 to 1390.0°C	32.0 to 2500.0°F	plati2	16
	PR20-40	0.0 to 1900.0°C	32 to 3400°F	PR2040	17
	W97Re3-W75Re25	0 to 2000.0°C	32 to 3600°F	W97Re3	18
RTD	Jpt100	-200.0 to 500.0°C	-300.0 to 1000.0°F	JPt1	30
	Jpt100	-150.0 to 150.00°C	-200.0 to 300.0°F	JPt2	31
	Pt100	-200.0 to 640.0°C	-300.0 to 1180.0°F	Pt1	35
	Pt100	-200.0 to 500.0°C	-300.0 to 1000.0°F	Pt2	36
	Pt100	-150.00 to 150.00°C	-200.0 to 300.0°F	Pt3	37
Standard Signal	0.4 to 2V	0.400 to 2.000	The ranges on the left can be scaled to within a 30,000 count range	0.4 ~ 2V	40
	1 to 5V	1.000 to 5.000		1~5V	41
DC voltage	0 to 2V	0.000 to 2.000		0~2V	50
	0 to 10V	0.00 to 10.00		0~10V	51
DC voltage	-10 to 20mV	-10.00 to 20.00		mV1	55
	0 to 100mV	0.000 to 100.0		mV2	56

**UNI** - Unit selection: Set degrees C, F or %

**RH & RL** - Range High & Range Low: Analog input range - set values within the instrument range.

**SDP** - Decimal Point Position: Analog input decimal point location - set the number of digits to the right of the decimal point. 0 = no digits beyond the decimal point; 1 = 1 digit past the decimal point; 4 = 4 digits to the right of the decimal point. Setting is not needed for thermocouple and RTD inputs.

**SL & SH** - Scale Low & Scale High: Input scaling limits - Set the commercial scale of the DC voltage input: 0.0 to 600.0 t/h, 4.0 to 12.0 pH, etc. The default is 0.0 - 100.0 (no units).

**BSL** - Burn Out Select: Set the burnout protection for each input in the case of thermocouple, RTD, and standard signal inputs.

**RJC** - Reference junction compensation: Set the on/off status of the reference junction compensation for thermocouple inputs 1 and 2. Set off when the reference junction compensator or the like is used in the exterior of the controller and precise compensation is carried out.

**PDP** - Process Variable Unit Select: Set degrees C, F or %

**PUN**- Process Variable decimal point location: Also used for PV range conversion if the process variable ranges of 2 input signals are different during 2-input changeover control or input selection control. It sets the high and low limits of the process variable range, Pvn (n=1, 2) after input 1 (IN 1) and input 2 (IN 2) undergo analog input range conversion, bias, filter and other input computations.

**PRH & PRL** - PV range high limit & low limit: Both within analog input range.

### 3) SET OUTPUT TYPE

- A) Press (^) OUT (output set, SETUP sub menu)
- B) Press (SET/ENT) and specify OT1 ~ OT2 ~ CT1 ~ CT2 ~ Ctc1 ~ Ctc2 ~ AO1 ~ AO2 ~ AO3

	Symbol	Description	Setting range	Factory setting
OUT	OT1	Control output 1 selection	0: Time Proportional Relay 1: Time Proportional Voltage pulse 2: Current output 3: ON/OFF control (relay) 4 to 12: Heating/cooling control See Page 13.	0
	OT2	Control output 2 selection	Same as above	0
	CT1	Control output 1-cycle time	1 to 1000 seconds	30
	CT2	Control output 2-cycle time	1 to 1000 seconds	30
	Ctc1	Cooling side control output 1-cycle time	1 to 1000 seconds	30
	CTc2	Cooling side control output 2-cycle time	1 to 1000 seconds	30
	AO1	Analog output type 1 (for control output 1)	0: 4 to 20mA 1: 0 to 20mA } 2: 20 to 4mA 3: 20 to 0mA } 2: & 3: are applicable only to UT550/UT520	0
	AO2	Analog output type 2 (for control output 2)		
AO3	Analog output type 3 ( for RET1)			

**OT** - Output: Output of the loop is determined on the basis of setup parameter OT and the type of control (PID control or heating/cooling PID control). Retransmission output 1, retransmission output 2, and the alarm output, may not be available depending on the control output classification. For example, when the output in PID control is a continuous current signal, OT1=2 is set. At that point, the retransmission output and alarm output can be used. In heating/cooling PID control, when the heating- side output is a current pulse and the cooling-side output is a transistor output, OT1=8 is set. At this time the retransmission output and alarm output can be used.

OT1	Control type	Symbol and classification of output terminal				
		OUT1A Current/pulse 1	OUT3A Current/pulse 3	RL1 Relay contact	DO3 Relay contact	DO4 Transistor contact
0	Time proportional PID	Retransmission output 2	Retransmission output 1	Control output	Alarm output	Alarm output
1	↑	Pulse control output	↑	Not used	↑	↑
2	Continuous PID	Current control output	↑	↑	↑	↑
3	On/off control	Retransmission output 2	↑	Control output	↑	↑
4	Heating/cooling control	↑	↑	Heating-side output	Cooling-side output	↑
5	↑	Heating pulse control output	↑	Not used	Cooling-side output	↑
6	↑	Heating current control output	↑	↑	Cooling-side output	↑
7	↑	Retransmission output 2	↑	Heating-side output	Alarm output	Cooling-side output
8	↑	Heating pulse control output	↑	Not used	↑	Cooling-side output
9	↑	Heating current control output	↑	↑	↑	Cooling-side output
10	↑	Retransmission output 2	Cooling current control output	Heating-side output	↑	Alarm output
11	↑	Heating pulse control output	Cooling current control output	Not used	↑	↑
12	↑	Heating current control output	Cooling current control output	Not used	↑	↑

OT2	Control type	Symbol and classification of output terminal			
		OUT2A Current/pulse 1	RL2 Relay contact	DO2 Relay contact	DO5 Transistor contact
0	Time proportional PID	Retransmission output 2	Control output	Alarm output	Alarm output
1	↑	Pulse control output	Not used	↑	↑
2	Continuous PID	Current control output	↑	↑	↑
3	Time proportional PID	Retransmission output 2	Control output	↑	↑
4	Heating/cooling	↑	Heating-side output	Cooling-side output	↑
5	↑	Heating pulse control output	Not used	Cooling-side output	↑
6	↑	Heating current control output	↑	Cooling-side output	↑
7	↑	Retransmission output 2	Heating-side output	Alarm output	Cooling-side output
8	↑	Heating pulse control output	Not used	↑	Cooling-side output
9	↑	Heating current control output	↑	↑	Cooling-side output

- OUT1A = OUT (output) 1 (loop 1) A (analog): Terminals 16 & 17
- OUT2A = OUT (output) 2 (loop 2) A (analog): Terminals 46 & 47
- OUT3A = OUT (output) 3 (3rd out) A (analog): Terminals 14 & 15
- RL1 = Relay contact output for control (loop 1) Terminals 1, 2 & 3
- RL2 = Relay contact output for control (loop 2) Terminals 48, 49 & 50
- DO2 = Digital output #2 (relay contact) Terminals 5 & 7
- DO3 = Digital output #3 (relay contact) Terminals 4 & 7
- DO4 = Digital output #4 (transistor contact) Terminals 34 & 35
- DO5 = Digital output #5 (transistor contact) Terminals 33 & 35

OUT1A is used for current control output, pulse control output or retransmission output depending on (OT1) control type selected from above table. OUT3A is used for retransmission/loop power supply (user selectable) depending on (OT1) control type selected from above table. RL1 is used for control output or heating side (heat/cool type) control output only. DO3 & DO4 are assigned to cooling side control outputs or alarm outputs depending on (OT1) control type selected from above table

Position proportional model that has only (1) one control output type available (Relay contact, terminals 48,49 & 50). Heating/Cooling option is not available on this unit. Retransmission/loop power supply (user selectable) available: terminals 14 & 15.

**UT750-50/70-00 ~ UT750-50/70-10:** OUT2A is used for current control output, pulse control output or retransmission output depending on (OT2) control type selected from above table. RL2 is used for control output or heating side (heat/cool type) control output only. DO2 & DO5 are assigned to cooling side control outputs or alarm outputs depending on (OT2) control type selected from above table.

**CT - Cycle Time Proportional PID Control:** Time proportional PID control outputs the PID computation results with the on/off signal pulse width proportional to the time. The pulse width is calculated as the control output x cycle time, with the cycle time (control output cycle) at 100%. The output type is selected from the relay output and the voltage pulse output. Shortening the cycle time for very fine control may shorten the life of the controller output relay and the input junctions on the operating side due to a greater number of on/off operations. Generally about 10 to 30 seconds are set for the relay output.

**AO1, AO2, and AO3:** Designate the type of analog output signal required. AO1 corresponds to OUT1A, AO2 to OUT2A, and AO3 to OUT3A. There are four types of analog signals: 0: 4~ 20mA, 1: 0~20mA, 2: 20~4mA and 3: 20~0mA.



## 4) Set RS485 Communications

- A) Press (^) R485 (RS485 condition set SETUP sub menu)  
 B) Press (SET/ENT) and specify PSL1 ~ BPS1 ~ PR11 ~ STP1 ~ DLN1 ~ ADR1 ~ RP.T1 ~ PSL2 - BPS2 ~ PR12 ~ STP2 ~ DLN2 ~ ADR2 ~ RP.T2

	Symbol	Description	Setting range	Factory setting
RS485	PSL1	Protocol selection 1	0: Computer link 1: Computer link ( with sum check) 2: Ladder communication 3: Master controller for coordinated operation 4: Slave controller for coordinated operation 7: Modbus (ASCII) 8: Modbus (RTU)	0
	BPS1	Communication speed 1	600, 1200, 2400, 4800, 9600	9600
	PR11	Parity 1	None, Even, Odd	Even
	STP1	Stop bit 1	1, 2	1
	DLN1	Data length	7, 8 ; Set to 8 when not using computer link	8
	ADR1	Address 1	1 to 99, maximum 31 controllers	1
	RP.T1	Minimum response time 1	0 to 10x10ms	0
	PSL2	Protocol selection 2	0: Computer link 1: Computer link (with sum check) 2: Ladder communication 3: Master controller for coordinated operation 4: Slave controller for coordinated operation 5: I/O expansion (first module) 6: I/O expansion (second module)	UT750-□1 Only
	BPS2	Communication speed 2	600, 1200, 2400, 4800, 9600, 19200, 38400	9600
	PR12	Parity 2	None, Even, Odd	Even
	STP2	Stop-bit 2	1, 2	1
	DLN2	Data length 2	7,8: Set to 8 for other than computer link	8
	ADR2	Address 2	1 to 99, maximum 31 controllers	1
	RP.T2	Minimum response time 2	0 to 10 x 0mS	0

UT750 can accommodate up to two communication interfaces. Using the interfaces, the following types of communication are available between various devices.

Communications Interface	4- wire/ 2 - wire RS-485 communication	2- wire high-speed RS-485 communication
Terminal	Port 1 (Terminal numbers 23, 24, 25, 26, 27)	Port 2 (Terminal numbers 28, 29, 30)
Use	PC link communication (slave station) PC link communication with checksum (slave station) Ladder communication (slave station) Remote operation (master station) Remote operation (slave station)	PC link communication (slave station) PC link communication with checksum (slave station) Ladder communication (slave station) Remote operation (master station) Remote operation (slave station) Remote I/O (master station)
Maximum communication rate	9600 bps	38.4 kbps (1.25 Mbps (fixed) for I/O expansion)

PC link communication (slave station) is used to communicate with PC's, graphic displays, or programmable controllers (PLCs). PC link communication with checksum (slave station) is the same as standard PC link communication (slave station) except that it has an added function that checks the size of communication protocols.

Ladder communication (slave station) is used for communicating with PLCs (e.g., FA-M3, FA500).

Coordinated communication (master station) is used to control the operation pattern of the controller in the coordinated communication (slave station) mode.

Coordinated communication (slave station) is used to control the operation pattern of the controller in the coordinated communication (master station) mode.

Modbus communication is available in an ASCII or RTU (binary) format.

Use	Connected Device	Applicable Model
PC link communication/PC link communication with checksum	PC	General-purpose PC
	Display	Same as above
	Serial communication module (FA-M3, FA500)	Model: F3RS41- on (FA-M3)
		Model: RS42- on (FA500)
Ladder communication	Ladder communication module (FA-M3, FA500)	Model: F3RZ91- on (FA-M3)
		Model: RZ91- on (FA500)
Coordinated communication	UP750 program controller (master station)	Model: UP750-□1, UP550-□1
	UT750 digital indicating controller (master/slave station)	Model: UT750-□1, UP550-□□
I/O Expansion	Digital I/O expansion module	Model: P2ER1-20J
		Model: P2ET1-20J
		Model: P2ER6-20J
		Model: P2ET6-20J

The high-speed RS-485 communications interface share a terminal I/O expansion. To select the terminal functions, set the setup parameters.

- High-speed RS-485 communications interface

Item	Specification
Standard	Conforming to EIA RS485
Number of devices available for Connection	31
Communications type	2-wire, half-duplex
Synchronization	Asynchronous (start-stop)
Communication protocol	Handshaking
Communication distance	1200 m
Communication rate	600, 1200, 2400, 4800, 9600, 19.2k, 38.4k
Start bit	1
Data length	7 or 8
Parity	No parity, even, odd
Stop bit	1 or 2

•Remote I/O interface

Item	Specification
I/O Expansion module	Digital I/O expansion module, 8 input points, 8 output points
Number of devices available for connection	Two
Communication distance	15 m

Communications Interface

Item	Specification
Standard	Conforming to EIA RS485
Number of devices available for connection	31
Communication type	2-wire, half-duplex
Synchronization	Asynchronous (start-stop)
Communication protocol	Handshaking
Communication distance	1200 m
Communication rate	600, 1200, 2400, 4800, 9600
Start bit	1
Data length	7 or 8
Parity	No parity, even, odd
Stop bit	1 or 2

## 5) Set up Valve Calibration – For position proportional outputs only UT550-1 and UT750-1

- A) Press (^) VALV (VALVE control, SETUP sub menu)  
B) Press (SET/ENT) and specify V.RS ~ V.L ~ V.H ~ TR.T ~ V.MOD

	Symbol	Description	Setting Range	Factory Setting
VALV	V.RS	Resetting of valve position setting	When 1 is set, the valve adjustment value is reset, 0 and the decimal point flashes	0
	V.L	Setting of valve fully closed position	If the valve is put in the fully closed position and 0 the SET/ENT key pressed, the adjustment value is stored in the memory. If then both V.L. and V.H. are adjusted, the flashing of the decimal point stops	0
	V.H	Setting of valve fully open position	If the valve is put in the fully open position and 0 the SET/ENT key pressed, the adjustment value is stored in the memory. If then both V.L. and V.H. are adjusted, the flashing of the decimal point stops	0
	TR.T	Valve operation time	5 to 300 seconds	60
	V.MOD	Valve adjustment mode	0: Feedback type 1: Feedback type ( Changes to estimation type in Feedback type event of VP input error or open circuit) 2: Estimation type	0:
	INIT	Parameter initialization	OFF, ON (Initialized other than in UT mode)	OFF

Position proportional PID control is a control system that collates the controller's output signal and the control valve's signal to open so that the valve's opening always matches the control output. Depending on how the valve's signal to open is handled, there are two types of systems: a feedback system and one in which the valve position is assumed. This function can be used with the UT550-1 and UT750-1.

- (1) Valve position feedback is a system in which the valve's signal to open is obtained from a feedback slide (also referred to as a slide resistor) installed on the valve. A potentiometer is mounted on the valve stem and linked to the motor: the resistance value varies in proportion to the valve stem's position (opening of the motor operated valve). The UT550/UT750 measures the valve's opening according to this resistance value signal. The valve's position is expressed as OUT (output value). When the  $\Delta$  key is pressed during manual operation, the output on the side where the motor-operated valve's opening increases is turned on, and when the  $\nabla$  key is pressed, the output on the side where the motor-operated valve's opening decreases is turned on. When the power is switched on, operation in both the AUTO and MAN operating modes is based on the valve position at the time the power is switched on.
- (2) Assumed Valve Position is a system in which the feedback signal of a motor-operated valve's opening cannot be obtained. This control system sets the target motor-operated valve's movement from fully open to fully closed according to the valve's movement time (TR.T), and assumes the valve position from the movement time. The accurate setting of the motor-operated valve's movement time is essential for good control.

**V.RS** - Reset of Valve Position Setting: The valve position setting data is eliminated in position feedback. When the valve is newly adjusted first eliminate the previous setting. The current valve position can be read by pressing the SET/ENT key when V.RS = 0. Setting range: 0 = Reading of current valve opening, 1: Position setting data reset.

**V.L.** - Valve Fully Closed Position: This parameter sets the valve fully closed in valve position feedback. If the SET/ENT key is pressed when the valve is fully closed the valve position on the fully closed side is set.

**V.H.** - Valve Fully Open Position: This parameter sets the valve fully open in valve position feedback. If the SET/ENT key is pressed when the valve is fully open the valve position on the fully open side is set.

**TR.T** - Valve Movement Time: This parameter is used with the assumed valve position system. Valve movement time range: 5 to 300 seconds.

**V.MOD** - Valve Adjustment Mode: Sets the control method for position proportional control. 0 (feedback), 1 (moves to assumed valve position if valve input error or power disconnection occurs) & 2 (assumed valve position).

## 6) Initialization

**NOTE: Executing this function initializes (resets) all parameters to the factory-set values**

- A) Press (^) INIT (parameter initialize, SETUP sub menu)
- B) Press (SET/ENT) and specify ON \*\* Note - Display screen will blank out for two seconds.

**INIT:** This function initializes setup and operation parameters except for the UT mode setting controls, inputs & output parameters, communication parameters & valve calibration. **EXECUTING THIS FUNCTION INITIALIZES ALL PARAMETERS TO THE FACTORY-SET VALUES.** Also, this function allows you, after setting up the range and scale by entering the input/output parameters, to set the other parameters related to those range and scale setups (e.g., the PV range of the transmitter output).

## 7) Loop1 Parameters

- A) Press (DISP) UTMD
  - B) Press (^) LOOP1
  - C) Press (SET/ENT) SP (SP control, SETUP sub menu)
  - D) Press (SET/ENT) and specify RMS ~ SPT ~ PVT ~ TMU
- \*\*\*If dual input press (DISP), (^) then (SET/ENT) for loop 2 set point control

	Symbol	Description	Setting Range	Factory Setting	CS #
SP For loop n n= 1, 2	RMS	Remote input selection	RSP (RSP), communication (COM)	RSP	901
	SPT	SP tracking ON/OFF	OFF, ON	ON	902
	PVT	PV tracking ON/OFF	OFF, ON	OFF	903
	TMU	Slope time unit	Hours: Minutes (0), Minutes: Seconds (1)	0	904
	SPH	Set Point high limit	0.0 to 100.0% of PV range	100.0% of PV range	
	SPL	Set point low limit	0.00 to 100.0% of PV range	0.00% of PV range	

**RMS** - Remote input selection: Either data through communications or auxiliary analog input is selected as the remote setpoint. RSP - auxiliary analog input signal or COM - data through communications.

**SPT**: When the controller switches from remote setting to local setting, this function makes the local target setpoint (SP) track to the remote setpoint just before the changeover is made. This prevents rapid variations in the setpoint value during remote to local changeover.

**PVT** - Process Variable Tracking: When the controller switches from a non-automatic control status (MAN, STOP) to an automatic control status (AUTO), this function makes the target setpoint track the process variable (PV). In the process variable tracking status, the target setpoint is first aligned with the process variable and then changed to the previously set target setpoint in accordance with the setpoint ramp rate parameters UPR (setpoint up ramp) and DNR (setpoint down ramp). The main application of this function is for controller backup. When another control system is operating under normal conditions, process variable tracking is engaged, and when there is trouble in (the control system and the controller switches to backup status, the process variable before the changeover is controlled as the target setpoint.

**TMU** - Slope time unit: 0-hours, 1-minutes

**SPH & SPL** - Limits the set point from being set below the SPL value or higher than the SPH value.

## 8) Alarm Parameters

- A) Press (^) ALM (alarm control SETUP sub menu)  
 B) Press (SET/ENT) and specify AL1 ~ AL2 ~ AL3 ~ AL4 ~ HY1 ~ HY2 ~ HY3 ~ HY4 ~ AMD  
 \*\*\* If dual input press (DISP), (^), (SET/ENT) then (^) for loop 2 alarms.

	Symbol	Description	Setting range	Factory setting	CS #
ALM For loop n N= 1, 2	AL1	Alarm type 1	OFF, 1 to 24,25 to 31	1: Process variable high limit	915
	AL2	Alarm type 2	OFF, 1 to 20, 25 to 31	2: Process variable low limit	916
	AL3	Alarm type 3	OFF, 1 to 20, 25 to 31	1: Process variable high limit	917
	AL4	Alarm type 4	OFF, 1 to 20, 25 to 31	2: Process variable low limit	918
	HY1	Alarm hysteresis 1	EUS (0.0 to 100.0%)	EUS (0.5%)	919
	HY2	Alarm hysteresis 2	EUS (0.0 to 100.0%)	EUS (0.5%)	920
	HY3	Alarm hysteresis 3	EUS (0.0 to 100.0%)	EUS (0.5%)	921
	HY4	Alarm hysteresis 4	EUS (0.0 to 100.0%)	EUS (0.5%)	922
	DY1	Alarm delay time	0.00 to 99.59 min/sec.	0.00	935
	DY2	Alarm delay time	0.00 to 99.59 min/sec.	0.00	936
	DY3	Alarm delay time	0.00 to 99.59 min/sec.	0.00	937
	DY4	Alarm delay time	0.00 to 99.59 min/sec.	0.00	938
	AMD	Alarm mode	0: Operates continuously 1: OFF in STOP mode 2: OFF in STOP or MAN mode	0	923

AL - Alarm Type: Off, 1~24, 25~31, Refer to Alarm Table Page 22.

Alarm	Action (The "Open" and "Closed" indicate the relay contact statuses and on and off indicate the lamp statuses.)	Alarm type code		Alarm	Action (The "Open" and "Closed" indicate the relay contact statuses and on and off indicate the lamp statuses.)	Alarm type code	
		Contact closed during alarm	Contact open during alarm			Contact closed during alarm	Contact open during alarm
No alarm		OFF					
PV high limit		1		Deviation low limit passive during alarm		6	
		11				16	
PV value low limit		2		Deviation high and low limits		7	
		12				17	
Deviation high limit		3		High and low limits within deviation		8	
		13				18	
Deviation low limit		4		PV value high limit passive		9	
		14				19	
Deviation high limit passive during alarm			5	PV value low limit passive			10
			15				20

SP value high limit		28		Output value high limit		30	
SP value low limit		29		Output value low limit		31	

Alarm type	Alarm setpoint	Alarm type	Alarm setpoint
PV high-limit, no standby	1	PV high-limit, standby	11
PV low-limit, no standby	2	PV low-limit, standby	12
Deviation high-limit, no standby	3	Deviation high-limit, standby	13
Deviation low-limit, no standby	4	Deviation low-limit, standby	14
Deviation high-limit, deenergized, no standby	5	Deviation high-limit, deenergized, standby	15
Deviation low-limit, deenergized, no standby	6	Deviation low-limit, deenergized, standby	16
Deviation high-&low-limit, no standby	7	Deviation high-&low-limit, standby	17
Deviation within high & low limits, no standby	8	Deviation within high & low limits, standby	18
PV high-limit, deenergized, no standby	9	PV high-limit, deenergized, standby	19
PV low-limit, deenergized, no standby	10	PV low-limit, deenergized, standby	20
Timer, upward, hours and minutes	21	Sensor grounding	25
Timer, downward, hours and minutes	22	Alarm diagnosis	26
Timer, upward, minutes and seconds	23	FAIL	27
Timer, downward, minutes and seconds	24	SP high-limit	28
		SP low-limit	29
		Output high-limit*Note	30
		Output low-limit*Note	31



The UT550/UT750 has four alarm output points, each of which can be designated as a process variable alarm or deviation alarm. Also, the alarm setpoint can be changed during operation. The following outputs can be designated as alarms 1 to 4.

- Process variable alarm, deviation alarm (1 ~ 4)
- Timer function (alarm 1 only)
- Sensor grounding alarm (1 ~ 4)
- Problem diagnosis output (1 ~ 4)
- FAIL output (1 ~ 4)

The output terminals of alarms 1 ~ 4 are automatically registered in UT mode shown in table below.

Parameter	Alarm	Terminal (factory setting)
AL1	Alarm 1	DO1 (terminal No. 6)
AL2	Alarm 2	DO2 (terminal No. 5)
AL3	Alarm 3	DO3 (terminal No. 4) or DO5 (terminal No. 33)
AL4	Alarm 4	DO4 (terminal No. 34) or DO6 (terminal No. 32)

**HY** - Hysteresis: The alarm hysteresis width can be set independently for each alarm 1 ~ 4.

**AMD** - Alarm Mode: Set for on/off operation in alarms 1 ~ 4.

- 0: Alarm always on
- 1: Alarm off during manual (MAN) operation
- 2: Alarm off during manual operation shutdown (STOP) status

## 9) Control Mode Settings

- A) Press (^) CTL (control parameter SETUP sub menu)  
 B) Press (SET/ENT) and specify OPR ~ MOD ~ AR ~ ZON ~ R.MD ~ R.TM  
 \*\*\* If dual input press (DISP), (^), (SET/ENT) then (^) twice for control parameters loop 2.

	Symbol	Description	Setting range	Factory setting	CS #
CTL For loop n n= 1, 2	OPR	Output rate-of-change limiter	OFF, 0.0 to 100.0% /second	OFF	926
	MOD	PID control mode	0: Batch control, 1: Constant value control	0	927
	AR	Anti-reset windup	Auto (0), 50.0 to 200.0	0	928
	ZON	Zone PID selection	0: SP number selection, 1: Zone selection	0	929
	R.MD	Restart mode	Continuous (CONT), manual (MAN), auto (AUTO)	CONT	930
	R.TM	Restart timer	0 to 10 seconds	0 seconds	931

The symbols ZON, R.MD and R.TM are in loop 1 only, however their functions are common to both loop 1 and loop 2.

**OPR** - Output velocity limit: Prevents severe variations of the control output. This protects the operating terminals and the devices being controlled. Since the output velocity limit negates derivative action caution must be exercised when it is used with controls equipped with derivative action. Example, when set to 2%/second, the output varies from 0 to 100% in 50 seconds

**MOD** – Control Mode: Some applications weren't particularly well suited for PID control. Fast loops tend to become unstable upon SP changes or process upsets. Other loops create instability by the output "bump" caused by the derivative term during SP changes.

On these types of loops we've always set the controller for PI control (no D) and accepted the slowed response or overshoot. Now with Control Mode set at "0" our conventional (excellent) control is executed. If Control Mode is set at "1" (Fixed-point control) the new strategy is implemented. When Fixed Point Control is selected the "Bump" on the output, due to the derivative terms, result from a set change is ignored. The process becomes smooth and steady. On fast loops set Mod to "1" to use P I & D Control, on slower loops (temperature) set Mod to "0".

MOD	Control Mode	Operating Mode	PID control system
0 Factory Setting	Batch control (follow-up control)	Local operation or AUTO operation (cascade control primary -side loop)	PV-derivative PID
		Remote operation or cascade operation (cascade control secondary-side loop)	Derivative-of-deviation control PID
1	Fixed-point control	Local operation or AUTO operation (cascade control primary-side loop)	PV-derivative PID (during setpoint modification, without output bump)
		Remote operation or cascade operation (cascade control secondary-side loop)	Derivative-of-deviation control PID

**AR** - Anti -Reset Windup: When a large deviation continues for a long time during the start of the control operation or at other times, the control output reaches the output limit due to integral action, and becomes saturated. Since the control output cannot break away from the state of saturation even if the process variable input exceeds the setpoint value, overshooting occurs. The anti-reset windup function prevents overshooting by stopping integral computation when the operating output exceeds the setpoint, thus preventing windup. The anti-reset windup value can be set with these parameters. When AR = 0, anti-reset windup functions automatically. When AR = 50.0 to 200.0%, the point at which the output is removed from the saturation state and PID, computation is restarted and is set in the deviation width. The deviation width is given by the following equation.

$$\text{Deviation width (AR)} = [\text{process variable (PV)} - \text{target setpoint value (SP)}] \\ \text{P (proportional band)} \times 100$$

**ZON** - Zone PID selection: 0: Zone PID is not used. 1: Zone PID is used. When ZON = 0, the PID parameters are changed according to the target setpoint number. When ZON = 1, the PID parameter group is automatically changed according to process variable and preprogrammed switchover reference points.

**RMD** - Operation After Recovering from Power Failure:

Restart parameters R.MD	Operation type
0	Continues the operation as it did before the power failure
1	Starts in the MAN (manual operation) mode after power recovery. Control output conforms to preset output value (PO)
2	Continues the operation as it did before the power failure. Control output conforms to preset output value (PO)

**RTM** - The restart timer for joint operation can set the time interval from when the power is turned on until start of the control operation. When joint operation is performed using the controller as an auxiliary unit, a smooth startup can be obtained by providing a timer difference between the auxiliary unit and main unit. The actual start time of the control operation is the sum of the controller's initial process time, approximately 5 seconds, and the restart timer total value. Restart timer R.TM: 0 to 10 seconds.

## 10) Analog Input Parameters

- A) Press (DISP), (^) twice CMPL (common parameter SETUP main menu)
- B) Press (SET/ENT) AIN (analog input SETUP sub menu)
- C) Press (SET/ENT) and specify ABS1 ~ AFL1 ~ ASR1 ~ ALC1 ~ ABS2 ~ AFL2 ~ ASR2 ~ ALC2 ~ ABS3 ~ AFL3 ~ ASR3 ~ ALC3

	Symbol	Description	(4) Setting range	Factory setting	CS #
AIN	ABS1	A1 bias	EUS (-100.0 to 100.0%)	EUS (0.0%)	1001
	AFL1	A1 filter	OFF, 1 to 120 seconds	OFF	1002
	ASR1	A1 square root calculation	OFF, ON	OFF	1003
	ALC1	A1 low cut	0.0 to 5.0%	1.0%	1004
	ABS2	A2 bias	EUS (-100.0 to 100.0%)	EUS(0.0%)	1005
	AFL2	A2 filter	OFF, 1 to 120 seconds	OFF	1006
	ASR2	A2 square root calculation	OFF,ON	OFF	1007
	ALC2	A2 low cut	0.0 to 5.0%	1.0%	1008
	ABS3	A3 bias	EUS (-100.0 to 100.0%)	EUS(0.0%)	1009
	AFL3	A3 filter	OFF, 1 to 120 seconds	OFF	1010
	ASR3	A3 square root calculation	OFF, ON	OFF	1011
	ALC3	A3 low cut	0.0 to 5.0%	1.0	1012

**ABS** - Analog Input Bias: Bias can be added to the pre-computation process variable input within the setpoint range.

**AFL** - Analog Input Filter: When the process variable input contains a flow rate signal, pressure signal, or other high-frequency noise, this filter can be used to eliminate the noise. The input filter is a first-order lag computation. The larger the time constant, the greater the noise reduction function.

**ASR** - Square Foot Computation: When the flow rate is measured with a flowmeter equipped with an orifice, nozzle, or other restrictions, the differential pressure signal (voltage input) can be changed to a flow rate signal with square-root computation. The low-cut point can also be set.

**ALC** - Low-cut filter: Set the low-cut point 0~5%

# 11) Retransmission Parameters

- A) Press (^) RET (retransmission SETUP sub menu)
- B) Press (SET/ENT) and specify RET1 ~ RTH1 ~ RTL1 ~ RET2 ~ RTH ~ RTL2

CS #

RET1	Send output 1 selections	1: PV1, 2: SP1, 3: OUT1 4: LPS (sensor power supply), 5: PV2 6: SP2, 7: OUT2	1	1013
RTH1	Send output 1 maximum value	EU (0.0 to 100.0%) Where, RT1L < RT1H Only when the RET number = 1, 2, 5, or 6 RET= 1, 2: Display set using PV1 range RET= 5,6: Display set using PV2 range	PRH1	1014
RTL1	Send output 1 minimum value		PRL1	1015
RET2	Transmission output 2 selection	1: PV1, 2:SP1, 3: OUT1 4: LPS (sensor power supply), 5: PV2, 6: SP2, 7: OUT2	2	1016
RTH2	Send output 2 maximum value	EU (0.0 to 100.0%) Where, RT1L < RT1H Only when the RET number = 1, 2, 5, or 6 RET= 1, 2: Display set using PV1 range RET= 5, 6: Display set using PV2 range	PRH2	1017
RTL2	Send output 2 minimum value		PRL2	1018

**RET** - Retransmission output: Retransmit the process variable, target setpoint, and other data as analog current signals (0 to 20 mA or 4 to 20 mA). 1 or 2 retransmission output points are available depending on the controller model.

- 1 = Process variable 1 PV 1
- 2 = Target setpoint 1 SP
- 3 = Control output 1 OUT 1
- 4 = Used as power source for sensors, instead of retransmission output.
- 5 = Process variable 2 PV2 (can be designated in the UT mode.)
- 6 = Target setpoint 2 SP2 (can be designated in the UT mode.)
- 7 = Control output 2 OUT 2 (can be designated in the UT mode.)

**RTH** - Retransmission output high limit.

**RTL** - Retransmission output low limit: When retransmission output is set in PV1, SP1, PV2, or SP2, the high limit of the transmission range (20mA output) is scaled as RTH, and the low limit (0 to 4 mA output) as RTL. Make sure the transmission range is set so that it does not exceed the process variable range.

## 12) Deviation Display

- A) Press (^) TRND (DV trend set, SETUP sub menu)
- B) Press (SET/ENT) and specify DVB1 ~ DVB2 ~ TSC1 ~ TSC2 ~ TTM

	Symbol	Description	Setting range	Factory setting	CS #
TRND	DVB1	Loop 1 deviation display range	EUS (0 to 100%)	EUS (1%)	1019
	DVB2	Loop 2 deviation display range	EUS (0 to 100%)	EUS (1%)	1020
	TSC1	Loop 1 deviation trend screen trend scale	EUS (1 to 100%)	EUS (5%)	1021
	TSC2	Loop 2 deviation trend screen trend scale	EUS (1 to 100%)	EUS (5%)	1022
	TTM	Deviation trend screen trend time	1 to 600 (seconds)	5 (seconds)	1023

**DVB** - Deviation Band: The Deviation Trend Lamp (located in the upper left corner of the instruments display) will light red if the PV reaches the value of SP plus the value entered in DVB.

**TSC** - Trend Scale: This value sets the vertical axis of the trend display.

**TTM** - Trend Scan Time: Set the scan time (0~600 sec.) to update the trend display.

## 13) Lockout Parameters

- A) Press (^) LOCK (key & menu lock, SETUP sub menu)  
 B) Press (SET/ENT) and specify A/M ~ MODE ~ LP1 ~ LP2 ~ PID ~ USR ~ PYS1 ~ PYS2 ~ PWD

	Symbol	Description	Setting range	Factory setting	CS #
LOCK	Δ,∇	Data setting key lock	OFF,ON	OFF	1024
	A/M	Loop 1 A/M key lock	OFF,ON	OFF	1025
	MODE	MODE screen lock	OFF,ON	OFF	1028
	LP1	LP1 screen lock	OFF,ON	OFF	1030
	LP2	LP2 screen lock	OFF,ON	ON	1031
	PID	PID screen lock	OFF,ON	OFF	1032
	USR	USR screen lock	OFF,ON	ON	1033
	PYS1	Ten-segment Linearizer 1 (PYS1) screen lock	OFF,ON	OFF	1034
	PYS2	Ten-segment Linearizer 2 (PYS2) screen lock	OFF,ON	ON	1035
	PWD	Password setting	OFF, 1 TO 30000	OFF	N/A

**LOCK** - Lock: One of two security measures - prevents unauthorized manipulation of selected keys/menus.

**PWD** - Password: One of two security measures - prevents unauthorized manipulation of selected menus.

## 14) Custom Select Display

- A) Press (DISP), (^) CONF (user configuration SETUP main menu)  
 B) Press (SET/ENT) CSEL (select display set, SETUP sub menu)  
 C) Press (SET/ENT) and specify C.S1 ~ C.S2 ~ C.S3 ~ C.S4 ~ C.S5

	Symbol	Description	Setting range	Factory setting
C.SEL	C.S1	Select screen definition 1	· Select screen definition · Select the parameter to be displayed from the parameter screen, then register it using a D register number.	OFF
	C.S2	Select screen definition 2		OFF
	C.S3	Select screen definition 3		OFF
	C.S4	Select screen definition 4		OFF
	C.S5	Select screen definition 5	· An undefined screen is not displayed.	OFF

**C.S1~C.S5** - Custom Select Screens: Allows the operator to select the parameters (up to 5) that are changed with the most frequency. By pressing the SET/ENT key the operator can scroll through all 5 displays. To assign the operating/setup parameter displays and the order in which they are to appear refer to the “D” register table. Register numbers that are assignable: (D201 ~ 1023 or off).

# 15) Digital Outputs

- A) Press (^) DO (dry output set, SETUP sub menu)
  - B) Press (SET/ENT) and specify DO1 thru DO7. If I/O module being used specify RD151 through RD158 and RD251 through RD258 if second module being used.
- \*\*\*NOTE-Assignment of default functions vary with model type & UT Mode selected.

	Symbol	Description	Setting Range	Factory Setting
DO	DO1	DO1 Output flag definition	·DO output definition  ·Select the flag to be output, then register it using a register number.  ·An undefined output is OFF (0)	See Note below
	DO2	DO2 Output flag definition		See Note below
	DO3	DO3 Output flag definition		See Note below
	DO4	DO4 Output flag definition		See Note below
	DO5	DO5 Output flag definition		See Note below
	DO6	DO6 Output flag definition		See Note below
	DO7	DO7 Output flag definition		See Note below
	RD151	O151 Output flag definition		OFF (0)
	RD152	0152 Output flag definition		OFF (0)
	RD153	0153 Output flag definition		OFF (0)
	RD154	0154 Output flag definition		OFF (0)
	RD155	0155 Output flag definition		OFF (0)
	RD156	0156 Output flag definition		OFF (0)
	RD157	0157 Output flag definition		OFF (0)
	RD158	0158 Output flag definition		OFF (0)
	RD251	0251 Output flag definition		OFF (0)
	RD252	0252 Output flag definition		OFF (0)
	RD253	0253 Output flag definition		OFF (0)
	RD254	0254 Output flag definition		OFF (0)
	RD255	0255 Output flag definition		OFF (0)
RD256	0256 Output flag definition	OFF (0)		
RD257	0257 Output flag definition	OFF (0)		
RD258	0258 Output flag definition	OFF (0)		

Note: The initial value changes according to the set value of UTMD.

**DO** - Digital Out: (D01 ~ D07) Seven outputs standard (UT550/UT750)

**RD** - Expansion Module: (RD151 ~ RD158) Option eight additional outputs (UT750-□1 Only)

**RD** - Expansion Module: (RD251 ~ RD258) Option eight additional outputs (UT750-□1 Only)

Alarms or events can be output via the contact (DO terminal). Specify the I register number of the event to output at one of the event output flag definition parameters (DO1 ~ D08). For example, to output AUTO in an AUTO/MAN selection for the first loop via the contact, register the numeric part "1343" of D register in event output flag specification parameter DO 1.



Contact symbol	I-relay number
ALM1	5689
ALM2	5690
ALM3	5691
ALM4	5693

Other DO register values can be found in the current Green Series UT550/UT750 instruction manual on CD-ROM.

## 16) Digital Inputs

- A) Press (^) DI (digital input set, SETUP sub menu)  
 B) Press (SET/ENT) and specify A/M1 ~ A/M2 ~ R/L1 ~ R/L2 ~ S/R ~ CAS ~ AUT ~ MAN ~ SP.0 ~ SP.1 ~ SP.2 ~ SP.3 ~ DP1 ~ DP2 ~ MG1 ~ MG2 ~ MG3 ~ MG4  
 \*\*\*NOTE: Assignment of default functions vary with model type & UT Mode selected.

	Symbol	Description	Setting range	Factory setting
D1 Definition	A/M1	Loop 1 auto (1)/manual (0) switchover		See Note below
	A/M2	Loop 2 auto (1)/manual (0) switchover		See Note below
	R/L1	Loop 1 remote (1)/local (2) switchover		See Note below
	R/L2	Loop 2 remote (1)/ local (2) switchover		See Note below
	S/R	Operation stop (1)/operation (0) switchover	·Event selection definition	See Note below
	CAS	Gasket mode selection (when switched OFF→ON)	·Register the D1 number connected to the event	See Note below
	AUT	Automatic (AUTO) mode selection during cascade control (when switch OFF→ON)	·An event that is not connected is OFF	See Note below
	MAN	Manual (MAN) mode selection during cascade control (when switched OFF→ON)	DI1:5161      DI2:5162 DI3:5163      DI4:5164 DI5:5165      DI6:5166 DI7:5167	See Note below
	SP.O	Bit 0 of SP number	RDI101:5177    RDI102:5178	See Note below
	SP.1	Bit 1 of SP number	RDI103:5179    RDI104:5180	See Note below
	SP.2	Bit 2 of SP number	RDI105:5181    RDI106:5182	See Note below
	SP.3	Bit 3 of SP number	RDI107:5183    RDI108:5184	See Note below
	DP1	Operation screen interrupt display 1	RDI201:5185    RDI202:5186 RDI203:5187    RDI204:5188	See Note below
	DP2	Operation screen interrupt display 2	RDI205:5189    RDI206:5190 RDI207:5191    RDI208:5192	See Note below
	MG1	Message interrupt display 1		See Note below
	MG2	Message interrupt display 2		See Note below
	MG3	Message interrupt display 3		See Note below
MG4	Message interrupt display 4		See Note below	

### Controller Contact Symbols and I-Relay Numbers

Contact symbol	I-relay number
D11	5161
D12	5162
D13	5163
D11	5164
D15	5165
D16	5166
D17	5167

**DI** - Digital Input: The contact input function supports operation mode switching, setpoint number selection, interruption display etc. Each function works as a terminal to which it is assigned and is set to on or off. Changing the operation mode using the contact input has priority over the display-key operation. To set each function, use parameters called the I relay, that is, assign the I relay number of the contact input terminal (DI) as the parameter setpoint. The following table shows the relationship among the contact sign, actually assigned I relay number, and the corresponding connection terminal. Note that terminals DI1 ~ DI7 are allocated only for the controller contact input terminals. RDI101 ~ RDI108 are for input expansion module 1, and the contact input terminals RDI201 ~ RDI208 are for input expansion module 2.

**A/M1** - Auto Manual Loop 1: Assign I-relay number

**A/M2** - Auto Manual Loop2: Assign I-relay number.

**R/L1** - Remote Local Loop 1: Assign I-relay number

**R/L2** - Remote Local Loop 2: Assign I-relay number

**S/R** - Stop Run: Assign I-relay number

**CAS AUT or MAN mode:** Selection can be assigned to the contact input. Assign the parameters solely to different contacts. This function detects the status transition from off to on at the contact input to change to the specified status. This function does not detect the steady on or off status - only the state transition.

**SP.0 ~ SP.3** - Setpoint Number Selection: Assign I-relay number

**DP1 ~ DP2** - Operation Interruption Display: Used only with custom calculation building tool.

**MG1 ~ MG4** - Message Interruption Display: Four types of messages assigned to parameters MG1 ~ MG4 (up to 20 half-size alphanumeric characters) can be displayed on the two lines under the display if the contact input is set to on. The character strings to be displayed must be registered in "D" registers D0801 ~ D0840 using the communications tool or the optional Custom Calculation Function Building Tool.

Message 1 (MG1) can be registered with registers D0801~D0810.

Message 2 (MG2) can be registered with registers D0811~D0820.

Message 3 (MG3) can be registered with registers D0821~D0830.

Message 4 (MG4) can be registered with registers D0831~D0840.

## 17) Input Linearizers

- A) Press (^) C.PYS (linearizer unit set, SETUP sub menu)  
 B) Press (SET/ENT) and specify PY1A ~ PY1B ~ PY2A ~ PY2B

	Symbol	Description	Setting range		Factory setting
Ten-Segment Linearizer Unit C.PYS	PY1A	Ten-segment Linearizer 1 input unit	0: %	1: ABS0	12
	PY1B	Ten-segment Linearizer 1 output unit	2:ABS1	3:ABS2	13
	PY2A	Ten-segment Linearizer 2 input unit	4:ABS3	5:ABS4	14
	PY2B	Ten-segment Linearizer 2 output unit	6:EU(A1)	7:EUS(A1)	15
			8:EU(A2)	9:EUS(A2)	
			10:EU(A3)	11:EUS(A3)	
			12:EU(PV1)	13:EUS (PV1)	
			14:EU(PV2)	15:EUS (PV2)	

## 18) Mode Settings

- A) Press (SET/ENT) three seconds MODE (mode parameter, main menu)  
 B) Press (SET/ENT) and specify A/M ~ A/M2 ~ C.A.M. ~ R/L1 ~ R/L2 ~ SPN

	Symbol	Description	Setting Range	Factory setting	CS #
A/M switch	A/M switch	Loop 1 automatic operation (AUTO) /manual operation (MAN) selection	Automatic operation/manual operation	Manual operation	201
Operation mode	A/M2	Loop 2 automatic operation/Manual operation selection	Automatic operation(AUTO2)/manual operation (MAN2)	MAN2	202
	C.A.M	Cascade/automatic/manual selection	Automatic (AUTO), manual(MAN),cascade (CAS)	MAN	206
	R/L1	Loop 1 remote/local selection	Remote(REMOTE1)/local (LOCAL1)	LOCAL1	203
	R/L2	Loop 2 remote/local selection	Remote (REMOTE2)/local ((LOCAL2)	LOCAL2	204
	SPNO	Target set point value (SP) number selection	1 to 8 (common to loops 1 and 2)	1	207

**A/M switch** - Auto/Manual in loop 1 can be selected by the A/M key or by a contact input signal.

**A/M2** - Auto/Manual in loop 2 can be selected in the operating parameters or by a contact input signal.

**C.A.M.**- Cascade/Auto/Manual. Select CAS to operate in cascade control mode, output of primary loop sets the setpoint for the secondary loop. The output of the secondary loop is connected to the final control element, which performs the actual control for the cascade loop. Select AUTO to perform auto tuning in the secondary loop of a cascade control mode, once auto tuning is complete switch to CAS mode to auto tune the primary loop. Auto tuning (AT) does not display in CAS mode for the secondary loop. Select MAN to manually take control of the output while in cascade control mode - MAN1 light displays on controller. Operating modes can be changed in the operating parameters or by a contact input signal.

**R/L1 & R/L2** - Remote/Local operation for loops 1 & 2 can be selected in the operating parameters or by a contact input signal.

**SPNO** - Setpoint number 1 ~ 8 can be selected in the operating parameters or by a contact input signal.

## 19) Operating Parameters

- A) Press (^) LP1 (loop 1 parameter, main menu)
- B) Press (SET/ENT) PAR (parameter, sub menu)
- C) Press (SET/ENT) and specify AT ~ SC ~ BS ~ FL ~ UPR ~ DNR ~ RTH ~ RBS ~ RFL ~ ORB ~ ORH ~ ORL

CS #

Operating parameters for loop n = 1,2	AT	Auto tuning	OFF, 1 to 8 ( for each group) 9 (group automatic selection)	OFF	241
	SC	"SUPER" function	OFF, 1, 2, 3	OFF	242
	BS	PV bias	EUS (-100.0 to 100.0%)	EUS(0%)	243
	FL	PV filter	OFF, 1 to 120 seconds	OFF	244
	UPR	Set point value ramp-up setting	OFF,EUS (MIN to 100%)	OFF	245
	DNR	Set point value ramp-down setting	OFF,EUS (MIN to 100%)	OFF	246
	RT	Ratio setting	0.0001 to 9.999	1.000	247
	RBS	Remote bias	EUS (-100 ~ 100%)	EUS(0%)	248
	RFL	Remote input filter	OFF, 1 to 120 seconds	OFF	249
	ORB	ON/OFF rate detection range (width)	EUS, (0.0 to 100.0%)	EUS(1.0%)	250
	ORH	ON/OFF rate high limit	ORL + 1digit to 105.0%	100.0%	251
	ORL	ON/OFF rate low limit	-5.0% to ORH+1digit	0.0%	252

The symbols AT, SC, BS, FL, UPR, DNR, RT, RBS, RFL, ORB, ORH and ORL are in each loop1 and loop 2.  
2- AT: Auto Tuning

**AT** - Auto Tuning: The process by which the controller itself computes and automatically sets its own PID constants. When the auto tuning parameter is turned on, the controller temporarily acts as an ON-OFF controller. It over shoots and under shoots the setpoint three times (bumps the process) to compute the appropriate proportional band (P), integral time (I), and derivative time (D), from the system response and sets those values as its own parameter values. Caution should be exercised in process with fast response variables: i.e., pressure, flow and process in which ON/OFF switching of the control output may have an undesirable effect. If auto tuning cannot determine the PID values error code E200 will display. Auto tuning will not operate for ON/OFF control.

- 1 to 8: Turned on separately for the each of eight sets of PID parameters
- 9: Turned on for all 8 sets of PID parameters

**SC** - Super Control: The "Super" function is an overshoot-suppression function that uses fuzzy logic. Use this function in combination with auto tuning to suppress overshoot, shorten startup time and to accommodate frequent load fluctuations as well as frequent setpoint changes. When the "Super" function is on, deviation is monitored to detect the danger of overshoot. If overshoot is detected the target setpoint is automatically changed to a temporary value (secondary setpoint SSP) that is somewhat lower than the target setpoint. After the danger of overshooting has passed operation gradually returns to the original target setpoint value. SC in 2 or 3 mode suppresses PV hunting.

**BS** - Process Variable Input Bias BS:EUS (-100.0 to 100.0%). The process variable input bias is the function that adds a bias (engineering units) to the process variable input value. Whereas the analog input bias (A.BS) is mainly used to correct input sensor errors, the process variable input bias is mainly used to improve controllability.

**FL** - Process Variable Input Filter FL: off or time constant of 1 to 120 seconds. This has the same function as those of the analog input filter (A.FL). However, the analog input filter is mainly used to remove input signal noise, while the process variable input filter is mainly used to improve controllability and phase compensation. In addition, the time constant can be changed during operation.

**UPR & DNR** - Setpoint value up ramp & down ramp setting. When the target setpoint value is changed this function sets the ramp rate at a predetermined value, which avoids abrupt output changes, which leads to abrupt PV changes. The slope can be set separately for a ramp-up or ramp-down. The slope time is set in TMU units.

**RT & RBS** - Ratio & Remote Bias Setting. The UT550-□4/UT750 can add a ratio and bias to the remote setpoint value. It can, therefore, be adapted to loads distributed according to zones, air/fuel ratio control, ratio control of two flow rates, etc. etc.

Computation formula:  $SP = \text{remote setting input} \times \text{ratio} + \text{remote bias}$

Ratio RTH: 0.001 to 9.999

Remote bias RBS:EUS (-100.0 to 100.0%)

**RF** - Remote Input Filter. The input filter can be set with a first-order lag computation for the remote setpoint input. The function of is the same as that of the FL (PV filter).

Remote filter RFL: off or 1 to 120 seconds

**ORB, ORH & ORL:** The ORB (output rate detection band) is the area around the setpoint, wherein, the control is stabilized and the PV is within the ORB band, but, the moving average value of the control output deviates outside the range set in ORH (output rate high limit) and ORL (output rate low limit). The Sensor Grounding Alarm detects a decline of the insulation resistance due to sensor deterioration and triggers an alarm output that is assigned to alarm 2.

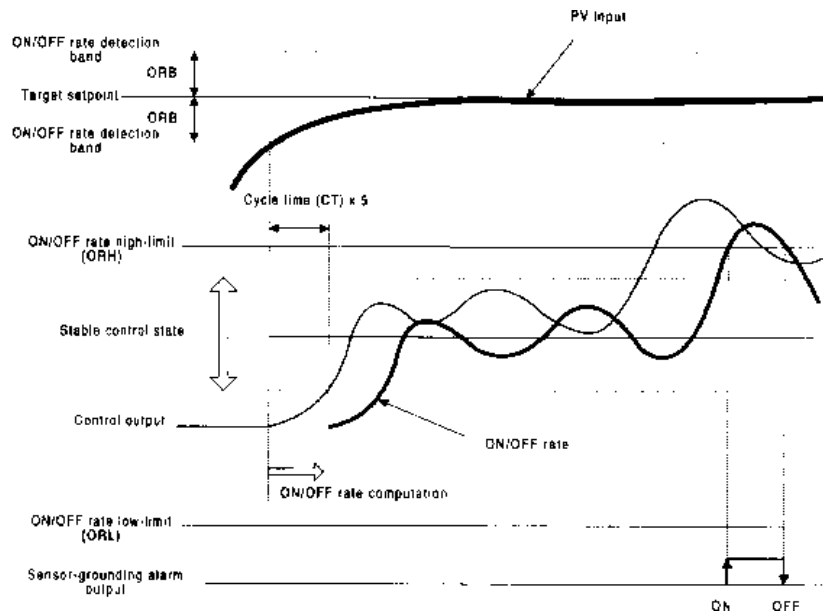

## 20) PID Parameters

- A) Press (^) 1.PID (PID parameter Spno1, sub menu)  
 B) Press (^) to set 2.PID ~ 8.PID (PID parameter Spno2~8, sub menu)  
 C) Press (SET/ENT) and specify 1.SP ~ 1.A1 ~ 1.A2 ~ 1.A3 ~ 1.A4 ~ 1.P ~ 1.I ~ 1.D ~ 1.OH ~ 1.OL ~ 1.MR ~ 1.DR ~ 1.PO ~

	Symbol	Description	Setting Range	Factory Setting	CS # - PID Set 1 See Note Below
m.PID	m.SP	Target set point value	EU (0 to 100%)	EU (0.0%)	301
	m. A1	Alarm 1 setpoint	Measurement value alarm: EU (-100 to 100%) Deviation alarm: Eus (-100 to 100%) Timer alarm: 00.00 to 99.59 [Hours and minutes or minutes and seconds]	Note 1	302
	m.A2	Alarm 2 setpoint	Same as above (excluding timer alarm)	Same as above	303
	m.A3	Alarm 3 setpoint	Same as above (excluding timer alarm)	Same as above	304
	m.A4	Alarm 4 setpoint	Same as above (excluding timer alarm)	Same as above	305
	m.P	Proportional band(P); heating side proportional control in the case of heating/cooling control	0.1 to 999.9% 0.0 to 999.9% in the case of heating/cooling control Heating side ON/OFF control in the case of 0.0, However	5.0%	306
	m.I	integral time (I); heating side integral in the case of heating/cooling control	OFF, 1 to 6000 seconds	240 seconds	307
	m.D	Derivative time (D); heating side derivative time in the case of heating/ cooling control	OFF, 1 to 6000 seconds	60 seconds	308
	m.OH	Output high-limit value; heating side output high-limit value in the case of heating/cooling control	m.OL + 1 digit to 105.0% -5.0 to 105.0% ( for heating/cooling)	100.0%	309
	m.OL	Output low-limit value; heating side output low-limit value in the case of heating/cooling control	SD, -5.0% to m. Oh-1 digit -5.0 to 105.5% (for heating/cooling)	0.0%	310
	m.MR	Manual reset; heating manual reset in the case of heating/cooling control	-5.0 to 105.0%	50.0%	311
	m.H	Hysteresis Relay hysteresis in the case of a position proportional type	EUS (0.0 to 100.0%) (ON/OFF control) 0 to 100% (position proportional PID control, heating/cooling control)	EUS (0.5%) 0.5% (position proportional, heating/cooling)	312
	m. DR	Forward/ reverse switchover	0: Reverse control, 1: Forward control	0: Reverse control	313
	m.Pc	Cooling proportional band (P)	0.0 to 999.9% Heating side ON/OFF control in the case of 0.0< however	5.0%	314
	m.Ic	Cooling integral time (I)	OFF, 1 to 6000 seconds	240 seconds	315
	m.Dc	Cooling derivative time (D)	OFF, 10 to 6000 seconds	60 seconds	316
	m.Hc	Cooling side relay hysteresis	0 to 100.0%	0.5%	317
	m.DB	Deadband	-100.0 to 50.0% 1.0 to 10.0% (heating/cooling control)	3.0%	318
m.Po	Preset output	-5.0 to 105.0%	0.0%	320	
m.Oc	Cooling side preset output	-5.0 to 105.0%	0.0%	321	

The symbol RHY belongs to PID group 7 of each loop and the symbol RDV belongs to PID group 8.

**PLEASE NOTE:** m = Setpoint number 1~8  
n = Loop number 1~2

PID Set 2 – Start with 326, Repeat Above Sequence  
PID Set 3 – Start with 351, Repeat Above Sequence  
PID Set 4 – Start with 376, Repeat Above Sequence

PID Set 5 – Start with 401, Repeat Above Sequence  
PID Set 6 – Start with 426, Repeat Above Sequence  
PID Set 7 – Start with 451, Repeat Above Sequence  
PID Set 8 – Start with 476, Repeat Above Sequence



**SP** - Setpoint number

**A1, A2, A3, A4** - Alarm 1~ 4 setpoints

Process variable alarm: EUS (-I 00 to I 00%)

Deviation alarm: EUS (- I 00 to 100%)

**P** - Proportional Band: The parameter that regulates the effectiveness of proportional action. It is defined as the amount of change in input (or deviation), as a percent of span, required to cause the control output to change from 0% to 100%. In theory, a proportional controller should be all that is needed for optimum control. However, a weakness of proportional-only control is that it requires a significant error condition to create an output signal. By narrowing the proportional band to achieve tighter control, reduce the offset, leads to poor control because of oscillation. Widening the proportional band reduces oscillation but increases the offset Reducing the proportional band to it's smallest limit, P=0%, results in ON/OFF control.

**I** - Integral Time: Defined as the time required, when a stepwise change in deviation is imposed, to develop an output change due to integral action that is exactly equal to the change due to proportional action. Integral time is set in **seconds/repeat**: the longer the integral time set, the slower the change in output; the smaller the time set, the faster the output changes. Integral (Reset) action adjusts the controller output to eliminate offset. Reset attempts to position the output as a narrower proportional band would, however, since the proportional band is fixed once selected, reset action in effect **shifts** the proportional band to increase or decrease the output. Using manual reset, the operator will shift the proportional band; using automatic reset (integral) the output is automatically increased or decreased to bring the process temperature back to setpoint.

**D** - Derivative Time: This parameter sets how the derivative action is to operate. Derivative (Rate) action, acts on error just like integral (rate action) does except rate action is a function of the rate of change rather than the magnitude of error. Rate action is applied as a change in output for a selectable time interval stated in seconds. It is the time required, when a constant-slope change in deviation is imposed, to develop an output change due to derivative action that is exactly equal to the change due to proportional action. Rate action **quickly** positions the output where proportional action alone would **eventually** position the output. If the controlled object has a large time constant or dead time, with P or PI action alone there will be cases where the response will be slow, overshoot will occur, and the control system will be unstable. In effect, rate action puts the brakes on any offset or error by quickly shifting the proportional band either up or down to compensate for rapidly changing temperature. The amount of shift is proportional to the rate of temperature change. The longer the derivative time set, the stronger the corrective action, and the more likely the output will become oscillatory.

**OH & OL**: The controller is equipped with an output limiter, and the high and low limits of the control output operating range can be set. This, however, excludes preset output during the STOP status. The output limiter setpoint value has eight settings corresponding to the target setpoints. The output limiter corresponds and is linked to the selection of the target setpoint.

Controllers with the Position Proportional Option come with the shutdown (SD) function. By setting "SD" in the output low limit (m. OL), the shutdown function is set when the MAN mode is engaged and the current output is 4 to 20 mA. The shutdown function fully closes the control valve after the control valve position passes the deadband. During AUTO operation, the low limit is -5.0% and will not drop lower than 3.2 mA. During MAN operation, if the output is reduced with the down arrow key to -5.0% the shutdown output (0.0 mA) is engaged.

**MR** - Manual Reset Value: This parameter has no effect except when integral time (I) has been set to "OFF". Using manual reset to eliminate offset (deviation), the operator increases or decreases the output to shift the proportional band. Using automatic reset (integral) the output is automatically increased or decreased to bring the process temperature back to setpoint.

**Hysteresis** - Heating-side hysteresis when in heating/cooling control and relay hysteresis when in position proportional PID control. The on/off control compares the target setpoint value and the process variable input value and outputs an on or off signal according to the positive or negative deviation. The output type is a relay output. A value set in the vicinity of the on/off operating point is referred to as hysteresis. In the case of time proportional PID output and continuous output, the hysteresis during the on/off operation is set, and with position proportional PID control, a relay hysteresis is set. If the target setpoint value and the process variable input value are closed during an on/off operation and the polarity of the deviation reverses frequently, the on/off output will output on/off repeatedly. The life of the output relay will, therefore, be dramatically shortened, especially in the case of a relay contact output.

**DR** - Direct Action/Reverse Action: The direction of an output increase or decrease according to the polarity of the deviation is defined as direct action or reverse action. Designation of direct/reverse action includes 8 settings corresponding to the setpoints (SP). This action corresponds and is linked to the selection of setpoint functions. Designation is not required in heating/cooling control.

**DB** - Dead band: This is the dead band for position proportional PID control and heating/cooling control.

**RP** - Reference point: Up to 6 reference points can be set at the changeover point when switching the PID setpoint value. The factory setting is such that the No. 1 PID setpoint value is applied to the entire process variable range.

**RHY** - Zone Switching Hysteresis: The hysteresis width can be set during the PID setpoint value changeover. This hysteresis is commonly set for all reference points.

**RDV** - Reference deviation: The method of changing over PID parameters according to the size of the deviation is called "reference deviation changeover." As the deviation becomes larger than the reference deviation setpoint value during execution of fixed-point control, it switches over to the previously set PID setpoint value in PID set 8. For example, if the deviation is large the proportional gain increases (the proportional band becomes smaller) and the target setpoint can be quickly reached. This function is given priority over the PID setting based on the reference point. The reference deviation is set with operating parameter RD.

**PO** - Preset Output: This is the control output value when the controller switches the operating modes from RUN to STOP. The preset output value is not limited by either the output high and low limits, or, the output velocity limit. The return from STOP to RUN is bumpless; in heating/cooling control, however, both heating and cooling control starts at the 50% output value.

## 21) User Parameters

- A) Press (DISP) then (^) USR (user parameter, main menu)  
 B) Press (SET/ENT) and specify U1 ~ U8

	Symbol	Description	Setting range	Factory setting	CA #
USR	U1	User operating parameter 1	EU specification: EU (-5.0 to 105.0%) EUS specifications: EUS (-5.0 to 105.0%) % specification: -19999 to 32000 ABS0 specification: -19999 to 32000 ABS1 specification: -1999.9 to 3200.0 ABS2 specification: -199.99 to 320.00 ABS3 specification: -199.999 to 32.000 ABS4 specifications: -1.9999 to 3.2000 For ABS, the span excluding the decimal point is 30000 or less.	Registered using a Compound Calculation Function Configuring tool	701
	U2	User operating parameter 2			702
	U3	User operating parameter 3			703
	U4	User operating parameter 4			704
	U5	User operating parameter 5			705
	U6	User operating parameter 6			706
	U7	User operating parameter 7			707
	U8	User operating parameter 8			708

**USR** - User operating parameters: U1 to U8 listed above are displayed when:

- (1) The UT Mode is set to 6 or 14 for PV input switching or 7 or 15 for PC auto selector.
- (2) A custom-computation generation tool is used. The UT mode is set to 21 for custom computation control.

User parameters are parameters that can be freely used for data setting in **CUSTOM COMPUTATION**. They include U1 to U8 and are assigned to 701 to 708 of the D-register. Set the default values, units, and guidance that is displayed on the controller display. The guidance consists of up to 21 characters. When the controller executes parameter initialization, they are set to these values.

## 22) Set Input Linearizer

- A) Press (DISP) then (^) PYS1 (linearizer 1 para., main menu)  
 B) Press (SET/ENT) and specify 1.a1, 1.b1 ~ 1.a11, 1b11 and 1.PMD  
 \*\*\* If dual input press (^) & repeat steps 22 for loop 2.

PY Sn	n.a1	Ten-segment Linearizer input 1	a.a1 to n.a1 1 os defined by PY1A Where, n.a1 < n.a2 n.b1 to n.b 1 1 is defined by PY1B EU specification: EU (-5.0 to 105.0%) EUS specification: EUS (-5.0 to 105.0%) % specification: m-5.0 to 105.0% ABS0 specification: -19999 to 32000 ABS1 specification: -1999.9 to 3200.00 ABS2 specification: -199.99 to 320.0 ABS3 specification: -19.999 to 32.000 ABS4 specification: -1.9999 to 3.2000 For ABS, the span excluding the decimal point is 30000 or less.	EU(0.0%)
	n.b1	Ten-segment Linearizer output 1		EUS(0.0%)
	n.a2	Ten-segment Linearizer input 2		EU(0.0%)
	n.b2	Ten-segment Linearizer output 2		EUS(0.0%)
	n.a3	Ten-segment Linearizer input 3		EU(0.0%)
	n.b3	Ten-segment Linearizer output 3		EUS(0.0%)
	n.a4	Ten-segment Linearizer input 4		EU(0.0%)
	n.b4	Ten-segment Linearizer output 4		EUS(0.0%)0
	n.a5	Ten-segment Linearizer input 5		EU(0.0%)
	n.b5	Ten-segment Linearizer output 5		EUS(0.0%)
	n.a6	Ten-segment Linearizer input 6		EU(0.0%)
	n.b6	Ten-segment Linearizer output 6		EUS(0.0%)0
	n.a7	Ten-segment Linearizer input 7		EU(0.0%)
	n.b7	Ten-segment Linearizer output 7		EUS(0.0%)
n.a8	Ten-segment Linearizer input 8	EU(0.0%)		
n.b8	Ten-segment Linearizer output 8	EUS(0.0%)		
n.a9	Ten-segment Linearizer input 9	EU(0.0%)		
n.b9	Ten-segment Linearizer output 9	EUS(0.0%)		
n.a10	Ten-segment Linearizer input 10	EU(0.0%)		
n.b10	Ten-segment Linearizer output 10	EUS(0.0%)		
n.a11	Ten-segment Linearizer input 11	EU(0.0%)		
n.b11	Ten-segment Linearizer output 11	EUS(0.0%)0		
	n.PMD	Ten-segment Linearizer mode	0: Line-segment bias 1: Line-segment	0

If the input signal and a signal to be measured do not have a linear relationship, i.e. volume and water level of a spherical tank, a ten segment linearizer can be used to obtain the volume process variable signal. Up to 10 line segments can be freely set for line-point input or output of the line-segment linearizer. The linearizer has a 2-set function. Line-segment input a1~ a11 and line-segment output b1~ b11.

**PMD - Ten Segment Linearizer Mode:** Can be set either to carry out line-segment linearizer or line-segment bias. The line-segment bias consists of the process variable input value and the value of the line-segment linearizer function.

## Appendix A - LED Alphanumeric Characters

Some figures shown in this manual may be emphasized, simplified, or partially omitted for reasons of convenience in explaining them.

### LED alphanumeric characters

Alphabet character	LED display	Alphabet character	LED display	Numeric character	LED display
A	A	N	n	1	1
B	b	O	o	2	2
C (uppercase) c (lowercase)	C, c	P	p	3	3
D	d	Q	q	4	4
E	E	R	r	5	5
F	F	S	S	6	6
G	G	T	t	7	7
H	H	U	U	8	8
I	I	V	V	9	9
J	J	W	W	0	0
K	K	X	X (None)	-	-
L	L	Y	Y	°C	°C
M	M	Z	Z	°F	°F
				%	%

## Appendix B - Errors at Power-on

These errors may be caused during self-diagnosis following a power-on:

**Table C1-1 Errors at Power-on**

Error display	Cause	Controller status	PV	Control output	Alarm output	Retransmission	Communication	Handling
E000	RAM failure	Operation suspended	None	0% or less, or OFF	OFF	0% or less	Stopped	Repairing required
E001	ROM failure							
E002	System data error	Output suspended	None	0% or OFF	None	None	Normal	Repairing required
PV decimal point blinks	Calibration failure	Normalized after calibration initialization	Normal but inaccurate	Normal but inaccurate	Normal but inaccurate	Normal but inaccurate	Normal	Repairing required

## Appendix C - Operating Errors

These errors may be caused during operation:

**Table C1-2 Errors during Operation**

Error display	Cause	Controller status	PV input	Control output	Alarm output	Retransmission	Communication	Handling
"RJC" and PV shown alternately	RJC failure (loop-1 only)	Only RJC suspended	Measured as RJC=0	Normal	Normal	Normal	Normal	Repairing required
Blinking dot on SP display	EEPROM error	Normal but only RAM used until power down	Normal	Normal	Normal	Normal	Normal	
E300	ADC failure	Normal but auto-tuning terminated	105%	Preset output in AUTO, normal in MAN.	Normal	Normal	Normal	
B.OUT	PV burnout (loop 1, 2 respectively*)	Dependent on BSL setting	Value set as BSL		Normal	Normal	Normal	Check wiring and sensor
OVER or -OVER	PV out of range (other value than -5 through 105%, (loop 1, 2 respectively*))	Operated at PV=105% or -5%	Limit value.	Normal	Normal	Normal	Normal	Check the process
E200	Auto-tuning failure (time-out) (loop 1, 2 respectively*)	Operated at PID prior to auto-tuning execution	Normal	Normal	Normal	Normal	Normal	Check the process. Press any key to clear error display.
Blinking dot on SP display	Communication circuit failure	Error message returned	Normal	Normal	Normal	Normal	Normal	Check wiring, Check and re-set communication parameter for recovery.
None	Communication time-out	Standby	Normal	Normal	Normal	Normal	Normal	Check if delimiter is transmitted.
None	Communication syntax error	Error message returned	Normal	Normal	Normal	Normal	Normal	Check transmission data.
Blinking dot on PV display	Collapse due to power irregularity or noise	CPU reset	Undefined	0% or less, or OFF	OFF	0% or less	Stopped	Repairing required if not restarted by power OFF and ON.
All displays out	Power down (see Part C, 1.2)	No power supplied	None	0% or less, or OFF	OFF	0% or less	Stopped	Check power supply.

\*Note: The error condition is applied only to the loop in which the error is caused.

## Appendix D – Hardware Specifications

### Hardware Specifications

#### I/O signals

##### Measurement input signals

- Number of inputs: 1.
- Type, instrument range: See Table below. Selectable using parameters.
- Measured input accuracy: See Table below.
- Burnout detection: Available with the following input, thermocouple, resistance temperature detector and standard signal input of 0.4-2V, 1-5V. 0.1V and below input will be detected as a burnout with standard signal input. Selectable among up scale, down scale, and OFF.

**Table A1-1 Instrument Input Range Code and Range**

Input type		Input range code	Instrument input range	Measurement accuracy
Thermocouple	K	1	-270.0-1370.0°C	0°C & over: $\pm 0.1\% \pm 1$ digit of range. Below 0°C: $\pm 0.2\% \pm 1$ digit of range. Below 200°C: No guaranteed accuracy.
		2	-270.0-1000.0°C	
		3	-270.0-500.0°C	
	J	4	-200.0-1200.0°C	
	T	5	-270.0-400.0°C	
		6	0.0-400.0°C	
	B	7	0.0-1800.0°C	Over 400°C: $\pm 0.15\% \pm 1$ digit of range. Below 400°C: $\pm 5\% \pm 1$ digit of range.
	S	8	0.0-1700.0°C	$\pm 0.15\% \pm 1$ digit of range.
	R	9	0.0-1700.0°C	
	N	10	-270.0-1300.0°C	$\pm 0.1\% \pm 1$ digit of range. Below 200°C: No guaranteed accuracy.
	E	11	-270.0-1000.0°C	0°C & over: $\pm 0.1\% \pm 1$ digit of range. Below 0°C: $\pm 0.2\% \pm 1$ digit of range. Below 200°C: No guaranteed accuracy.
	L	12	-200.0-900.0°C	
	U	13	-200.0-400.0°C	
		14	0.0-400.0°C	
	W	15	0.0-2300.0°C	$\pm 0.2\% \pm 1$ digit of range.
Platinel 2	16	0.0-1390.0°C	$\pm 0.1\% \pm 1$ digit of range.	
PR20-40	17	0.0-1900.0°C	800°C & over: $\pm 0.15\% \pm 1$ digit of range. Below 800°C: $\pm 5\% \pm 1$ digit of range.	
W97Re3-W75Re25	18	0.0-2000.0°C	$\pm 0.2\% \pm 1$ digit of range.	
Resistance temperature detector	JPt100	30	-200.0-500.0°C	$\pm 0.1\% \pm 1$ digit of range.
		31	-150.00-150.00°C	$\pm 0.2\% \pm 1$ digit of range.
	Pt100	35	-200.0-640.0°C	$\pm 0.1\% \pm 1$ digit of range.
		36	-200.0-500.0°C	
		37	-150.00-150.00°C	$\pm 0.2\% \pm 1$ digit of range.
Standard signal	0.4-2V	40	0.400-2.000	Displayed range: -19999-32000 Displayed span: Within 30000 $\pm 0.1\% \pm 1$ digit of range.
	1-5V	41	1.000-5.000	
DC voltage (V)	0-2V	50	0.000-2.000	
	0-10V	51	0.00-10.00	
DC voltage (mV)	-10-20mV	55	-10.00-20.00	
	0-100mV	56	0.0-100.0	



Input bias current:	0.05 $\mu$ A for thermocouple and resistance temperature detector (b-terminal) input.
Input resistance:	Over 1M $\Omega$ for thermocouple/DC voltage (mV) input. Approximately 1M $\Omega$ for standard signal and DC voltage (V) inputs.
Allowable signal-source resistance:	Below 250 $\Omega$ with a resistance influence of below 0.1 $\mu$ V/ $\Omega$ for thermocouple/DC voltage (mV) input. Below 2k $\Omega$ with a resistance influence of approximately 0.01%/100 $\Omega$ for standard signal and DC voltage (V) input.
Allowable wiring resistance:	Max. 150 $\Omega$ /wire for resistance temperature detector input, with conductor resistance equal among 3 wires. 10 $\Omega$ /wire for a range of – 150.0 through 150.0 $^{\circ}$ C. Resistance influence: $\pm$ 0.1 $^{\circ}$ C/10 $\Omega$ .
Allowable input voltage:	$\pm$ 10VDC for thermocouple/mV/resistance temperature detector input $\pm$ 20VDC for standard signal and DC voltage (V) input.
Noise rejection ratio:	Over 40dB (50/60Hz) in normal mode, or over 120dB (50/60Hz) in common mode.
Reference junction compensation error:	$\pm$ 1.0 $^{\circ}$ C (15-35 $^{\circ}$ C), $\pm$ 1.5 $^{\circ}$ C (0-15 $^{\circ}$ C, 15-50 $^{\circ}$ C).
Applied standards:	JIS, IEC, and DIN for thermocouples and resistance temperature detectors.

#### Auxiliary analog input signals (UT550-x1, -x2, and -x4; UT520-07, and -08 only)

Functions:	Used for remote setpoint input, tracking input, cascade secondary-loop measurement input, etc.
Input types:	Selectable in DC voltage input ranges of 0.4-2.0V, 1-5V, 0-2V or 0-10V.
Number of inputs:	1.
Sampling period:	100 mS.
Input resistance:	Approx. 1M $\Omega$ .
Input accuracy:	$\pm$ 0.3% $\pm$ 1 digit of span for 0-2VDC input, or $\pm$ 0.2% $\pm$ 1 digit of span for 0-10VDC input.

#### Feedback resistance input signals

Available with UT550-1x model only and effective for position-proportional PID control.	
Slide resistance range:	100 through 2.5k $\Omega$ (with sliding wire burnout detection).
Measurement resolution:	$\pm$ 0.1% of slide resistance.

#### Sensor power supply output

Supplies power to a 2-wire transmitter. Either this or retransmission output can be used selectively using the same terminals. Equipped with a field short-circuit guard circuit.	
Supply voltage:	14.5 to 18.0VDC.
Max. current:	Approx. 21mA.

#### Retransmission output

Used to output measured values, target setpoints, or control output values. Either this or sensor power supply output can be used selectively using the same terminals.	
Number of outputs:	1 or 2 (only one is available when current or voltage pulse output is used for control output or heating-line control output).
Output signals:	4-20mADC, 0-20mADC, 20-4mADC, or 20-0mADC (signals below 0mADC cannot be output).
Load resistance:	Below 600 $\Omega$ .
Output accuracy:	$\pm$ 0.1% of span ( $\pm$ 5% of span for signals below 1mADC).

### Control outputs

One or two outputs can be selected from the following output types depending on the controller's model code and UT mode setup. (Two outputs can be selected only for UT550-2x model. Relay contact output is used for a position-proportional PID model UT550-1x.)

### Current output:

Number of outputs: 1 or 2 (switched with voltage pulse output).  
Output signals: 4-20mADC, 0-20mADC, 20-4mADC, or 20-0mADC.  
Load resistance: Below 600Ω.  
Output accuracy: ±0.1% of span (±5% of span for signals below 1mADC).

### Voltage pulse output:

Number of outputs: 1 or 2 (switched with current output).  
Output signals: Over 12V for ON voltage (over 600Ω load). Below 0.1VDC for OFF voltage.  
Resolution: 10 or 0.1% of output, whichever is larger.

### Relay contact output:

Number of outputs: 1 or 2.  
Output signals: NC, NO, and common terminals.  
Contact rating: 250VAC, 3A; or 30VDC, 3A (resistance load).  
Resolution: 10ms or 0.1% of output, whichever is larger.

### Contact inputs (DI)

Used for the switching of target setpoints, C/A/M modes, R/L modes, S/R modes, front-panel key-lock/unlock, PV inputs.

Number of inputs: Varies according to optional specifications as follows:  
UT550-x0: 2, UT550-x1: 8, UT550-x2: 3, UT550-x3: 7, UT550-x4: 3, UT520-x0: 2, UT520-07: 4, UT520-08: 4.  
Input type: Non-voltage contact or transistor open collector.  
Input contact capacity: 12VDC, over 10mA.  
ON/OFF switching: For contact input, ON when contact resistance is below 1kΩ and OFF when it is over 20kΩ. For transistor input, ON when voltage is below 2V and OFF when leak current is below 100μA.  
Minimum status detection hold time: 400ms

### Contact outputs (DO)

Used for alarm and FAIL outputs.

Number of outputs: Varies according to optional specifications as follows:  
UT550-x0: 3 relay outputs, UT550-x1: 3 relay outputs and 4 transistor open collector outputs, UT550-x2: 3 relay outputs, UT550-x3: 3 relay outputs and 4 transistor open collector outputs, UT550-x4: 3 relay outputs; UT520-0x: 3 relay outputs.  
A control output relay is applicable as alarm-4 contact output relay if not used for control output. Thus every controller shown above may be provided with 4 relay outputs instead of 3.  
Relay contact rating: 240VAC, 1A; or 30VDC, 1A.  
Transistor contact rating: 24VDC, 50mA.

Note: Any equipment connected to the controller's contact terminals must comply with the IEC1010 or 950 standard.

### Displays

PV display: Uses 7-segment red LEDs for 5-digit display of measured process variable input, having a displayed character height of 20mm (UT550) or 12mm (UT520).  
Setpoint display: Uses 7-segment red LEDs for 4-digit display of setpoints, having a displayed character height of 9.3mm (UT550/520).  
Status indicator lamps: Yellow and green LEDs.

### Safety and EMC Standards

Safety standards: IEC1010-1-1990 and EN61010-1-1992; CSA1010 CAT II (IEC1010-1); and UL508.  
EMC standards: EN55011 Class A, Group 1, for emission (EMI); and EN50082-2-1995 for immunity (EMS).

### Power Unit and Isolation

Power supply voltage rating: 100-240VAC ( $\pm 10\%$ ), 50/60Hz.  
Power consumption: Max. 20VA, 8.0W.  
Fuse rating: 250VAC, 1.6A, time-lag fuse.  
Data memory: EEPROM, good for approx. 100,000 data entries.  
Withstand voltage: 2300VC for 1 min. between primary and secondary or grounding terminals. 1500VAC for 1 min. between secondary and grounding terminals. 500VAC for 1 min. between two secondary terminals. (Primary terminals: Power and relay output terminals. Secondary terminals: analog I/O signal, voltage pulse output, and contact input terminals.)  
Insulation resistance: Over 500VDC, 20M $\Omega$ , between power and grounding terminals.  
Grounding: Class 3.  
Circuit-breaker rating: Use a 5A circuit breaker (100 to 240V, AC) in compliance with IEC947-1 or IEC947-3. Installation in the same room as the controller is recommended.  
Isolation: Terminal inputs and outputs are isolated as shown in the figure below (terminals distinguished by thick lines in the figure are functionally isolated terminals).

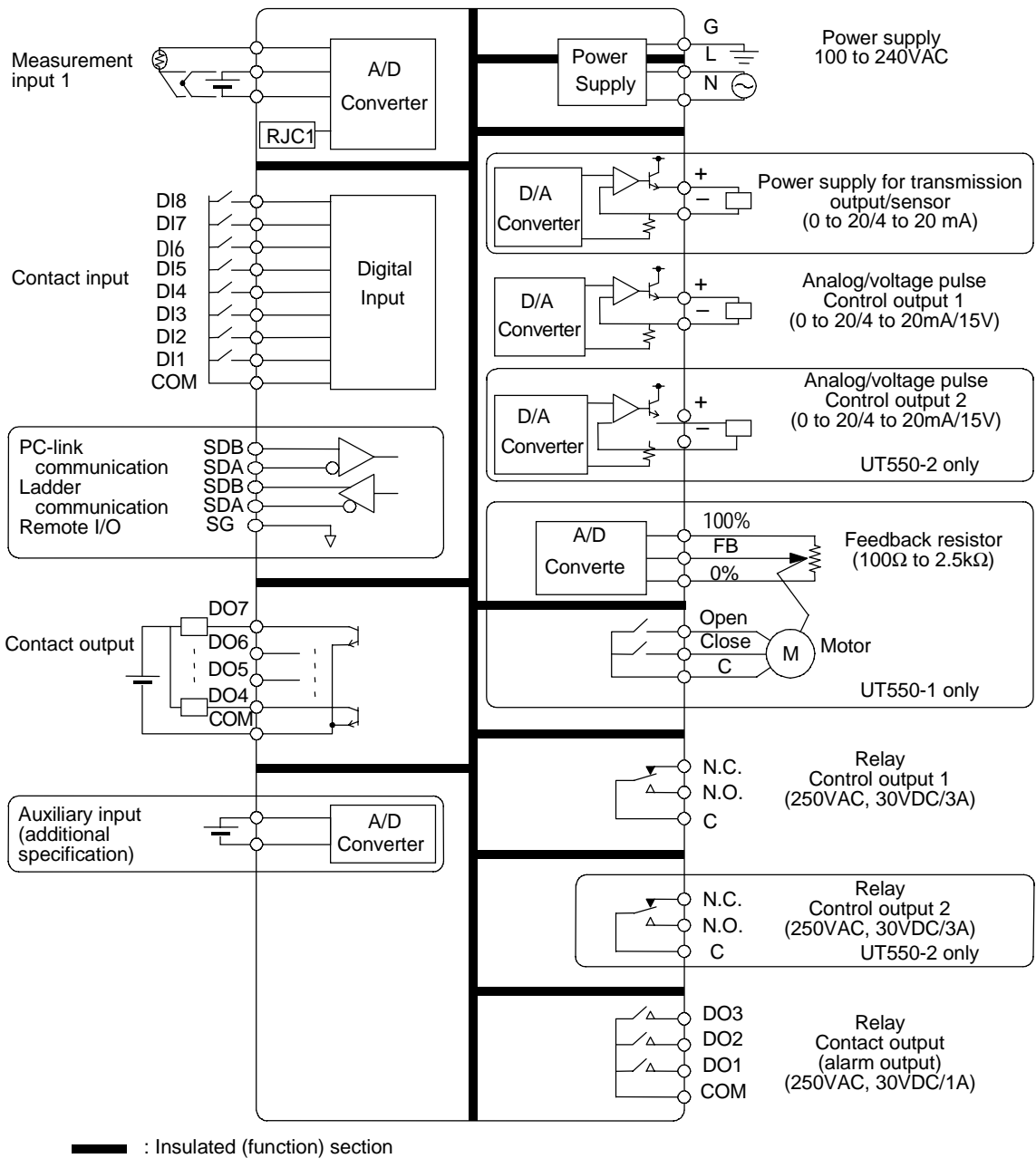

Figure A1-1 Isolation



IMPORTANT

Power and relay contact output circuits are reinforced-insulated from other circuits.

Table A1-2 Isolation Specifications

Terminal	Isolation
PV input	Insulated from other I/O terminals. Not insulated from internal circuits.
Aux. analog input	Insulated from other I/O terminals and internal circuits.
Sensor power supply	Insulated from other I/O terminals and internal circuits. Not insulated from 4-20mA analog and voltage pulse control output terminals.
4-20mA analog output (control, retransmission)	Insulated from other I/O terminals and internal circuits. Not insulated between 4-20mA output terminals and from sensor power supply and voltage pulse control output terminals.
Voltage pulse control output	Insulated from other I/O terminals and internal circuits. Not insulated from 4-20mA output, sensor power supply terminals.
Relay contact control output	Insulated between contact output terminals and from other I/O terminals and internal circuits.
Contact input	Insulated from other I/O terminals and internal circuits. Not insulated between contact input terminals and from communication terminal.
Relay contact alarm output	Insulated from other I/O terminals and internal circuits. Not insulated between relay contact alarm output terminals.
Transistor contact alarm output	Insulated from other I/O terminals and internal circuits. Not insulated between transistor contact alarm output terminals.
RS485 communication	Insulated from other I/O terminals and internal circuits. Not insulated from contact input terminals.
Feedback slide resistance input	Insulated from other I/O terminals and internal circuits. Not insulated from 4-20mA analog output (control, retransmission), sensor power supply, and voltage pulse control output terminals.
Power supply	Insulated from other I/O terminals and internal circuits.
Grounding	Insulated from other I/O terminals and internal circuits.

**Ambience**

Installation conditions (for normal operation)

Ambient temperature: 0-50°C (max. 40°C, fluctuation below 10°C/h, for side-by-side installation).

Ambient humidity: 20-90%RH without dew condensation.

Location: Indoor.

Magnetic field: Below 400AT/m.

Continuous vibration: 5-14Hz, total amplitude: up to 1.2mm.

Continuous vibration: 14-150Hz, up to 4.9m/s<sup>2</sup> (0.5G).

Short-time vibration: 14.7m/s<sup>2</sup> (1.5G) up to 15s.

Impact: 147m/s<sup>2</sup> (15G) up to 11ms.

Altitude: Up to 2,000m.

Attitude: Max. 30 degrees facing upward. Not designed for installation facing downward.

IEC1010 installation category:

II (impulse withstand voltage regulation for electrical equipment, also called 'over voltage category').

IEC1010 pollution level: 2 (level of solid, liquid, gas, or other foreign substance adhesion degrading dielectric strength; level 2 rules ordinary indoor ambience).

Transportation and storage:

-25 to 70°C, 5 to 95%RH without dew condensation.

Ambient operating conditions (influence of ambient temperature):

Voltage and thermocouple input:  $\pm 1\mu\text{V}/^\circ\text{C}$  or  $\pm 0.01\%$  of FS/ $^\circ\text{C}$ , whichever is larger.  
Resistance temperature detector input: Up to  $\pm 0.05^\circ\text{C}/^\circ\text{C}$ .  
Analog output: Up to  $\pm 0.05\%$  of FS/ $^\circ\text{C}$ .

Ambient operating conditions (influence to power fluctuation within rated voltage):

Analog input:  $\pm 1\mu\text{V}/10\text{V}$  or  $\pm 0.01\%$  of FS/10V, whichever is larger.  
Analog output: Up to  $\pm 0.05\%$  of FS/10V.

## Appendix E - Installation

---

This Chapter describes precautions and procedures for the installation of the UT550/520 digital-indicating controller.

### E.1 Location

---



#### CAUTION

---

---

Be sure to operate the controller installed on a panel to prevent electric shock.

---

---



#### NOTE

---

---

To install the controller, select a location where:

- (1) no one may accidentally touch the terminals,
  - (2) mechanical vibrations are minimal,
  - (3) no corrosive gas is present,
  - (4) temperature can be maintained at about 23°C and the fluctuation is minimal,
  - (5) no direct heat radiation is present,
  - (6) no magnetic disturbances are caused,
  - (7) no water is splashed,
  - (8) no flammable materials are around,
  - (9) no wind blows against the terminal board (reference junction compensation element, etc.)
- 
- 

The housing of the controller is made of flame-retarded polycarbonate resin and the bezels are of flame-retarded ABS resin, however, be sure to keep the controller away from any easily flammable items or equipment.

If the controller has to be installed close to some easily flammable items or equipment, be sure to provide shielding panels all around the controller, at least 150mm away from every side; the panels can be plates 1.43mm-thick steel plates or uncoated 1.6mm-thick steel plates.

## E.2 External Dimensions

### 2.2.1 External Dimensions

Figure A2-1 UT550 and UT750 External Dimensions

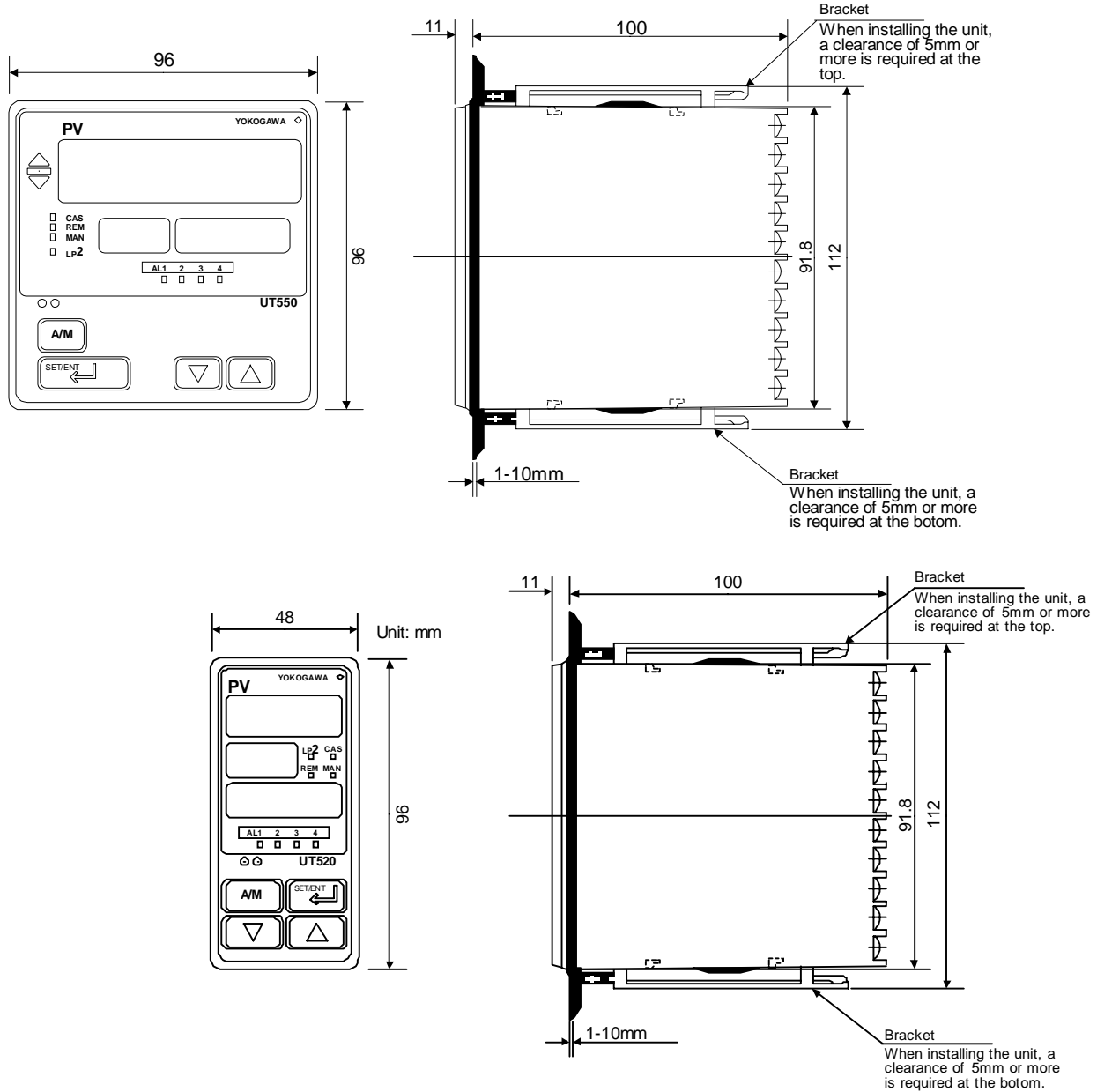

Figure A2-2 UT520 External Dimensions



2.2.2

Panel Cutout Dimensions

Use a 1 to 10mm-thick steel plate as the panel to mount the controller.

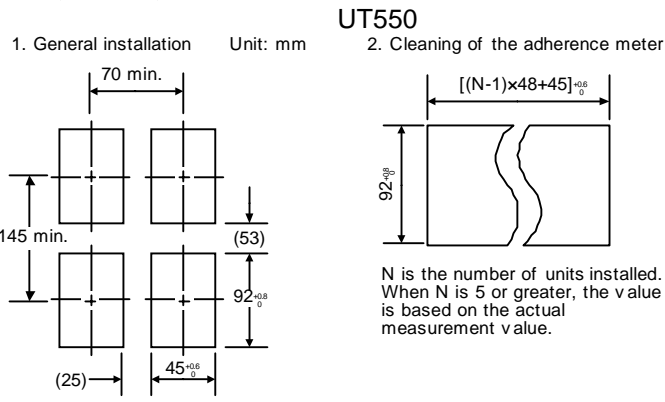
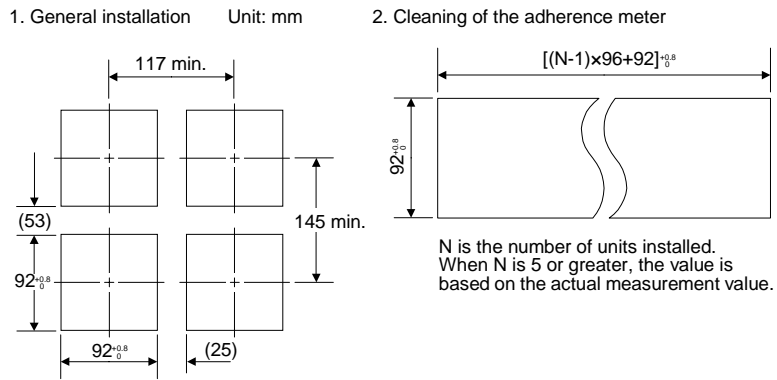

UT520

Figure A2-3 Panel Cutout Dimensions

## E.3 Mounting

Mount the controller in the panel as shown in Figure A2-4 and described below. Both UT550 and UT520 controllers can be mounted in the same manner although their brackets are slightly different.

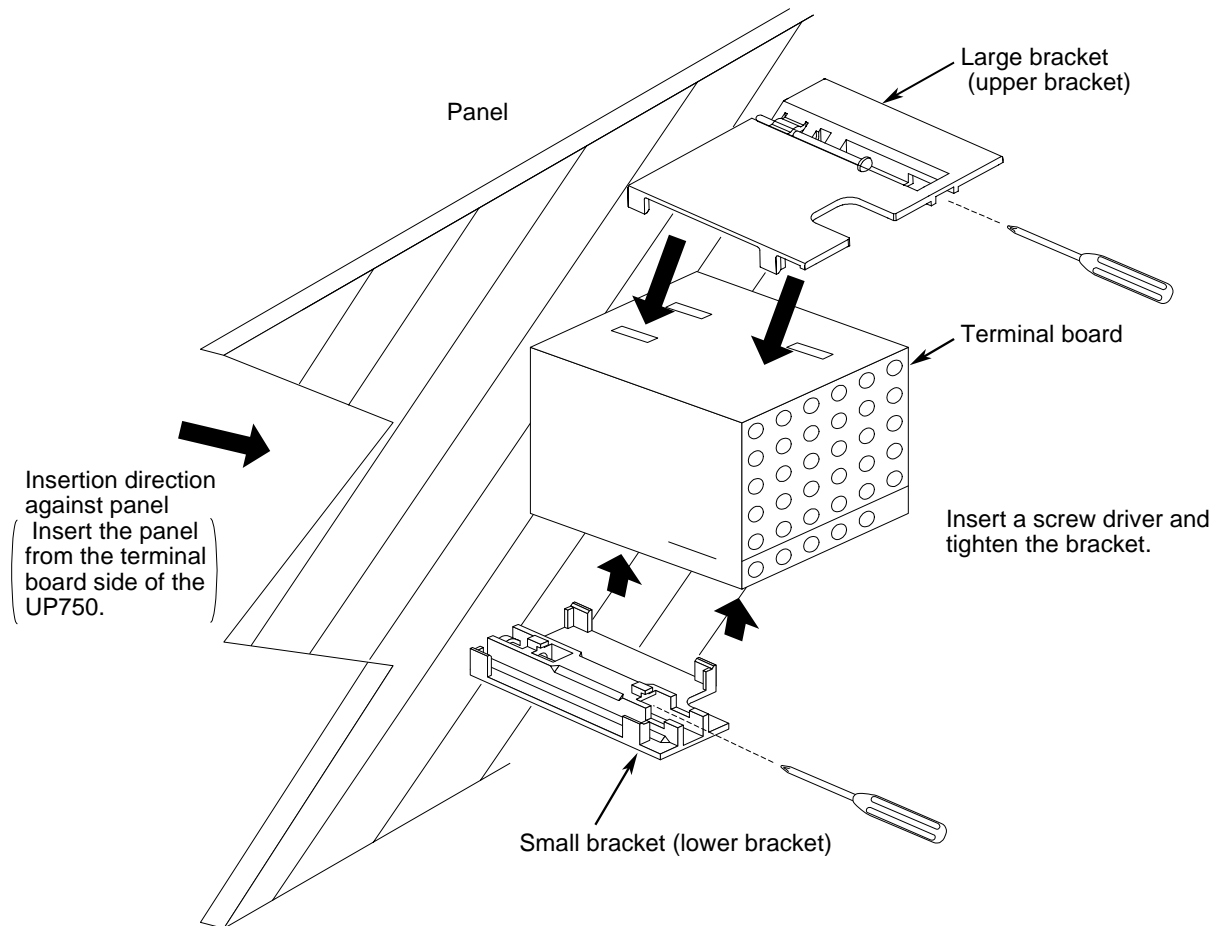

**Figure A2-4 Mounting**

- Step 1 : Cut the mounting panel, referring to the cutout dimensions shown in Section 2.2.
- Step 2 : Insert the controller in the cutout with the back panel of terminals first.
- Step 3 : Set the top and bottom brackets on the controller and clamp the controller to the panel.  
(UT550 uses a pair of a large top bracket and a small bottom bracket. UT520 uses a pair of brackets of the same size.)



### IMPORTANT

---

Do not excessively tighten the clamp screws, protecting the controller housing and brackets against being damaged.

---



### IMPORTANT

---

If the controller must be mounted with its front panel facing upward, keep the inclination of the top within 30 degrees from its horizontal position. Do not mount the controller with its front panel facing downward.

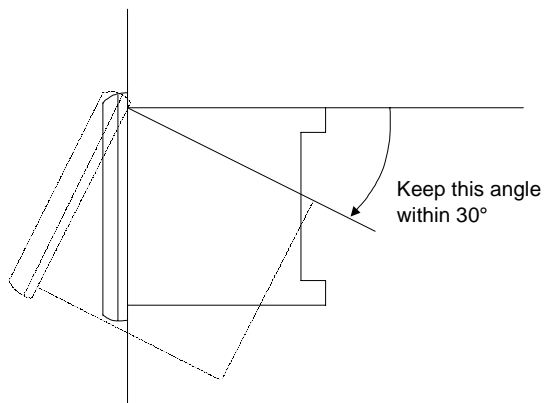

## E.4 Wiring

### UT520 Standard Terminal Assignment

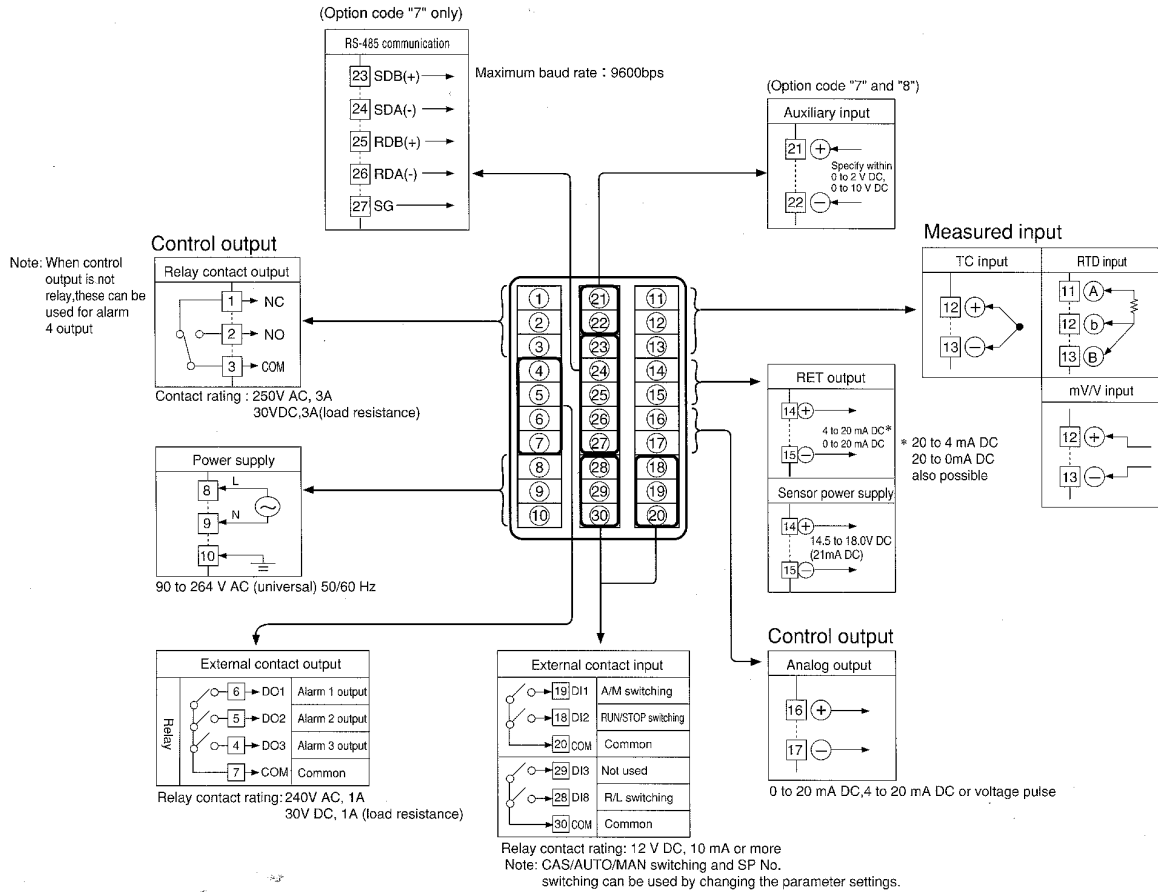

# UT550 Standard Terminal Assignment

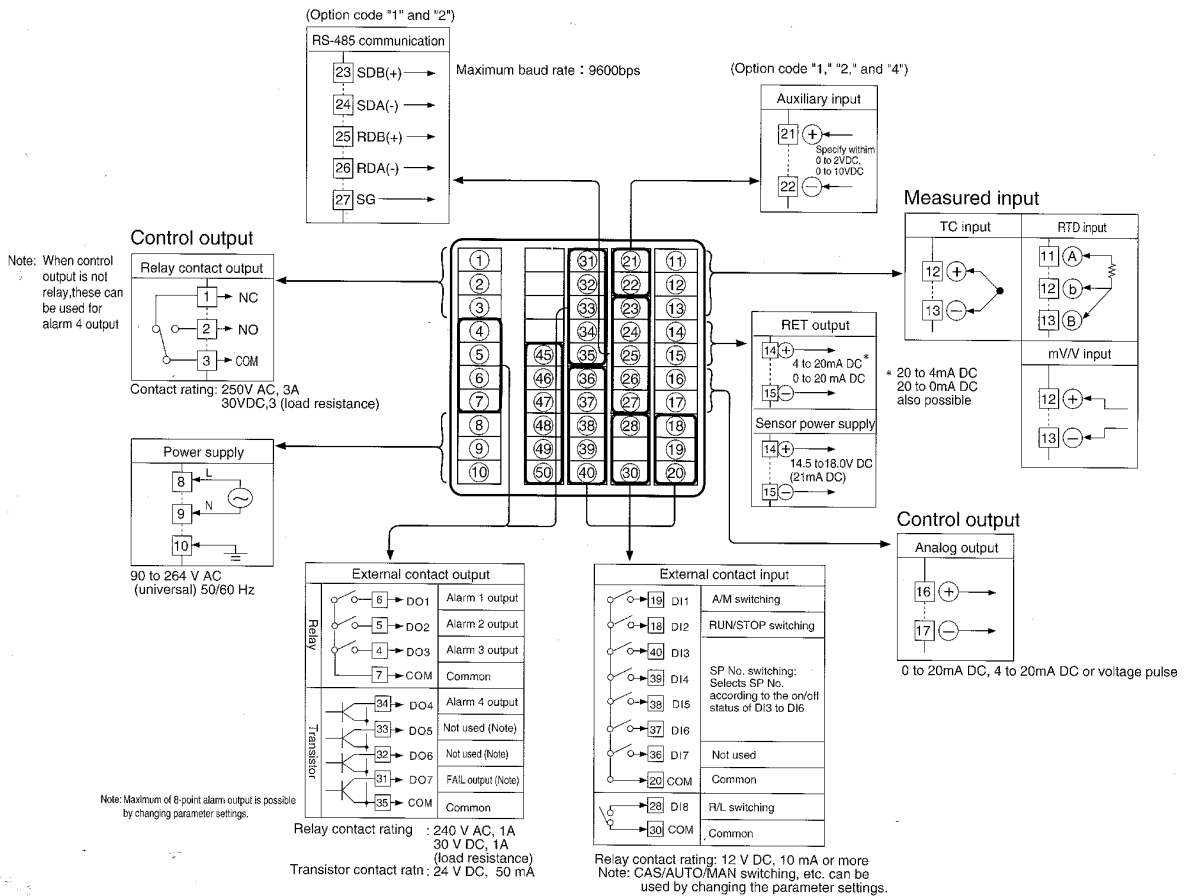

# UT750 Single/Dual Loop Terminal Assignment

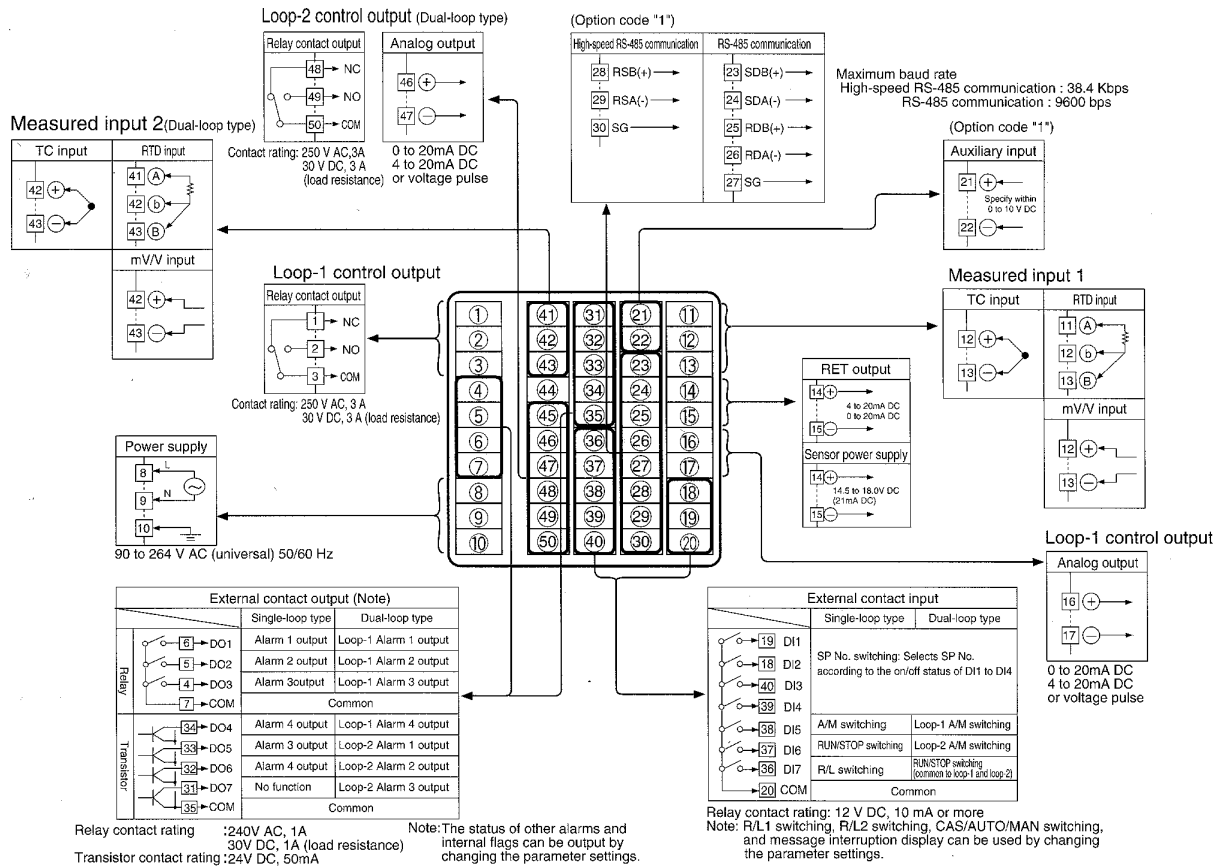

## E.5 Terminal Covers

An optional terminal cover is available, which can be used to keep the terminals from accidentally being touched and prevent electric shock.

To order the cover, specify T9115YD for the UT550 controller or T9115YE for the UT520 controller.

Part No.	Applicable controller	Unit
T9115YD	UT550	One sets of upper and lower bracket
T9115YE	UT520	One sets of upper and lower bracket

### ● Installing the terminal cover



#### CAUTION

Never touch the terminals in the rear panel to prevent electric shock when power is supplied to the controller during installation of the terminal cover.

First turn off the source circuit breaker, check to ensure that the power cable is not conducting electricity using a tester, and then install the cover in the manner described.

Step 1 : First fold the cover so that its grooved side is inside ('A' in the figure below). Never fold it on the wrong side, doing so not only disables installation but also reduces the cover's strength.

Step 2 : With the cover properly folded, fit its top and bottom holes on the hooks of the brackets ('B' in the figure).

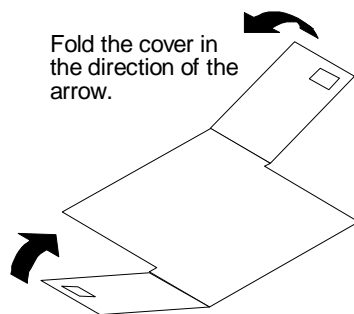

Figure A

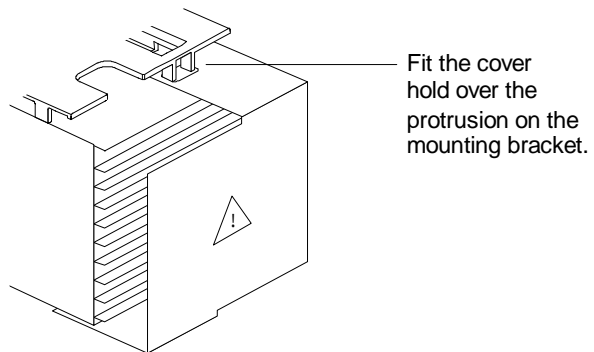

Figure B