

Uninterruptible Power Supply User Manual



SPS and SLN UPS Series

SOLAHD™

EMERSON™

CONTENTS

- 1.0 Introduction 1
- 2.0 Important Safety Instructions 2
- 3.0 General Description 3
- 4.0 System Block Diagrams 5
- 5.0 Installation and Operation 6
- 6.0 LED Diagnostics 7
- 7.0 Troubleshooting 8
- 8.0 Technical Specifications 9

What's Included

The UPS is shipped with the following items:

- User manual
- USB cable: high speed 2.0 Standard Type A-B, 6 ft (1.8 m)

Note: UPSwatch - monitoring/diagnostic software is available by downloading at www.solahd.com

The software is compatible with Windows 7, 8, 10, Windows 2008, 2012, 2016, Windows 2008/2012 Server Core, Hyper-V 2008/2012, Linux OpenSUSE 11.4, Linux ubuntu 10.04, Linux Fedora 3.1.9, CentOS 5.8, Citrix XenServer 6.0.0, Linux KVM

Accessories (Optional)

- SLNSPSPMBRK: SLN600 and SPS850 Wall Mount Bracket
- SLNSPSPMBRK1: SLN1000 and SLN1500 Wall Mount Bracket

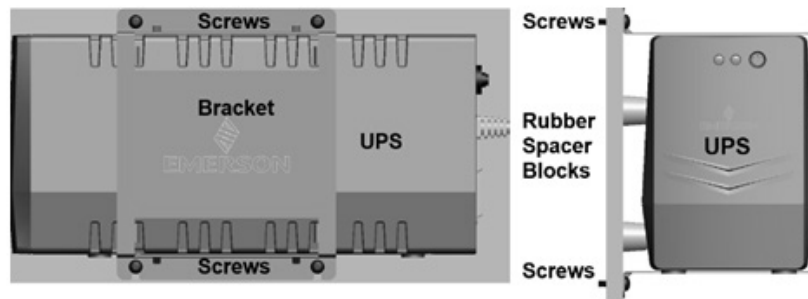

1.0 Introduction

Thank you for selecting the SPS or SLN Uninterruptible Power System. This manual contains important safety instructions that should be followed during the installation and operation of your UPS.

- Please read all safety, installation and operating instructions before attempting to install or operate the UPS.
- Please adhere to all warnings on the unit and in this manual during installation and operation.

This UPS is designed for industrial or commercial use. The UPS features a compact design that fits into a limited-space working environment.

This product features the following:

- High reliability.
- Auto restart during AC recovery.
- AC overload protection.
- Over temperature thermal protection.
- Battery overcharge protection.
- SLN models feature AVR (Auto Voltage Regulation).
- Input voltage out-of-range protection.
- Remote monitoring and control software via UPSwatch.

2.0 Important Safety Instructions

 **WARNING - Risk of electric shock, fire and personal injury.**

SAVE THESE INSTRUCTIONS - This manual contains important instructions that should be followed during installation and maintenance of the UPS.

The UPS is intended for installation in a controlled environment.

Do not attempt to open the UPS. The UPS contains no user-serviceable parts.

- Install the UPS in an indoor temperature- and humidity-controlled environment, free of conductive contaminants.
- Do not install the UPS in or near water.
- In order to avoid overheating the UPS, allow proper ventilation of the unit. Do not block or cover the top, bottom or sides of the UPS.
- Do not expose the UPS to direct sunlight or install the unit near any heat sources.
- Install the UPS onto a level surface in an upright position. Do not place the UPS on an unstable surface such as a cart, stand or table.
- The UPS must be installed near the socket receptacle so that the cord can be easily disconnected. To properly turn off the UPS, press the OFF button, then disconnect the input power supply cord from the AC power outlet.
- Connect the AC input power cord to a properly grounded AC supply source.
- Connect the UPS to a grounded supply circuit with proper branch circuit protection. Follow all applicable National Electrical Codes® (NEC®) and Canadian Electrical Codes (CEC) as well as all local codes.
- Do not plug the UPS into a power strip. Do not daisy-chain one UPS power cord into another UPS output receptacle. Do not place the UPS power cord where it may be damaged.
- Do not dispose of the UPS in a fire as the battery may explode.
- Do not open or damage the battery. Released electrolyte is harmful to the skin and eyes and may be toxic.
- The batteries are not user or service replaceable. Do not attempt to open the unit to replace them.
- Turn off the UPS and disconnect the input cord from the AC power supply before cleaning. Do not use liquid or aerosol cleaners. Use only a dry cloth on the exterior of the UPS. Do not open the unit.
- The UPS should not support laser printers or scanners, as the equipment may draw too much power, potentially resulting in a UPS overload.
- This UPS is not for use in a computer room as defined in the Standard For the Fire Protection of Information Technology Equipment, NFPA 75.

3.0 General Description

3.1 Front Panel - Models SLN600, SPS850, SLN1000, SLN1500

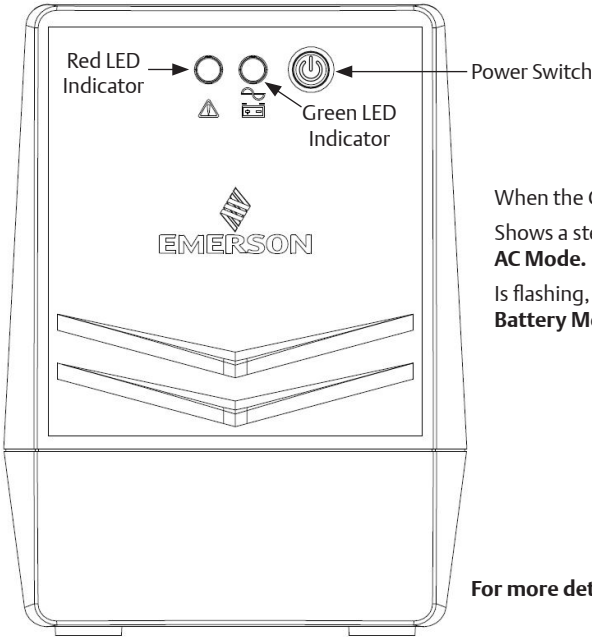

When the Green LED Indicator:
Shows a steady light, the UPS is in **AC Mode**.
Is flashing, the UPS is in **Battery Mode**.

For more details, refer to Section 6.0 LED Diagnostics.

3.2 Back Panel - Models SLN600, SPS850

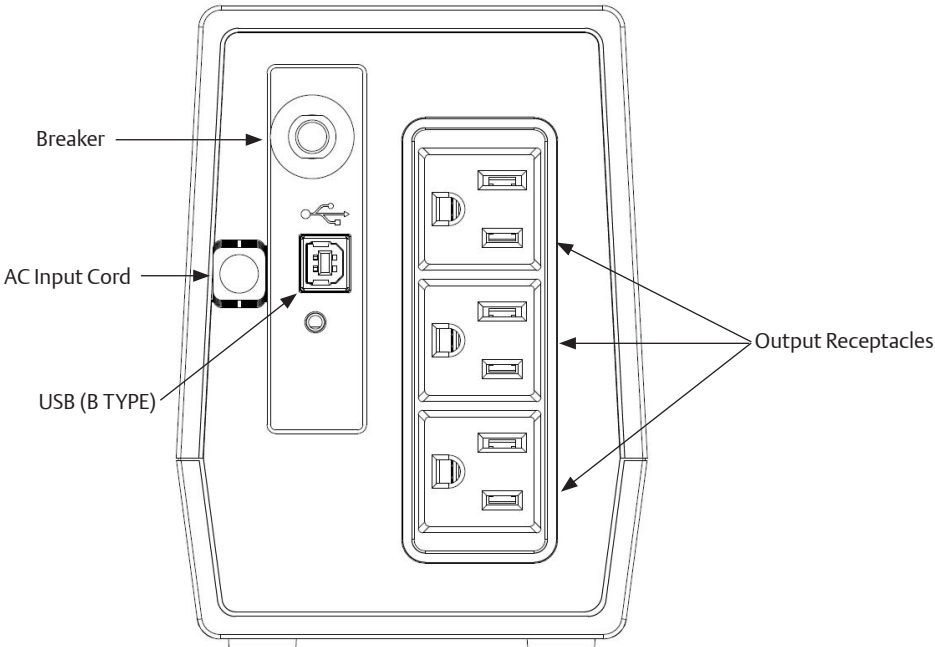

3.3 Back Panel - Model SLN1000

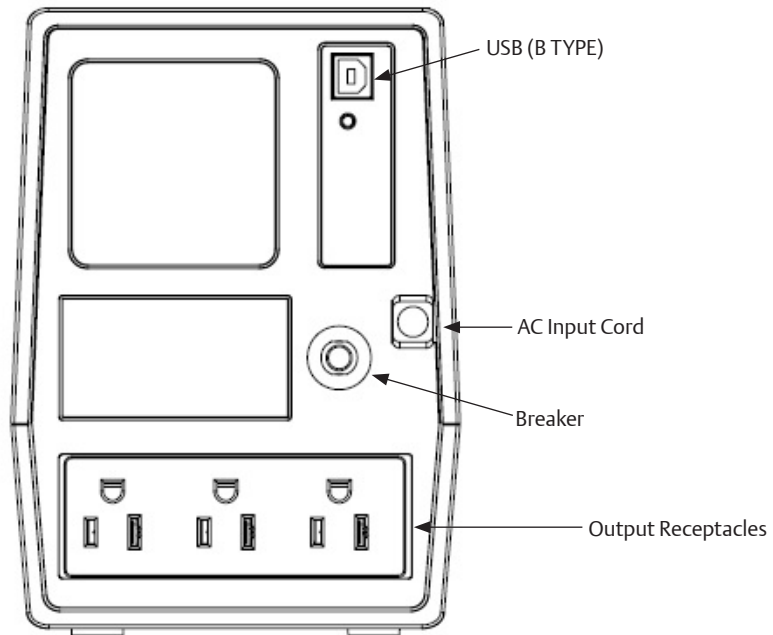

3.4 Back Panel - Model SLN1500

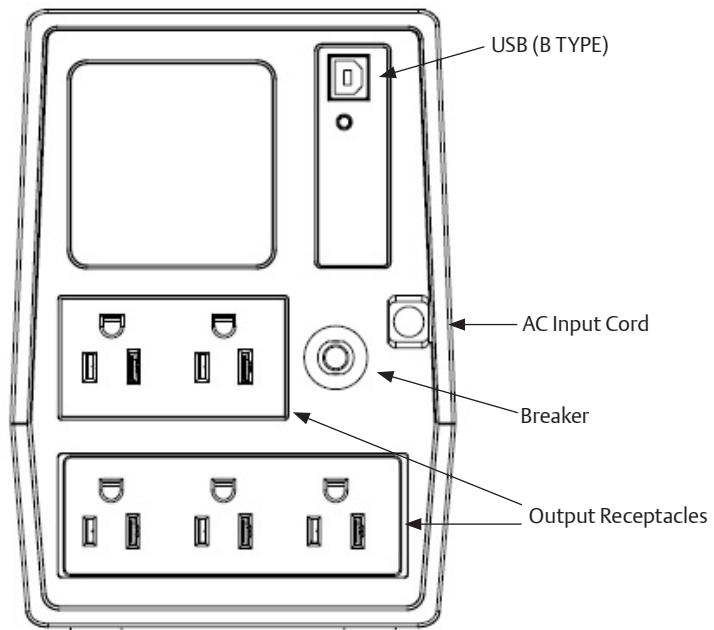

4.0 System Block Diagrams

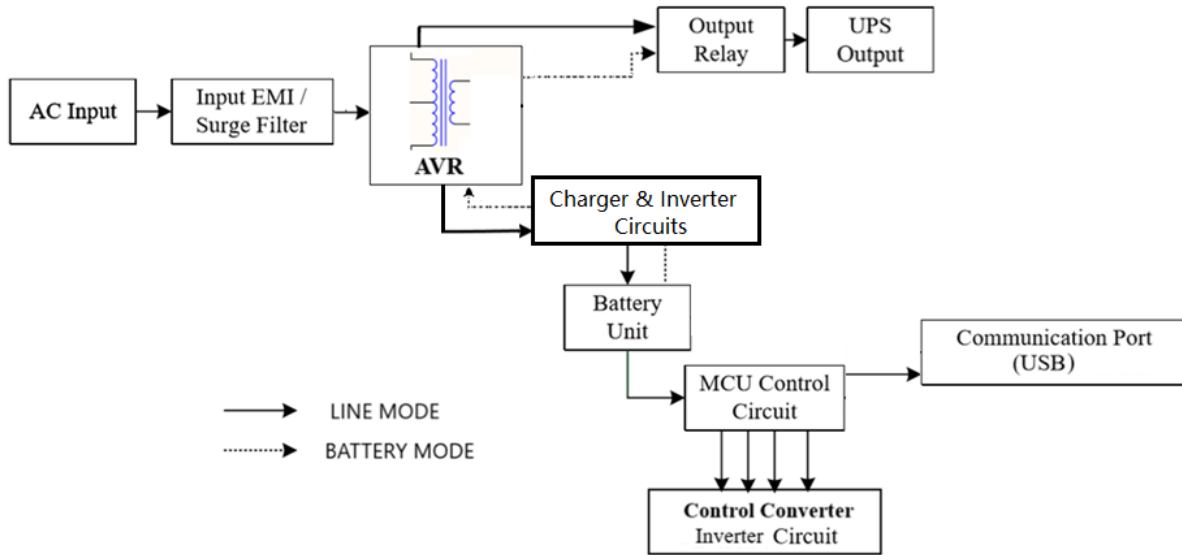

SLN System Block Diagram

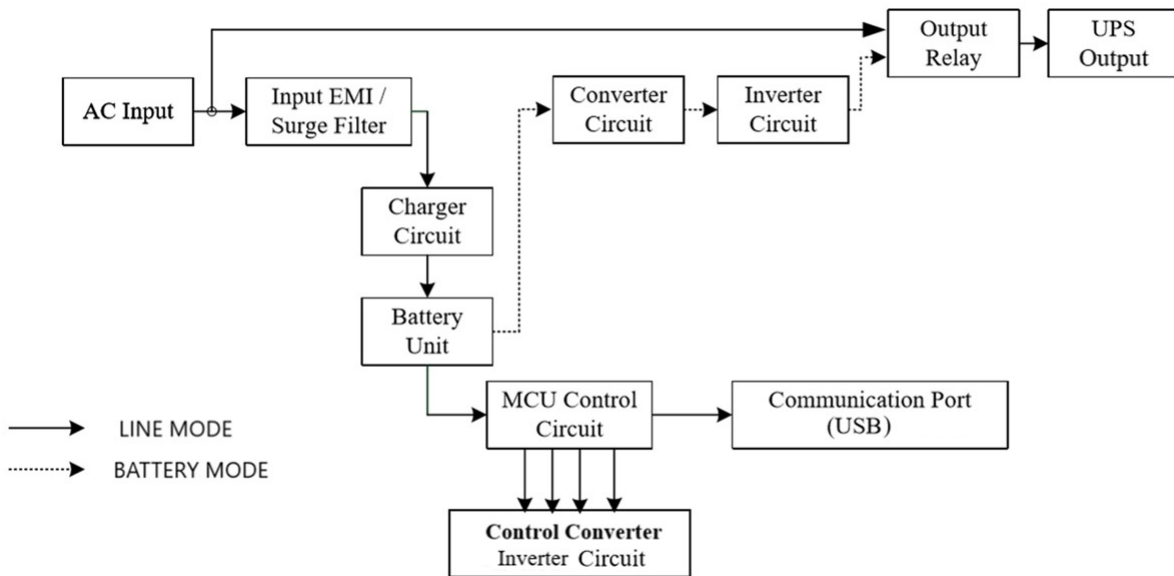

SPS System Block Diagram

5.0 Installation and Operation

5.1 Inspection

Remove the UPS from its packaging and inspect it for damage that may have occurred during shipping. If shipping damage has occurred, repack the unit, and contact your local carrier and SolaHD distributor immediately.

5.2 Placement

Install the UPS indoors in a protected environment that provides adequate airflow around the unit, and is free from excessive dust, moisture and contaminants. The UPS may be installed in an environment where the ambient temperature is 0°–40°C.

5.3 Starting the UPS

To turn on/off the UPS, press the power switch for 3 seconds.

When the Green LED Indicator:

- Shows a steady light, the UPS is in AC Mode.
- Is flashing, the UPS is in Battery Mode.

5.4 Battery Charging

Plug AC input cord into utility power for at least eight (8) hours in order to fully charge the battery prior to use, as some charge may have been lost during shipping. Unit does not need to be turned on in order for charging to occur.

5.5 Load/Output Connection

Connect one device into each of the power receptacles supplied on the back of the UPS.

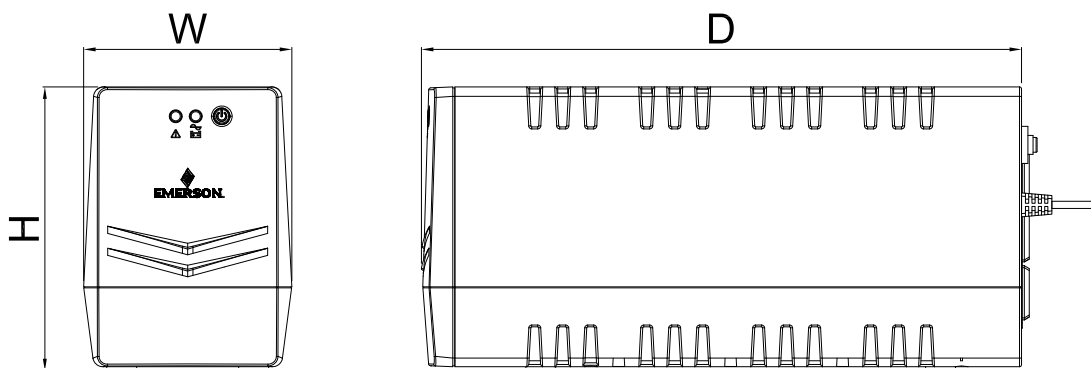

Catalog Number	Dimensions in Inches (Millimeters)		
	H	W	D
SLN600	5.6 (142)	4.1 (104)	11.8 (300)
SPS850	5.6 (142)	4.1 (104)	11.8 (300)
SLN1000	7.1 (180)	5.1 (130)	12.6 (320)
SLN1500	7.1 (180)	5.1 (130)	12.6 (320)

6.0 LED Diagnostics

Green LED	Red LED	Alarm (Audible)*	Status
ON	OFF	OFF	Battery Fully Charged
ON	OFF	OFF	AC Mode
Flashing every 5 seconds	OFF	1 beep every 5 seconds	Battery Mode
Flashing every 3 seconds	OFF	1 beep every 3 seconds	Battery Low Warning
Flashing every 1 second	OFF	OFF	Standby Mode
OFF	ON	Continuous beep every 1 minute for 1 hour	Fault Alarm
OFF	Flashing every 10 seconds	1 beep every 10 seconds	Over Temperature
Flashing every 10 seconds	OFF	OFF	Charging
OFF	Flashing every 3 seconds	Continuous beep every 3 seconds until fault is removed.	Output Short
Flashing every 3 seconds	OFF	OFF	Automatic Voltage Regulation (AVR) Mode - SLN Model Only

*NOTE: Push and release ON/OFF to silence or activate audible alarm.

7.0 Troubleshooting

Problem	Possible Cause	Solutions
The UPS does not turn on. (No alarm, no display).	The UPS is not turned on.	Press the ON/OFF Button for 3 seconds and release.
	Battery fault.	Contact Tech Support.
	UPS fault.	Contact Tech Support.
The UPS runs continually in battery mode.	The power cord is not connected properly.	Check the power cord to ensure it is connected properly.
Battery runtime cannot be achieved.	Battery voltage is too low.	Charge the battery (batteries) for at least eight (8) hours.
	Output overload.	Remove some loads. Before reconnecting equipment, please verify that the load matches the UPS capability shown in the specifications.
	Battery fault.	The UPS has been operating at high temperatures that are not conducive to the battery. If the battery is near the end of its life, please contact Customer Support.
	Charger fault or other reasons.	Contact Tech Support.
The red LED is on and beeps.	The UPS has overloaded.	Please disconnect loads or check if the load is shorted or malfunctioning.
Green LED flashes every 1 second with no sound and no output voltage.	Battery voltage is too low.	Please check if the AC is normal or the power cord is disconnected. When the utility is normal, the UPS will automatically restart and charge the battery.
The green and red LEDs are always on and the audible alarm is silent.	Charge circuit error.	Contact Tech Support.
The red LED flashes, and the audible alarm is silent.	The UPS is overheated.	Check that the UPS has good ventilation and is not in direct sunlight or near heat sources. Reduce the output load.

8.0 Technical Specifications

		Line Interactive	Offline	Line Interactive	Line Interactive
Catalog Number		SLN 600	SPS850	SLN 1000	SLN 1500
VA/Watts		600VA/360W	850/510	1000VA/600W	1500VA/900W
Runtime	10%	87 min.	67 min.	2 hours	1 hour 3 min.
	20%	45 min.	31 min. 10 sec.	48 min.	41 min. 30 sec.
	30%	27 min.	18 min. 40 sec.	27 min.	20 min.
	40%	19 min. 30 sec.	12 min. 22 sec.	19 min. 18 sec.	13 min. 26 sec.
	50%	13 min. 30 sec.	9 min. 6 sec.	13 min.	10 min. 9 sec.
	60%	10 min. 30 sec.	6 min. 40 sec.	10 min. 30 sec.	8 min. 11 sec.
	70%	8 min. 10 sec.	5 min. 6 sec.	8 min.	6 min. 22 sec.
	80%	6 min. 30 sec.	4 min. 7 sec.	5 min. 50 sec.	5 min. 13 sec.
	90%	4 min. 40 sec.	3 min. 5 sec.	4 min.	4 min. 6 sec.
	100%	3 min. 28 sec.	2 min. 20 sec.	3 min.	2 min. 55 sec.

NOTE: Run times in this table are approximate. They are based upon new, fully charged standard battery modules at a temperature of 25°C (77°F) with 100% resistive UPS loading. Run times listed above can vary due to manufacturing variances of the individual batteries.

Catalog Number	SLN600	SPS850	SLN1000	SLN1500
Topology	Line Interactive	Offline	Line Interactive	Line Interactive
Capacity (VA/W)	600/360	850/510	1000/600	1500/900
Dimensions				
Unit (H x W x D) - in. (mm)	5.6x4.1x11.82 (142x104x300.2)	5.6x4.1x11.82 (142x104x300.2)	7.09x5.12x12.6 (180x130x320)	7.09x5.12x12.6 (180x130x320)
Ship Weight - lbs (kg)	12.13 (5.5) ± 10%	8.16 (3.7) ± 10%	19.62 (8.9) ± 10%	25.35 (11.5) ± 10%
Input Parameters				
Voltage	120 Vac -23% / +29%	120 Vac -25% / +20%	120 Vac -23% / +29%	
Frequency	50/60 Hz +/- 10% (auto sensing)			
Input Power Cord	5 ft. with NEMA 5-15P			
Output AC Parameters				
Voltage (Battery Mode)	120V±10%			
Frequency (On Battery)	50/60 Hz			
Auto Voltage Regulation (AVR function under Normal Mode)	V _{out} = Input 102 Vac x 118% at Boost mode V _{out} = Input 138 Vac x 85% at Buck mode	N/A	V _{out} = Input 102 Vac x 118% at Boost mode V _{out} = Input 138 Vac x 85% at Buck mode	
Overload Protection	Line Mode: 1. 110%±5% load for 5 mins. After, the power will not be provided to the load. Then, every 10 mins, auto recovery will be attempted. 2. 120%±5% load for 10 seconds. After, the power will not be provided to the load. Then, every 10 mins, auto recovery will be attempted. 3. 130%±5% load for 1.5 seconds. After, the power will not be provided to the load. Then, every 10 mins, auto recovery will be attempted.	Breaker Protection	Line Mode: 1. 110%±5% load for 5 mins. After, the power will not be provided to the load. Then, every 10 mins, auto recovery will be attempted. 2. 120%±5% load for 10 seconds. After, the power will not be provided to the load. Then, every 10 mins, auto recovery will be attempted. 3. 130%±5% load for 1.5 seconds. After, the power will not be provided to the load. Then, every 10 mins, auto recovery will be attempted.	

Catalog Number	SLN600	SPS850	SLN1000	SLN1500
Short Circuit * OSCP is Output Short Circuit Protection	<ol style="list-style-type: none"> The Output current continues over 125% within 60ms to OSCP* and then goes to Battery MODE. UPS goes to retry mode every 10 seconds until the Battery Voltage (V_b) < 11V/cell. The Battery recharges when the $V_b > 12.7V$/cell, then UPS continues retry mode every 10 seconds. UPS goes to auto recovery mode until the short circuit disappears then goes back to LINE Mode. 	<ol style="list-style-type: none"> The Output current continues over 250% within 60ms to OSCP* and then goes to Battery MODE. UPS goes to retry mode every 10 seconds until the Battery Voltage (V_b) < 11V/cell. The Battery recharges when the $V_b > 12.7V$/cell, then UPS continues retry mode every 10 seconds. UPS goes to auto recovery mode until the short circuit disappears then goes back to LINE Mode. 	<ol style="list-style-type: none"> The Output current continues over 125% within 60ms to OSCP* and then goes to Battery MODE. UPS goes to retry mode every 10 seconds until the Battery Voltage (V_b) < 11V/cell. The Battery recharges when the $V_b > 12.7V$/cell, then UPS continues retry mode every 10 seconds. UPS goes to auto recovery mode until the short circuit disappears then goes back to LINE Mode. 	
Battery Parameters				
Battery Type	VRLA, maintenance free, sealed, lead-acid cells			
Transfer Time	Typical: 8ms, max. <10ms@AC mode to backup mode			
Typical Recharge Time	8 hours			
Environmental				
Operating Temperature	0 to +40°C			
Storage Temperature	-15 to +45°C			
Relative Humidity	0% to 90% relative humidity, non-condensing			
Audible Noise	≤40 dBA without audible alarm beyond 1m at rated load			
Standards				
EMC	FCC Part 15, Subpart B, Class A; EN62040-2; EN55032; CISPR22			
Surge Protection	Meets IEEE C62.41, Category A & B Delta: (Line to line: 1kV; line to earth: 2kV)	Meets IEEE C62.41, Category A	Meets IEEE C62.41, Category A & B L-L: 1kV; IL-E: 2kV	
Certifications	cULus Listed, UPS Equipment UL 1778, CSA C22.2 No. 107.3			

The information in this manual is provided as a guide for installation, operation, and maintenance. It does not affect or exceed our obligations under the Terms and Conditions of Sale.

Note that unit specifications are subject to change without notice.

Technical Support

Website: www.solahd.com

Technical Support E-Mail: solahd.technicalservices@emerson.com

Toll-Free: (800) 377-4384

USA: (847) 268-6651

Warranty

Please see the “Terms & Conditions of Sale” document within the UPS packaging.

While every precaution has been taken to ensure accuracy and completeness in this manual, Appleton Grp LLC d/b/a Appleton Group assumes no responsibility, and disclaims all liability for damages resulting from use of this information or for any errors or omissions.

SPS and SLN UPS Series

A272-319 Rev. 0 09/2019

The Emerson logo is a trademark and service mark of Emerson Electric Co.
Appleton Grp LLC d/b/a Appleton Group. SolaHD is a registered trademark of Appleton Grp LLC.
All other marks are the property of their respective owners. © 2019 Emerson Electric Co. All rights reserved.

United States (Headquarters)

Appleton Grp LLC
9377 W. Higgins Road
Rosemont, IL 60018
United States
T +1 800 621 1506

Australia Sales Office

Bayswater, Victoria
T +61 3 9721 0348

Korea Sales Office

Seoul
T +82 2 3483 1555

Europe

ATX SAS
Espace Industriel Nord
35, rue André Durouchez,
CS 98017
80084 Amiens Cedex 2
France
T +33 3 2254 1390

China Sales Office

Shanghai
T +86 21 3338 7000

Canada

EGS Electrical Group Canada
Ltd.
99 Union Street
Elmira ON, N3B 3L7
Canada
T +1 888 765 2226

Middle East Sales Office

Dammam, Saudi Arabia
T +966 13 510 3702

Asia Pacific

EGS Private Ltd.
Block 4008, Ang Mo Kio
Ave 10,
#04-16 TechPlace 1,
Singapore 569625
T +65 6556 1100

Chile Sales Office

Las Condes
T +56 2928 4819

Latin America

EGS Comercializadora
Mexico S de RL de CV
Calle 10 N°145 Piso 3
Col. San Pedro de los Pinos
Del. Álvaro Obregon
Ciudad de México. 01180
T +52 55 5809 5049

India Sales Office

Chennai
T +91 44 3919 7300

SOLAHD™

