

# Technical Information

## Thermowell

### Omnigrad M TW13

Pipe thermowell  
Flanged process connection



#### Application

TW13 is designed for use in the fine chemicals industry but can also be used for generic applications.

Modular configuration according to DIN 43772 (form 2F/3F) enable a use in all industrial processes with severe thermal and mechanical stresses.

#### Your benefits

- TW13 is a pipe thermowell.
- The process connection is flanged.
- Extension, immersion length and total length can be chosen according to process requirements.
- A wide choice of dimensions, materials and process connections is available.
- Special versions can be manufactured according to customer requirements.

## Function and system design

### Equipment architecture

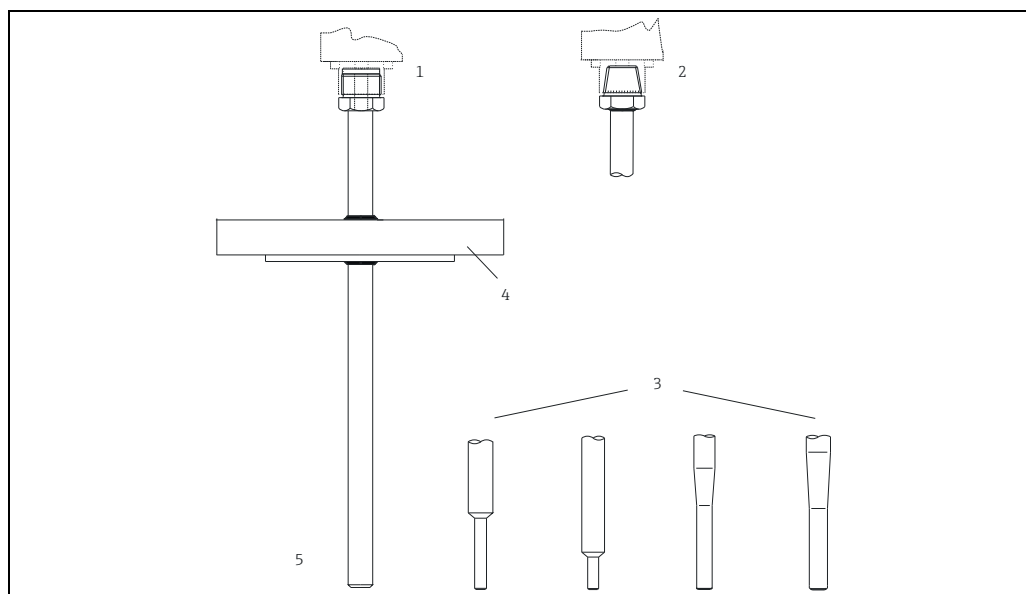

Equipment architecture of the Omnigrad M TW13

- 1 Thread M24x1.5
- 2 Thread 1/2" NPT
- 3 Various tip shapes - detailed information see chapter "Tip shape"
- 4 Process connection: flange
- 5 Jacket (protective sheath)

The Omnigrad M TW13 thermowells are designed according to DIN 43772 and can therefore guarantee a good level of resistance to the most typical and common industrial processes. The thermowell is made from a pipe with a diameter of 9, 11, 12, 14 or 15 mm (0.35, 0.43, 0.47, 0.55 or 0.59 in). The end of the thermowell can be straight, tapered or reduced (stepped). An oversheath in plastic can be supplied for thermowells with straight tip. The Omnigrad M TW13 thermowells can be fitted on the plant (pipe or vessel) using a flanged process connection, which can be chosen from the most common models.

## Performance characteristics

### Operating conditions

### Process pressure

The pressure values to which the thermowell can be subjected at the various temperatures and maximum permitted flow velocity are illustrated by the figure below. Occasionally, the pressure loading capacity of the process connection can be considerably lower. The maximum allowable process pressure for a specific thermometer is derived from the lower pressure value of the thermowell and process connection.

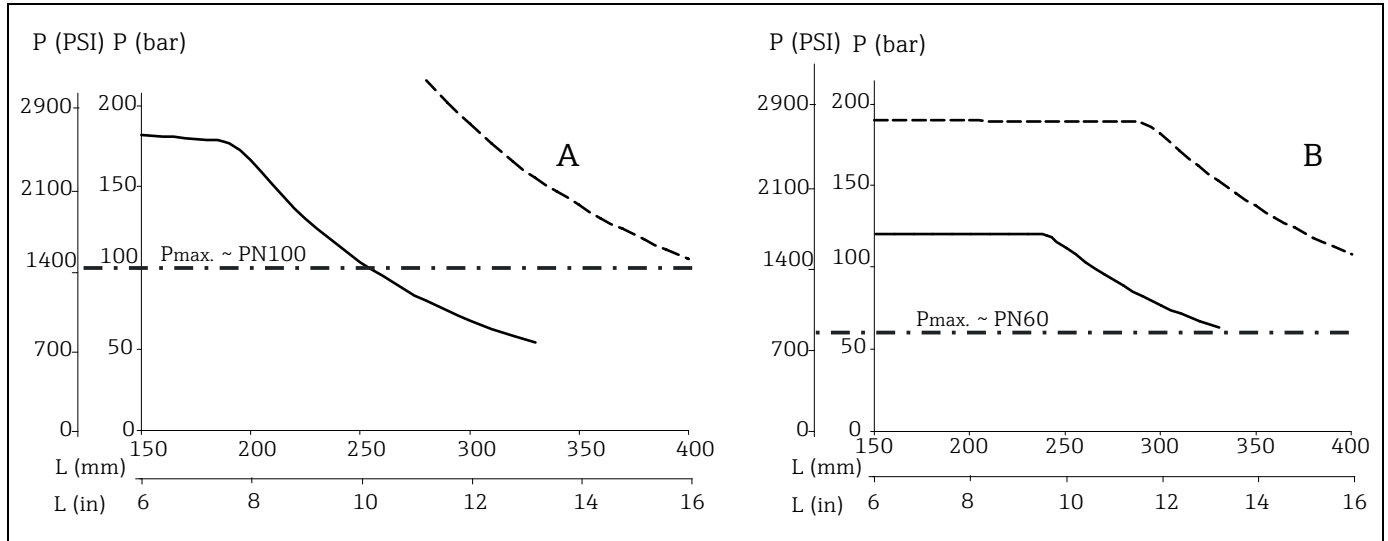

Maximum permitted process pressure for tube diameter

- A Medium water at  $T = 50\text{ °C}$  ( $122\text{ °F}$ )
- B Medium superheated steam at  $T = 400\text{ °C}$  ( $752\text{ °F}$ )
- L Immersion length
- P Process pressure
- Thermowell diameter  $9 \times 1\text{ mm}$  ( $0.35\text{ in}$ )
- - - Thermowell diameter  $12 \times 12.5\text{ mm}$  ( $0.47\text{ in}$ )



Note the limitation of the maximum process pressure to the flange pressure ratings indicated in the following table.

Process connection	Standard	Max. process pressure
Flange	EN1092-1 or ISO 7005-1	Depending on the flange pressure rating PNxx: 20, 40, 50 or 100 bar at $20\text{ °C}$ ( $68\text{ °F}$ )
	ANSI B16.5	Depending on the flange pressure rating 150 or 300 psi at $20\text{ °C}$ ( $68\text{ °F}$ )
	JIS B 2220	Depending on the flange pressure rating 20K, 25K or 40K
	DIN2526/7	Depending on the flange pressure rating PN40 at $20\text{ °C}$ ( $68\text{ °F}$ )

**Maximum flow velocity**

The highest flow velocity tolerated by the thermowell diminishes with increasing immersion length exposed to the stream of the fluid. Detailed information may be taken from the figure below.

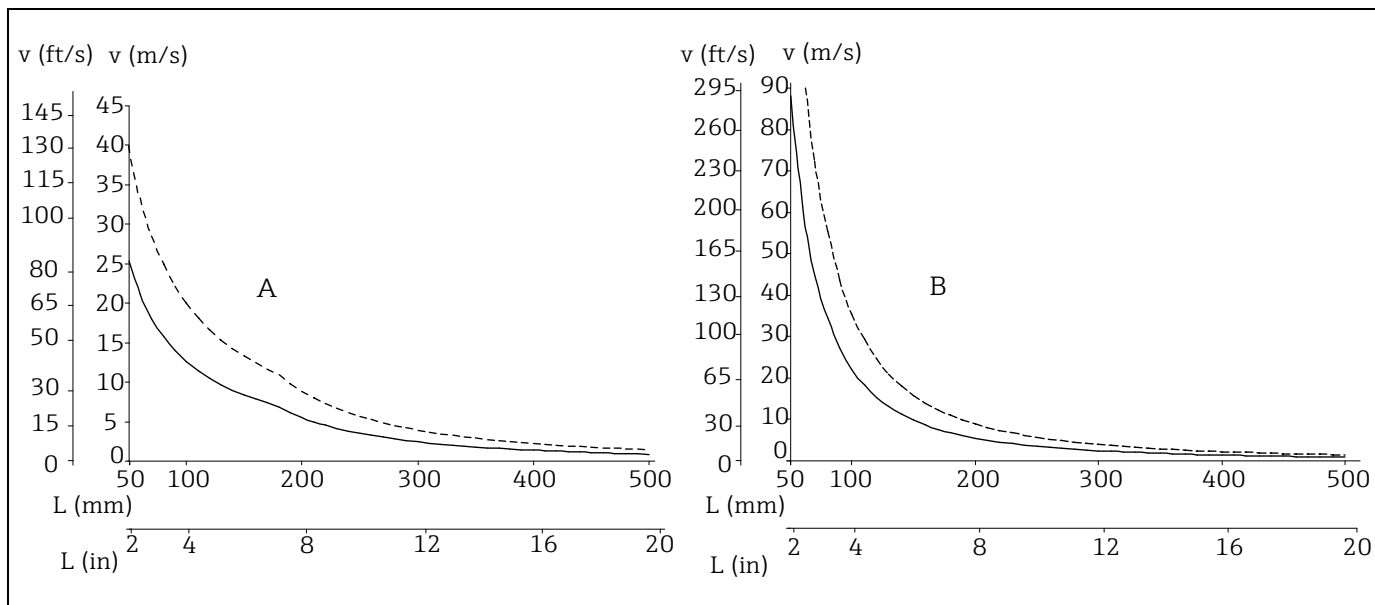

Flow velocity depending on the immersion length

- A Medium water at T = 50 °C (122 °F)
- B Medium superheated steam at T = 400 °C (752 °F)
- L Immersion length
- v Flow velocity
- Thermowell diameter 9 x 1 mm (0.35 in)
- - - Thermowell diameter 12 x 12.5 mm (0.47 in)

**Material**

Thermowell and process connections.

The temperatures for continuous operation specified in the following table are only intended as reference values for use of the various materials in air and without any significant compressive load. The maximum operation temperatures are reduced considerably in some cases where abnormal conditions such as high mechanical load occur or in aggressive media.

Material name	Short form	Recommended max. temperature for continuous use in air	Properties
AISI 316L/1.4404 1.4435	X2CrNiMo17-12-2 X2CrNiMo18-14-3	650 °C (1202 °F) <sup>1)</sup>	<ul style="list-style-type: none"> <li>▪ Austenitic, stainless steel</li> <li>▪ High corrosion resistance in general</li> <li>▪ Particularly high corrosion resistance in chlorine-based and acidic, non-oxidizing atmospheres through the addition of molybdenum (e.g. phosphoric and sulfuric acids, acetic and tartaric acids with a low concentration)</li> <li>▪ Increased resistance to intergranular corrosion and pitting</li> <li>▪ Compared to 1.4404, 1.4435 has even higher corrosion resistance and a lower delta ferrite content</li> </ul>
AISI 316Ti/1.4571	X6CrNiMoTi17-12-2	700 °C (1292 °F) <sup>1)</sup>	<ul style="list-style-type: none"> <li>▪ Properties comparable to AISI316L</li> <li>▪ Addition of titanium means increased resistance to intergranular corrosion even after welding</li> <li>▪ Broad range of uses in the chemical, petrochemical and oil industries as well as in coal chemistry</li> <li>▪ Can only be polished to a limited extent, titanium streaks can form</li> </ul>
Hastelloy® C276/ 2.4819	NiMo16Cr15 W	1100 °C (2012 °F)	<ul style="list-style-type: none"> <li>▪ A nickel-based alloy with good resistance to oxidizing and reducing atmospheres, even at high temperatures</li> <li>▪ Particularly resistant to chlorine gas and chloride as well as to many oxidizing mineral and organic acids</li> </ul>
Inconel600/2.4816	NiCr15Fe	1100 °C (2012 °F)	<ul style="list-style-type: none"> <li>▪ A nickel/chromium alloy with very good resistance to aggressive, oxidizing and reducing atmospheres, even at high temperatures</li> <li>▪ Resistant to corrosion caused by chlorine gas and chlorinated media as well as many oxidizing mineral and organic acids, sea water etc.</li> <li>▪ Corrosion from ultrapure water</li> <li>▪ Not to be used in a sulfur-containing atmosphere</li> </ul>
PTFE (Teflon)	Polytetrafluorethylen	100 °C (212 °F)	<ul style="list-style-type: none"> <li>▪ Resistant to almost all chemicals</li> <li>▪ High temperature stability</li> <li>▪ Max. operating pressure: &lt;2 bar (29 psi)</li> </ul>
PVDF	Polyvinylidene fluoride	80 °C (176 °F)	<ul style="list-style-type: none"> <li>▪ High stability</li> <li>▪ A high creepage stability under continuous demand</li> <li>▪ Good cold properties</li> </ul>
Tantalum	-	250 °C (482 °F)	<ul style="list-style-type: none"> <li>▪ With the exception of hydrofluoric acid, fluorine and fluorides, tantalum exhibits excellent resistance to most mineral acids and saline solutions</li> <li>▪ Prone to oxidation and embrittlement at higher temperatures in air</li> </ul>

- 1) Can be used to a limited extent up to 800 °C (1472 °F) for low compressive loads and in non-corrosive media. Please contact your Endress+Hauser sales team for further information.

## Components

### Design, dimensions

All dimensions in mm (in).

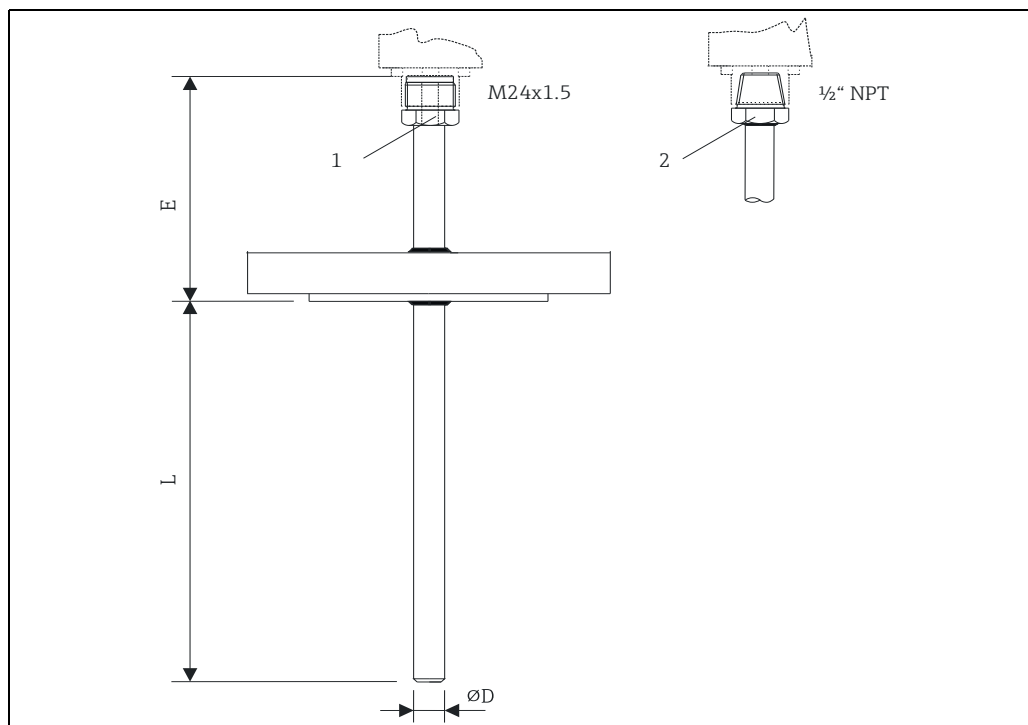

Dimensions of the Omnigrad M TW13

A0020855

1	M24x1.5 connection; sliding on the neck	L	Immersion length
2	1/2" NPT connection; welded, not sliding on the neck	ØD	Diameter
E	Neck tube length		



The standard lengths of the neck are 80 or 145 mm (3.15 or 5.71 in). In accordance with standard DIN 43772, in the case of a thermowell with a diameter of  $\varnothing 12$  mm (0.47 in) and a tapered tip (form 3F), the extension neck will respectively be 82 or 147 mm (3.23 or 5.79 in).

**Tip shape**

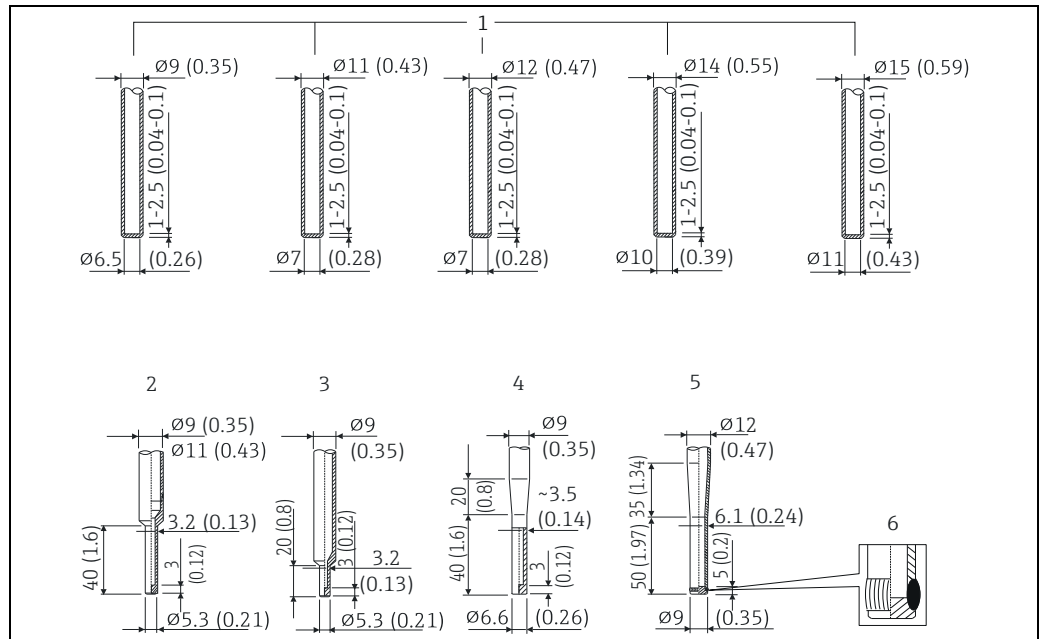

Available thermowell tips (reduced, straight or tapered). Maximum surface roughness  $R_a \leq 1.6 \mu\text{m}$  (62.9  $\mu\text{in}$ )

Pos. No.	Tip shape	Insert diameter
1	Straight	6 mm (0.24 in)
2	Reduced, $L \geq 50 \text{ mm}$ (1,97 in)	3 mm (0.12 in)
3	Reduced, $L \geq 30 \text{ mm}$ (1,18 in) <sup>1)</sup>	3 mm (0.12 in)
4	Tapered, $L \geq 70 \text{ mm}$ (2,76 in) <sup>1)</sup>	3 mm (0.12 in)
5	Tapered DIN 43772-3F, $L \geq 90 \text{ m}$ (3,54 in) <sup>1)</sup>	6 mm (0.24 in)
6	Welded tip, weld quality according to EN ISO 5817 - quality class B	

1) not with material Hastelloy® C276/2.4819 and Inconel600

**Weight**

From 1.5 to 4.0 kg (3.3 to 8.8 lbs) for standard options.

**Process connection**

Standard connections are available as weld-in connection (without flange) or with flange. The following figure shows the basic dimensions of the available flanges.

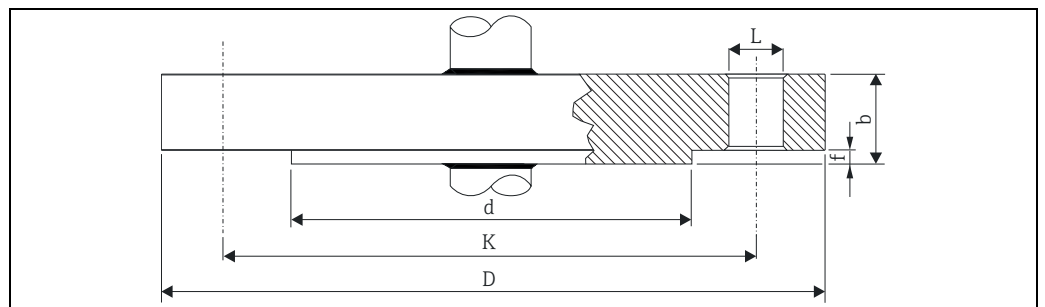

Basic dimensions of the flange process connections

For detailed information on the flange dimensions refer to the following flange standards:

- ANSI/ASME B16.5
- ISO 7005-1

- EN 1092-1
- JIS B 2220 : 2004
- DIN 2526/7

The flange material should be the same as of the stem of the thermowell. For this reason, connections are available both in SS 316L/1.4404 and in SS 316Ti/1.4571. Models in Hastelloy® C have flanges in basic material SS 316L and a disc in Hastelloy® C on the surface in contact with the process media.

## Installation conditions

### Orientation

No restrictions.

### Installation instructions

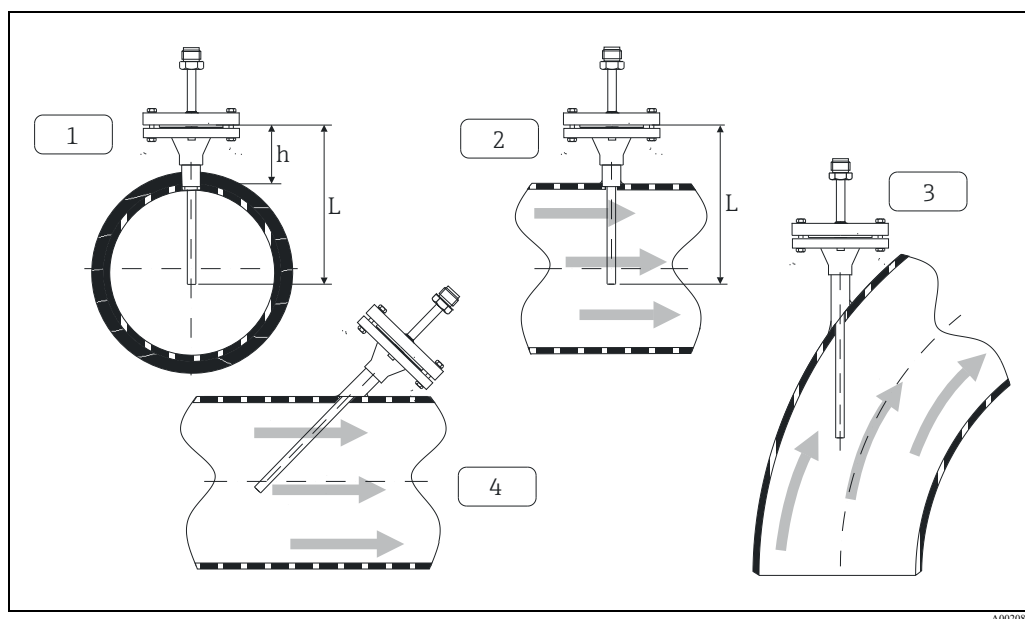

#### Installation examples

- 1 - 2: In pipes with a small cross section the sensor tip should reach or extend slightly past the center line of the pipe (= L)  
 3 - 4: Tilted installation

The immersion length of the thermometer influences the accuracy. If the immersion length is too small then errors in the measurement are caused by heat conduction via the process connection and the container wall. If installing into a pipe then the immersion length should be half of the pipe diameter, if possible (see 1 and 2). A further solution could be an angled (tilted) installation (see 3 and 4). When determining the immersion length all thermometer parameters and the process to be measured must be taken into account (e.g. flow velocity, process pressure).

- Installation possibilities: Pipes, tanks or other plant components
- Recommended minimum immersion length = 80 to 100 mm (3.15 to 3.94 in)  
 The immersion length should correspond to at least 8 times of the thermowell diameter.  
 Example: Thermowell diameter 12 mm (0.47 in) x 8 = 96 mm (3.8 in). A standard immersion length of 120 mm (4.72 in) is recommended.
- ATEX certification: Always take note of the installation regulations!



## Certificates and approvals

---

<b>CE mark</b>	The device meets the legal requirements of the EC directives if applicable. Endress+Hauser confirms that the device has been successfully tested by applying the CE mark.
<b>PED approval</b>	The thermowell complies with paragraph 3.3 of the Pressure Equipment Directive (97/23/CE) and is not marked separately.
<b>Material certification</b>	The material certificate 3.1 (according to standard EN 10204) can be directly selected from the sales structure of the product and refers to the parts of the sensor in contact with the process fluid. Other types of certificates related to materials can be requested separately. The "short form" certificate includes a simplified declaration with no enclosures of documents related to the materials used in the construction of the single sensor and guarantees the traceability of the materials through the identification number of the thermometer. The data related to the origin of the materials can subsequently be requested by the client if necessary.
<b>Test on thermowell</b>	Thermowell pressure tests are carried out in accordance with the specifications in the DIN 43772 standard. With regards to thermowells with tapered or reduced tips that do not comply with this standard these are tested using the pressure of corresponding straight thermowells. Sensors certified for use in Ex Zones, are always tested to pressures according to the same criteria. Tests according to other specifications can be carried out on request. Dye penetration tests verify the absence of cracks on the thermowell welding.

## Ordering information

Detailed ordering information is available from the following sources:

- In the Product Configurator on the Endress+Hauser website:  
www.endress.com → Select country → Instruments → Select device → Product page function: Configure this product
- From your Endress+Hauser Sales Center:  
www.endress.com/worldwide



### **Product Configurator - the tool for individual product configuration:**

- Up-to-the-minute configuration data
- Depending on the device: Direct input of measuring point-specific information such as measuring range or operating language
- Automatic verification of exclusion criteria
- Automatic creation of the order code and its breakdown in PDF or Excel output format
- Ability to order directly in the Endress+Hauser Online Shop

[www.addresses.endress.com](http://www.addresses.endress.com)

---