



Time Electronics
Calibration, Test and Measurement

User Manual

5070

Ductor Tester / Micro-Ohmmeter Calibrator

Version 1.1
May 2021

Time Electronics Ltd

Unit 5, TON Business Park, 2-8 Morley Road,
Tonbridge, Kent, TN9 1RA, United Kingdom.

T: +44 (0) 1732 355993 | F: +44 (0) 1732 350198
mail@timeelectronics.co.uk | www.timeelectronics.com

© 2021 Time Electronics Ltd.

All rights reserved.

Nothing from this manual may be multiplied, or made public in any form or manner, either electronically or hard copy, without prior written consent from Time Electronics Ltd.

This also applies to any schematics, drawings and diagrams contained herein.

This manual provides operating and safety instructions for the Time Electronics product.

To ensure correct operation and safety, please follow the instructions in this manual.

Time Electronics reserves the right to change the contents, specifications and other information contained in this manual without notice.

Contents

1	Introduction	2
1.1	Features	2
1.2	Description	2
1.3	Specifications	3
2	Operation	4
2.1	5070 Front Panel.....	4
2.2	Test Connection	6
2.3	Operating Precautions.....	6
3	Warranty and Servicing	7

1 Introduction



1.1 Features

- Calibrate ductor testers and micro-ohmmeters
- 0.2, 2, 20, 200, 2000 mΩ ranges
- 5 point calibration: 0, 25, 50, 75, 100 %
- 0.1 % best accuracy
- Gold plated terminals
- Low thermal EMF connection
- Portable and robust carrying case

1.2 Description

The 5070 DuctorCal is a portable instrument suitable for calibrating high current ductor testers and micro-ohmmeters. It incorporates 5 sets of high current standard resistors that are used to enable precision calibration.

It has full 4 terminal capabilities with extra-large terminals for the current connection. Gold plated terminals are used throughout to reduce contact resistance and thermal EMFs. It has a substantial maximum continuous current rating, but can also be used with much higher transient/pulse test currents. The internal resistance standards are high quality manganin types with good long term stability and temperature coefficients.

Rugged and portable, the 5070 is ideal for site calibration work, housed in a safety yellow field case with carry handle.

1.3 Specifications

Resistance Range	Resistance values	Accuracy	Max current
200 $\mu\Omega$	50, 100, 150, 200 $\mu\Omega$	0.8 %	200 A
2 m Ω	0.5, 1, 1.5, 2 m Ω	0.5 %	100 A
20 m Ω	5, 10, 15, 20 m Ω	0.2 %	30 A
200 m Ω	50, 100, 150, 200 m Ω	0.1 %	10 A
2 Ω	0.5, 1, 1.5, 2 Ω	0.1 %	3 A

The currents shown above are the continuous rated for both AC and DC.

Higher currents (as generated by pulse driven instruments) can be used with an ON to OFF time ratio of 1:10 or less. The allowed peak currents are 10 times those specified above, with an upper limit of 1000 A and a maximum applied time of 4 seconds. At least 1 minute should be allowed between applications for cooling.

NOTE:

It is important to ensure there are adequate low resistance connections to the 5070 current terminals.

1.3.1 General Specifications

Dimensions..... W 540 x H 210 x D 410 mm

Weight..... 11 kg

1.3.2 Ordering Information

5070..... Ductor Tester and Micro-Ohmmeter Calibrator

C146..... Traceable calibration certificate (Factory)

C107..... Accredited calibration certificate (ISO 17025)

2 Operation

The front panel contains 5 rows of high-quality gold-plated terminals. All are suitable for 4 mm plug insertion on screw compression connectors. For current connection, large 25 mm diameter terminals are provided. The outer ring can be completely removed for clamp connections. Be aware that excessive tightening of the clamp can cause damage to the terminal thread

It is important that the correct good quality spade terminations are used for currents above 50 A since arcing can cause damage to the terminals.

Connections to the voltage terminals is less critical, but to minimise thermally generated EMF errors it is recommended that gold plated 4mm plugs are used.

Care should be taken to ensure that current is only injected into the two large current terminals; the voltage terminals are used only for the measurement of voltage.

2.1 5070 Front Panel

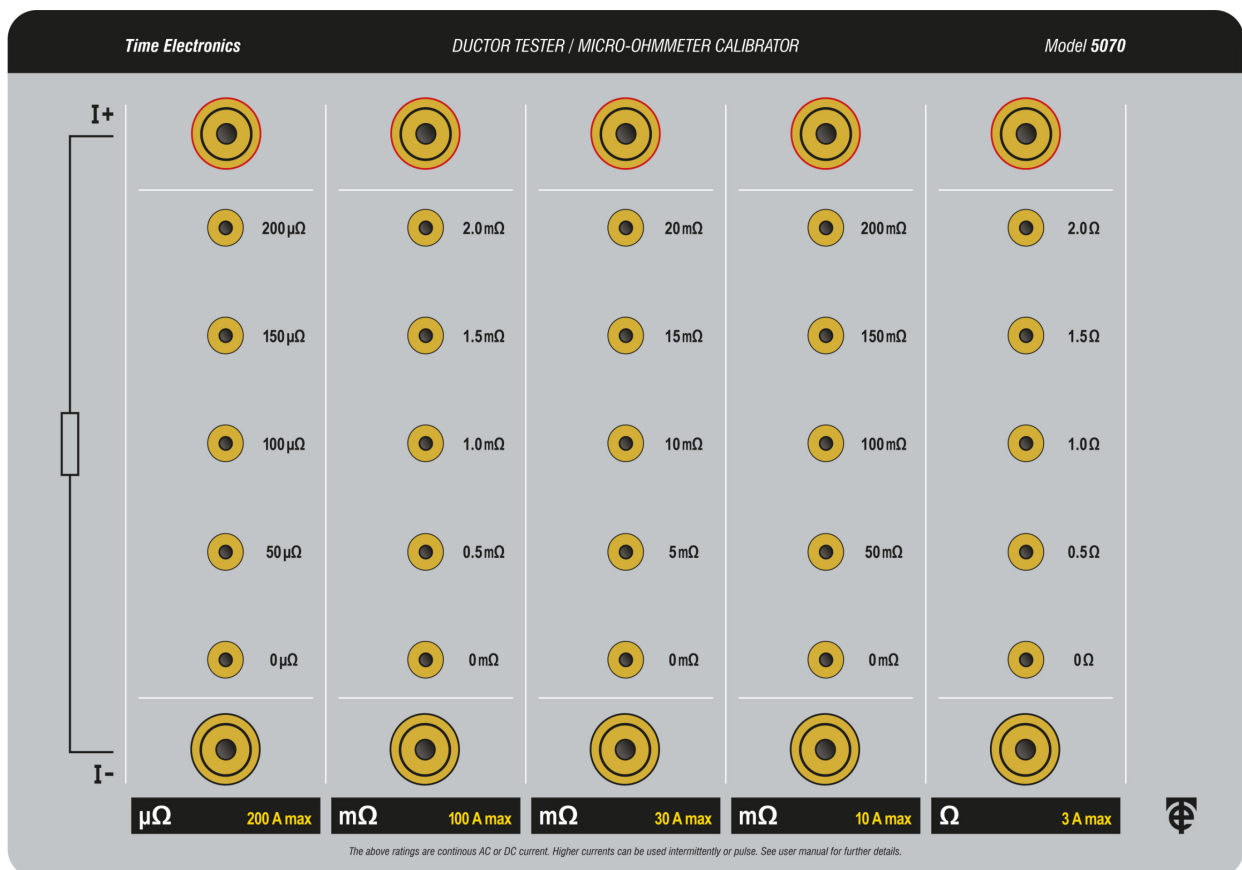

2.1.1 5070 Terminals

Example showing 200 $\mu\Omega$ range (200 A max) below. The voltage terminals are resistance set points that can be stepped through to perform 4-wire calibration of the unit under test. The 5070 has 5 independent ranges of resistance set points.

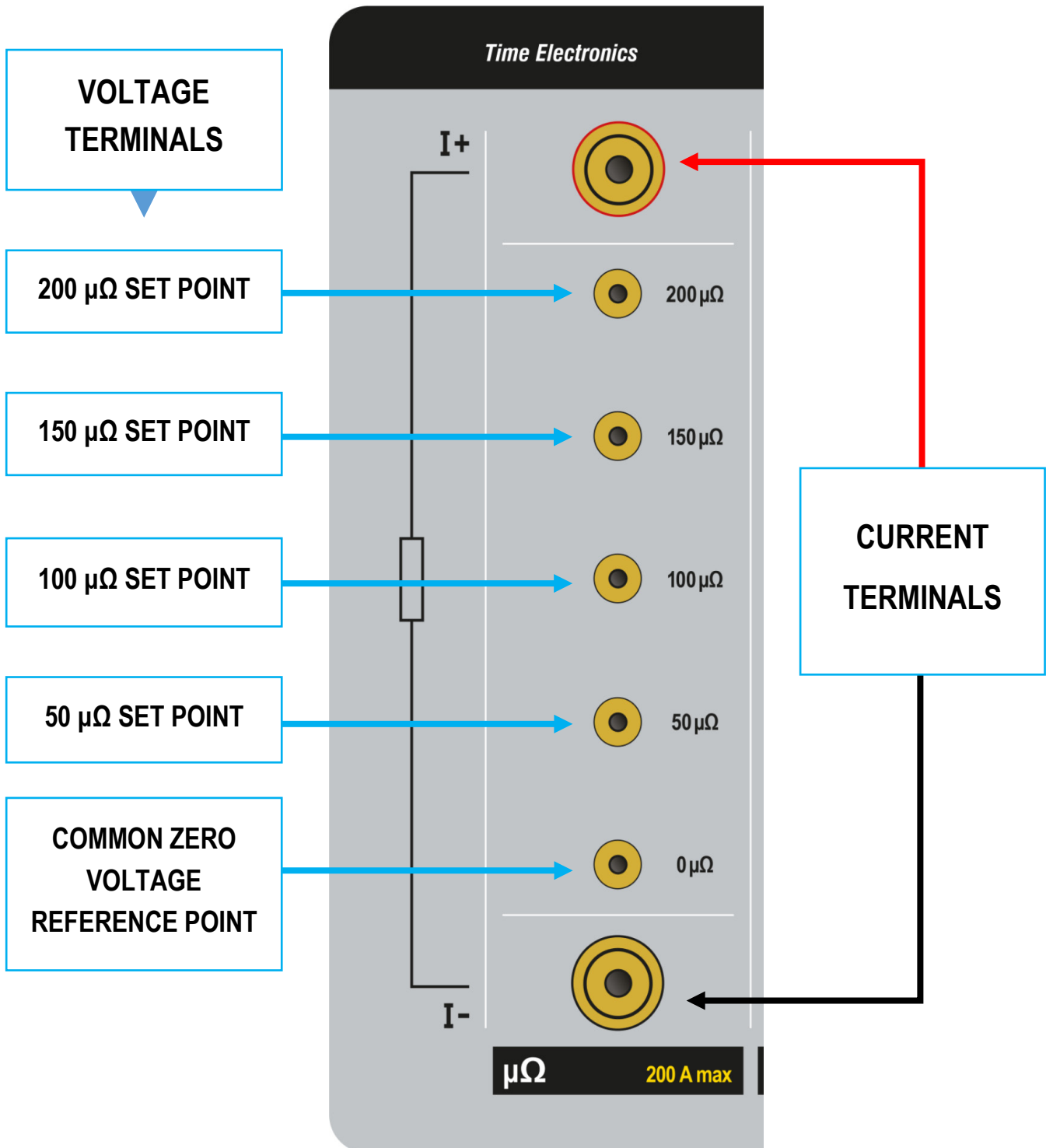

2.2 Test Connection

Below example for calibration of a micro-ohmmeter using the 200 $\mu\Omega$ range (200 A max).
The P1 connection can step through the set points, with P2 to common zero point.

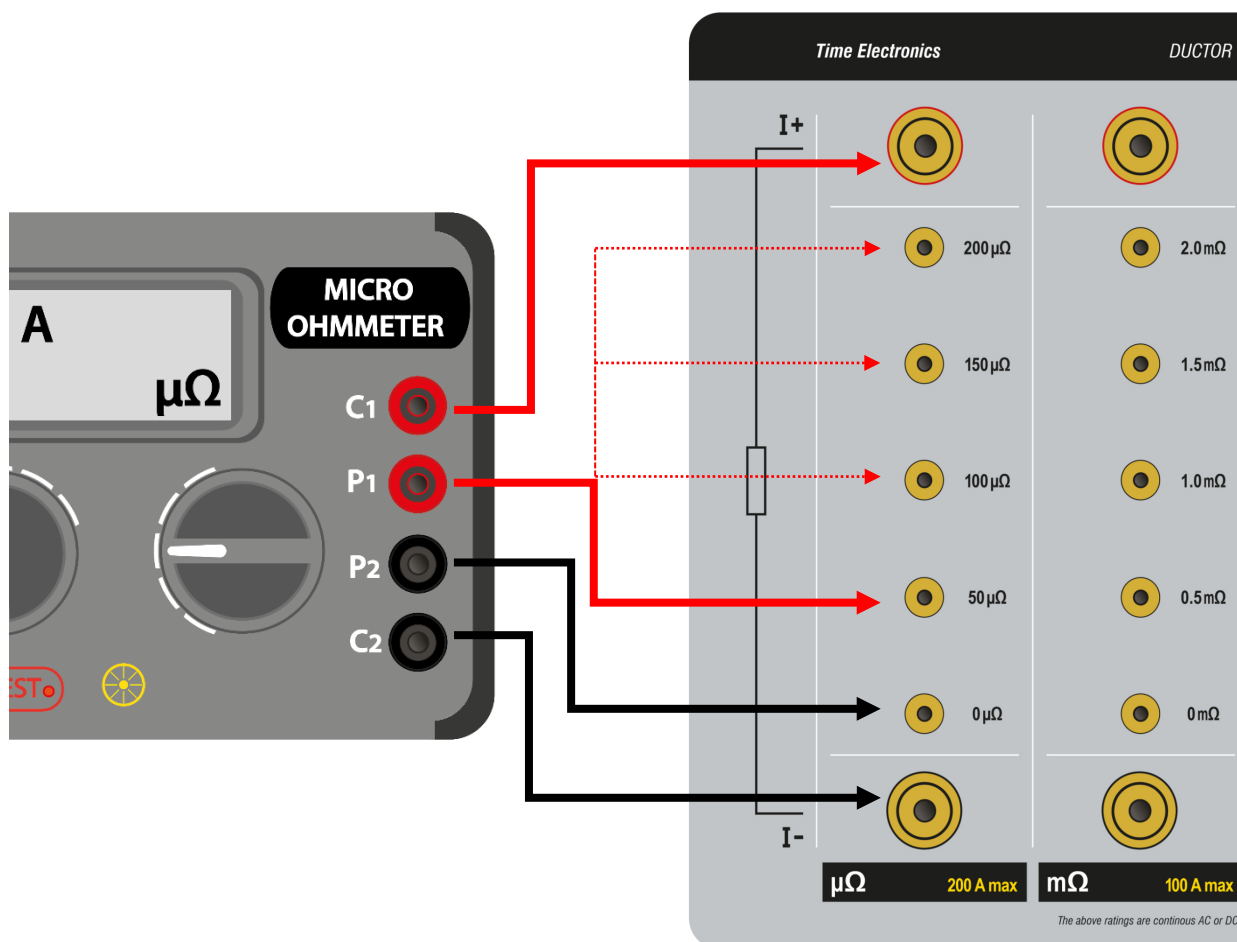

2.3 Operating Precautions

If thermal emfs are suspected the voltage terminal output should be checked on all positions with zero current flowing (current leads disconnected).

The zero position is checked with the voltage potential leads from the unit being calibrated, connected together on the 5070's '0' voltage terminal.

3 Warranty and Servicing

Warranty

Time Electronics products carry a one-year manufacturer's warranty as standard.

Time Electronics products are designed and manufactured to the highest standards and specifications to assure the quality and performance required by all sectors of industry. Time Electronics products are fully guaranteed against faulty materials and workmanship.

Should this product be found to be defective, please contact us using the below details. Inform us of the product type, serial number, and details of any fault and/or the service required. Please retain the supplier invoice as proof of purchase.

This warranty does not apply to defects resulting from action of the user such as misuse, operation outside of specification, improper maintenance or repair, or unauthorized modification. Time Electronics' total liability is limited to repair or replacement of the product. Note that if Time Electronics determine that the fault on a returned product has been caused by the user, we will contact the customer before proceeding with any repair.

Calibration and Repair Services

Time Electronics offers repair and calibration services for all the products we make and sell. Routine maintenance by the manufacturer ensures optimal performance and condition of the product. Periodic traceable or accredited calibration is available.

Contacting Time Electronics

Online:

Please visit **www.timeelectronics.com** and select Technical Support from the Contact links. From this page you will be able to send information to the Time Electronics service team who will help and support you.

By phone:

+44 (0) 1732 355993

By email:

mail@timeelectronics.co.uk

Returning Instruments

Prior to returning your product please contact Time Electronics. We will issue a return merchandise authorization (RMA) number that is to accompany the goods returning. Further instructions will also be issued prior to shipment. When returning instruments, please ensure that they have been adequately packed, preferably in the original packing supplied. **Time Electronics Ltd will not accept responsibility for units returned damaged.** Please ensure that all units have details of the service required and all relevant paperwork.

Send the instrument, shipping charges paid to:

Time Electronics Ltd

Unit 5, TON Business Park, 2-8 Morley Road,
Tonbridge, Kent, TN9 1RA.
United Kingdom.

Tel: +44(0)1732 355993

Fax: +44(0)1732 350198

Email: mail@timeelectronics.co.uk

Web Site: www.timeelectronics.com

Disposal of your old equipment

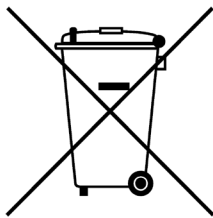

1. When this crossed-out wheeled bin symbol is attached to a product it means the product is covered by the European Directive 2002/96/EC.
2. All electrical and electronic products should be disposed of separately from the municipal waste stream via designated collection facilities appointed by the government or the local authorities.
3. The correct disposal of your old appliance will help prevent potential negative consequences for the environment and human health.
4. For more detailed information about disposal of your old appliance, please contact your city office, waste disposal service or return to Time Electronics.