



***Time Electronics***  
*Calibration, Test and Measurement*

# User Manual

Multifunction Calibrators

5051 Plus

7051 Plus

Version 2.1  
April 2021

## **Time Electronics Ltd**

Unit 5, TON Business Park, 2-8 Morley Road,  
Tonbridge, Kent, TN9 1RA, United Kingdom.

T: +44 (0) 1732 355993 | F: +44 (0) 1732 350198  
mail@timeelectronics.co.uk | www.timeelectronics.com

© 2021 Time Electronics Ltd.

All rights reserved.

Nothing from this manual may be multiplied, or made public in any form or manner, either electronically or hard copy, without prior written consent from Time Electronics Ltd.

This also applies to any schematics, drawings and diagrams contained herein.

This manual provides operating and safety instructions for the Time Electronics product. To ensure correct operation and safety, please follow the instructions in this manual.

Time Electronics reserves the right to change the contents, specifications and other information contained in this manual without notice.

# Contents

<b>1. Introduction</b>	<b>5</b>
1.1. Features	5
1.2. Calibration Capabilities	5
<b>2. Specifications</b>	<b>6</b>
2.1. Calibrator (Source)	6
2.2. 6.5 Digit Multimeter (measure)	6
2.3. 7051 Control Centre Details	7
2.4. 7051 General Specifications	7
2.5. 5051 Control Centre Details	8
2.6. 5051 General Specifications	8
<b>3. General Safety Precautions</b>	<b>9</b>
<b>4. General Operation Precautions</b>	<b>9</b>
<b>5. 7051 Plus</b>	<b>10</b>
5.1. Standard 7051Plus	10
5.2. 7051Plus With CCPAD Option	10
5.3. 7051 Terminal Panel	11
<b>6. 5051 Plus</b>	<b>12</b>
6.1. 5051 Plus Important Information	12
6.2. 5051 Terminal Panel	13
<b>7. Operation</b>	<b>14</b>
7.1. Operating the xx51 as a calibrator	15
7.2. DC Voltage	16
7.2.1. Setting the Output Value	17
7.2.2. DC Voltage Connection Diagram	18
7.2.3. HV interlock and ramping	19
7.2.4. Varying the Output Level	20
7.2.5. Using Deviation	20
7.2.6. Monitoring the Internal Temperature	22
7.3. DC Current	23
7.3.1. Current Output Terminals	23
7.3.2. DC Current Connection Diagrams	24
7.3.3. Output Error	25
7.3.4. High Current Interlock and Ramping	25
7.4. AC Voltage	26
7.4.1. Frequency Limits	26
7.4.2. HV Interlock and Ramping	26
7.4.3. Low Output Range – 20mV	26
7.4.4. AC Voltage Connection Diagrams	27

<b>7.5.</b>	<b>AC Current .....</b>	<b>28</b>
7.5.1.	AC Frequency Limits .....	28
7.5.2.	AC Current Connection Diagrams .....	29
<b>7.6.</b>	<b>R-G-C-L Function Selection.....</b>	<b>30</b>
7.6.2.	R-G-C-L Connection Diagram .....	31
7.6.3.	Decade Resistance .....	32
7.6.4.	Full Range Resistance .....	33
7.6.5.	Conductance .....	34
7.6.6.	Capacitance .....	35
7.6.7.	Inductance.....	36
<b>7.8.</b>	<b>Temperature Simulation Selection.....</b>	<b>37</b>
7.8.1.	PRT Simulation .....	38
7.8.2.	Thermocouple Simulation.....	39
<b>7.9.</b>	<b>Oscilloscope Calibration.....</b>	<b>41</b>
7.9.1.	Amplitude .....	42
7.9.2.	Amplitude (50 ohm).....	43
7.9.3.	Time Markers / Period .....	44
7.9.4.	Frequency .....	45
7.9.5.	Duty Cycle.....	46
7.9.6.	Bandwidth (via fast rise).....	47
7.9.7.	GHz Sweep .....	49
<b>7.10.</b>	<b>System Information.....</b>	<b>50</b>
<b>7.11.</b>	<b>Operating the xx51 as a Multimeter .....</b>	<b>51</b>
7.11.1.	Selecting Measurement Function .....	51
7.11.2.	Selecting Range.....	52
7.11.3.	Selecting Display Resolution.....	52
7.11.4.	Reading Hold.....	53
7.11.5.	Nulling a Reading .....	53
7.11.6.	Thermocouples and CJC.....	53
7.11.7.	Exiting xx51 Multimeter Mode .....	53
<b>8.</b>	<b>EasyCal Software .....</b>	<b>54</b>
<b>9.</b>	<b>7051 Pressure Control Centre.....</b>	<b>55</b>
9.1.	Controls.....	56
<b>10.</b>	<b>Included Accessories .....</b>	<b>57</b>
10.1.	Using the 9780 Clamp Meter Adaptor.....	59
10.2.	7112 Transducer Patch Box (7051 Only).....	60
10.3.	7051 CCPAD Option .....	61
<b>11.</b>	<b>Re-Calibration.....</b>	<b>62</b>
<b>12.</b>	<b>Fault Diagnosis .....</b>	<b>62</b>
12.1.	Fault Check List.....	62
<b>13.</b>	<b>Warranty and Servicing .....</b>	<b>63</b>

**NOTE:** The 7051 Plus / 5051 Plus are a packages that includes specific options for a wide workload coverage. This manual will refer to the 7051 or 5051 in certain sections as an abbreviation.

Where instructions apply to both the 5051 and 7051, the term xx51 will be used.

# 1. Introduction

The xx51Plus combines a high accuracy calibration source with a precision digital multimeter. It incorporates a wide range of internally fitted functions to provide users with a multi product calibration solution. It is suitable for rapid calibration with automated test runs using EasyCal software, covering electrical test tools, process instrumentation, oscilloscopes and more. Adaptors and accessories are included for specific applications such as clamp meter and optical tachometer calibration. Supplied test leads enable the necessary connections for nearly all applications.

**Calibrator:** Provides a wide range of calibrated outputs for AC/DC voltage and current, resistance, capacitance, inductance, RTD and thermocouple simulation.

**Multimeter:** The integral 6½ digit multimeter measures DC voltage to 1000V, AC voltage to 750V, resistance to 100MΩ, and frequency to 300kHz.

**Control Centre:** A intuitive user interface with large 12.1" touch screen display (10.4" on 5051+). The control centre is a PC with a 64 bit dual core processor, running Windows 10. As standard it features the calibrator and multimeter control applications, with the wide range of functions easily selectable using mouse, keyboard or touch screen.

**EasyCal:** Enables automatic calibration to increase speed and efficiency of work. In addition, EasyCal has features to manage and administrate both inventory and quality control. To complement the system a printer and connectivity kit is supplied as standard, for generation of certificates and reports. Further supplied accessories include a bar code reader for quick identification of devices in EasyCal, and label printer for creating stickers and labels to be placed on instruments.

**Communication:** Using EasyCal the operator can read back from compatible electrical, temperature, pressure, and loop modules within the bench. EasyCal can also be used with external instruments such as dry block calibrators and portable test instruments available.

## 1.1. Features

- Integral multifunction calibrator and 6.5 digit multimeter
- Touch screen PC control centre with 10.4" or 12.1" display
- Source up to 1050V AC/DC voltage
- Source up to 22A AC/DC current
- Source resistance (up to 1 GΩ), capacitance and inductance
- Oscilloscope calibration and optional power calibration
- Measure voltage, current, resistance, frequency
- Thermocouple and PT100 simulation and measurement
- EasyCal software, adaptors and accessories included
- Communicate with EasyCal compatible modules

## 1.2. Calibration Capabilities

- Multimeters, clamp meters, ohmmeters, AC/DC signal sources
- Decade boxes, data loggers, RCL meters
- Tachometers, oscilloscopes, frequency counters, timer counters
- Frequency meters, watt meters, power meters, current probes
- Thermocouples, RTDs, Thermometers, PRTs, thermistors
- Temperature indicators, recorders, controllers, switches
- Loop and process calibrators

## 2. Specifications

### 2.1. Calibrator (Source)

Function	Range / Values	Best 1 Year Specification
Voltage DC	0 to $\pm$ 1050V	$\pm$ 15ppm of setting
Current DC	0 to $\pm$ 22A	$\pm$ 80ppm of setting
Voltage AC	1mV to 1050V (10Hz to 1MHz, sine-wave)	$\pm$ 300ppm of setting
Current AC	10 $\mu$ A to 22A (20Hz to 1kHz, sine-wave)	$\pm$ 0.05%
Clamp Meter Adaptor x50 turn	AC/DC Current up to 1100A (DC, 45 to 90Hz)	$\pm$ 0.5%
Capacitance	1nF, 10nF, 100nF, 1 $\mu$ F, 10 $\mu$ F, 100 $\mu$ F (100V Max)	$\pm$ 0.25%
Inductance	1mH, 1.9mH, 5mH, 10mH, 19mH, 50mH, 100mH, 190mH, 500mH, 1H, 10H	$\pm$ 0.1%
Decade Resistance	1 $\Omega$ to 1G $\Omega$ (decade values)	$\pm$ 20ppm of setting
Full Range Resistance	1 $\Omega$ to 120M $\Omega$ (variable)	$\pm$ 100ppm of setting
Conductance	1s to 1ns (fixed values, decade steps)	$\pm$ 20ppm of setting
Thermocouple Simulation	-270 to 1820°C (type J, K, R, T, S, B, E, N)	$\pm$ 0.15°C
PT100 Simulation	-180 to 850°C	$\pm$ 0.07°C
<b>Oscilloscope Calibration</b>		
Amplitude	6mV to 200V and 6mV to 2V 50 $\Omega$ (Square-wave or DC)	$\pm$ 0.05%
Frequency/Period	0.1Hz to 100MHz / 10ns to 10s (fixed values 1, 2, 5 sequence)	$\pm$ 0.1ppm (0.1Hz to 10MHz / 100ns to 10s) $\pm$ 20ppm (20, 50, 100MHz / 50, 20, & 10ns)
Duty Cycle	3 frequencies: 100Hz, 1kHz, 10kHz, settable from 0 to 100%	–
Fast-Rise	< 400ps. Bandwidth checking up to 400MHz	–
Option 9769: Scope 2.2GHz Sweep	100MHz to 2.2GHz levelled sine-wave (0.5, 1, 1.5V pk-pk)	Amplitude $\pm$ 1% Frequency $\pm$ 20ppm

### 2.2. 6.5 Digit Multimeter (measure)

Function	Range / Values	Best 1 Year Specification
Voltage DC	0 to 1000V	35ppm of rdg + 6ppm of rng
Current DC	0 to 3A	500ppm of rdg + 50ppm of rng
Voltage AC	0 to 750V	0.06% of rdg + 0.04% of rng
Current AC	0 to 3A	0.1% of rdg + 0.04% of rng
Resistance	0 to 100M $\Omega$	100ppm of rdg + 50ppm of rng
Frequency	3Hz to 300kHz	0.01% of rdg
Thermocouple	-270 to 1800°C (Type J, K, R, T, S, B, E, N)	$\pm$ 0.5°C
PT100	-180 to 850°C	$\pm$ 0.08°C

*Note: See extended specifications data sheet for full technical data.*

## 2.3. 7051 Control Centre Details

Feature	Specifications
Processor	64 bit, dual core (or equivalent)
RAM	16GB
Hard Drive	120GB Solid State (or higher)
Ports	Front: 4 x USB / Rear: 2 x USB, 2 x RS-232
Display	12.1" Touch Screen LCD
Operating System	Windows 10
Pre loaded Software Programs	7051 Manual Control Applications (Calibrator and Multimeter), EasyCal Software
Keypad Module Option	CCPAD: Control Centre numeric keypad module with jog dial For input/control of manual calibration applications & EasyCal software on the control centre.
Supplied Hardware/Accessories	USB keyboard and mouse, Inkjet Printer, Cal and ID Label Printer, 4 port USB hub, Numeric key pad, USB memory stick, bar code reader, label printer
Control Centre Operated Module Options	Pressure: XTEG Gauge/Differential/Compound modules (EasyCal software compatible) Frequency: CCScope Oscilloscope Modules / CC-FRQC Frequency Counter Module
Modules with EasyCal Communication	8030B Pressure Controllers / MTEG/RMTEG Pressure Calibrators / 5065B and 5075B DMMs 7085A Temperature Distribution Module / 7002/7003/7004 Process Communicators / 8029 Electronic Load / 5030B Electrical Tester Calibrator
External Products with EasyCal Communication	TEG Digital Pressure Gauges / Dry Block Calibrators
EasyCal Software Add-ons and Options	9779: Job and Address Label Printer / EC2FL/EC2WL: Additional User Licenses for separate PCs EAD: EasyAdmin Add-On / CREP: Crystal Reports Software

## 2.4. 7051 General Specifications

Environmental	Specifications/Details
Warm up	30 minutes to full accuracy
Settling Time	Less than 5 seconds
Temperature Performance	Operating: 5 to 45°C. Full Spec: 22°C +/- 3°C. Storage: -10°C to 50°C
Operating Humidity/Altitude	<80% non condensing. Altitude: 0 to 3km. Non operating: 3km to 12km
Line Power	100 to 230V AC 50/60 Hz. 200W maximum
Dimensions	W425mm (507mm with CCPAD option), H201mm (primary console fitting only)

## 2.5. 5051 Control Centre Details

Feature	Specifications
Processor	64 bit, dual core (or equivalent)
RAM	4GB (or higher)
Hard Drive	120GB Solid State (or higher)
Ports	4 x USB, 1 x Fast Ethernet
Display	10.4" Touch Screen LCD
Operating System	Windows 10
Pre loaded Software Programs	5051 Manual Control Applications (Calibrator and Multimeter), EasyCal Software
Supplied Hardware/Accessories	USB keyboard and mouse, Inkjet Printer, Cal and ID Label Printer, 4 port USB hub, Numeric key pad, USB memory stick, bar code reader, label printer

## 2.6. 5051 General Specifications

Environmental	Specifications/Details
Warm up	30 minutes to full accuracy
Settling Time	Less than 5 seconds
Temperature Performance	Operating: 5 to 45°C. Full Spec: 22°C +/- 3°C. Storage: -10°C to 50°C
Operating Humidity/Altitude	<80% non condensing. Altitude: 0 to 3km. Non operating: 3km to 12km
Line Power	220 to 230V AC 50 Hz or 110 to 120 V 60 Hz. 200W maximum
Dimensions / Weight	W430mm, H202mm, D538mm. Weight: 23kg



### 3. General Safety Precautions



**High Voltage:** The xx51 can produce **1050 V** and users should be aware of the dangers involving serious electrical shock.



**High Current:** The xx51 can produce **22 Amps** and users should be aware of the power levels involved. Equipment connected to the 5051 should be capable of withstanding the currents involved without damage. High current outputs, greater than 10A, should not be left on for periods longer than 10 minutes.

### 4. General Operation Precautions

Prior to using the xx51, the following precautions and recommendations should be noted.

- The xx51's outputs are protected against short circuit, but serious internal damage can occur if voltage or current is injected into output terminals.
- The xx51's output terminals are floating with respect to mains earth (the green terminal on the front panel). The negative output terminals can be allowed to rise to a maximum of +/-75V with respect to earth. For certain calibrations it will be found beneficial to earth the low (negative) output terminal. This will prevent noise pickup and will generally improve the stability of readings if the unit under calibration is not earthed.
- Earthing the xx51's high (positive) terminals is prohibited.
- The user should always be aware of the dangers of high voltage. The xx51 can produce 1000V AC, which is approximately 1600V peak. Voltages of this level present a serious electrical shock hazard to the user. Care should be taken to ensure that voltages above 50V are switched off before the user touches the test leads.
- Certain types of equipment will be found to be susceptible to electrical noise pickup at the frequency of the main power supply. Generally, this sort of equipment should be calibrated at a different frequency.
- The precision resistors used for the passive resistance function are suitable for operation at low currents. Care should be taken not to overload them, since permanent damage can result. The max allowed currents are, 10mA up to 1k $\Omega$ , 1mA for 1k – 10k $\Omega$ , 0.1mA for 10k – 100k $\Omega$ , and 10uA above 100k $\Omega$ .
- When using the high current (20A) terminals, ensure that good quality low contact resistance connectors and leads with adequate current carrying capability are used. The 9542 General Purpose Test Leads are rated to 32 A and designed for this application.
- To clean use an alcohol-free wipe such as a 'durable screenclean 50'

## 5. 7051 Plus

### 5.1. Standard 7051Plus

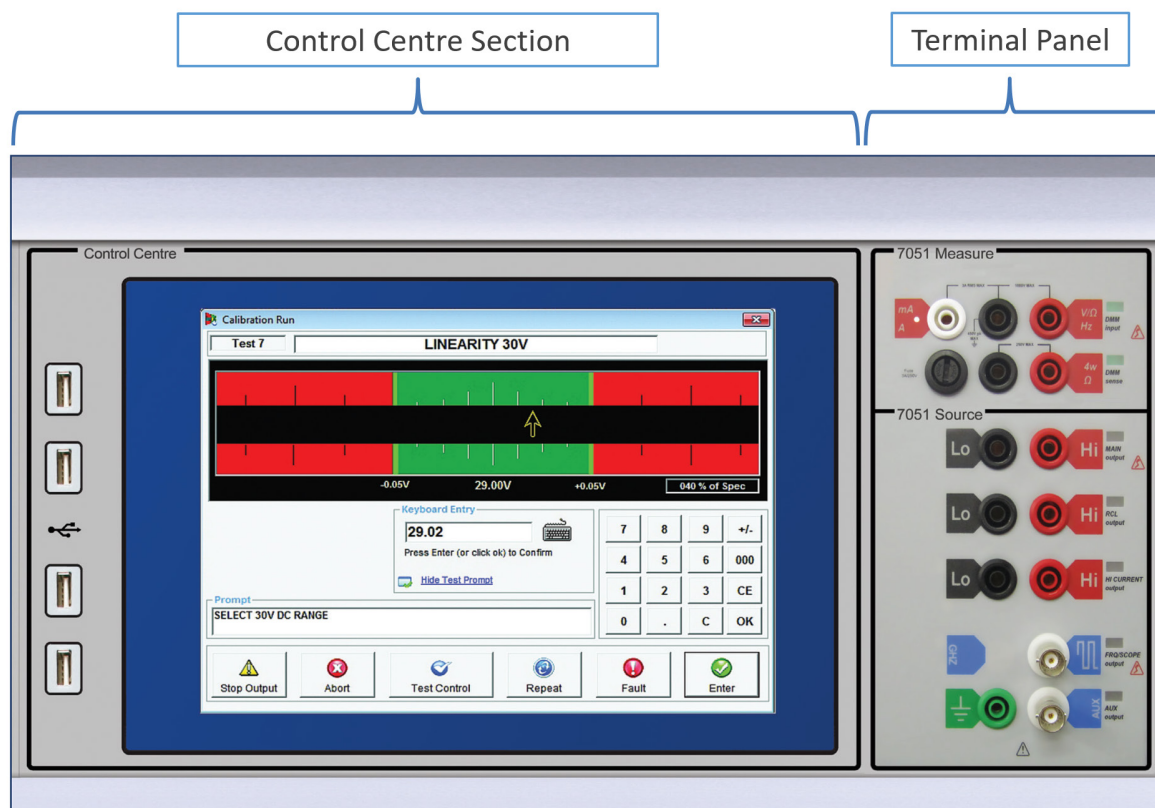

### 5.2. 7051Plus With CCPAD Option

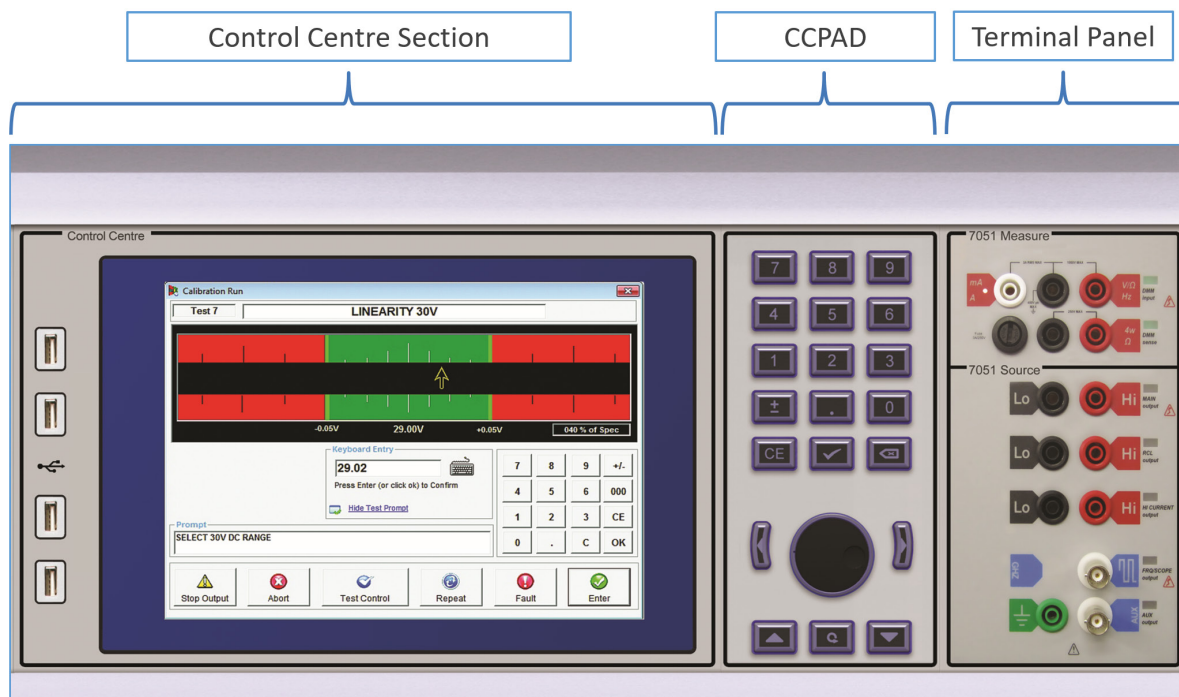

The CCPAD is a module designed to accompany the CalBench control centre, for use with the manual control programs and EasyCal calibration software.

### 5.3. 7051 Terminal Panel

The terminal panel locates to the right side of the control centre module and features a Measure and Source section.

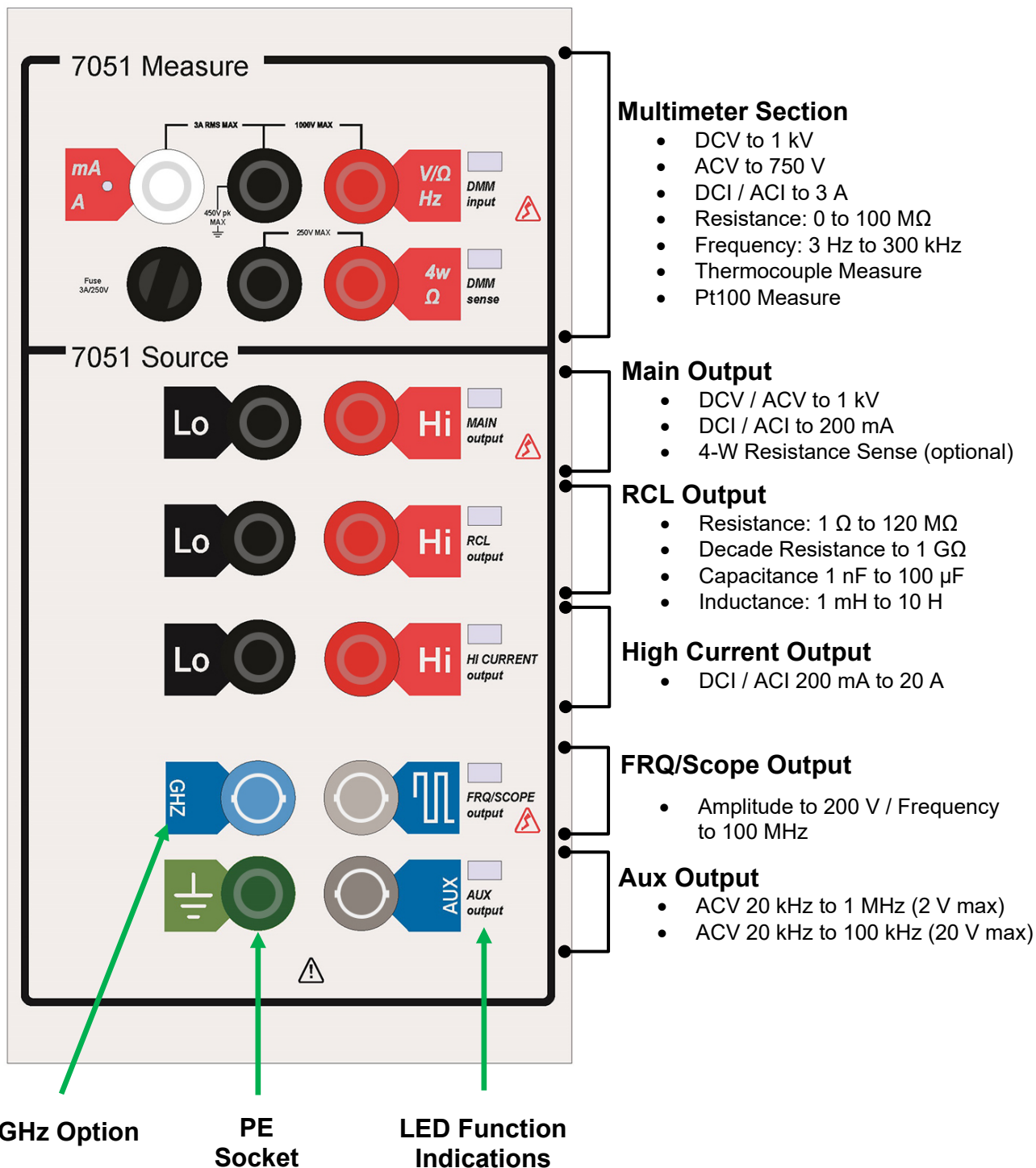

## 6. 5051 Plus



### 6.1. 5051 Plus Important Information



**Warning:** The 5051 is a heavy instrument and care should be taken when lifting to prevent injury. Use both handles to carry.

**Warning:** If this equipment is used in a manner not specified by the manufacturer, the protection provided by the equipment may be impaired. This instrument must be connected to a grounded outlet.

**This instrument is to be serviced by trained personnel only.**

**Disconnect mains supply before removing cover or replacing fuses.**

For operations involving removal of the 5051's cover, users should be aware that certain sections of the circuitry carry high voltages, which are hazardous. Very high currents causing burns can also be generated if certain terminals are inadvertently shorted.

#### Locating the Instrument.

For bench-top use, make sure the instrument is located on a flat, firm surface. The instrument is fitted with four plastic feet. The two front feet can be adjusted to 'tilt' the instrument.

A 10 cm area of free space is recommended at the rear of the instrument. Do not obstruct the fan inlet on the rear of the unit. Do not obstruct any exhaust outlets on the bottom of the instrument.

***Please retain the shipping case for future use e.g. transport of 5051 for calibration.***

#### Powering the Instrument.

Before connecting power to the 5051 for the first time, please ensure that it has been set to accept the correct voltage. 100/120V 60Hz operation is an option and specified on ordering.

The supply power is connected via a standard IEC Euro connector on the rear panel. The standard voltage supply is 220/230V 50Hz. There two protection fuses mounted on the rear panel next to the IEC connector, both are 3.15A slow blow.

## 6.2. 5051 Terminal Panel

### Multimeter Section

- DCV to 1 kV
- ACV to 750 V
- DCI / ACI to 3 A
- Resistance: 0 to 100 MΩ
- Frequency: 3 Hz to 300 kHz
- Thermocouple Measure
- Pt100 Measure

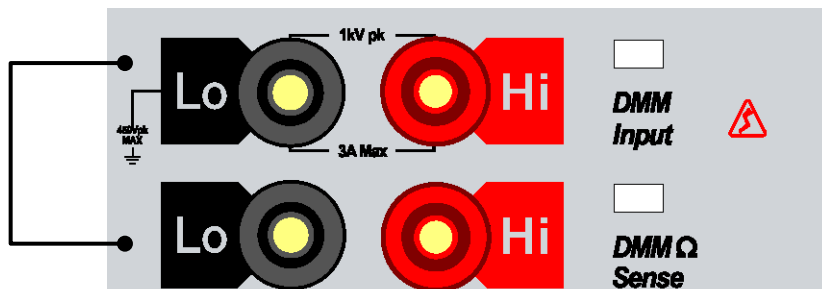

### Main Output

- DCV / ACV to 1 kV
- DCI / ACI to 200 mA
- 4-W Resistance Sense (optional)

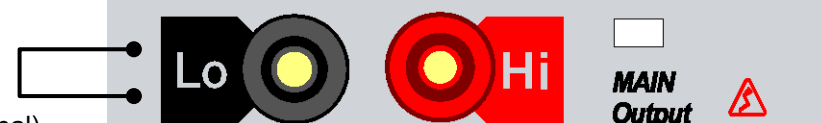

### RCL Output

- Capacitance 1 nF to 100 μF
- Inductance: 1 mH to 10 H
- Decade Resistance to 1 GΩ
- Full Resistance: 1 Ω to 120 MΩ

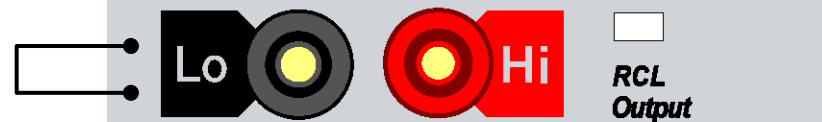

### High Current Output

- DCI / ACI 200 mA to 20 A

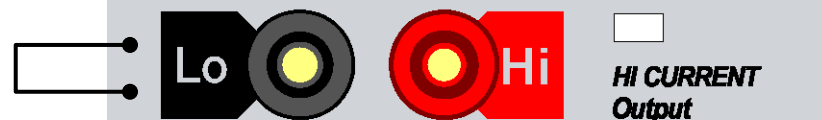

### GHz Sweep (Option)

- 100 MHz to 2 GHz Sine wave

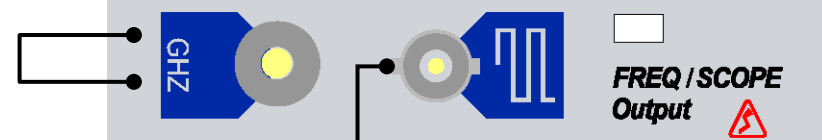

### Protective Earth (PE)

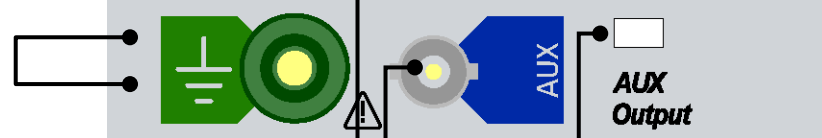

### FRQ/Scope Output

- Amplitude to 200 V / Frequency to 100 MHz

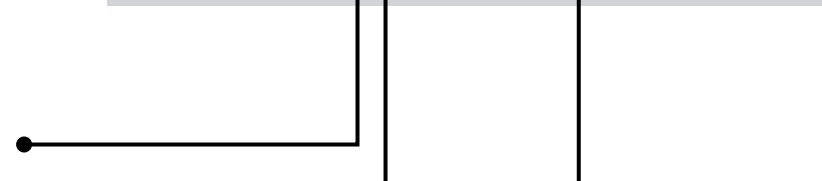

### Aux Output

- ACV 20 kHz to 1 MHz (2 V max)
- ACV 20 kHz to 100 kHz (20 V max)

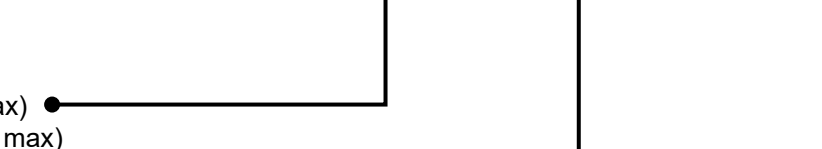

### LED Terminal Indicators



## 7. Operation

After completing the power-up initialisation the Control Centre will show the conventional Windows desktop on the screen. The start menu is set up for the following applications:

### EasyCal

- EasyEdit
- CalRun
- PrintCert
- EasySupport

### Control Apps

- Calibrator Control (Source)
- DMM Control (Measure)

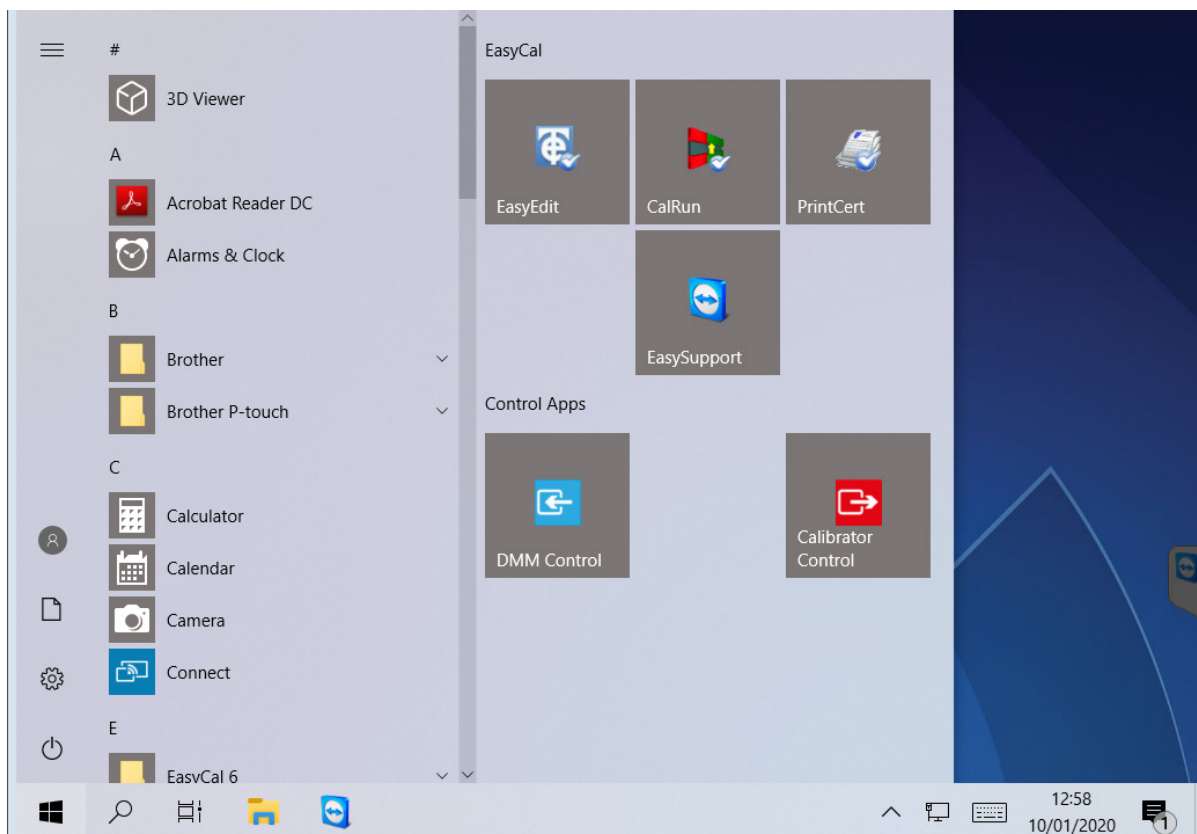

## 7.1. Operating the xx51 as a calibrator

To use the xx51 as a high accuracy calibration source, click or touch the xx51 calibrator icon from the start menu. The program will initialise the xx51 before entering the FUNCTION selection screen which shows the main functions of the xx51:

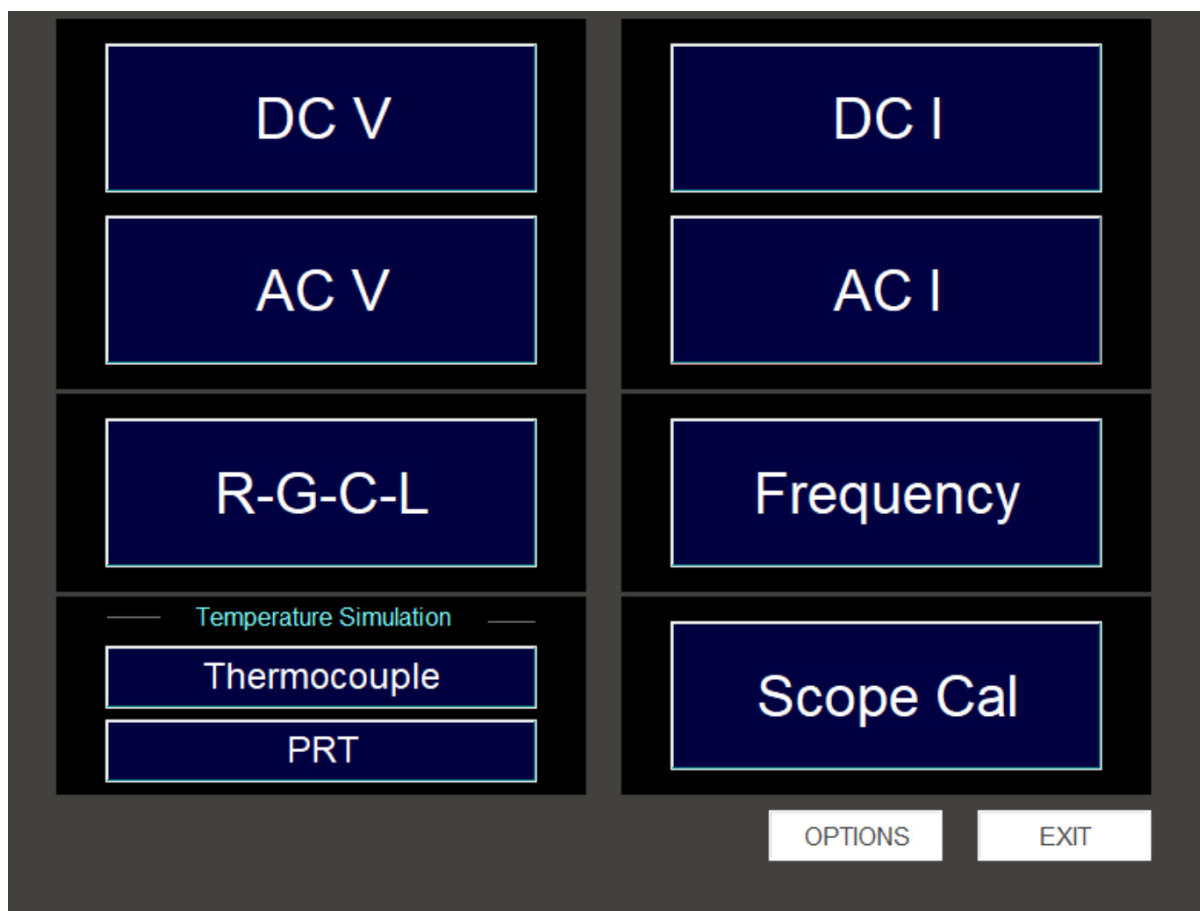

The **Options** button provides access to various system set up parameters and general information about the xx51.

The **Exit Application** button terminates the program and returns to Windows desktop

## 7.2. DC Voltage

DC V

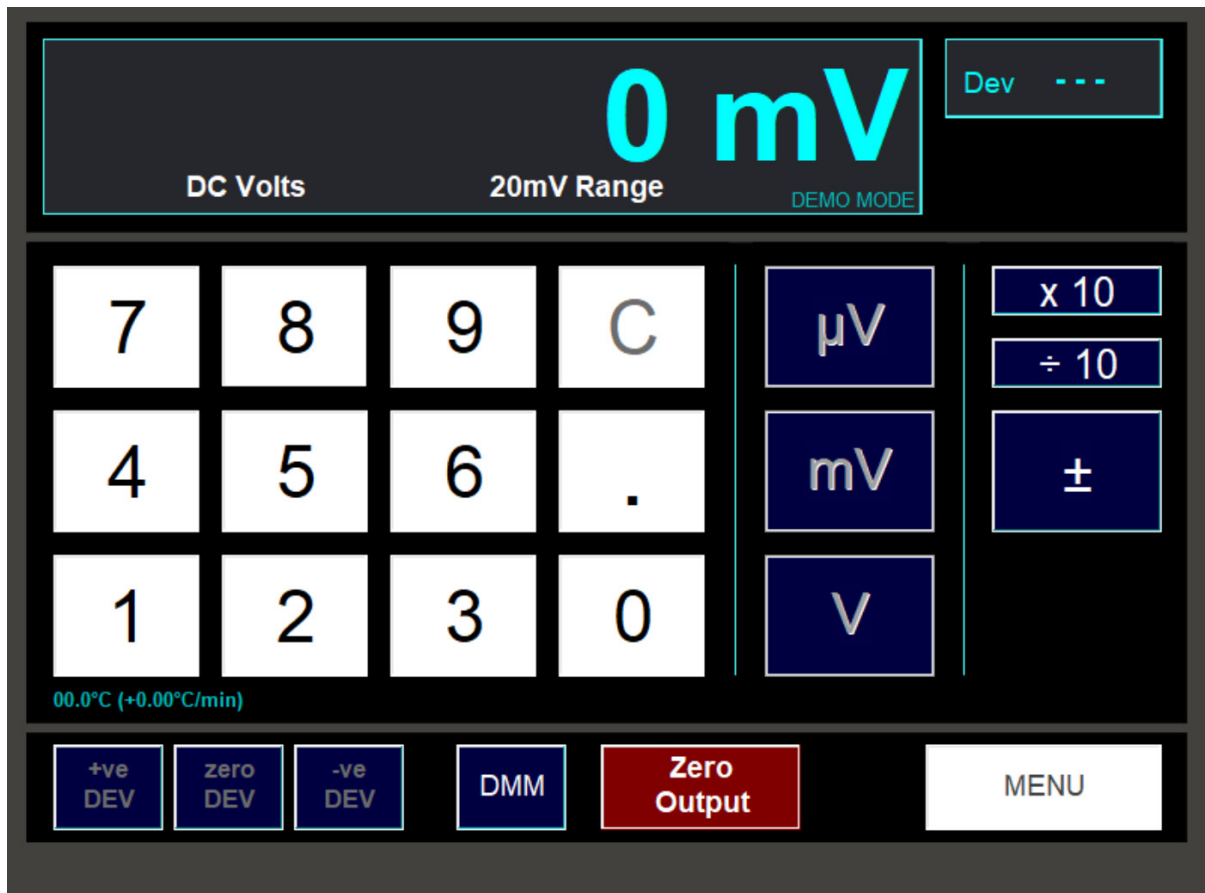

At the top of the screen is a sub window, which displays in large characters the output value and units. In small characters below are shown the range and function selected.



### 7.2.1. Setting the Output Value

DC V

Please note, at all times, pressing the **Zero Output** button will set the output terminals to 0V.

A conventional numeric keypad is used for setting the output. Enter the value required using the digit buttons. Alter the polarity of the value using the +/- button. During entry, use the **C** button to delete the last digit entered, or hold down the **C** button for a second to delete all the entered digits.

Finally press one of the unit buttons, i.e. **µV**, **mV** or **V**. The selected output value will now be present on the output terminals.

Note, the unit will automatically select the appropriate range according to the output value entered. The changeover point is 10% above the nominal full scale for DC ranges, and 1% for AC ranges, e.g. the 2V DC range extends to 2.2V, any selection above 2.2V and less than 22V will automatically switch to the 20V range.

The maximum output selectable in DCV mode is +/-1050V. If you enter a value greater than this, the following message will appear for a few seconds and the output will not be set:

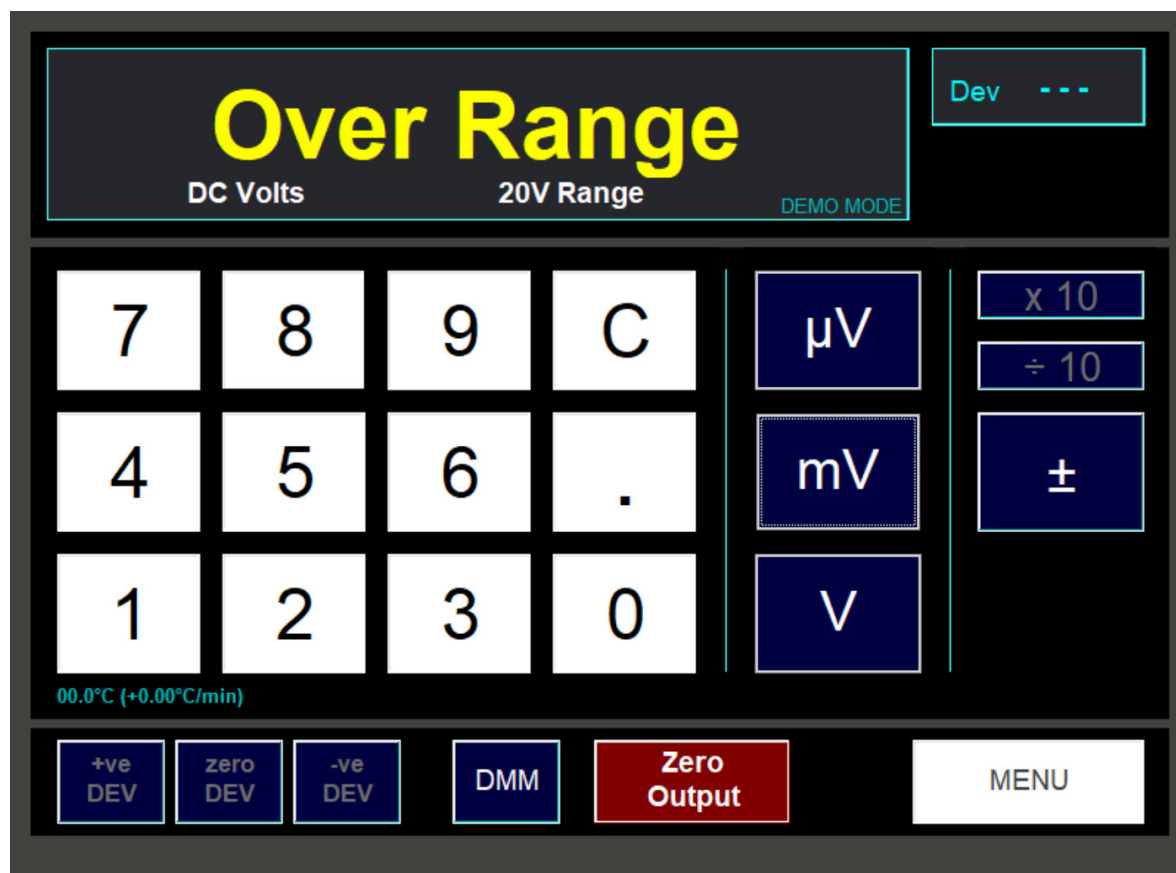

### 7.2.2. DC Voltage Connection Diagram

DC V

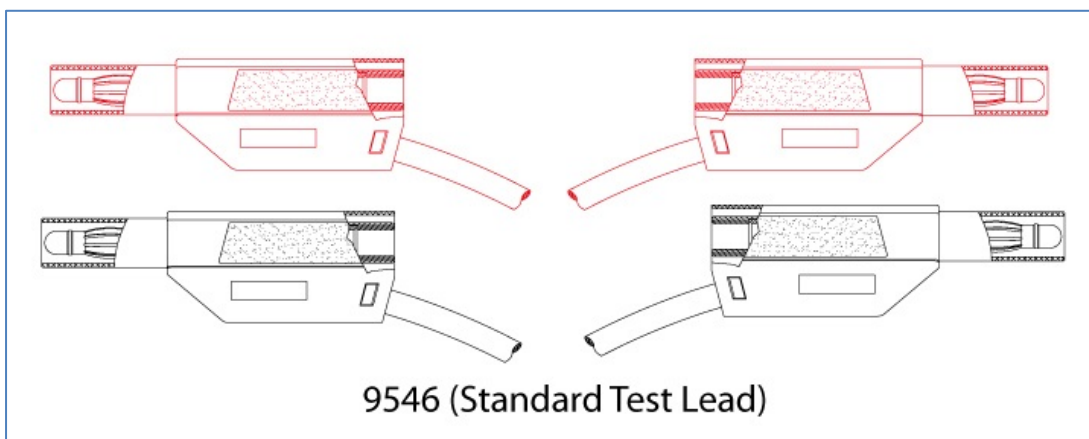
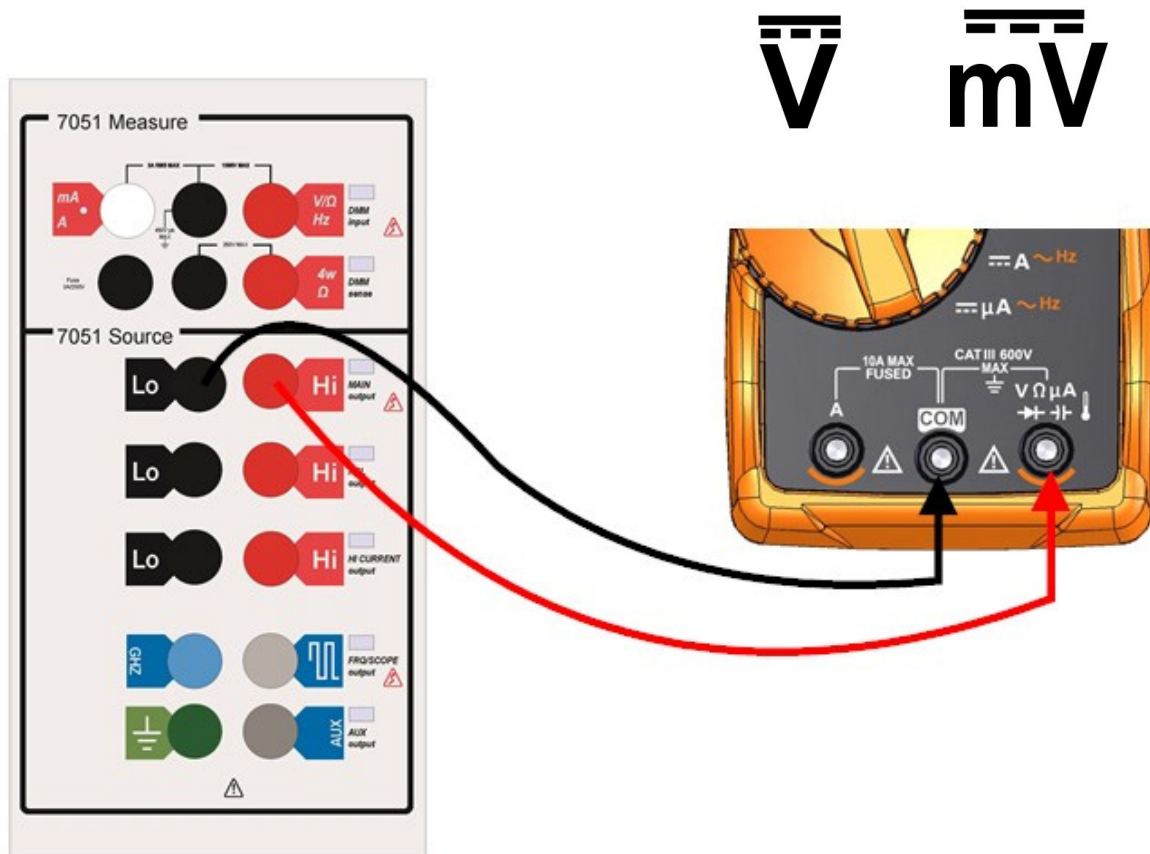

### 7.2.3. HV interlock and ramping

DC V

A safety interlock feature is incorporated to ensure that user must undertake an additional operation when voltages about 40V are selected.

To prevent potential damage to equipment being calibrated, large changes in the voltage setting cause the xx51 to change the output by a controlled ramp (instantaneous change is not permitted).



Press **OK** to confirm the output or **Cancel** to return to the previous output setting.

In addition, if the voltage selected is 100V (or more) greater than the present output level, ramping of the voltage will occur at approximately 200V per second. During this process, the following window will be displayed:



Note, if necessary you may use the **Stop Output** button during ramp up to immediately set the output voltage to zero.

Ramping down of the voltage will occur if the requested new output level is 100V (or more) lower than the present output. This window will be displayed during ramp down:



### 7.2.4. Varying the Output Level

DC V

Once an output level has been set, it may be varied in the following ways:

- Its polarity can be toggled using the +/- button
- Its value can be multiplied by 10 or divided by 10 using the **x10** and **/10** buttons (if required, the range will change automatically)
- Pressing the **Zero Output** button will set the output to zero volts
- Entering a new output level using the numeric keypad. The output will remain unchanged until a unit button is pressed
- Using deviation to vary the output level by up to +/-10%, described below

### 7.2.5. Using Deviation

The top right sub window shows the amount of deviation that has been applied to the output. If no deviation has been applied, zero deviation is indicated in this window by 3 dashed lines.

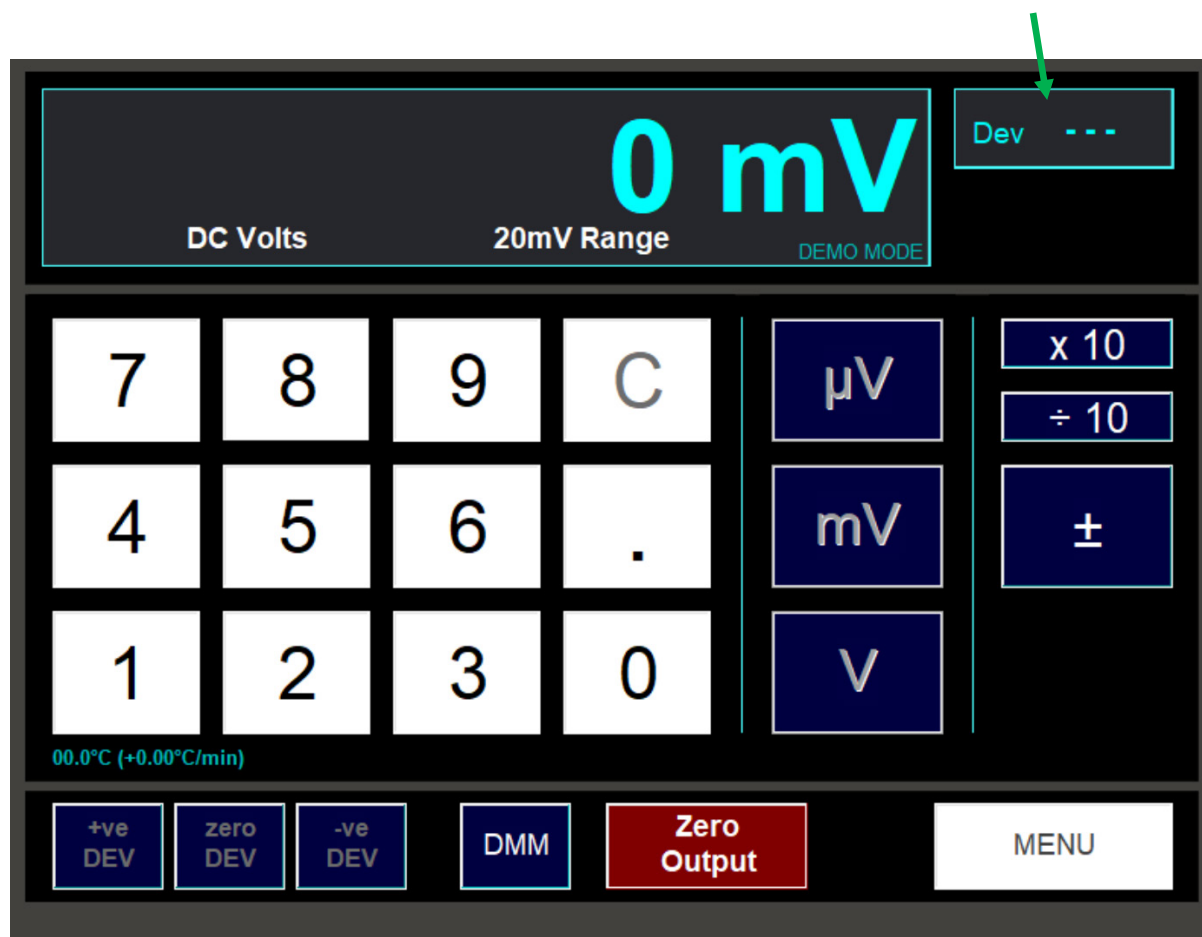

Note, you can only set a deviation if the output level is non-zero.

DC V

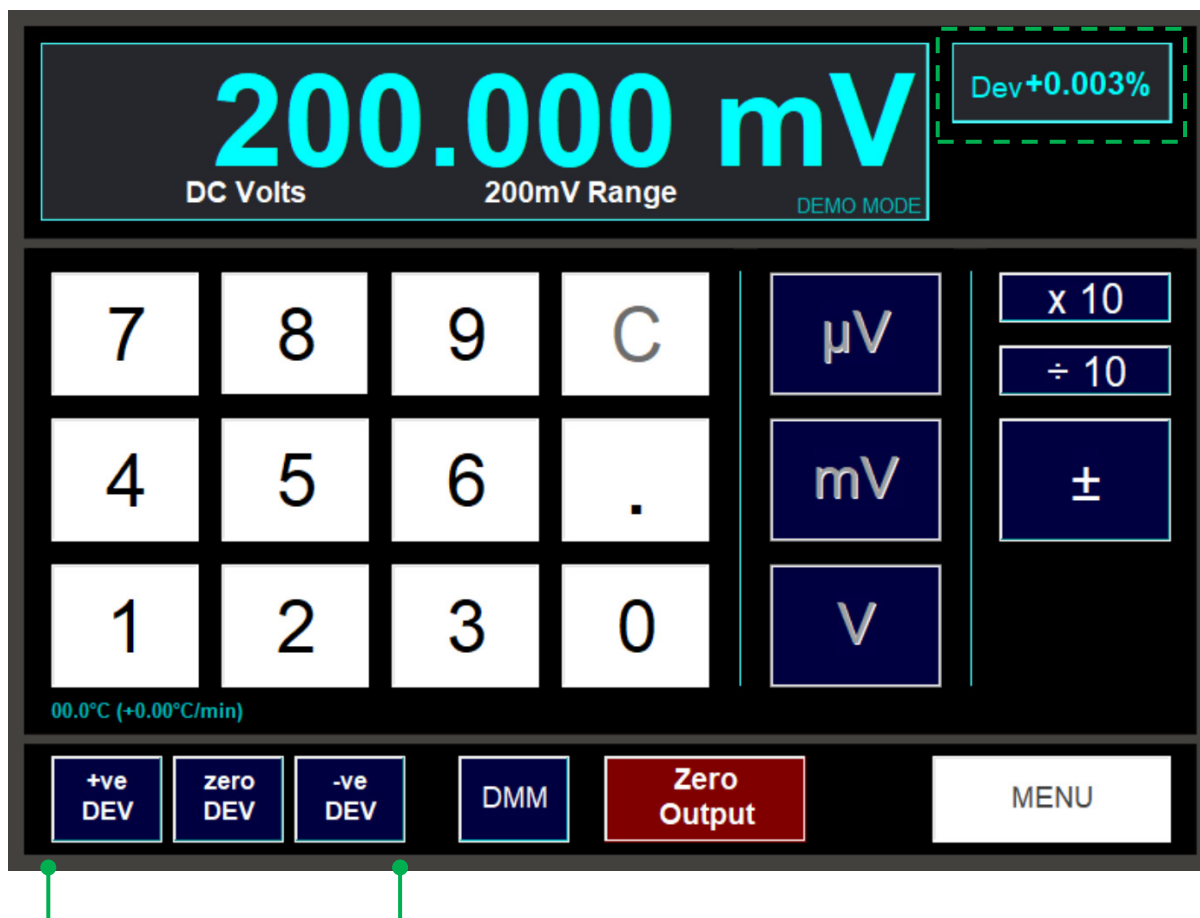

To apply a positive amount of deviation, use the **+ Dev** button.

To apply a negative amount of deviation, use the **- Dev** button.

Clicking and releasing either button once will step the deviation by one count, i.e. +/-0.001%. Alternatively, holding down either button will begin increasing or decreasing continuously. Release the button when the amount of deviation required has been reached.

Use the **Zero Dev** button to reset the amount of deviation to zero.

Note, if you try to set the amount of deviation to more than the deviation limit of +/-10%, you will see this message:

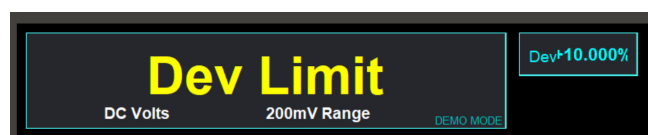

As an alternative to using the plus and minus deviation buttons, you may enter a deviation value directly using the keyboard. To do this, first click on the deviation value. An entry box will appear:



Enter a value between -9.999 and +9.999 using your keyboard's numeric keys and then press the **Enter** key. The new deviation will be set.

### 7.2.6. Monitoring the Internal Temperature

To operate within specification, the xx51 must be located in a stable environment at 22°C +/- 3degC. It is also important that the internal temperature has stabilised. This is constantly displayed on the screen below the numeric keypad:



In addition to the temperature, the rate of change in temperature is shown in °C/min (averaged over the last ten minutes). Accurate calibrations should not be attempted if the rate of change displayed is greater than 0.02°C/min.

Note, the rate of change in temperature is only shown after the xx51 control program has been running for more than ten minutes.

#### Exiting the DCV screen

Press the **Menu** button to return to the main FUNCTION selection screen. Note, the output will automatically be zeroed when **Menu** is pressed.

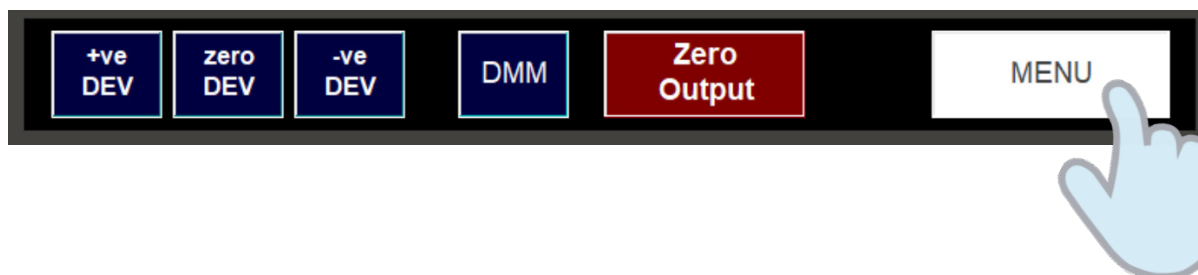

## 7.3. DC Current

DC I

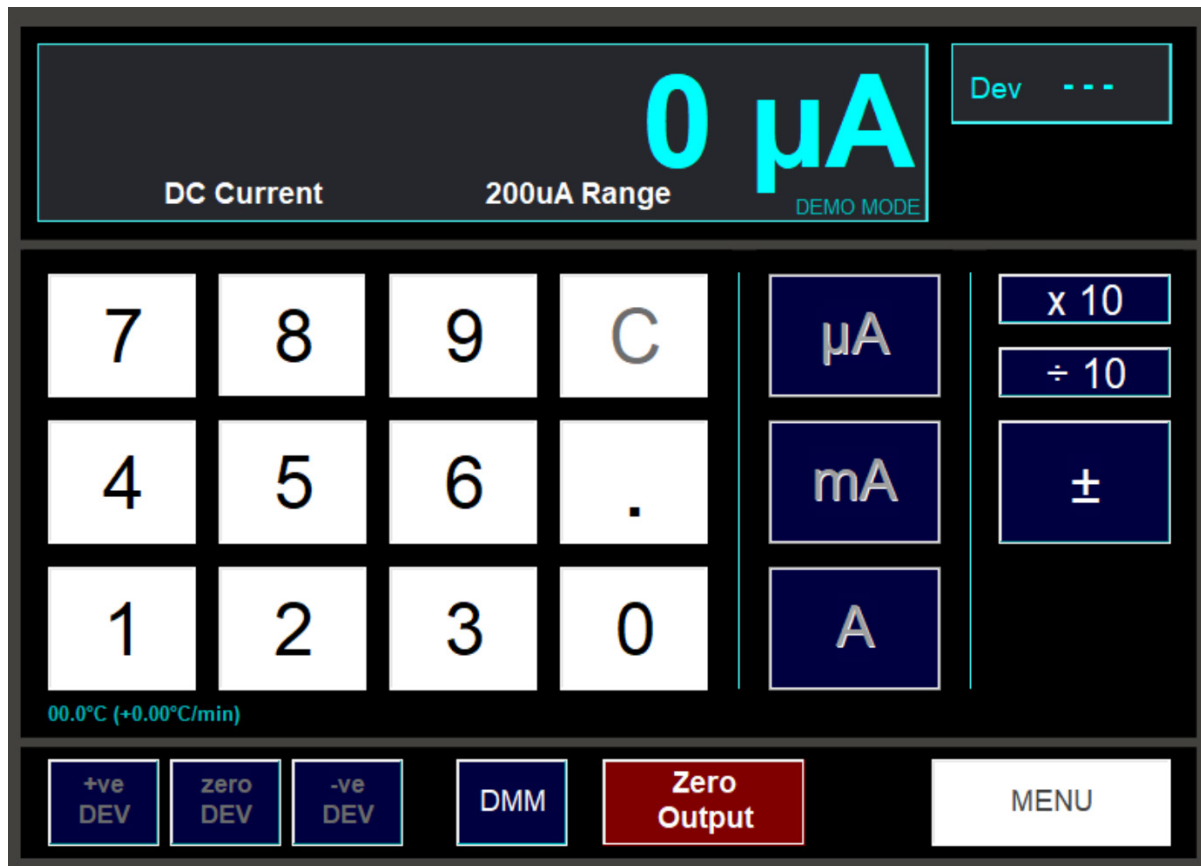

The layout and usage of this screen is almost identical to the screen used for setting DC V. For common controls such as setting the output and using deviation, please refer to the DC V section. Described in this section are features specific to the DC I control screen.

### 7.3.1. Current Output Terminals

For currents above 220mA, output will always be from the Hi Current terminals. Output levels below this will be from the Main or Aux terminals (as specified on the Options screen – see later section). When the output terminals change, a window will appear to inform you:

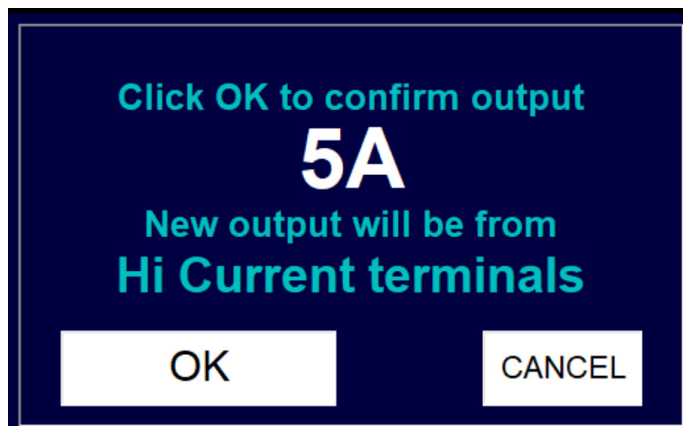

In addition, while the window is being displayed, the LED beside the output terminal in use will flash to indicate that output is about to be connected to that terminal. It is safe to connect to the new terminal at this stage.

7.3.2. DC Current Connection Diagrams

DC I

**DC Current (DC A) < 200 mA**

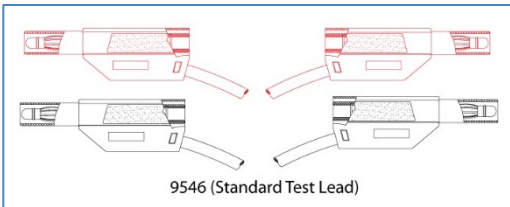
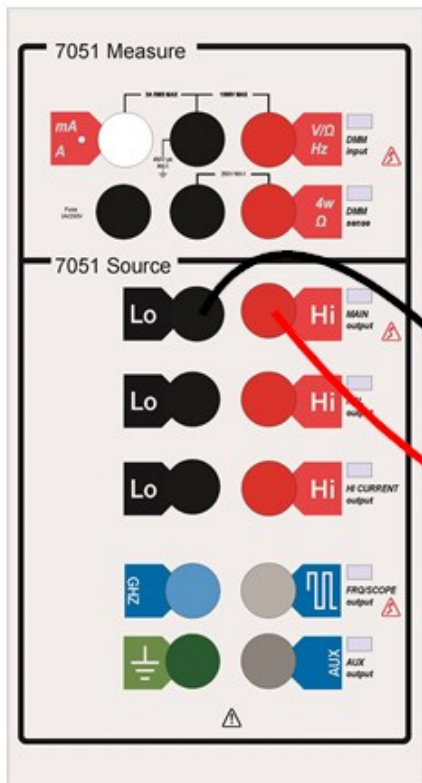

**DC Current (DC A) > 200 mA**

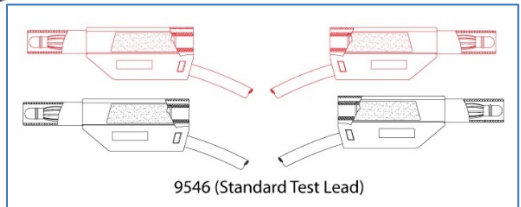
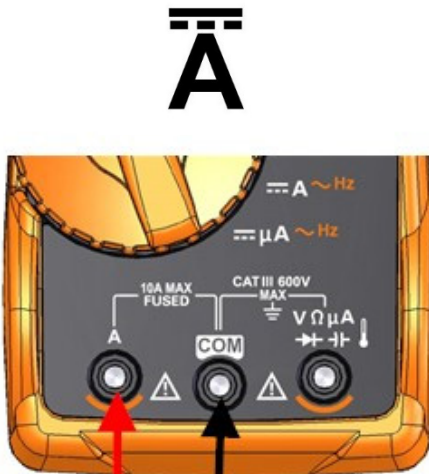
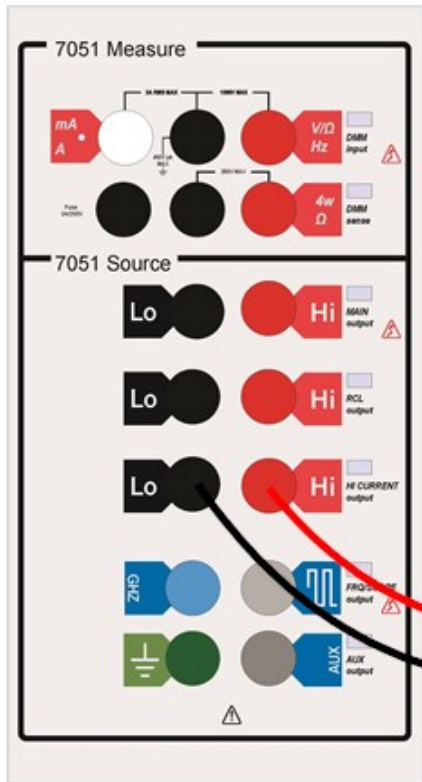



### 7.3.3. Output Error

DC I

Should the load attached to the output terminals be too high in value (e.g. an open circuit), and the set output is non-zero, a warning will be displayed at the base of the readout window. This condition occurs when the xx51 is unable to provide sufficient compliance voltage to the load.



The “Output Error!” message will flash, alternating with the function and range displays.

While the output error condition exists, a drive voltage will remain on the terminals. As soon as an acceptable value of load is connected, the warning message will disappear and the output current will return to the displayed value.

### 7.3.4. High Current Interlock and Ramping

In the same way as for high volts, high current outputs (2A and above) feature a safety interlock system. High current outputs will prompt a window to appear requiring confirmation from the user.

If the new current output selected is 2A (or more) greater than the present output, current ramping will occur. During this process, the following window will appear:



The **Stop Output** button can be pressed during ramp up in order to zero the output if required.

If the new current output is 2A (or more) less than the present output, then ramping down of the current will occur. The following window will appear during that process:

## 7.4. AC Voltage

AC V

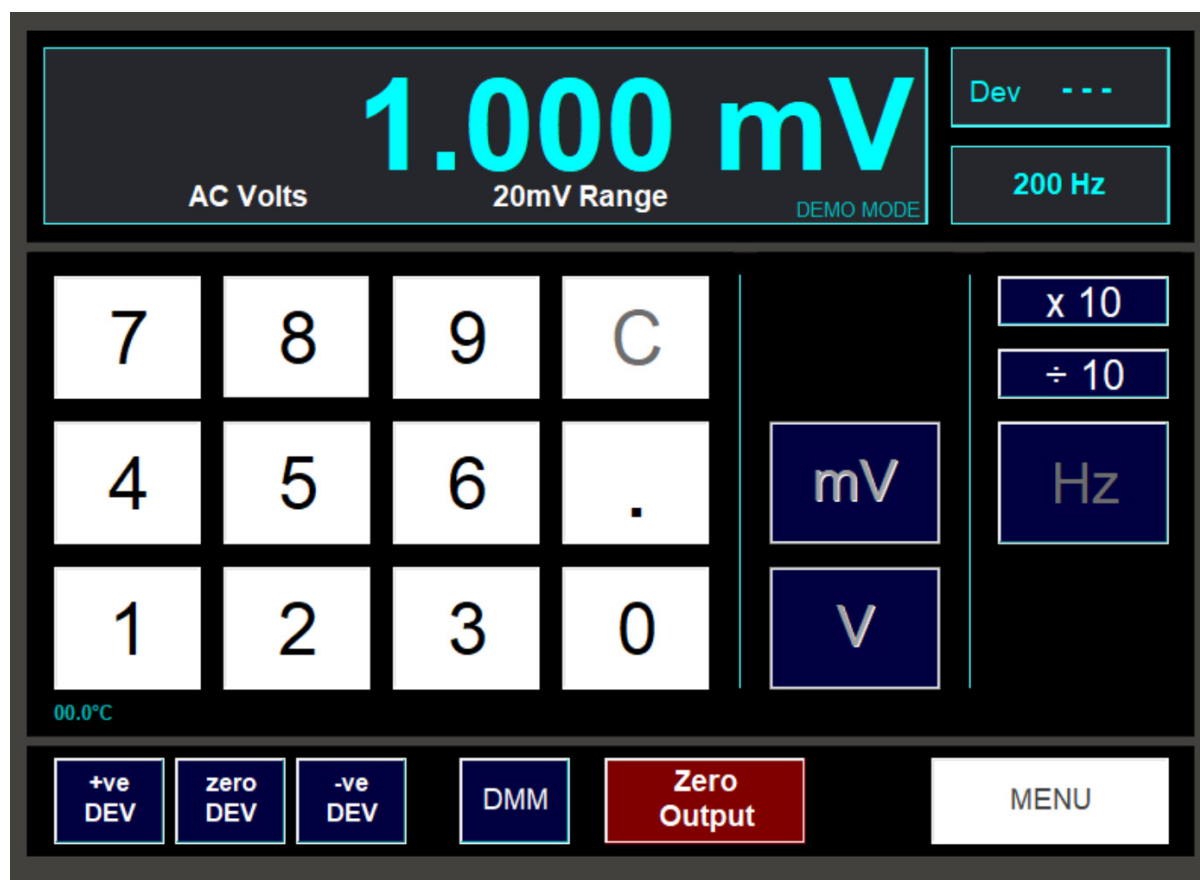

The selection process for AC voltage is identical to DC voltage with an additional option to set the frequency by using the **Hz** button (which replaces the +/- button on the DCV screen). After the output value has been set, the value of the required frequency is input using the digit buttons followed by the **Hz** button. The frequency is shown in a window in the top right of the screen.

### 7.4.1. Frequency Limits

Please note that the allowable frequencies are 10Hz - 20kHz for the 200mV, 2V and 20V ranges, and 40Hz - 1kHz for the 200V and 1 kV ranges.

### 7.4.2. HV Interlock and Ramping

As with DCV, a safety interlock feature is incorporated to ensure that user must undertake an additional confirmation when voltages about 40V are selected. Ramping of voltage outputs also occurs with ACV if the new voltage selected is 100V (or more) different from the present voltage. For more details on interlock or ramping, see the information in the DCV section.

### 7.4.3. Low Output Range – 20mV

It should be noted that the xx51, as with other precision AC voltage sources is not able to output exactly zero. There is always a small residual voltage on the output terminals even when zero is selected. This is typically 0.6 to 0.9mV. The unit is calibrated to be correct at 2mV (10% of range full-scale) but should not be used for accurate calibration below this value. If lower values are required, it is recommended that an external resistive attenuator is used, taking account of the xx51's output resistance of 10ohms.

7.4.4. AC Voltage Connection Diagrams

AC V

AC Voltage (AC V)

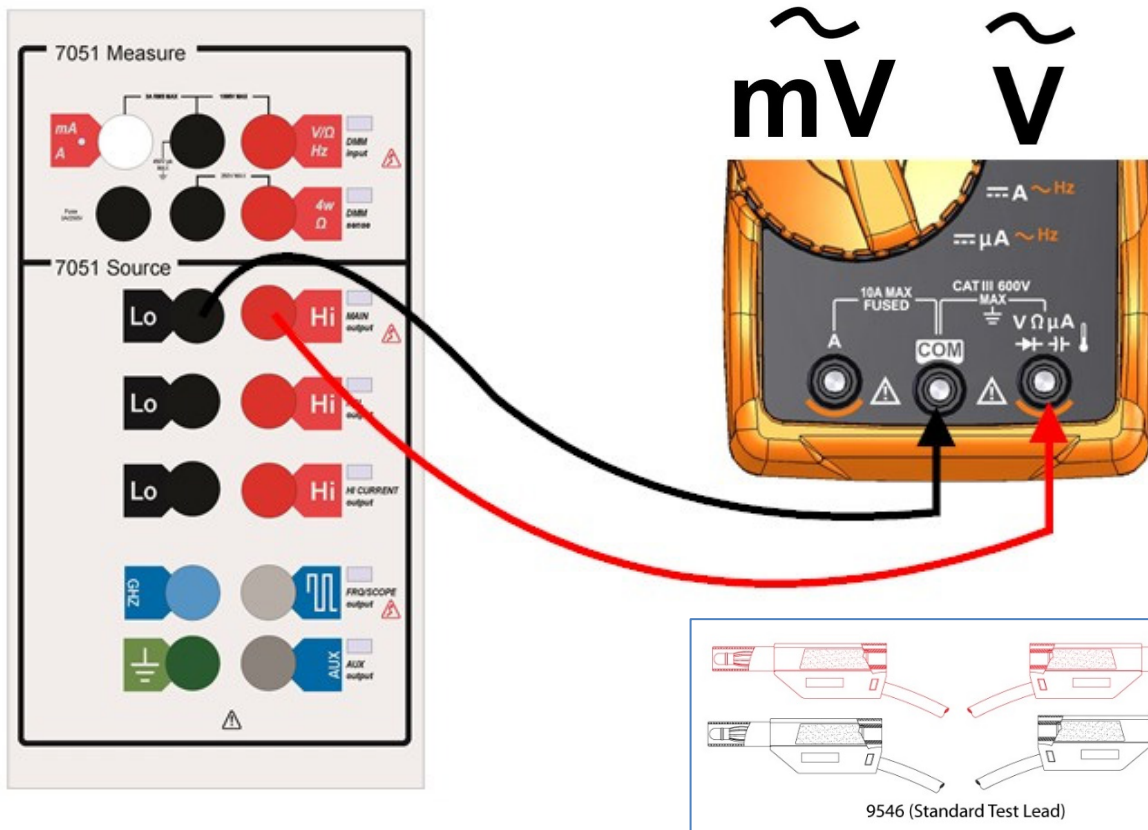

AC Voltage (AC V) > 20 kHz

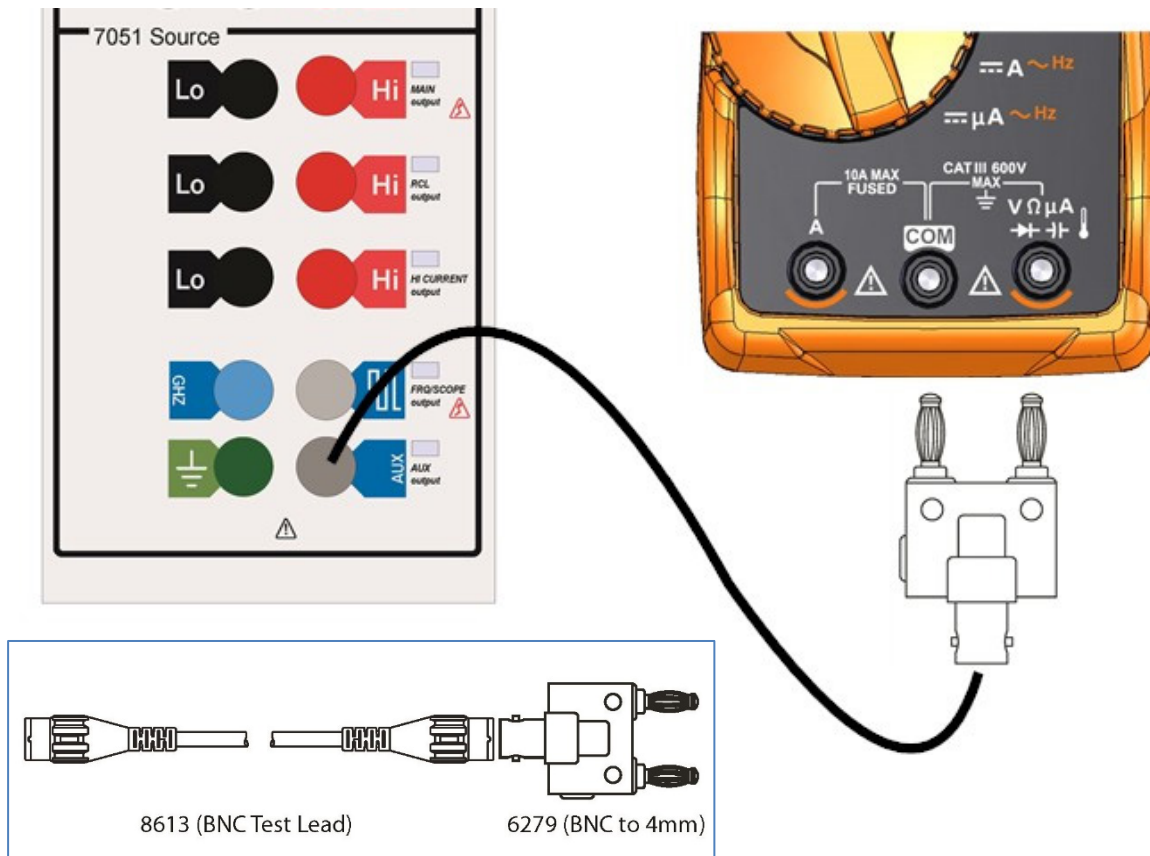

## 7.5. AC Current

AC I

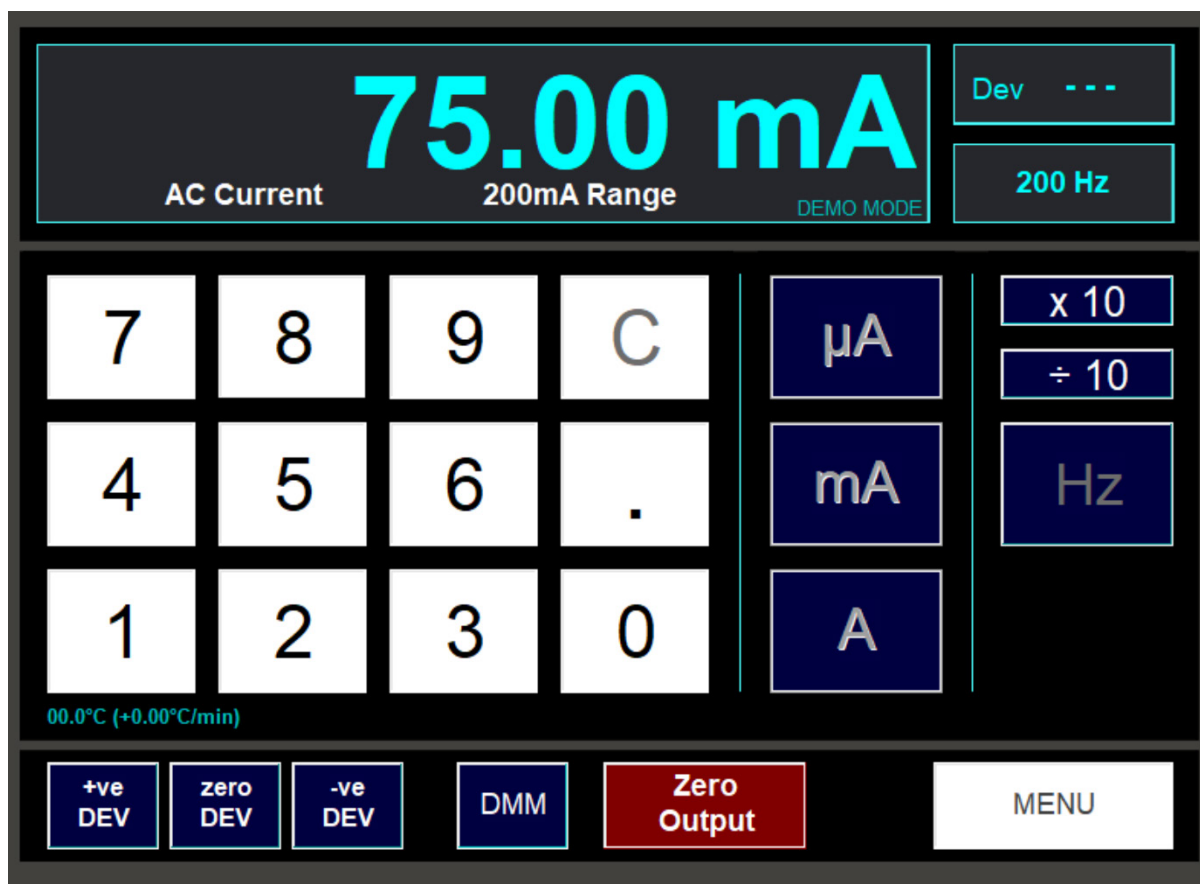

The operation of the ACI screen is the same as DCI. In addition, the frequency of the output may be set by entering a value using the numeric keypad and then pressing the **Hz** button. The present frequency is shown in the top-right corner of the screen.

### 7.5.1. AC Frequency Limits

Note, the AC frequency limits are:

10Hz – 1kHz	0 - 220mA
20Hz – 500Hz	Above 220mA

If the frequency entered is too high or too low for the present output, it will be changed to the nearest allowed frequency.

#### Lowest Output Range – 200uA

It should be noted that the xx51, as with other precision AC current sources is not able to output exactly zero. There is always a small residual current on the output terminals even when zero is selected. This is typically 6 to 9uA. The unit is calibrated to be correct at 20uA (10% of range full-scale) but should not be used for accurate calibration below this value.

7.5.2. AC Current Connection Diagrams

AC I

**AC Current (AC A) < 200 mA**

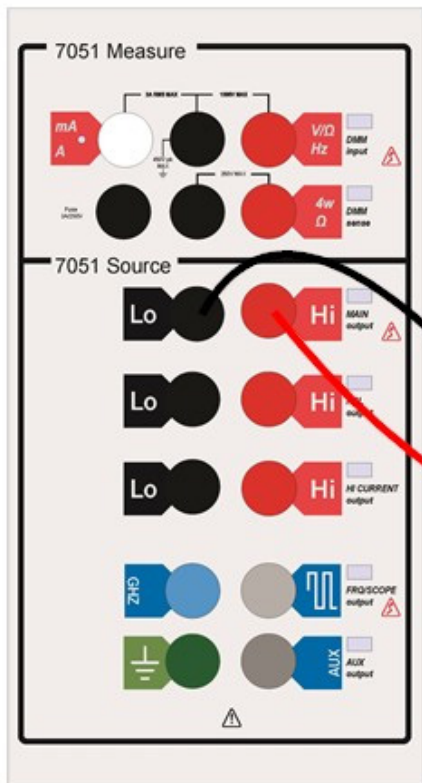

$\overline{\mu A}$     $\overline{mA}$

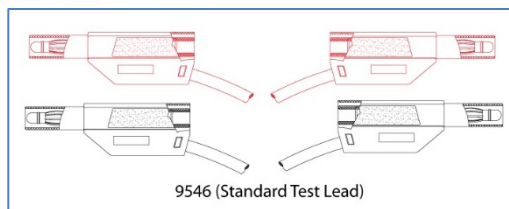
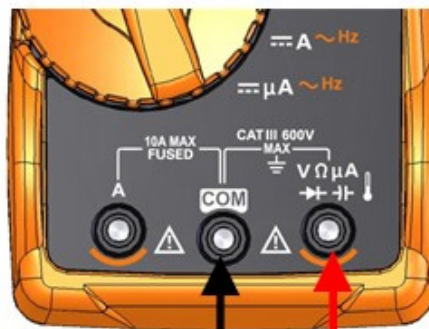

**AC Current (AC A) > 200 mA**

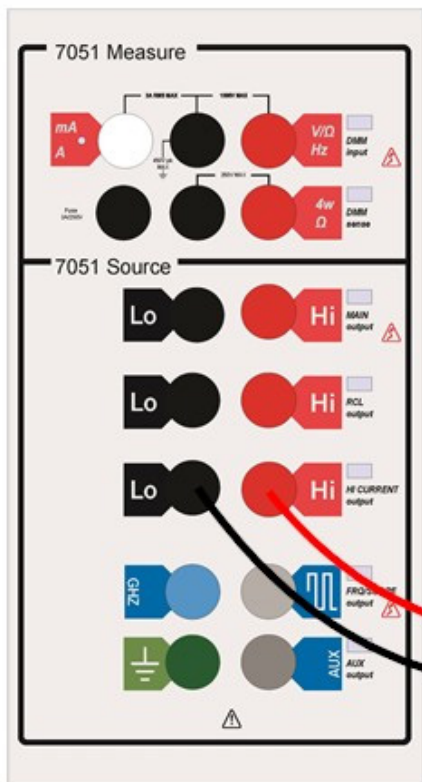

$\sim A$

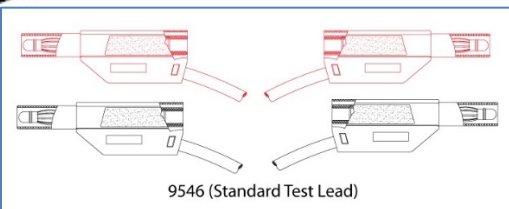

## 7.6. R-G-C-L Function Selection

R-G-C-L

### R-G-C-L:

- **R = Resistance**
- **G = Conductance**
- **C = Capacitance**
- **L = Inductance**

By pressing the R-G-C-L button on the main function selection screen, a new menu is displayed:

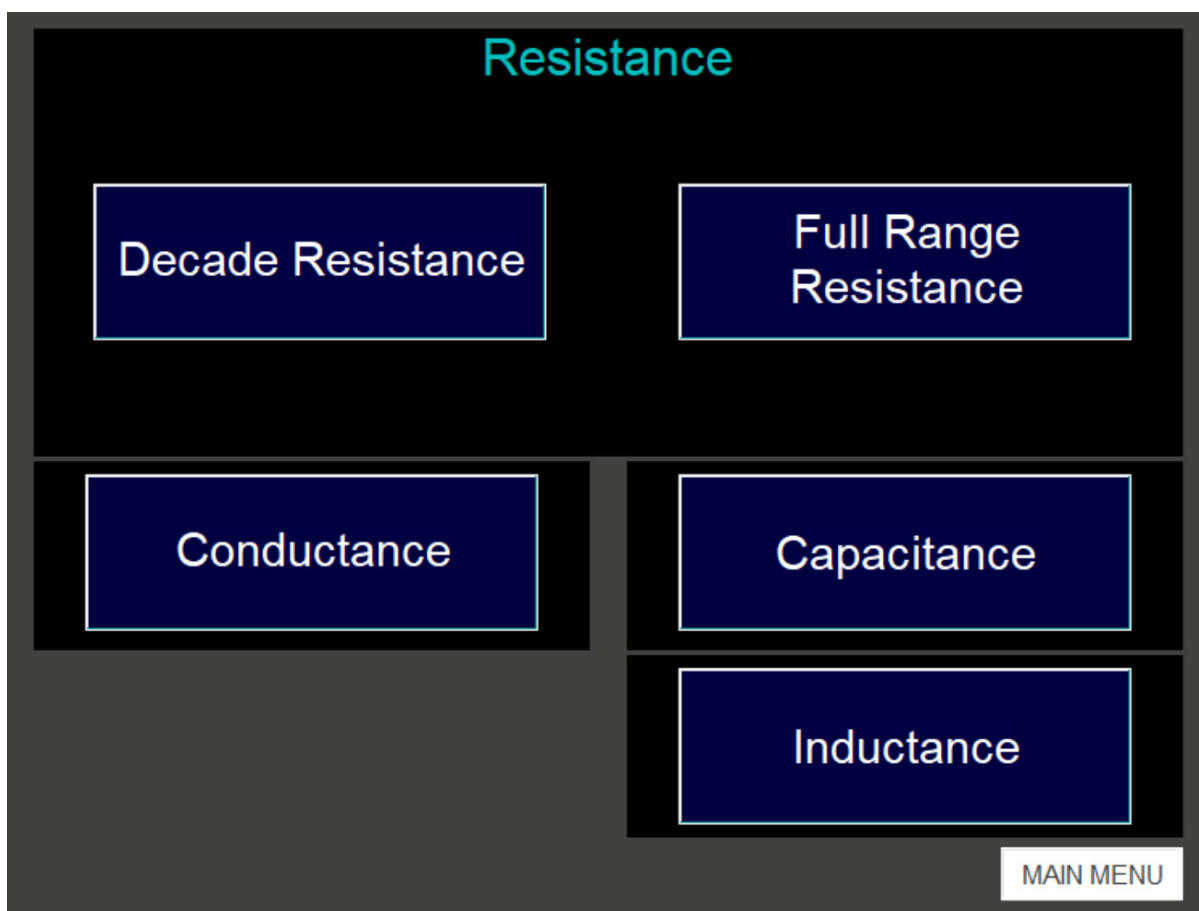

This R-G-C-L function selection screen allows selection of any of the resistance, conductance, capacitance and inductance functions.

The xx51Plus features both Decade Resistance and Full Range (variable) Resistance.

### 7.6.2. R-G-C-L Connection Diagram

R-G-C-L

Connection is via the RCL Output terminals for these functions:

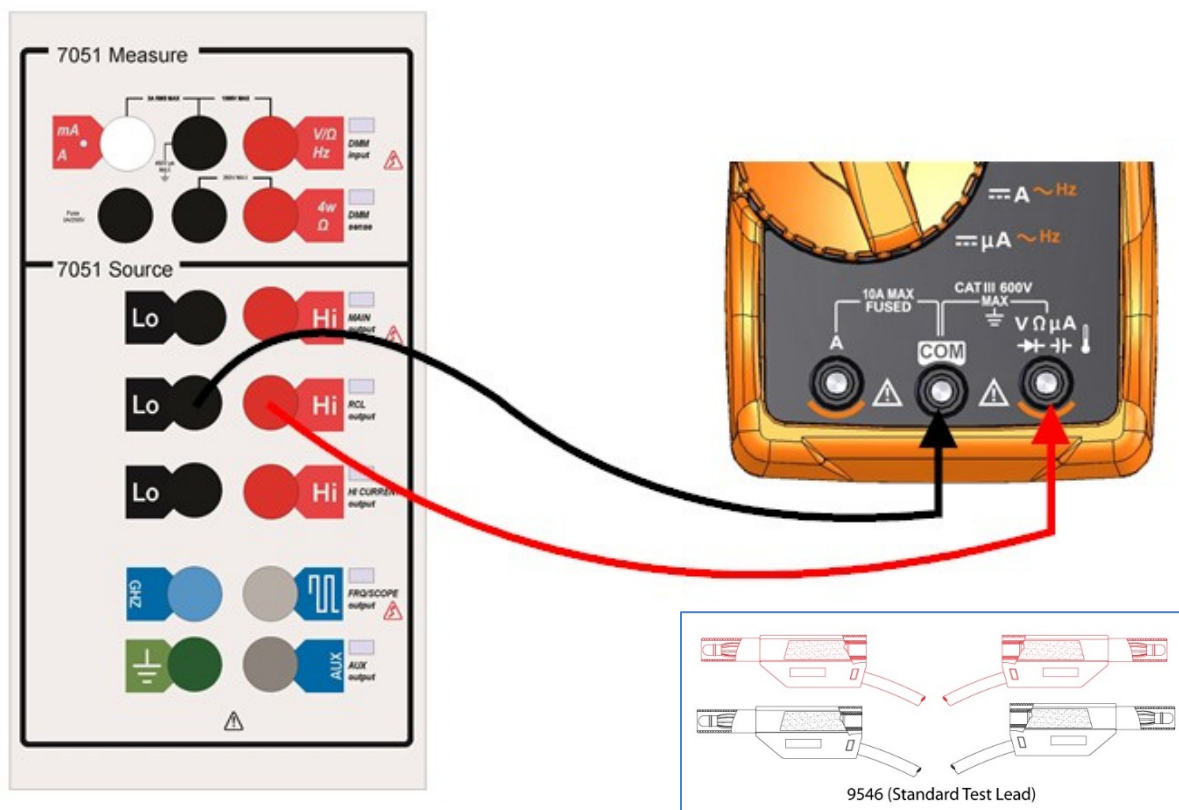
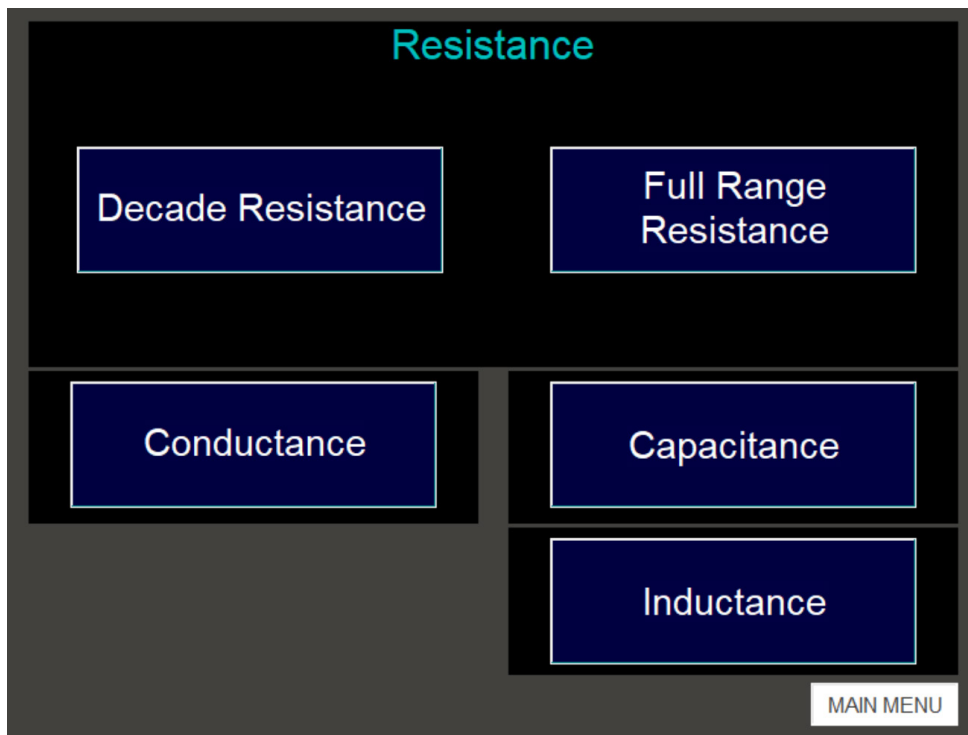





### 7.6.4. Full Range Resistance

Full Range  
Resistance

Any resistance output between 1 ohm and 120M ohms may be selected.

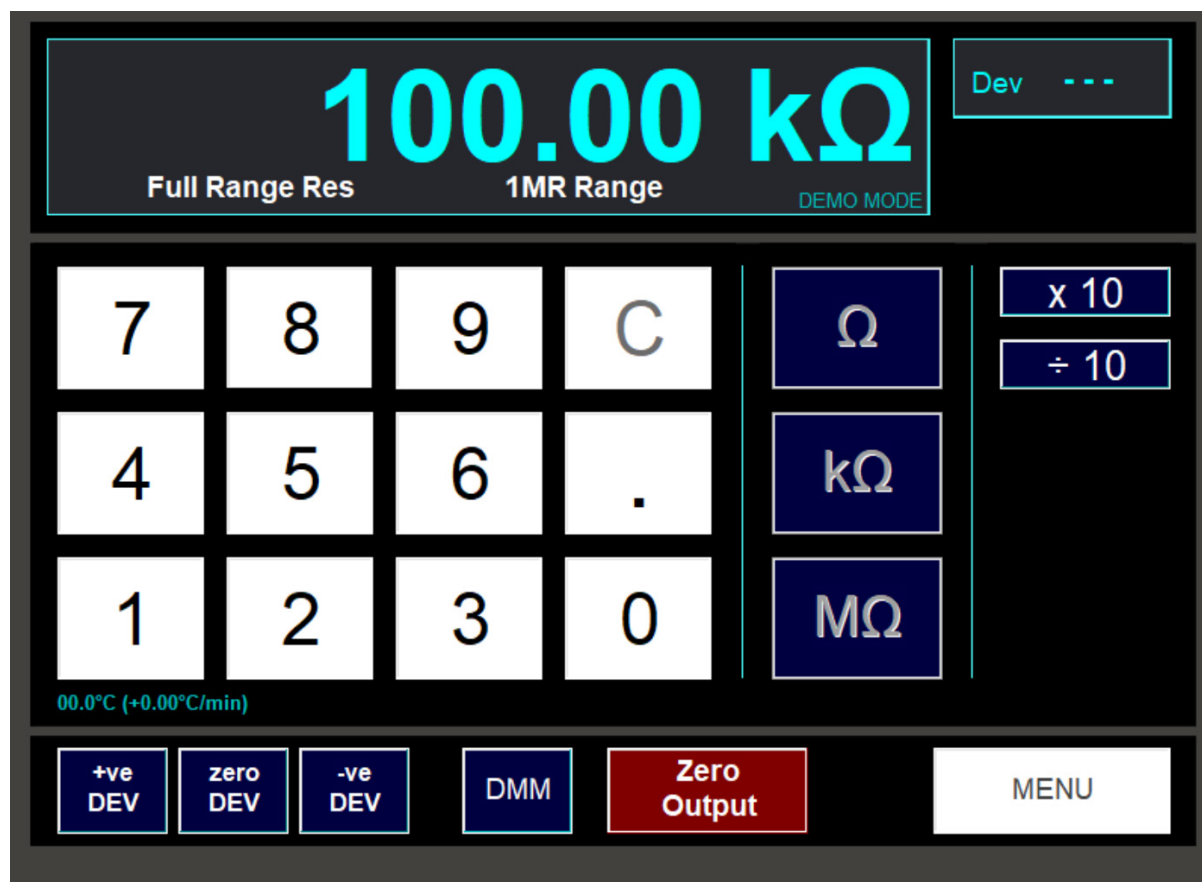

#### 7.6.4.1. Setting the Output Value

Enter the value required using the numeric keypad. Then press one of the unit buttons to set the output.

Use the **x10** and **/10** buttons to multiply or divide the present output by ten.  
Use the **Dev** buttons to deviate the output as required in the usual way.

Ensure screened leads are used for values above 100Kohms to avoid noise pickup.

#### 7.6.4.2. Exiting the Full Range Resistance Screen

Press the **Menu** button to return to the R-G-C-L function selection screen.

### 7.6.5. Conductance

Conductance

Conductance is available on the R-G-C-L function menu screen.



#### 7.6.5.1. Setting the Output Value

Press the output button required in the main area of the screen. The new output will be applied to the output terminals, and the readout at the top of the screen will display the new value.

#### 7.6.5.2. Exiting the Conductance Screen

Press the **Menu** button to return to the R-G-C-L function selection screen.

## 7.6.6. Capacitance

### Capacitance

Capacitance is selected on the R-G-C-L function menu screen.



### 7.6.6.1. Selecting an Output Value

Press the output button required in the main area of the screen.

The accuracy specification applies at 1kHz (100Hz for 100uF) and is series mode.

The user should be aware of the effects of stray capacitance in leads and connections. The effect of these should be accounted for, or balanced out, to obtain accurate calibrations, particularly for the 1nF value.

### 7.6.6.2. Exiting the Capacitance Screen

Press the **Menu** button to return to the R-G-C-L function selection screen.

### 7.6.7. Inductance

Inductance

Inductance is selected on the R-G-C-L function menu screen.

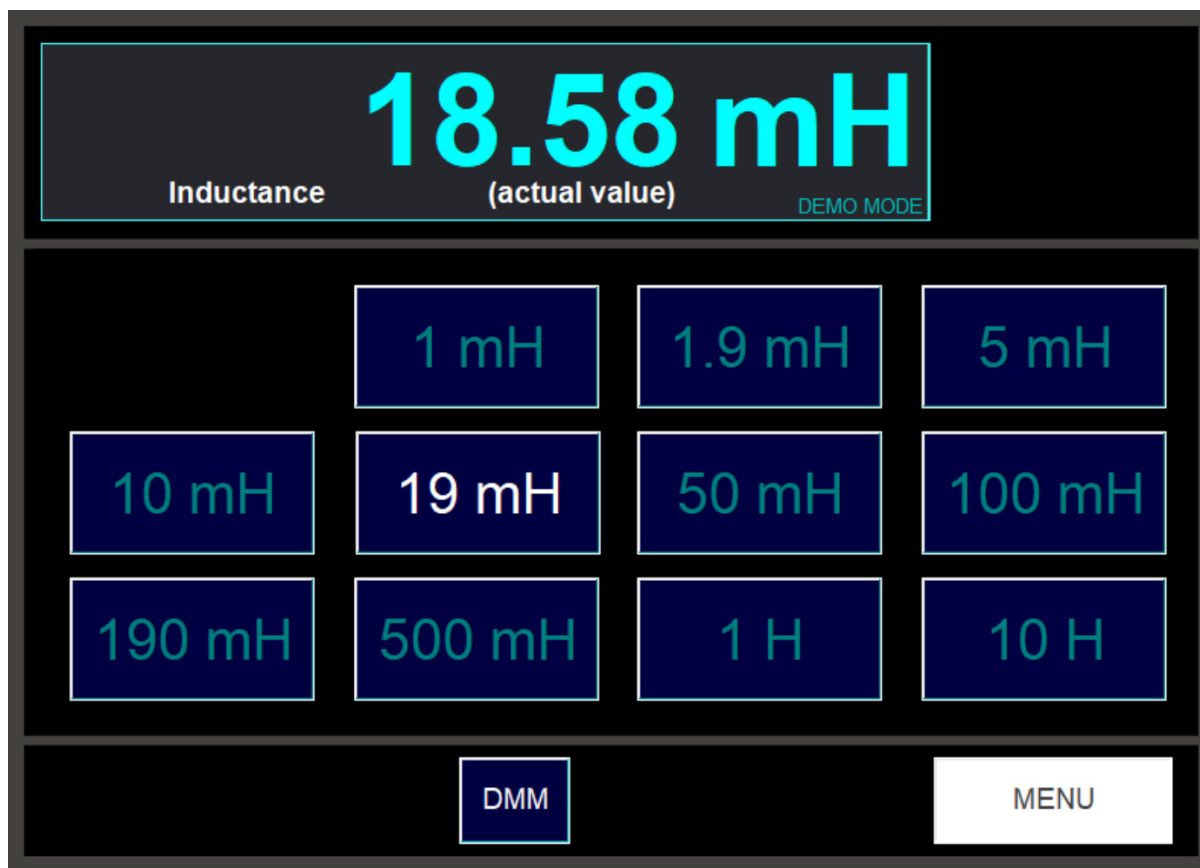

#### 7.6.7.1.1. Selecting an Output Value

Press the output button required in the main area of the screen. Eleven values of inductance are available, 1mH to 10H. The nominal values are shown on the buttons. The display above shows the value that was measured at the time of the last calibration.

The accuracy of the internal inductors will be within 1% of the nominal values. However, the 1 year specification will be within 0.1% of the value displayed (the value at the last calibration).

For example, in the screenshot above, the output selected was 19mH, but the actual output value is 18.58mH +/- 0.1%.

The user should be aware of the effects of stray inductance. These should be taken into account, or balanced out, to ensure accurate calibration using the lower values.

The accuracy specification applies at 1kHz (100Hz for 10H).

#### 7.6.7.2. Exiting the Inductance Screen

Press the **Menu** button to return to the R-G-C-L function selection screen.

## 7.8. Temperature Simulation Selection

Both thermocouple and PRT simulation is available.

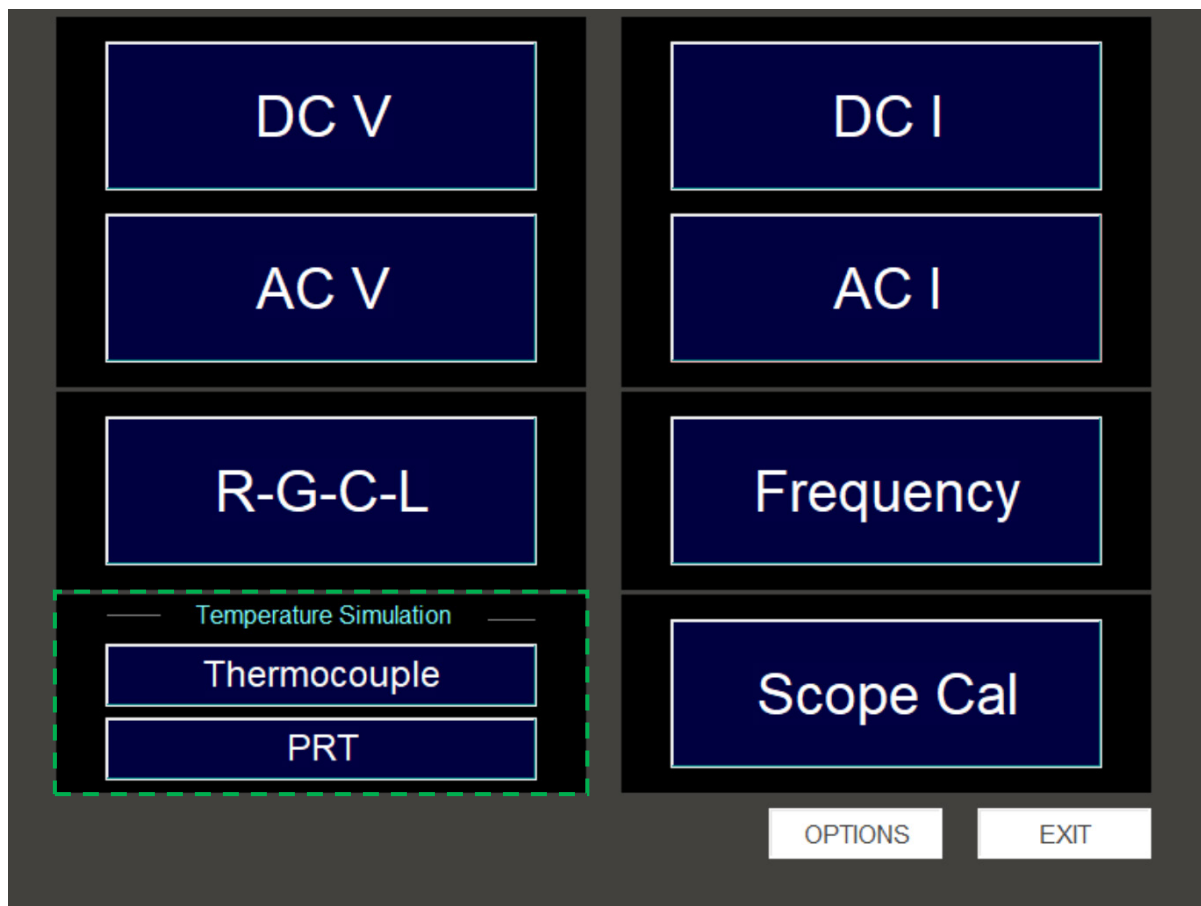

The thermocouple simulation is via the xx51's precision voltage source.

Accurate translation from temperature to voltage is via the ISO standard conversion tables for the thermocouple types specified and accuracy is as given in the extended specifications supplied with this manual.

### 7.8.1. PRT Simulation

PRT

Any temperature between -200°C and 850°C may be simulated.

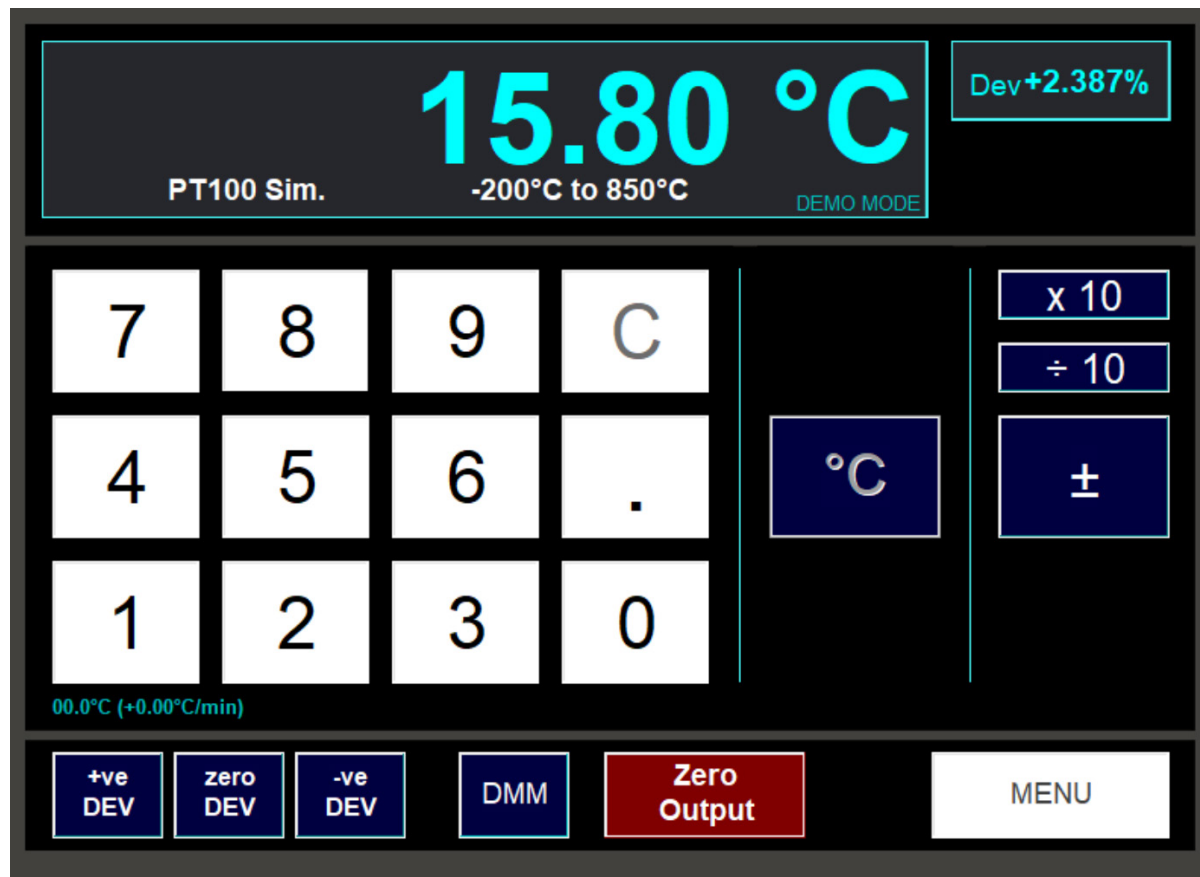

#### 7.8.1.1. Selecting the Output Value

Enter the output required using the numeric keypad and then press the °C button to set the output.

The +/- button can be used to toggle the simulated output temperature (if within the -200°C to 850°C range).

The x10 and /10 allow the simulated output temperature to be multiplied and divided by ten.

Pressing the **Zero Output** button sets the simulated output temperature to zero degC.

The **Dev** buttons can be used to deviate the output in the usual way.

#### 7.8.1.2. Exiting the PRT Simulation Screen

Pressing the Menu button returns to the Temperature function selection screen.

## 7.8.2. Thermocouple Simulation

Thermocouple

There are eight types of thermocouple that may be simulated, each selected from the Temperature function selection screen.

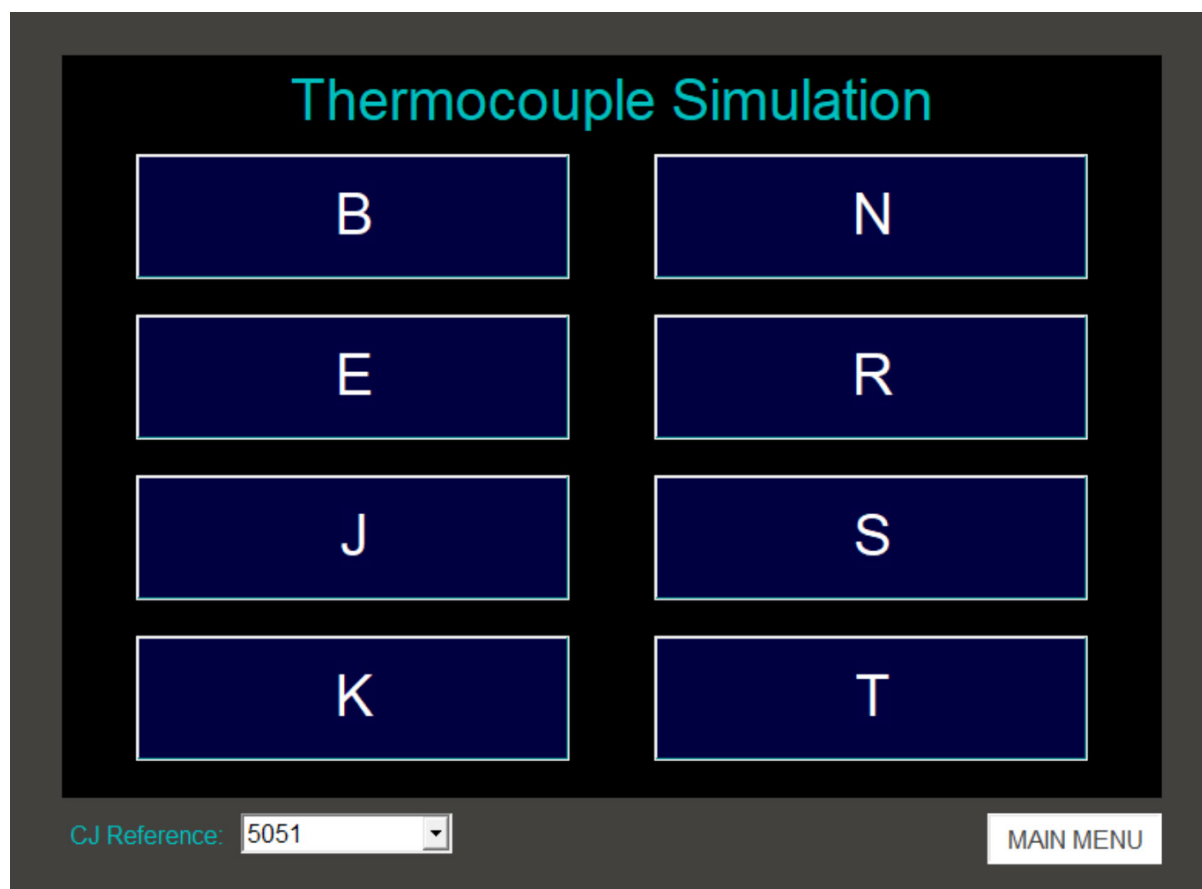

The range of temperatures that can be simulated depends on the type of thermocouple selected:

<b>B</b>	<b>0°C to 1820°C</b>
<b>E</b>	<b>-270°C to 1000°C</b>
<b>J</b>	<b>-210°C to 1200°C</b>
<b>K</b>	<b>-270°C to 1372°C</b>
<b>N</b>	<b>-270°C to 1300°C</b>
<b>R</b>	<b>-50°C to 1768°C</b>
<b>S</b>	<b>-50°C to 1768°C</b>
<b>T</b>	<b>-270°C to 400°C</b>

Thermocouple

The user should be aware of the errors that can occur due to thermal emfs and loading. For output equivalent to 22mV or less, the xx51's output resistance is 10 ohms.

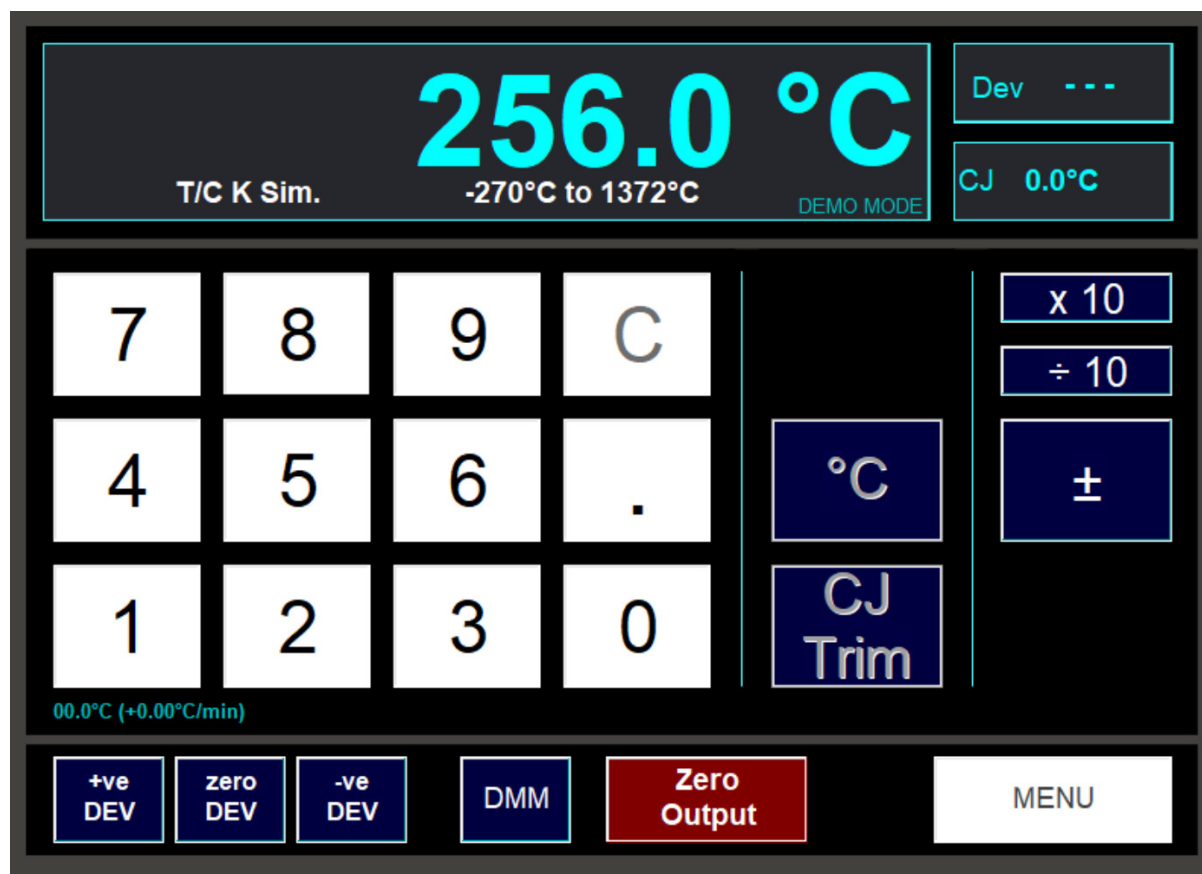

### 7.8.2.1. Selecting the Output Value

Enter the output required using the numeric keypad and then press the °C button to set the output.

The +/- button can be used to toggle the simulated output temperature (if within the -270°C to 1372°C range).

The x10 and /10 allow the simulated output temperature to be multiplied and divided by ten.

Pressing the **Zero Output** button sets the simulated output temperature to zero degC.

The **Dev** buttons can be used to deviate the output in the usual way.

#### CJ Trim

The 7051's internal cold junction reference value can be trimmed by this additional setting, to correct for any thermal drifts or inaccuracies due to the UUT's cold junction compensation.

In effect it is a zeroing mechanism that allows the accuracy of the UUT's cold junction compensation to be disregarded and calibration performed purely on the UUT's capability to measure the EMF voltages for the specified thermocouple type.

### 7.8.2.2. Exiting the Thermocouple Simulation Screen

Pressing the Menu button returns to the Temperature function selection screen.



## 7.9. Oscilloscope Calibration

Scope Cal

The xx51Plus is fitted as standard with an oscilloscope calibration feature.  
The following functions are provided:

- 1) **Amplitude** signals for calibrating the 'Y' channels
- 2) **Time Markers** for the Time Base calibration
- 3) **Frequency** for fixed outputs between 0.1Hz and 100MHz
- 4) **Bandwidth** calibration using fast rise
- 5) **Duty Cycle** for selection output between 0% and 100% at 3 selectable frequencies

If the Oscilloscope Calibration option is fitted, the menu function selection screen will include a Scope Cal button in the bottom right corner:

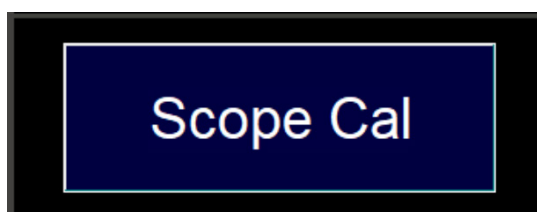

By pressing this button, the Oscilloscope Calibration function selection screen will be displayed:

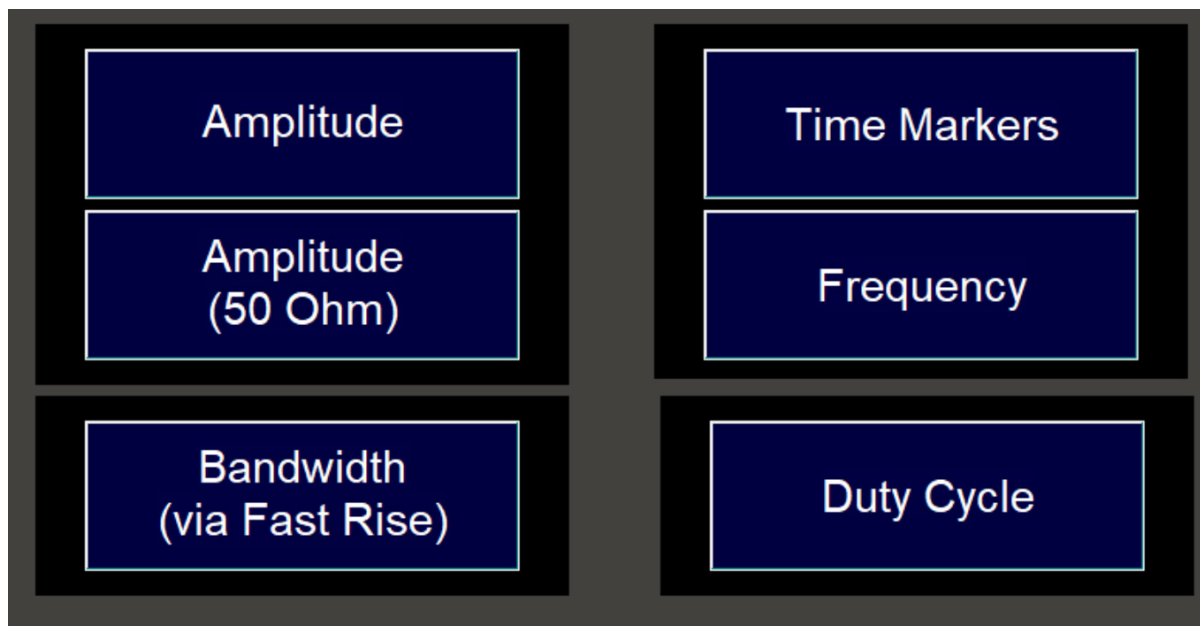

This selection screen allows access to each of the oscilloscope calibration functions.

The signals are output via the BNC connectors located on the front panel.

*Note that if the GHz Sweep option is fitted, the menu will display an extra button:*

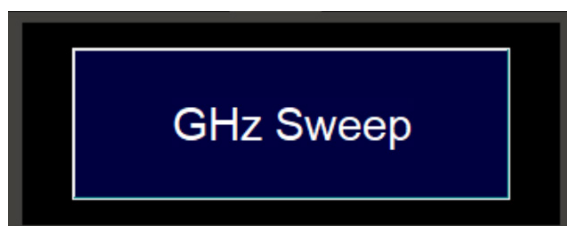

### 7.9.1. Amplitude

Amplitude

The Amplitude function is suitable for driving high impedance inputs. It allows outputs between 5mV and 220V. The output waveform may be either DC or a 1kHz square wave.

The screen for Amplitude is shown here:

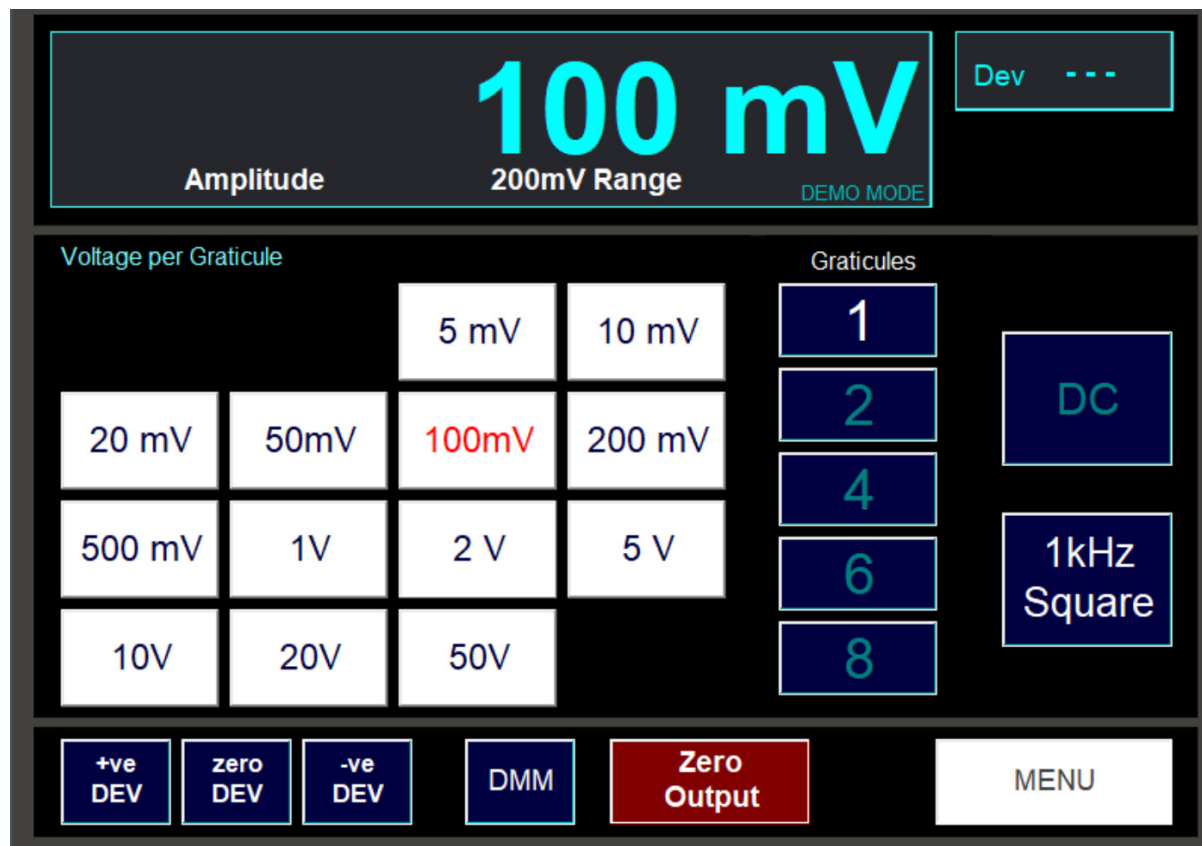

#### 7.9.1.1. Setting an Output

To set an output, decide the number of Y-axis graticules on the oscilloscope under test that you wish the output signal to occupy. Press the **Graticules** button required. Now set the voltage per graticule by pressing the required **Voltage per Graticule** button. Total output is:

$$\text{Output Voltage} = \text{Voltage per Graticule} \times \text{Graticules}$$

Note: Only buttons that will give an output in the allowed range 5mV to 200V will be displayed. For example, if the 1 graticule button is selected, then the 1mV and 2mV per graticule buttons will not be shown. Similarly, if the 50V per graticule button is selected, then the 6 and 8 graticules buttons will not be shown.

The output value may be deviated in the normal way using the **Dev +** and **Dev –** buttons.

#### 7.9.1.2. Setting the Output Waveform

Voltage outputs may either be a DC signal or a square wave of frequency 1kHz where the voltage selected is the pk-pk output. Press the **DC** and **1kHz** buttons to select the waveform.

#### 7.9.1.3. Exiting the Amplitude Screen

Pressing the **Menu** button will return to the Oscilloscope function selection screen.

## 7.9.2. Amplitude (50 ohm)

Amplitude  
(50 Ohm)

The Amplitude (50 ohm) function is suitable for driving a 50 ohm inputs. It allows outputs between 5mV and 2.2V. The output waveform may be either DC or a 1kHz square wave.

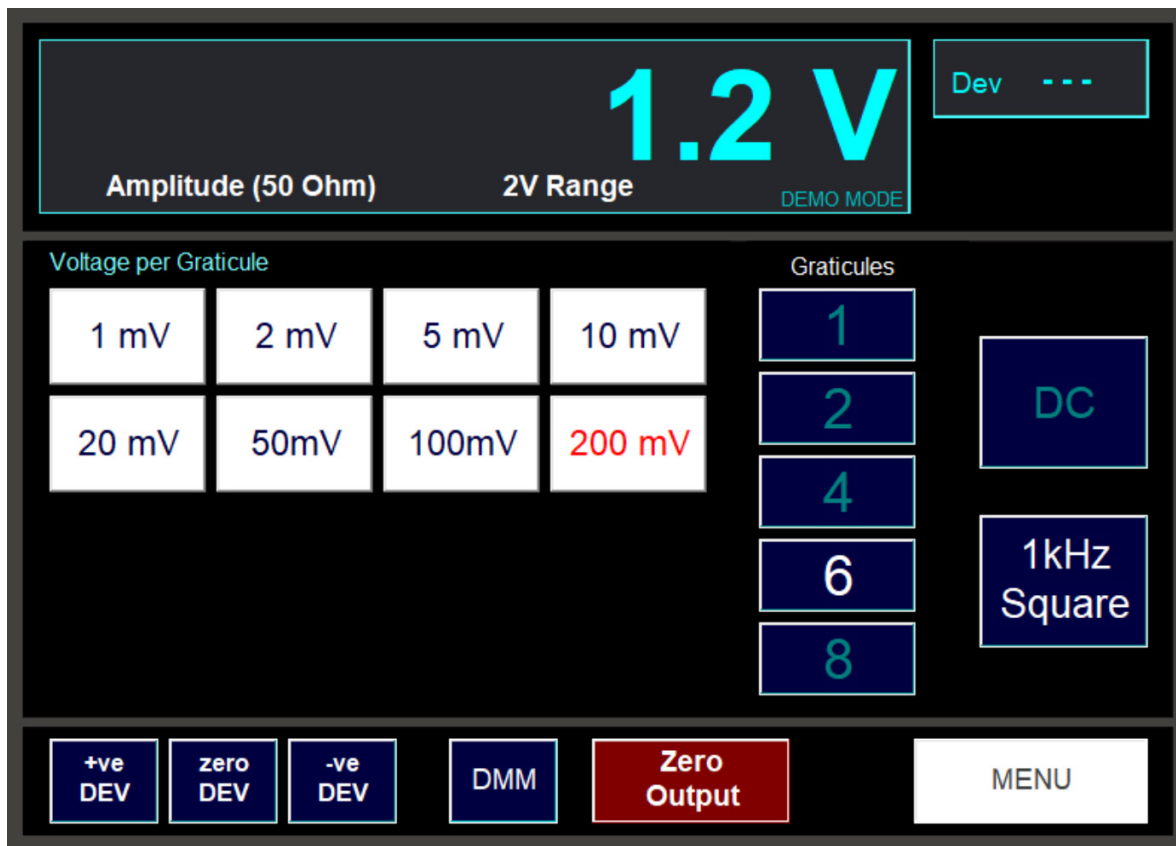

### 7.9.2.1. Setting the Output

To set an output, decide the number of Y-axis graticules on the oscilloscope under test that you wish the output signal to occupy. Press the **Graticules** button required. Now set the voltage per graticule by pressing the required **Voltage per Graticule** button. Total output is:

$$\text{Output Voltage} = \text{Voltage per Graticule} \times \text{Graticules}$$

Note: Only buttons that will give an output in the allowed range 5mV to 2V will be displayed. For example, if the 1 graticule button is selected, then the 1mV and 2mV per graticule buttons will not be shown. Similarly, if the 1V per graticule button is selected, then the 4, 6 and 8 graticules buttons will not be shown. The output value may be deviated in the normal way using the **Dev +** and **Dev -** buttons.

### 7.9.2.2. Setting the Output Waveform

Voltage outputs may either be a DC signal or a square wave of frequency 1kHz where the voltage selected is the pk-pk output. Press the **DC** and **1kHz** buttons to select the waveform.

#### \*\*\*\* IMPORTANT NOTE\*\*\*\*

The quality of the BNC bayonet connection can have a significant effect on the accuracy. They can have a connection resistance of 0.1 ohms or more. Therefore using a normal BNC lead to connect to the oscilloscope can add 0.2 ohms and this will reduce the signal appearing at the scopes input by 0.4%. For accurate 50 ohm calibrations allowance for this error must be made. However, the connection resistance is not stable and can vary as the connector is moved. For stable connections other screw type connectors are recommended. However, this type of connector is not very common on oscilloscopes.

### 7.9.2.3. Exiting the Amplitude (50 ohm) Screen

Pressing the **Menu** button will return to the Oscilloscope function selection screen.

### 7.9.3. Time Markers / Period

#### Time Markers

The time marker function allows output signals of fixed periods between 10ns and 10s.



#### 7.9.3.1. Setting the Output

The available time marker outputs are split into 3 ranges:

- 10ns to 5μs
- 10μs to 5ms
- 10ms to 10s

To set an output, first select the range containing the required period from the 3 range buttons. Then press the time marker button required to set the output.

#### 7.9.3.2. Output Levels

It should be noted that 10μs and above is 2V pk-pk square wave. 5μs and below is 1V pk-pk. Below 50ns, the rise time of the edges is apparent, and at 10ns the output is approximately sinusoidal, but still 1V pk-pk.

#### 7.9.3.3. Exiting the Time Marker Screen

Press the **Menu** button to return to the Scope Cal function selection screen.

## 7.9.4. Frequency

Frequency

This function allows selection of fixed frequency outputs between 0.1Hz and 100MHz.

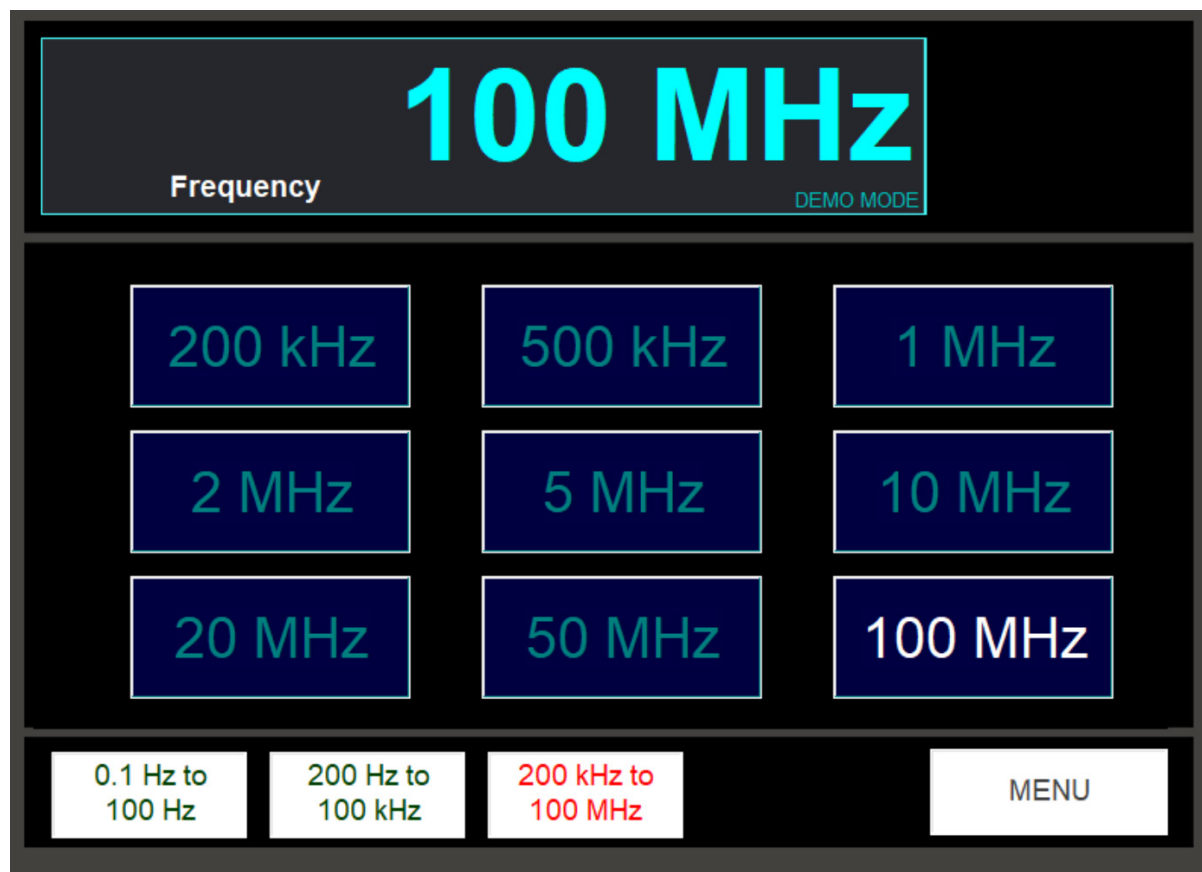

### 7.9.4.1. Setting the Output

Because of the large number of spot frequencies available, they are split into 3 ranges for display purposes:

0.1Hz to 100Hz

200Hz to 100kHz

200kHz to 100MHz

When setting a frequency output, first select the frequency range. The frequency buttons in the main area of the screen will change to display the values within the range. Press the frequency button required. This frequency signal will appear on the FREQ/SCOPE BNC connector on the front panel. The readout at the top of the screen displays the frequency.

### 7.9.4.2. Output Levels

It should be noted that 100kHz frequency and below is 2V pk-pk square wave, and 200kHz and above is 1V pk-pk. Above 20MHz, the rise time of the edges is apparent, and at 100MHz the output is approximately sinusoidal, but still 1V pk-pk.

### 7.9.4.3. Exiting the Frequency Screen

Press the **Menu** screen to return to the Scope Cal function selection screen.

### 7.9.5. Duty Cycle

## Duty Cycle

This function allows selection of duty cycle output between 0% and 100% at 3 selectable frequencies.

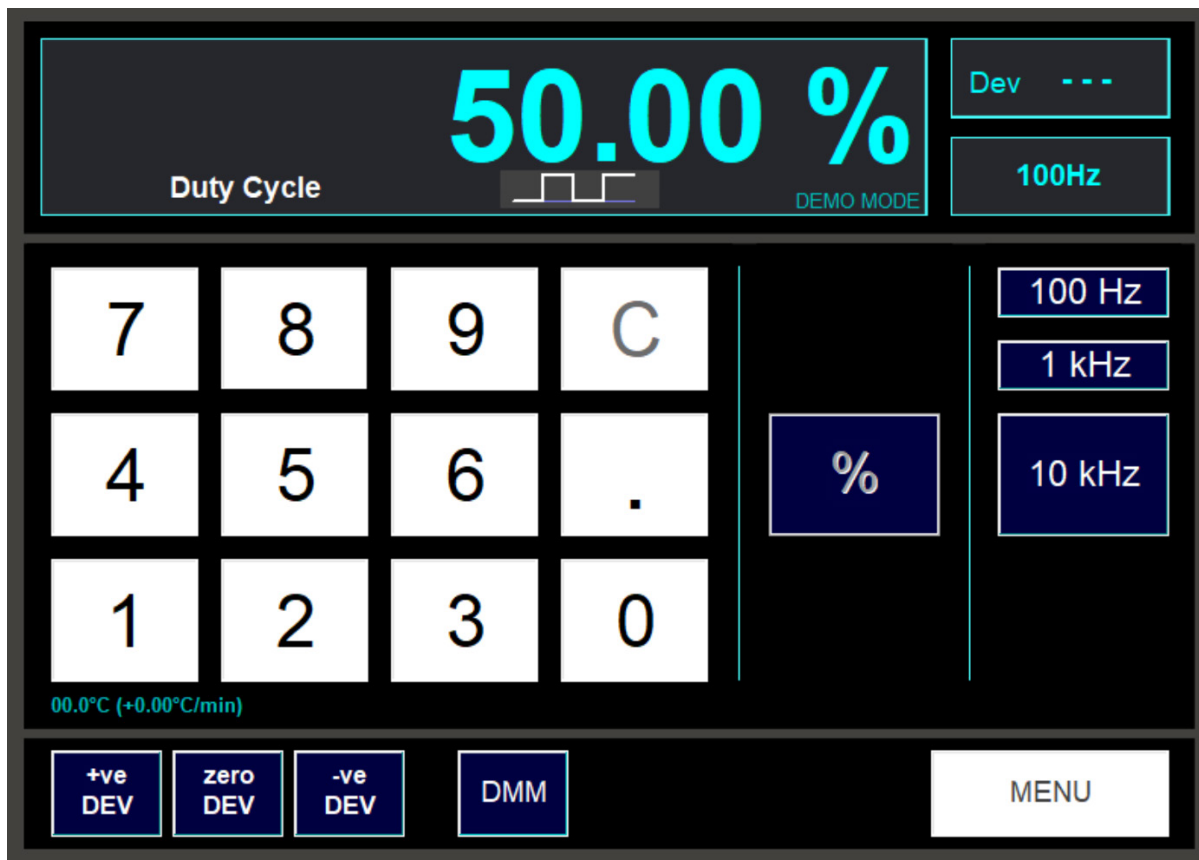

#### 7.9.5.1. Setting the Output

Enter the duty cycle required as percentage using the digit buttons, then press the % button to set the output. The readout at the top of the screen will display the duty cycle set. A small graphic below the digital readout provides a guideline to the appearance of the waveform.

#### 7.9.5.2. Selecting the Output Frequency

To select the output frequency, click one of the 3 frequency buttons on the right-hand side of the screen. The present frequency is shown in a small box in the right corner of the screen.

At each frequency the setting resolution of the duty cycle varies:

Frequency	Duty Cycle Resolution
100Hz	0.01%
1kHz	0.1%
10kHz	1%

The resolution of the selected frequency is indicated by the number of digits after the decimal place in the readout at the top of the screen.

#### 7.9.5.3. Deviating the Output

The duty cycle may be varied using the **Dev** buttons in the same way as for DCV and other functions. For more information see the DCV section.

#### 7.9.5.4. Exiting the Duty Cycle Screen

Pressing the Menu button will return to the Scope Cal function selection screen.

### 7.9.6. Bandwidth (via fast rise)

Bandwidth  
(via fast rise)

The Bandwidth function provides a means for calculating the approximate bandwidth of an oscilloscope. Selecting this function provides the fast rise-time signal needed for the determination of a scope's rise time.

**100 MHz**

Bandwidth (via Fast Rise) DEMO MODE

**Step 1: Rise Time Measurement**  
Measure the rise time (ns) of the waveform between 10% and 90% amplitude

100%  
90%  
10%  
0%

t = measured rise time (ns)

**Step 2: Bandwidth Calculation**  
Enter the measured rise time here to calculate the bandwidth

Measured rise time:  ns

**Calculate**

*The rise time of the 5051 is taken into account in the above calculation*

DMM MENU

The bandwidth is calculated by first measuring the scope's displayed rise time using the very fast rising edge of the xx51's fast-rise signal. The rise time value is then entered into the control application and the bandwidth is calculated using a mathematical formula. The result is shown in the readout at the top of the screen.

It is very important with all scopes to use a 50 ohm terminated input. Some scopes, such as the LeCroy and most of the Tektronix range have the ability to allow the user to switch in an internal 50 ohm termination. If this is not available, an external 50 ohm through termination - available from Time Electronics or main line electronics component distributors.

Set the "flat" portions of the waveform on 0% and 100% and measure the 10% to 90% rise time. The rise time (in nanosec) should be entered into the relevant box on the PC window. Pressing the **Calculate** button or hitting the Enter key will show the approximate bandwidth in the main display window. Note: The bandwidth calculation automatically compensates for the xx51's signal output rise time.

Bandwidth  
(via fast rise)

Shown below is an example of bandwidth determination of a TEK 3032 oscilloscope using the xx51's fast signal.

The measured rise time is about 1ns. If 1ns is entered into the xx51's bandwidth screen, a bandwidth of 350 MHz is shown, which is approximately correct for this scope.

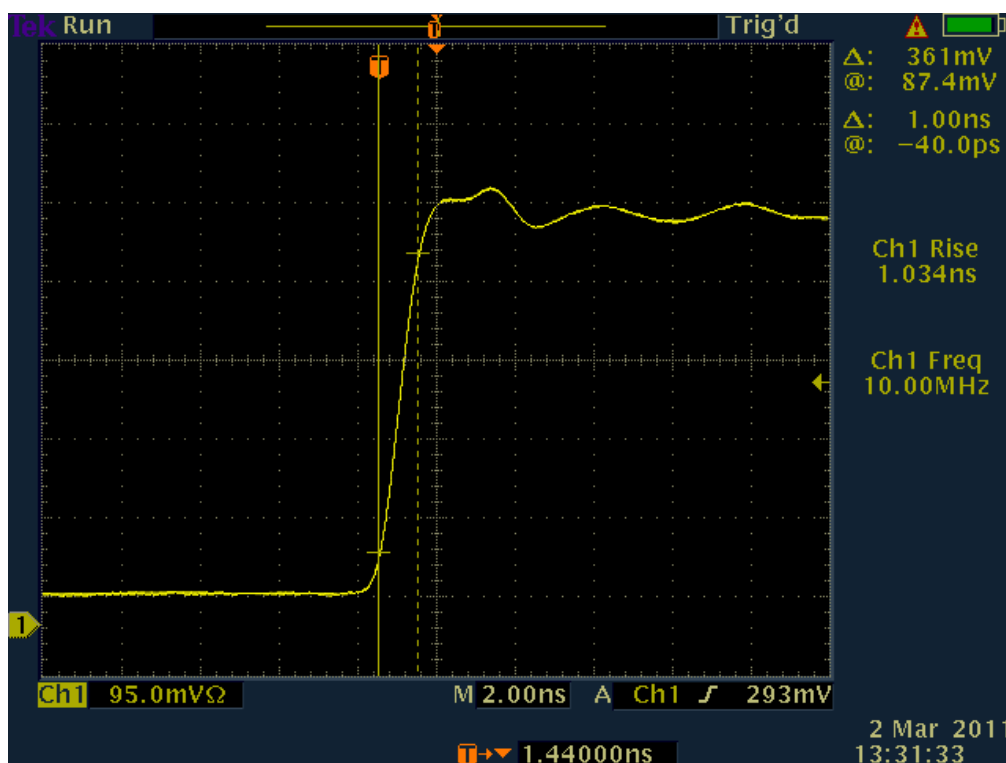

#### 7.9.6.1. Exiting the Bandwidth Screen

Press the **Menu** button to return to the Scope Cal function selection screen.



### 7.9.7. GHz Sweep

### GHz Sweep

The GHz output is 10MHz to 2.2GHz – 1V PK to PK

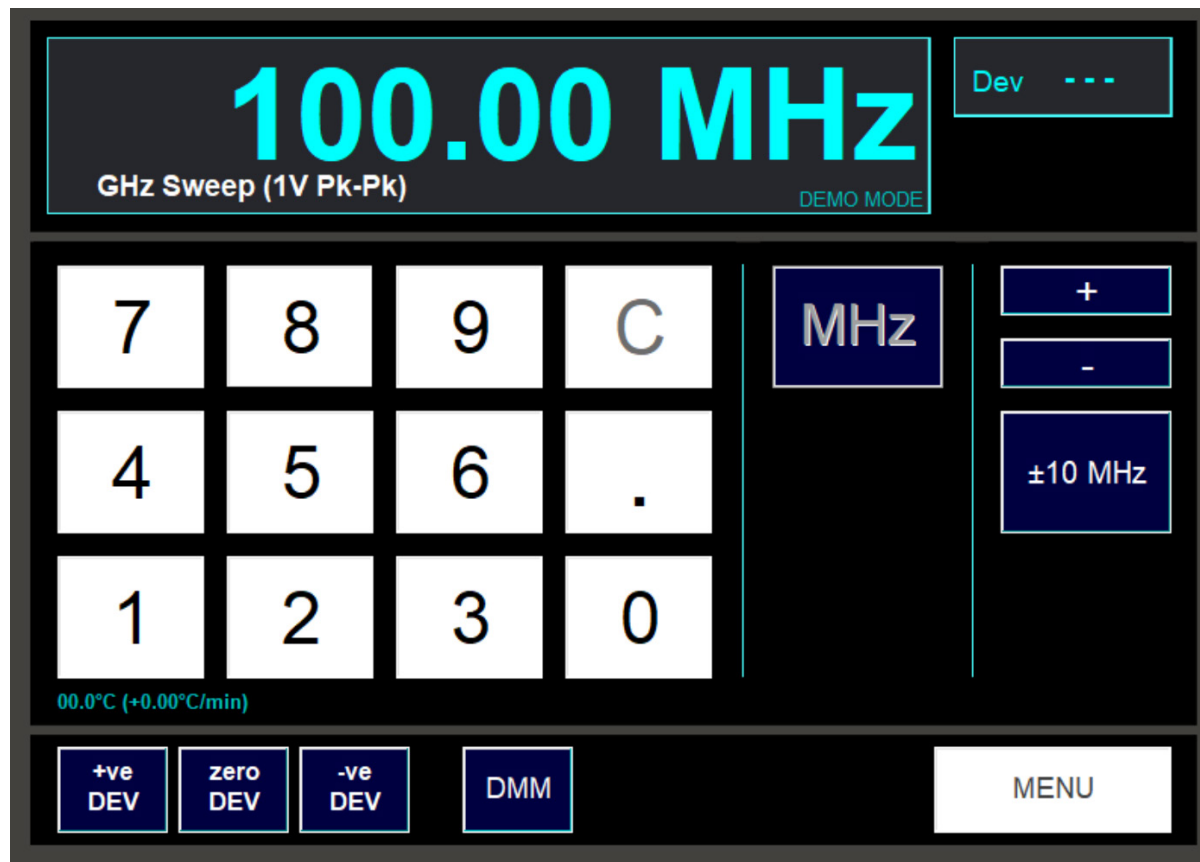

#### 7.9.7.1. Setting the Output

A conventional numeric keypad is used for setting the frequency. Enter the value required using the digit buttons. During entry, use the **C** button to delete the last digit entered, or hold down the **C** button for a second to delete all the entered digits.

Finally press the **MHz** button. The selected output frequency will now be present on the output terminals. The signal will output on the 'N-Type' connector on the front panel.

The readout at the top of the screen displays the frequency. The amplitude is set at 1V PK to PK.

#### 7.9.7.2. Frequency sweep

This is controlled by three sets of buttons.

The increment/decrement amount is selected by pressing the “+/- 1, 10, 100MHz” button.

The frequency can then be 'swept' +ve or –ve by pressing the “+” or “–” buttons.

#### 7.9.7.3. Exiting the Frequency Screen

Press the Menu screen to return to the Frequency function selection screen.

## 7.10. System Information

Pressing the **options** button will display this screen:

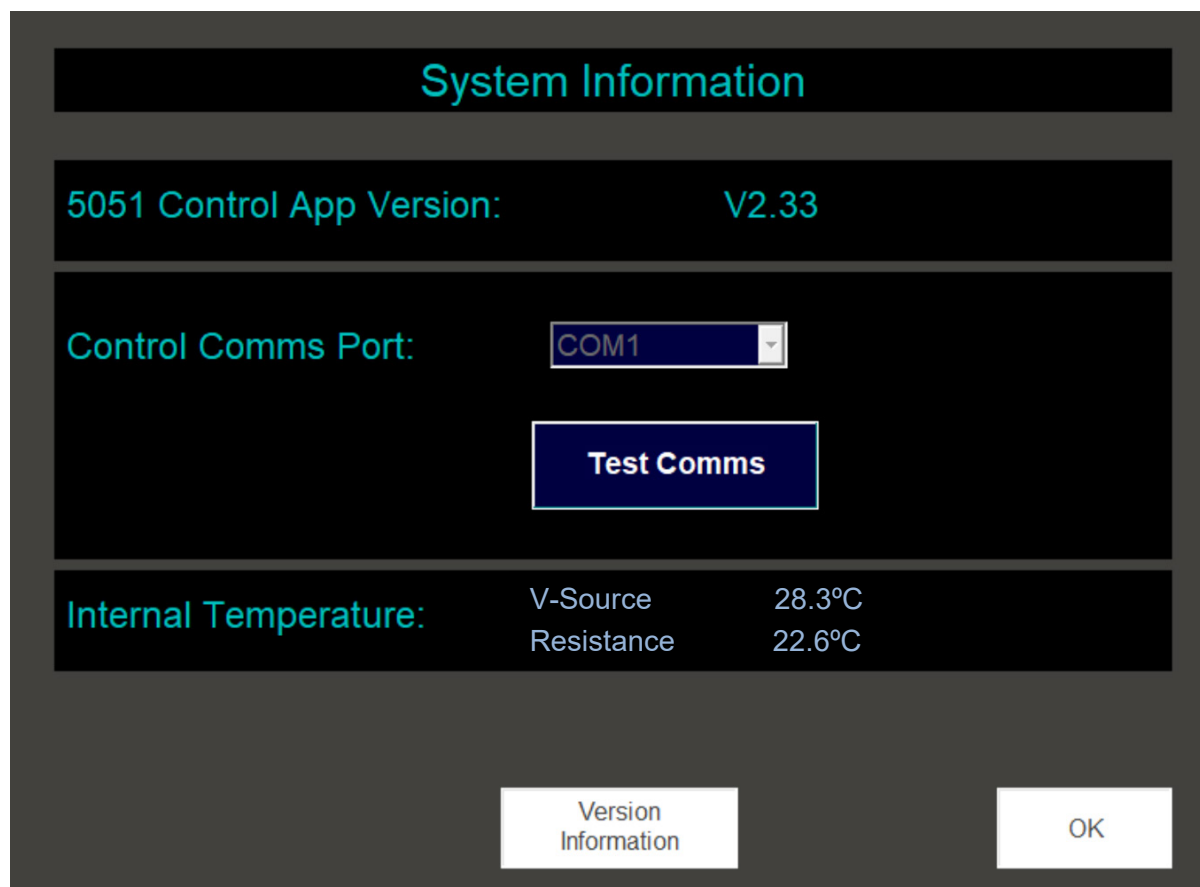

In the green band near the top of the screen is displayed the version number of the control program itself (e.g. V1.61 in the screenshot above).

The blue rectangle in the middle of the screen shows the internal comms port used to communicate with the xx51's own hardware. The comms port is fixed and cannot be changed. Pressing the **Test Comms** button will test communication with the hardware. If the test is OK, then this window will be displayed:

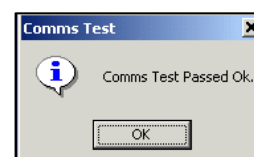

At the bottom of the screen are shown the internal temperatures of the xx51's voltage source module and the resistance source module.

By pressing the Version Information button on this screen, more detailed version information about the xx51 will be displayed:

The left hand side of the window shows the version of the software driver installed.

In the main white area of the window are shown the version numbers of the xx51's modules. The ID column shows the module's identity code. The Address column shows its internal address, and the Version column shows the module's firmware version number.

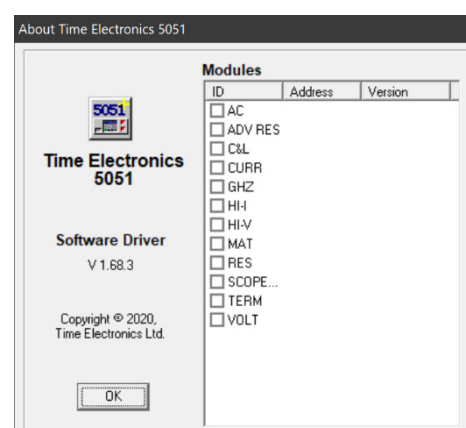

## 7.11. Operating the xx51 as a Multimeter

To use the xx51 as a multimeter, double-click the xx51 DMM icon on the Windows desktop. A screen will appear as below:

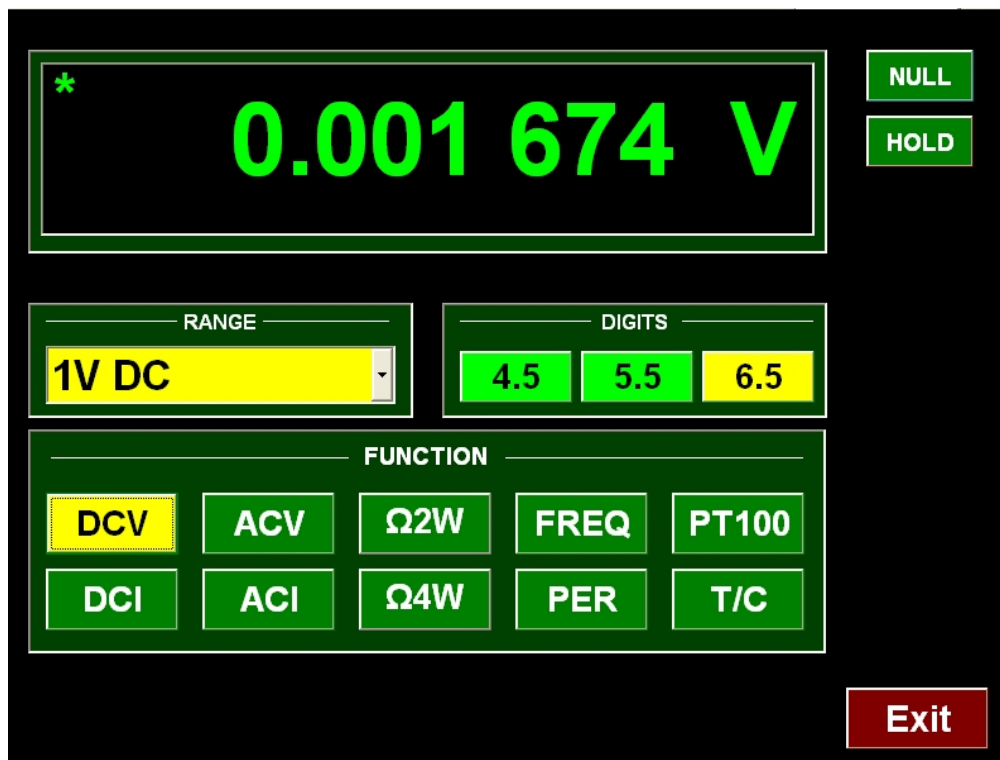

Use only the 'DMM' terminals of the xx51 for measurements in Multimeter mode. The LED beside the Input terminals will light to indicate that the xx51 is in Multimeter mode.

While the xx51 is in Multimeter mode it will take readings continuously at regular intervals. Each time a reading is taken a green star at the top left of the reading window will flash.

### 7.11.1. Selecting Measurement Function

The following functions are available:

- DC Volts (DCV)
- AC Volts (ACV)
- DC Current (DCI)
- AC Current (ACI)
- Resistance ( $\Omega$ 2W)
- 4 Wire Resistance ( $\Omega$ 4W)
- Frequency (FREQ)
- Period (PER)
- Thermocouples (T/C)
- PT100 (PT100)

The selected function is indicated by the highlighted button in the screen area labelled "Function". To change function, click the required function button.

### 7.11.2. Selecting Range

The ranges available depend on the function selected. The ranges available are:

Function	Ranges
DC Volts	100mV, 10mV, 1V, 10V, 100V, 1kV
AC Volts	100mV, 10mV, 1V, 10V, 100V, 1kV
DC Current	10mA, 100mA, 1A, 3A
AC Current	1A, 3A
Resistance	100R, 1kR, 10kR, 100kR, 1MR, 10MR, 100MR
Frequency	10Hz, 100Hz, 1kHz, 10kHz, 100kHz, 1MHz
Period	5ms to 3us
Thermocouples	K, E, J, N, R, S & T
PT100	4 wire. -240°C to 850°C

To change range, click on the drop down arrow button adjacent to range window. The available ranges will be shown in a list and the desired range can be selected.

### 7.11.3. Selecting Display Resolution

The xx51 Multimeter is able to display its readout at three resolutions:

- 4.5 digits
- 5.5 digits
- 6.5 digits

By default, it will display using 6.5 digits.

The selected resolution is indicated by the highlighted button in the area labelled “Digits” (e.g. in the screen picture above, 6.5 digits are selected).

To change the number of digits displayed, click on the required button.

**Note:** The maximum number of digits is restricted for some functions and ranges by the accuracy and stability specification of the xx51.

#### 7.11.4. Reading Hold

If you wish to hold the display reading, click on the **HOLD** button. To indicate that Hold is active, the **HOLD** button will be highlighted and a **HOLD** annunciator will light up in the display window:

While in **HOLD** state, no further readings will be taken – the green star in the display window will not flash and the value in the reading window will remain unchanged from the last value read before the **HOLD** button was pressed.

To release **HOLD** and begin taking readings again, click the **HOLD** button again. Note that **HOLD** will also be released if a new range or function is selected.

#### 7.11.5. Nulling a Reading

The xx51 multimeter includes a **NULL** feature to allow backing off a reading, e.g. for cancelling out end or lead resistances.

When you click the **NULL** button, the current reading becomes zero and all future readings displayed are subtracted from this value.

For example, to measure the resistance of a component without measuring the resistance of the connecting leads,

1. With the **Ω2W** function selected, select the required range.
2. Short the connecting leads together at the point where they will connect to the component. The display will then indicate the lead resistance.
3. Click the **NULL** button once. The message “Null On...” will appear for approx. 2 secs, the **NULL** button will highlight and a “**NULL**” annunciator will appear in the display window. Remove the short from the leads and connect the component.
4. The reading displayed will be the component resistance only and not include the lead resistance.

To remove **NULL** click again on the **NULL** button. Please note that unlike the HOLD feature **NULL** is not cancelled when a new range is selected but is cancelled if a new function is selected.

#### 7.11.6. Thermocouples and CJC

The xx51 DMM control has a Cold Junction Compensation feature.

**Auto:** The xx51 uses an internal temperature sensor.

**Manual:** The user enters the cold junction value manually via the keypad

**Off:** No compensation.

If a 7085 temperature distribution panel is fitted the option to take the CJC value from here is also available.

#### 7.11.7. Exiting xx51 Multimeter Mode

Click once on the **EXIT** button. You will be returned to the Windows desktop.

## 8. EasyCal Software

EasyCal Software is supplied as standard with the xx51Plus. It is pre-loaded on the control centre PC and configured for use upon start up.

Full details of how to use the software are provided in the separate EasyCal manual.

Summary of the EasyCal programs:



The complete suite of programs comprises of:

### EasyEdit

- **System Setup**
  - Specification of general laboratory information.
  - Specification of laboratory environmental conditions.
  - Specification of default information for Calibration Certificates.
- **Instruments** - allows instruments/items for calibration to be created and/or edited.
- **Procedures** - allows calibration procedures to be created and/or edited

**CalRun** - the actual calibration process with an intuitive, graphical user-interface.

**PrintCert** - recalls and prints calibration certificates from the Results database. A standard certificate format is supplied. Produces traceable certificates to ISO 9000, UKAS or other international standards. With Crystal Reports (optional) the user has the option to change or redesign the certificate

Example steps for using EasyCal to automate calibration work on the CalBench with xx51Plus.

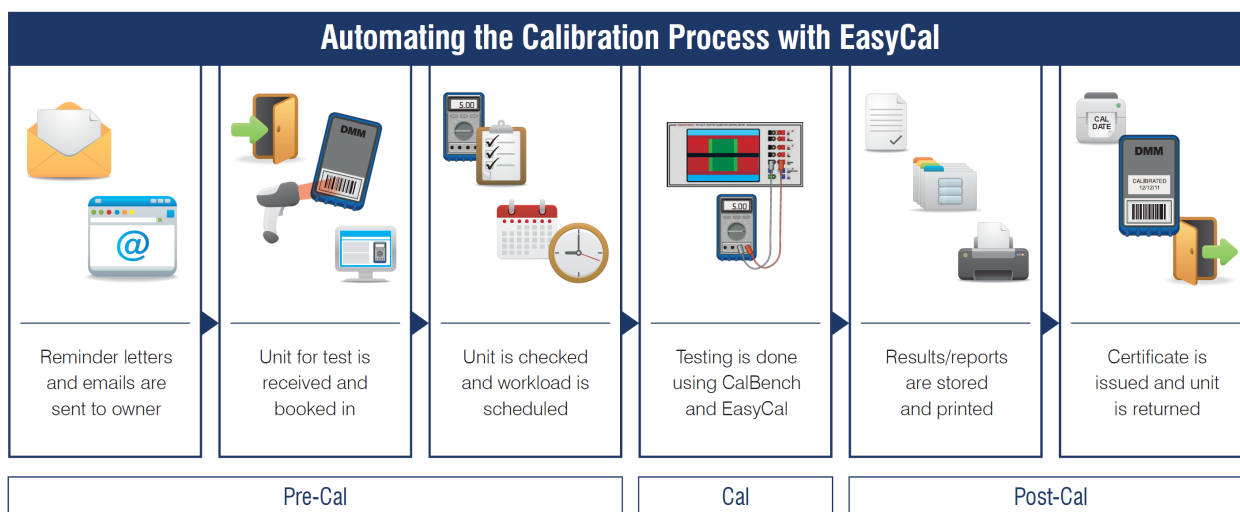

## 9. 7051 Pressure Control Centre



If the CalBench features pressure modules RMTEG, MTEG or XTEG, the 7051 control centre will also feature a “Pressure Control Centre” application that can be accessed from the start menu by selecting this icon:



The application provides a readback display via the control centre module.

*Note that the application is only present when compatible pressure modules are integrated in the same CalBench console.*

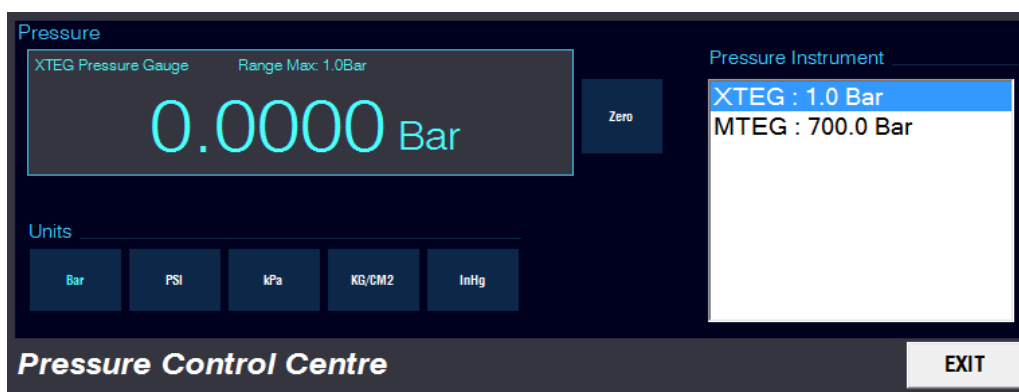

RMTEG Regulated Gauge Modules

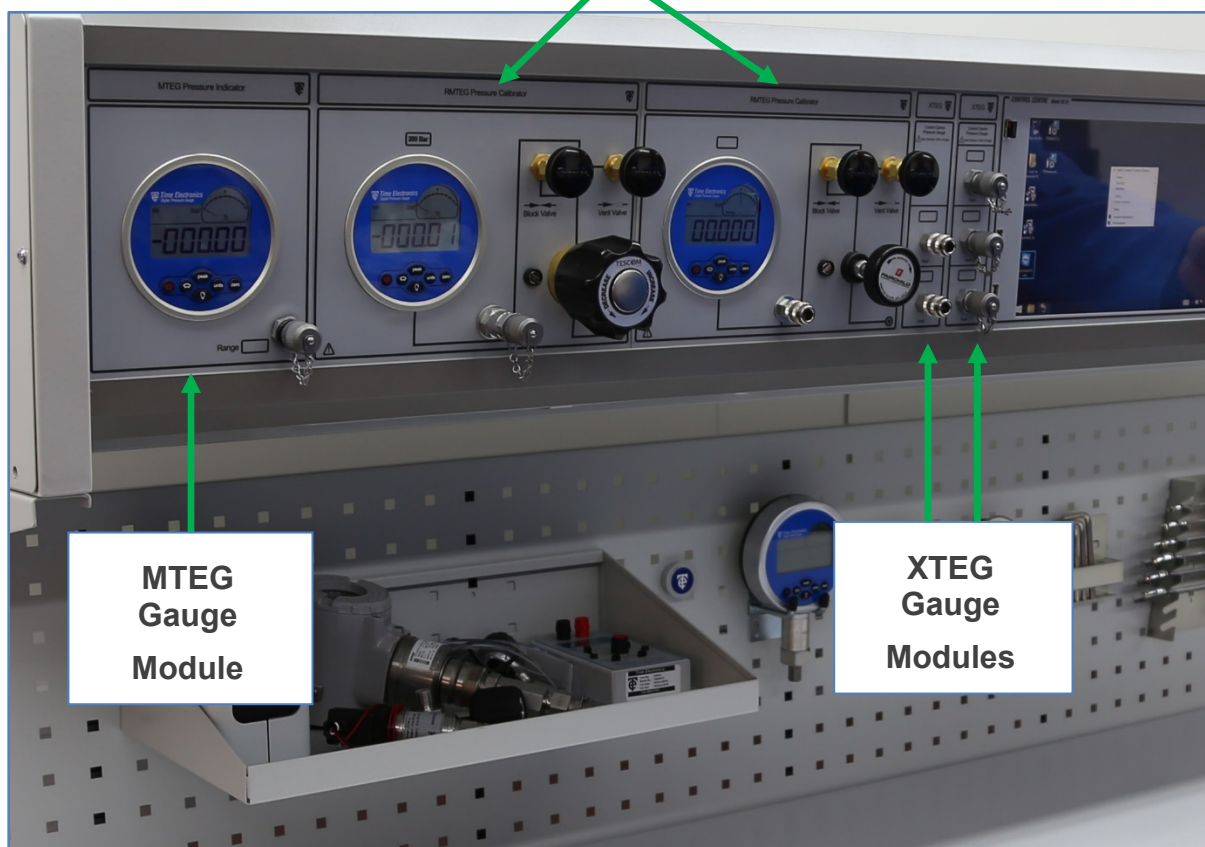

## 9.1. Controls



To view a pressure measurement; follow these steps:

1. Select the pressure module and port range from the Pressure Instrument list.
2. Touch the required units button for measurement.

For gauge measurements the reading should be zeroed before performing measurements:

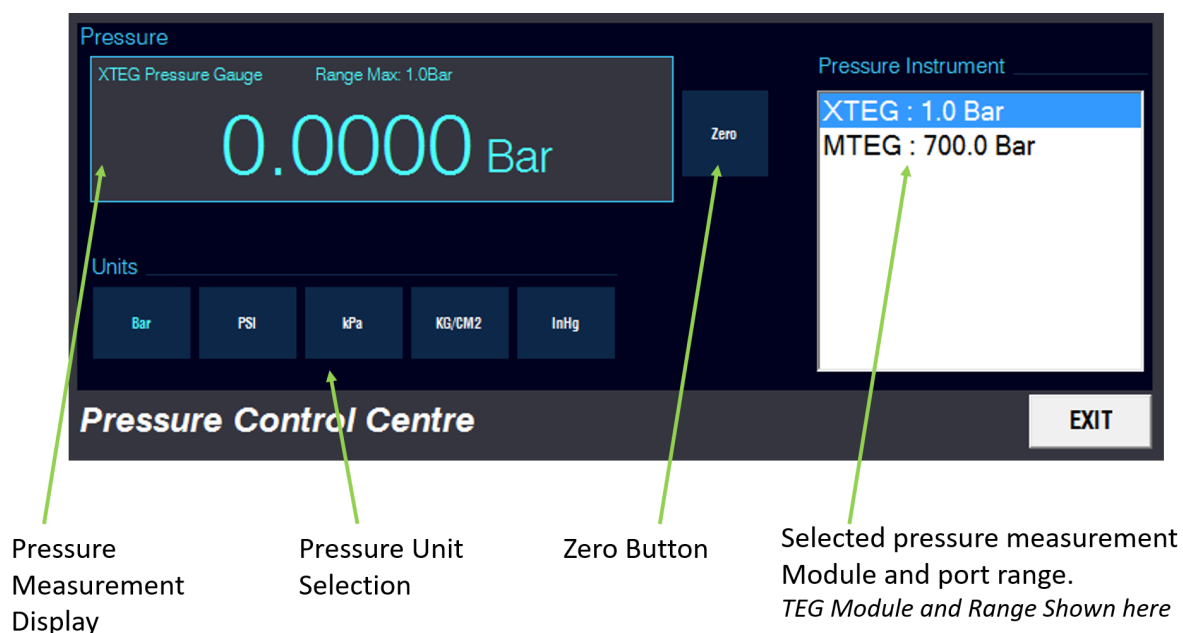

1. Vent the input of the pressure port to atmospheric pressure.
2. Ensure the reading is settled to near zero.
3. Touch the zero button to reset the instrument to zero.

Note: RMTEG and MTEG modules have a primary display on the gauges. The Pressure Control Centre provides an additional display, commonly utilised with pressure transmitter calibration.





## 10. Included Accessories

Item Description and Purpose	Photo
<p><b>9796 Test Lead Set</b> Test leads used for connecting to various units under test, from the xx51 source and measure panel.</p>	
<p><b>9780 Clamp Meter Adaptor</b> Used for calibrating clamp meters.</p>	
<p><b>9773 Optical Tacho Adaptor</b> Used for calibrating optical tachometers.</p>	

**7112 Transducer Patch Box (7051 Only)**

Provides convenient connection for transducers under test, with 250Ω resistor.



**9795 Printer and Connectivity Kit**

USB keyboard and mouse, Inkjet Printer, Cal and ID Label Printer, 4 port USB hub, Numeric keypad, USB memory stick.



**9777 Bar Code Reader**

Used to read bar codes placed on instruments/devices for quick identification into EasyCal calibration software.



**9778 Label Printer**

For printing 'Calibrated' labels to be placed on instruments before leaving the laboratory. Print ID labels with bar codes to enable fast identification using the 9777 bar code reader and EasyCal.



## 10.1. Using the 9780 Clamp Meter Adaptor

The 9780 is an adaptor used when calibrating clamp meters.

Connect the clamp meter adaptor x50 coil to the xx51 Hi Current terminals.

Place the clamp meter on the bed, with the jaws clamped around the coil.

Make sure the coil is aligned centrally with the markers on the jaws.

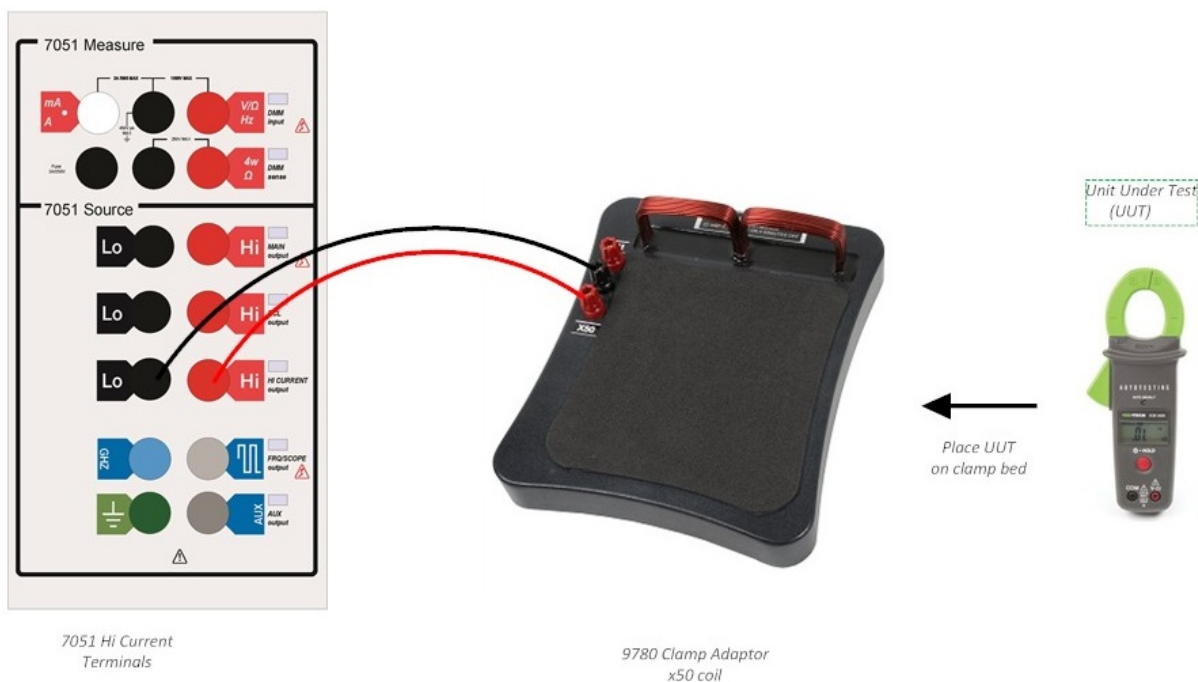

Select the **A** function on the dial of the Clamp Meter.  
Example: On the xx51, source AC current 1.2 A, 50 Hz.  
Note the Clamp adaptor multiplier:  $1.2 \times 50 = 60$  A.

7051 Output Setting	Clamp Meter Reading
<p>The screenshot shows the 7051 Output Setting screen. The main display shows '1.2000 A' in large blue digits. Below it, 'AC Current' and '2A Range' are displayed. To the right, 'Dev ---' and '200 Hz' are shown. The keypad includes digits 0-9, a 'C' button, and function buttons for <math>\mu</math>A, mA, and A. There are also buttons for 'x 10', '<math>\div</math> 10', and 'Hz'. At the bottom, there are buttons for '+ve DEV', 'zero DEV', '-ve DEV', 'DMM', 'Zero Output', and 'MENU'.</p>	<p>The screenshot shows the Clamp Meter Reading screen. The main display shows '60.00' in large green digits.</p>

## 10.2. 7112 Transducer Patch Box (7051 Only)

When testing instrumentation such as pressure transmitters you will use a combination of modules.

The optimal set up utilizes the **7112 transducer patch box** also.

Connect a DC power supply (24V common) to the Patch Box “PSU” sockets.

Connect the Patch Box “UUT” sockets to the transmitter under test.

Connect the Patch Box “DMM” sockets to the 7051 mA Measure section.

Apply pressure to the transmitter with a pressure module such as 8030B or RMTEG.

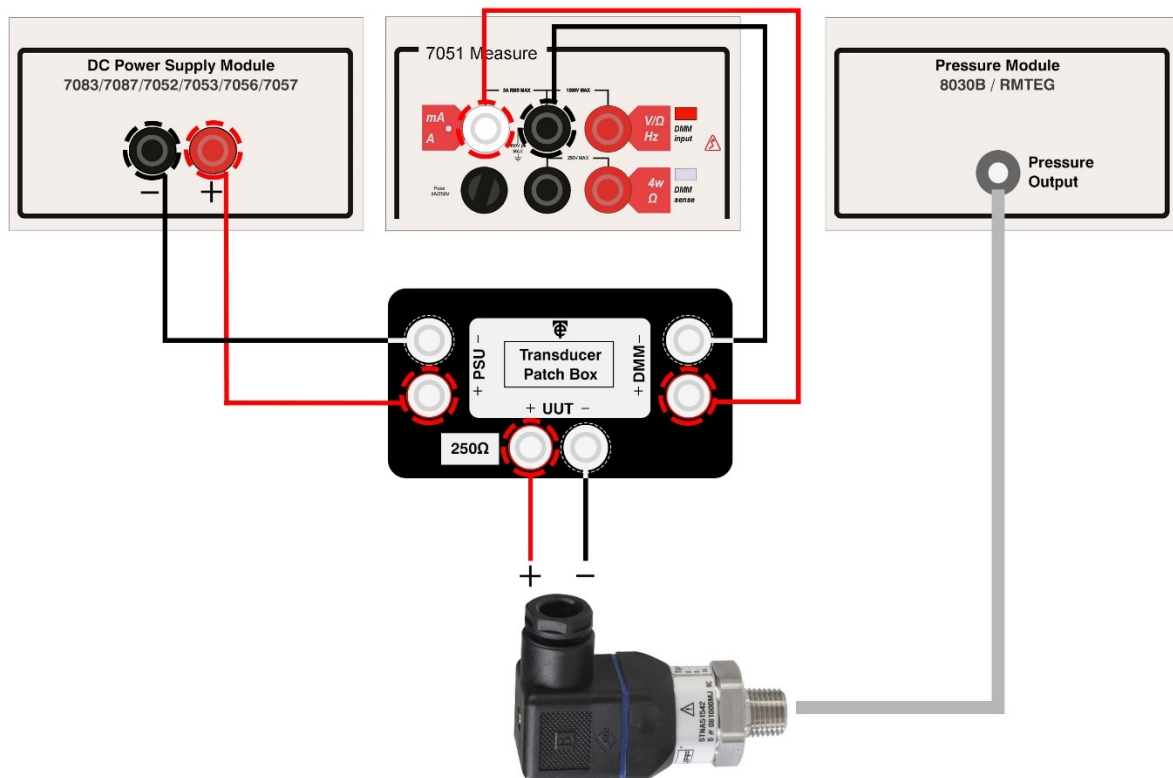

### 10.3. 7051 CCPAD Option

The CCPAD is a common accompanying module for the 7051Plus. It's primary operation is with EasyCal software. Please see the CCPAD user manual for further details.

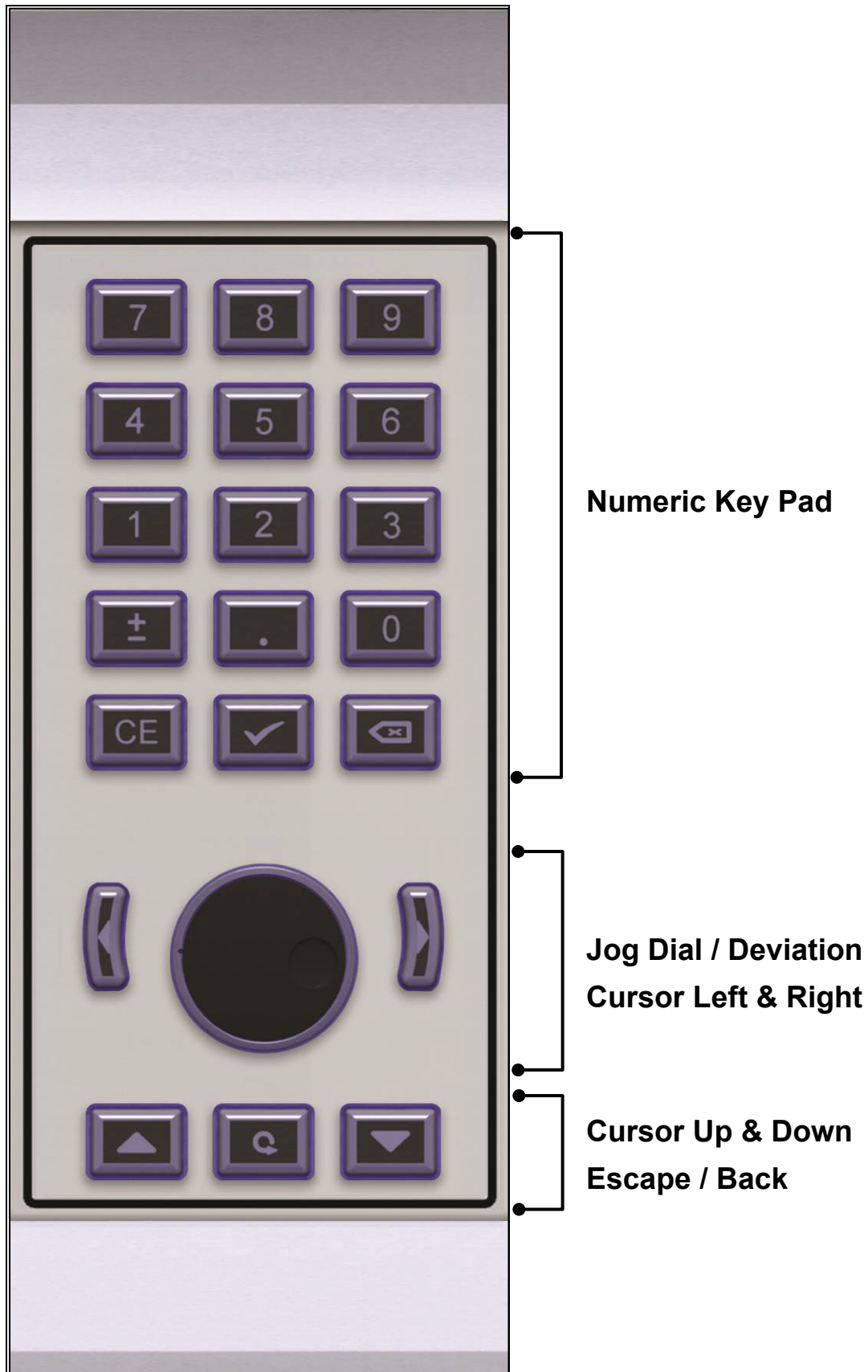

## 11. Re-Calibration

Calibration of the xx51 is performed using a program to adjust the internally stored calibration factors, no hardware adjustments are required and it is not necessary to dismantle the instrument.

A separate Calibration Manual is available from Time Electronics or their authorised dealer on request.

## 12. Fault Diagnosis



*Operations involving the removal of the top cover. Before proceeding, ensure that the mains supply and any inputs have been disconnected. Failure to do so may expose live terminals and present an electrical shock hazard.*

### 12.1. Fault Check List

#### **Mouse, Keyboard or Printer does not function**

Check that the USB connection cables are correctly located. Check that the 4 port USB hub is connected correctly.

#### **DMM Module fuses**

A 3.15A slow blow fuse protects the current measuring ranges from damage due to overload, and an 8A anti-surge fuse protects the mains power unit.

The DMM module is located in the primary console and is accessed by first removing the console top cover. It is a white module located on left side of the rear panel near to the console exhaust fan. The module has 2 fuse holders which are labelled with the appropriate values.

#### **Mains generated interference**

It is recommended that the xx51 be operated from a clean AC mains power supply. It is strongly recommended that a filtered mains stabilizer is used. The effects of interference entering the xx51 are crashing of the control PC and malfunction of one of more of the many microcontrollers located inside the unit.

Time Electronics maintain a technical support service and in the event of difficulty we are ready to provide technical advice by telephone, fax, or email.

## 13. Warranty and Servicing

### Warranty

The Time Electronics products carry a one-year manufacturer's warranty as standard.

Time Electronics products are designed and manufactured to the highest standards and specifications to assure the quality and performance required by all sectors of industry. Time Electronics products are fully guaranteed against faulty materials and workmanship.

Should this product be found to be defective, please contact us using the below details. Inform us of the product type, serial number, and details of any fault and/or the service required. Please retain the supplier invoice as proof of purchase.

This warranty does not apply to defects resulting from action of the user such as misuse, operation outside of specification, improper maintenance or repair, or unauthorized modification. Time Electronics' total liability is limited to repair or replacement of the product.

Note that if Time Electronics determine that the fault on a returned product has been caused by the user, we will contact the customer before proceeding with any repair.

### Calibration and Repair Services

Time Electronics offers repair and calibration services for all the products we make and sell. Routine maintenance by the manufacturer ensures optimal performance and condition of the product. Periodic traceable or accredited calibration is available.

### Contacting Time Electronics

**Online:**

Please visit [www.timeelectronics.com](http://www.timeelectronics.com) and select Support Request from the Contact links. From this page you will be able to send information to the Time Electronics service team who will help and support you.

**By phone:**

+44 (0) 1732 355993

**By email:**

[mail@timeelectronics.co.uk](mailto:mail@timeelectronics.co.uk)

## Returning Instruments

Prior to returning your product please contact Time Electronics. We will issue a return merchandise authorization (RMA) number that is to accompany the goods returning.

Further instructions will also be issued prior to shipment. When returning instruments, please ensure that they have been adequately packed, preferably in the original packing supplied.

**Time Electronics Ltd will not accept responsibility for units returned damaged.**

Please ensure that all units have details of the service required and all relevant paperwork.

Send the instrument, shipping charges paid to:

### **Time Electronics Ltd**

Unit 5, TON Business Park, 2-8 Morley Road,  
Tonbridge, Kent, TN9 1RA.  
United Kingdom.

Tel: +44(0)1732 355993

Fax: +44(0)1732 350198

Email: [mail@timeelectronics.co.uk](mailto:mail@timeelectronics.co.uk)

Web Site: [www.timeelectronics.com](http://www.timeelectronics.com)

---

## Disposal of your old equipment



1. When this crossed-out wheeled bin symbol is attached to a product it means the product is covered by the European Directive 2002/96/EC.
2. All electrical and electronic products should be disposed of separately from the municipal waste stream via designated collection facilities appointed by the government or the local authorities.
3. The correct disposal of your old appliance will help prevent potential negative consequences for the environment and human health.
4. For more detailed information about disposal of your old appliance, please contact your city office, waste disposal service or return to Time Electronics.