



Level



Pressure



Flow



Temperature

Liquid
Analysis

Registration

Systems
Components

Services



Solutions

Technical Information

Omnigrad S TC66

Thermocouple thermometer EEx-d certified, replaceable insert, thermowell from bar stock, process connection: threaded or flanged PCP (4...20 mA), HART® or PROFIBUS-PA® electronics



Range of uses

The Omnigrad S TC66 is an industrial thermometer (thermocouple TC: K or J) with a replaceable inset, a neck and a thermowell from bar stock.

It is developed for the use in the chemical, petrochemical and energy industries, but suitable also for other generic heavy duty applications.

In compliance to EN 50014/18/20 (ATEX certification) it is therefore particularly suitable also for hazardous areas.

When required, it's also available with a transmitter (PCP, HART® or PROFIBUS-PA®) into the housing.

The process connection of the thermowell is threaded or flanged in compliance to the standard of process requirements.

Application areas

- Chemicals industry
- Energy industry
- Gas Processing industry
- Petrochemical industry
- General industrial services

Features and benefits

- Several types of process connection
- Several type of materials available for the thermowells
- Customized immersion length
- Aluminium housing, with protection grade from IP66 to IP68
- Thermocouple with hot junction grounded or ungrounded in mineral oxide cable (MgO cable) diameter: 3 or 6 mm
- PCP, HART® and PROFIBUS-PA®, (4...20 mA 2-wire transmitters)
- The accuracy of the thermocouple TC (K (NiCr-Ni) and J (Fe-CuNi)) are: Cl. 1 - 2 (EN 60584) or Cl. Special - Standard (ANSI MC96.1)
- The thermocouple TC (K or J) are available in single or double element
- ATEX II 2 GD EEx-d IIC certification
- ATEX II 1/2 GD EEx d IIC certification



Function and system design

Measuring principle

The thermocouple (TC) thermometer's sensing element consists of two metal wires that are homogeneous but different one from the other and insulated along their entire length. The two wires are welded together at one end, known as the "measurement or hot junction". The other end, where the wires are free, is known as the "cold or reference junction" and is connected to an electromotive force measurement circuit where the force is generated by the different thermoelectric power of each of the thermocouple's wires if there is a temperature difference between the hot joint (T1) and the cold joint (Seebeck effect). The cold junction has to be "compensated" with reference to the temperature of 0°C (T0). The function that links the electromotive force to the temperatures T1 and T0 is a curve whose characteristics depend on the materials used in the construction of the thermocouple. Some thermocouples curves, and particularly those most reliable for the purposes of industrial readings, are those compliant with standards DIN EN 60584 and ANSI MC96.1.

Equipment architecture

The construction of the TC66 temperature sensor is based on the following standards:

- EN 50014/18 (housing)
- Neck (1 or 2 nipple and 1 "3 union")
- EN 60584 (insert).
- Thermowells standard like: ASTM, DIN, ESSO, ENI, MONTEDISON, ENEL, etc.

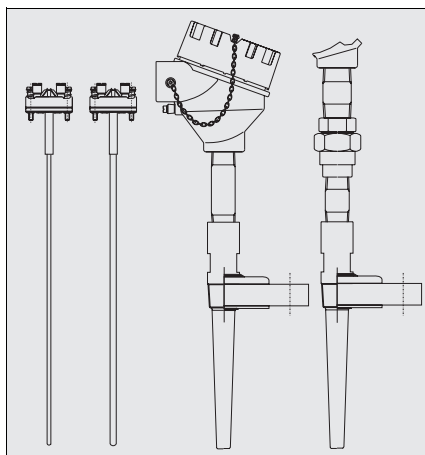

Fig. 1: TC66 with the various types of process connections and end parts of the probe

The housing is in painted aluminium alloy; it is suitable to contain a transmitter and/or the ceramic block of the insert; the "Ingress Protection" is from IP66 to IP68.

The neck composed by one or two nipple and one "3 union", standard or EEx- execution, it is the extension between the head and the thermowell.

The hot junction of the thermocouple (type K or J) are positioned close to the tip of the probe. The thermocouple is available in two versions: grounded or ungrounded hot junction.

The electrical structure of the thermocouple always complies with EN 60584/61515 or ANSI MC96.1/ASTM E585 standard rules.

The thermowell is from bar stock, with wetted part, conical, straight or tapered. The process connection is: threaded or flanged, in some case it can be to weld also.

Material & Weight

Housing	Insert	Neck	Thermowell	Weight
aluminium epoxy coated	sheath in: SS 316L/1.4404 Inconel®600/2.4816	nipple and 3 union : SS 316/1.4401 or A105	thermowells: SS 316/1.4401, SS 316Ti /1.4571, (Hastelloy C276/2.4819, Monel® 400/2.4360, Inconel® 600/2.4816.)	From 1.5 to 5.0 kg for standard options

Performance

Operating conditions

Operating condition or test	Product type or rules	Value or data of test
Ambient temperature	housing (without head-mounted transmitter)	-40÷130°C
	housing (with head-mounted transmitter)	-40÷85°C
Process temperature	It is restricted by the thermowell material:	< 600°C
		< 800°C
		< 1100°C
Process pressure (Maximum)	The pressure values to which the thermowell can be subjected at the various temperatures are illustrated by the drawings in fig. 2.	SS 316L/1.4404 SS 316Ti/1.4571 Hast.® C276/2.4819 - Inc.600®/2.4816
Maximum flow velocity	The highest flow velocity, (of the stream or of the fluid), tolerated by the thermowell, diminishes with increasing lengths, of the thermowell/probe exposed (fig. 2).	
Shock and vibration resistance test	TC Inset in according to the rule IEC 60751:	Acceleration
		Frequency
		Time test

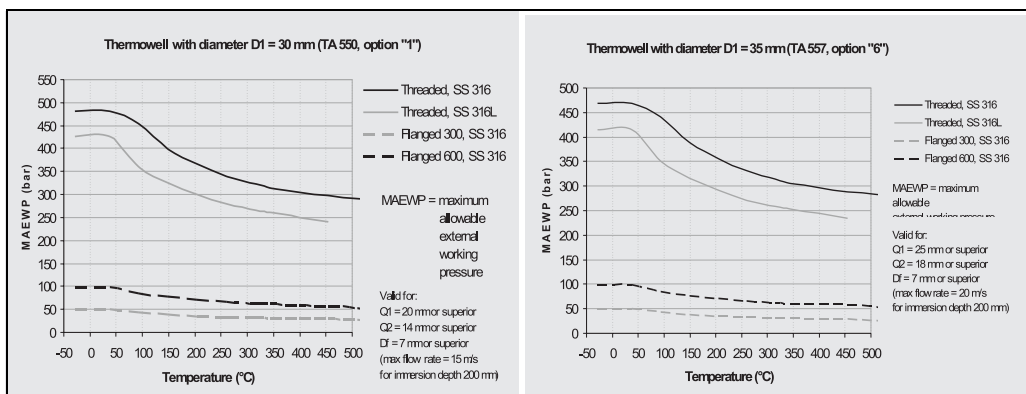

Fig. 2: Pressure/temperature graphic for thermowell from bar stock

Accuracy

Thermocouple and range °C	EN 60584				
	Class	Max deviation	Class	Max deviation	Cable colors
J (Fe-CuNi) -40° ... 750°C	2	+/-2.5°C (-40...333°C) +/-0.0075 Itl (333...750°C)	1	+/-1.5°C (-40...375°C) +/-0.004 Itl (375...750°C)	+ black - white
K (NiCr-Ni) -40 ... 1200°C	2	+/-2.5°C (-40...333°C) +/-0.0075 Itl (333...1200°C)	1	+/-1.5°C (-40...375°C) +/-0.004 Itl (375...1000°C)	+ green - white

Itl = absolute temperature value in °C

Thermocouple and range °C	ANSI MC96.1				
	Class	Max deviation	Class	Max deviation	Cable colors
J (Fe-CuNi) 0 ...750°C	Standard	+/-2.2°C (0...293°C) +/-0.75% (293...750°C)	Special	+/-1.1°C (0...275°C) +/-0.4% (275...750°C)	+ black - red
K (NiCr-Ni) 0...1250°C	Standard	+/-2.2°C (0...293°C) +/-0.75% (293...1250°C)	Special	+/-1.1°C (0...275°C) +/-0.4% (275...1250°C)	+ yellow - red

Itl = absolute temperature value in °C

Others errors	
Transmitter maximum error	See the corresponding documentation (codes at the end of the document)
Display maximum error	0.1% FSR + 1 digit (FSR = Full Scale Range)

Response time

Tests, with the TC insert, in water at 0.4 m/s (according to IEC 60751) from 23 to 33°C:

Stem diameter of the insert	Sensing element type	Temperature of test	Response time
SS 316 - d. 6 mm	K (NiCr-Ni)	t ₅₀	2,5 s
	J (Fe-CuNi)	t ₉₀	7,0 s

Insulation

Measurement Insulation type	Result
Insulation resistance between terminals and probe sheath according to EN 60584, test voltage 500 V	> 1 GΩ at 25°C > 5 MΩ at 500°C

Self heating

Negligible when the E+H iTEMP® transmitters are employed.

Installation

The TC66 can be installed on pipes, tanks or other heavy duty applications, by means of threaded or flanged connections. The counterparts for process connections and gaskets, when required, are not supplied with the sensor and must be purchased separately by the user. The immersion length must take into account all the parameters of the thermometer and the process to measure. If the immersion is too low, an error may be generated in the temperature recorded due to the lower temperature of the process fluid near to the walls and heat transfer, which takes place through the sensor stem. The incidence of such an error can be not negligible if there is a big difference between the process temperature and the ambient temperature. To prevent measuring errors of this kind, it is advisable to use thermowells with a small diameter and an immersion length (U) of at least $100 \div 150$ mm. In small section ducts the tubing's axis must be reached and preferably slightly exceeded by the tip of the probe (see fig. 3A-3C). Insulation of the outer part of the sensor reduces the effect produced by a low immersion. Alternatively, it is also possible to adopt a tilted installation (see fig. 3B-3D).

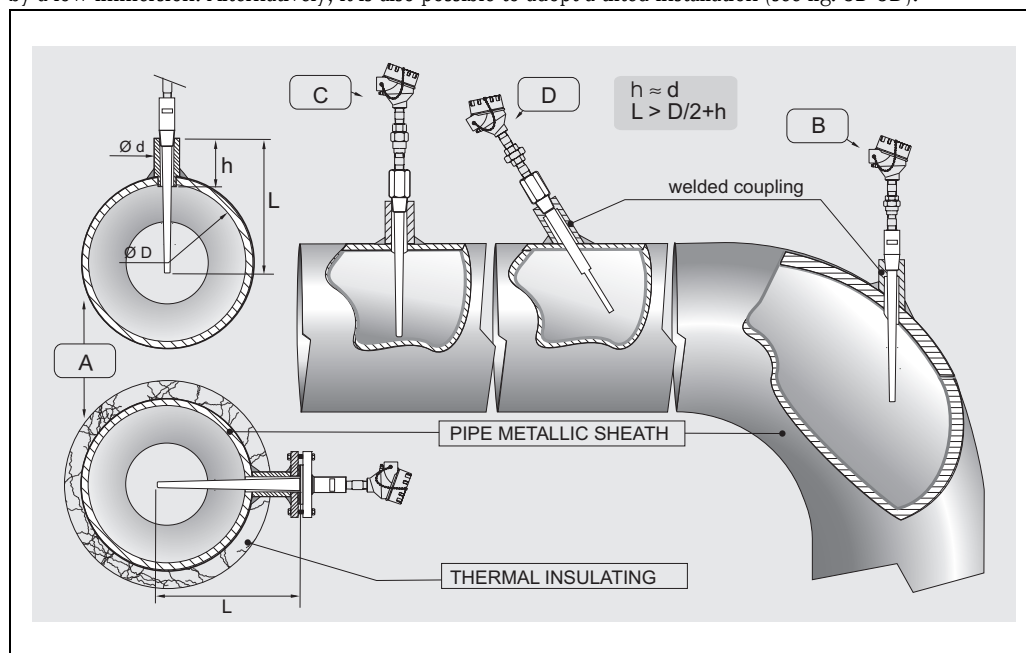

Fig. 3: Installation examples

For a best installation, in the industries, it's better to follow the rule: $h \approx d$, $L > D/2 + h$. As far as corrosion is concerned, the base material for parts in contact with the fluid is able to withstand the most common corrosive agents up to the highest temperatures. Even the nipples and 3 elements coupling supplied with the connection fitting of the instrument are able to withstand a wide range of aggressive substances. With regard to corrosion, the base material of the wetted parts (SS 316L, SS 316Ti, Hastelloy® C276 or Inconel®600) can tolerate the common corrosive media right up to even the highest temperatures.

For further information on specific applications, contact the E+H Customer Service Department. Disassembled components of the sensors must be reassembled with the recommended clamping torques in order to ensure the appropriate IP protection class within the sensor-housing coupling.

System components

Housing

The protection housing, our "TA21H", commonly referred to the "connection head", is used to contain and protect the terminal block or the transmitter and to join the electric connections to the mechanical component.

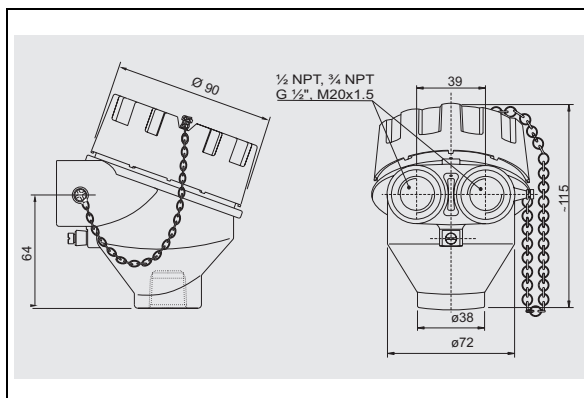

Fig. 4: Housing TA21H

The TA21H used for the TC66 is compliant with EN 50014/18 and EN 50281-1-1, EN 50281-1-2 standards (EEx-d certification for explosion proof type of protection).

The matching of the head with the extension below the head and the cover (threaded) ensures a degree of protection from IP66 to IP68.

The head also has a chain to connect the body to the cover, which facilitates the use of the instrument during the maintenance on systems. The single or double threaded electrical cable entry can be: M20x1.5, 1/2" NPT or 3/4" NPT, G1/2".

Extension neck

A special extension is inserted between the husing and the thermowell connection, this part is called neck. The neck is constituted by a tube assembled to hydraulic hardware (nipples or joints) that is suitable to allow the adjustment of the sensor to the thermowell.

In addition to the standard versions listed below, it is also possible to order the extension neck by specifying the desired length (see "Sales structure" chart at the end of this document). In the TC66 the standard lengths (N) and the versions of the extension neck can be selected among the following options:

Tp	Material	N length mm	Thread	C mm	Neck dwg type
N	316	69	1/2" NPT M	8	A
N	316	109	1/2" NPT M	8	A
NUN	316	148	1/2" NPT M	8	F
N	A105	69	1/2" NPT M	8	A
N	A105	109	1/2" NPT M	8	A
NUN	A105	148	1/2" NPT M	8	F

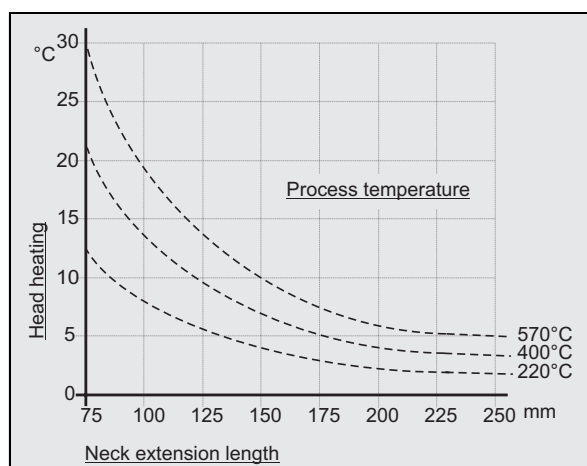
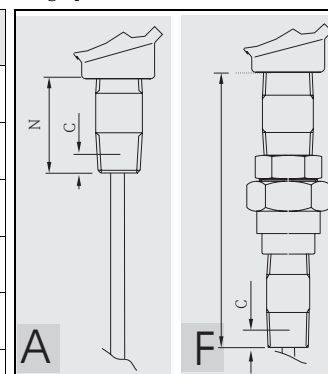

As illustrated by the drawing in fig. 5, the length of the extension neck may influence the temperature in the head. It is necessary that this temperature is kept within the limit values defined in the paragraph "Operating Conditions".

Before choosing the connection, it is better to verify this graphic and therefore to choose a suitable extension to avoid the heating of the head.

Fig. 5: Heating of the head caused by the process temperature

Electronic head transmitter

The required type of output signal can be obtained by choosing the correct head mounted transmitter. Endress+Hauser supplies “state-of-the-art” transmitters (the iTEMP® series) built in 2-wire technology and with 4...20 mA output signal, HART® or PROFIBUS-PA®. All of the transmitters can be easily programmed using a PC:

Head transmitter	Communication software
PCP TMT181	ReadWin® 2000
HART® TMT182	ReadWin® 2000, FieldCare, Hand held module DXR275, DXR375
PROFIBUS PA® TMT184	FieldCare

In the case of PROFIBUS-PA® transmitters, E+H recommends the use of PROFIBUS® dedicated connectors. The Weidmüller type is provided as a standard option. For detailed information about transmitters, please refer to the relevant documentation (refer to TI codes at the end of the document). If a head-mounted transmitter is not employed, the sensor probe may be connected through the terminal block to a remote converter (i.e. DIN rail transmitter). The customer may specify the configuration desired during the order phase. The head-mounted transmitters available are:

Description	Dwg
<p>TMT181: PCP 4...20 mA. The TMT181 is a PC programmable transmitters</p> <p>TMT182: Smart HART®. The TMT182 output consists of 4...20 mA and HART® superimposed signals.</p>	
<p>TMT184: PROFIBUS-PA®. For the TMT184, with PROFIBUS-PA® output signal, the communication address may be set via software or via mechanical dip-switch.</p>	

Thermowell

The thermowell is the component of the TC66 that must tolerate most of the mechanical stress transmitted by the process.

It is made from a round bar and supplied in different materials and dimensions, according the chemical/physical characteristics of the process: corrosion, temperature, pressure and speed of the fluid.

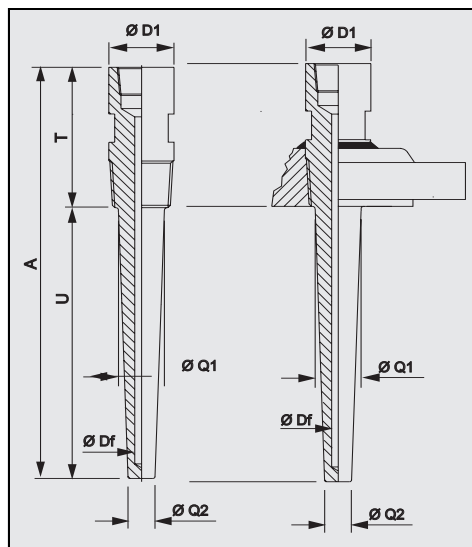

The thermowell consists of three parts:

- the extension neck (indicated as T), usually with a cylindrical shape (and standard diameters of 30 or 35 mm and lengths of 70/100 mm), represents the external part of the thermowell and is connected with the head of the probe by means of a neck (usually a nipple)
- the immersed part (identified as U), with a conical or cylindrical shape (the standard diameter of the area below the fitting is 20 or 25 mm), is situated next to the process connection in direct contact with the process fluid
- the threaded or flanged process connection represents the part inserted between the extension and the immersed part and guarantees the mechanical and hydraulic sealing of the thermometer and plant.

The external finishing of the thermowell stem is available with a standard value of Ra < 1.6 μm (different finishes are available on request).

Fig. 6: Thermowell with threaded or flanged process connection



Warning:

The total standard length (A) of the thermowell must never exceed 1200 mm (that represents the maximum drilling limit; higher lengths are available only on request).

Process connection

The standard process connections are threaded or flanged. When the process connection is threaded the material of connection is the same at the thermowell instead, when the process connection is flanged the material can be different: SS 316/1.4401 or ASTM A105/St 52.3.

When it is necessary to have a flange in special material, more resistant at the corrosion (example Hastelloy ©C276), it is cheaper to choose an economic version composed by a flange in SS316/1.4401 with on wetted part plated a disk in Hastelloy ©C276/2.4819 (this solution is very less expensive).

Type	Thread or Flange	Ø D1	Ø D2	Ø D3	Ø D4	D4 Nr	S1	S2	S3	A	A1
Flange	1" ANSI 150 RF SO	//	50,8	107,9	15,9	4	1,6	17,5	//	//	//
Flange	1" ANSI 300 RF SO	//	50,8	123,8	19,0	4	1,6	27,0	//	//	//
Flange	1" ANSI 600 RF SO	//	50,8	123,8	19,0	4	6,4	//	27,0	//	//
Flange	1" 1/2 ANSI 150 RF SO	//	73,0	127,0	15,9	4	1,6	22,2	//	//	//
Flange	1" 1/2 ANSI 300 RF SO	//	73,0	155,6	22,2	4	1,6	30,2	//	//	//
Flange	1" 1/2 ANSI 600 RF SO	//	73,0	155,6	22,2	4	6,4	//	31,7	//	//
Flange	2" ANSI 300 RF SO	//	92,1	165,1	19,0	8	1,6	33,3	//	//	//
Flange	2" ANSI 600 RF SO	//	92,1	165,1	19,0	8	6,4	//	36,5	//	//
All the dimension are in "mm"											
Thread	1/2" NPT	≥ 21,4	//	//	//	//	//	//	//	19,9	8,1
Thread	3/4" NPT	≥ 26,7	//	//	//	//	//	//	//	20,2	8,6

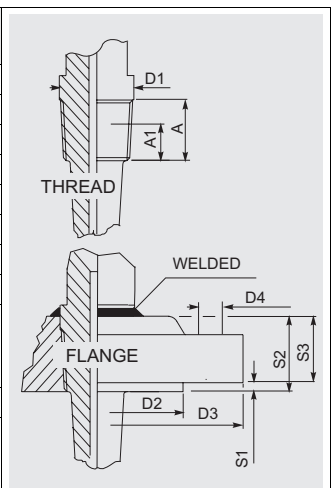

On request, it is possible to select also different materials, finishings and connections.

Probe

In the TC66 the measuring probe are two:

- the TPC100 (for general purpose application)
- the TPC300 (ATEX EEx d application)

Both of the probe are made in mineral insulated cable (MgO), with sheath in AISI316/1.4401 or Inconel®600. The Immersion length (U) of the thermometer can be chosen within a standard range from 50 to 1000 mm (see "Warning" in the "thermowell" section).

The thermometer with a Immersion length (U) > 1000 mm can be supplied after a technical verification of the specific applications from our technical office in the E+H Customer Service Department.

For replacement of the insert, it is necessary to refer the following table to have the IL (applicable only to standard thickness well bottoms). The immersion length of the insert spare part (IL) is calculated adding the total length of the thermowell (A = U + T) and the length of neck (N) used. Please refer the following table:

Insert general purpose	Ø, ..mm	N, tp.	N, mm	N, material	N, thread	IL, (mm)
TPR100	6	N	69	A105/SS316	1/2"NPT M	IL = U+T + 69 + 41
TPR100	6	N	109	A105/SS316	1/2"NPT M	IL = U+T + 109 + 41
TPR100	6	NUN	148	A105/SS316	1/2"NPT M	IL = U+T + 148 + 41

Insert ATEX EEx d	Ø, ..mm	N, tp.	N, mm	N, material	N, thread	IL, (mm)
TPR300	6	N	69	A105/SS316	1/2"NPT M	IL = U+T + 69 + 41
TPR300	6	N	109	A105/SS316	1/2"NPT M	IL = U+T + 109 + 41
TPR300	6	NUN	148	A105/SS316	1/2"NPT M	IL = U+T + 148 + 41

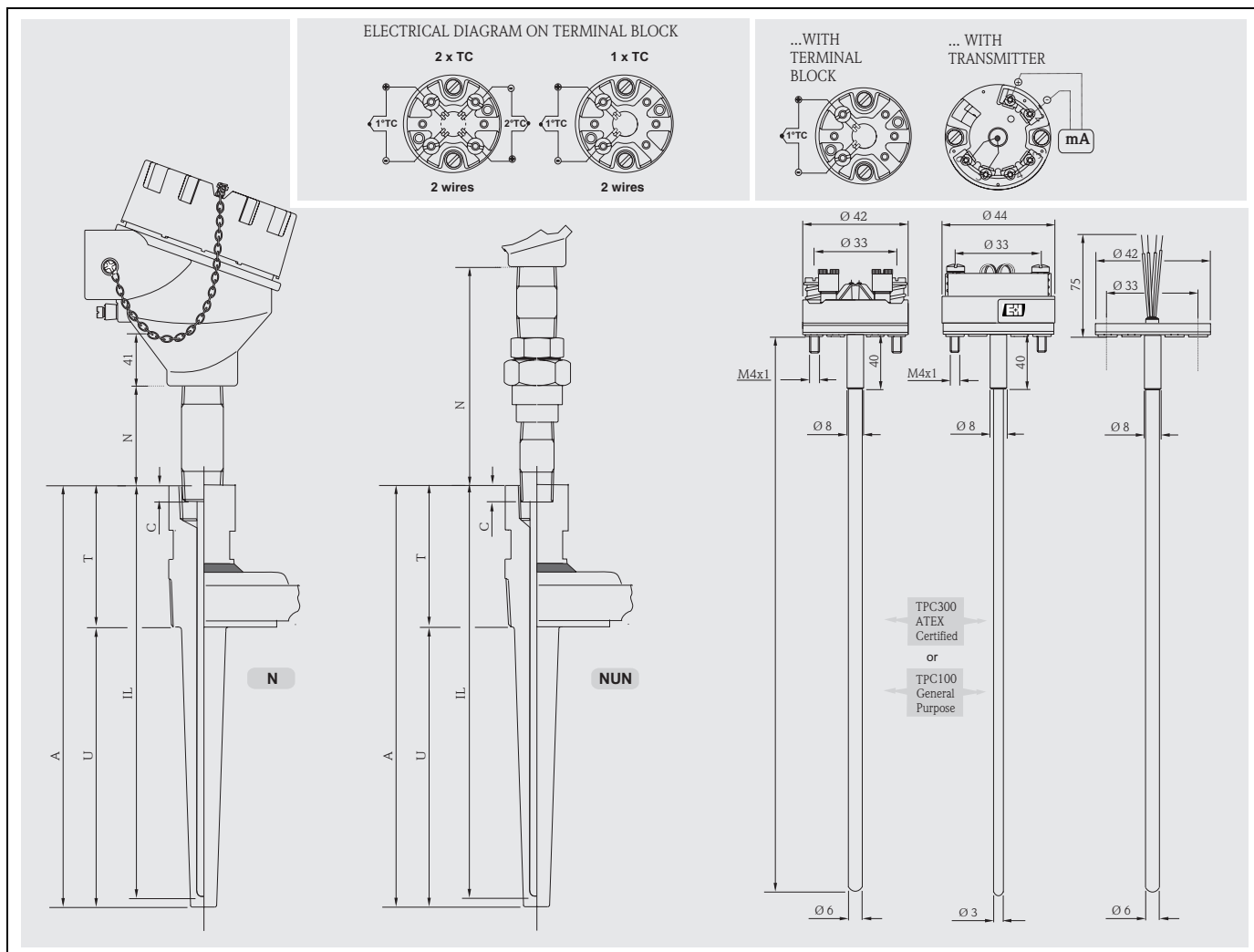

Fig. 7: Functional components, standard electrical diagrams (ceramic terminal block)

Certificates & approvals

Ex approval

■ ATEX Certificate CESI 05ATEX038 for explosion proof type of protection: ATEX II 2 GD EEx-d IIC T6..T5 T85°...T100°C. ATEX II 1/2 GD EEx-d IIC T6..T5 T85°...T100°C. The TC66 is **CE** marked.
With regards to the NAMUR NE 24 certificate and the Manufacturer's Declaration according to the standard EN 50018, EN 50020, EN 50281-1-1, EN 50281-1-2, E+H Customer Service will be able to provide further detailed information.

PED approval

The Pressure Equipment Directive (97/23/CE) is respected. As paragraph 2.1 of article 1 is not applicable to these types of instruments. The **CE** mark according to PED Directive is not requested.

Material certification

The material certificate EN 10204 3.1 can be directly selected from the sale structure of the product and refers to the parts of the sensor in contact with the process fluid.
Other types of certificates related to materials can be requested separately.
The "short form" certificate includes a simplified declaration with no enclosures of documents related to the materials used in the construction of the single sensor and guarantees the traceability of the materials through the identification number of the thermometer.
The data related to the origin of the materials can subsequently be requested by the client if necessary.

Test on thermowell

The pressure tests are carried out at ambient temperature in order to verify the resistance of the thermowell to the specifications indicated by the norm ASME PTC 19.3.
With regards to the thermowells that do not comply with this norm (with a reduced tip, a tapered tip on a 9 mm tube, special dimensions, etc.), the pressure of the corresponding straight tube with similar dimensions is verified. The sensors certified for use in Ex Zones, are always tested to pressure according to the same criterions.

Further details

Maintenance

The Omnigrad S TC66 thermometers do not require any specific maintenance.
In the case of ATEX certified components (transmitter, insert or thermowell) please refer to the corresponding specific relevant documentation (at the end of the document).

Ordering information

Sales structure

TC66-	Omnigrad S TC66. ATEX EEx d certified. Thermocouple thermometer complete of the thermowell from bar stock. Replaceable mineral inset: gounded or ungrounded. Terminal head connection with epoxy coating, IP66-IP68 Two operating and measurement ranges: from -40 to 750°C (with TC J); -40 to 1200°C (with TC K)			
	Approval:			
	A	Non-harzarus area		
	E	*ATEX II 2 GD EEx d IIC		
	M	*ATEX II 1/2 GD EEx d IIC		
	Head, material, IP grade			
	A	TA21H Alu. epoxy coating, , IP66 /IP68		
	Y	Special version, to be specified		
	Cable entry			
	A	1 x 1/2 NPT		
	B	2 x 1/2 NPT		
	C	1 x 3/4 NPT		
	D	2 x 3/4 NPT		
	E	1 x M20 x1,5		
	F	2 x M20 x1,5		
	Y	Special version, to be specified		
	Neck length N; Material; Fitting			
	B	69 mm, SS 316, N, 1/2"NPT M		
	C	109 mm, SS 316, N, 1/2"NPT M		
	E	148 mm, SS 316, NUN, 1/2"NPT M		
	F	69 mm, A105, N, 1/2"NPT M		
	G	109 mm, A 105, N, 1/2"NPT M		
	J	148 mm, A 105, NUN, 1/2"NPT M		
	Y	Special version, to be specified		
	Thermowell material:			
	B	SS 316Ti		
	C	SS 316		
	D	SS 316L		
	Y	Special version, to be specified		
	Extension T; D1; Df; Q1; Q2			
	1	70 mm, 30 mm, 7 mm, 20 mm, 14 mm,		
	2	75 mm, 35 mm, 7 mm, 24 mm, 14 mm,		
	6	100 mm, 35 mm, 7 mm, 25 mm, 18 mm,		
	9	Special version, to be specified		
	Insertion Length IL:			
	X	mm		
	Y	Special version, to be specified		
	Process connection:			
	11	thread 1/2" NPT - M		
	22	thread 3/4" NPT - M		
	CA	1" ANSI 150 RF SO, A105		
	CB	1" ANSI 150 RF SO, SS 316		
	CC	1" ANSI 300 RF SO, A105		
	CD	1" ANSI 300 RF SO, SS 316		
	CE	1" ANSI 600 RF SO, A105		
	CF	1" ANSI 600 RF SO, SS 316		
	CG	1"1/2 ANSI 150 RF SO, A105		
	CH	1" 1/2 ANSI 150 RF SO, SS 316		
	CI	1" 1/2 ANSI 300 RF SO, A105		
	CK	1" 1/2 ANSI 300 RF SO, SS 316		
	CL	1" 1/2 ANSI 600 RF SO, A105		
	CM	1" 1/2 ANSI 600 RF SO, SS 316		
	CQ	2" ANSI 300 RF SO, A105		
	CS	2" ANSI 600 RF SO, A105		

Supplementary documentation

<input type="checkbox"/> Brochure Field of activities - Temperature measurement	FA006T/09/en
<input type="checkbox"/> Temperature head transmitter iTEMP® PCP TMT181	TI070R/09/en
<input type="checkbox"/> Temperature head transmitter iTEMP® HART® TMT182	TI078R/09/en
<input type="checkbox"/> Temperature head transmitter iTEMP® PA TMT184	TI079R/09/en
<input type="checkbox"/> Industrial thermometers, RTD and Thermocouples	TI236T/02/en
<input type="checkbox"/> TC insert for temperature sensors - Omniset TPC100	TI278T/02/en
<input type="checkbox"/> TC insert for temperature sensors - Omniset TPC300 (to be released)	TI291T/02/en
<input type="checkbox"/> Safety instructions for use in hazardous areas (TPC300, to be released)	XA017T/02/en
<input type="checkbox"/> TC thermometers Omnigrad TSC - General information	TI090T/02/en

International Head Quarter

Endress+Hauser
GmbH+Co. KG
Instruments International
Colmarer Str. 6
79576 Weil am Rhein
Germany

Tel. +49 76 21 9 75 02
Fax +49 76 21 9 75 34 5
www.endress.com
info@ii.endress.com

Endress+Hauser 

People for Process Automation