

# Rosemount™ 936

## Toxic Open Path Gas Detector



## Legal notice

The Rosemount system described in this document is the property of Emerson.

No part of the hardware, software, or documentation may be reproduced, transmitted, transcribed, stored in a retrieval system, or translated into any language or computer language in any form or by any means without prior written permission of Emerson.

While great efforts have been made to ensure the accuracy and clarity of this document, Emerson assumes no responsibility resulting from any omissions in this document or from misuse of the information obtained herein. The information in this document has been carefully checked and is believed to be entirely reliable with all the necessary information included. Emerson does not assume any liability arising out of the application or any use of any product or circuit described herein; neither does it convey license under its patent rights or the rights of others.

### **⚠ WARNING**

All individuals who have or will have responsibility for using, maintaining, or servicing the product must read this manual thoroughly.

### **⚠ WARNING**

#### **Physical access**

Unauthorized personnel may potentially cause significant damage to and/or misconfiguration of end users' equipment. This could be intentional or unintentional and needs to be protected against.

Physical security is an important part of any security program and fundamental to protecting your system. Restrict physical access by unauthorized personnel to protect end users' assets. This is true for all systems used within the facility.

### **⚠ CAUTION**

The source and detector are not field-repairable due to the meticulous alignment and calibration of the sensors and the respective circuits.

Do not attempt to modify or repair the internal circuits or change their settings, as this will impair the system's performance and void the Emerson product warranty.

## Glossary and abbreviations

Abbreviation	Meaning
Analog video	Video values are represented by a scaled signal.
ATEX	Atmosphere explosives
AWG	American wire gauge
BIT	Built-in test
CMOS	Complementary metal oxide semiconductor image sensor
Digital video	Each component is represented by a number representing a discrete quantization.
DSP	Digital signal processing
EMC	Electromagnetic compatibility
EMI	Electromagnetic interference
HART®	Highway addressable remote transducer communication protocol
IAD	Immune at any distance
IECEX	International Electrochemical Commission explosion
IP	Internet protocol
IR3	Refers to the three infrared sensors

<b>Abbreviation</b>	<b>Meaning</b>
LED	Light-emitting diode
LNG	Liquified natural gas
mA	MilliAmps (0.001 amps)
Modbus®	Master-slave messaging structure
N/A	Not applicable
NPT	National pipe thread
NTSC	National Television System Committee (a color encoding system)
PAL	Phase alternation by line (a color encoding system)
PN	Part number
ppm	Concentration in parts per million. Defines the amount of gas molecule parts per million molecules of atmospheric
ppm.m	Integral of concentration in ppm units times the distance in meters.
RFI	Radio frequency interference
RTSP	Real time streaming protocol
SIL	Safety integrity level
UNC	Unified coarse thread
UV	Ultraviolet
Vac	Volts alternating current
Vdc	Volts direct current
μm	Micrometer



# Contents

<b>Chapter 1</b>	<b>Product overview.....</b>	<b>7</b>
<b>Chapter 2</b>	<b>Technical description.....</b>	<b>9</b>
	2.1 Features.....	9
	2.2 Applications.....	10
	2.3 Principle of operation.....	10
	2.4 Product certifications.....	12
	2.5 Models and types.....	14
	2.6 Ordering information.....	14
	2.7 Description.....	17
<b>Chapter 3</b>	<b>Operating modes.....</b>	<b>19</b>
	3.1 Operational modes.....	19
	3.2 Visual indicators.....	20
	3.3 Output signals.....	21
	3.4 System setup.....	22
<b>Chapter 4</b>	<b>Specifications.....</b>	<b>25</b>
	4.1 General specifications.....	25
	4.2 Electrical specifications.....	26
	4.3 Mechanical specifications.....	27
	4.4 Environmental specifications.....	28
<b>Chapter 5</b>	<b>Installation.....</b>	<b>31</b>
	5.1 Introduction.....	31
	5.2 General considerations.....	31
	5.3 Preparations for installation.....	34
	5.4 Certification instructions.....	35
	5.5 Install conduits and cables.....	40
	5.6 Mount detector and source to tilt mount.....	41
	5.7 Install detector wiring.....	44
	5.8 Wiring to detector terminals.....	45
	5.9 Wiring to ultraviolet (UV) source.....	45
	5.10 Align detector.....	47
<b>Chapter 6</b>	<b>Operation.....</b>	<b>51</b>
	6.1 Operating the open path system.....	51
	6.2 Safety precautions.....	51
	6.3 Power up.....	51
	6.4 Verifying signal.....	52
	6.5 Zero calibrate.....	54

	6.6 Functional check.....	57
<b>Chapter 7</b>	<b>Maintenance.....</b>	<b>59</b>
	7.1 General maintenance.....	59
	7.2 Periodic maintenance.....	59
<b>Chapter 8</b>	<b>Troubleshooting.....</b>	<b>61</b>
	8.1 Maintenance call.....	61
	8.2 NQ Ratio below the permitted limit.....	61
	8.3 NQ Ratio above the permitted limit.....	62
	8.4 Ratio out of the limit.....	62
	8.5 Voltage less than 16 Vdc.....	62
<b>Appendix A</b>	<b>Wiring configurations.....</b>	<b>63</b>
	A.1 RS-485 communication network.....	67
<b>Appendix B</b>	<b>SIL-2 features.....</b>	<b>69</b>
	B.1 Safety relevant parameters.....	69
	B.2 General conditions for safe use.....	69
<b>Appendix C</b>	<b>Support.....</b>	<b>71</b>
	C.1 Return of material.....	71
<b>Appendix D</b>	<b>Short range model.....</b>	<b>73</b>
<b>Appendix E</b>	<b>Declaration of Conformity.....</b>	<b>75</b>

# 1 Product overview

The Rosemount 936 Gas Detector employs an advanced xenon flash source and integrated electronics package, both housed in stainless steel housings to provide high quality and performance, fast response, and line of sight gas monitoring. The source/detector is backed by a three year warranty.

The detector is manufactured with heated optical windows to improve performance in icing, snow, and condensation conditions. The programmable functions are available through a HART® port used with an intrinsically safe (I.S.) handled unit.

The source and detector unit enclosures are ATEX and IECEx approved Exd flameproof with an integral segregated rear and an Exe terminal compartment to prevent exposing the sensors and electronics to the surrounding environment. The detector also has a plug interface for connection to a HART Field Communicator, which is intrinsically safe.

This Manual provides a full description of the detector and its features and contains instructions on installing, operating, and maintaining the detector.

The Rosemount 936 detects and monitors toxic gases, such as  $\text{NH}_3$  and  $\text{H}_2\text{S}$  at ppm.m concentrations in the air. The detector's response time is no more than ten seconds to T90.

The open path system uses an open path beam of flash light pulses that provide a long line of sight coverage equivalent to many point detectors along the path. The transmitter beam covers a UV spectrum from 200 nm to 300 nm. The detector continuously monitors for gas through the collimated beam over an optical path from 17 ft. (5 m) up to 200 ft. (60 m).





## 2 Technical description

### 2.1 Features

- Long range gas detection from 17 ft. (5 m) up to 200 ft. (60 m)
- High sensitivity and fast response to toxic gases
- Heated optics to improve performance in icing, condensation, and snow conditions
- Continuous operation in extreme and harsh environmental conditions
- Solar blind and immune to industrial environments
- Withstands extreme vibration conditions
- Standard 0-20 mA output
- Maintenance call (3 mA)
- HART® protocol: communication protocol
- RS-485 output Modbus®-compatible for personal computer (PC) communication network for a maximum of 247 systems
- Simple one person installation, alignment, and calibration
- ATEX and IECEx per
  - Ex II 2(2) G D
  - Ex db eb ib [ib Gb] IIB + H<sub>2</sub> T4 Gb
  - Ex tb [ib Db] IIIC T135 °C Db
  - T<sub>a</sub> = -55 °C to 65 °C
- TR CU approved per:
  - 1 Ex db eb ib [ib Gb] IIB + H<sub>2</sub> T4 Gb X
  - Ex tb IIIC T135 °C Db X
  - 55 °C ≤ T<sub>a</sub> ≤ 65 °C
- CSA C/US approved per:
  - Canada**
    - Ex db eb ib [ib Gb] IIB+H<sub>2</sub> T4 Gb
    - Ex tb [ib Db] IIIC T135 °C Db
    - T<sub>a</sub> = -55 °C to + 65 °C
  - USA**
    - Class I Zone 1 AEx db eb ib [ib Gb] IIB+H<sub>2</sub> T4 Gb
    - Zone 21 AEx tbm [ib Db] IIC T135 °C Db
    - T<sub>a</sub> = -55 °C to +65 °C
- TUV approved per SIL2 requirements.
- Inmetro (UL) approved.
- Programmable configuration via the Field Communicator

- Fast connections to intrinsically safe (I.S.) approved hand-held diagnostic/calibration unit
- Three-year warranty

## 2.2 Applications

You can use the Rosemount 936 system to monitor toxic gas concentrations in various applications, such as:

- Petrochemical, pharmaceutical, and other chemical storage and production areas
- Toxic chemical storage sites and hazardous waste disposal areas
- Detecting H<sub>2</sub>S in desulfurization processes at refineries, oil platforms, pipelines, refueling stations, and fuel storage facilities
- Transportation depots and shipping warehouses of degreasing and cleaning solvents
- Styrene monomer, polymers, and plastic industries
- NH<sub>3</sub> production facilities, storage, and transportation
- Air conditioning, refrigeration, and agriculture application areas for NH<sub>3</sub> and derivatives
- Semiconductor industry in which NH<sub>3</sub> concentration monitoring is required

## 2.3 Principle of operation

The system detects gases through dual-spectral range monitoring, analyzing the absorption of radiation caused by gases in the atmosphere and comparing it (ratio) to background atmospheric absorption.

### 2.3.1 Spectral fingerprint

Each hazardous material is detected at a specific wavelength selected according to its specific spectral absorption or **fingerprint**.

The detection process involves two separate sensors, one that absorbs a particular gas and one that is not sensitive to it.

### 2.3.2 Optical path

The Rosemount 936 detects the presence of toxic airborne vapors, gases, or aerosols in a monitored area when the defined substance crosses/enters the optical path between the radiation source unit and the detector.

Toxic gases/vapors present in the atmosphere cause absorption of the radiation pulse at specific wavelengths in the optical path between the radiating source and the detector. This causes a change in the signal intensity received by the detector, which is translated into an output related to the detector's measurement scale.

The system analyzes the defined open path at the spectral bands specific to the materials being monitored. The automatic gain control (AGC) unit compensates for environmental

disturbances, such as fog, rain, etc., through a constant comparison with its dual spectral beam.

### 2.3.3 Detected gases

The Rosemount 936 detects the following toxic gases and vapors according to their unique spectral absorption in the UV solar blind range:

#### **Ammonia (NH<sub>3</sub>)**

A flammable and toxic gas that is highly irritating and colorless with a pungent odor.

The early detection of NH<sub>3</sub> is essential to prevent its toxic effects, such as respiratory tract paralysis. In the ultraviolet (UV) band, NH<sub>3</sub> has a typical strong absorption in the solar blind range of 189 nm to 210 nm that enables its fast and reliable detection at low concentrations.

#### **Hydrogen sulfide (H<sub>2</sub>S)**

A flammable, poisonous gas with a characteristic smell of rotten eggs.

H<sub>2</sub>S is heavier than air and very dangerous to humans, causing collapse, coma, and death from respiratory failure within a few seconds of inhalation.

Early detection of H<sub>2</sub>S is essential to prevent its toxic influence.

In the UV band, H<sub>2</sub>S has characteristically strong absorption in the solar blind range of 189 nm to 270 nm, which enables fast and reliable detection at low concentrations.

### 2.3.4 Ultraviolet (UV) source

The Rosemount 936 employs the latest generation of Xenon UV flash bulbs to provide extended installation distance and maximum reliability.

### 2.3.5 Heated optics

The Rosemount 936 includes heated optics for the detector and source.

The heater increases the temperature of the optical surface by 5 to 8 °F (3 to 5 °C) above the ambient temperature to improve performance in icing, condensation, and snow conditions. Emerson has configured the heated optics to automatically operate when the change in temperature requires heating (default).

However, you can also define the heated optics as one of the following modes:

1. Not operated (not an option source unit)
2. On continuously
3. Automatic, per temperature change (default)

See [System setup](#).

When operated in Automatic mode, you can define the start temperature below which the window will be heated (default 41 °F [5 °C]). You can define this temperature between 32 °F (0 °C) and 122 °F (50 °C). The heating stops when the temperature is 27 °F (15 °C) above the start temperature.

## 2.3.6 HART<sup>®</sup> protocol

The Rosemount 936 uses the HART protocol.

This is a field communications protocol used to communicate between intelligent field instruments and the host system.

HART is the global standard for smart instrumentation, and most smart field devices installed in plants worldwide are HART-enabled. HART technology is easy to use and very reliable.

Through the HART connection, the detector can:

- Set up
- Troubleshoot
- Display health and status

You can connect the HART communication on the 0-20 mA line or through the intrinsically safe (I.S.) connection with a standard Field Communicator loaded with Emerson's host software and attached by a special harness.

## 2.3.7 Modbus<sup>®</sup> RS-485

For more advanced communications, the Rosemount 936 has an RS-485 Modbus-compatible output that provides data communication.

This feature enables simple commissioning, maintenance, and configuration.

## 2.3.8 Tilt mount

The stainless steel tilt mount provides a small installation footprint that can conform to limited space constraints, while the sturdy construction maintains alignment even in constant vibration.

The X and Y axis adjustments provide quick and easy alignment for installation and maintenance.

## 2.4 Product certifications

### 2.4.1 ATEX and IECEx

The Rosemount 936 is approved per:

Ex II 2(2) G D

Ex db eb ib [ib Gb] IIB+H<sub>2</sub> T4 Gb

Ex tb [ib Db] IIIC T135 °C Db

Ta = -55 °C to +65 °C

## 2.4.2 SIL-2

The Rosemount 936 is TUV approved for SIL-2 requirements per IEC61508.

The alert condition according to SIL-2 can be implemented by alert signal via 0-20 mA current loop.

## 2.4.3 TR CU

The Rosemount 936 is in compliance with the standard TR CU 012/2011 per:

1Ex db eb ib [ib Gb] IIB + H2 T4 Gb X

Ex tb IIIC T135 °C Db X

-55 °C ≤ Ta ≤ +65 °C

For more details, see TR CU Certificate number *TC RU C-US.M ю 62.B.05535*.

## 2.4.4 INMETRO

The Rosemount 936 is in compliance with the standards ABNT NBR IEC 60079-0, ABNT NBR IEC 60079-1, ABNT NBR IEC 60079-7, ABNT NBR IEC 60079-11, ABNT NBR IEC 60079-28, ABNT NBR IEC 60079-31, and INMETRO decree No. 179 as of May 18th, 2010.

Further details may be found on the Certificate of Compliance Number UL-BR 19.0726X.

## 2.4.5 CSA C/US

The Rosemount 936 is approved per CSA C/US for hazardous and ordinary locations:

### Canada

Ex db eb ib [ib Gb] IIB+H<sub>2</sub> T4 Gb

Ex tb [ib Db] IIIC T135 °C Db

T<sub>a</sub> = -55 °C to +65 °C

### USA

Class I Zone 1 AEx db eb ib [ib Gb] IIB+H<sub>2</sub> T4 Gb

Zone 21 AEx tb [ib Db] IIIC T135 °C Db

T<sub>a</sub> = -55 °C to +65 °C





The Rosemount 936 is a "Class 1 Laser Product" per IEC 60825-1: 2014 ed. 05.

## 2.5 Models and types

The Rosemount 936 is available as three transmitter models, determining the detection distance, with two possible detectors, detecting H<sub>2</sub>S or ammonia. This allows for detection at distances from 17 to 200 ft. (5 to 60 m).

Table 2-1 lists the various options.

**Table 2-1: Rosemount 936 source (transmitter) installation distances**

Model number	Source (transmitter) option code	Minimum installation distance	Maximum installation distance
936	T1	17 ft. (5 m)	52 ft. (16 m)
936	T2	46 ft. (14 m)	132 ft. (40 m)
936	T3	115 ft. (35 m)	200 ft. (60 m)

### Related information

[Short range model](#)

## 2.6 Ordering information

You can order the Rosemount 936 as separate parts: source (PN TXT00XXXX), detector (PN-RT12XXXXX), and commissioning kit.

### 2.6.1 Online product configurator

Many products are configurable online using our product configurator.

Visit our [website](#) to start. With this tool's built-in logic and continuous validation, you can configure your products more quickly and accurately.

### 2.6.2 Model codes

Model codes contain the details related to each product.

Exact model codes will vary; an example of a typical model code is shown in [Source \(Transmitter\)](#) and [Detector \(Receiver\)](#).

**Source (Transmitter)**

936T1T00F002SA1

**Detector (Receiver)**

936R1T262SA1

## 2.6.3 Specifications and options

See [Specifications](#) for more details on each configuration.

Specification and selection of product materials, options, or components must be made by the purchaser of the equipment.

## 2.6.4 Source (Transmitter)

### Required model components

#### Model

Code	Description
936	Toxic Open Path Gas Detector Source (Transmitter)

#### Transmitter range

Code	Description
T1	Transmitter - Range of 17 to 52 ft (5 to 16 m)
T2	Transmitter - Range of 46 to 132 ft (14 to 40 m)
T3	Transmitter - Range of 115 to 200 ft (35 to 60 m)

#### Gas calibration

Code	Description
T00	Transmitter

#### Housing style / conduit

Code	Material	Measurement
2S	Stainless steel	¾-in NPT
4S	Stainless steel	M25

#### Product certifications

Code	Description
A1	ATEX and IECEx

Code	Description
A3	CSA
E2	INMETRO
EM	CU TR (EAC)

## 2.6.5 Detector (Receiver)

### Required model components

#### Model

Code	Description
936	Toxic Open Path Gas Detector (Receiver)

#### Receiver selection

Code	Description
R1	Receiver

#### Gas calibration

Code	Description
T26	Hydrogen sulfide (receiver)
T27	Ammonia (receiver)

#### Housing style / conduit

Code	Material	Measurement
2S	Stainless steel	¾-in NPT
4S	Stainless steel	M25

#### Product certifications

Code	Description
A1	ATEX and IECEx
A3	CSA
E2	INMETRO
EM	CU TR (EAC)



## 2.7 Description

The Rosemount 936 comprises two main units:

- Ultraviolet source
- Detector

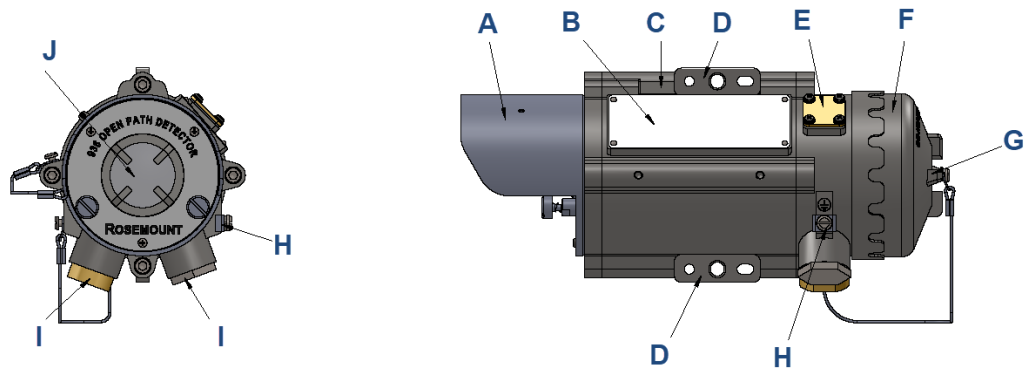
The Rosemount 936 detects gases over an open path transmitted from the source to the detector.

### 2.7.1 Ultraviolet (UV) source unit

The UV source unit emits radiation pulses at the rate of one pulse per second.

The pulse width (5 to 10  $\mu\text{sec}$ ) is very powerful. The front of the source unit has an internal reflector that collimates the UV beam for maximum intensity. The front window is heated to improve performance in icing, condensation, and snow conditions.

**Figure 2-1: UV Source**



- A. Weather shield
- B. Front window section
- C. Label
- D. Main housing
- E. Mounting plate
- F. Junction box
- G. Indicator light-emitting diode (LED)
- H. Earth terminal
- I. Cable inlet
- J. Front window

## 2.7.2 Detector unit

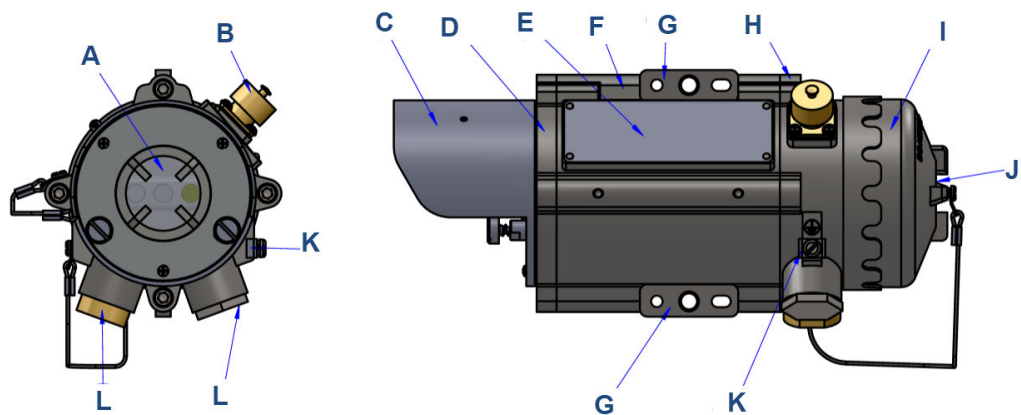
The detector receives the transmitted pulsed radiation signals from the source. The signals are then amplified and fed into an analog to digital signal converter to be processed by the internal microprocessor.

When the signals drop below a prescribed level, the internal microprocessor compensates for them. This allows the signals to be maintained even in severe weather conditions. The data is sent to the output interface section.

The front window of the detector is heated to improve performance in icing, condensation, and snow conditions.

There is one detector type that is suitable for the H<sub>2</sub>S version and one for the NH<sub>3</sub> version.

**Figure 2-2: Detector**



- A. Front window
- B. Handheld fast connection
- C. Weather shield
- D. Front window section
- E. Label
- F. Main housing
- G. Mounting plate
- H. Junction box
- I. Back cover
- J. Indicator light-emitting diode (LED)
- K. Earth terminal
- L. Cable inlet

## 3 Operating modes

### 3.1 Operational modes

The Rosemount 936 has four operational modes:

- Normal mode
- Maintenance call mode (3 mA output)
- Fault mode
- Zero calibration mode (1 mA output)

#### 3.1.1 Normal mode

This mode is used for gas detection. In Normal mode, the following statuses are possible:

- Normal (N): Signal received from gas detection is at safe levels.
- Warning (W): Gases have been detected at warning levels.
- Alarm (A): Gases have been detected at alarm levels.

#### NOTICE

For the standard 0-20 mA output, the warning and alarm levels are not relevant. Choose these alarm levels at the controller. The output detector is at 4 mA at zero reading and 20 mA for full-scale reading.

If using the RS-485 output, the detector changes its status from **N** to **W** at Warning level and to **A** at Alarm level.

#### 3.1.2 Maintenance call mode (3 mA output)

This mode indicates low signal that may be caused by a dirty window, misalignment, or poor source or if one of the detector's parameters is at the **limit** value.

The detector continues to function, but provides a (3 mA) pre-warning signal (via HART<sup>®</sup> and Modbus<sup>®</sup>) that a maintenance procedure is required.

#### 3.1.3 Fault mode

In the fault status, there are three fault types.

- Fault 1 (2 mA output) - non-critical  
If this occurs, it is due to blockage, very low signal, partial obscuration, or full beam block. In this situation, detection is no longer possible. The detector's proper operation can be restored (auto reset) during operation if the condition causing the problem is removed or resolved. This mode occurs after a delay of 60 seconds from the moment of the fault. This delay is important to eliminate momentary obscuration due to passing through the beam.

- Low voltage fault (1 mA output)  
In this situation, detection is disabled due to low voltage being supplied to the detector. The detector returns to proper operation only when proper voltage level is restored.
- Fault 2 (1 mA output)  
In this situation, the detection is disabled due to an electrical/software operational failure or a central device (memory or processor) fault. Such a fault causes the detector to cease operation. If there is a fault in the 0-20 mA loop, the output is 0 mA.

### 3.1.4 Zero calibration mode (1 mA output)

This mode zeroes the base level from which the detector reads gas.

Only do this when:

- No gases are present.
- There is a clear path between the source and the detector.
- Weather conditions are clear.

Use the Field Communicator or host software on your personal computer (PC) to zero calibrate after installation, re-alignment, and window cleaning. In parallel, while the detector is connected to the Field Communicator, the magnetic mode selector can be used for zero calibration.

#### Related information

[Zero calibrate](#)

## 3.2 Visual indicators

One three color light-emitting diode (LED) indicator is located in the back side of the detector/source and can be seen through the back cover window.

See [Figure 2-1](#) and [Figure 2-2](#).

The detector statuses are listed in [Table 3-1](#).

**Table 3-1: Detector LED indications**

Detector status	LED color	LED mode
Fault	Yellow	4 Hz - flashing
Alignment / Standby	Yellow	1 Hz - flashing
Zero calibration	Yellow	Constant
Normal	Green	1 Hz - flashing
Warning	Red	2 Hz - flashing
Alarm	Red	Constant

The source statuses are listed in [Table 3-2](#).

**Table 3-2: Source LED indications**

Source status	LED color	LED mode
Fault	Yellow	4 Hz - flashing
Normal	Green	1 Hz - flashing

## 3.3 Output signals

The Rosemount 936 system provides the following outputs:

- 0-20 mA current output
- RS-485 interface

### 3.3.1 0-20 mA current output

The 0-20 mA output provides the detector status measurements showing a continuous reading of exact gas concentration.

The 0-20 mA functions as current sink, but it can be reconfigured as source (see [Wiring configurations](#)).

The maximum permitted load resistance for the 0-20 mA output is 500 Ω.

**Table 3-3: Standard 0-20 mA Current for the Gas Channel**

Current reading	Status and description
0 mA + 0.2 mA	Fault in 0-20 mA loop
1 mA ± 0.2 mA	Zero calibration (in progress), fault 2
2 mA ± 0.2 mA	Fault 1 (non-critical)
3 mA ± 0.2 mA	Maintenance call
4 mA ± 0.2 mA	No gas present
4 mA - 20 mA	Continuous measuring of gas concentration at a range between 0 and 500 ppm.m or full scale
21 mA	Concentration is over the range limit (more than full-scale concentration).

### 3.3.2 RS-485 interface

The RS-485 input/output sends complete data information to a personal computer (PC) and receives data or control commands from the PC.

The protocol is Modbus<sup>®</sup>-compatible. The communication with the PC that is operated through the interface is executed only when used with appropriate host software.

## 3.4 System setup

### 3.4.1 Program detection functions

The Rosemount 936 incorporates several functions that can be set by the customer using:

- WinHost software
- HART® Field Communicator: The detector is equipped with an intrinsically safe connector to enable HART communication.

### 3.4.2 Set up detection function

See [Setting up detector defaults](#) for default settings.

#### Setting up addresses

The detector provides up to 247 address that can be used in the RS-485 communication link and up to 64 addresses that can be used in the HART® Field Communication link.

#### Heated optic operation

The heated optics for the detector unit can be defined as one of the following modes:

<b>Off</b>	Not operated
<b>On</b>	Operated continuously
<b>Auto</b>	On per temperature change (default)

When operated in Automatic mode, you can define the start temperature below which the window will be heated between 32 and 122 °F (0 and 50 °C). The detector stops heating the window when the temperature is 27 °F (15 °C) above the defined temperature.

This feature relates to the detector **only**.

The source heated optic must be defined within the model structure in two options:

- Heated continuously
- Start heating below 41 °F (5 °C)

#### Range

Select between short and mid/long range.

### 3.4.3 Setting up detector defaults

The detector has two functions which can be programmed according to the customer requirements at the factory or at the customer facility using a software host or a Field Communicator, available for download from the product web page.

Please contact Emerson for more information.

The standard setup is as follows:

**Table 3-4: Detector Default Setup**

<b>Function</b>	<b>Setup</b>
Heat mode	Auto
Heat on	41 °F (5 °C)

You can change the source defaults the same way.





# 4 Specifications

## 4.1 General specifications

### Detected gases

- Hydrogen sulfide (H<sub>2</sub>S)
- Ammonia (NH<sub>3</sub>)

**Table 4-1: Detection Distance Range**

Detector	Source	Minimum installation distance	Maximum installation distance
<b>H<sub>2</sub>S</b>			
RT126XXXX	T1T00XXXX	17 ft. (5 m)	52 ft. (16 m)
RT126XXXX	T2T00XXXX	46 ft. (14 m)	132 ft. (40 m)
RT126XXXX	T3T00XXXX	115 ft. (35 m)	200 ft. (60 m)
<b>NH<sub>3</sub></b>			
R1T127XXXX	T1T00XXXX	17 ft. (5 m)	52 ft. (16 m)
R1T127XXXX	T2T00XXXX	46 ft. (14 m)	132 ft. (40 m)
R1T127XXXX	T3T00XXXX	115 ft. (35 m)	200 ft. (60 m)

### Response time

< 3 sec, < 10 sec to T90

### Spectral response

200 to 300 nm

### Sensitivity range

Full scale	Warning	Alarm
500 ppm/m	100 ppm/m	300 ppm/m

### Field of view

Line of sight

### Alignment tolerance

±1 degree

### Minimum detectable gas volume

50 ppm/m

### Temperature range

-67 to 149 °F (-55 to 65 °C)

### Immunity to false alarm

Does not produce a false alarm and is not influenced by solar radiation, hydrocarbon flames, or other external infrared radiation sources.

## 4.2 Electrical specifications

### Operating voltage

18-32 Vdc

### Power consumption

**Table 4-2: Detector and Source Maximum Power Consumption**

	Without heated optic (max.)	With heated optic (max.)
Detector	150 mA	300 mA
Source	200 mA	300 mA

### Electrical input protection

The input circuit is protected against voltage-reversed polarity, voltage transients, surges, and spikes, according to EN50270.

### Electrical outputs

- 0-20 mA current output: The 0-20 mA is an isolated sink option. You can also configure this output as source (see [Wiring configurations](#)).  
The maximum permitted load resistance is 500 Ω.
- Communication network: The detector is equipped with an RS-485 communication link that can be used in installations with computerized controllers. Communication is compatible with the Modbus® protocol.
  - This protocol is standard and widely used.
  - It enables continuous communication between a single standard Modbus controller (master device) and a serial network of up to 247 detectors.
  - It enables connection between different types of Rosemount detectors or other Modbus devices to the same network.
- HART® protocol: A digital communication protocol used to communicate between intelligent field instruments and the host system. Through the HART protocol, the detector can:
  - Display setup.
  - Reconfigure setup.
  - Display and determine the detector status.
  - Perform detector diagnostics.

- Troubleshoot.

## 4.3 Mechanical specifications

### Enclosure

The detector, source, and tilt mount are stainless steel, 316 electro chemical, and passivized coating.

### Explosion proof

ATEX and IECEx

Ex II 2(2) G D

Ex db eb ib [ib Gb] IIB+H2 T4 Gb

Ex tb [ib Db] IIIC T135 °C Db

### Water and dust tight

IP66 and IP68

IP68 is rated for 7 ft. (2 m) depth for 45 minutes.

NEMA® 250 Type 6p

### Electrical modules

Conformal coated

### Electrical connection

Two options, specified at time of order:

- 2 x M25 (ISO)
- 2 x ¼-in.-14 national pipe thread (NPT) conduits

### Dimensions

- Detector: 10.5 x 5.1 x 5.1 in. (267 x 130 x 130 mm)
- Source: 10.5 x 5.1 x 5.1 in. (267 x 130 x 130 mm)
- Tilt mount: 4.7 x 4.7 x 5.5 in. (120 x 120 x 140 mm)

### Weight

Detector: 11 lb. (5 kg)

Source: 11 lb. (5 kg)

Tilt mount: 4.2 lb. (1.9 kg)

## 4.4 Environmental specifications

The Rosemount 936 system is designed to withstand harsh environmental conditions.

The source and detector units compensate for adverse conditions while maintaining accuracy.

### High temperature

The Rosemount 936 is designed to meet DNVGL-CG-0039, class D.

**Operating temperature** 149 °F (65 °C)

**Storage temperature** 149 °F (65 °C)

### Low temperature

The Rosemount 936 is designed to meet DNVGL-CG-0039, Class D.

**Operating temperature** -67 °F (-55 °C)

**Storage temperature** -67 °F (-55 °C)

### Humidity

The Rosemount 936 is designed to meet DNVGL-CG-0339, class B.

### Enclosure

The Rosemount 936 is designed to meet DNVGL-CG-0339, class C.

### Water and dust

- IP68 per EN60529
- IP66 per EN60529

**Dust** Completely protected against dust.

**Liquids** Protected against immersion between 5.9 in. (15 cm) and 3.3 ft. (1 m) in depth.  
Protected against water jets from all directions.

### Vibration

The Rosemount 936 is designed to meet DNVGL-CG-0339, class B.

### Electromagnetic compatibility (EMC)

This product is in conformance with EMC per EN50270.

**Radiated emission** EN55022

**Conducted emission** EN55022

**Radiated immunity** EN61000-4-3

**Conducted immunity** EN61000-4-6

**Electrostatic discharge (ESD)** EN61000-4-2

**Burst** EN61000-4-4

**Surge** EN61000-4-5

**Magnetic field** EN61000-4-8

To fully comply with EMC directive 2014/30/EU and protect against interference caused by radio frequency interference (RFI) and electromagnetic interference (EMI), the cable to the detector must be shielded, and the detector must be grounded. Ground the shield at the detector end.



# 5 Installation

## 5.1 Introduction

Use general purpose common tools and equipment to install and maintain the detector and source units.

Ensure that suitably qualified personnel install the equipment.

This section does not attempt to cover all of the standard practices and codes of installation. Rather, it emphasizes specific points of consideration and provides some general rules for suitably qualified personnel. It also stresses special safety precautions whenever applicable.

## 5.2 General considerations

### 5.2.1 Personnel

Only employ suitably qualified personnel who are familiar with the local codes and practices and trained for gas detection maintenance.

Ensure that wiring is only performed and supervised by someone with knowledge of electronics and, in particular, wiring installation.

### 5.2.2 Required tools

You can install the detector using general purpose common tools and equipment.

**Table 5-1: Tools**

Tool	Function
Alignment kit	Provides tools to install fine alignment tool.
Hex key 8 mm	Mounts the detector on the tilt mount.
Hex key 3/16 in.	Aligns the detector.
Hex key 5/16 in.	Screws 3/4 stop plug.
Flat screwdriver 4 mm	Connects ground terminal.
Flat screwdriver 2.5 mm	Connects wires to the terminal block.

### 5.2.3 Site requirements

When installing the Rosemount 936, take into account the weight of the monitored gas compared to that of the surrounding air and the individual site requirements.

Ensure that the site selected gives the detector a direct view to the source. The mounting point for each item should be secure and stable with minimal vibrations. Mount the equipment in a position where it cannot be knocked out of alignment and is guarded from physical impact.

### 5.2.4 Source and detector

Select the appropriate detector for the length of open path to be monitored.

To allow for aging of the source and a reduction of the ultraviolet (UV) signal due to adverse weather, Emerson recommends using a detector that is not at the limit of its operating range.

The general recommendation is to install the detector at a distance from the source of not more than 75 percent of the specified operating distance. In severe weather conditions, such as offshore oil production and exploration, reduce this distance to 50 percent.

Keep the path between the source and detector clear of any obstacles that might hinder the free movement of air in the protected area or block the UV beam.

### 5.2.5 Tips for gas detector locations

To provide the best detection coverage, install the detector:

- Below potential leak source for gases heavier than air.
- Above potential leak sources for gases lighter than air.
- Near to leak sources along the expected leak trajectory, taking into account prevailing wind directions.

#### **⚠ CAUTION**

For optimal performance, avoid placing the detector in locations frequently covered by steam.

### 5.2.6 Separation distances

To avoid cross talk between adjacent Open Path Gas Detector (OPGD) systems where transmitters are installed on the same side, keep the relevant separation distance between the neighboring OPGD systems according to the installation lengths as listed in [Table 5-2](#).

**Table 5-2: Minimum Separation Distances**

Installation line of sight distance, ft. (m)	Minimum separation, ft. (m)
33 (10)	3.3 (1)
66 (20)	5 (1.5)



**Table 5-2: Minimum Separation Distances (continued)**

Installation line of sight distance, ft. (m)	Minimum separation, ft. (m)
98 (30)	6.5 (2.5)
131 (40)	11.5 (3.5)
164 (50)	15 (4.5)
197 (60)	16.5 (5)

## 5.2.7 Wiring

For wiring, use color-coded conductors or suitable wire markings or labels.

- The wire cross-section must be between 28 to 14 AWG (0.5 mm<sup>2</sup> to 2.5 mm<sup>2</sup>).
- The selected wire gauge should be based on the number of detectors used on the same loop and the distance from the control unit. The maximum number of wire connections in one terminal is two wire cross-sections, each 1 mm<sup>2</sup>.
- To fully comply with electromagnetic compatibility (EMC) directive and protect against interference caused by radio frequency interference (RFI) and electromagnetic interference (EMI), the cable to the detector must be shielded, and the detector must be grounded. Ground the shield at the detector end.

## 5.3 Preparations for installation

Ensure that installation complies with local, national, and international regulations and norms as applicable to gas detectors and approved electrical devices installed in hazardous areas.

### 5.3.1 Equipment

The system should include the following (in addition to the Quick Start Guide):

**Figure 5-1: Box Contents**



Commissioning kit (not pictured)

- A. Source and detector
- B. Tilt mounts

- Detector unit: 936R1T2XXXX (see [Models and types](#))
- Source unit: 936TXT00XXXX (see [Models and types](#))
- Two tilt mount bases
  - One base is used for the detector.
  - One base is used for the ultraviolet (UV) source.

The commissioning kit (for H<sub>2</sub>S or NH<sub>3</sub>) includes:

- Magnetic mode selector
- Handle for cover opening
- Alignment tool kit
- Function check filter: for H<sub>2</sub>S or NH<sub>3</sub>

Other accessories are available, per customer request:

- Pole mount (U-bolt 5 in.)
- Pole mount (U-bolt 2-3 in.)
- RS-485 harness kit

- HART® hand-held harness kit
- Protective cover

See the *Rosemount 936 Product Data Sheet* for the accessory part numbers.

## 5.3.2 Unpacking

Upon receipt of your detector, check and record the following:

- Verify the appropriate purchase order. Record the part number and the serial number of the detectors and source units and the installation date in the appropriate log book.
- Open the container package immediately prior to detector installation and visually inspect the detectors, sources, and accessories.
- Verify that all components required for detector installation are readily available before commencing the installation. If you don't finish installing in a single session, secure and seal detectors and conduits.

## 5.4 Certification instructions

### ⚠ WARNING

Do not open the detector, even when isolated, in a flammable atmosphere.

### ⚠ WARNING

The cable entry point may exceed 182 °F (83 °C).

Take suitable precautions when selecting the cable.

- Only suitably certified cable entry devices or conduit shall be used for connections, and unused openings shall be blanked off using suitably certified stopping plugs.
- The marking of the equipment is:  
Ex II 2(2) G D  
Ex db eb ib [ib Gb] IIB+H2 T4 Gb  
Ex tb IIIC T135 °C Db
- The equipment may be used with flammable gases and vapors with apparatus groups IIA and IIB + H2 T4 in the ambient temperature range: -67 to 149 °F (-55 to 65 °C).
- Installation shall be carried out by suitably trained personnel in accordance with the applicable code of practice, e.g., EN60079-14:1997.
- Connections to the intrinsically safe (I.S.) port on the side of the detector enclosure should be made using equipment that maintains the intrinsically safe levels of protection.
- Inspection and maintenance of this equipment shall be carried out by suitably trained personnel in accordance with the applicable code of practice, e.g., EN 60079-19.

- The certification of this equipment relies upon the following materials used in its construction:
  - Enclosure: 316L stainless steel
  - Windows: sapphire glass
  - Seals: EPDM
- If the equipment is likely to come into contact with aggressive substances, then it is the operator's responsibility to take suitable precautions to prevent it from being adversely affected, thus ensuring that the type of protection provided by the equipment is not compromised.
  - Aggressive substances: For example, acidic liquids or gases that may attack metal or solvents that may affect polymeric materials.
  - Suitable precautions: For example, regular checks as part of routine inspections or establishing from the material's data sheets that it is resistant to specific chemicals.
- The output of the optical radiation source with respect to explosion protection meets Exception 3 from the scope of UL 60079-28.

## 5.4.1 Intrinsically safe (I.S.) outputs

Intrinsically safe outputs through the I.S. ports have the following parameters:

Parameter	Channels						
	Light-emitting diode (LED) 1	LED 2	HART® connection	RS485+	RS485-	5 V	All combined
Uo	6.51 V	6.51 V	6.51 V	6.51 V	6.51 V	6.51 V	6.51 V
Io	68.5 mA	68.5 mA	68.5 mA	68.5 mA	68.5 mA	68.5 mA	689.5 mA
Po	111.5 mW	111.5 mW	111.5 mW	111.5 mW	111.5 mW	111.5 mW	111.5 mW
Ci	0 μF	0 μF	0 μF	0 μF	0 μF	0 μF	0 μF
Li	0 μH	0 μH	0 μH	0 μH	0 μH	0 μH	0 μH
Co	22 μF	22 μF	22 μF	22 μF	22 μF	22 μF	22 μF
Lo	7.5 mH	7.5 mH	7.5 mH	7.5 mH	7.5 mH	514 μH	96.9 μH

### Note

Co @ 6.6 V is 22 μF, as per Table A.2 of IEC 60079-11:2011. Lo is calculated based on 1.5 times current for IIC, 40 μJ using  $E = 0.5 \cdot (LI)^2$

## 5.4.2 Special conditions for safe use from ATEX IECEx certificate

The dimensions of the flameproof joints differ from the relevant minimum or maximum values required by Table 2 of IEC/EN 60079-1: 2007 for IIB + H<sub>2</sub>, as detailed in [Table 5-3](#).

**Table 5-3: Flamepaths**

Flamepath description	Type of joint	Minimum width "L" in inches (millimeters)	Maximum gap "i <sub>c</sub> " in inches (millimeters)
Cylindrical section of spigot (both ends of Ex d compartment)	Cylindrical	0.59 (15)	0.003 (0.08)
1.2-in. (30 mm) diameter window fitted against enclosure	Flanged	0.42 (10.7)	0.001 (0.02)
1.6-in. (39.5 mm) diameter window fitted against enclosure	Flanged	0.39 (10)	0.001 (0.02)

- Gaps, "i<sub>c</sub>", should not be modified to be any larger, and widths, "L", should not be modified to be any shorter than the values in [Table 5-3](#).
- Connections to the intrinsically safe (I.S.) port on the side of the detector enclosure should be made using equipment that maintains the intrinsically safe levels of protection.
- The Um should be installed in accordance with one of the following:
  - The Um is 18 to 32 Vdc in a SELV/PELV system.
  - Via a safety isolating transformer, complying with the requirements of IEC 61588-2-6 or technically equivalent standard.
  - Directly connected to apparatus, complying with IEC 60950, IEC 61010-1, or technically equivalent standard.
  - Fed directly from cells or batteries.
- If the product is to be used as a safety related device, an appropriate independent certification, would be required meeting all the requirements.

## 5.4.3 North American conditions of acceptability from certificate CSA 80023016

### Conditions for Canadian installations

1. The dimensions of the flameproof joints are other than the relevant minimum or maximum values required by Table 2 of CAN/CSA-C22.2 No. 60079-0:19 Ed. 4 for IIB + H<sub>2</sub>, as detailed below:

Flamepath description	Type of joint	Minimum width "L" (mm)	Maximum gap "ic" (mm)
Cylindrical section of spigot (both ends of Ex d compartment)	Cylindrical	15	0.08
30 mm diameter window fitted against enclosure	Flanged	10.7	0.02
39.5 mm diameter window fitted against enclosure	Flanged	10	0.02

Gaps shall not be machined to be any larger than the values of "ic", and widths shall not be modified to be any smaller than the values of "L" shown in the table above.

2. Connections to the intrinsically safe (I.S.) port on the side of the detector enclosure shall be made via equipment which maintains the intrinsically safe levels of protection.
3. Where  $U_m$  marked on the associated apparatus is less than 250 V, it shall be installed in accordance with one of the following:
  - Where  $U_m$  does not exceed 50 Vac or 120 Vdc, in a SELV or PELV system or
  - Via a safety isolating transformer complying with the requirements of CAN/CSA-C22.2 No. 66.1 or technically equivalent standard or
  - Directly connected to apparatus complying with CAN/CSA-C22.2 No. 60950-1, CAN/CSA-C22.2 No. 61010-1 or technically equivalent standard or
  - Fed directly from cells or batteries.
4. The output of the optical radiation source with respect to explosion protection meets Exception 3 from the scope of CAN/CSA-C22.2 No. 60079-28:16 Ed.1.
5. Upon installation, remove the plastic transit plug from the cable entry and use a cable fitting or a conduit fitting with the following specification to connect the cable to the equipment:
  - Ex marking: Ex eb IIC Gb, Ex tb IIIC Db
  - Temperature rating: -55 °C to +83 °C or better
  - Connecting thread: M25 x 1.5 or ¾-in. national pipe thread (NPT)
6. Equipment is only to be installed by manufacturer trained personnel.
7. Equipment has only been tested for electrical safety. No evaluation of functional safety and performance characteristics has been conducted.
8. The equipment shall be supplied with Limited Energy Circuit (LEC) as defined in CSA C22.2 No. 61010-1-12 or Limited Power Source (LPS) as defined in CAN/CSA C22.2 No. 60950-1.

## Conditions for US installations

- The dimensions of the flameproof joints are other than the relevant minimum or maximum values required by Table 2 of UL 60079-0:2019 Ed. 7 for IIB + H2, as detailed below:

Flamepath description	Type of joint	Minimum width "L" (mm)	Maximum gap "ic" (mm)
Cylindrical section of spigot (both ends of Ex d compartment)	Cylindrical	15	0.08
30 mm diameter window fitted against enclosure	Flanged	10.7	0.02
39.5 mm diameter window fitted against enclosure	Flanged	10	0.02

Gaps shall not be machined to be any larger than the values of "ic", and widths shall not be modified to be any smaller than the values of "L" shown in the table above.

- Connections to the intrinsically safe (I.S.) port on the side of the detector enclosure shall be made via equipment which maintains the intrinsically safe levels of protection.
- Where  $U_m$  marked on the associated apparatus is less than 250 V, it shall be installed in accordance with one of the following:
  - Where  $U_m$  does not exceed 50 Vac or 120 Vdc, in a SELV or PELV system or
  - Via a safety isolating transformer complying with the requirements of UL 5085-1 or technically equivalent standard or
  - Directly connected to apparatus complying with UL 60950-1, UL 61010-1, or technically equivalent standard or
  - Fed directly from cells or batteries.
- The output of the optical radiation source with respect to explosion protection meets Exception 3 from the scope of UL 60079-28:2017 Ed. 2.
- Upon installation, remove the plastic transit plug from the cable entry and use a cable fitting or a conduit fitting with the following specification to connect the cable to the equipment:
  - Ex marking: Class I Zone 1 AEx eb IIC Gb, Zone 21 AEx tb IIIC Db
  - Temperature rating: -55 °C to +83 °C or better
  - Connecting thread: M25 x 1.5 or ¾-in. national pipe thread (NPT)
- Equipment is only to be installed by manufacturer trained personnel.
- Equipment has only been tested for electrical safety. No evaluation of functional safety and performance characteristics has been conducted.

8. The equipment shall be supplied with Class 2 as defined in article 725.121 or NFPA 70.

## 5.5 Install conduits and cables

The conduit and cable installation must comply with the following guidelines:

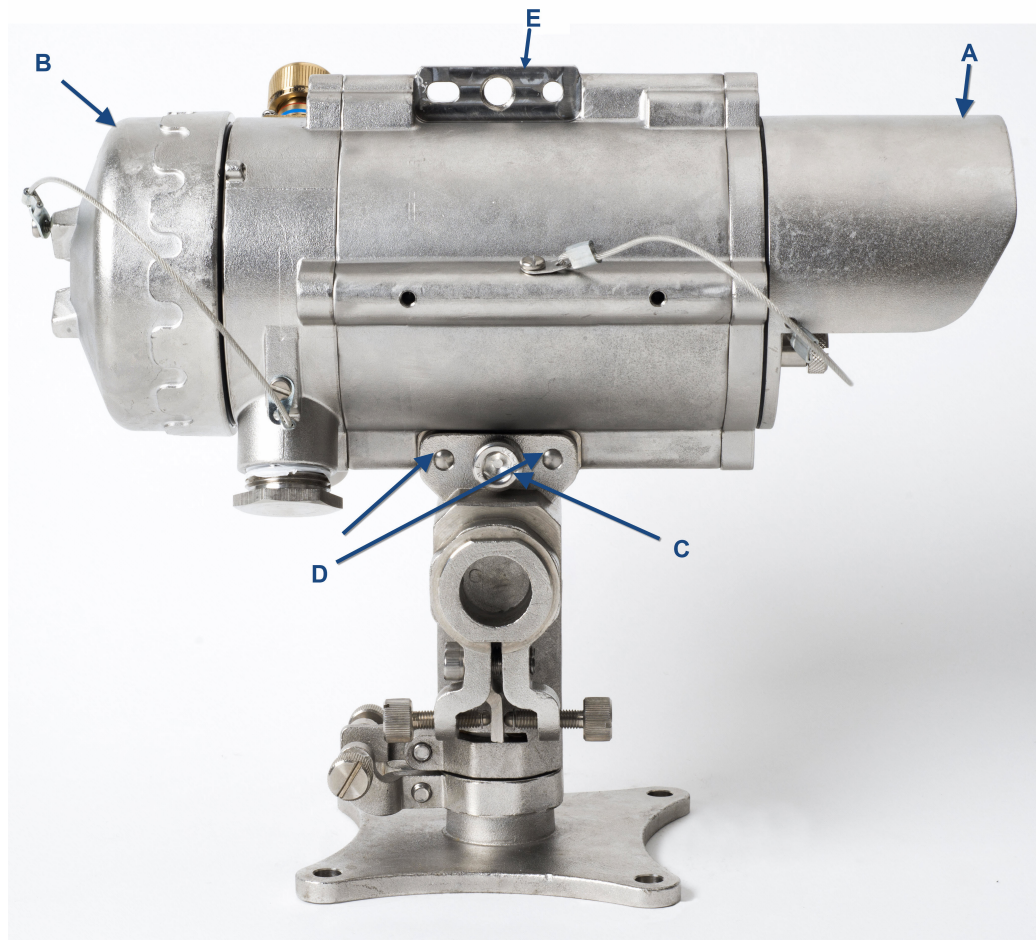
- To avoid water condensation in the detector, install it with the conduits/cable entries facing downwards.
- Use flexible conduits/cables for the last portion connecting to the detector.
- When pulling the cables through the conduits, ensure that they are not tangled or stressed. Extend the cables about 12-in. (30 cm) beyond the detector location to accommodate wiring after installation.
- After pulling the conductor cables through the conduits, perform a continuity test.



## 5.6 Mount detector and source to tilt mount

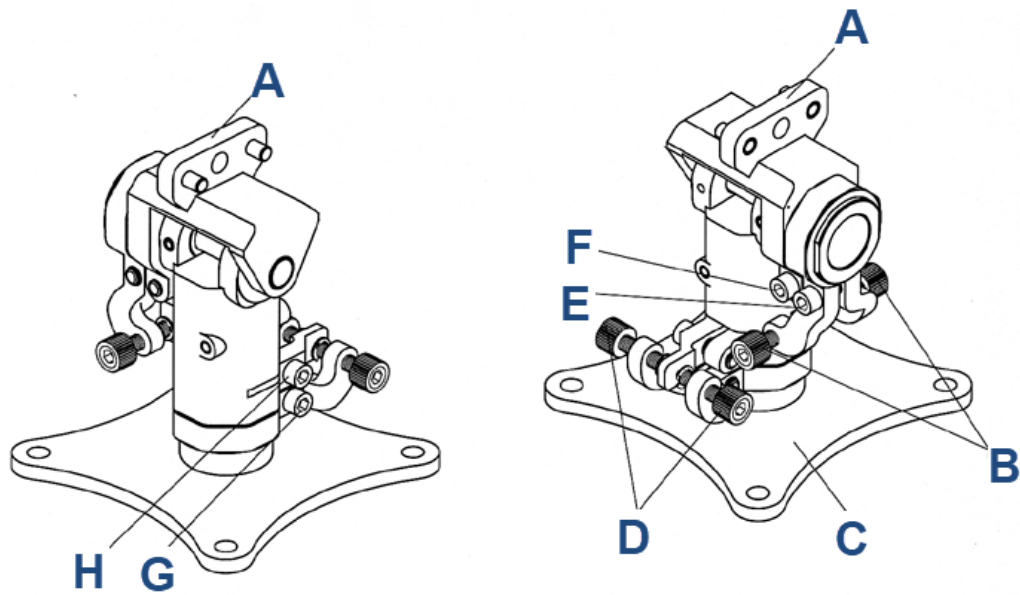
You can install the detector and source in two ways with the same tilt mount by using the upper or lower mounting access.

**Figure 5-2: Mounting the Tilt Mount and Detector Using the Lower Mounting Access**



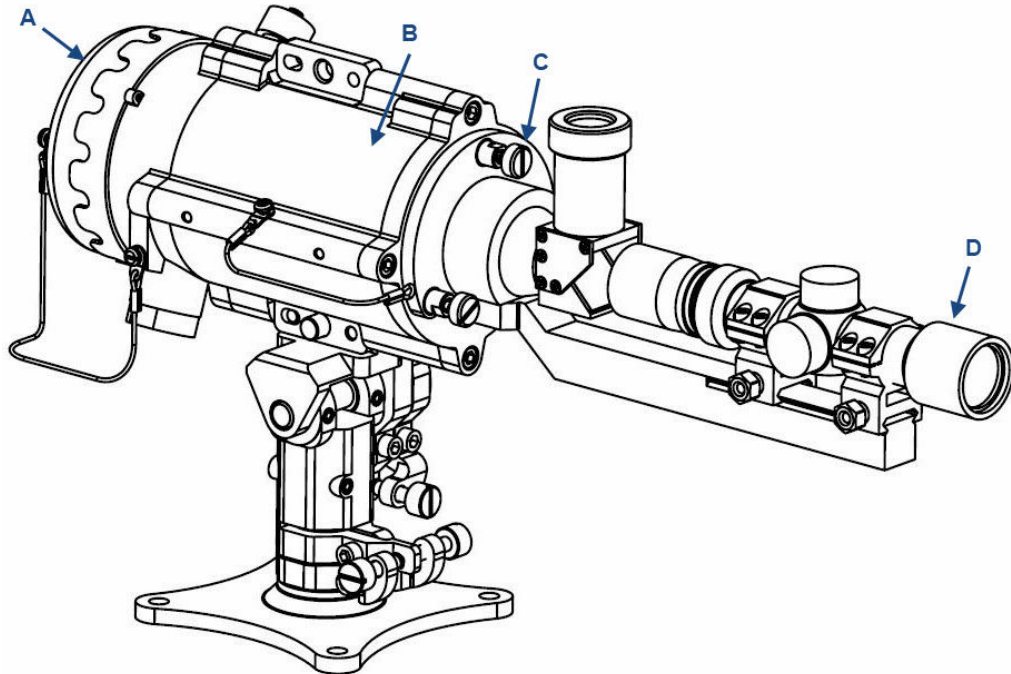
- A. Front shield
- B. Back cover
- C. Security screw
- D. Locating pins
- E. Alternate mounting location

**Figure 5-3: Tilt Mount**



- A. Detector/source holding plate
- B. Vertical fine alignment screw
- C. Tilt mount holding plate
- D. Horizontal fine alignment screw
- E. Vertical crude alignment tightening screw
- F. Vertical fine alignment tightening screw
- G. Horizontal crude alignment tightening screw
- H. Horizontal fine alignment tightening screw

**Figure 5-4: Detector and Tilt Mount Assembly Using Lower Mounting Access**



- A. Back cover
- B. Detector
- C. Alignment tool tightening bolt
- D. Alignment tool

**Table 5-4: Tilt Mount Kit**

Item	Quantity	Type / model
Tilt mount	1	N/A
Screw	1	M10 x 1.5
Spring washer	1	No. 10

**Prerequisites**

Prior to mounting the tilt mount to a stable surface, verify that the line of site is unobstructed and corresponds to the detector's installation distance.

**Procedure**

1. Place the tilt mount holding plate in its designated location and secure it with four fasteners through four holes with diameters of 0.3-in. (8.5 mm).

**NOTICE**

Skip this step if the tilt mount is already installed.

Removing the detector for maintenance purposes does not require removing the tilt mount.

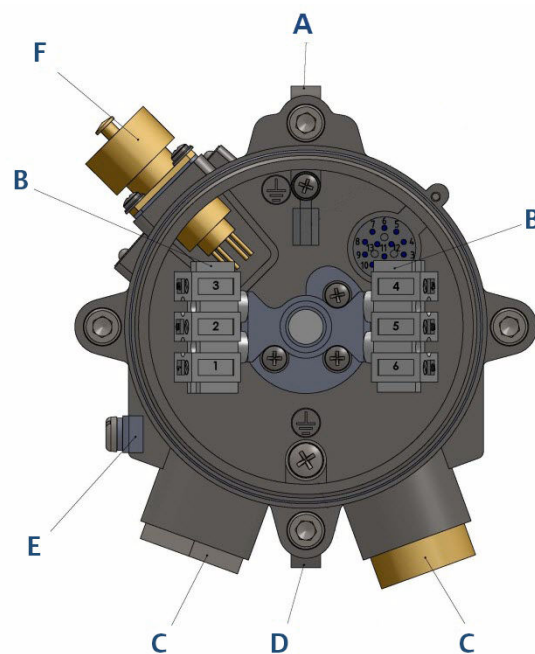
2. Place the detector with its conduit/cable inlets pointing downwards on the detector holding plate of the tilt mount.
3. Secure the detector with M10 x 1.5 screws with number M10 spring washers.
4. Secure the detector to the tilt mount using hex key number 7 for M10 x 1.5 screws.
5. Repeat steps [Step 1](#) through [Step 4](#) to install the source.

## 5.7 Install detector wiring

### Procedure

1. Release the back cover secure bolt and open the detector back cover. The chamber is now revealed.

**Figure 5-5: Detector with Cover Removed**



- A. Housing
- B. Terminal board
- C. Inlet conduit
- D. Detector holding plate
- E. Earth terminal
- F. Connection to Field Communicator

2. Remove the protective plug mounted on the detector conduit/cable entry inlet.
3. Pull the wires through the detector inlet conduit.

4. Use a 3/4-in. - 14 national pipe thread (NPT) or M25 x 1.5 conduit connection/cable gland to assemble the cable conduit to the detector.
5. Connect the wires to the required terminals according to the wiring diagram. See [Wiring to detector terminals](#) and [Wiring configurations](#).
6. Connect the grounding wire to the ground screw outside the detector. The detector must be well grounded to earth ground.
7. Place and secure the detector cover by screwing the cover and securing it using the secure bolt.

## 5.8 Wiring to detector terminals

The detector has six wiring terminals. [Table 5-5](#) describes the function of each electrical terminal of the detector.

**Table 5-5: Wiring Options**

Terminal number	Function
1	Power +24 Vdc
2	Return -24 Vdc
3	0-20 mA (input)
4	0-20 mA (output)
5	RS-485 (+)
6	RS-485 (-)

## 5.9 Wiring to ultraviolet (UV) source

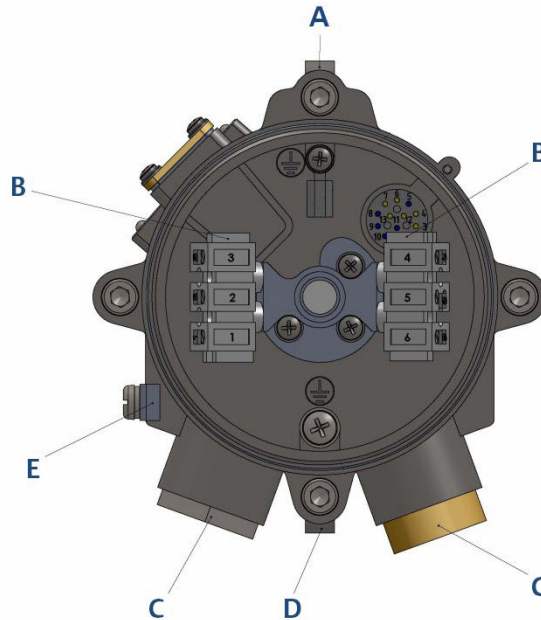
### 5.9.1 Install wiring to ultraviolet (UV) source

#### Procedure

1. Release the back screw bolt ([Figure 5-4](#)) and open the source back cover. The chamber is now exposed.

2. Remove the protective plug mounted on the source conduit/cable entry inlet and pull the wires through the source inlet (Figure 5-6). Use a 3/4-in. - 14 national pipe thread (NPT) or M25 x 1.5 conduit connection/cable gland to assemble the cable/explosion-proof conduit to the detector.

**Figure 5-6: Source with Cover Removed**



- A. Housing
- B. Terminal board
- C. Inlet conduit
- D. Detector holding plate
- E. Earth terminal

3. Connect the wires to the required terminals according to the wiring diagram. See [Wiring to source terminals](#).
4. Connect the grounding wire to the ground screw located on the exterior of the detector.  
Ensure that the source is well grounded to earth ground.

**Note**

In case of installation in the US, use the internal grounding connection for the equipment grounding connection and the external connection for a supplementary bonding connection where local codes or authorities permit or require such connection. The external bonding conductor is manufactured from copper and is 4 mm<sup>2</sup> in size. Use a tightening torque of 16 in.-lb. (1.8 Nm) to secure the bonding conductor.

5. Place and secure the source back cover by screwing on the cover and securing the back-screw bolt.

## 5.9.2 Wiring to source terminals

The source contains six wiring terminals.

**Table 5-6: Flash Source Wiring Options**

Terminal number	Function
1	Power + 24 Vdc
2	Return - 24 Vdc
3	Not used
4	Not used
5	RS-485 (+)
6	RS-485 (-)

## 5.10 Align detector

Use the alignment tool to align the detector.

Perform the alignment procedure in two stages:

- Crude alignment
- Fine alignment

The alignment tool includes a periscope, consisting of a prism and an ocular, located vertical to the alignment tool assembly. This allows you to look into the opposite detector perpendicularly to the alignment when you cannot access the detector's rear. If you can access the detector's rear, you do not need the periscope. In this case, remove it by releasing the periscope fastening screw.

### **⚠ CAUTION**

Changing factory calibration may prevent optimal alignment.

Before installing the alignment tool, verify that it and its sight mounting are free from any dirt to ensure proper alignment according to factory calibration.

Do not attempt to change any factory calibration at the alignment tool or its mounting.

To align the detector (see [Figure 5-3](#)):

1. Make sure that the detector and flash source are installed properly. [Installation](#) provides installation instructions.
2. Remove the front shield using the two captive screws.
3. Install the alignment tool ([Figure 5-4](#)) on the detector/source front.
4. Fasten the alignment tool with fastening screws.

## 5.10.1 Perform crude alignment

### Prerequisites

Use a ¼-in. Allen screwdriver for all alignment screws.

### Procedure

1. Loosen the horizontal lock screws.
2. Approximately aim the source horizontally towards the detector.
3. Tighten the horizontal lock screw adjacent to the plate.
4. Loosen the vertical lock screws.

### ⚠ CAUTION

If the detector is not properly supported when the lock screws are loosened, it could fall and get damaged.

Support the detector when loosening the vertical lock screws.

5. Approximately aim the source vertically towards the detector.
6. Tighten the outer vertical lock screw.
7. Repeat this process for the detector.

## 5.10.2 Perform fine alignment

Refer to [Figure 5-4](#) to see the detector with the alignment tool installed.

### Procedure

1. Remove the front shield and mount the alignment tool on the front of the source using the three screws.  
The alignment tool is supplied in the commissioning kit.
2. Aim the source towards the detector within the horizontal access.
3. Aim the alignment tool to the center of the front window of the detector or source.  
See [Figure 5-7](#).
4. Tighten the outer horizontal lock screw.
5. Aim the vertical axis.
6. Tighten the inner vertical lock screw.
7. Make sure the alignment tool cross is pointing to the detector and source center of the window.
8. Repeat [Step 2](#) through [Step 7](#) to align the detector.
9. Remove the alignment tool.
10. Install the front shield.



### Postrequisites

Once you have completed fine alignment for both the source and detector, you can turn on the power.

---

**Figure 5-7: View through the Alignment Tool**





## 6 Operation

### 6.1 Operating the open path system

Once you have positioned the system, it automatically monitors for possible specified gases and sends signals to a standard control panel or personal computer (PC). This chapter describes alignment, calibration, and operation.

---

**Important**

Accurate alignment is essential for proper operation of the Rosemount 936 system.

---

### 6.2 Safety precautions

After powering up, the detector requires minimal attention in order to function properly, but note the following:

**▲ WARNING**

Follow the instructions in this document; refer to the drawings and specifications issued by the manufacturer.

**▲ WARNING**

Do not open the detector/source housing while power is applied.

**▲ WARNING**

Disconnect external devices, such as automatic extinguishing systems, before carrying out any maintenance tasks.

### 6.3 Power up

**▲ WARNING**

Prior to operating or maintaining the detector, follow [Safety precautions](#).

**Procedure**

1. Ensure that the source and detector are connected to power.
2. Ensure that the 4-20 mA wiring meter is connected to the detector.
3. Power up the system 18 to 32 Vdc.

After sixty seconds, the current meter indicates 4 mA.

### Postrequisites

After powering up, zero calibrate the system. See [Zero calibrate](#).

## 6.4 Verifying signal

Use a Field Communicator to verify the signal.

The signal verification check determines the proper operation of the open path. It checks the alignment and cleanliness of the window and for any problems in the source or detector.

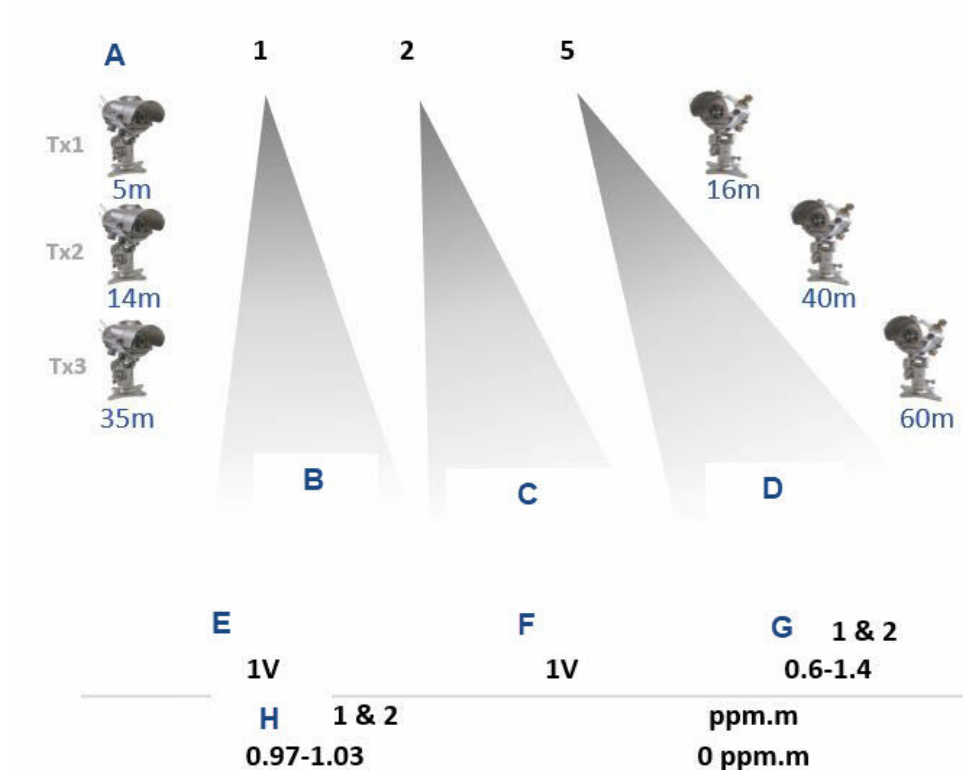
## 6.4.1 Signal limits

**Table 6-1: Maintenance Channels' Limits**

Channel	Short range <sup>(1)</sup>		Medium range <sup>(2)</sup>		Long range <sup>(3)</sup>
	17 ft. (5 m)	52 ft. (16 m)	46 ft. (14 m)	131 ft. (40 m)	197 ft. (60 m)
Reference	2 V gain 0	1.5 V gain 2	2 V gain 0	1 V gain 1	1 V gain 2
Signal 1 & 2	2 V gain 0	1.5 V gain 2	2 V gain 0	1 V gain 1	1 V gain 2
Ratio 1 & 2	0.6 to 1.4				
NQRat 1 & 2	0.97 to 1.03				
ppm.m	0 ppm.m				
Temperature	Up to 25 °C beyond ambient temperature				
Voltage	32 Vdc > V > 18 Vdc				

- (1) The minimum distance, as defined on the model number.  
 (2) Half the maximum distance, as defined on the model number.  
 (3) The maximum distance, as defined on the model number.

**Figure 6-1: Maintenance Channels' Limits**



- A. Maximum gain
- B. Minimum range
- C. Median range
- D. Maximum range
- E. Reference minimum
- F. Signal minimum
- G. Ratio
- H. NQ ratio

## 6.5 Zero calibrate

### Prerequisites

Zero calibrate after any of the following:

- Installation
- Realignment
- Window cleaning
- Any change in detector or source position

**⚠ WARNING**

Only zero calibrate when:

- No combustible gases are present.
- There is a clear path between the source and the detector.
- Weather conditions are clear.

Before zero calibrating, align the detector precisely.

**Figure 6-2: Screens shown when Zero Calibrating with WinHost® Software**

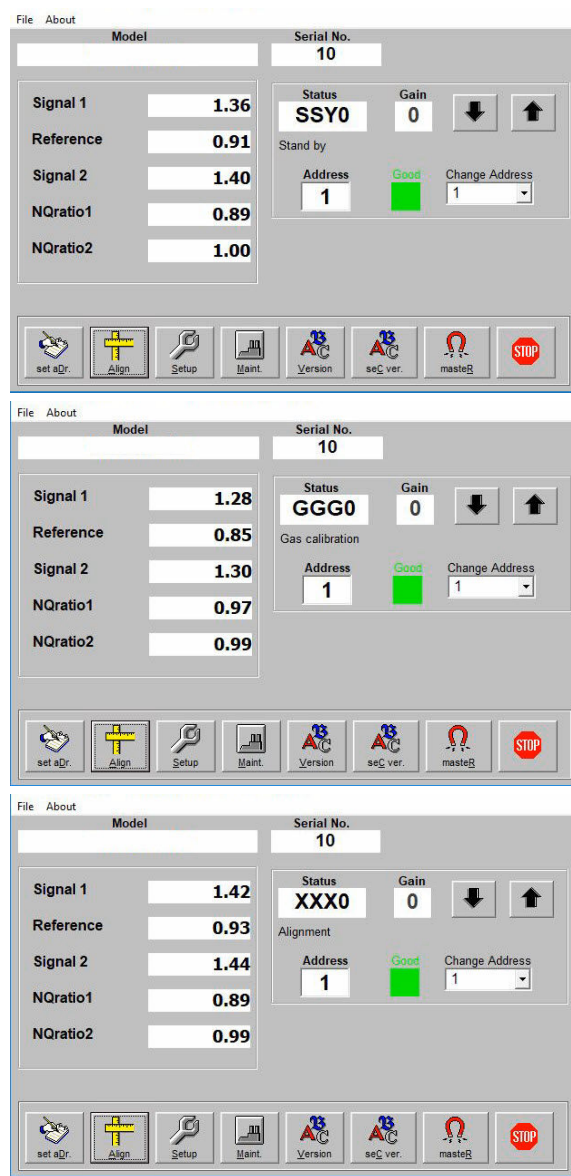
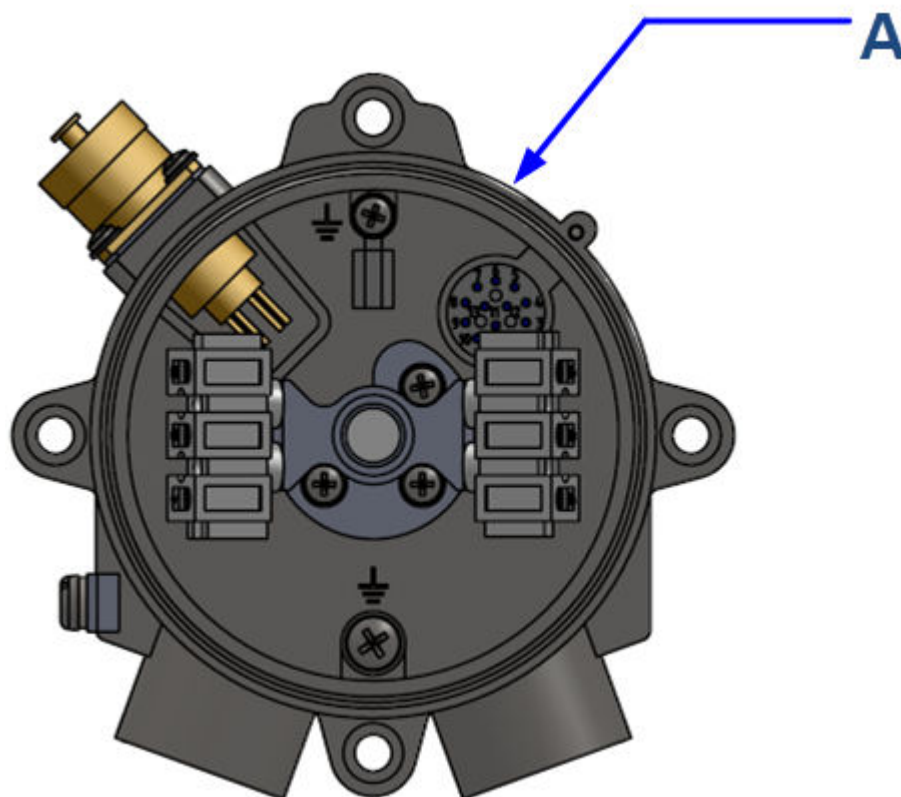


Figure 6-3: Magnetic Mode Selector



A. Magnet

To switch from each position (Step 1 through Step 3), use either Winhost, HART®, or RS-485 or move the magnetic mode selector above the magnetic switch (see Figure 6-3).

#### Procedure

1. Switch from Normal to Alignment mode.
2. Switch from Alignment to Standby mode.
3. Switch from Standby to Zero Calibration mode.  
The 0-20 mA output should now be at 1 mA.
4. Wait up to sixty seconds until it switches to Normal mode.  
The detector reading is now set to Normal. The 0-20 mA output should now indicate 4 mA.



## 6.6 Functional check

Emerson calibrated the Rosemount 936 system at the factory for your specific gas or vapor detection requirements. Use the check filters included in the commissioning kit according to the corresponding calibrating gas to validate correct installation.

The functional check filter is a convenient operational check used to confirm that the response has not changed from previous readings. The filter is not used for calibration, which is unnecessary, nor does it equate to a particular quantity of gas.

### Prerequisites

#### **⚠ WARNING**

Do not allow automatic activation.  
Disconnect any external device that should not be activated during the calibration check.

#### Note

This functional verification procedure is for a standard 0-20 mA output. Prior to starting the functional check, verify that the power to the detector is on and that the current of the 0-20 mA channel is stable. Record the reading.

#### Note

The R1T26xxx short range model detects Hydrogen Sulfide (H<sub>2</sub>S) gas at a distance of 17–52 ft. (5–16 m). Unless specified in your purchase order, the detecting unit is set by default to the mid/long range. To configure the model for short range detection, please refer to [Short range model](#).

### Procedure

1. Position the functional check filter in front of the detector. Center the functional check filter's window over the viewing window of the detector.  
The check filters are provided in the commissioning kit.

**Figure 6-4: Detector with Functional Check Filter Installed**



2. Wait twenty seconds.

3. Read the 0-20 mA current. Determine the difference between the reading taken with and without the functional check filter.  
The difference is the 0-20 mA current variance.
4. Record the 0-20 mA current variance in the maintenance log book.

**Postrequisites**

If the variance is more than a 30 percent change when compared to the previous check (see delivery form), repeat the alignment.

# 7 Maintenance

## 7.1 General maintenance

The source and detector viewing windows should be kept as clean as possible. The frequency of cleaning operations depends on the existing environmental conditions and the applications used.

## 7.2 Periodic maintenance

Emerson recommends keeping the source and detector viewing windows as clean as possible.

---

### Note

The frequency of cleaning operations is ultimately dependent upon the existing environmental conditions and the applications used.

---

Things to keep in mind when performing periodic maintenance:

- Proper maintenance will allow the system to retain maximum performance and reliability.
- Align the detector each time that the source or the detector has been opened or moved for any reason.
- The signal verification check corroborates the current signals from the flash source compared to that of previous alignments. Emerson recommends performing this check every six to twelve months. Check the signal according to threshold levels. See [Verifying signal](#).
- Zero calibrate (see [Zero calibrate](#)) every time the detector or source is realigned or the windows are cleaned.

### 7.2.1 Clean optical surfaces

The optical surfaces concerned are the source and detector viewing windows.

#### Procedure

1. Turn off the power to the detector and source.
2. In places where dust or dirt has accumulated on the optical surface, clean the surface with a small, soft bristle brush.
3. Wash the surfaces thoroughly with water and a mild non-abrasive detergent.
4. Thoroughly rinse the glass surface with clean water, ensuring that no residue is left behind.
5. Dry the glass with a clean, dry, soft cloth.
6. Enter the date and the names of the person and company who performed the maintenance service in the maintenance logbook.
7. Turn on power to the detector and source.

8. Verify the signal.  
See [Verifying signal](#).
9. Zero calibrate (see [Zero calibrate](#)).
10. Do a functional check (see [Functional check](#)).

## 8 Troubleshooting

### 8.1 Maintenance call

Status O/M/N: Signals are below 2.5 Vdc at gain 4.

Status R/M/N: Ratios are below 0.5.

**Table 8-1: Potential Causes and Resolutions**

Potential cause	Resolution
Poor alignment	Align.
Dirt on the window	Clean the window.
Poor light source	Replace the light source.
Detector fault	Replace or repair the detector.

### 8.2 NQ Ratio below the permitted limit

**Table 8-2: Potential Cause and Resolution**

Potential cause	Resolution
Gas in path	Ensure that the path is clean and the weather conditions are good.

## 8.3 NQ Ratio above the permitted limit

Host status = F

0-20 = 1 mA

Light-emitting diode (LED) = yellow, blinking

**Table 8-3: Potential Cause and Resolution**

Potential cause	Resolution
Poor alignment	Align.

## 8.4 Ratio out of the limit

Host status = F

0-20 = 1 mA

Light-emitting diode (LED) = yellow, blinking

**Table 8-4: Potential Causes and Resolutions**

Potential cause	Resolution
Poor alignment	Align.
Dirt on the window	Clean the window.
Detector fault	Replace or repair the detector.

## 8.5 Voltage less than 16 Vdc

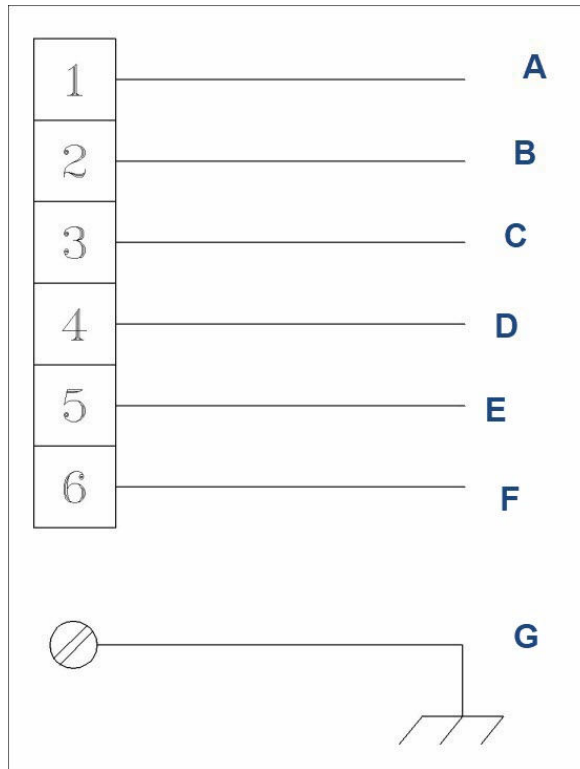
The detector is at V fault.

**Table 8-5: Potential Cause and Resolution**

Potential cause	Resolution
Low input voltage	Check the power supply and installation.

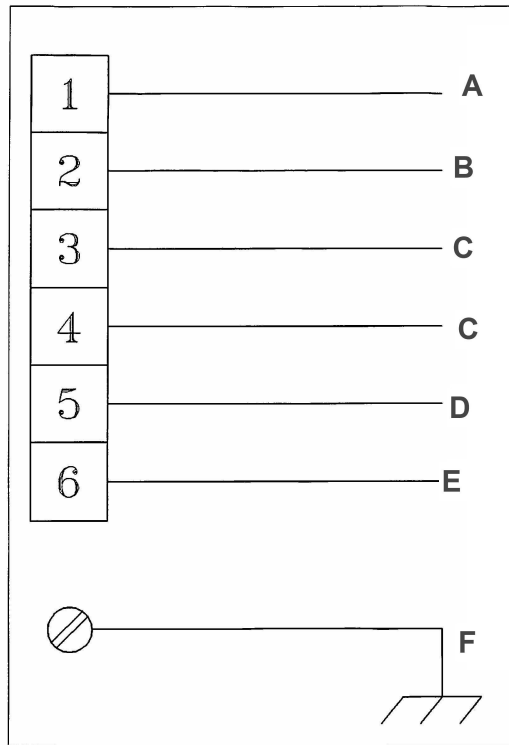
# A Wiring configurations

**Figure A-1: Detector Wiring Terminal**



- A. Power (+)  
18 to 32 Vdc
- B. Return (-)
- C. 0-20 mA (input)
- D. 0-20 mA (output)
- E. RS-485 (+)
- F. RS-485 (-)
- G. Ground

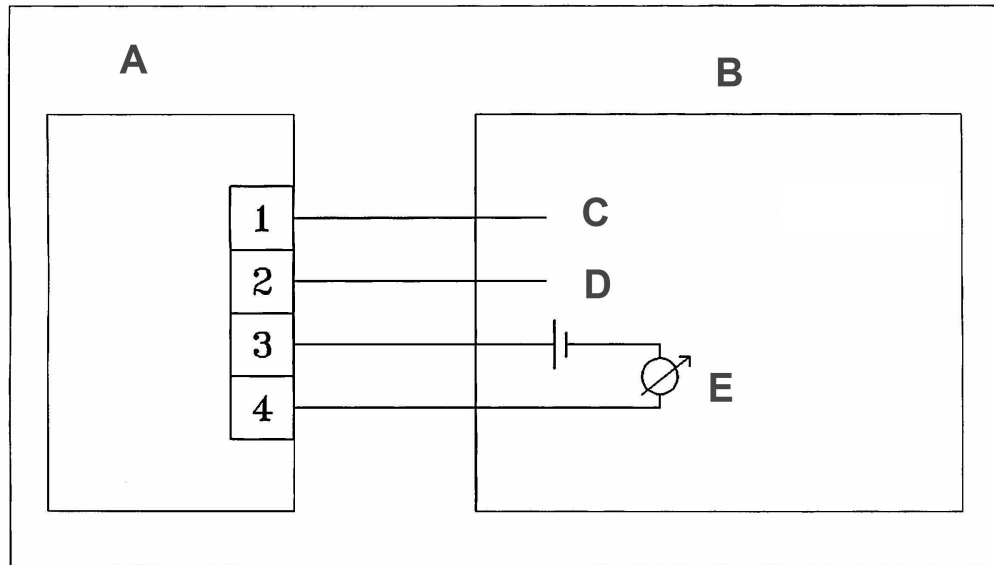
**Figure A-2: Source Wiring Terminal**



- A. Power (+)  
18 to 32 Vdc
- B. Return (-)
- C. Not used
- D. RS-485 (+)
- E. RS-485 (-)
- F. Ground

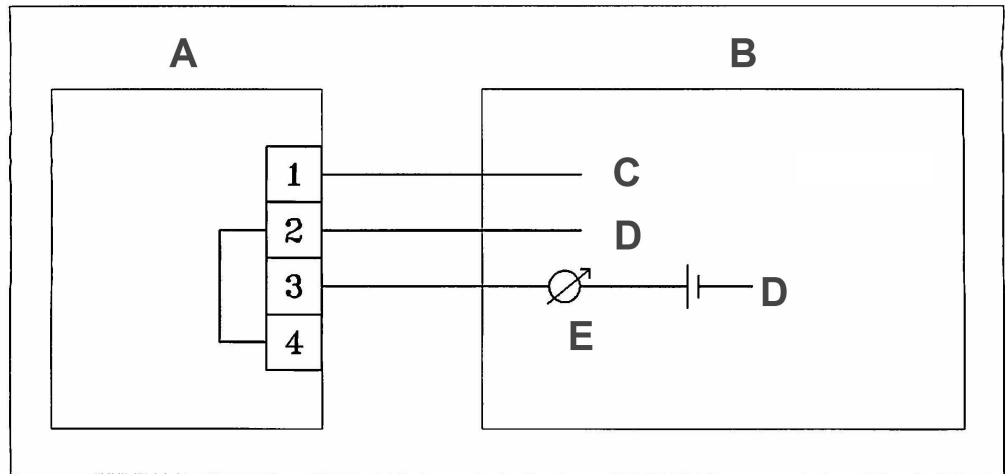


Figure A-3: 0-20 mA Sink 4 Wire



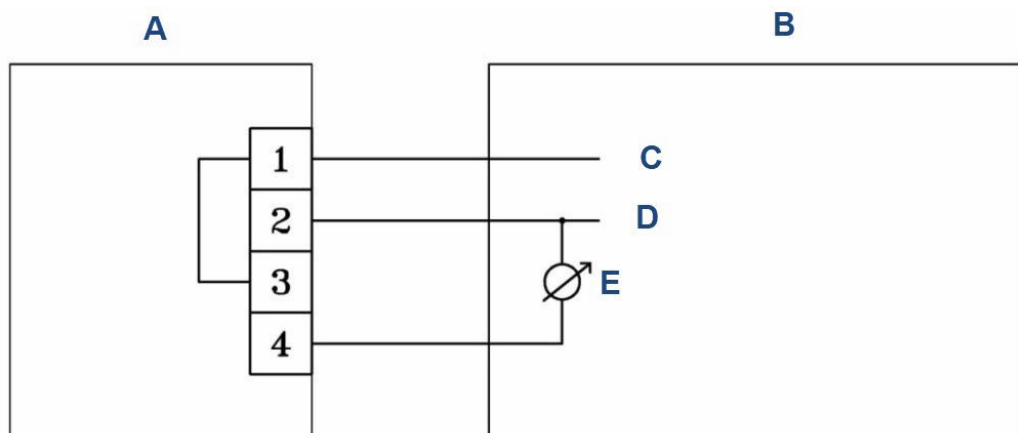
- A. Detector
- B. Controller
- C. Input power: 18-32 Vdc
- D. Return
- E. 0-20 mA meter

**Figure A-4: 0-20 mA Non-Isolated Sink 3 Wire**



- A. Detector
- B. Controller
- C. Input power: 18-32 Vdc
- D. Return
- E. 0-20 mA meter

**Figure A-5: 0-20 mA Source 3 Wire**



- A. Detector
- B. Controller
- C. Input power: 18-32 Vdc
- D. Return
- E. 0-20 mA meter

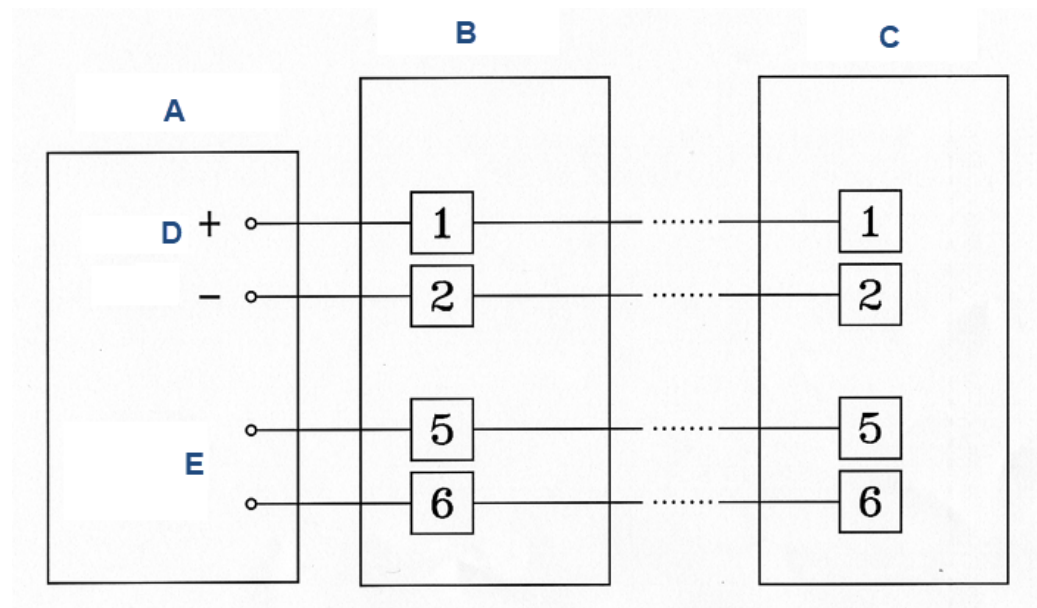
## A.1 RS-485 communication network

Using the RS-485 network capability of the Rosemount 936 detector and additional software, it is possible to connect up to 32 detectors in an addressable system with four wires only (two for power and two for communication).

Using repeaters, the number of detectors can be much larger (32 detectors for each repeater) up to 247 on the same four wires. When using the RS-485 network, it is possible to read the detector status (Fault, Warning, and Alarm).

For more details, consult Emerson.

**Figure A-6: RS-485 Networking for Wiring Option 3**



- A. Controller
- B. First detector
- C. Last detector
- D. Power supply
- E. RS-485 computer port



## B SIL-2 features

### B.1 Safety relevant parameters

Type: B

Structure: 1oo1

HFT: 0

Mean time to repair: 72 hours

Ambient temperature: maximum 149 °F (65 °C)

Proof test interval: 52 weeks (1 year)

<b>λS</b>	1,762 fit
<b>λD</b>	1,722 fit
<b>λDU</b>	97.4 fit
<b>λSD</b>	1,660.7 fit
<b>λDD</b>	1,624.7 fit
<b>DC</b>	94 percent
<b>SFF</b>	97 percent
<b>PFD</b>	5.5 E = 04
<b>PFD percent</b>	5.5 percent
<b>PFH</b>	9.7 E = 08 1/h
<b>PFH percent</b>	9.7 percent

### B.2 General conditions for safe use

- The Rosemount 936 should consist only of the approved hardware and software models.
- Consider the application advice and limitations of the Manual. For calibration and maintenance, consider the regional and national regulations.
- The 24 V power supply must fulfill the requirements for PELV/SELV of EN 60950.
- The HART® and RS-485 interfaces are not allowed to be used for the transmission of safety related data.
- The alert conditions according to SIL-2 can be implemented by an alert signal via the 20 mA current loop.
- After installation and configuration, the operator must verify the set-up parameters and check the function of the Rosemount 936.

- The operator must periodically check the transmitter's alarm conditions together with the typical gas calibration checks. The operator must switch the Rosemount 936 **OFF** and **ON**.
- The connected controller must monitor the 0-20 mA signal current for values below 4 mA and above 20 mA.
- The mean time to repair should be 72 hours.

# C Support

For technical support, contact your local Emerson representative or the Rosemount Technical Support department at [safety.csc@emerson.com](mailto:safety.csc@emerson.com).

## C.1 Return of material

To expedite the return of this product, proper communication between the customer and the factory is important.

### Prerequisites

Before returning a product, email [safety.csc@emerson.com](mailto:safety.csc@emerson.com) for a return material authorization (RMA) number.

### Procedure

1. Include the following information when returning equipment:
  - a. RMA number Emerson provided to you
  - b. Company name and contact information
  - c. Purchase order from your company authorizing return
2. Pack all items to protect them from damage and use anti-static bags or aluminum-backed cardboard as protection from electrostatic damage.
3. Mark all packages with *Return* and include the RMA number.
4. Ship all equipment prepaid to the address provided by your Emerson representative.

---

### Important

Ship all equipment prepaid. Emerson will not accept collect shipments.

---





## D Short range model

The short range model detects hydrogen sulfide (H<sub>2</sub>S) gas at a distance of 17 – 52 ft. (5 – 16 m).

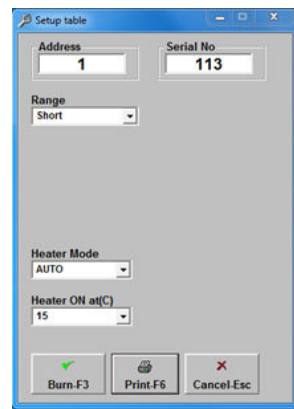
**Table D-1: Rosemount 936 H<sub>2</sub>S Open Path Gas Detector Series**

Range	Source (transmitter) option code	Minimum installation distance (ft./m)	Maximum installation distance (ft./m)
Short	T1	17/5	52/16
Mid	T2	46/14	132/40
Long	T3	115/35	200/60

The detection unit is set by default to the mid/long range. If you require a short range model, prior to installation of the detecting unit, please connect the unit using RS-485 or HART® communication and change the detection range in the setup screen as shown in [Figure D-1](#) and [Figure D-2](#).

Visit our website to download the Winhost software for RS-485 communication, or the device drivers (DD) to enable communication with the device using HART.

**Figure D-1: Using RS-485 and Winhost**



**Figure D-2: Using HART DD**

**Device Setup Menu**

- **Detection Range**
- Window Heater
- Loop Current Mode



# E Declaration of Conformity

**ROSEMOUNT™**

EU\_R451A

## EU Declaration of Conformity

We, at Rosemount Inc., 6021 Innovation Blvd, Shakopee, MN 55379, United States, declare under our sole responsibility that the product listed below is in conformity with the EC-Type Examination Certificate and with the following directives by application of the listed standards:

### 936 Open Path Toxic Gas Detector

<b>Batch No:</b>	<Batch No.>	
<b>Model No:</b>	<Model No.>	
SIRA 16ATEX1224X		
	Ex II 2 (2) G D Ex db eb ib [ib Gb] IIB + H2 T4 Gb Ex tb IIIC T135°C Db Ta = -55 °C to +65 °C	
Issued by the Notified Body:	CSA Group Netherlands B.V. Utrechtseweg 310 (B42), 6812AR ARNHEM, Netherlands 2813	
Surveillance of Quality Assurance Production by:	SGS FIMKO OY, P.O. Box 30 (Särkiniementie 3), 00211 Helsinki, Finland 0598	
<b>Provisions of Directive</b>	<b></b>	<b>Number and Date of Issue of Standard</b>
2014/34/EU	ATEX Directive	EN 60079-0:2012+A11:2013, EN 60079-1:2014, EN 60079-7:2015, EN 60079-28:2015, EN 60079-11:2012, EN 60079-31:2014
2014/30/EU	EMC Directive	EN 50270:2015
2011/65/EU	RoHS Directive	EN 61000-6-3:2006+AMD1:2010 EN50581:2012

Approved By 

Date: 10-Jun-2020

For more information: [www.emerson.com](http://www.emerson.com)

©2021 Emerson. All rights reserved.

Emerson Terms and Conditions of Sale are available upon request. The Emerson logo is a trademark and service mark of Emerson Electric Co. Rosemount is a mark of one of the Emerson family of companies. All other marks are the property of their respective owners.

**ROSEMOUNT™**

