

Rosemount™ 848T High Density Temperature Transmitter with FOUNDATION™ Fieldbus



Contents

Chapter 1	Introduction.....	5
	1.1 Hazard messages.....	5
	1.2 Safety messages.....	5
	1.3 Product recycling/disposal.....	7
Chapter 2	Installation.....	9
	2.1 Mounting	9
	2.2 Wiring.....	16
	2.3 Grounding.....	20
	2.4 Switches.....	23
	2.5 Tagging.....	23
	2.6 Installation	24
Chapter 3	Configuration.....	27
	3.1 Standard configuration.....	27
	3.2 Transmitter configuration.....	27
	3.3 Custom configuration.....	27
	3.4 Configure methods.....	28
	3.5 Configure alarms.....	28
	3.6 Configure damping.....	28
	3.7 Configure the differential sensors.....	28
	3.8 Configure measurement validation.....	29
	3.9 Common configurations for high density applications.....	29
	3.10 Configure blocks.....	33
Chapter 4	Operation and maintenance.....	61
	4.1 FOUNDATION Fieldbus information.....	61
	4.2 Hardware maintenance.....	61
	4.3 Troubleshooting.....	62
Appendix A	Reference data.....	65
	A.1 Functional specifications.....	65
	A.2 Physical specifications.....	66
	A.3 Function blocks.....	67
	A.4 Performance specifications.....	68
	A.5 Dimensional drawings for Rosemount 848T FOUNDATION Fieldbus.....	72
	A.6 Ordering information.....	79
Appendix B	Product certifications.....	83
	B.1 European Directive Information.....	83
	B.2 Ordinary Location Certification.....	83

	B.3 North America.....	83
	B.4 USA.....	83
	B.5 Canada.....	84
	B.6 Europe.....	85
	B.7 International.....	87
	B.8 Brazil.....	89
	B.9 China.....	90
	B.10 Japan.....	92
	B.11 Korea.....	92
	B.12 EAC - Belarus, Kazakhstan, Russia.....	93
	B.13 Combinations.....	93
	B.14 Conduit Plugs and Adapters.....	93
	B.15 Additional Certifications.....	94
	B.16 Intrinsically Safe and Non-Incendive installations.....	95
	B.17 Installation drawings.....	96
Appendix C	FOUNDATION Fieldbus technology.....	105
	C.1 Overview.....	105
	C.2 Function blocks.....	105
	C.3 Device descriptions.....	106
	C.4 Block operation.....	107
	C.5 Network communication.....	107
Appendix D	Function blocks.....	113
	D.1 Analog Input (AI) function block.....	113
	D.2 Multiple analog input (MAI) function block.....	122
	D.3 Input selector function block.....	129

1 Introduction

The Rosemount 848T is optimized for process temperature measurement because it can simultaneously measure eight separate and independent temperature points with one transmitter. You can connect multiple temperature sensor types to each transmitter. In addition, the Rosemount 848T can accept 4-20 mA inputs. The enhanced measurement capability of the Rosemount 848T allows it to communicate these variables to any FOUNDATION™ Fieldbus host or configuration tool.

1.1 Hazard messages

This document uses the following criteria for hazard messages based on ANSI standards Z535.6-2011 (R2017).

⚠ DANGER

Serious injury or death will occur if a hazardous situation is not avoided.

⚠ WARNING

Serious injury or death could occur if a hazardous situation is not avoided.

⚠ CAUTION

Minor or moderate injury will or could occur if a hazardous situation is not avoided.

NOTICE

Data loss, property damage, hardware damage, or software damage can occur if a situation is not avoided. There is no credible risk of physical injury.

Physical access

NOTICE

Unauthorized personnel can potentially cause significant damage and/or misconfiguration of end users' equipment. Protect against all intentional or unintentional unauthorized use.

Physical security is an important part of any security program and fundamental to protecting your system. Restrict physical access to protect users' assets. This is true for all systems used within the facility.

1.2 Safety messages

Read this manual before working with the product. For personal and system safety, and for optimum product performance, ensure you thoroughly understand the contents before installing, using, or maintaining this product.

⚠ WARNING

Explosions could result in death or serious injury.

Installation of this transmitter in an explosive environment must be in accordance with the appropriate local, national, and international standards, codes, and practices. Review the approvals section of this manual for any restrictions associated with a safe installation.

Before connecting a Field Communicator in an explosive atmosphere, make sure the instruments in the loop are installed in accordance with intrinsically safe or non-incendive field wiring practices.

⚠ WARNING

Failure to follow these installation guidelines could result in death or serious injury.

Ensure the transmitter is installed by qualified personnel and in accordance with applicable code of practice.

⚠ WARNING

Process leaks could result in death or serious injury.

Do not remove the thermowell while in operation.

Install and tighten thermowells and sensors before applying pressure.

⚠ WARNING

Electrical shock could cause death or serious injury.

If the sensor is installed in a high-voltage environment and a fault or installation error occurs, high voltage may be present on transmitter leads and terminals.

Use extreme caution when making contact with the leads and terminals.

⚠ CAUTION

This device complies with Part 15 of the FCC Rules. Operation is subject to the following conditions:

- This device may not cause harmful interference.
- This device must accept any interference received, including interference that may cause undesired operation.
- This device must be installed to ensure a minimum antenna separation distance of 7.9 in. (20 cm) from all persons.

NOTICE

Battery hazards remain when cells are discharged.

The power module may be replaced in a hazardous area. The power module has surface resistivity greater than one gigaohm and must be properly installed in the wireless device enclosure. Care must be taken during transportation to and from the point of installation to prevent electrostatic charge build-up.

Shipping considerations for wireless products.

- The unit was shipped to you without the power module installed. Remove the power module prior to any re-shipping.
- Each power module contains two “C” size primary lithium batteries. Primary lithium batteries are regulated in transportation by the U. S. Department of Transportation, and are also covered by IATA (International Air Transport Association), ICAO (International Civil Aviation Organization), and ARD (European Ground Transportation of Dangerous Goods). It is the responsibility of the shipper to ensure compliance with these or any other local requirements. Consult current regulations and requirements before shipping.

1.3 Product recycling/disposal

Recycling of equipment and packaging should be taken into consideration and disposed of in accordance with local and national legislation/regulations.

2 Installation

2.1 Mounting

The transmitter is always mounted remote from the sensor assembly. There are three mounting configurations as follows:

- To a DIN rail without an enclosure
- To a panel with an enclosure
- To a 2 in (51 mm) pipe stand with an enclosure using a pipe mounting kit

2.1.1 Mount to a DIN rail without an enclosure

To mount the transmitter to a DIN rail without an enclosure, follow these steps:

Procedure

1. Pull up the DIN rail mounting clip located on the top back side of the transmitter.
2. Hinge the DIN rail into the slots on the bottom of the transmitter.
3. Tilt the transmitter and place onto the DIN rail. Release the mounting clip. The transmitter should be securely fastened to the DIN rail.

Figure 2-1: Mount the transmitter to a DIN rail

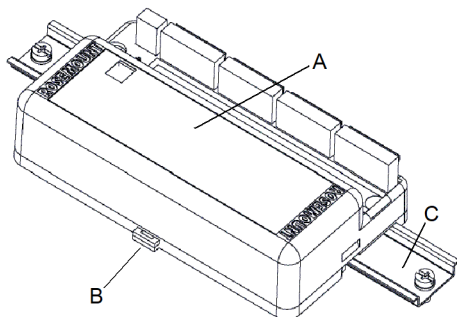

- A. Rosemount 848T without installed enclosure
- B. DIN rail mounting clip
- C. DIN rail

2.1.2 Mount to a panel from an aluminum junction box

Prerequisites

Use four 1/4-20 x 1.25-in. screws.

Procedure

Mount the transmitter to a panel from inside the junction box using one of the following dimension drawings.

Figure 2-2: Aluminum junction box with cable glands (option code JA4)

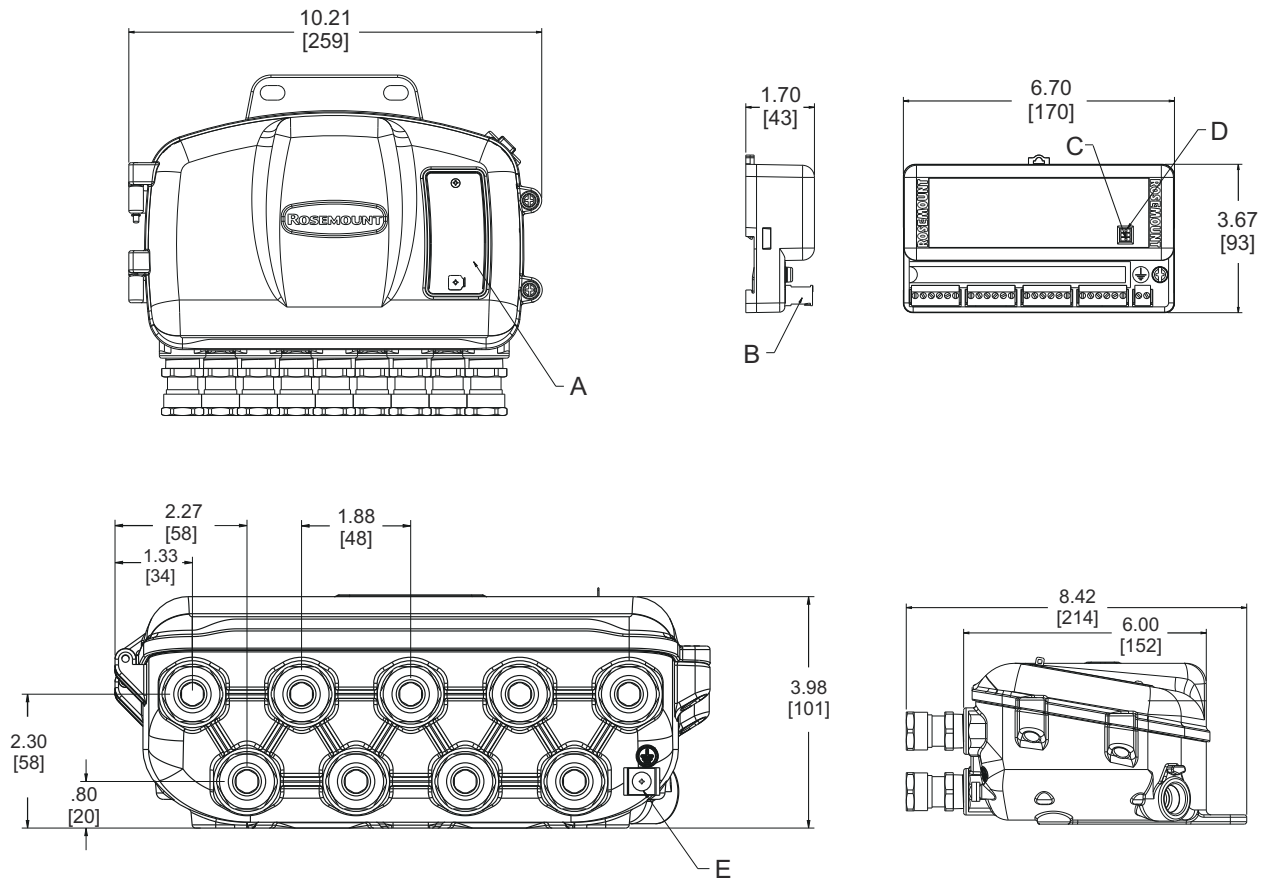

- A. Nameplate
- B. Removable wiring connector
- C. Security switch
- D. Simulation switch
- E. External ground screw (optional)

Dimensions are in inches (millimeters).

Figure 2-3: Aluminum junction box with plugged holes (option code JA5)

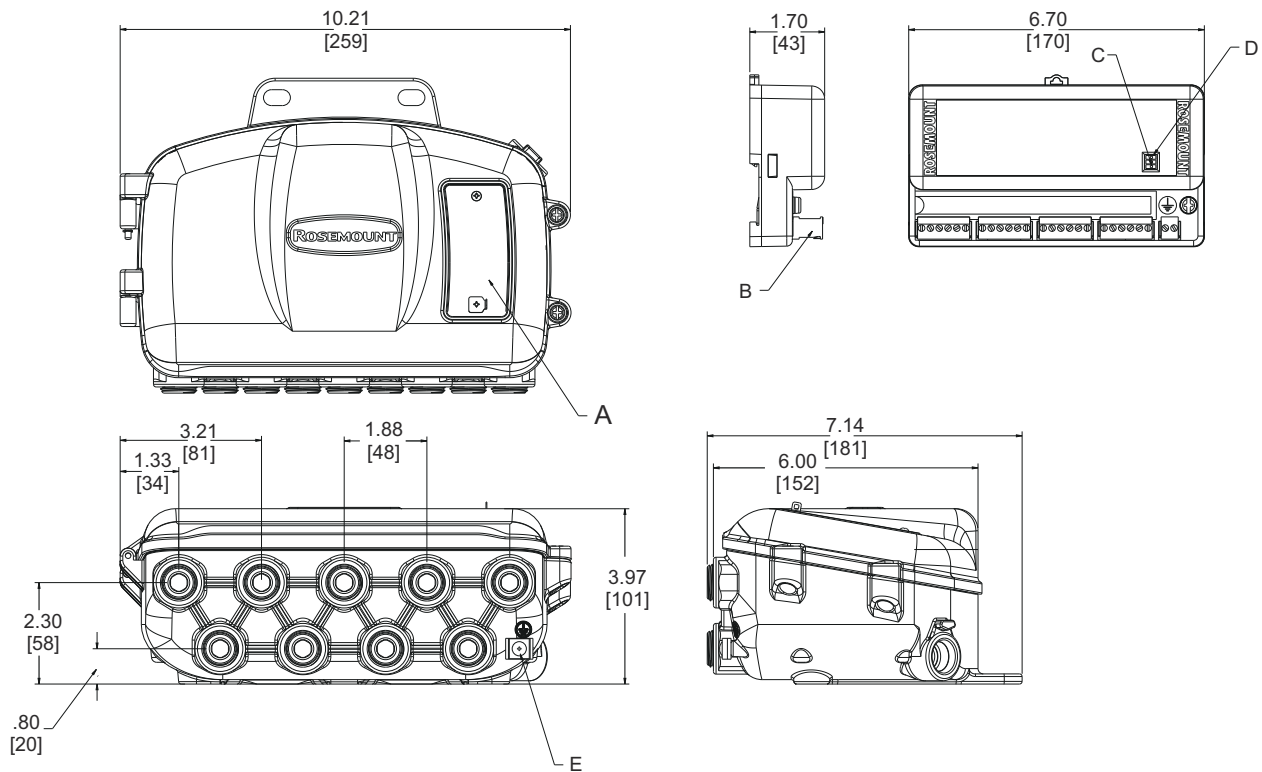

- A. Nameplate
- B. Removable wiring connection
- C. Security switch
- D. Simulation switch
- E. External ground screw (optional)

Dimensions are in inches (millimeters).

2.1.3 Mount to a panel from a stainless steel junction box

Prerequisites

Use two 1/4-20 x 1/2-in. screws.

Procedure

Mount the transmitter to a panel from inside the junction box using one of the following dimension drawings.

Figure 2-4: Stainless steel junction box with cable glands (option code JS2)

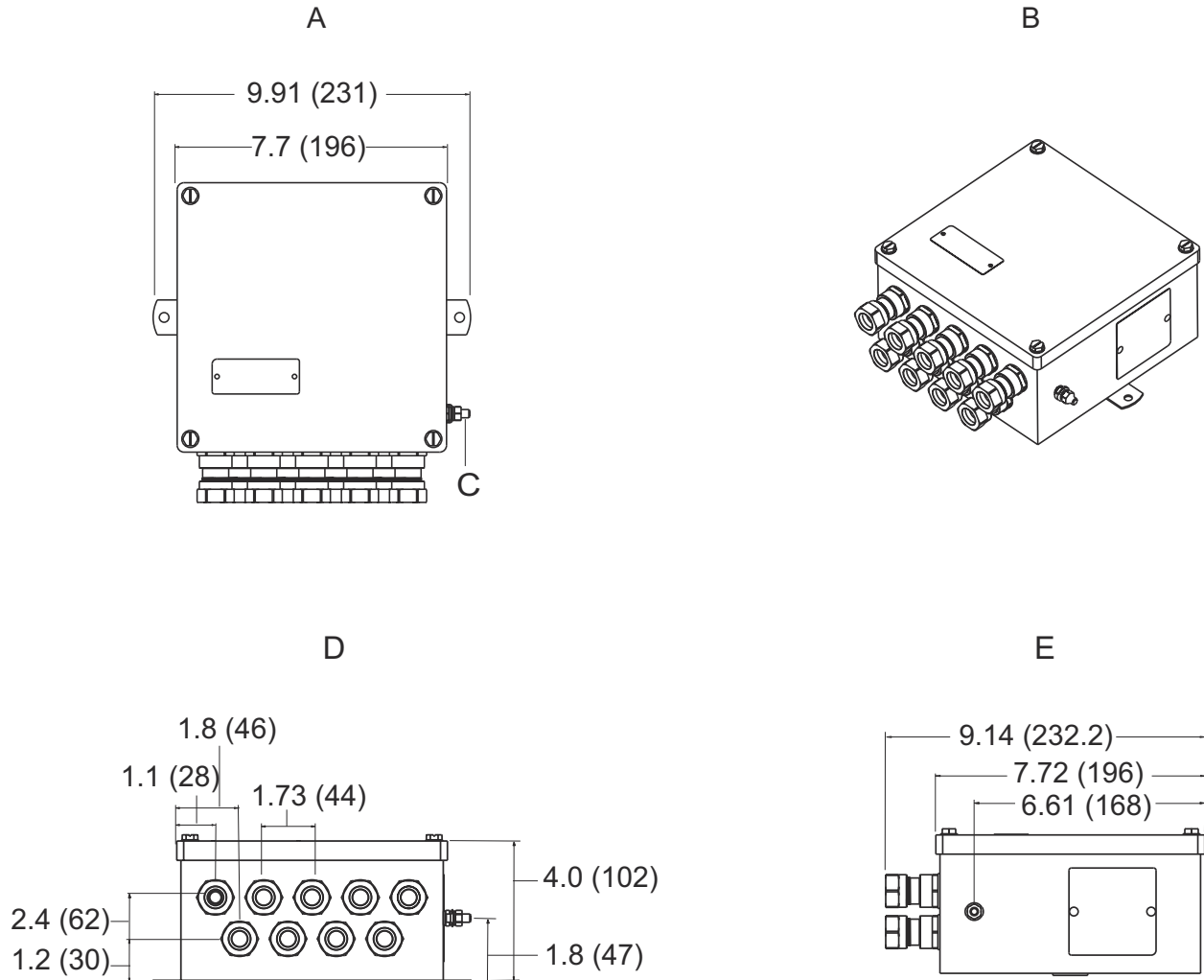

- A. Top view
- B. 3-D view
- C. Ground screw
- D. Front view
- E. Side view

Dimensions are in inches (millimeters).

Figure 2-5: Stainless steel junction box with a conduit entry (option code JS3)

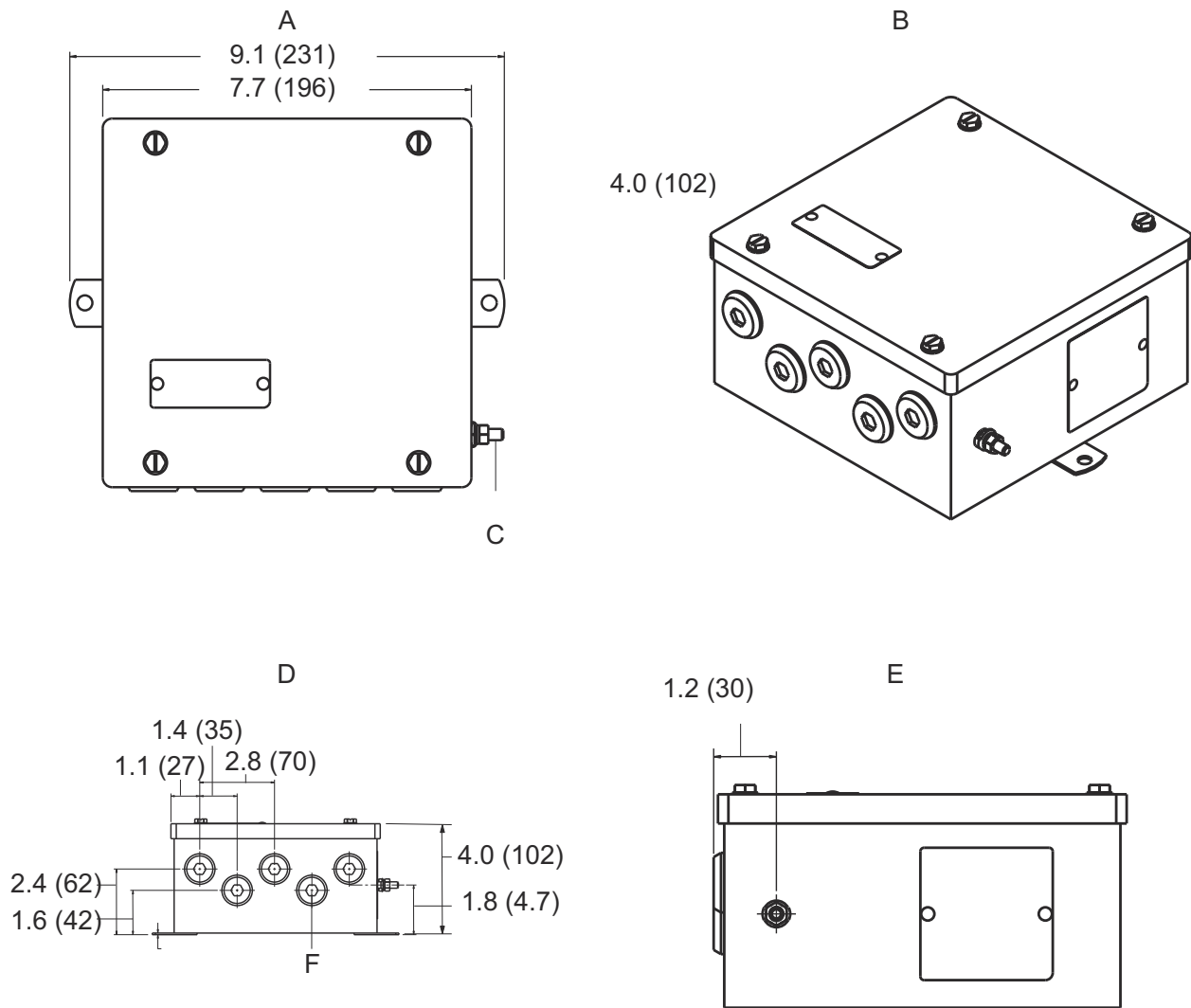

- A. Top view
- B. 3-D view
- C. Ground screw
- D. Front view
- E. Side view
- F. Five plugged 0.86 in (21.8 mm) diameter holes suitable for installing 1/2-in. NPT fittings

Dimensions are in inches (millimeters).

2.1.4 Mount to a 2 in (51 mm) pipe stand

Procedure

Use the optional mounting bracket (option code B6) to mount the transmitter to a 2 in (51 mm) pipe stand when using a junction box.

Figure 2-6: Mount an aluminum junction box

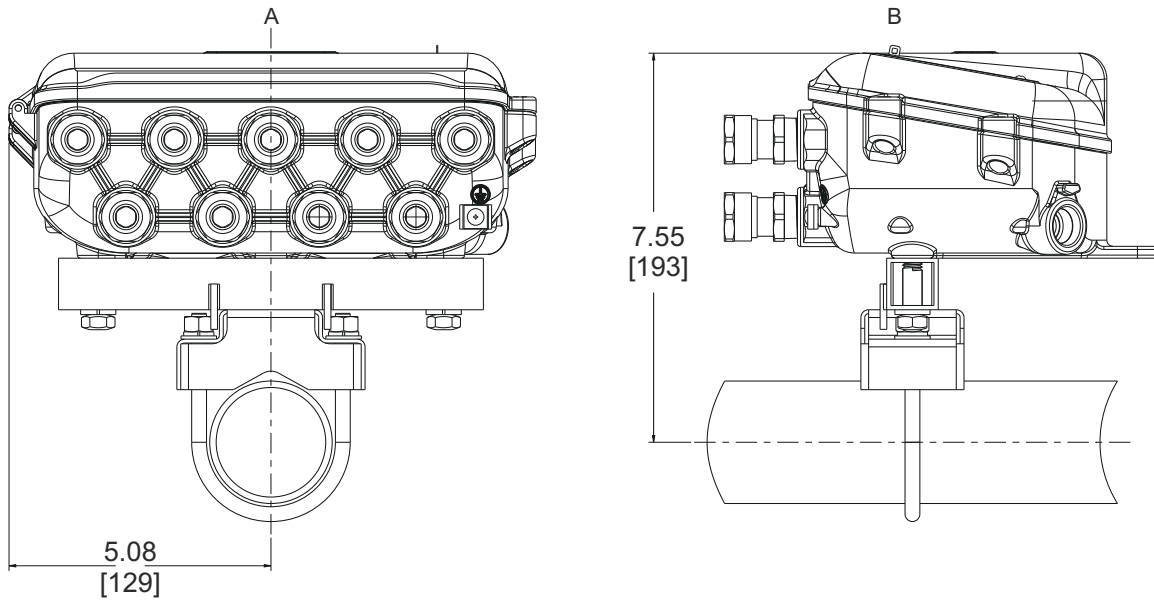

- A. Front view
- B. Side view

Dimensions are in inches (millimeters)

Figure 2-7: Mount a stainless steel junction box

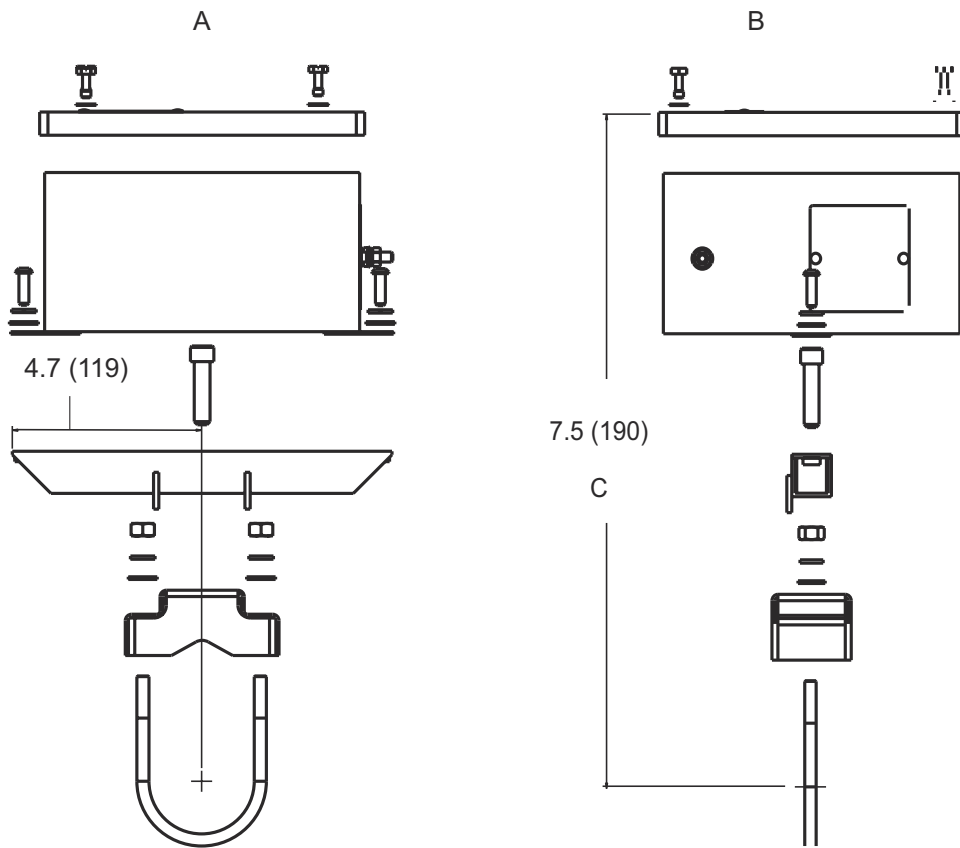

- A. Front view
- B. Side view
- C. Fully assembled

Dimensions are in inches (millimeters)

Figure 2-8: Mount aluminum on a vertical pipe

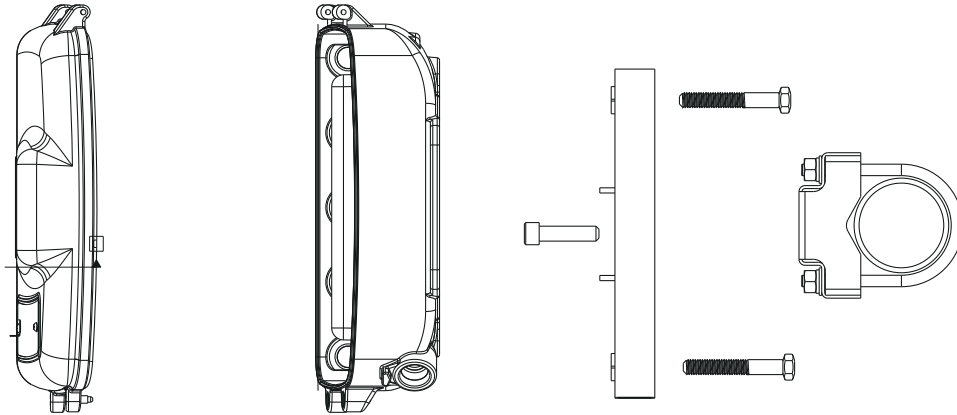
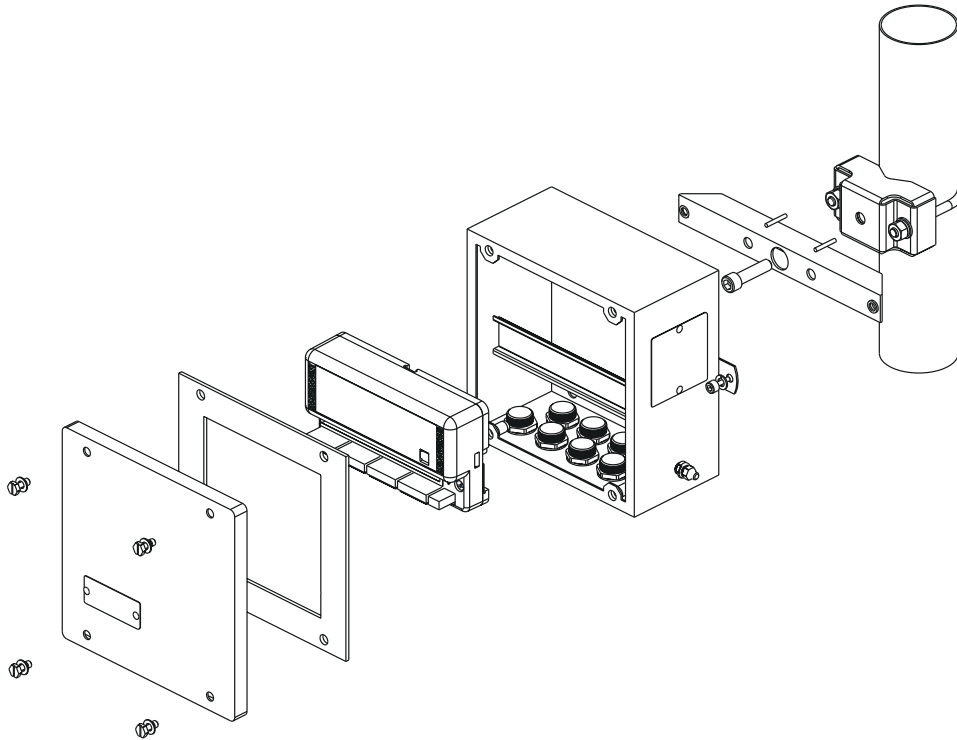

Figure 2-9: Mount stainless steel on vertical pipe



2.2 Wiring

⚠ If the sensor is installed in a high-voltage environment and a fault condition or installation error occurs, the sensor leads and transmitter terminals could carry lethal voltages. Use extreme caution when making contact with the leads and terminals.

NOTICE

Do not apply high voltage (e.g. AC line voltage) to the transmitter terminals. Abnormally high voltage can damage the unit (bus terminals are rated to 42.4 VDC).

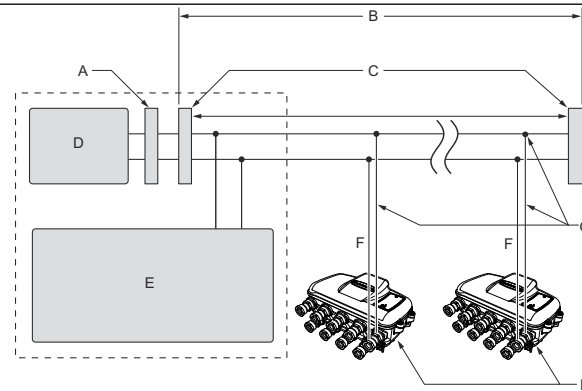

- A. Integrated power conditioner and filter
- B. 6234 ft. (1900 m) max (depending upon cable characteristics)
- C. Terminators (trunk)
- D. Power supply
- E. FOUNDATION Fieldbus host or configuration tool
- F. Spurs
- G. Signal wiring
- H. Devices 1-16 (intrinsically safe installations may allow fewer devices per I.S. barrier)

2.2.1 Connections

The Rosemount 848T transmitter is compatible with 2 or 3-wire RTD, thermocouple, ohm, and millivolt sensor types. [Figure 2-10](#) shows the correct input connections to the sensor terminals on the transmitter. The Rosemount 848T can also accept inputs from analog devices using the optional analog input connector. [Figure 2-11](#) shows the correct input connections to the analog input connector when installed on the transmitter. Tighten the terminal screws to ensure proper connection.

Figure 2-10: Sensor wiring diagram

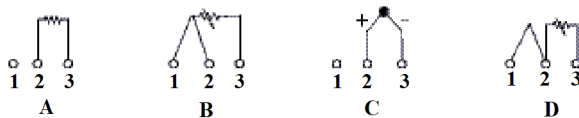

- A. 2-wire RTD and ohms
- B. 3-wire RTD and ohms (Emerson provides 4-wire sensors for all single-element RTDs; use these RTDs in 3-wire configurations by clipping the fourth lead or leaving it disconnected and insulated with electrical tape.)
- C. Thermocouples/ohms and millivolts
- D. 2-wire RTD with compensation loop (transmitter must be configured for a 3-wire RTD in order to recognize an RTD with a compensation loop)

RTD or ohm inputs

Various RTD configurations, including 2-wire and 3-wire are used in industrial applications. If the transmitter is mounted remotely from a 3-wire RTD, it will operate within specifications, without recalibration, for lead wire resistances of up to 60 ohms per lead (equivalent to 6,000 ft (1,829 m) of 20 AWG (0.518 mm²) wire). If using a 2-wire RTD, both RTD leads are in series with the sensor element, so errors can occur if the lead lengths exceed one foot of 20 AWG (0.518 mm²) wire. Compensation for this error is provided when using 3-wire RTDs.

Thermocouple or millivolt inputs

Use appropriate thermocouple extension wire to connect the thermocouple to the transmitter. Make connections for millivolt inputs using copper wire. Use shielding for long runs of wire.

Analog inputs

The analog connector converts the 4–20 mA signal to a 20–100 mV signal that can be read by the transmitter and transmitted using FOUNDATION Fieldbus.

Use the following steps when installing the transmitter with the analog connector:

Procedure

1. The Rosemount 848T, when ordered with option code S002, comes with four analog connectors. Replace the standard connector with the analog connector on the desired channels.
2. Wire one or two analog transmitters to the analog connector according to [Figure 2-11](#). There is space available on the analog connector label for identification of the analog inputs.

Note

Power supply should be rated to support the connected transmitter(s).

3. If the analog transmitters can communicate using HART[®] protocol, the analog connectors are supplied with the ability to switch in a 250 ohm resistor for HART communication (see [Figure 2-11](#)). One switch is supplied for each input (top switch for A inputs and bottom switch for B inputs). Setting the switch in the ON position (to the right) bypasses the 250 ohm resistor. Terminals are provided for each analog input to connect a field communicator for local configuration.

Figure 2-11: Rosemount 848T Analog Input Wiring Diagram

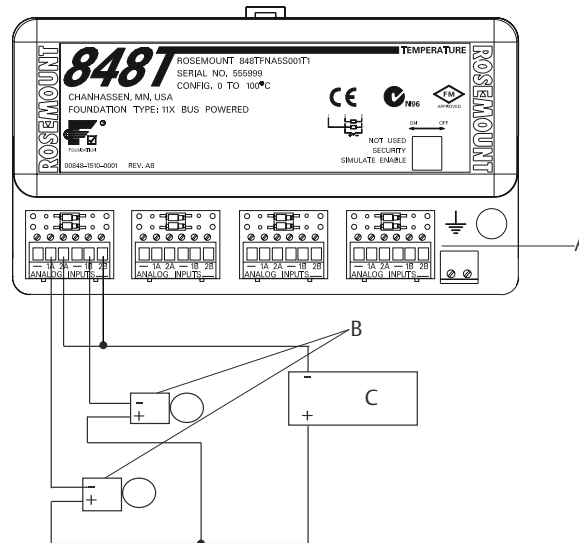

- A. Analog input connectors
- B. Analog transmitters
- C. Power supply

2.2.2 Power supply

Connect the power supply

The transmitter requires between 9 and 32 VDC to operate and provide complete functionality. The DC power supply should provide power with less than 2% ripple. A fieldbus segment requires a power conditioner to isolate the power supply filter and decouple the segment from other segments attached to the same power supply.

⚠ All power to the transmitter is supplied over the signal wiring. Signal wiring should be shielded, twisted pair for best results in electrically noisy environments.

NOTICE

For best performance, do not use unshielded signal wiring in open trays with power wiring or near heavy electrical equipment.

Use ordinary copper wire of sufficient size to ensure the voltage across the transmitter power terminals does not go below 9 VDC. The power terminals are polarity insensitive. To power the transmitter:

Procedure

1. Connect the power leads to the terminals marked **Bus**, as shown in [Figure 2-12](#).
2. Tighten the terminal screws to ensure adequate contact. No additional power wiring is necessary.

Figure 2-12: Transmitter label

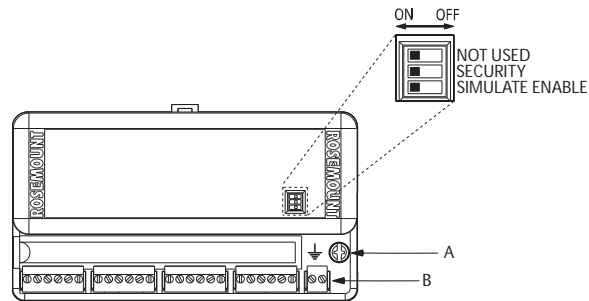

- A. Ground (required with T1 option)
- B. Connect power leads here

2.2.3 Surges/transients

The transmitter will withstand electrical transients encountered through static discharges or induced switching transients. However, a transient protection option (option code T1) is available to protect the transmitter against high-energy transients. The device must be properly grounded using the ground terminal (see Figure 2-12).

2.3 Grounding

The Rosemount 848T transmitter provides input/output isolation up to 620 V rms.

NOTICE

Neither conductor of the fieldbus segment can be grounded. Grounding out one of the signal wires will shut down the entire fieldbus segment.

2.3.1 Shielded wire

Each process installation has different requirements for grounding. Use the grounding options recommended by the facility for the specific sensor type or begin with grounding option 1 (most common).

Ungrounded thermocouple, mV, and RTD/ohm inputs

There are two options for ungrounded thermocouple, mV, and RTD/ohm inputs.

Option 1

Procedure

1. Connect signal wiring shield to the sensor wiring shield(s).
2. Ensure shields are tied together and electrically isolated from transmitter enclosure.
3. Only ground shield at the power supply end.
4. Ensure sensor shield(s) is electrically isolated from the surrounding grounded fixtures.

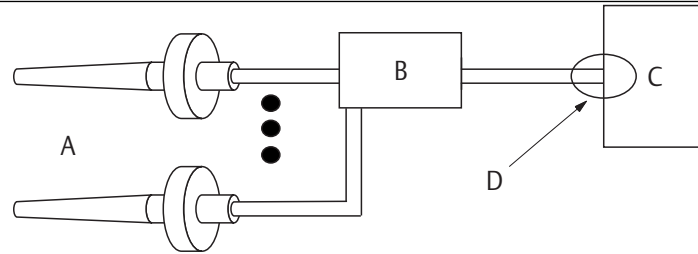

- A. Sensor wires
- B. Rosemount™ 848T
- C. Power supply
- D. Shield ground point

Option 2

Procedure

1. If the enclosure is grounded, connect sensor wiring shield(s) to the transmitter enclosure.
2. Ensure sensor shield(s) is electrically isolated from surrounding fixtures that may be grounded.
3. Ground signal wiring shield at the power supply end.

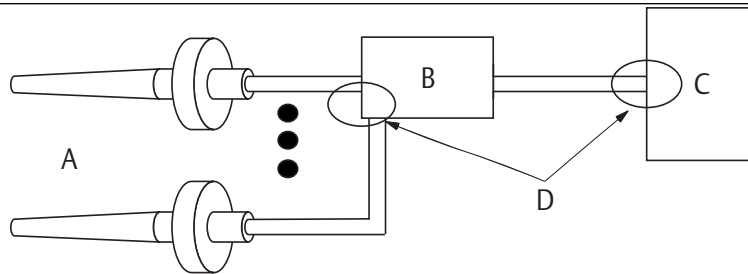

- A. Sensor wires
- B. Rosemount 848T
- C. Power supply
- D. Shield ground points

Grounded thermocouple inputs

Procedure

1. Ground sensor wiring shield(s) at the sensor.
2. Ensure that the sensor wiring and signal wiring shields are electrically isolated from the transmitter enclosure.
3. Do not connect the signal wiring shield to the sensor wiring shield(s).
4. Ground signal wiring shield at the power supply end.

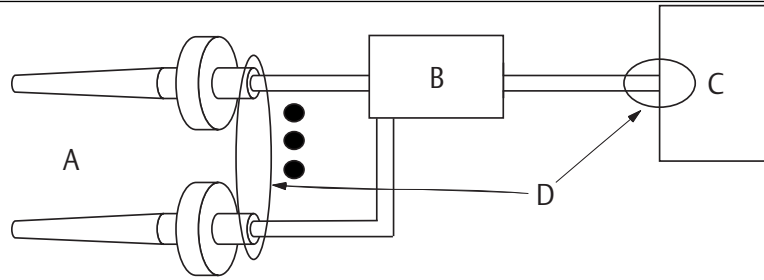

- A. Sensor wires
- B. Rosemount 848T
- C. Power supply
- D. Shield ground points

Analog device inputs

Procedure

1. Ground analog signal wire at the power supply of the analog devices.
2. Ensure the analog signal wire and the fieldbus signal wire shields are electrically isolated from the transmitter enclosure.
3. Do not connect the analog signal wire shield to the fieldbus signal wire shield.
4. Ground fieldbus signal wire shield at the power supply end.

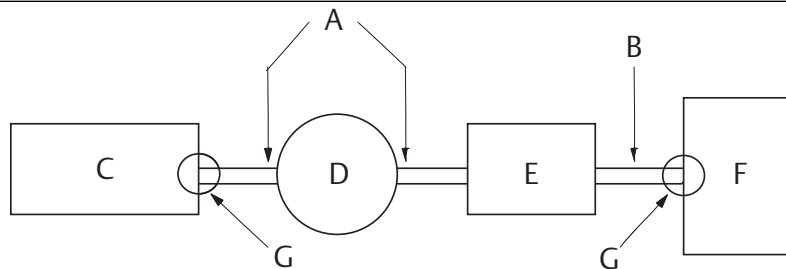

- A. 4-20 mA loop
- B. FOUNDATION Fieldbus
- C. Analog device power supply
- D. Analog device
- E. Rosemount 848T
- F. Power supply
- G. Shield ground points

2.3.2 Transmitter enclosure (optional)

Procedure

Ground the transmitter in accordance with local electrical requirements.

2.4 Switches

Figure 2-13: Switch location on the transmitter

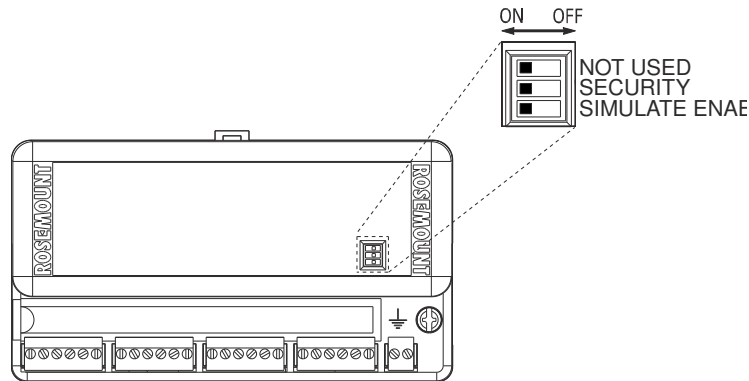

Security

After configuring the transmitter, the data can be protected from unwarranted changes. Each transmitter is equipped with a security switch that can be positioned ON to prevent the accidental or deliberate change of configuration data. This switch is located on the front side of the electronics module and is labeled SECURITY.

For the switch location on the transmitter label, see [Figure 2-13](#).

Simulate enable

The switch labeled SIMULATE ENABLE is used in conjunction with the Analog Input (AI) and Multiple Analog Input (MAI) function blocks. This switch is used to simulate temperature measurement.

Not used

The switch is not functional.

2.5 Tagging

Commissioning tag

The Rosemount 848T has been supplied with a removable commissioning tag that contains both the Device ID (the unique code that identifies a particular device in the absence of a device tag) and a space to record the device tag (the operational identification for the device as defined by the Piping and Instrumentation Diagram [P&ID]).

When commissioning more than one device on a fieldbus segment, it can be difficult to identify which device is at a particular location. The removable tag, provided with the transmitter, can aid in this process by linking the Device ID to its physical location. The installer should note the physical location of the transmitter on both the upper and lower location of the commissioning tag. The bottom portion should be torn off for each device on the segment and used for commissioning the segment in the control system.

Figure 2-14: Commissioning tag

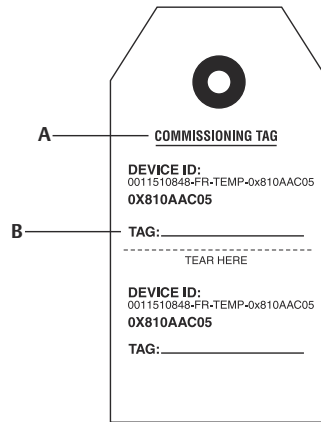

- A. Device ID
- B. Device tag to denote physical location

Transmitter tag

Hardware	<ul style="list-style-type: none"> • Tagged in accordance with customer requirements • Permanently attached to the transmitter
Software	<ul style="list-style-type: none"> • The transmitter can store up to 32 characters. • If no characters are specified, the first 30 characters of the hardware tag will be used.

Sensor tag

Hardware	<ul style="list-style-type: none"> • A plastic tag is provided to record identification of eight sensors. • This information can be printed at the factory upon request. • In the field, the tag can be removed, printed onto, and reattached to the transmitter.
Software	<ul style="list-style-type: none"> • If sensor tagging is requested, the Transducer Block SERIAL_NUMBER parameters will be set at the factory. • The SERIAL_NUMBER parameters can be updated in the field.

2.6 Installation

2.6.1 Using cable glands

Procedure

1. Remove the junction box cover by unscrewing the cover screws.

2. Run the sensor and power/signal wires through the appropriate cable glands (see [Figure 2-15](#)).
3. Install the sensor wires into the correct screw terminals (follow the label on the electronics module).
4. Install the power/signal wires onto the correct screw terminals. Power is polarity insensitive, allowing the user to connect positive (+) or negative (-) to either fieldbus wiring terminal labeled “Bus”.
5. Replace the enclosure cover and securely tighten all cover screws.

Figure 2-15: Installing the transmitter with cable glands

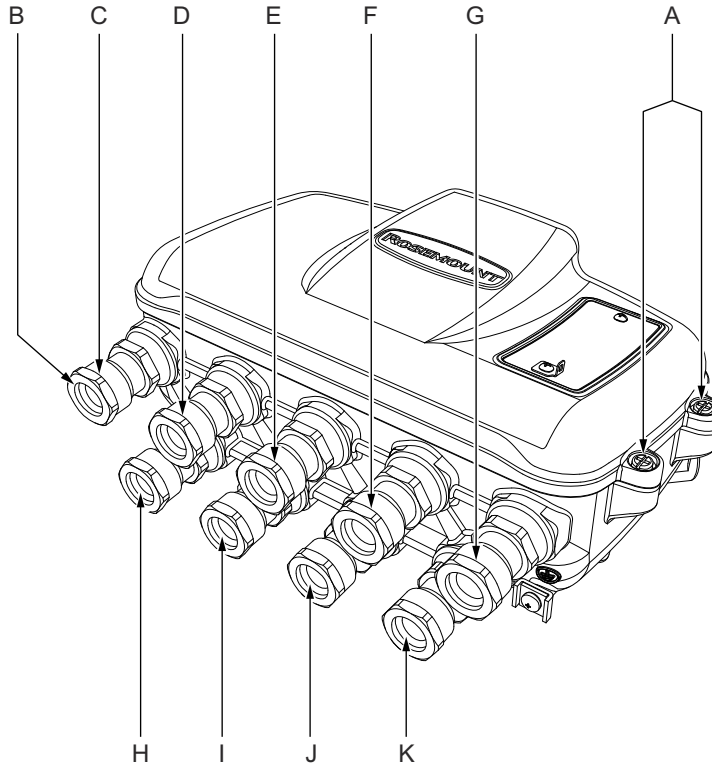

- A. Enclosure cover screws (2)
- B. Cable glands (9)
- C. Sensor 1
- D. Sensor 3
- E. Sensor 5
- F. Sensor 7
- G. Power/signal
- H. Sensor 2
- I. Sensor 4
- J. Sensor 6
- K. Sensor 8

3 Configuration

3.1 Standard configuration

Each FOUNDATION Fieldbus configuration tool or host system has a different way of displaying and performing configurations. Some will use Device Descriptions (DDs) and DD Methods to make configuration and displaying of data consistent across host platforms.

Unless otherwise specified, the transmitter will be shipped with the following configuration (default):

Table 3-1: Standard configuration settings

Sensor Type ⁽¹⁾	Type J Thermocouple
Damping ⁽¹⁾	5 seconds
Measurement Units ⁽¹⁾	°C
Output ⁽¹⁾	Linear with Temperature
Line Voltage Filter ⁽¹⁾	60 Hz
Temperature Specific Blocks	<ul style="list-style-type: none"> • Transducer Block (1)
FOUNDATION Fieldbus Function Blocks	<ul style="list-style-type: none"> • Analog Input (8) • Multiple Analog Input (2) • Input Selector (4)

(1) For all eight sensors

Refer to the systems documentation to perform configuration changes using a FOUNDATION Fieldbus host or configuration tool.

Note

To make configuration changes, ensure that the block is Out of Service (OOS) by setting the `MODE_BLK.TARGET` to `OOS`, or set the `SENSOR_MODE` to `Configuration`.

3.2 Transmitter configuration

The transmitter is available with the standard configuration setting. The configuration settings and block configuration may be changed in the field with the Emerson Process Management Systems DeltaV™, with AMS™ **inside**, or other FOUNDATION Fieldbus host or configuration tool.

3.3 Custom configuration

Custom configurations are specified when ordering.

3.4 Configure methods

For FOUNDATION Fieldbus hosts or configuration tools that support device description (DD) methods, there are two configuration methods available in the transducer block. These methods are included with the DD software.

- Sensor Configuration
- Sensor Input Trim (user input trim)

See the host system documentation for information on running DD methods from the host system. If the FOUNDATION Fieldbus host or configuration tool does not support DD methods, for information on how to modify sensor configuration parameters, refer to [Configure blocks](#).

3.5 Configure alarms

Use the following steps to configure the alarms, which are located in the Resource Function Block:

Procedure

1. Set the resource block to **OOS**.
2. Set **WRITE_PRI** to the appropriate alarm level (**WRITE_PRI** has a selectable range of priorities from 0 to 15, see [Table 3-4](#). Set the other block alarm parameters at this time.
3. Set **CONFIRM_TIME** to the time, in 1/32 of a millisecond, that the device will wait for confirmation of receiving a report before trying again (the device does not retry if **CONFIRM_TIME** is 0).
4. Set **LIM_NOTIFY** to a value between zero and **MAX_NOTIFY**. **LIM_NOTIFY** is the maximum number of alert reports allowed before the operator needs to acknowledge an alarm condition.
5. Enable the reports bit in **FEATURES_SEL**. (When multi-bit alerts is enabled, every active alarm is visible for any of the eight sensors, generated by a Plantweb™ and field diagnostics alert. This is different than only viewing the highest priority alarm.)
6. Set the resource block to **AUTO**.

For modifying alarms on individual function blocks (AI or ISEL blocks), refer to [Function blocks](#).

3.6 Configure damping

Use the following steps to configure the damping, which is located in the transducer function block:

Procedure

1. Set **Sensor Mode** to **Out of Service**.
2. Change **DAMPING** to the desired filter rate (0.0 to 32.0 seconds).
3. Set **Sensor Mode** to **In Service**.

3.7 Configure the differential sensors

Use the following steps to configure the differential sensors:

Procedure

1. Set **Dual Sensor Mode** to **Out of Service**.
2. Set **Input A** and **Input B** to the sensor values that are to be used in the differential equation $\text{diff} = A - B$.

Note

Unit types must be the same.

3. Set the **DUAL_SENSOR_CALC** to either **Not Used**, **Absolute**, or **INPUT A minus INPUT B**.
4. Set **Dual Sensor Mode** to **In Service**.

3.8 Configure measurement validation

Use the following steps to configure measurement validation:

Procedure

1. Set mode to **Disabled** for specific sensor.
2. Select sample rate. 1-10 sec/sample is available. 1 second/sample is preferred for sensor degradation. The higher the number of seconds between samples, the more emphasis put on process variation.
3. Select **Deviation Limit** from 0 to 10 units. If deviation limit is exceeded, a status event will be triggered.
4. Select **Increasing Limit**. Sets the limit for increasing rate of change. If limit is exceeded, a status event will be triggered.
5. Select **Decreasing Limit**. Sets the limit for decreasing rate of change. If limit is exceeded, a status event will be triggered.

Note

The decreasing limit selected is required to be a negative value.

6. Set the **Deadband** from 0 to 90%. This threshold is used to clear the PV status.
7. Set **Status Priority**. This determines what happens when the specific limit has been exceeded.

No Alert	Ignores limit settings
Advisory	Sets a Advisory Plant Web Alert, but does not do anything with PV status
Warning	Sets a Maintenance Plant Web Alert and sets PV status to uncertain
Failure	Sets a Failure Plant Web Alert and sets PV status to Bad

8. Set mode to **Enabled** for specific sensor.

3.9 Common configurations for high density applications

For the application to work properly, configure the links between the function blocks and schedule the order of their execution. The Graphical User Interface (GUI) provided by the FOUNDATION Fieldbus host or configuration tool will allow easy configuration.

The measurement strategies shown in this section represent some of the common types of configurations available in the Rosemount 848T. Although the appearance of the GUI screens will vary from host to host, the configuration logic is the same.

NOTICE

Ensure the host system or configuration tool is properly configured before downloading the transmitter configuration. If configured improperly, the FOUNDATION Fieldbus host or configuration tool could overwrite the default transmitter configuration.

3.9.1 Configure a typical profiling application

Procedure

1. Place the Multiple Analog Input (MAI) function block in OOS mode (set **MODE_BLK.TARGET** to **OOS**).
2. Set **CHANNEL** = channels 1 to 8. Although the **CHANNEL_X** parameters remain writable, **CHANNEL_X** can only be set = X when **CHANNEL** = 1.
3. Set **L_TYPE** to direct or indirect.
4. Set **XD_SCALE** (transducer measurement scaling) to the appropriate upper and lower range values, the appropriate sensor units, and display decimal point.
5. Set **OUT_SCALE** (MAI output scaling) to the appropriate upper and lower range values, the appropriate sensor units, and display decimal point.
6. Place the **MAI Function Block** in auto mode.
7. Verify that the function blocks are scheduled.

Example

The following illustration describes a distillation column temperature profile where all channels have the same sensor units (°C, °F, etc.).

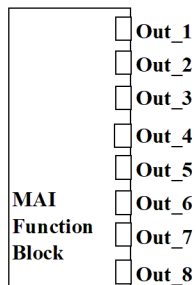

3.9.2 Monitor an application with a single selection

Procedure

1. Link the MAI outputs to the ISEL inputs.
2. Place the Multiple Analog Input (MAI) function block in OOS mode (set **MODE_BLK.TARGET** to **OOS**).
3. Set **CHANNEL** = channels 1 to 8. Although the **CHANNEL_X** parameters remain writable, **CHANNEL_X** can only be set = X when **CHANNEL** = 1.
4. Set **L_TYPE** to direct or indirect.

5. Set **XD_SCALE** (transducer measurement scaling) to the appropriate upper and lower range values, the appropriate sensor units, and display decimal point.
6. Set **OUT_SCALE** (MAI output scaling) to the appropriate upper and lower range values, the appropriate sensor units, and display decimal point.
7. Place the MAI function block in auto mode.
8. Place the Input Selector (ISEL) function block in OOS mode by setting **MODE_BLK.TARGET** to **OOS**.
9. Set **OUT_RANGE** to match the **OUT_SCALE** in the MAI block.
10. Set **SELECT_TYPE** to the desired function (**Maximum Value, Minimum Value, First Good Value, Midpoint Value, or Average Value**).
11. Set the alarm limits and parameters if necessary.
12. Place the ISEL function block in auto mode.
13. Verify that the function blocks are scheduled.

Example

The following illustration describes the average exhaust temperature of gas and turbine where there is a single alarm level for all inputs.

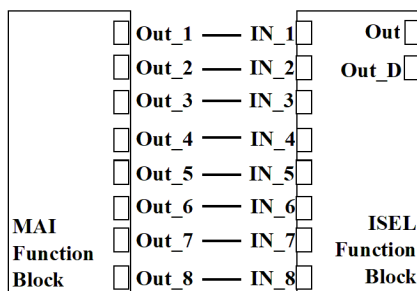

3.9.3 Measure temperature points individually

Procedure

1. Place the first Analog Input (AI) function block in OOS mode (set **MODE_BLK.TARGET** to **OOS**).
2. Set **CHANNEL** to the appropriate channel value. For a listing of channel definitions, refer to [Table 3-4](#).
3. Set **L_TYPE** to direct.
4. Set **XD_SCALE** (transducer measurement scaling) to the appropriate upper and lower range values, the appropriate sensor units, and display decimal point.
5. Set **OUT_SCALE** (AI output scaling) to the appropriate upper and lower range values, the appropriate sensor units, and display decimal point.
6. Set the alarm limits and parameters if necessary.
7. Place the AI function block in auto mode.
8. Repeat steps 1 through 7 for each AI function block.
9. Verify the function blocks are scheduled.

Example

The following illustration describes the miscellaneous monitoring of temperature in a close proximity where each channel can have different sensor inputs with different units and there are independent alarm levels for each input.

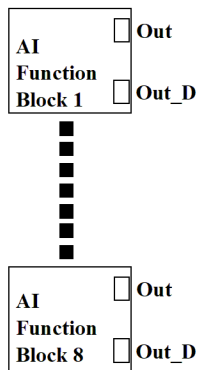

3.9.4 Interface analog transmitters to FOUNDATION Fieldbus

Configure the transducer block

Use the sensor configuration method to set the sensor type to mV – 2-wire for the applicable transducer block or follow these steps.

Procedure

1. Set the **MODE_BLK.TARGET** to **OOS** mode, or set the **SENSOR_MODE** to configuration.
2. Set the **SENSOR** to mV.
3. Set the **MODE_BLK.TARGET** to **AUTO**, or set the **SENSOR_MODE** to operation.

Configure the multiple analog input or the analog input block

Follow these steps to configure the applicable block.

Procedure

1. Set the **MODE_BLK.TARGET** to **OOS** mode, or set the **SENSOR_MODE** to configuration.
2. Set **CHANNEL** to the transducer block configured for the analog input.
3. Set **XD_SCALE.EU_0** to 20
 - a) Set **XD_SCALE.EU_100** to 100 .
 - b) Set **XD_SCALE.ENGUNITS** to mV.
4. Set **OUT_SCALE** to match the desired scale and units for the connected analog transmitter.

Flow Example: 0 – 200 gpm

OUT_SCALE.EU_0 = 0

Flow Example: 0 – 200 gpm

OUT_SCALE.EU_100 = 200

OUT_SCALE.ENGUNITS = gpm

5. Set L_TYPE to INDIRECT.
6. Set the MODE_BLK.TARGET to AUTO, or set the SENSOR_MODE to operation.

3.10 Configure blocks

3.10.1 Resource block

The resource block defines the physical resources of the device including type of measurement, memory, etc. The resource block also defines functionality, such as shed times, that is common across multiple blocks. The block has no linkable inputs or outputs and it performs memory-level diagnostics.

Table 3-2: Resource block parameters

Number	Parameter	Description
01	ST_REV	The revision level of the static data associated with the function block.
02	TAG_DESC	The user description of the intended application of the block.
03	STRATEGY	The strategy field can be used to identify grouping of blocks.
04	ALERT_KEY	The identification number of the plant unit.
05	MODE_BLK	The actual, target, permitted, and normal modes of the block. For further description, see the Mode parameter formal model in FF-890.
06	BLOCK_ERR	This parameter reflects the error status associated with the hardware or software components associated with a block. Multiple errors may be shown. For a list of enumeration values, see FF-890, Block_Err formal model.
07	RS_STATE	State of the function block application state machine. For a list of enumeration values, see FF-890.
08	TEST_RW	Read/write test parameter - used only for conformance testing.
09	DD_RESOURCE	String identifying the tag of the resource which contains the Device Description for the resource.
10	MANUFAC_ID	Manufacturer identification number - used by an interface device to locate the DD file for the resource.
11	DEV_TYPE	Manufacturer's model number associated with the resource - used by interface devices to locate the DD file for the resource.
12	DEV_REV	Manufacturer revision number associated with the resource - used by an interface device to locate the DD file for the resource.
13	DD_REV	Revision of the DD associated with the resource - used by the interface device to locate the DD file for the resource.
14	GRANT_DENY	Options for controlling access of host computer and local control panels to operating, tuning and alarm parameters of the block.
15	HARD_TYPES	The types of hardware available as channel numbers. The supported hardware type is: SCALAR_INPUT

Table 3-2: Resource block parameters (continued)

Number	Parameter	Description
16	RESTART	Allows a manual restart to be initiated. 1) Run: This is passive state of this parameter. 2) Restart resource: To clear up the problems like garbage collection. 3) Restart with defaults: reset all configurable function block application objects to their initial value i.e. their value before any configuration was done by the user. This will also remove appended serial numbers of function block tags 4) Restart processor: provides a way to hit the reset button on the processor associated with the resource. 5) Restart to append serial number: Appends serial number to function block tags. 11) Restart default blocks: defaults manufacturer pre-instantiated blocks.
17	FEATURES	Used to show supported resource block options. The supported features are: SOFT_WRITE_LOCK_SUPPORT, HARD_WRITE_LOCK_SUPPORT, REPORTS, UNICODE, MULTI_BIT_ALARM_SUPPORT and FB_ACTION_RESTART_RELINK
18	FEATURE_SEL	Used to select resource block options.
19	CYCLE_TYPE	Identifies the block execution methods available for this resource. The supported cycle types are: SCHEDULED, and COMPLETION_OF_BLOCK_EXECUTION
20	CYCLE_SEL	Used to select the block execution method for this resource.
21	MIN_CYCLE_T	Time duration of the shortest cycle interval of which the resource is capable.
22	MEMORY_SIZE	Available configuration memory in the empty resource. To be checked before attempting a download.
23	NV_CYCLE_T	Minimum time interval specified by the manufacturer for writing copies of NV parameters to non-volatile memory. Zero means it will never be automatically copied. At the end of NV_CYCLE_T, only those parameters which have changed need to be updated in NVRAM.
24	FREE_SPACE	Percent of memory available for further configuration. Zero in preconfigured resource.
25	FREE_TIME	Percent of the block processing time that is free to process additional blocks.
26	SHED_RCAS	Time duration at which to give up on computer writes to function block RCas locations. Shed from RCas will never happen when SHED_RCAS = 0.
27	SHED_ROUT	Time duration at which to give up on computer writes to function block ROut locations. Shed from ROut will never happen when SHED_ROUT = 0.
28	FAULT_STATE	Condition set by loss of communication to an output block, fault promoted to an output block or physical contact. When FAIL_SAFE condition is set, then output function blocks will perform their FAIL_SAFE actions.
29	SET_FSTATE	Allows the FAIL_SAFE condition to be manually initiated by selecting Set.
30	CLR_FSTATE	Writing a Clear to this parameter will clear the device FAIL_SAFE if the field condition has cleared.
31	MAX_NOTIFY	Maximum number of unconfirmed notify messages possible.

Table 3-2: Resource block parameters (continued)

Number	Parameter	Description
32	LIM_NOTIFY	Maximum number of unconfirmed alert notify messages allowed.
33	CONFIRM_TIME	The time the resource will wait for confirmation of receipt of a report before trying again. Retry will not happen when CONFIRM_TIME=0.
34	WRITE_LOCK	If set, all writes to static and non-volatile parameters are prohibited, except to clear WRITE_LOCK. Block inputs will continue to be updated.
35	UPDATE_EVT	This alert is generated by any change to the static data.
36	BLOCK_ALM	The BLOCK_ALM is used for all configuration, hardware, connection failure or system problems in the block. The cause of the alert is entered in the subcode field. The first alert to become active will set the Active status in the Status attribute. As soon as the Unreported status is cleared by the alert reporting task, another block alert may be reported without clearing the Active status, if the subcode has changed.
37	ALARM_SUM	The current alert status, unacknowledged states, unreported states, and disabled states of the alarms associated with the function block.
38	ACK_OPTION	Selection of whether alarms associated with the block will be automatically acknowledged.
39	WRITE_PRI	Priority of the alarm generated by clearing the write lock.
40	WRITE_ALM	This alert is generated if the write lock parameter is cleared.
41	ITK_VER	Major revision number of the interoperability test case used in certifying this device as interoperable. The format and range are controlled by the fieldbus.
42	FD_VER	This parameter's value equals the value of the major version of the Field Diagnostics specification that this device was designed to.
43	FD_FAIL_ACTIVE	Reflects the error conditions that are being detected as active as selected for this category. It is a bit string, so that multiple conditions may be shown.
44	FD_OFFSPEC_ACTIVE	Reflects the error conditions that are being detected as active as selected for this category. It is a bit string, so that multiple conditions may be shown.
45	FD_MAINT_ACTIVE	Reflects the error conditions that are being detected as active as selected for this category. It is a bit string, so that multiple conditions may be shown.
46	FD_CHECK_ACTIVE	Reflects the error conditions that are being detected as active as selected for this category. It is a bit string, so that multiple conditions may be shown.
47	FD_FAIL_MAP	Maps conditions to be detected as active for this alarm category. Thus the same condition may be active in all, some, or none of the four alarm categories.
48	FD_OFFSPEC_MAP	Maps conditions to be detected as active for this alarm category. Thus the same condition may be active in all, some, or none of the four alarm categories.
49	FD_MAINT_MAP	Maps conditions to be detected as active for this alarm category. Thus the same condition may be active in all, some, or none of the four alarm categories.
50	FD_CHECK_MAP	Maps conditions to be detected as active for this alarm category. Thus the same condition may be active in all, some, or none of the four alarm categories.

Table 3-2: Resource block parameters (continued)

Number	Parameter	Description
51	FD_FAIL_MASK	Allows the user to suppress any single or multiple conditions that are active, in this category, from being broadcast to the host through the alarm parameter. A bit equal to '1' will mask i.e. inhibit the broadcast of a condition, and a bit equal to '0' will unmask i.e. allow broadcast of a condition.
52	FD_OFFSPEC_MASK	Allows the user to suppress any single or multiple conditions that are active, in this category, from being broadcast to the host through the alarm parameter. A bit equal to '1' will mask i.e. inhibit the broadcast of a condition, and a bit equal to '0' will unmask i.e. allow broadcast of a condition.
53	FD_MAINT_MASK	Allows the user to suppress any single or multiple conditions that are active, in this category, from being broadcast to the host through the alarm parameter. A bit equal to '1' will mask i.e. inhibit the broadcast of a condition, and a bit equal to '0' will unmask i.e. allow broadcast of a condition.
54	FD_CHECK_MASK	Allows the user to suppress any single or multiple conditions that are active, in this category, from being broadcast to the host through the alarm parameter. A bit equal to '1' will mask i.e. inhibit the broadcast of a condition, and a bit equal to '0' will unmask i.e. allow broadcast of a condition.
55	FD_FAIL_ALM	Used primarily to broadcast a change in the associated active conditions, which are not masked, for this alarm category to a Host System.
56	FD_OFFSPEC_ALM	Used primarily to broadcast a change in the associated active conditions, which are not masked, for this alarm category to a Host System.
57	FD_MAINT_ALM	Used primarily to broadcast a change in the associated active conditions, which are not masked, for this alarm category to a Host System.
58	FD_CHECK_ALM	Used primarily to broadcast a change in the associated active conditions, which are not masked, for this alarm category to a Host System.
59	FD_FAIL_PRI	Allows the user to specify the priority of this alarm category.
60	FD_OFFSPEC_PRI	Allows the user to specify the priority of this alarm category.
61	FD_MAINT_PRI	Allows the user to specify the priority of this alarm category.
62	FD_CHECK_PRI	Allows the user to specify the priority of this alarm category.
63	FD_SIMULATE	Allows the conditions to be manually supplied when simulation is enabled. When simulation is disabled both the diagnostic simulate value and the diagnostic value track the actual conditions. The simulate jumper is required for simulation to be enabled and while simulation is enabled the recommended action will show that simulation is active.
64	FD_RECOMMEN_ACT	A device enumerated summarization of the most severe condition or conditions detected. The DD help should describe by enumerated action, what should be done to alleviate the condition or conditions. 0 is defined as Not Initialized, 1 is defined as No Action Required, all others defined by manufacturer.
65	FD_EXTENDED_ACTIVE_1	An optional parameter or parameters to allow the user finer detail on conditions causing an active condition in the FD_*_ACTIVE parameters.

Table 3-2: Resource block parameters (continued)

Number	Parameter	Description
66	FD_EXTENDED_MAP_1	An optional parameter or parameters to allow the user finer control on enabling conditions contributing to the conditions in FD_*_ACTIVE parameters.
67	COMPATIBILITY_REV	Optionally used when replacing field devices. The correct usage of this parameter presumes the COMPATIBILITY_REV value of the replacing device should be equal or lower than the DEV_REV value of the replaced device.
68	HARDWARE_REVISION	Manufacturer hardware revision
69	SOFTWARE_REV	Manufacturer hardware revision
70	PD_TAG	PD tag description of device
71	DEV_STRING	Used to load new licensing into the device. The value can be written but will always read back with a value of 0.
72	DEV_OPTIONS	Indicates which miscellaneous and diagnostic device licensing options are enabled. It also indicates Transducer options.
73	OUTPUT_BOARD_SN	Output board serial number
74	FINAL_ASSY_NUM	Same final assembly number placed on the neck label
75	DOWNLOAD_MODE	Gives access to the boot block code for over the wire downloads
76	HEALTH_INDEX	Parameter shall be set based on the active FD alarms or PWA alarms. HEALTH_INDEX will show 100 if target mode of block is OOS or there are no active alarms in device. The table below represents HEALTH_INDEX value when FD or PWA alarms are active in a device.
77	FAILED_PRI	Designates the alarming priority of the FAILED_ALM and also used as switch b/w FD and legacy PWA. If value is greater than or equal to 1 then PWA alerts will be active in device else device will have FD alerts.
78	RECOMMENDED_ACTION	Enumerated list of recommended actions displayed with a device alert
79	FAILED_ALM	Alarm indicating a failure within a device which makes the device non-operational
80	MAINT_ALM	Alarm indicating the device needs maintenance soon. If the condition is ignored, the device will eventually fail.
81	ADVISE_ALM	Alarm indicating advisory alarms. These conditions do not have a direct impact on the process or device integrity.
82	FAILED_ENABLE	Enabled FAILED_ALM alarm conditions. Corresponds bit for bit to the FAILED_ACTIVE. A bit on means that the corresponding alarm condition is enabled and will be detected. A bit off means the corresponding alarm condition is disabled and will not be detected. This parameter is the Read Only copy of FD_FAIL_MAP.
83	FAILED_MASK	Mask of Failure Alarm. Corresponds bit for bit to the FAILED_ACTIVE. A bit on means that the failure is masked out from alarming. This parameter is the Read Only copy of FD_FAIL_MASK.

Table 3-2: Resource block parameters (continued)

Number	Parameter	Description
84	FAILED_ACTIVE	Enumerated list of failure conditions within a device. All open bits are free to be used as appropriate for each specific device. This parameter is the Read Only copy of FD_FAIL_ACTIVE.
85	MAINT_PRI	Designates the alarming priority of the MAINT_ALM
86	MAINT_ENABLE	Enabled MAINT_ALM alarm conditions. Corresponds bit for bit to the MAINT_ACTIVE. A bit on means that the corresponding alarm condition is enabled and will be detected. A bit off means the corresponding alarm condition is disabled and will not be detected. This parameter is the Read Only copy of FD_OFFSPEC_MAP.
87	MAINT_MASK	Mask of Maintenance Alarm. Corresponds bit for bit to the MAINT_ACTIVE. A bit on means that the failure is masked out from alarming. This parameter is the Read Only copy of FD_OFFSPEC_MASK.
88	MAINT_ACTIVE	Enumerated list of maintenance conditions within a device. All open bits are free to be used as appropriate for each specific device. This parameter is the Read Only copy of FD_OFFSPEC_ACTIVE.
89	ADVISE_PRI	Designates the alarming priority of the ADVISE_ALM
90	ADVISE_ENABLE	Enabled ADVISE_ALM alarm conditions. Corresponds bit for bit to the ADVISE_ACTIVE. A bit on means that the corresponding alarm condition is enabled and will be detected. A bit off means the corresponding alarm condition is disabled and will not be detected. This parameter is the Read Only copy of FD_MAINT_MAP & FD_CHECK_MAP.
91	ADVISE_MASK	Mask of Advisory Alarm. Corresponds bit for bit to the ADVISE_ACTIVE. A bit on means that the failure is masked out from alarming. This parameter is the Read Only copy of FD_MAINT_MASK & FD_CHECK_MASK.
92	ADVISE_ACTIVE	Enumerated list of advisory conditions within a device. All open bits are free to be used as appropriate for each specific device. This parameter is the Read Only copy of FD_MAINT_ACTIVE & FD_CHECK_ACTIVE.

Block errors

The table below lists conditions reported in the BLOCK_ERR parameter.

Table 3-3: BLOCK_ERR conditions

Number	Name and description
0	Other
1	Block Configuration Error: A feature in CYCLE_SEL is set that is not supported by CYCLE_TYPE.
3	Simulate Active: This indicates that the simulation jumper is in place. This is not an indication that the I/O blocks are using simulated data.
6	Device needs maintenance soon
7	Input failure/process variable has bad status
9	Memory Failure: A memory failure has occurred in FLASH, RAM, or EEPROM memory.
10	Lost Static Data: Static data that is stored in non-volatile memory has been lost.

Table 3-3: BLOCK_ERR conditions (continued)

Number	Name and description
11	Lost NV Data: Non-volatile data that is stored in non-volatile memory has been lost.
13	Device Needs Maintenance Now
14	Power Up: The device was just powered-up.
15	OOS: The actual mode is out of service.

Modes

The resource block supports two modes of operation as defined by the MODE_BLK parameter:

Automatic (Auto) The block is processing its normal background memory checks.

Out of service (OOS) The block is not processing its tasks. When the resource block is in OOS, all blocks within the resource (device) are forced into OOS. The BLOCK_ERR parameter shows Out of Service. In this mode, changes can be made to all configurable parameters. The target mode of a block may be restricted to one or more of the supported modes.

Alarm detection

A block alarm will be generated whenever the BLOCK_ERR has an error bit set. The types of block error for the resource block are defined above. A write alarm is generated whenever the WRITE_LOCK parameter is cleared. The priority of the write alarm is set in the following parameter:

- WRITE_PRI

Table 3-4: Alarm Priority Levels

Number	Description
0	The priority of an alarm condition changes to 0 after the condition that caused the alarm is corrected.
1	An alarm condition with a priority of 1 is recognized by the system, but is not reported to the operator.
2	An alarm condition with a priority of 2 is reported to the operator, but does not require operator attention (such as diagnostics and system alerts).
3-7	Alarm conditions of priority 3 to 7 are advisory alarms of increasing priority.
8-15	Alarm conditions of priority 8 to 15 are critical alarms of increasing priority.

Status handling

There are no status parameters associated with the resource block.

3.10.2 Field Diagnostics & PlantWeb Alerts

The Rosemount™ 848T ITK6 has two mechanisms for alarms, one is Field Diagnostics (FD) and other is PlantWeb Alerts (PWA) for backward compatibility only.

The flexible capability has been added to allow user to select any alarm to be in the PWA FAILED/FD FAILED group or PWA MAINTENANCE/FD OFFSPEC group or PWA ADVISE/FD MAINTENANCE group or PWA ADVISE/FD CHECK group.

In PlantWeb Alerts, the alarms can be represented in three groups i.e. FAILED, MAINT & ADVISE. In Field Diagnostic, the alarms can be represented in four groups i.e. FAILED, OFFSPEC, MAINT & CHECK.

Parameter FAILED_PRI is used as a switch for using Field Diagnostic and PlantWeb Alerts.

Use the Field Diagnostic Alarm

If FAILED_PRI is equal to 0, Field Diagnostic alarms are supported and Plantweb™ alarms are not. Field Diagnostic functionality includes four different Field Diagnostic Alarms such as FD_FAIL_ALM, FD_OFFSPEC_ALM, FD_MAINT_ALM and FD_CHECK_ALM. For these alarms, there are corresponding alarm priority parameter, masking parameter alarm active and alarm mapping parameter such as FD_*_PRI, FD_*_MASK & FD_*_ACTIVE & FD_*_MAP.

Use the PlantWeb Alarm

If FAILED_PRI is greater than 0, Plantweb alarms are supported and Field Diagnostic are not. Plantweb functionality includes three different PlantWeb Alarms FAILED_ALM, MAINT_ALM and ADVISE_ALM. For PlantWeb Alerts, there are corresponding alarm masking parameter, alarm active parameter and alarm mapping parameter such as *_MASK, *_ACTIVE & *_ENABLE. These parameters have read-only access and are duplicated from corresponding FD parameters.

So for example, in case of PWA alarms, if user wishes to change the mapping of any PlantWeb Alerts then the new value is written to the corresponding FD_*_MAP parameter. *_ENABLE shall reflect whatever is being written to FD_*_MAP parameter. The same applies for *_MASK parameters.

Note

Here * implies all four categories of FD alerts for e.g. FD_*_ACTIVE resembles FD_FAIL_ACTIVE, FD_OFFSPEC_ACTIVE, FD_MAINT_ACTIVE & FD_CHECK_ACTIVE. The similar notation is also applicable for PWA alarms for e.g. FD_*_ACTIVE resembles FAIL_ACTIVE, MAINT_ACTIVE & ADVISE_ACTIVE.

3.10.3 Plantweb alerts

The alerts and recommended actions should be used in conjunction with [Operation and maintenance](#).

The Resource Block will act as a coordinator for Plantweb alerts. There will be three alarm parameters (FAILED_ALARM, MAINT_ALARM, and ADVISE_ALARM) which will contain information regarding some of the device errors which are detected by the transmitter software. There will be a RECOMMENDED_ACTION parameter which will be used to display the recommended action text for the highest priority alarm and a HEALTH_INDEX parameters (0 - 100) indicating the overall health of the transmitter. FAILED_ALARM will have the highest priority followed by MAINT_ALARM and ADVISE_ALARM will be the lowest priority.

FAILED_ALARMS

A failure alarm indicates a failure within a device that will make the device or some part of the device non-operational. This implies that the device is in need of repair and must be fixed immediately. There are five parameters associated with FAILED_ALARMS specifically, they are described below.

FAILED_ENABLED

This parameter contains a list of failures in the device which makes the device non-operational that will cause an alert to be sent. Below is a list of the failures with the highest priority first.

Table 3-5: Failure alarms

Alarm	Priority
ASIC Failure	1

Table 3-5: Failure alarms (continued)

Alarm	Priority
Electronics Failure	2
Hardware/Software Incompatible	3
Memory Failure	4
Body Temperature Failure	5
Sensor 1 Failure	6
Sensor 2 Failure	7
Sensor 3 Failure	8
Sensor 4 Failure	9
Sensor 5 Failure	10
Sensor 6 Failure	11
Sensor 7 Failure	12
Sensor 8 Failure	13

FAILED_MASK

This parameter will mask any of the failed conditions listed in FAILED_ENABLED. A bit on means that the condition is masked out from alarming and will not be reported.

FAILED_PRI

Designates the alerting priority of the FAILED_ALM, see [Table 3-4](#). The default is 0 and the recommended value are between 8 and 15.

FAILED_ACTIVE

This parameter displays which of the alarms is active. Only the alarm with the highest priority will be displayed. This priority is not the same as the FAILED_PRI parameter described above. This priority is hard coded within the device and is not user configurable.

FAILED_ALM

Alarm indicating a failure within a device which makes the device non-operational.

MAINT_ALARMS

A maintenance alarm indicates the device or some part of the device needs maintenance soon. If the condition is ignored, the device will eventually fail. There are five parameters associated with MAINT_ALARMS, they are described below.

MAINT_ENABLED

The MAINT_ENABLED parameter contains a list of conditions indicating the device or some part of the device needs maintenance soon.

Table 3-6: Maintenance alarms/priority alarm

Alarm	Priority
CJC Degraded	1

Table 3-6: Maintenance alarms/priority alarm (continued)

Alarm	Priority
Body Temperature Out of Range	2
Sensor 1 Degraded	3
Sensor 2 Degraded	4
Sensor 3 Degraded	5
Sensor 4 Degraded	6
Sensor 5 Degraded	7
Sensor 6 Degraded	8
Sensor 7 Degraded	9
Sensor 8 Degraded	10

MAINT_MASK

The MAINT_MASK parameter will mask any of the failed conditions listed in MAINT_ENABLED. A bit on means that the condition is masked out from alarming and will not be reported.

MAINT_PRI

MAINT_PRI designates the alarming priority of the MAINT_ALM, [Table 3-4](#). The default is 0 and the recommended values is 3 to 7.

MAINT_ACTIVE

The MAINT_ACTIVE parameter displays which of the alarms is active. Only the condition with the highest priority will be displayed. This priority is not the same as the MAINT_PRI parameter described above. This priority is hard coded within the device and is not user configurable.

MAINT_ALM

An alarm indicating the device needs maintenance soon. If the condition is ignored, the device will eventually fail.

Advisory alarms

An advisory alarm indicates informative conditions that do not have a direct impact on the device's primary functions. There are five parameters associated with ADVISE_ALARMS, they are described below.

ADVISE_ENABLED

The ADVISE_ENABLED parameter contains a list of informative conditions that do not have a direct impact on the device's primary functions. Below is a list of the advisories with the highest priority first.

Alarm	Priority
Excessive Deviation	1
Excessive Rate of Change	2
Check	3

Note

Alarms are only prioritized if Multi-Bit Alerts are disabled. If MBA is enabled, all alerts are visible.

ADVISE_MASK

The ADVISE_MASK parameter will mask any of the failed conditions listed in ADVISE_ENABLED. A bit on means the condition is masked out from alarming and will not be reported.

ADVISE_PRI

ADVISE_PRI designates the alarming priority of the ADVISE_ALM, see Table 3-4. The default is 0 and the recommended values are 1 or 2.

ADVISE_ACTIVE

The ADVISE_ACTIVE parameter displays which of the advisories is active. Only the advisory with the highest priority will be displayed. This priority is not the same as the ADVISE_PRI parameter described above. This priority is hard coded within the device and is not user configurable.

ADVISE_ALM

ADVISE_ALM is an alarm indicating advisory alarms. These conditions do not have a direct impact on the process or device integrity.

3.10.4 Recommended actions for Plantweb alerts

RECOMMENDED_ACTION

The RECOMMENDED_ACTION parameter displays a text string that will give a recommended course of action to take based on which type and which specific event of the Plantweb alerts are active.

Table 3-7: RB.RECOMMENDED_ACTION

Alarm type	Active event	Recommended action
None	None	No action required
Advisory	Excessive Deviation	Verify the process temperature, sensor wiring, and check sensor integrity.
Advisory	Excessive Rate of Change	Verify sensor wiring is appropriate in each junction point and check sensor integrity.
Maintenance	CJC Degraded	If T/C sensors are being used, restart the device. If condition persists, replace the device.
Maintenance	Body Temperature Out of Range	Verify the ambient temperature is within operating limits.
Maintenance	Sensor 1 Degraded	Confirm the operating range of Sensor 1 and/or verify the sensor connection and device environment.
Maintenance	Sensor 2 Degraded	Confirm the operating range of Sensor 2 and/or verify the sensor connection and device environment.
Maintenance	Sensor 3 Degraded	Confirm the operating range of Sensor 3 and/or verify the sensor connection and device environment.
Maintenance	Sensor 4 Degraded	Confirm the operating range of Sensor 4 and/or verify the sensor connection and device environment.

Table 3-7: RB.RECOMMENDED_ACTION (continued)

Alarm type	Active event	Recommended action
Maintenance	Sensor 5 Degraded	Confirm the operating range of Sensor 5 and/or verify the sensor connection and device environment.
Maintenance	Sensor 6 Degraded	Confirm the operating range of Sensor 6 and/or verify the sensor connection and device environment.
Maintenance	Sensor 7 Degraded	Conform the operating range of Sensor 7 and/or verify the sensor connection and device environment.
Maintenance	Sensor 8 Degraded	Confirm the operating range of Sensor 8 and/or verify the sensor connection and device environment.
Failed	Sensor 1 Failure	Verify the Sensor 1 Instrument process is within the Sensor range and/or confirm sensor configuration and wiring.
Failed	Sensor 2 Failure	Verify the Sensor 2 Instrument process is within the Sensor range and/or confirm sensor configuration and wiring.
Failed	Sensor 3 Failure	Verify the Sensor 3 Instrument process is within the Sensor range and/or confirm sensor configuration and wiring.
Failed	Sensor 4 Failure	Verify the Sensor 4 Instrument process is within the Sensor range and/or confirm sensor configuration and wiring.
Failed	Sensor 5 Failure	Verify the Sensor 5 Instrument process is within the Sensor range and/or confirm sensor configuration and wiring.
Failed	Sensor 6 Failure	Verify the Sensor 6 Instrument process is within the Sensor range and/or confirm sensor configuration and wiring.
Failed	Sensor 7 Failure	Verify the Sensor 7 Instrument process is within the Sensor range and/or confirm sensor configuration and wiring.
Failed	Sensor 8 Failure	Verify the Sensor 8 Instrument process is within the Sensor range and/or confirm sensor configuration and wiring.
Failed	Body Temperature Failure	Verify the ambient temperature is within the operating limits of this device. If condition persists, replace the device.
Failed	Hardware/Software Incompatible	Contact Service Center to verify the Device Information (RESOURCE.HARDWARE_REV, AND RESOURCE.RB_SFTWR_REV_ALL).
Failed	Memory Error	Restart the transmitter by writing the RESTART parameter to 4 - Restart Processor. If condition persists, replace the transmitter.
Failed	Electronics Failure	Electronics failure has occurred. Restart the transmitter. If condition persists, replace the transmitter.
Failed	ASIC Failure	ASIC failure has occurred. Restart the transmitter. If condition persists, replace the transmitter.

Note

If status is set up to flag failure/warning you will see associated sensor degraded or failure alert.

3.10.5 Field Diagnostics Alerts

The Resource Block will act as a coordinator for Field Diagnostic Alerts. There will be four alarm parameters (FD_FAILED_ALARM, FD_OFFSPEC_ALARM, FD_MAINT_ALARM, and FD_CHECK_ALARM) that will contain information regarding some of the device errors that are detected by the transmitter software. There will be a RECOMMENDED_ACTION parameter that will be used to display the recommended action text for the highest priority alarm and a HEALTH_INDEX parameters (0 - 100) indicating the overall health of the transmitter. FD_FAILED_ALARM will have the highest priority followed by FD_OFFSPEC_ALARM, FD_MAINT_ALARM and FD_CHECK_ALARM will be the lowest priority.

FD failed alarms

A failure alarm indicates a failure within a device that will make the device or some part of the device non-operational. This implies that the device is in need of repair and must be fixed immediately. There are five parameters associated with FD_FAILED_ALARMS specifically, they are described below.

FD_FAILED_MAP

FD_FAIL_MAP parameter maps conditions to be detected as active for FD_FAIL_ALARM category. Thus the same condition may be active in all, some, or none of the 4 alarm categories. Below is a list of the failures with the highest priority first.

Table 3-8: FD Failure Alarms

Alarm	Priority
ASIC Failure	1
Electronics Failure	2
Hardware/Software Incompatible	3
Memory Failure	4
Body Temperature Failure	5
Sensor 1 Failure	6
Sensor 2 Failure	7
Sensor 3 Failure	8
Sensor 4 Failure	9
Sensor 5 Failure	10
Sensor 6 Failure	11
Sensor 7 Failure	12
Sensor 8 Failure	13

FD_FAILED_MASK

FD_FAIL_MASK parameter will mask any of the failed conditions listed in FD_FAILED_MAP. A bit on means the condition is masked out from alarming and will not be reported.

FD_FAILED_PRI

Designates the alerting priority of the FD_FAILED_ALM, see [Table 3-4](#). The default is 0 and the recommended value are between 8 and 15.

FD_FAILED_ACTIVE

FD_FAIL_ACTIVE parameter displays the active alarms is active that are being selected for this category. Only the alarm with the highest priority will be displayed. This priority is not the same as the FD_FAILED_PRI parameter described above. This priority is hard coded within the device and is not user configurable.

FD_FAILED_ALM

FD_FAIL_ALM indicates a failure within a device which makes the device non-operational. FD_FAIL_ALM parameter is used primarily to broadcast a change in the associated active conditions, which are not masked, for this alarm category to a Host System.

FD OFFSPEC ALARMS

An offspec alarm indicates that the device or some part of the device needs maintenance soon, if the condition is ignored the device will eventually fail. There are five parameters associated with FD OFFSPEC ALARMS, they are described below.

FD_OFFSPEC_MAP

FD_OFFSPEC_MAP parameter maps conditions to be detected as active for FD_OFFSPEC_ALARM category. Thus the same condition may be active in all, some, or none of the 4 alarm categories. Below is a list of the failures with the highest priority first.

Table 3-9: FD Offspec alarms

Alarm	Priority
CJC Degraded	1
Body Temperature Out of Range	2
Sensor 1 Degraded	3
Sensor 2 Degraded	4
Sensor 3 Degraded	5
Sensor 4 Degraded	6
Sensor 5 Degraded	7
Sensor 6 Degraded	8
Sensor 7 Degraded	9
Sensor 8 Degraded	10

FD_OFFSPEC_MASK

The FD_OFFSPEC_MASK parameter will mask any of the failed conditions listed in FD_OFFSPEC_MAP. A bit on means the condition is masked out from alarming and will not be reported.

FD_OFFSPEC_PRI

FD_OFFSPEC_PRI designates the alarming priority of the FD_OFFSPEC_ALM, see [Table 3-4](#). The default is 0 and the recommended values are 3 to 7.

FD_OFFSPEC_ACTIVE

FD_OFFSPEC_ACTIVE parameter displays the active alarms is active that are being selected for this category. Only the alarm with the highest priority will be displayed. This priority is not the same as the FD_OFFSPEC_PRI parameter described above. This priority is hard coded within the device and is not user configurable.

FD_OFFSPEC_ALM

An alarm indicating the device needs maintenance soon. If the condition is ignored, the device will eventually fail. FD_OFFSPEC_ALM parameter is used primarily to broadcast a change in the associated active conditions, which are not masked, for this alarm category to a Host System.

FD MAINT ALARMS

A maintenance alarm indicates informative conditions that do not have a direct impact on the device's primary function(s). There are five parameters associated with MAINT_ALARMS, they are described below.

FD_MAINT_MAP

The FD_MAINT_MAP parameter contains a list of conditions that do not have a direct impact on the device's primary function(s).

Table 3-10: Maintenance Alarms/Priority Alarm

Alarm	Priority
Excessive Deviation	1
Excessive Rate of Change	2

FD_MAINT_MASK

The FD_MAINT_MASK parameter will mask any of the failed conditions listed in FD_MAINT_ENABLED. A bit on means that the condition is masked out from alarming and will not be reported.

FD_MAINT_PRI

FD_MAINT_PRI designates the alarming priority of the MAINT_ALM, [Table 3-4](#). The default is 0 and the recommended value is greater than 2.

FD_MAINT_ACTIVE

FD_MAINT_ACTIVE parameter displays the active alarms is active that are being selected for this category. Only the alarm with the highest priority will be displayed. This priority is not the same as the FD_MAINT_PRI parameter described above. This priority is hard coded within the device and is not user configurable.

FD_MAINT_ALM

FD_MAINT_ALM indicates advisory alarms. These conditions do not have a direct impact on the process or device integrity.

FD Check Alarms

An advisory alarm indicates informative conditions that do not have a direct impact on the device's primary functions. There are five parameters associated with ADVISE_ALARMS, they are described below.

FD_CHECK_MAP

The FD_CHECK_MAP parameter contains a list of informative conditions that do not have a direct impact on the device's primary functions. Below is a list of the advisories with the highest priority first.

Table 3-11: Check Alarms

Alarm	Priority
Check	1

FD_CHECK_MASK

The `FD_CHECK_MASK` parameter will mask any of the failed conditions listed in `FD_CHECK_MAP`. A bit on means the condition is masked out from alarming and will not be reported.

`FD_CHECK_PRI`

`FD_CHECK_PRI` designates the alarming priority of the `ADVISE_ALM`, see [Table 3-4](#). The default is 0 and the recommended values is 1.

`FD_CHECK_ACTIVE`

The `FD_CHECK_ACTIVE` parameter displays which of the advisories is active. Only the advisory with the highest priority will be displayed. This priority is not the same as the `FD_CHECK_PRI` parameter described above. This priority is hard coded within the device and is not user configurable.

`FD_CHECK_ALM`

`FD_CHECK_ALM` is an alarm indicating advisory alarms. These conditions do not have a direct impact on the process or device integrity.

3.10.6 Recommended actions for field diagnostics alerts

`RECOMMENDED_ACTION`

The `RECOMMENDED_ACTION` parameter displays a text string that will give a recommended course of action to take based on which type and which specific event of the Field Diagnostics alerts are active.

Table 3-12: RB.RECOMMENDED_ACTION

Alarm type	Active event	Recommended action
None	None	No action required
Failed	ASIC Failure	ASIC Failure has occurred. Restart the transmitter. If condition persists, replace the transmitter
Failed	Electronics Failure	Electronics Failure has occurred. Restart the transmitter. If condition persists, replace the transmitter.
Failed	Hardware/Software Incompatible	Contact a Service Center and verify the Device Information (<code>RESOURCE.HARDWARE_REV</code> and <code>RESOURCE.RB_SFTWR_REV</code>)
Failed	Memory Failure	Restart the transmitter by writing the <code>RESTART</code> parameter to 4 - Restart Processor. If condition persists, replace the transmitter.
Failed	Body Temperature Failure	Verify the ambient temperature is within the operating limits of this device. If condition persists, replace the device
Failed	Sensor 1 Failure	Verify the Instrument process for Sensor 1 is within the Sensor range and/or confirm sensor configuration and wiring.
Failed	Sensor 2 Failure	Verify the Instrument process for Sensor 2 is within the Sensor range and/or confirm sensor configuration and wiring.
Failed	Sensor 3 Failure	Verify the Instrument process for Sensor 3 is within the Sensor range and/or confirm sensor configuration and wiring.
Failed	Sensor 4 Failure	Verify the Instrument process for Sensor 4 is within the Sensor range and/or confirm sensor configuration and wiring.
Failed	Sensor 5 Failure	Verify the Instrument process for Sensor 5 is within the Sensor range and/or confirm sensor configuration and wiring.

Table 3-12: RB.RECOMMENDED_ACTION (continued)

Alarm type	Active event	Recommended action
Failed	Sensor 6 Failure	Verify the Instrument process for Sensor 6 is within the Sensor range and/or confirm sensor configuration and wiring.
Failed	Sensor 7 Failure	Verify the Instrument process for Sensor 7 is within the Sensor range and/or confirm sensor configuration and wiring.
Failed	Sensor 8 Failure	Verify the Instrument process for Sensor 8 is within the Sensor range and/or confirm sensor configuration and wiring.
Off Spec	CJC Degraded	If T/C sensors are being used, restart the device. If condition persists, replace the device.
Off Spec	Body Temperature Out of Range	Verify the ambient temperature is within operating limits
Off Spec	Sensor 1 Degraded	Confirm the operating range of Sensor 1 and/or verify the sensor connection and device environment.
Off Spec	Sensor 2 Degraded	Confirm the operating range of Sensor 2 and/or verify the sensor connection and device environment.
Off Spec	Sensor 3 Degraded	Confirm the operating range of Sensor 3 and/or verify the sensor connection and device environment.
Off Spec	Sensor 4 Degraded	Confirm the operating range of Sensor 4 and/or verify the sensor connection and device environment.
Off Spec	Sensor 5 Degraded	Confirm the operating range of Sensor 5 and/or verify the sensor connection and device environment.
Off Spec	Sensor 6 Degraded	Confirm the operating range of Sensor 6 and/or verify the sensor connection and device environment.
Off Spec	Sensor 7 Degraded	Confirm the operating range of Sensor 7 and/or verify the sensor connection and device environment.
Off Spec	Sensor 8 Degraded	Confirm the operating range of Sensor 8 and/or verify the sensor connection and device environment.
Maintenance	Excessive Deviation	Verify the process temperature, sensor wiring, and check sensor integrity.
Maintenance	Excessive Rate of Change	Verify sensor wiring is appropriate in each junction point and check sensor integrity
Check	Check	Transducer block under maintenance

3.10.7 Transducer blocks

The transducer block allows the user to view and manage the channel information. There is one transducer block for the eight sensors that contains specific temperature measurement data, including:

- Sensor Type
- Engineering Units
- Damping
- Temperature Compensation

- Diagnostics

Transducer block channel definitions

The Rosemount™ 848T supports multiple sensor inputs. Each input has a channel assigned to it allowing an AI or MAI Function Blocks to be linked to that input. The channels for the 848T are as follows:

Table 3-13: Channel definitions for the Rosemount 848T

Channel	Description	Channel	Description
1	Sensor One	16	Sensor 3 Deviation
2	Sensor Two	17	Sensor 4 Deviation
3	Sensor Three	18	Sensor 5 Deviation
4	Sensor Four	19	Sensor 6 Deviation
5	Sensor Five	20	Sensor 7 Deviation
6	Sensor Six	21	Sensor 8 Deviation
7	Sensor Seven	22	Sensor 1 Rate Change
8	Sensor Eight	23	Sensor 2 Rate Change
9	Differential Sensor 1	24	Sensor 3 Rate Change
10	Differential Sensor 2	25	Sensor 4 Rate Change
11	Differential Sensor 3	26	Sensor 5 Rate Change
12	Differential Sensor 4	27	Sensor 6 Rate Change
13	Body Temperature	28	Sensor 7 Rate Change
14	Sensor 1 Deviation	29	Sensor 8 Rate Change
15	Sensor 2 Deviation		

Figure 3-1: Transducer block data flow

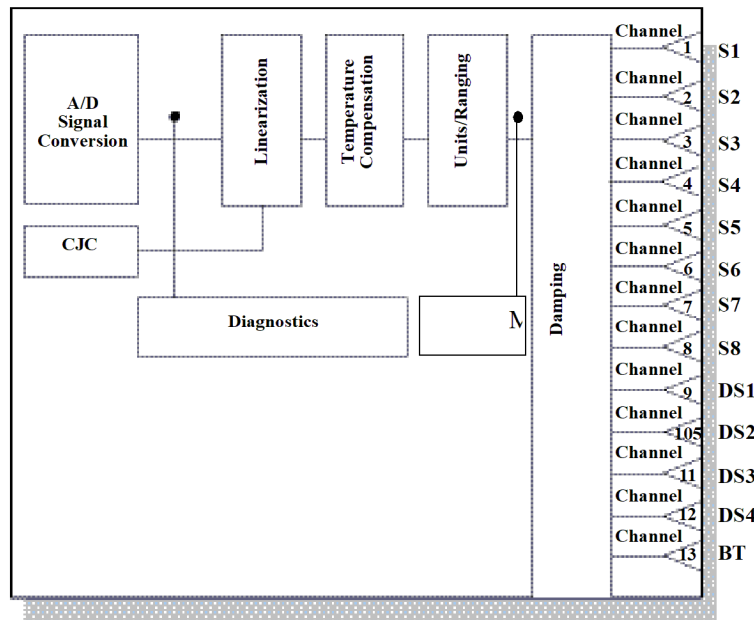

Transducer block errors

The following conditions are reported in the BLOCK_ERR and XD_ERROR parameters.

Table 3-14: Block/Transducer error

Condition number	Name and description
0	Other ⁽¹⁾
7	Input failure/process variable has bad status
15	Out of service: The actual mode is out of service

(1) If BLOCK_ERR is "Other", see XD_ERROR.

Transducer block modes

The transducer block supports two modes of operation as defined by the MODE_BLK parameter.

Automatic (Auto) The block outputs reflect the analog input measurement.

Out of Service (OOS) The block is not processed. Channel outputs are not updated and the status is set to Bad: Out of Service for each channel. The BLOCK_ERR parameter shows Out of Service. In this mode, changes can be made to all configurable parameters. The target mode of a block may be restricted to one or more of the supported modes.

Transducer block alarm detection

Alarms are not generated by the transducer block. By correctly handling the status of the channel values, the down stream block (AI or MAI) will generate the necessary alarms for the measurement. The error that generated this alarm can be determined by looking at BLOCK-ERR and XD_ERROR.

Transducer block status handling

Normally, the status of the output channels reflect the status of the measurement value, the operating condition of the measurement electronics card, and any active alarm conditions. In a transducer, PV reflects the value and status quality of the output channels.

Table 3-15: Transducer block parameters

Number	Parameter	Description
0	BLOCK	N/A
1	ST_REV	The revision level of the static data associated with the function block.
2	TAG_DESC	The user description of the intended application of the block.
3	STRATEGY	The strategy field can be used to identify grouping of blocks.
4	ALERT_KEY	The identification number of the plant unit.
5	MODE_BLK	The actual, target, permitted, and normal modes of the block.
6	BLOCK_ERR	This parameter reflects the error status associated with the hardware or software components associated with a block. Multiple errors may be shown. For a list of enumeration values, see FF-890, Block_Err formal model.
7	UPDATE_EVENT	This alert is generated by any change to the static data.
8	BLOCK_ALM	The BLOCK-ALM is used for all configuration, hardware, connection failure or system problems in the block. The cause of the alert is entered in the subcode field. The first alert to become active will set the Active status in the Status attribute. As soon as the Unreported status is cleared by the alert reporting task, another block alert may be reported without clearing the Active status, if the subcode has changed.
9	TRANSDUCER_DIRECTORY	A directory that specified the number and starting indices of the transducers in the transducer block.
10	TRANSDUCER_TYPE	Identifies the transducer that follows 101 – Standard Temperature with Calibration.
11	XD_ERROR	Provides additional error codes related to transducer blocks. For a list of enumeration values, see FF-902. See tables below for a list of sub-parameters that pertain to XD_ERROR messages.
12	COLLECTION_DIRECTORY	A directory that specifies the number, starting indices, and DD Item ID's of the data collections in each transducer block.
13	SENSOR_1_CONFIG	Sensor Configuration Parameters. See tables below for a list of sub-parameters that pertain to Sensor Configuration functions.
14	PRIMARY_VALUE_1	The measured value and status available to the function block.

Table 3-15: Transducer block parameters (continued)

Number	Parameter	Description
15	SENSOR_2_CONFIG	Sensor Configuration parameters. See tables below for a list of sub-parameters that pertain to Sensor Configuration functions.
16	PRIMARY_VALUE_2	The measured value and status available to the function block.
17	SENSOR_3_CONFIG	Sensor Configuration Parameters. See tables below for a list of sub-parameters that pertain to Sensor Configuration functions.
18	PRIMARY_VALUE_3	The measured value and status available to the function block
19	SENSOR_4_CONFIG	Sensor Configuration Parameters. See tables below for a list of sub-parameters that pertain to Sensor Configuration functions.
20	PRIMARY_VALUE_4	The measured value and status available to the function block.
21	SENSOR_5_CONFIG	Sensor Configuration Parameters. See tables below for a list of sub-parameters that pertain to Sensor Configuration functions.
22	PRIMARY_VALUE_5	The measured value and status available to the function block.
23	SENSOR_6_CONFIG	Sensor Configuration Parameters. See tables below for a list of sub-parameters that pertain to Sensor Configuration functions.
24	PRIMARY_VALUE_6	The measured value and status available to the function block.
25	SENSOR_7_CONFIG	Sensor Configuration Parameters. See tables below for a list of sub-parameters that pertain to Sensor Configuration functions.
26	PRIMARY_VALUE_7	The measured value and status available to the function block.
27	SENSOR_8_CONFIG	Sensor Configuration Parameters. See tables below for a list of sub-parameters that pertain to Sensor Configuration functions.
28	PRIMARY_VALUE_8	The measured value and status available to the function block
29	SENSOR_STATUS	Status of each individual sensor. See tables below for a list of possible status messages.
30	SENSOR_CAL	Parameter structure to allow for calibration of each sensor. See tables below for a list of sub-parameters that pertain to Sensor Calibration functions.
31	CAL_STATUS	Status of the calibration that was previously performed. See tables below for a list of possible Calibration Statuses.

Table 3-15: Transducer block parameters (continued)

Number	Parameter	Description
32	ASIC_REJECTION	A configurable power line noise rejection setting.
33	BODY_TEMP	Body Temperature of the device.
34	BODY_TEMP_RANGE	The range of the body temperature including the units index.
35	TB_SUMMARY_STATUS	Overall summary status of the sensor transducer. See tables below for a list of possible transducer statuses.
36	DUAL_SENSOR_1_CONFIG	Parameter structure to allow for calibration of each differential measurement. See tables below for a list of sub-parameters that pertain to Dual Sensor Calibration functions.
37	DUAL_SENSOR_VALUE_1	The measured value and status available to the function block.
38	DUAL_SENSOR_2_CONFIG	Parameter structure to allow for calibration of each differential measurement. See tables below for a list of sub-parameters that pertain to Dual Sensor Calibration functions.
39	DUAL_SENSOR_VALUE_2	The measured value and status available to the function block.
40	DUAL_SENSOR_3_CONFIG	Parameter structure to allow for calibration of each differential measurement. See tables below for a list of sub-parameters that pertain to Dual Sensor Calibration functions.
41	DUAL_SENSOR_VALUE_3	The measured value and status available to the function block.
42	DUAL_SENSOR_4_CONFIG	Parameter structure to allow for calibration of each differential measurement. See tables below for a list of sub-parameters that pertain to Dual Sensor Calibration functions.
43	DUAL_SENSOR_VALUE_4	The measured value and status available to the function block.
44	DUAL_SENSOR_STATUS	Status of each individual differential measurement. See tables below for a list of possible Dual Sensor statuses.
45	VALIDATION_SNSR1_CONFIG	Validation configuration parameters. See tables below for a list of sub-parameters that pertain to Validation Configuration functions.
46	VALIDATION_SNSR1_VALUES	Validation value parameters. See tables below for a list of sub-parameters that pertain to Validation values.
47	VALIDATION_SNSR2_CONFIG	Validation configuration parameters. See tables below for a list of sub-parameters that pertain to Validation Configuration functions.
48	VALIDATION_SNSR2_VALUES	Validation value parameters. See tables below for a list of sub-parameters that pertain to Validation values.

Table 3-15: Transducer block parameters (continued)

Number	Parameter	Description
49	VALIDATION_SNSR3_CONFIG	Validation configuration parameters. See tables below for a list of sub-parameters that pertain to Validation Configuration functions.
50	VALIDATION_SNSR3_VALUES	Validation value parameters. See tables below for a list of sub-parameters that pertain to Validation values.
51	VALIDATION_SNSR4_CONFIG	Validation configuration parameters. See tables below for a list of sub-parameters that pertain to Validation Configuration functions.
52	VALIDATION_SNSR4_VALUES	Validation value parameters. See tables below for a list of sub-parameters that pertain to Validation values.
53	VALIDATION_SNSR5_CONFIG	Validation configuration parameters. See tables below for a list of sub-parameters that pertain to Validation Configuration functions.
54	VALIDATION_SNSR5_VALUES	Validation value parameters. See tables below for a list of sub-parameters that pertain to Validation values.
55	VALIDATION_SNSR6_CONFIG	Validation configuration parameters. See tables below for a list of sub-parameters that pertain to Validation Configuration functions.
56	VALIDATION_SNSR6_VALUES	Validation value parameters. See tables below for a list of sub-parameters that pertain to Validation values.
57	VALIDATION_SNSR7_CONFIG	Validation configuration parameters. See tables below for a list of sub-parameters that pertain to Validation Configuration functions.
58	VALIDATION_SNSR7_VALUES	Validation value parameters. See tables below for a list of sub-parameters that pertain to Validation values.
59	VALIDATION_SNSR8_CONFIG	Validation configuration parameters. See tables below for a list of sub-parameters that pertain to Validation Configuration functions.
60	VALIDATION_SNSR8_VALUES	Validation value parameters. See tables below for a list of sub-parameters that pertain to Validation values.
61	SENSOR_GRAPH_LIMIT	Sensor graph limit parameters
62	DIFFERENTIAL_GRAPH_LIMIT	Differential graph limit parameters

Change the sensor configuration in the transducer block

If the FOUNDATION Fieldbus configuration tool or host system does not support the use of DD methods for device configuration, the following steps illustrate how to change the sensor configuration in the transducer block.

Procedure

1. Set the MODE_BLK.TARGET to OOS, or set the SENSOR_MODE to configuration.
2. Set SENSOR_n_CONFIG.SENSOR to the appropriate sensor type, and then set SENSOR_n_CONFIG.CONNECTION to the appropriate type and connection.

3. In the Transducer Block, set MODE_BLK.TARGET to AUTO, or set the SENSOR_MODE to operation.

3.10.8 Transducer block sub-parameter tables

Table 3-16: XD_ERROR sub-parameter structure

XD ERROR		Description
0	No Error	N/A
17	General Error	An error has occurred that could not be classified as one of the errors listed below.
18	Calibration Error	An error occurred during calibration of the device or a calibration error has been detected during operation of the device.
19	Configuration Error	An error occurred during configuration of the device or a configuration error has been detected during operation of the device.
20	Electronics Failure	An electronic component has failed.
22	I/O Failure	An I/O failure has occurred.
23	Data Integrity Error	Indicates that data stored within the system may no longer be valid due to non-volatile memory checksum failure, data verify after write failure, etc.
24	Software Error	The software has detected an error. This could be caused by an improper interrupt service routine, an arithmetic overflow, a watchdog timer, etc.
25	Algorithm Error	The algorithm used in the transducer block produced an error. This could be due to an overflow, data reasonableness.

Table 3-17: SENSOR_CONFIG sub-parameter structure

Parameter	Description
SENSOR_MODE	Disables or enables a sensor for configuration
SENSOR_TAG	Sensor description
SERIAL_NUMBER	Serial number for the attached sensor
SENSOR	Sensor Type and Connection (MSB is the sensor type and LSB is the connection)
DAMPING	Sampling Interval used to smooth output using a first order linear filter. A value entered between 0 and the Update_Rate, will result in a damping value equal to the Update_Rate.
INPUT_TRANSIENT_FILTER	Enables or Disables the option for reporting fast changing sensor inputs without temporary holdoff. 0 = Disable, 1 = Enabled
RTD_2_WIRE_OFFSET	User entered value for constant lead-wire resistance correction in a 2-wire RTD and ohm sensor types
ENG_UNITS	The engineering units used for reporting measured sensor values
UPPER_RANGE	The upper sensor limit for the selected sensor is displayed using Units_Index sub parameter.

Table 3-17: SENSOR_CONFIG sub-parameter structure (continued)

Parameter	Description
LOWER_RANGE	The lower sensor limit for the selected sensor is displayed using Units_Index sub parameter.

Table 3-18: SENSOR_STATUS sub-parameter structure

Sensor status table	
0x00	Active
0x01	Out of Service
0x02	Inactive
0x04	Open
0x08	Short
0x10	Out of Range
0x20	Beyond Limits
0x40	Excess EMF Detected
0x80	Other

Table 3-19: SENSOR_CAL sub-parameter structure

Parameter	Description
SENSOR_NUMBER	The sensor number to calibrate
CALIB_POINT_HI	The High calibration point for the selected sensor
CALIB_POINT_LO	The Low calibration point for the selected sensor
CALIB_UNIT	The engineering units used for calibrating the sensor
CALIB_METHOD	The method of the last calibration for sensor 103 - factory trim standard calibration 104 - user trim standard calibration
CALIB_INFO	Information regarding the calibration
CALIB_DATE	Date that the calibration was completed
CALIB_MIN_SPAN	The minimum calibration span value allowed. This minimum span information is necessary to ensure that when calibration is done, the two calibrated points are not too close together
CALIB_PT_HI_LIMIT	The High calibration unit
CALIB_PT_LO_LIMIT	The Low calibration unit

Table 3-20: CAL_STATUS structure

	Cal status
0	No Command Active
1	Command Executing

Table 3-20: CAL_STATUS structure (continued)

	Cal status
2	Command Done
3	Command Done: Errors

Table 3-21: Transducer status sub-parameter structure

	Transducer status table
0x01	A/D Failure
0x02	Sensor Failure
0x04	Dual Sensor Failure
0x08	CJC Degraded
0x10	CJC Failure
0x20	Body Temp Failure
0x40	Sensor Degraded
0x80	Body Temperature Degraded

Table 3-22: DUAL_SENSOR CONFIG sub-parameter structure

Parameter	Description
DUAL_SENSOR_MODE	Disables or enables a sensor for configuration
DUAL_SENSOR_TAG	Differential description
INPUT_A	Sensor to be used in DUAL_SENSOR_CALC
INPUT_B	Sensor to be used in DUAL_SENSOR_CALC
DUAL_SENSOR_CALC	Equation used for the dual sensor measurement including: Not Used, Difference (Input A - Input B), and Absolute Difference (Input A - Input B)
ENG_UNITS	Units used to display sensor parameter
UPPER_RANGE	Upper Differential Limit (Input A High - Input B Low)
LOWER_RANGE	Lower Differential Limit (Input A Low - Input B High)

Table 3-23: DUAL_SENSOR_STATUS sub-parameter structure

	Dual Sensor Status Table
0x00	Active
0x01	Out of Service
0x02	Inactive
0x04	Component Sensor Open
0x08	Component Sensor Short
0x10	Component Sensor Out of Range or Degraded

Table 3-23: DUAL_SENSOR_STATUS sub-parameter structure (continued)

Dual Sensor Status Table	
0x20	Component Sensor Out of Limits
0x40	Component Sensor Inactive
0x80	Configuration Error

Table 3-24: Validation value sub-parameter structure

Validation value sub-parameter structure	
Parameter	Description
VALIDATION_STATUS	State of the channel specific measurement validation measurement
DEVIATION_VALUE	Deviation output value
DEVIATION_STATUS	Status of the deviation output
RATE_OF_CHANGE_VALUE	Rate of change value output
RATE_OF_CHANGE_STATUS	Status of Rate of change output

Table 3-25: Validation Config sub-parameter structure

Parameter	Description
VALIDATION_MODE	Activates the measurement validation data gathering process 0 = Disable 1 = Enable
SAMPLE_RATE	Number of seconds per sample used for measurement validation data collection. This shouldn't exceed 10 seconds per sample, but currently there are no upper limits.
DEVIATION_LIMIT	Sets the limit for the deviation diagnostic. DD limits the upper range to 10.
DEVIATION_ENG_UNITS	Units tied to the deviation output value
DEVIATION_ALERT_SEVERITY	Advisory, Maintenance, Failure 0 = Disabled = Does not use the limits, but provides an output 1 = Advisory = No effect on sensor status, sets advisory PWA 2 = Maint = Sets sensor status to uncertain, sets advisory PWA 3 = Failure = Sets sensor status to Bad, sets advisory PWA
DEVIATION_PCNT_LIM_HYST	Deviation Hysteresis Limit = $(1 - \text{DEVIATION_PCNT_LIM_HYST}/100) * \text{DEVIATION_LIMIT}$
RATE_INCREASING_LIMIT	Increasing Rate of Change limit set point
RATE_DECREASING_LIMIT	Decreasing Rate of Change limit set point
RATE_ENG_UNITS	Units tied to the rate of change output value

Table 3-25: Validation Config sub-parameter structure (continued)

Parameter	Description
RATE_ALERT_SEVERITY	Advisory, Maintenance, Failure 0 = Disabled = Does not use the limits, but provides an output 1 = Advisory = No effect on sensor status, sets advisory PWA 2 = Maint = Sets sensor status to uncertain, sets advisory PWA 3 = Failure = Sets sensor status to Bad, sets advisory PWA
RATE_PCNT_LIM_HYST	Rate of Change Increasing Hysteresis Limit = $(1 - \text{RATE_PCNT_LIM_HYST}/100) * \text{RATE_INCREASING_LIMIT}$

Sensor calibration in the sensor transducer block

If the FOUNDATION Fieldbus configuration tool or host system does not support the use of DD methods for device configuration, the following steps illustrate how to calibrate the sensor from the sensor transducer block.

Note

Active calibrators should not be used in conduction with RTDs on any multiple input temperature transmitter such as the Rosemount 848T.

Procedure

1. Under SENSOR_CALIB, the SENSOR_NUMBER to the number of the sensor to calibrate.
2. Set CALIB_UNIT to calibration unit.
3. Set CALIB_METHOD to User Trim (see [Table 3-13](#) for valid values).
4. Set the input value of the sensor simulator to be within the range defined by CALIB_LO_LIMIT and CALIB_HI_LIMIT.
5. Set CALIB_POINT_LO (CALIB_POINT_HI) to the value set at the sensor simulator.
6. Read CALIB_STATUS and wait until it reads “Command Done”.
7. Repeat steps 3 to 5 if performing a two-point trim. Note that the difference in values between CALIB_POINT_LO and CALIB_POINT_HI must be greater than CALIB_MIN_SPAN.

4 Operation and maintenance

4.1 FOUNDATION Fieldbus information

FOUNDATION Fieldbus is an all-digital, serial, two-way, multi-drop communication protocol that interconnects devices such as transmitters and valve controllers. It is a local area network (LAN) for instruments that enable basic control and I/O to be moved to the field devices. The Rosemount™ 848T uses FOUNDATION Fieldbus technology developed and supported by Emerson Process Management and the other members of the independent Fieldbus Foundation.

Figure 4-1: Block diagram for the Rosemount 848T

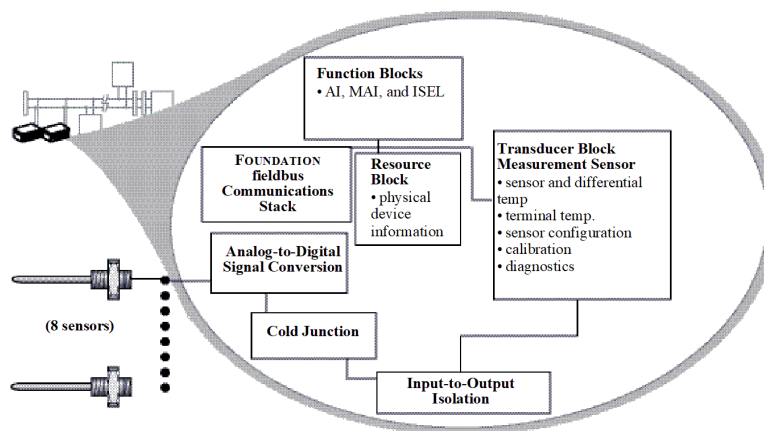

4.1.1 Commissioning (addressing)

To be able to setup, configure, and have it communicate with other devices on a segment, a device must be assigned a permanent address. Unless requested otherwise, it is assigned a temporary address when shipped from the factory.

If there are two or more devices on a segment with the same address, the first device to start up will use the assigned address (ex. Address 20). Each of the other devices will be given one of the four available temporary addresses. If a temporary address is not available, the device will be unavailable until a temporary address becomes available.

Use the host system documentation to commission a device and assign a permanent address.

4.2 Hardware maintenance

The Rosemount 848T has no moving parts and requires a minimal amount of scheduled maintenance. If a malfunction is suspected, check for an external cause before performing the diagnostics presented below.

4.2.1 Sensor check

To determine whether the sensor is causing the malfunction, connect a sensor calibrator or simulator locally at the transmitter. Consult an Emerson representative for additional temperature sensor and accessory assistance.

4.2.2 Communication/power check

If the transmitter does not communicate or provides an erratic output, check for adequate voltage to the transmitter. The transmitter requires between 9.0 and 32.0 VDC at the terminals to operate with complete functionality. Check for wire shorts, open circuits, and multiple grounds.

4.2.3 Resetting the configuration (RESTART)

There are two types of restarts available in the Resource Block. The following section outlines the usage for each of these. For further information, see RESTART in [Table 3-2](#).

Restart processor (cycling)

Performing a Restart Processor has the same effect as removing power from the device and reapplying power.

Restart with defaults

Performing a Restart with Defaults resets the static parameters for all of the blocks to their initial state. This is commonly used to change the configuration and/or control strategy of the device, including any custom configurations done at the Rosemount factory.

4.3 Troubleshooting

4.3.1 FOUNDATION Fieldbus

Symptom	Possible cause	Corrective action
Device does not show up in the live list	Network configuration parameters are incorrect	Set the network parameters of the LAS (host system) according to the FF Communications Profile:
		ST: 8
		MRD: 4
		DLPDU PhLO: 4
		MID: 7
		TSC: 4 (1 ms)
		T1: 96000 (3 seconds)
	T2: 9600000 (300 seconds)	
	T3: 480000 (15 seconds)	
	Network address is not in polled range	Set first Unpolled Node and Number of UnPolled Nodes so that the device address is within range.
	Power to the device is below the 9 VDC minimum	Increase the power to at least 9V.
	Noise on the power/communication is too high	Verify terminators and power conditioners are within specification Verify the shield is properly terminated and not grounded at both ends. It is best to ground the shield at the power conditioner.

Symptom	Possible cause	Corrective action
Device that is acting as a LAS does not send out CD	LAS Scheduler was not downloaded to the Backup LAS device	Ensure that all of the devices that are intended to be a Backup LAS are marked to receive the LAS schedule.
All devices go off live list and then return	Live list must be reconstructed by Backup LAS device	Current link setting and configured links settings are different. Set the current link setting equal to the configured settings.

4.3.2 Resource block

Symptom	Possible causes	Corrective action
Mode will not leave OOS	Target mode not set	Set target mode to something other than OOS.
	Memory Failure	BLOCK_ERR will show the lost NV Data or Lost Static Data bit set. Restart the device by setting RESTART to Processor. If the block error does not clear, call the factory.
Block Alarms Will not work	Features	FEATURES_SEL does not have Alerts enabled. Enable the report bit.
	Notification	LIM_NOTIFY is not high enough. Set equal to MAX_NOTIFY.

4.3.3 Transducer block troubleshooting

Symptom	Possible causes	Corrective action
Mode will not leave OOS	Target mode not set	Set target mode to something other than OOS.
	A/D board check sum error	The A/D board has a checksum error.
	Resource block	The actual mode of the Resource block is in OOS. See Resource Block Diagnostics for corrective action.
	Transducer Block	The actual mode of the Transducer Block is OOS.
The primary value is BAD	Measurement	Look at the SENSOR_STATUS parameter (See Table 3-16)

A Reference data

A.1 Functional specifications

A.1.1 Inputs

Inputs include:

- Eight independently configurable channels including combinations of 2- and 3-wire RTDs, thermocouples, mV, 2- and 3-wire and ohm inputs
- 4–20 mA inputs using optional connector(s)

A.1.2 Outputs

Outputs consist of Manchester-encoded digital signal that conforms to IEC 61158 and ISA 50.02.

A.1.3 Status

- 600 Vdc channel to channel isolation⁽¹⁾
- 10 Vdc channel to channel isolation for all operating conditions with maximum 500 ft (152 m) of sensor lead length 18 AWG (0.823 mm²).

A.1.4 Ambient temperature limits

-40 °F (-40 °C) to 185 °F (85 °C)

A.1.5 Isolation

Isolation between all sensor channels is rated to 10Vdc over all operating conditions. No damage will occur to the device with up to 600 Vdc between any sensor channel.

A.1.6 Power supply

Powered over FOUNDATION Fieldbus with standard fieldbus power supplies. The transmitter operates between 9.0 and 32.0 V dc, 22 mA maximum (transmitter power terminals are rated to 42.4 V dc).

A.1.7 Transient protection

The transient protector (option code T1) helps to prevent damage to the transmitter from transients induced on the loop wiring by lightning, welding, heavy electrical equipment, or switch gears. This option is installed at the factory for the Rosemount 848T and is not intended for field installation.

A.1.8 Update time

Approximately 1.5 seconds to read all eight inputs.

⁽¹⁾ Reference conditions are -40 °F (-40 °C) to 140 °F (60 °C) with 100 ft (30 m) of sensor lead length 18 AWG (0.823 mm²) wire.

A.1.9 Humidity limits

0–99% non-condensing relative humidity

A.1.10 Turn-on time

Performance within specifications is achieved in less than 30 seconds after power is applied to the transmitter.

A.1.11 Alarms

The AI and ISEL function blocks allow the user to configure the alarms to HI-HI, HI, LO, or LO-LO with a variety of priority levels and hysteresis settings.

A.1.12 Backup Link Active Scheduler (LAS)

The transmitter is classified as a device link master, which means it can function as a Link Active Scheduler (LAS) if the current link master device fails or is removed from the segment.

The host or other configuration tool is used to download the schedule for the application to the link master device. In the absence of a primary link master, the transmitter will claim the LAS and provide permanent control for the H1 segment.

FOUNDATION Fieldbus parameters

Schedule Entries	20
Links	30
Virtual Communications Relationships (VCR)	20

A.2 Physical specifications

A.2.1 Conformance to specifications ($\pm 3\sigma$ [Sigma])

Technology leadership, advanced manufacturing techniques, and statistical process control ensure specification conformance to at least $\pm 3\sigma$.

A.2.2 Mounting

The transmitter can be mounted directly onto a DIN rail or it can be ordered with an optional junction box. When using the optional junction box, the transmitter can be mounted onto a panel or a 2 in (51 mm) pipe stand (with option code B6).

A.2.3 Entries for optional junction box

No entry	Used for custom fittings.
Cable gland for aluminum junction box (JA4)	9 x ½-in. NPT nickel-plated brass glands for 7.5–11.9 mm unarmored cable

Cable gland for stainless steel junction box (JS2)	9 x M20 nickel-plated brass glands for 7.5–11.9 mm unarmored cable
Conduit	Five plugged 0.86-in. diameter holes suitable for installing ½-in. NPT fittings.

A.2.4 Materials of construction for optional junction box

Junction box type	Paint
Aluminum	Epoxy resin
Stainless steel	N/A

A.2.5 Weight

Assembly	Weight		
	oz	lb	kg
Rosemount 848T only	7.5	.47	.208
Rosemount 848T aluminum ⁽¹⁾	76	4.75	2.2
Stainless steel ⁽¹⁾	77.0	4.81	2.18

(1) Add 35.2 oz (2.2 lb, 0.998 kg) for nickel-plated brass glands.

A.2.6 Environmental ratings

Type 4X and IP66 with optional junction box.

A.3 Function blocks

A.3.1 Analog input (AI)

- Processes the measurement and makes it available on the fieldbus segment.
- Allows filtering, alarming, and engineering unit changes.

A.3.2 Input selector (ISEL)

- Used to select between inputs and generate an output using specific selection strategies such as minimum, maximum, midpoint, or average temperature.
- Since the temperature value always contains the measurement status, this block allows the selection to be restricted to the first “good” measurement.

A.3.3 Multiple analog input block (MAI)

- The MAI block allows the eight AI blocks to be multiplexed together so they serve as one function block on the H1 segment, resulting in greater network efficiency.

A.4 Performance specifications

A.4.1 Stability

- $\pm 0.1\%$ of reading or $0.1\text{ }^{\circ}\text{C}$ ($0.18\text{ }^{\circ}\text{F}$), whichever is greater, for 2 years for RTDs
- $\pm 0.1\%$ of reading or $0.1\text{ }^{\circ}\text{C}$ ($0.18\text{ }^{\circ}\text{F}$), whichever is greater, for 1 year for thermocouples

A.4.2 Self calibration

The transmitter's analog-to-digital circuitry automatically self-calibrates for each temperature update by comparing the dynamic measurement to extremely stable and accurate internal reference elements.

A.4.3 Vibration effect

Transmitters are tested to high pipeline vibration specification per IEC 60770-1 1999 with no effect on performance.

A.4.4 Electromagnetic compatibility compliance testing

- Meets the criteria under IEC 61326:2006
- Meets the criteria under European Union Directive 2004/108/EC

A.4.5 Accuracy

Table A-1: Input options/accuracy

Sensor option	Sensor reference	Input ranges		Accuracy over range(s)	
		$^{\circ}\text{C}$	$^{\circ}\text{F}$	$^{\circ}\text{C}$	$^{\circ}\text{F}$
2- and 3-Wire RTDs					
Pt 50 (a = 0.00391)	GOST 6651-94	-200 to 550	-328 to 1022	± 0.57	± 1.03
Pt 100 (a = 0.00391)	GOST 6651-94	-200 to 550	-328 to 1022	± 0.28	± 0.50
Pt 100 (a = 0.00385)	IEC 751; a = 0.00385, 1995	-200 to 850	-328 to 1562	± 0.30	± 0.54
Pt 100 (a = 0.003916)	JIS 1604, 1981	-200 to 645	-328 to 1193	± 0.30	± 0.54
Pt 200 (a = 0.00385)	IEC 751; a = 0.00385, 1995	-200 to 850	-328 to 1562	± 0.54	± 0.98
Pt 200 (a = 0.003916)	JIS 1604; a = 0.003916, 1981	-200 to 645	-328 to 1193	± 0.54	± 0.98
Pt 500	IEC 751; a = 0.00385, 1995	-200 to 850	-328 to 1562	± 0.38	± 0.68
Pt 1000	IEC 751; a = 0.00385, 1995	-200 to 300	-328 to 572	± 0.40	± 0.72
Ni 120	Edison Curve No. 7	-70 to 300	-94 to 572	± 0.30	± 0.54
Cu 10	Edison Copper Winding No. 15	-50 to 250	-58 to 482	± 3.20	± 5.76
Cu 100 (a=428)	GOST 6651-94	-185 to 200	-365 to 392	± 0.48	± 0.86
Cu 50 (a=428)	GOST 6651-94	-185 to 200	-365 to 392	± 0.96	± 1.73

Table A-1: Input options/accuracy (continued)

Sensor option	Sensor reference	Input ranges		Accuracy over range(s)	
		°C	°F	°C	°F
Cu 100 (a=426)	GOST 6651-94	-50 to 200	-122 to 392	± 0.48	± 0.86
Cu 50 (a=426)	GOST 6651-94	-50 to 200	-122 to 392	± 0.96	± 1.73
Thermocouples—Cold Junction Adds + 0.5 °C to Listed Accuracy					
NIST Type B (Accuracy varies according to input range)	NIST Monograph 175	100 to 300 301 to 1820	212 to 572 573 to 3308	± 6.00 ± 1.54	± 10.80 ± 2.78
NIST Type E	NIST Monograph 175	-200 to 1000	-328 to 1832	± 0.40	± 0.72
NIST Type J	NIST Monograph 175	-180 to 760	-292 to 1400	± 0.70	± 1.26
NIST Type K	NIST Monograph 175	-180 to 1372	-292 to 2501	± 1.00	± 1.80
NIST Type N	NIST Monograph 175	-200 to 1300	-328 to 2372	± 1.00	± 1.80
NIST Type R	NIST Monograph 175	0 to 1768	32 to 3214	± 1.50	± 2.70
NIST Type S	NIST Monograph 175	0 to 1768	32 to 3214	± 1.40	± 2.52
NIST Type T	NIST Monograph 175	-200 to 400	-328 to 752	± 0.70	± 1.26
DIN L	DIN 43710	-200 to 900	-328 to 1652	± 0.70	± 1.26
DIN U	DIN 43710	-200 to 600	-328 to 1112	± 0.70	± 1.26
w5Re26/W26Re	ASTME 988-96	0 to 2000	32 to 3632	± 1.60	± 2.88
GOST Type L	GOST R 8.585-2001	-200 to 800	-392 to 1472	± 0.71	± 1.28
Terminal Temperature		-50 to 85	-58 to 185	± 3.50	± 6.30
Ohm Input		0 to 2000 ohms		± 0.90 ohms	
Millivolt Input		-10 to 100 mV		± 0.05 mV	
1000 mV		-10 to 1000 mV		± 1.0 mA	
4–20 mA (Rosemount) ⁽¹⁾		4–20 mA		± 0.01 mA	
4–20 mA (NAMUR) ⁽¹⁾		4–20 mA		± 0.01 mA	
Multi-point Sensors ⁽²⁾					

(1) Requires the S002 option code.

(2) Multi-point (up to 8 points) thermocouples and RTDs are available for purchase with the Rosemount 848T. Input ranges and accuracy for these sensors will depend on the specific multi-point sensor chosen. For more information, contact your local Emerson representative.

A.4.6 Differential configuration notes

Differential capability exists between any two sensor types.

For all differential configurations, the input range is X to Y where:

- X = Sensor A minimum - Sensor B max.
- Y = Sensor A maximum - Sensor B min.

A.4.7 Accuracy for differential configurations

If sensor types are similar (for example, both RTDs or both thermocouples), the accuracy = 1.5 times worst case accuracy of either sensor type. If sensor types are dissimilar (for example, one RTD and one thermocouple), the accuracy = Sensor 1 Accuracy + Sensor 2 Accuracy.

A.4.8 Analog sensors 4–20mA

Two types of 4–20 mA sensors are compatible with the Rosemount 848T. These types must be ordered with the S002 option code complete with an analog connector kit. The alarm levels, accuracy for each type are listed in [Table A-2](#).

Table A-2: Analog sensors

Sensor option	Alarm levels	Accuracy
4–20mA (Rosemount Standard)	3.9 to 20.8 mA	± 0.01mA
4–20mA (NAMUR)	3.8 to 20.5 mA	± 0.01mA

A.4.9 Ambient temperature effect

Transmitter may be installed in locations where the ambient temperature is between -40 °F (-40 °C) and 185 °F (85 °C).

A.4.10 Ambient temperature effects

NIST type	Accuracy per 1.0 °C (1.8 °F) Change in Ambient Temperature ⁽¹⁾ °C	Temperature range (°C)
RTD		
Pt 50 ($\alpha = 0.00391$)	0.004 °C (0.0072 °F)	N/A
Pt 100 ($\alpha = 0.00391$)	0.002 °C (0.0036 °F)	N/A
Pt 100 ($\alpha = 0.00385$)	0.003 °C (0.0054 °F)	N/A
Pt 100 ($\alpha = 0.003916$)	0.003 °C (0.0054 °F)	N/A
Pt 200 ($\alpha = 0.003916$)	0.004 °C (0.0072 °F)	N/A
Pt 200 ($\alpha = 0.00385$)	0.004 °C (0.0072 °F)	N/A
Pt 500	0.003 °C (0.0054 °F)	N/A
Pt 1000	0.003 °C (0.0054 °F)	N/A
Cu 10	0.03 °C (0.054 °F)	N/A
Cu 100 (a=428)	0.002 °C (0.0036 °F)	N/A
Cu 50 (a=428)	0.004 °C (.0072 °F)	N/A
Cu 100 (a=426)	0.002 °C (0.0036 °F)	N/A
Cu 50 (a=426)	0.004 °C (.0072 °F)	N/A
Ni 120	0.003 °C (0.0054 °F)	N/A
Thermocouple (R = the value of the reading)		

NIST type	Accuracy per 1.0 °C (1.8 °F) Change in Ambient Temperature ⁽¹⁾ °C	Temperature range (°C)
Type B	<ul style="list-style-type: none"> 0.014 °C 0.032 °C - (0.0025% of (R - 300)) 0.054 °C - (0.011% of (R - 100)) 	<ul style="list-style-type: none"> R ≥ 1000 300 ≤ R < 1000 100 ≤ R < 300
Type E	0.005 °C + (0.00043% of R)	All
Type J, DIN Type L	<ul style="list-style-type: none"> 0.0054 °C + (0.00029% of R) 0.0054 °C + (0.0025% of R) 	<ul style="list-style-type: none"> R ≥ 0 R < 0
Type K	<ul style="list-style-type: none"> 0.0061 °C + (0.00054% of R) 0.0061 °C + (0.0025% of R) 	<ul style="list-style-type: none"> R ≥ 0 R < 0
Type N	0.0068 °C + (0.00036% of R)	All
Type R, Type S	<ul style="list-style-type: none"> 0.016 °C 0.023 °C - (0.0036% of R) 	<ul style="list-style-type: none"> R ≥ 200 R < 200
Type T, DIN Type U	<ul style="list-style-type: none"> 0.0064 °C 0.0064 °C + (0.0043% of R) 	<ul style="list-style-type: none"> R ≥ 0 R < 0
GOST Type L	<ul style="list-style-type: none"> 0.007 °C 0.007 °C + (0.003% of IRI) 	<ul style="list-style-type: none"> R ≥ 0 R < 0
Millivolt	0.0005 mV	N/A
2- and 3-wire ohm	0.0084 ohms	N/A
4–20 mA (Rosemount)	0.0001 mA	N/A
4-20 mA (NAMUR)	0.0001 mA	N/A

(1) Change in ambient is in reference to the calibration temperature of the transmitter (20 °C (68 °F) typical from the factory).

A.4.11 Ambient temperature notes

Examples

When using a Pt 100 ($\alpha = 0.00385$) sensor input at 30 °C ambient temperature:

- Digital Temperature Effects: $0.003 \text{ °C} \times (30 - 20) = 0.03 \text{ °C}$
- Worst Case Error: Digital + Digital Temperature Effects = $0.3 \text{ °C} + 0.03 \text{ °C} = 0.33 \text{ °C}$
- Total Probable Error $\sqrt{0.30^2 + 0.03^2} = 0.30 \text{ °C}$

A.5 Dimensional drawings for Rosemount 848T FOUNDATION Fieldbus

A.5.1 Junction boxes

External dimensions for junction boxes with no entries are the same as those outlined for the other junction box materials in this section.

Figure A-1: Rosemount 848T

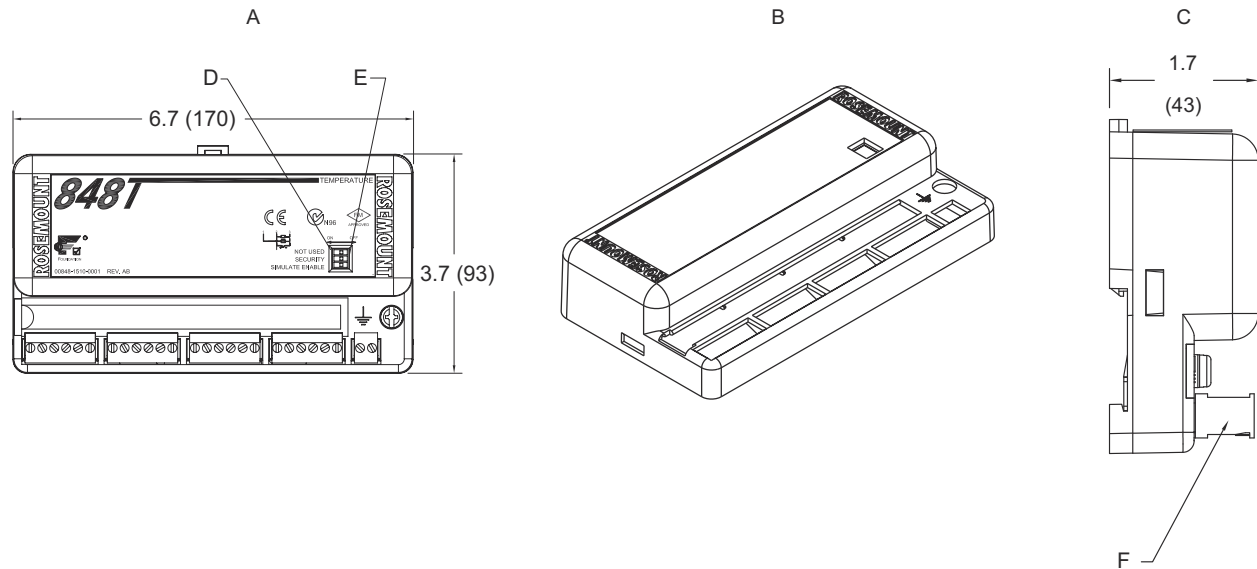

Dimensions are in inches (millimeters).

- A. Top view
- B. 3-D view
- C. Side view
- D. Security switch
- E. Simulation switch
- F. Removable wiring connection

A.5.2 Aluminum junction box

Figure A-2: Aluminum junction box with cable glands (option code JA4)

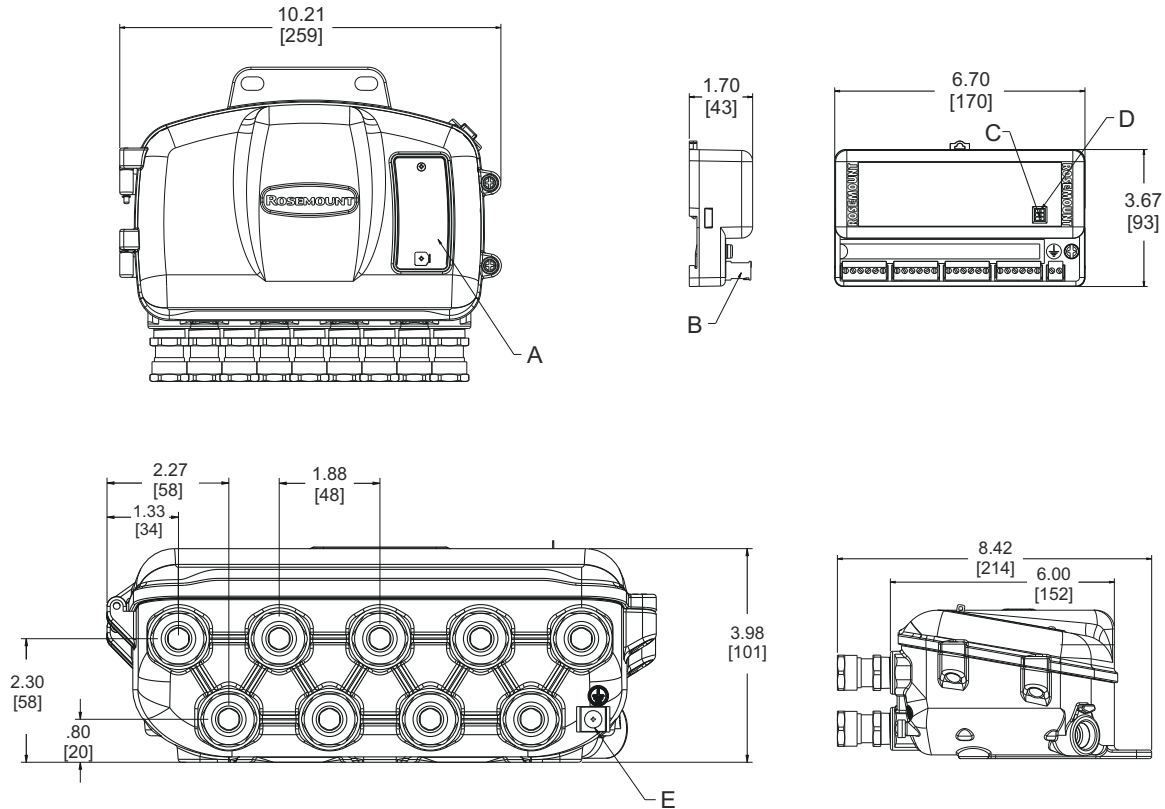

- A. Nameplate
- B. Removable wiring connector
- C. Security switch
- D. Simulation switch
- E. External ground screw (optional)

Dimensions are in inches (millimeters).

Figure A-3: Aluminum junction box with plugged holes (option code JA5)

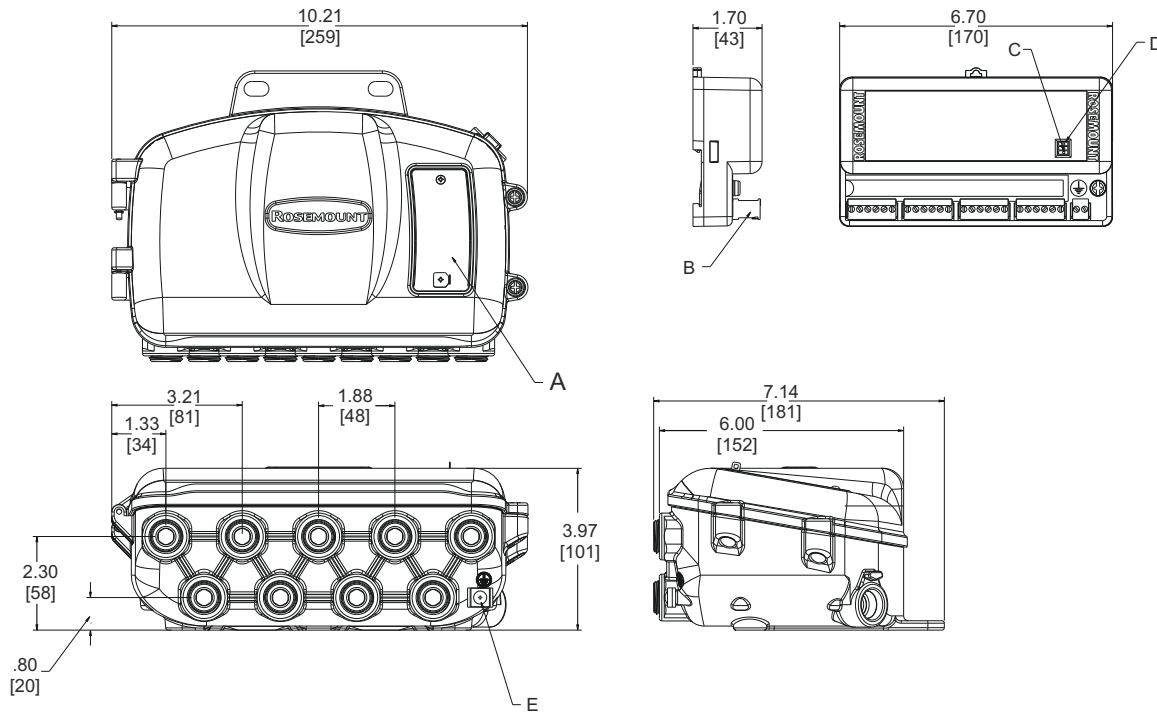

- A. Nameplate
- B. Removable wiring connection
- C. Security switch
- D. Simulation switch
- E. External ground screw (optional)

Dimensions are in inches (millimeters).

A.5.3 Stainless steel junction box

Figure A-4: Stainless steel junction box with cable glands (option code JS2)

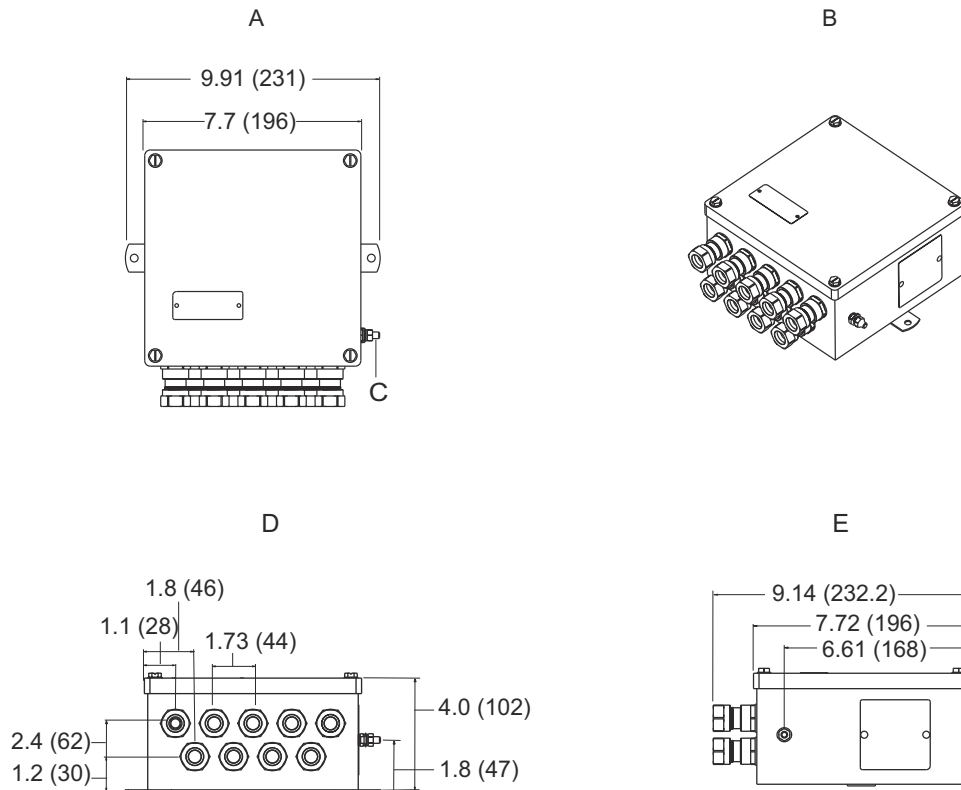

- A. Top view
- B. 3-D view
- C. Ground screw
- D. Front view
- E. Side view

Dimensions are in inches (millimeters).

Figure A-5: Stainless steel junction box with a conduit entry (option code JS3)

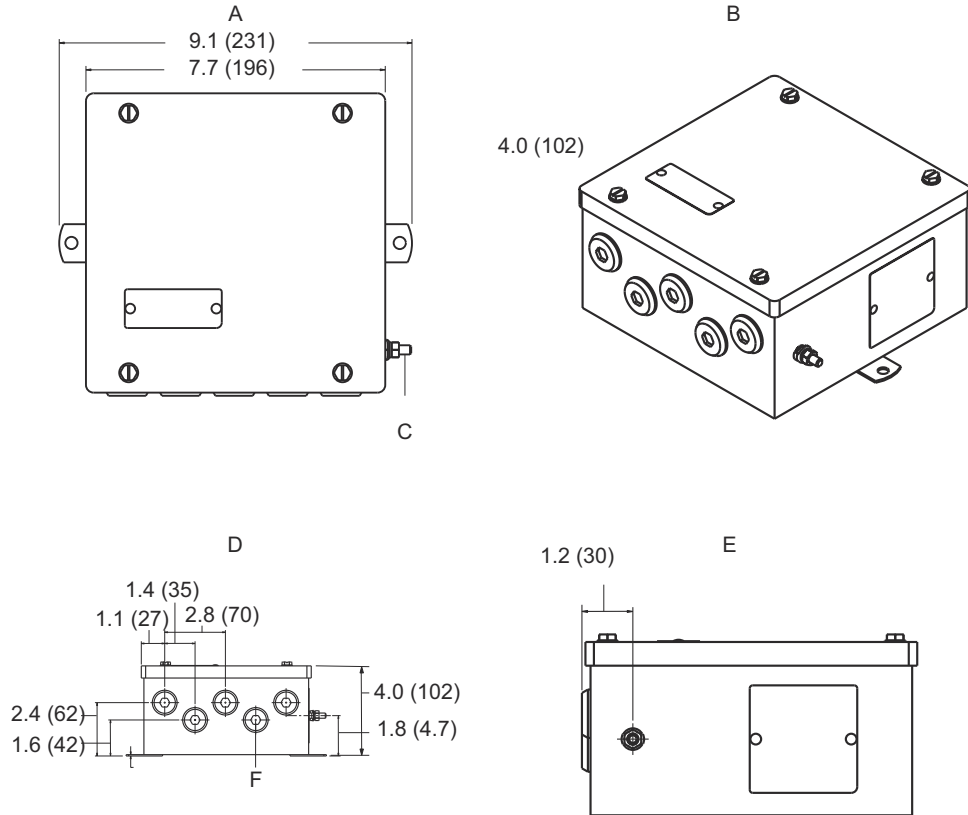

- A. Top view
- B. 3-D view
- C. Ground screw
- D. Front view
- E. Side view
- F. Five plugged 0.86 in (21.8 mm) diameter holes suitable for installing 1/2-in. NPT fittings

Dimensions are in inches (millimeters).

A.5.4 Mounting options

Figure A-6: Mount an aluminum junction box

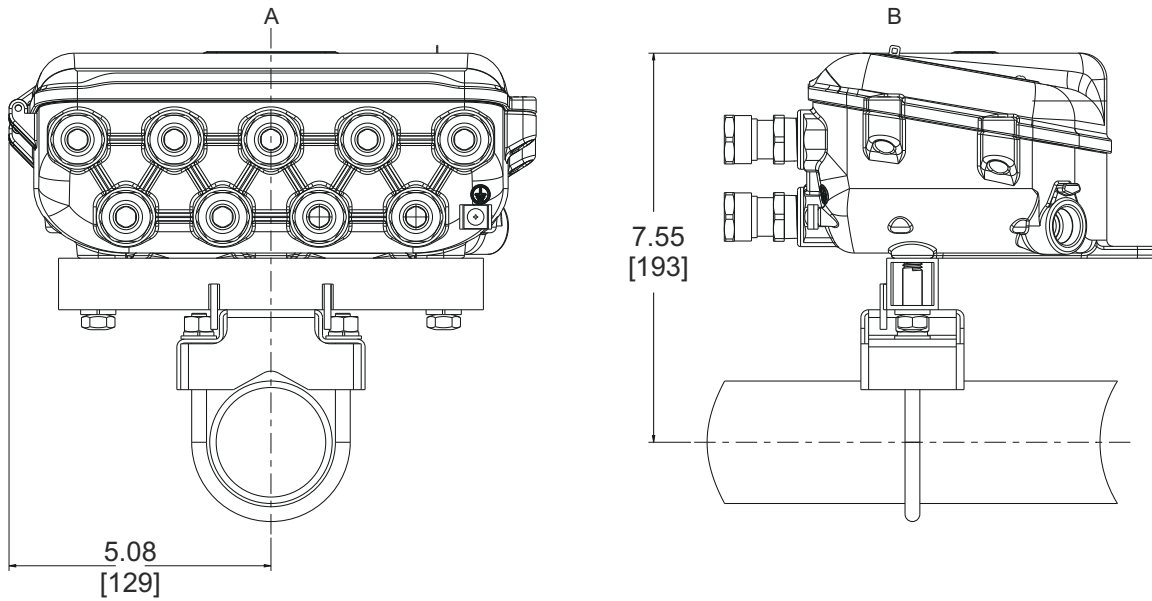

A. Front view

B. Side view

Dimensions are in inches (millimeters)

Figure A-7: Mount a stainless steel junction box

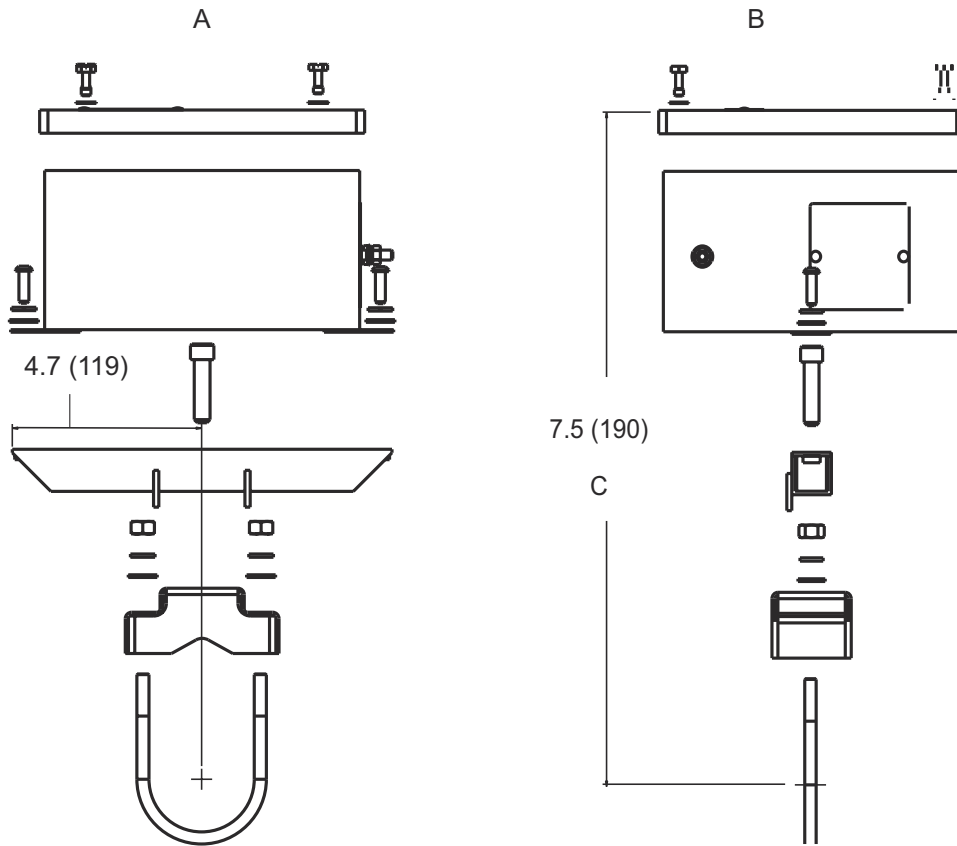

- A. Front view
- B. Side view
- C. Fully assembled

Dimensions are in inches (millimeters)

Figure A-8: Mount aluminum on a vertical pipe

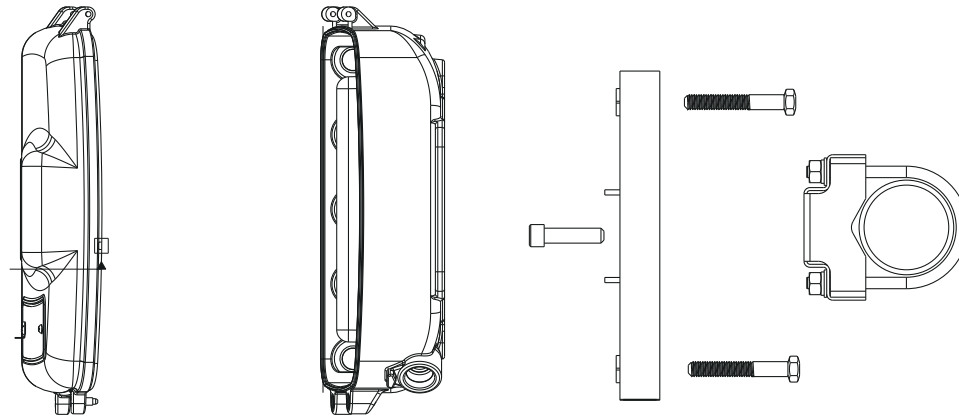
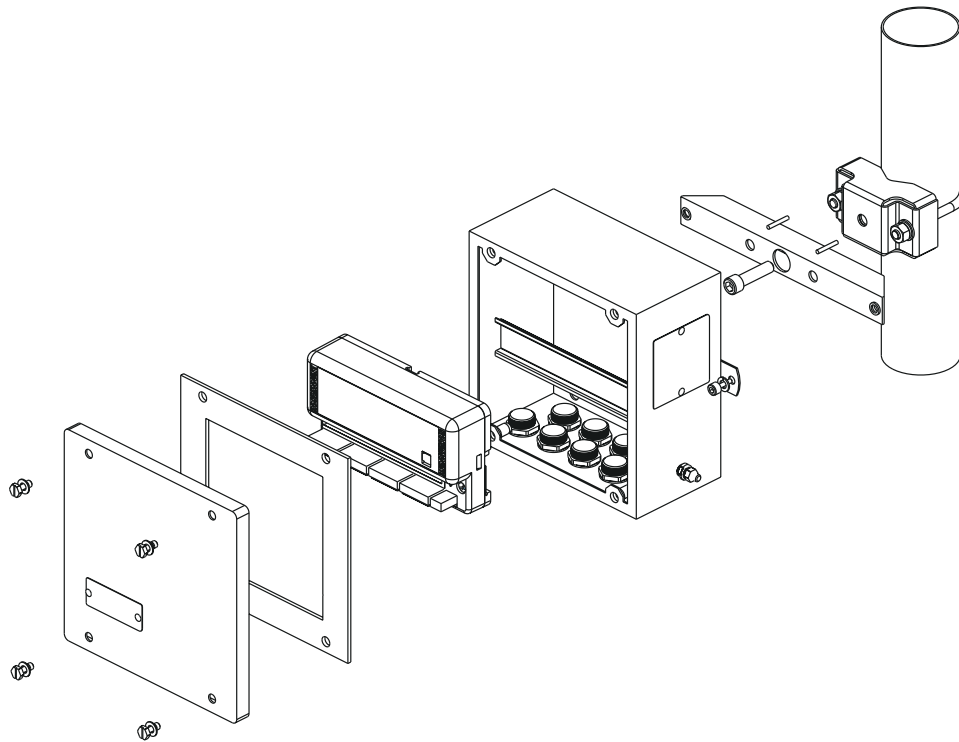

Figure A-9: Mount stainless steel on vertical pipe



A.6 Ordering information

Table A-3: Rosemount 848T FOUNDATION fieldbus Ordering Information

The Standard offering represents the most common options. The starred options (★) should be selected for best delivery. The Expanded offering is subject to additional delivery lead time.

Model	Product description		
848T	High Density Temperature Measurement Family		
Transmitter output			
F	FOUNDATION fieldbus digital signal (includes AI, MAI, and ISEL function blocks, and Backup Link Active Scheduler)		★
Product certifications⁽¹⁾		Rosemount junction box required?	
I1	ATEX Intrinsic Safety	No	★
I3	NEPSI Intrinsic Safety	No	★
I4	TIIS Intrinsically Safety (FISCO) Type “ia”	No	★
H4	TIIS Intrinsic Safety (FISCO) Type “ib”	No	★
I5 ⁽²⁾	FM Intrinsically Safe	No	★
I6 ⁽²⁾	CSA Intrinsically Safe	No	★
I7	IECEx Intrinsic Safety	No	★
IA	ATEX FISCO Intrinsic Safety	No	★
IE	FM FISCO Intrinsically Safe	No	★
IF ⁽²⁾	CSA FISCO Intrinsically Safe, Division 2	No	★
IG	IECEx FISCO (Intrinsic Safety)	No	★
N1	ATEX Type n (enclosure required)	Yes	★
N5	FM Class I, Division 2, and Dust Ignition-proof (enclosure required)	Yes	★
N6	CSA Class I, Division 2	No	★
N7	IECEx Type n (enclosure required)	Yes	★
NC	ATEX Type n Component (Ex nA nL)	No ⁽³⁾	★
ND	ATEX Dust (enclosure required)	Yes	★
NJ	IECEx Type n Component (Ex nA nL)	No ⁽³⁾	★
NK	FM Class 1, Division 2	No	★
NA	No Approval	No	★
Options (include with selected model number)			
Input types			
S001	RTD, Thermocouple, mV, ohm Inputs		★
S002 ⁽⁴⁾	RTDs, Thermocouple, mV, ohm and 4–20 mA Inputs		★
PlantWeb advanced diagnostics			
D04	Measurement Validation Diagnostic		★
Transient protection			
T1	Integral Transient Protector		★

Table A-3: Rosemount 848T FOUNDATION fieldbus Ordering Information (continued)

Model	Product description	
Mounting bracket		
B6	Mounting Bracket for 2-in. pipe mounting – SST bracket and bolts	★
Enclosure options		
JA1	Aluminum Junction Box; No Entries	★
JA2	Aluminum Cable Glands (9 x M20 nickel-plated brass glands for 7.5–11.9 mm unarmored cable)	★
JA3	Aluminum Conduit Entries (5 Plugged Holes, suitable for installing 1/2-in. NPT fittings)	★
JA4	Aluminum with cable glands (9 x 1/2-in. NPT for 7.5 to 11.9 mm)	★
JA5	Aluminum with conduit entries (nine plugged holes, suitable for installing 1/2-in. NPT fittings)	★
JS1	Stainless Steel Junction Box; No Entries	★
JS2	Stainless Steel Box, Cable Glands (9 x M20 nickel-plated brass glands for 7.5–11.9 mm unarmored cable)	★
JS3	Stainless Steel Box, Conduit Entries (5 Plugged Holes, suitable for installing 1/2-in. NPT fittings)	★
Software configuration		
C1	Custom Configuration of Date, Descriptor, Message and Wireless Parameters (Requires CDS with Order)	★
Line filter		
F5	50 Hz Line Voltage Filter	★
Calibration certificate		
Q4	Calibration Certificate (3-Point Calibration)	★
Shipboard certification		
SBS	American Bureau of Shipping (ABS) Type Approval	★
SLL	Lloyd's Register (LR) Type Approval	★
Special temperature test		
LT	Test to -60 °F (-51.1 °C)	
Conduit electrical connector		
GE ⁽⁵⁾	M12, 4-pin, Male Connector (eurofast [®])	★
GM ⁽⁵⁾	A size Mini, 4-pin, Male Connector (minifast [®])	★
Typical model number: 848T F I5 S001 T1 B6 JA2		

- (1) Consult factory for availability.
- (2) Available only with S001 option.
- (3) The Rosemount 848T ordered with component approval is not approved as a stand-alone unit. Additional system certification is required.
- (4) S002 is only available with Product Certification N5, N6, N1, NC, NK, and NA.
- (5) Available with no approval or Intrinsically Safe approvals only. For FM Intrinsically Safe (option code I5), install in accordance with Rosemount drawing 00848-4402.

B Product certifications

Rev 3.13

B.1 European Directive Information

A copy of the EC Declaration of Conformity can be found at the end of the Quick Start Guide. The most recent revision of the EC Declaration of Conformity can be found at [Emerson.com/Rosemount](https://emerson.com/rosemount).

B.2 Ordinary Location Certification

As standard, the transmitter has been examined and tested to determine that the design meets the basic electrical, mechanical, and fire protection requirements by FM Approvals, a nationally recognized test laboratory (NRTL) as accredited by the Federal Occupational Safety and Health Administration (OSHA).

B.3 North America

The US National Electrical Code® (NEC) and the Canadian Electrical Code (CEC) permit the use of Division marked equipment in Zones and Zone marked equipment in Divisions. The markings must be suitable for the area classification, gas, and temperature class. This information is clearly defined in the respective codes.

B.4 USA

B.4.1 I5 USA Intrinsically Safe and Nonincendive

Certificate 3011568

Standards FM Class 3600:1998, FM Class 3610:2010, FM Class 3611:2004, FM Class 3810:2005, ANSI/ISA 60079-0:2009, ANSI/ISA 60079-11:2009, NEMA 250:1991, IEC 60529:2011

Markings IS CL I, DIV 1, GP A, B, C, D; T4($-50\text{ °C} \leq T_a \leq +60\text{ °C}$); NI CL I, DIV 2, GP A, B, C, D; T4A($-50\text{ °C} \leq T_a \leq +85\text{ °C}$); T5($-50\text{ °C} \leq T_a \leq +70\text{ °C}$) when installed per Rosemount drawing 00848-4404.

Note

Transmitters marked with Nonincendive CL I, DV 2 can be installed in Division 2 locations using general Division 2 wiring methods or Nonincendive Field Wiring (NIFW). See Drawing 00848-4404.

B.4.2 IE USA FISCO

Certificate 3011568

Standards FM Class 3600:1998, FM Class 3610:2010, FM Class 3611:2004, FM Class 3810:2005, ANSI/ISA 60079-0:2009, ANSI/ISA 60079-11:2009, NEMA 250:1991, IEC 60529:2011

Markings IS CL I, DIV 1, GP A, B, C, D; T4($-50\text{ °C} \leq T_a \leq +60\text{ °C}$); NI CL I, DIV 2, GP A, B, C, D; T4A($-50\text{ °C} \leq T_a \leq +85\text{ °C}$); T5($-50\text{ °C} \leq T_a \leq +70\text{ °C}$) when installed per Rosemount drawing 00848-4404.

B.4.3 N5 USA Nonincendive and Dust-Ignitionproof

Certificate 3011568

Standards FM Class 3600:1998, FM Class 3611:2004, FM Class 3810:2005, ANSI/ISA 60079-0:2009, NEMA 250:1991, IEC 60529:2011

Markings NI CL I, DIV 2, GP A, B, C, D; DIP CL II/III, DIV 1, GP E, F, G; T4A($-50\text{ °C} \leq T_a \leq +85\text{ °C}$); T5($-50\text{ °C} \leq T_a \leq +70\text{ °C}$) when installed per Rosemount drawing 00848-4404; Type 4X

B.4.4 NK USA Nonincendive

Certificate 3011568

Standards FM Class 3600:1998, FM Class 3611:2004, FM Class 3810:2005, ANSI/ISA 60079-0:2009, NEMA 250:1991, IEC 60529:2001

Markings NI CL I, DIV 2, GP A, B, C, D; T4A($-50\text{ °C} \leq T_a \leq +85\text{ °C}$); T5($-50\text{ °C} \leq T_a \leq +70\text{ °C}$) when installed per Rosemount drawing 00848-4404

Note

Only the N5 and NK are valid with the S002 option.

Table B-1: Entity parameters

Fieldbus (input)	FISCO (input)	Nonincendive (input)	Sensor field terminal (output)
$V_{MAX} = 30\text{ V}$	$V_{MAX} = 17.5$	$V_{MAX} = 42.4$	$V_{OC} = 12.5\text{ V}$
$I_{MAX} = 300\text{ mA}$	$I_{MAX} = 380\text{ mA}$	$C_i = 2.1\text{ nF}$	$I_{SC} = 4.8\text{ mA}$
$P_i = 1.3\text{ W}$	$P_i = 5.32\text{ W}$	$L_i = 0$	$P_O = 15\text{ mW}$
$C_i = 2.1\text{ nF}$	$C_i = 2.1\text{ nF}$	-	$C_A = 1.2\text{ }\mu\text{F}$
$L_i = 0$	$L_i = 0$	-	$L_A = 1\text{ H}$

B.5 Canada

B.5.1 E6 Canada Explosionproof, Dust-Ignitionproof, Division 2 (JX3 Enclosure Required)

Certificate 1261865

Standards CAN/CSA C22.2 No. 0-M91 (R2001), CSA Std. C22.2 No. 25.1966, CSA Std. C22.2 No. 30-M1986, CAN/CSA C22.2 No. 94-M91, CSA Std. C22.2 No. 142-M1987, CSA Std. C22.2 No. 213-M1987, CSA Std. C22.2 No. 60529:05

Markings Explosionproof for Class I, Division 1, Groups B, C, and D; T4($-40\text{ °C} \leq T_a \leq +40\text{ °C}$) when installed per Rosemount drawing 00848-1041; Dust-Ignitionproof for Class II, Division 1, Groups E, F, and G; Class III; Class I, Division 2, Groups A, B, C, and D; T3C($-50\text{ °C} \leq T_a \leq +60\text{ °C}$) when installed per Rosemount drawing 00848-4405; Conduit Seal Required

B.5.2 I6 Canada Intrinsically Safe and Division 2

Certificate 1261865

Standards CAN/CSA C22.2 No. 0-M91 (R2001), CAN/CSA C22.2 No. 94-M91, CSA Std. C22.2 No. 142-M1987, CSA Std. C22.2 No. 157-92, CSA Std. C22.2 No. 213-M1987, CSA Std. C22.2 No. 60529:05

Markings Intrinsically Safe for Class I, Division 1, Groups A, B, C, and D; T3C($-50\text{ }^{\circ}\text{C} \leq T_a \leq +60\text{ }^{\circ}\text{C}$) when installed per Rosemount drawing 00848-4405; Class I, Division 2, Groups A, B, C, D; T3C($-50\text{ }^{\circ}\text{C} \leq T_a \leq +60\text{ }^{\circ}\text{C}$) when installed per Rosemount drawing 00848-4405

B.5.3 IF Canada FISCO

Certificate 1261865

Standards CAN/CSA C22.2 No. 0-M91 (R2001), CAN/CSA C22.2 No. 94-M91, CSA Std. C22.2 No. 142-M1987, CSA Std. C22.2 No. 157-92, CSA Std. C22.2 No. 213-M1987, CSA Std. C22.2 No. 60529:05

Markings Intrinsically Safe for Class I, Division 1, Groups A, B, C, and D; T3C($-50\text{ }^{\circ}\text{C} \leq T_a \leq +60\text{ }^{\circ}\text{C}$) when installed per Rosemount drawing 00848-4405; Class I, Division 2, Groups A, B, C, D; T3C($-50\text{ }^{\circ}\text{C} \leq T_a \leq +60\text{ }^{\circ}\text{C}$) when installed per Rosemount drawing 00848-4405

B.5.4 N6 Canada Division 2 and Dust-Ignitionproof (enclosure required)

Certificate 1261865

Standards CAN/CSA C22.2 No. 0-M91 (R2001), CSA Std. C22.2 No. 30-M1986, CAN/CSA C22.2 No. 94-M91, CSA Std. C22.2 No. 142-M1987, CSA Std. C22.2 No. 213-M1987, CSA Std. C22.2 No. 60529:05

Markings Class I, Division 2, Groups A, B, C, and D; T3C($-50\text{ }^{\circ}\text{C} \leq T_a \leq +60\text{ }^{\circ}\text{C}$) when installed per Rosemount drawing 00848-4405; Dust-Ignitionproof for Class II, Division 1, Groups E, F, and G; Class III; Conduit Seal Required

B.6 Europe

B.6.1 I1 ATEX Intrinsic Safety

Certificate Baseefa09ATEX0093X

Standards EN IEC 60079-0:2018, EN 60079-11:2012

Markings  II 1 G Ex ia IIC T4 Ga ($-50\text{ }^{\circ}\text{C} \leq T_a \leq +60\text{ }^{\circ}\text{C}$) when installed per drawing 00848-4406

Special Conditions for Safe Use (X):

1. The equipment must be installed in an enclosure that provides a degree of protection of at least IP20. Non-metallic enclosures must be suitable to prevent electrostatic hazards and light alloy or zirconium enclosures must be protected from impact and friction when installed.
2. The equipment is not capable of withstanding the 500 V insulation test required by EN 60079-11:2011, clause 6.3.13. This must be taken into account when installing the equipment.

Fieldbus (input)	Sensor field terminal (output)
$U_i = 30 \text{ V}$	$U_o = 12.5 \text{ V}$
$I_i = 300 \text{ mA}$	$I_o = 4.8 \text{ mA}$
$P_i = 1.3 \text{ W}$	$P_o = 15 \text{ mW}$
$C_i = 2.1 \text{ nF}$	$C_o = 1.2 \text{ }\mu\text{F}$
$L_i = 0$	$L_o = 1 \text{ H}$

B.6.2 IA ATEX FISCO Intrinsic Safety

Certificate Baseefa09ATEX0093X

Standards EN IEC 60079-0:2018, EN 60079-11:2012

Markings  II 1 G Ex ia IIC T4 Ga ($-50 \text{ }^\circ\text{C} \leq T_a \leq +60 \text{ }^\circ\text{C}$) when installed per drawing 00848-4406

Special Conditions for Safe Use (X):

1. The equipment must be installed in an enclosure that provides a degree of protection of at least IP20. Non-metallic enclosures must be suitable to prevent electrostatic hazards and light alloy or zirconium enclosures must be protected from impact and friction when installed.
2. The equipment is not capable of withstanding the 500 V insulation test required by EN 60079-11:2011, clause 6.3.13. This must be taken into account when installing the equipment.

FISCO (input)	Sensor field terminal (output)
$U_i = 17.5 \text{ V}$	$U_o = 12.5 \text{ V}$
$I_i = 380 \text{ mA}$	$I_o = 4.8 \text{ mA}$
$P_i = 5.32 \text{ W}$	$P_o = 15 \text{ mW}$
$C_i = 2.1 \text{ nF}$	$C_o = 1.2 \text{ }\mu\text{F}$
$L_i = 0$	$L_o = 1 \text{ H}$

B.6.3 N1 ATEX Zone 2 (with enclosure)

Certificate Baseefa09ATEX0095X

Standards EN IEC 60079-0:2018, EN 60079-7:2015 + A1:2018, EN 60079-15:2010

Markings  II 3G Ex nA IIC T5 Gc ($-40 \text{ }^\circ\text{C} \leq T_a \leq +65 \text{ }^\circ\text{C}$), Ex ec IIC T5 Gc ($-40 \text{ }^\circ\text{C} \leq T_a \leq +65 \text{ }^\circ\text{C}$)

Special Conditions for Safe Use (X):

1. The equipment must only be installed in an area of pollution degree 2 or better, as defined in IEC 60664-1.
2. Provision must be made, external to the equipment, to ensure the rated voltage of the equipment supply is not exceeded by transient disturbances of more than 40 percent.
3. The electrical circuit is connected directly to earth; this must be taken into account when installing the apparatus.

B.6.4 NC ATEX Zone 2 Component (without enclosure)

Certificate Baseefa09ATEX0094U

Standards EN IEC 60079-0:2018, EN 60079-7:2015 + A1:2018, EN 60079-15:2010

Markings  II 3G Ex nA IIC T4 Gc (-50 °C ≤ T_a ≤ +85 °C) or Ex nA IIC T5 Gc (-50 °C ≤ T_a ≤ +70 °C), Ex ec IIC T4 Gc (-50 °C ≤ T_a ≤ +85 °C) or Ex ec IIC T5 Gc (-50 °C ≤ T_a ≤ +70 °C)

Schedule of Limitations (U):

1. The equipment must only be installed in an area of pollution degree 2 or better, as defined in IEC 60664-1, and in an enclosure that provides a degree of protection of at least IP54 in accordance with EN 60079-0.
2. Provision must be made, external to the component, to ensure the rated voltage of the component supply is not exceeded by transient disturbances of more than 40 percent.
3. The electrical circuit is connected directly to earth; this must be taken into account when installing the apparatus.

B.7 International

B.7.1 I7 IECEx Intrinsic Safety

Certificate IECEx BAS 09.0030X

Standards IEC 60079-0:2017, IEC 60079-11:2011

Markings Ex ia IIC T4 Ga (-50 °C ≤ T_a ≤ +60 °C)

Special Conditions for Safe Use (X):

1. The apparatus must be installed in an enclosure that provides a degree of protection of at least IP20. Non-metallic enclosures must be suitable to prevent electrostatic hazards and light alloy or zirconium enclosures must be protected from impact and friction when installed.
2. The apparatus is not capable of withstanding the 500 V insulation test required by IEC 60079-11:2011, clause 6.3.13. This must be taken into account when installing the apparatus.

B.7.2 IG IECEx FISCO Intrinsic Safety

Certificate IECEx BAS 09.0030X

Standards IEC 60079-0:2017, IEC 60079-11:2011

Markings Ex ia IIC T4 Ga (-50 °C ≤ T_a ≤ +60 °C)

Special Conditions for Safe Use (X):

1. The equipment must be installed in an enclosure that provides a degree of protection of at least IP20. Non-metallic enclosures must be suitable to prevent electrostatic hazards and light alloy or zirconium enclosures must be protected from impact and friction when installed.
2. The equipment is not capable of withstanding the 500 V insulation test required by EN 60079-11:2012, clause 6.3.13. This must be taken into account when installing the equipment.

FISCO (input)	Sensor field terminal (output)
U _i = 17.5 V	U _O = 12.5 V
I _i = 380 mA	I _O = 4.8 mA
P _i = 5.32 W	P _O = 15 mW
C _i = 2.1 nF	C _O = 1.2 μF
L _i = 0	L _O = 1 H

B.7.3 N7 IECEx Type n (with enclosure)

Certificate: IECEx BAS 09.0032X

Standards: IEC 60079-0:2017, IEC 60079-7:2017, IEC 60079-15:2010

Markings: Ex nA IIC T5 Gc (-40 °C ≤ T_a ≤ +65 °C), Ex ec IIC T5 Gc (-40 °C ≤ T_a ≤ +65 °C)

Special Conditions for Safe Use (X):

1. The equipment must only be installed and used in an area of pollution degree 2 or better, as defined in IEC 60664-1.
2. Provision must be made, external to the apparatus, to ensure the rated voltage of the apparatus supply is not exceeded by transient disturbances of more than 40 percent.
3. The electrical circuit is connected directly to earth. This must be taken into account when installing the apparatus.

B.7.4 NJ IECEx Type n (without enclosure)

Certificate: IECEx BAS 09.0031U

Standards: IEC 60079-0:2017, IEC 60079-7:2017, IEC 60079-15:2010

Markings: Ex nA IIC T4 Gc(-50 °C ≤ T_a ≤ +85 °C), Ex nA IIC T5 Gc (-50 °C ≤ T_a ≤ +70 °C), Ex ec IIC T4 Gc(-50 °C ≤ T_a ≤ +85 °C), Ex ec IIC T5 Gc (-50 °C ≤ T_a ≤ +70 °C)

Schedule of Limitations (U):

1. The component must be only installed and used in an area of pollution degree 2 or better, as defined in IEC 60664-1, and in an enclosure that provides a degree of protection of at least IP54 in accordance with IEC 60079-0
2. Provision must be made, external to the component, to ensure the rated voltage of the component supply is not exceeded by transient disturbances of more than 40 percent.
3. The electrical circuit is connected directly to earth; this must be taken into account when installing the apparatus.

B.8 Brazil

B.8.1 I2 Brazil Intrinsic Safety

Certificate UL-BR 16.0086X

Standards ABNT NBR IEC 60079-0:2008 + Errata 1:2011 ABNT NBR IEC 60079-11:2009

Markings Ex ia IIC T4(-50 °C ≤ T_a ≤ +60 °C)

Special Conditions for Safe Use (X):

1. The apparatus must be installed in an enclosure that provides a degree of protection of at least IP20. Non-metallic enclosures must be suitable to prevent electrostatic hazards (see manufacturer's instructions manual) and light alloy or zirconium enclosures must be protected from impact and friction when installed.
2. The apparatus is not capable of withstanding the 500 V isolation test required by ABNT NBR IEC 60079-11. This must be taken into account when installing the apparatus --- see manufacturer's instructions manual.

Fieldbus (input)	Sensor field terminal (output)
U _i = 30 V	U _o = 12.5 V
I _i = 300 mA	I _o = 4.8 mA
P _i = 1.3 W	P _o = 15 mW
C _i = 2.1 nF	C _o = 1.2 μF
L _i = 0	L _o = 1 H

B.8.2 IB Brazil Intrinsic Safety

Certificate UL-BR 16.0086X

Standards ABNT NBR IEC 60079-0:2008 + Errata 1:2011, ABNT NBR IEC 60079-11:2009

Markings Ex ia IIC T4(-50 °C ≤ T_a ≤ +60 °C)

Special Conditions for Safe Use (X):

1. The apparatus must be installed in an enclosure that provides a degree of protection of at least IP20. Non-metallic enclosures must be suitable to prevent electrostatic hazards (see manufacturer's instructions manual) and light alloy or zirconium enclosures must be protected from impact and friction when installed.
2. The apparatus is not capable of withstanding the 500 V isolation test required by ABNT NBR IEC 60079-11. This must be taken into account when installing the apparatus --- see manufacturer's instruction manual.

FISCO (input)	Sensor field terminal (output)
$U_i = 17.5 \text{ V}$	$U_o = 12.5 \text{ V}$
$I_i = 380 \text{ mA}$	$I_o = 4.8 \text{ mA}$
$P_i = 5.32 \text{ W}$	$P_o = 15 \text{ mW}$
$C_i = 2.1 \text{ nF}$	$C_o = 1.2 \mu\text{F}$
$L_i = 0$	$L_o = 1 \text{ H}$

B.9 China

B.9.1 I3 China Intrinsic Safety

Certificate	GYJ21.1125X
Standards	GB3836.1-2010, GB3836.4-2010, GB3836.20-2010
Markings	Ex ia IIC T4/T5 Ga

产品安全使用特殊条件：

产品防爆合格证后缀“X”代表产品安全使用有特殊条件：

输出为 FOUNDATION Fieldbus 时：

1. 温度变送器须安装于外壳防护等级不低于国家标准 GB4208-2008 规定的 IP20 的壳体中，方可用于爆炸性危险场所，金属壳体须符合国家标准 GB3836.1-2010 第 8 条的规定，非金属壳体须符合 GB3836.1-2010 第 7.4 条的规定。
2. 此设备不能承受 GB3836.4-2010 标准中第 6.3.12 条规定的 500V 交流有效值试验电压的介电强度试验。

输出为 Wireless 时：

1. 天线的表面电阻大于 $1 \text{ G}\Omega$ ，不允许用溶剂清洗或用干布擦拭，以避免电荷积聚。
2. 电源模块表面电阻大于 $1 \text{ G}\Omega$ ，必须置于无线设备外壳内使用，现场安装及运输过程中避免电荷积聚。
3. 产品需使用厂家提供的由 2 块 Tadiran TL-5920 Lithium Thionyl-Chloride 原电池组成的电池组。

产品使用注意事项：

1. 产品环境温度为：

输出代码	温度组别	环境温度
F	T4	-50 °C ≤ Ta ≤ + 60 °C
W	T4	-60 °C ≤ Ta ≤ + 70 °C
	T5	-60 °C ≤ Ta ≤ + 40 °C

2. 参数：
供电端 (1-2)

输出代码	最高输入电压	最大输入电流	最大输入功率	最大内部等效参数	
	U _i (V)	I _i (mA)	P _i (mW)	C _i (μF)	L _i (H)
F	30	300	1.3	2.1	0
F (FISCO)	17.5	380	5.32	2.1	0

注 1：上表中非 FISCO 参数必须来自于使用电阻限流的线性输出。

注 2：本安电气参数符合 GB3836.19-2010 对 FISCO 现场仪表的参数要求。当其连接符合 FISCO 模型的电路板时，其本安参数及内部最大等效参数见上表。

传感器端：

输出代码	端子	最高输出电压	最大输出电流	最大输出功率	最大外部等效参数	
		U _o (V)	I _o (mA)	P _o (mW)	C _o (μH)	L _o (H)
F	1-8	12.5	4.8	15	1.2	1
F (FISCO)	1-20	6.6	3.2	5.3	22	1

- 输出代码为 F 时，该产品必须与已通过防爆认证的关联设备配套共同组成本安防爆系统方可使用于爆炸性气体环境。其系统接线必须同时遵守本产品 and 所配关联设备的使用说明书要求，接线端子不得接错。
- 该产品于关联设备的连接电缆应为带绝缘护套的屏蔽电缆，其屏蔽层应为安全接地。
- 用户不得自行更换该产品的零部件，应会同产品制造商共同解决运行中出现的故障，以杜绝损坏现象的发生。产品的安装、使用和维护应同时遵守产品使用说明书、GB3836.13-2013“爆炸性环境 第 13 部分：设备的修理、检修、修复和改造”、GB3836.15-2000“爆炸性气体环境用电气设备 第 15 部分：危险场所电气安装（煤矿除外）”、GB3836.16-2006“爆炸性气体环境用电气设备 第 16 部分：电气装置的检查和维护（煤矿除外）”、GB3836.18-2010“爆炸性环境 第 18 部分：本质安全系统”和 GB50257-2014“电气装置安装工程爆炸和火灾危险环境电力装置施工及验收规范”的有关规定。

B.9.2 N3 China Type n

Certificate	GYJ21.3428U
Standards	GB3836.1-2010, GB3836.8-2014
Markings	Ex nA IIC T4/T5 Gc

产品安全使用特殊条件：

- 设备不能承受 GB3836.8-2014 标准中第 6.5.1 条规定的 500V 耐压试验，安装时必须考虑在内。

2. 此设备必须安装于具有不低于 IP54 外壳防护等级的 Ex 元件外壳，外壳应符合 GB3836.1-2010 和 GB3836.8-2014 标准中对外壳材料和环境的相关要求。
3. 在此设备外部应采取措施以防额定电压因瞬态干扰而超过 40%。

产品使用注意事项：

1. 产品使用环境温度范围：

温度组别	环境温度
T4	$-50\text{ }^{\circ}\text{C} \leq T_a \leq +85\text{ }^{\circ}\text{C}$
T5	$-50\text{ }^{\circ}\text{C} \leq T_a \leq +70\text{ }^{\circ}\text{C}$

2. 最高工作电压：42.4V。
3. 用户不得自行更换该产品的零部件，应会同产品制造商共同解决运行中出现的故障，以杜绝损坏现象的发生。
4. 产品的安装、使用和维护应同时遵守产品使用说明书、GB3836.13-2013“爆炸性环境 第 13 部分：设备的修理、检修、修复和改造”、GB3836.15-2000“爆炸性气体环境用电气设备 第 15 部分：危险场所电气安装（煤矿除外）”、GB3836.16-2006“爆炸性气体环境用电气设备 第 16 部分：电气装置的检查和维护（煤矿除外）”、B50257-2014“电气装置安装工程爆炸和火灾危险环境电力装置施工及验收规范”的有关规定。

B.10 Japan

B.10.1 I4 Japan FISCO Intrinsic Safety (ia)

Certificate	TC19713
Markings	ia IIC T4

B.10.2 Japan Wi-HART Intrinsic Safety (ia)

Certificate	TC19154
Markings	ia IIC T4

B.10.3 H4 Japan FISCO Intrinsic Safety (ib)

Certificate	TC20737
Markings	ia IIC T4

B.11 Korea

B.11.1 IP Korea Intrinsic Safety

Certificate	20-KA4BO-0921X
--------------------	----------------

Markings Ex ia IIC T4 ($-50\text{ °C} \leq T_a \leq +60\text{ °C}$)

B.12 EAC - Belarus, Kazakhstan, Russia

B.12.1 IM Technical Regulation Customs Union (EAC) Intrinsic Safety

Markings [FOUNDATION Fieldbus]: 0Ex ia IIC T4 Ga X, T4($-50\text{ °C} \leq T_a \leq +60\text{ °C}$)
See certificate for entity parameters.

Special Condition for Safe Use (X):

See certificate for special conditions.

B.12.2 IN Technical Regulation Customs Union (EAC) FISCO

Markings: [FISCO]: 0Ex ia IIC T4 Ga X, T4($-50 \leq T_a \leq +60\text{ °C}$)
See certificate for entity parameters.

Special Condition for Safe Use (X):

See certificate for special conditions.

B.13 Combinations

KG Combination of I1/IA, I5/IE, I6/IF, and I7/IG

B.14 Conduit Plugs and Adapters

ATEX Flameproof and Increased Safety

Certificate FM13ATEX0076X
Standards EN 60079-0:2012, EN 60079-1:2007, IEC 60079-7:2007
Markings:  2 G Ex de IIC Gb

Special Conditions for Safe Use (X):

1. When the thread adapter or blanking plug is used with an enclosure in type of protection increased safety “e” the entry thread shall be suitably sealed in order to maintain the ingress protection rating (IP) of the enclosure.
2. The blanking plug shall not be used with an adapter.
3. Blanking Plug and Threaded Adapter shall be either NPT or Metric thread forms. G½ and PG 13.5 thread forms are only acceptable for existing (legacy) equipment installations.

IECEx Flameproof and Increased Safety

Certificate	IECEx FMG 13.0032X
Standards	IEC 60079-0:2011, IEC 60079-1:2007, IEC 60079-7:2006-2007
Markings	Ex de IIC Gb

Special Conditions for Safe Use (X):

1. When the thread adapter or blanking plug is used with an enclosure in type of protection increased safety “e” the entry thread shall be suitably sealed in order to maintain the ingress protection rating (IP) of the enclosure.
2. The blanking plug shall not be used with an adapter.
3. Blanking Plug and Threaded Adapter shall be either NPT or Metric thread forms. G½ and PG 13.5 thread forms are only acceptable for existing (legacy) equipment installations.

Table B-2: Conduit Plug Thread Sizes

Thread	Identification mark
M20 x 1.5	M20
½–14 NPT	½ NPT
G½	G½

Table B-3: Thread Adapter Thread Sizes

Male thread	Identification mark
M20 x 1.5–6H	M20
½–14 NPT	½–14 NPT
¾–14 NPT	¾–14 NPT
Female thread	Identification mark
M20 x 1.5–6H	M20
½–14 NPT	½–14 NPT
PG 13.5	PG 13.5

B.15 Additional Certifications

SBS American Bureau of Shipping (ABS) Type Approval

Certificate	011-HS771994C-1-PDA
ABS Rules	2013 Steel Vessels Rules 1-1-4/7.7, 1-1-Appendix 3, 4-8-3/1.7, 4-8-3/13.1

SBV Bureau Veritas (BV) Type Approval

Certificate	26325/A1 BV
Requirements	Bureau Veritas Rules for the Classification of Steel Ships
Application	Class notations: AUT-UMS, AUT-CCS, AUT-PORT and AUT-IMS

SDN Det Norske Veritas (DNV) Type Approval

Certificate A-13246

Intended Use Det Norske Veritas' Rules for Classification of Ships, High Speed & Light Craft and Det Norske Veritas' Offshore Standards

Applications:

Location classes	
Temperature	D
Humidity	B
Vibration	A
EMC	B
Enclosure	B/IP66: AI C/IP66: SST



I3 Lloyds Register (LR) Type Approval

Certificate 11/60002 (E2)

Application Environmental categories ENV1, ENV2, ENV2 and ENV5

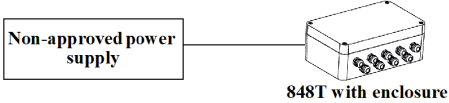
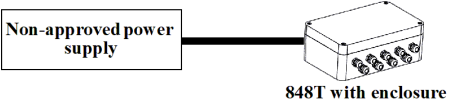
B.16 Intrinsically Safe and Non-Incendive installations

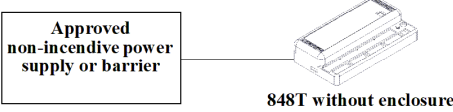
Approval	Safe area	Zone 2 (category 3)	Zone 1 (category 2)	Zone 0 (category 1)
		Division 2	Division 1	
Gas Installations				
I5, I6, I1, I7, IE, IA	Approved I.S. or FISCO barrier	 <p>848T without enclosur</p>		
N1, N7	Non-approved power supply	 <p>848T with enclosure</p>		
N5	Non-approved power supply	 <p>848T with enclosure</p>		

Approval	Safe area	Zone 2 (category 3)	Zone 1 (category 2)	Zone 0 (category 1)
		Division 2	Division 1	
NC	 <p>Approved non-incendive power supply or barrier</p> <p>848T without enclosure</p>			
Dust Installations				
N5, ND	 <p>Non-approved power supply</p> <p>848T with enclosure</p>			
<p>————— Standard cable</p> <p>————— Division 2 wiring</p>				

B.17 Installation drawings

The installation guidelines presented by the drawings must be followed in order to maintain certified ratings for installed transmitters.

Rosemount Drawing 00848-4404, 3 Sheets

Factory Mutual Intrinsic Safety/ FISCO Installation Drawing

Rosemount Drawing 00848-4405, 2 Sheets

Canadian Standards Association Intrinsic Safety/FISCO Installation Drawing

Figure B-1: FM Intrinsic Safety/ FISCO

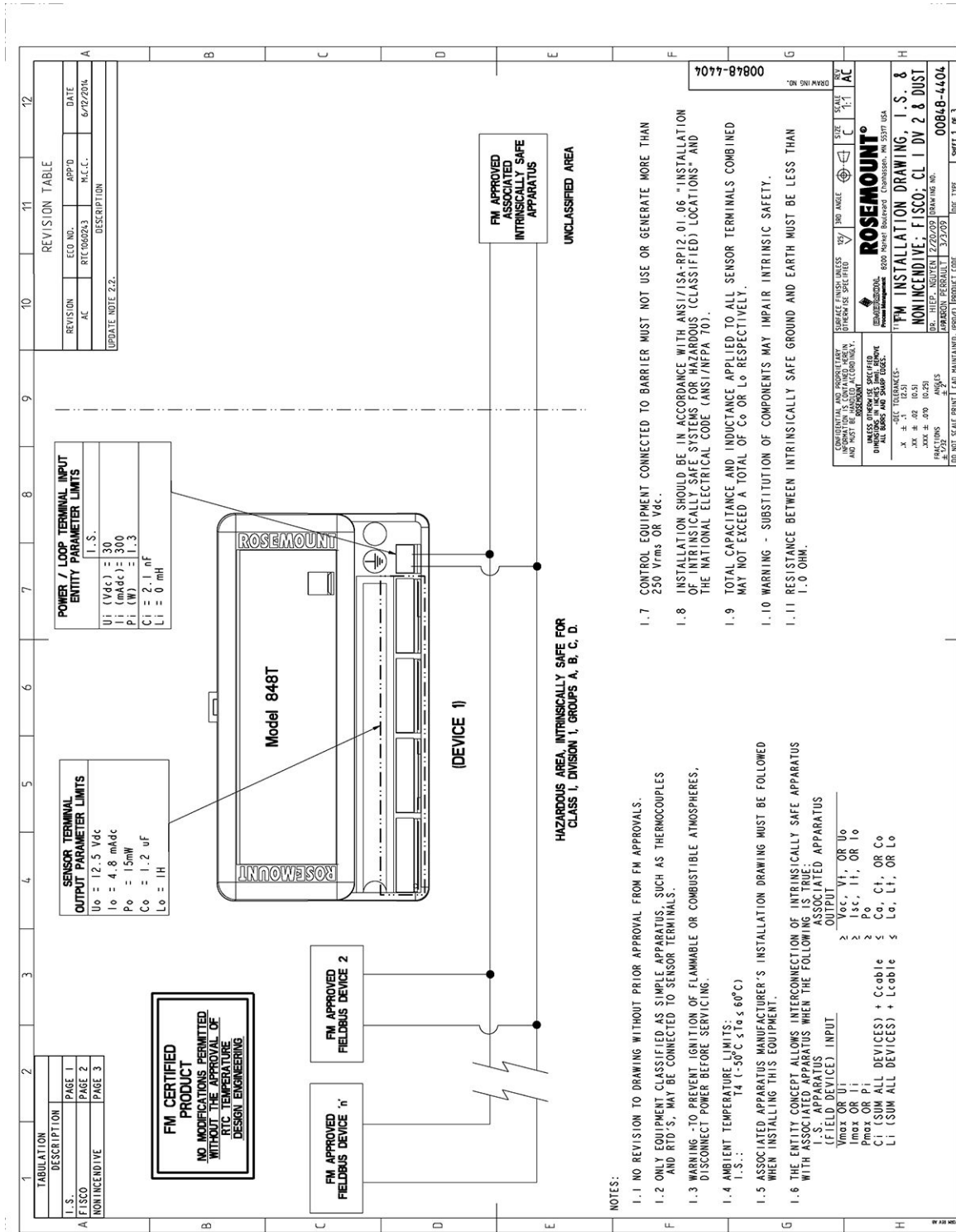

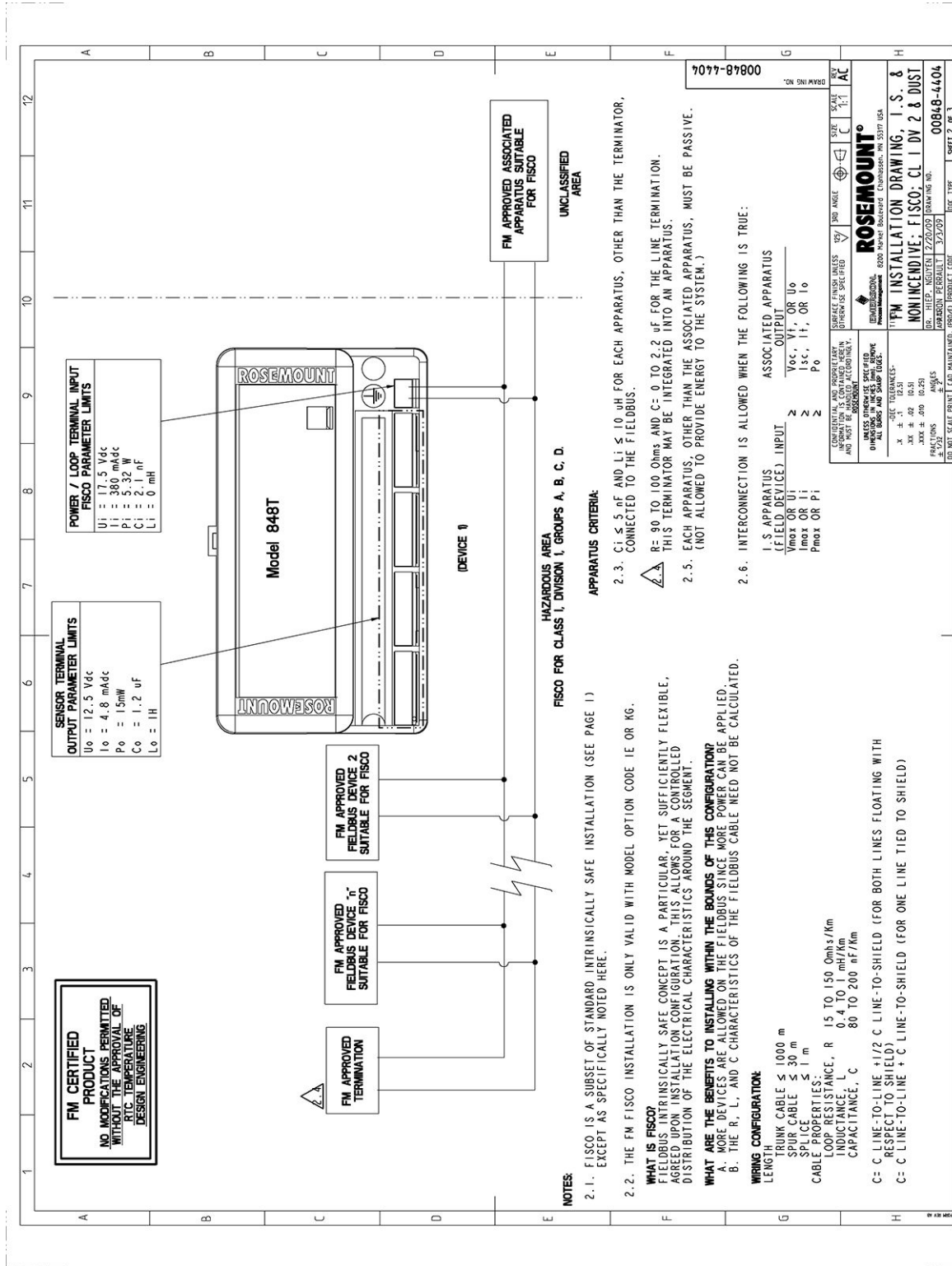

Electronic Master – PRINTED COPIES ARE UNCONTROLLED – Rosemount Proprietary

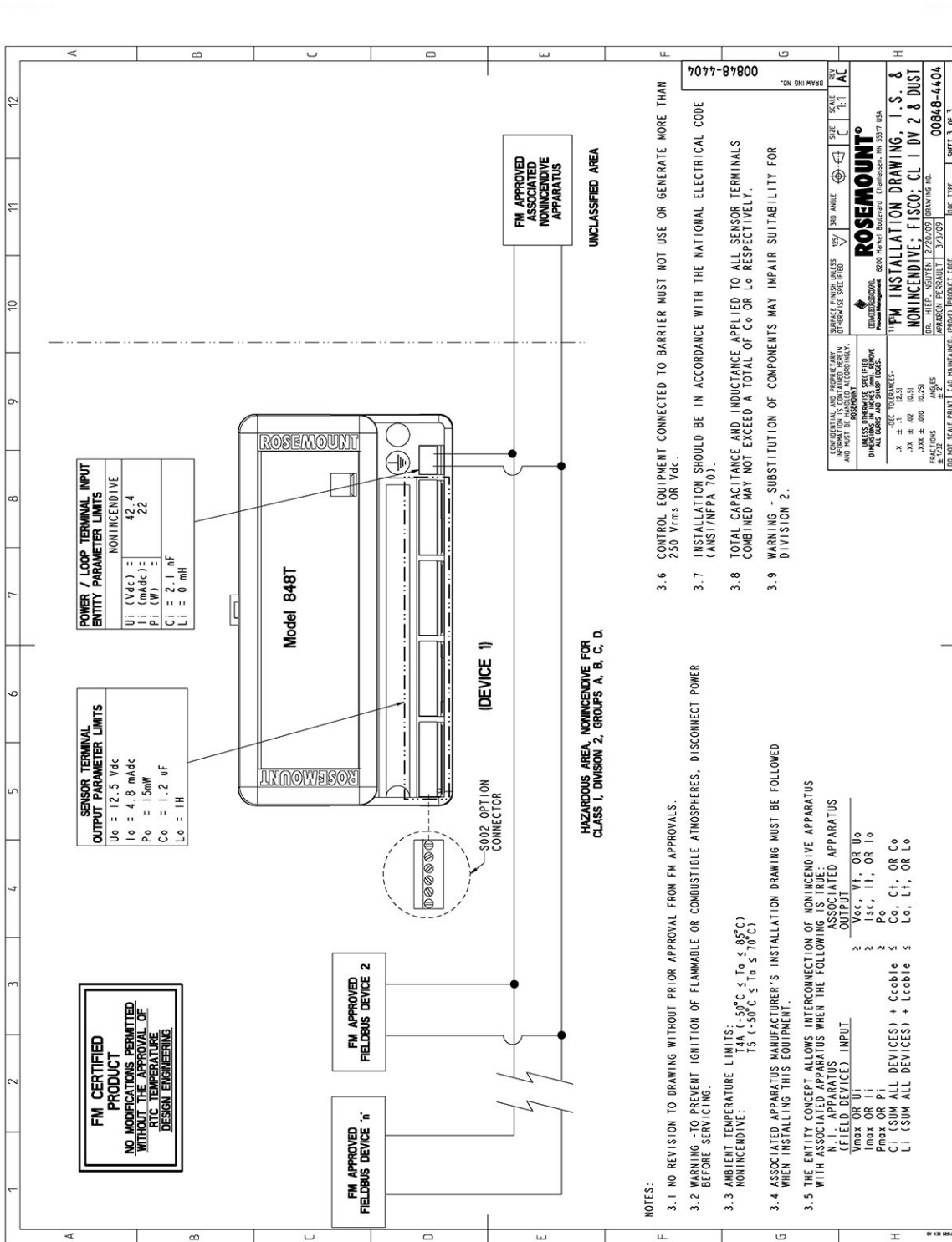

NOTES:

3.1 NO REVISION TO DRAWING WITHOUT PRIOR APPROVAL FROM FM APPROVALS.

3.2 WARNING - TO PREVENT IGNITION OF FLAMMABLE OR COMBUSTIBLE ATMOSPHERES, DISCONNECT POWER BEFORE SERVICING.

3.3 AMBIENT TEMPERATURE LIMITS:
 15 (-50°C ≤ T_a ≤ 85°C)
 15 (-50°C ≤ T_a ≤ 70°C)
 NONINCENDIVE:

3.4 ASSOCIATED APPARATUS MANUFACTURER'S INSTALLATION DRAWING MUST BE FOLLOWED WHEN INSTALLING THIS EQUIPMENT.

3.5 THE ENTITY CONCEPT ALLOWS INTERCONNECTION OF NONINCENDIVE APPARATUS WITH ASSOCIATED APPARATUS WHEN THE FOLLOWING IS TRUE:
 N.I. APPARATUS ASSOCIATED APPARATUS
 (FIELD DEVICE) INPUT OUTPUT
 V_{max} OR U_i ≥ V_{oc}, V_i, OR U_o
 I_{max} OR I_i ≥ I_{sc}, I_i, OR I_o
 P_{max} OR P_i ≥ P_o
 C_i (SUM ALL DEVICES) + C_{cable} ≤ C_a, C_i, OR C_o
 L_i (SUM ALL DEVICES) + L_{cable} ≤ L_a, L_i, OR L_o

3.6 CONTROL EQUIPMENT CONNECTED TO BARRIER MUST NOT USE OR GENERATE MORE THAN 250 Vrms OR Vdc.

3.7 INSTALLATION SHOULD BE IN ACCORDANCE WITH THE NATIONAL ELECTRICAL CODE (ANSI/NFPA 70).

3.8 TOTAL CAPACITANCE AND INDUCTANCE APPLIED TO ALL SENSOR TERMINALS COMBINED MAY NOT EXCEED A TOTAL OF C_o OR L_o RESPECTIVELY.

3.9 WARNING - SUBSTITUTION OF COMPONENTS MAY IMPAIR SUITABILITY FOR DIVISION 2.

7077-87800
DRAWING NO.

SCALE: 1:1
SIZE: C

ROSEMOUNT
Process Management
8200 Havel Boulevard, Chesham, NJ 08817 USA

FM INSTALLATION DRAWING, I.S. & NONINCENDIVE - FISCO: CL 1 DIV 2 & DUST

REVISED: 02/2019
DRAWING NO.: 00848-4404

DO NOT SCALE PRINT. LAD MAINTAINED. PRODUCT CODE: 00848-4404
SHEET 3 OF 3

Electronic Master - PRINTED COPIES ARE UNCONTROLLED - Rosemount Proprietary

Figure B-2: CSA Intrinsic Safety/ FISCO

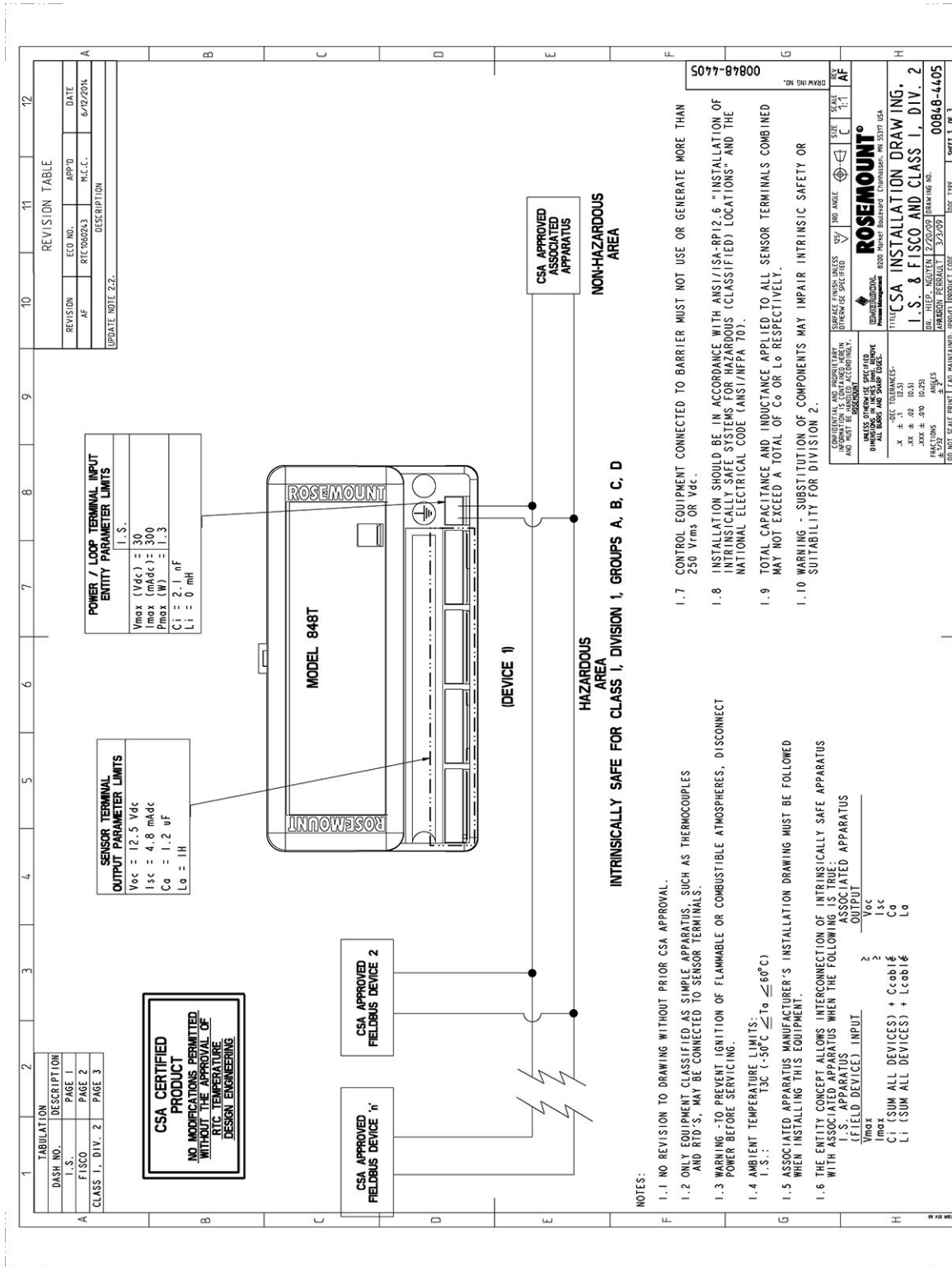

Electronic Master - PRINTED COPIES ARE UNCONTROLLED - Rosemount Proprietary

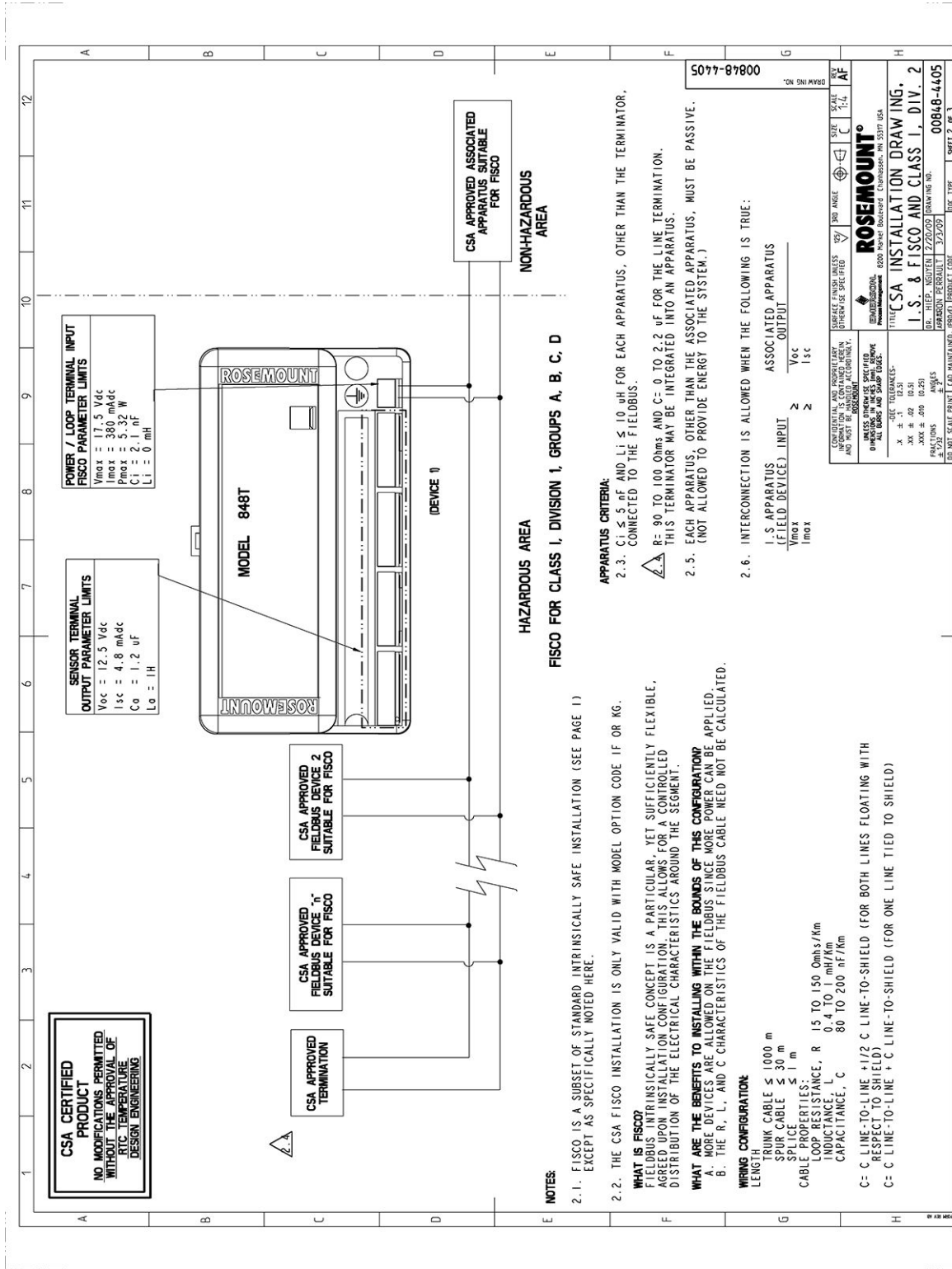

Electronic Master - PRINTED COPIES ARE UNCONTROLLED - Rosemount Proprietary

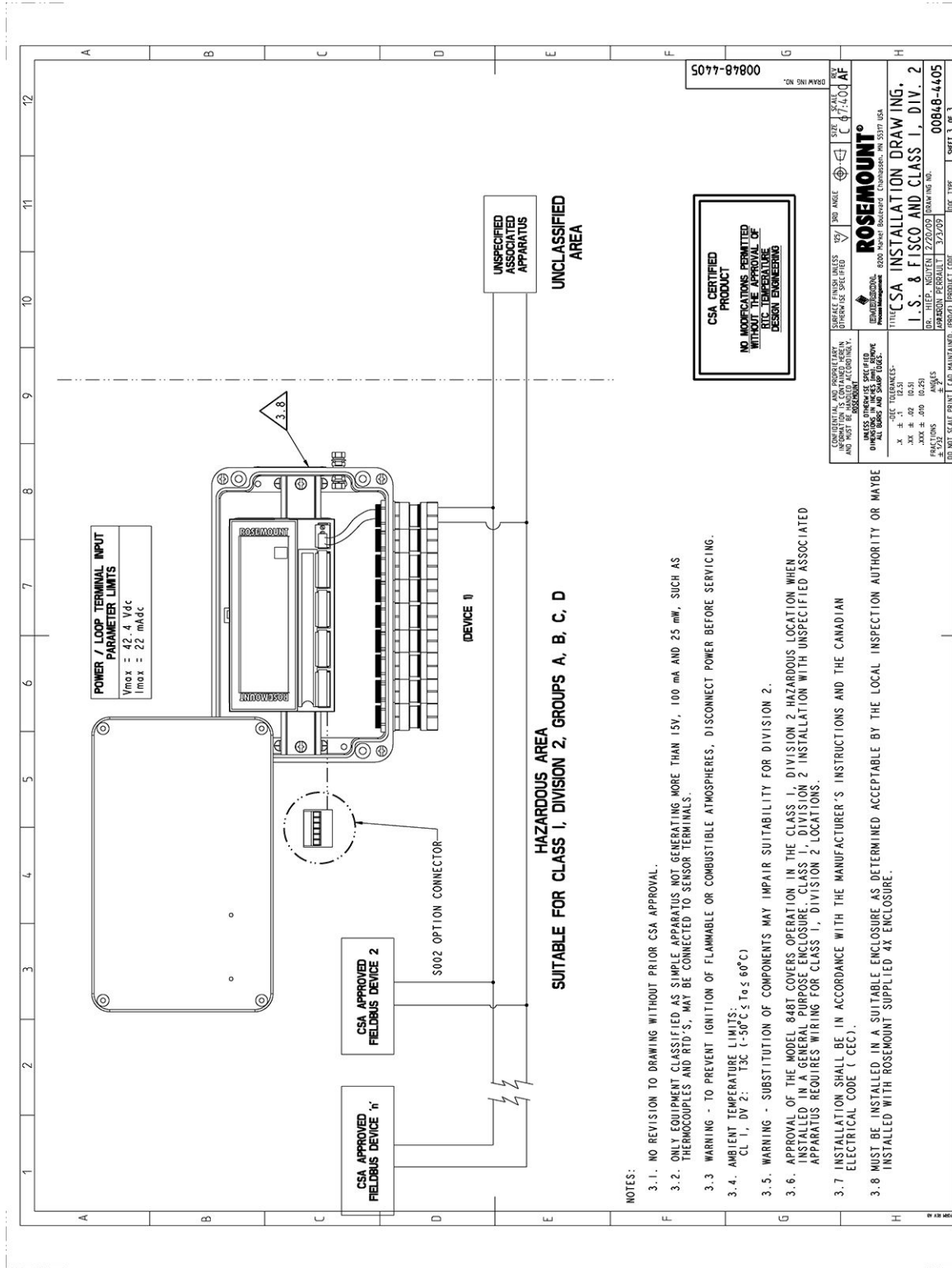

Electronic Master - PRINTED COPIES ARE UNCONTROLLED - Rosemount Proprietary

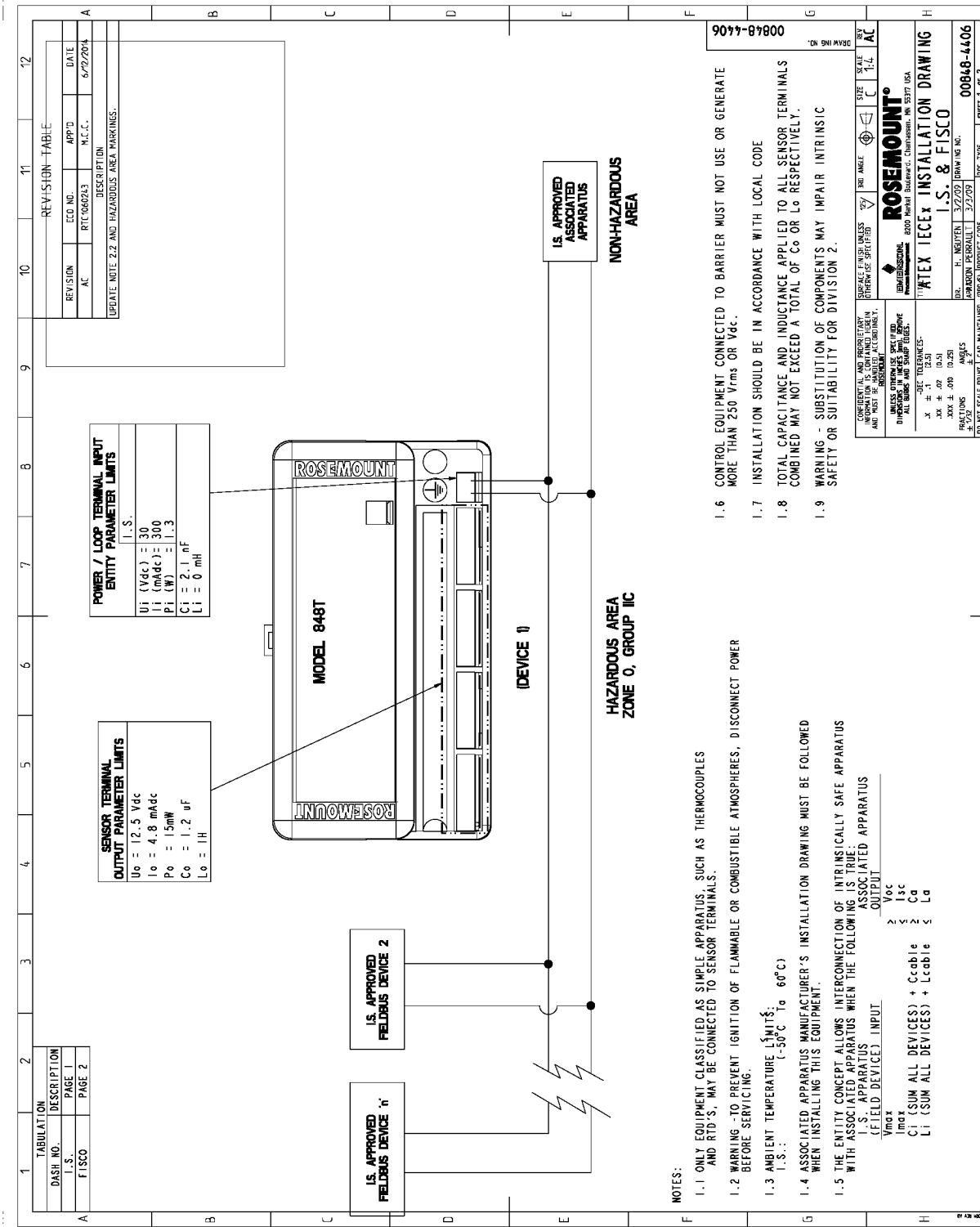

- NOTES:**
- 1.1 ONLY EQUIPMENT CLASSIFIED AS SIMPLE APPARATUS, SUCH AS THERMOCOUPLES AND RTD'S, MAY BE CONNECTED TO SENSOR TERMINALS.
 - 1.2 WARNING - TO PREVENT IGNITION OF FLAMMABLE OR COMBUSTIBLE ATMOSPHERES, DISCONNECT POWER BEFORE SERVICING.
 - 1.3 AMBIENT TEMPERATURE LIMITS:
I.S.: (-50°C To 60°C)
 - 1.4 ASSOCIATED APPARATUS MANUFACTURER'S INSTALLATION DRAWING MUST BE FOLLOWED WHEN INSTALLING THIS EQUIPMENT.
 - 1.5 THE ENTITY CONCEPT ALLOWS INTERCONNECTION OF INTRINSICALLY SAFE APPARATUS WITH ASSOCIATED APPARATUS WHEN THE FOLLOWING IS TRUE:
I.S. APPARATUS ASSOCIATED APPARATUS
(FIELD DEVICE) INPUT OUTPUT
Vmax ≥ Vdc
Imax ≥ Isc
Ci (SUM ALL DEVICES) + Ccable ≥ Ca
Li (SUM ALL DEVICES) + Lcable ≥ La

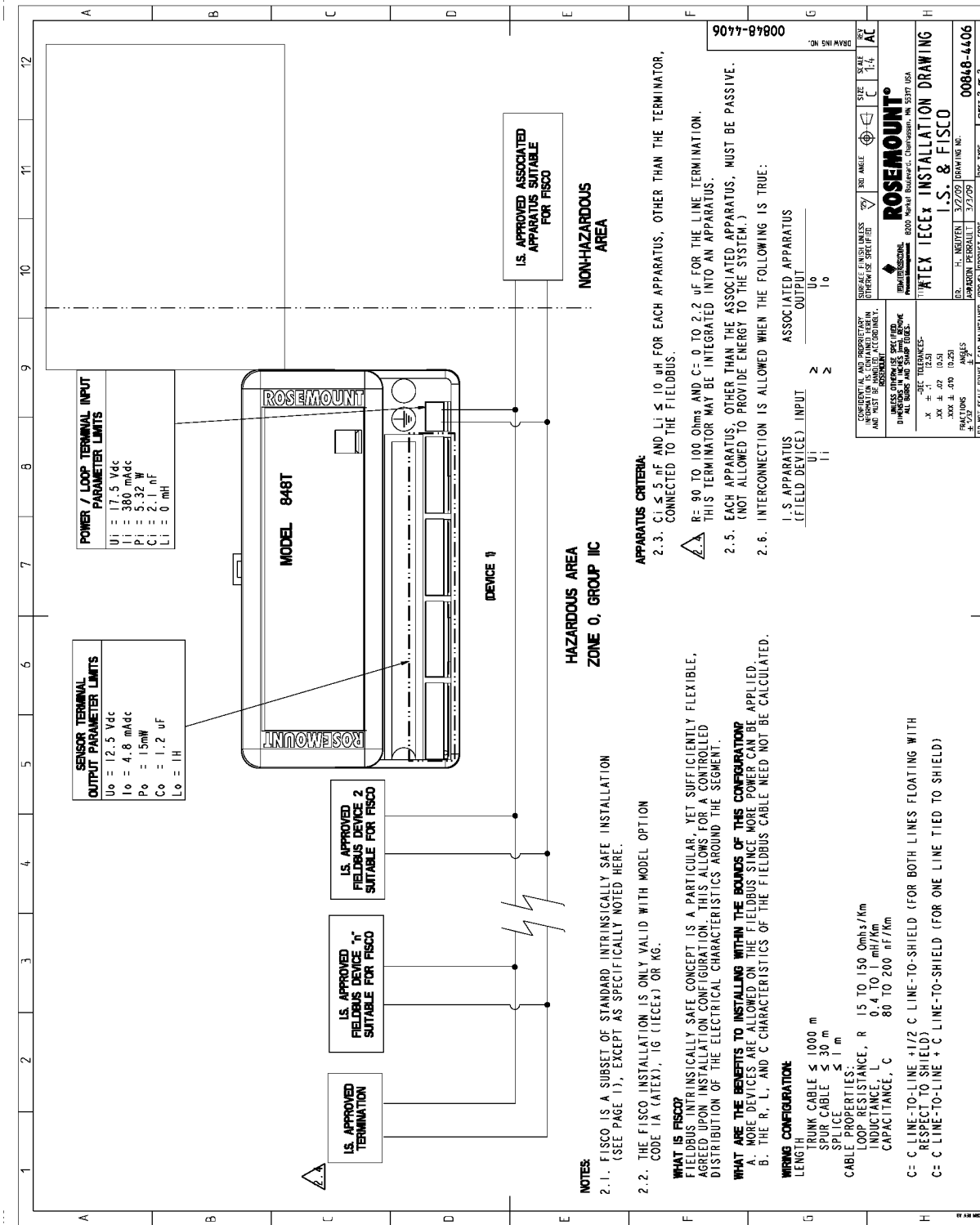

C FOUNDATION Fieldbus technology

C.1 Overview

FOUNDATION™ Fieldbus is an all-digital, serial, two-way, multi-drop communication protocol that interconnects devices such as transmitters, sensors, actuators, and valve controllers. Fieldbus is a Local Area Network (LAN) for instruments that are used in both process and manufacturing automation, having the built-in capability to distribute the control applications across the network. The fieldbus environment is the base level group of digital networks and the hierarchy of plant networks.

The FOUNDATION Fieldbus retains the desirable features of the 4–20 mA analog system, including standardized physical interface to the wire, bus-powered devices on a single pair of wires, and intrinsic safety options. It also enables the following capabilities:

- Increased capabilities due to full digital communication
- Reduced wiring and wire terminations due to multiple devices on one pair of wires
- Increased supplier selection due to interoperability
- Reduced loading on control room equipment due to the distribution of some control and input/output functions to field devices

FOUNDATION Fieldbus devices work together to provide I/O and control for automated processes and operations. The Fieldbus Foundation provides a framework for describing these systems as a collection of physical devices interconnected by a fieldbus network. One of the ways that the physical devices are used is to perform their portion of the total system operation by implementing one or more function blocks.

C.2 Function blocks

Function blocks perform process control functions, such as analog input (AI) and analog output (AO) functions as well as proportional-integral-derivative (PID) functions. The standard function blocks provide a common structure for defining function block inputs, outputs, control parameters, events, alarms, and modes, and combining them into a process that can be implemented within a single device or over the fieldbus network. This simplifies the identification of characteristics that are common to function blocks.

The Fieldbus Foundation has established the function blocks by defining a small set of parameters used in all function blocks called universal parameters. The FOUNDATION™ Fieldbus has also defined a standard set of function block classes, such as input, output, control, and calculation blocks. Each of these classes has a small set of parameters established for it. They have also published definitions for transducer blocks commonly used with standard function blocks. Examples include temperature, pressure, level, and flow transducer blocks.

The Fieldbus Foundation specifications and definitions allow vendors to add their own parameters by importing and subclassing specified classes. This approach permits extending function block definitions as new requirements are discovered and as technology advances.

Figure C-1 illustrates the internal structure of a function block. When execution begins, input parameter values from other blocks are snapped-in by the block. The input snap process ensures that these values do not change during the block execution. New values received for these parameters do not affect the snapped values and will not be used by the function block during the current execution.

Figure C-1: Function block internal structure

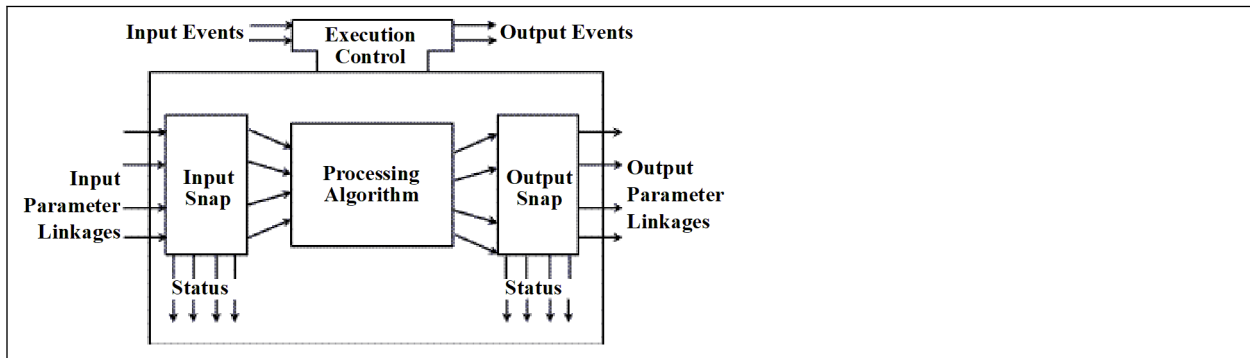

Once the inputs are snapped, the algorithm operates on them, generating outputs as it progresses. Algorithm executions are controlled through the setting of contained parameters. Contained parameters are internal to function blocks and do not appear as normal input and output parameters. However, they may be accessed and modified remotely, as specified by the function block.

Input events may affect the operation of the algorithm. An execution control function regulates the receipt of input events and the generation of output events during execution of the algorithm. Upon completion of the algorithm, the data internal to the block is saved for use in the next execution, and the output data is snapped, releasing it for use by other function blocks.

A block is a tagged logical processing unit. The tag is the name of the block. System management services locate a block by its tag. Thus the service personnel need only know the tag of the block to access or change the appropriate block parameters.

Function blocks are also capable of performing short-term data collection and storage for reviewing their behavior.

C.3 Device descriptions

Device Descriptions (DD) are specified tool definitions that are associated with the resource and transducer blocks. Device Descriptions provide the definition and description of the function blocks and their parameters.

To promote consistency of definition and understanding, descriptive information, such as data type and length, is maintained in the device description. Device Descriptions are written using an open language called the Device Description Language (DDL). Parameter transfers between function blocks can be easily verified because all parameters are described using the same language. Once written, the device description can be stored on an external medium, such as a CD-ROM or diskette. Users can then read the device description from the external medium. The use of an open language in the device description permits interoperability of function blocks within devices from various vendors. Additionally, human interface devices, such as operator consoles and computers, do not have to be programmed specifically for each type of device on the bus. Instead their displays and interactions with devices are driven from the device descriptions.

Device Descriptions may also include a set of processing routines called methods. Methods provide a procedure for accessing and manipulating parameters within a device.

C.4 Block operation

In addition to function blocks, fieldbus devices contain two other block types to support the function blocks. These are the resource block and the transducer block.

C.4.1 Instrument- specific function blocks

Resource blocks

Resource blocks contain the hardware-specific characteristics associated with a device; they have no input or output parameters. The algorithm within a resource block monitors and controls the general operation of the physical device hardware. The execution of this algorithm is dependent on the characteristics of the physical device, as defined by the manufacturer. As a result, the algorithm may cause the generation of events. There is only one resource block defined for a device. For example, when the mode of a resource block is Out of Service (OOS), it impacts all of the other blocks.

Transducer blocks

Transducer blocks connect function blocks to local input/output functions. They read sensor hardware and write to effector (actuator) hardware. This permits the transducer block to execute as frequently as necessary to obtain good data from sensors and ensure proper writes to the actuator without burdening the function blocks that use the data. The transducer block also isolates the function block from the vendor-specific characteristics of the physical I/O.

C.4.2 Alerts

When an alert occurs, execution control sends an event notification and waits a specified period of time for an acknowledgment to be received. This occurs even if the condition that caused the alert no longer exists. If the acknowledgment is not received within the pre-specified time-out period, the event notification is retransmitted, assuring that alert messages are not lost.

Two types of alerts are defined for the block: events and alarms. Events are used to report a status change when a block leaves a particular state, such as when a parameter crosses a threshold. Alarms not only report a status change when a block leaves a particular state, but also report when it returns back to that state.

C.5 Network communication

Figure C-2 illustrates a simple fieldbus network consisting of a single segment (link).

Figure C-2: Simple, single-link fieldbus network

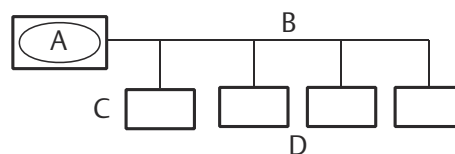

- A. Link Active Scheduler (LAS)
- B. Fieldbus link
- C. Link master
- D. Basic device and/or link master devices

C.5.1 LAS

All links have one LAS that operates as the bus arbiter for the link. The LAS does the following:

- Recognizes and adds new devices to the link
- Removes non-responsive devices from the link
- Distributes Data Link Time (DL) and Link Scheduling Time (LS) on the link
 - DL is a network-wide time periodically distributed by the LAS to synchronize all device clocks on the bus.
 - LS time is a link-specific time represented as an offset from DL. It is used to indicate when the LAS on each link begins and repeats its schedule. It is used by system management to synchronize function block execution with the data transfers scheduled by the LAS.
- Polls devices for process loop data at scheduled transmission times
- Distributes a priority-driven token to devices between scheduled transmissions

Any device on the link may become the LAS. The devices that are capable of becoming the LAS are called Link Master devices (LM). All other devices are referred to as basic devices. When a segment first starts up, or upon failure of the existing LAS, the link master devices on the segment bid to become the LAS. The link master that wins the bid begins operating as the LAS immediately upon completion of the bidding process. Link masters that do not become the LAS act as basic devices. However, the link masters can act as LAS backups by monitoring the link for failure of the LAS and then bidding to become the LAS when a LAS failure is detected.

Only one device can communicate at a time. Permission to communicate on the bus is controlled by a centralized token passed between devices by the LAS. Only the device with the token can communicate. The LAS maintains a list of all devices that need access to the bus. This list is called the *Live List*.

Two types of tokens are used by the LAS. A time-critical token, Compel Data (CD), is sent by the LAS according to a schedule. A non-time critical token, pass token (PT), is sent by the LAS to each device in ascending numerical order according to address.

There may be many LM devices on a segment but only the LAS is actively controlling communication traffic. The remaining LM devices on the segment are in a stand-by state, ready to take over if the primary LAS fails. This is achieved by constantly monitoring the communication traffic on the bus and determining if activity is not present. Since there can be multiple LM devices on the segment when the primary LAS fails, the device with the lowest node address will become the primary LAS and take control of the bus. Using this strategy, multiple LAS failures can be handled with no loss of the LAS capability of the communications bus.

LAS parameters

There are many bus communication parameters but only a few are used. For standard RS-232 communications, the configuration parameters are baud rate, start/stop bits, and parity. The key parameters for H1 FOUNDATION™ Fieldbus are as follows.

- **Slot Time (ST)** – Used during the bus master election process. It is the maximum amount of time permitted for device A to send a message to device B. Slot time is a parameter which defines a worst case delay which includes internal delay in the sending device and the receiving device. Increasing the value of ST slows down bus traffic because a LAS device must wait longer prior to determining that the LM is down.
- **Minimum Inter-PDU Delay (MID)** – The minimum gap between two messages on the fieldbus segment or it is the amount of time between the last byte of one message and the first byte of the next message. The units of the MID are octets. An octet is 256 μ s, hence the units for MID are approximately 1/4 ms. This would mean an MID of 16 would specify approximately a minimum of 4 ms between messages on the

fieldbus. Increasing the value of MID slows down bus traffic because a larger “gap” between messages occurs.

- **Maximum Response (MRD)** – Defines the maximum amount of time permitted to respond to an immediate response request, e.g. CD, PT. When a published value is requested using the CD command, the MRD defines how long before the device publishes the data. Increasing this parameter will slow down the bus traffic by decreasing how fast CDs can be put onto the network. The MRD is measured in units of ST.
- **Time Synchronization Class (TSC)** – A variable that defines how long the device can estimate its time before drifting out of specific limits. The LM will periodically send out time update messages to synchronize devices on the segment. Decreasing the parameter number increases the number of times that time distribution messages must be published, increasing bus traffic and overhead for the LM device. See [Figure C-3](#).

Figure C-3: LAS parameter diagram



Backup LAS

An LM device is one that has the ability to control the communications on the bus. The LAS is the LM capable device that is currently in control of the bus. While there can be many LM devices acting as backups, there can only be one LAS. The LAS is typically a host system but for stand-alone applications, a device may be providing the role of primary LAS.

C.5.2 Addressing

To setup, configure, and communicate with other devices on a segment, a device must be assigned a permanent address. Unless requested otherwise, it is assigned a temporary address when shipped from the factory.

FOUNDATION™ Fieldbus uses addresses between 0 and 255. Addresses 0 through 15 are reserved for group addressing and for use by the data link layer.

If there are two or more devices on a segment with the same address, the first device to start up will use the assigned address. Each of the other devices will be given one of the four temporary addresses. If a temporary address is not available, the device will be unavailable until a temporary address is available.

Use the host system documentation to commission a device and assign a permanent address.

C.5.3 Scheduled transfers

Information is transferred between devices over the FOUNDATION™ Fieldbus using three different types of reporting.

Publisher/subscriber

This type of reporting is used to transfer critical process loop data, such as the process variable. The data producers (publishers) post the data in a buffer that is transmitted to the subscriber, when the publisher receives the Compel Data (CD). The buffer contains only one copy of the data. New data completely

overwrites previous data. Updates to published data are transferred simultaneously to all subscribers in a single broadcast. Transfers of this type can be scheduled on a precisely periodic basis.

Report distribution

This type of reporting is used to broadcast and multi-cast event and trend reports. The destination address may be predefined so that all reports are sent to the same address, or it may be provided separately with each report. Transfers of this type are queued. They are delivered to the receivers in the order transmitted, although there may be gaps due to corrupted transfers. These transfers are unscheduled and occur between scheduled transfers at a given priority.

Client/server

This type of reporting is used for request/response exchanges between pairs of devices. Like Report Distribution reporting, the transfers are queued, unscheduled, and prioritized. Queued means the messages are sent and received in the order submitted for transmission, according to their priority, without overwriting previous messages. However, unlike Report Distribution, these transfers are flow controlled and employ a retransmission procedure to recover from corrupted transfers.

Figure C-4 illustrates the method of scheduled data transfer. Scheduled data transfers are typically used for the regular cyclic transfer of process loop data between devices on the fieldbus. Scheduled transfers use publisher/ subscriber type of reporting for data transfer. The LAS maintains a list of transmit times for all publishers in all devices that need to be cyclically transmitted. When it is time for a device to publish data, the LAS issues a CD message to the device. Upon receipt of the CD, the device broadcasts or “publishes” the data to all devices on the fieldbus. Any device that is configured to receive the data is called a “subscriber.”

Figure C-4: Scheduled data transfer

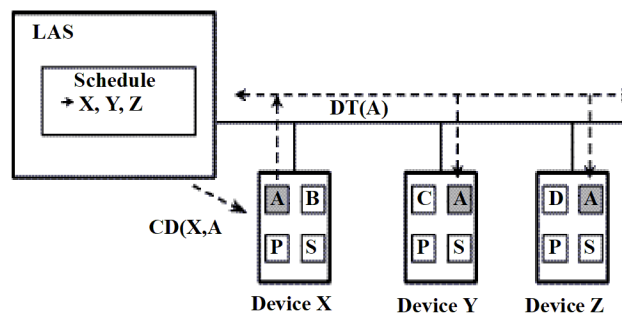

LAS = Link Active Scheduler
P = Publisher
S = Subscriber
CD = Compel Data
DT = Data Transfer Packet

C.5.4 Unscheduled transfers

Figure C-5 diagrams an unscheduled transfer. Unscheduled transfers are used for things like user-initiated changes, including set point changes, mode changes, tuning changes, and upload/download. Unscheduled transfers use either report distribution or client/server type of reporting for transferring data.

All of the devices on the FOUNDATION™ Fieldbus are given a chance to send unscheduled messages between transmissions of scheduled data. The LAS grants permission to a device to use the fieldbus by issuing a pass

token (PT) message to the device. When the device receives the PT, it is allowed to send messages until it has finished or until the maximum token hold time has expired, whichever is the shorter time. The message may be sent to a single destination or to multiple destinations.

Figure C-5: Unscheduled data transfer

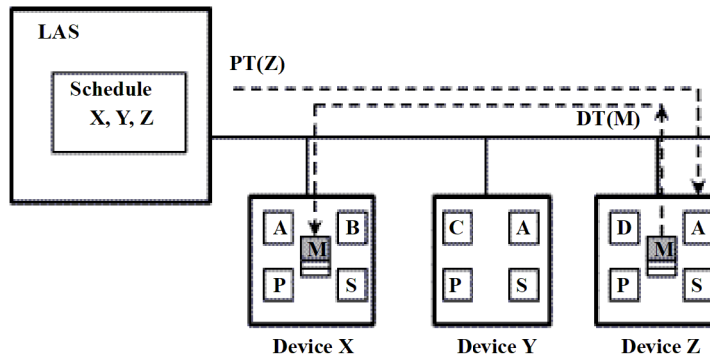

P = Publisher
S = Subscriber
PT = Pass Token
M = Message

C.5.5 Function block scheduling

Figure C-6 shows an example of a link schedule. A single iteration of the link-wide schedule is called the macrocycle. When the system is configured and the function blocks are linked, a master link-wide schedule is created for the LAS. Each device maintains its portion of the link-wide schedule, known as the Function Block Schedule. The Function Block Schedule indicates when the function blocks for the device are to be executed. The scheduled execution time for each function block is represented as an offset from the beginning of the macrocycle start time.

Figure C-6: Example link schedule showing scheduled and unscheduled communication

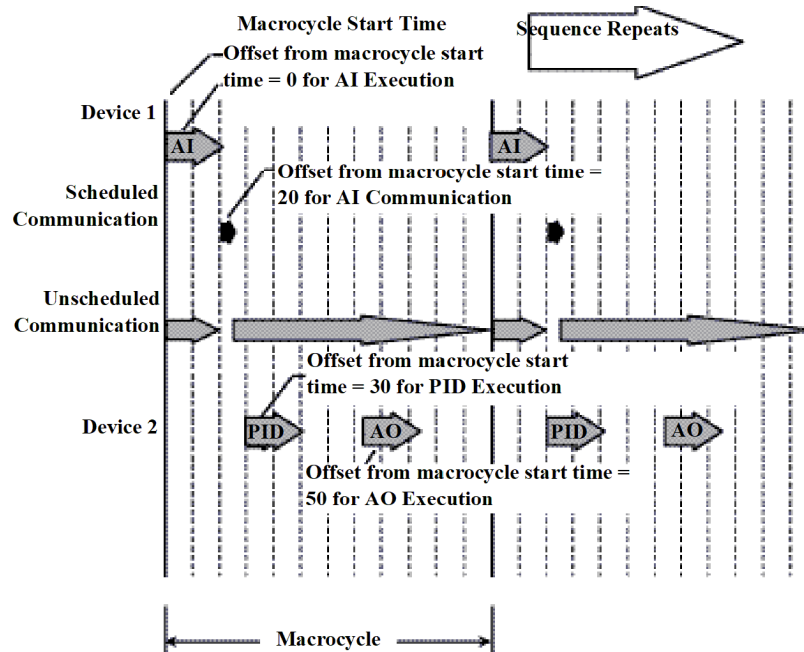

To support synchronization of schedules, periodically Link Scheduling (LS) time is distributed. The beginning of the macrocycle represents a common starting time for all Function Block schedules on a link and for the LAS link-wide schedule. This permits function block executions and their corresponding data transfers to be synchronized in time.

D Function blocks

D.1 Analog Input (AI) function block

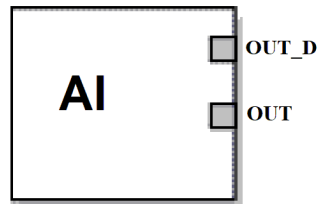

Out = The block output value and status

Out_D = Discrete output that signals a selected alarm condition

The Analog Input (AI) function block processes field device measurements and makes them available to other function blocks. The output value from the AI block is in engineering units and contains a status indicating the quality of the measurement. The measuring device may have several measurements or derived values available in different channels. Use the channel number to define the variable that the AI block processes.

The AI block supports alarming, signal scaling, signal filtering, signal status calculation, mode control, and simulation. In Automatic mode, the block's output parameter (OUT) reflects the process variable (PV) value and status. In Manual mode, OUT may be set manually. The Manual mode is reflected on the output status. A discrete output (OUT_D) is provided to indicate whether a selected alarm condition is active. Alarm detection is based on the OUT value and user specified alarm limits. The block execution time is 30 ms.

Table D-1: Analog Input function block parameters

Number	Parameter	Units	Description
01	ST_REV	None	The revision level of the static data associated with the function block. The revision value will be incremented each time a static parameter value in the block is changed.
02	TAG_DESC	None	The user description of the intended application of the block.
03	STRATEGY	None	The strategy field can be used to identify a grouping of blocks. This data is not checked or processed by the block.
04	ALERT_KEY	None	The identification number of the plant unit. This information may be used in the host for sorting alarms, etc.
05	MODE_BLK	None	The actual, target, permitted, and normal modes of the block. Actual: The mode the block is currently in Target: The mode to "go to" Permitted: Allowed modes that target may "take on" Normal: Most common mode for target

Table D-1: Analog Input function block parameters (continued)

Number	Parameter	Units	Description
06	BLOCK_ERR	None	This parameter reflects the error status associated with the hardware or software components associated with a block. It is a bit string, so that multiple errors may be shown.
07	PV	EU of XD_SCALE	The process variable used in block execution.
08	OUT	EU of OUT_SCALE or XD_SCALE if in direct L_TYPE	The block output value and status.
09	SIMULATE	None	A group of data that contains the current transducer value and status, the simulated transducer value and status, and the enable/disable bit.
10	XD_SCALE	None	The high and low scale values, engineering units code, and number of digits to the right of the decimal point associated with the channel input value. The XD_SCALE units code must match the units code of the measurement channel in the transducer block. If the units do not match, the block will not transition to MAN or AUTO.
11	OUT_SCALE	None	The high and low scale values, engineering units code, and number of digits to the right of the decimal point associated with OUT when L_TYPE is not direct.
12	GRANT_DENY	None	Options for controlling access of host computers and local control panels to operating, tuning, and alarm parameters of the block. Not used by device.
13	IO_OPTS	None	Allows the selection of input/output options used to alter the PV. Low cutoff enabled is the only selectable option.
14	STATUS_OPTS	None	Allows the user to select options for status handling and processing. The options supported in the AI block are the following: Propagate fault forward Uncertain if limited Bad if limited Uncertain if Manual mode.
15	CHANNEL	None	The CHANNEL value is used to select the measurement value. Configure the CHANNEL parameter before configuring the XD_SCALE parameter. Refer to Table 3-5 .
16	L_TYPE	None	Linearization type. Determines whether the field value is used directly (Direct), is converted linearly (Indirect), or is converted with the square root (Indirect Square Root).
17	LOW_CUT	%	If percentage value of transducer input fails below this, PV = 0.
18	PV_FTIME	Seconds	The time constant of the first-order PV filter. It is the time required for a 63% change in the PV or OUT value.

Table D-1: Analog Input function block parameters (continued)

Number	Parameter	Units	Description
19	FIELD_VAL	Percent	The value and status from the transducer block or from the simulated input when simulation is enabled.
20	UPDATE_EVT	None	This alert is generated by any change to the static data.
21	BLOCK_ALM	None	The block alarm is used for all configuration, hardware, connection failure or system problems in the block. The cause of the alert is entered in the subcode field. The first alert to become active will set the Active status in the Status parameter. As soon as the Unreported status is cleared by the alert reporting task, another block alert may be reported without clearing the Active status, if the subcode has changed.
22	ALARM_SUM	None	The summary alarm is used for all process alarms in the block. The cause of the alert is entered in the subcode field. The first alert to become active will set the Active status in the Status parameter. As soon as the Unreported status is cleared by the alert reporting task, another block alert may be reported without clearing the Active status, if the subcode has changed.
23	ACK_OPTION	None	Used to set auto acknowledgment of alarms.
24	ALARM_HYS	Percent	The amount the alarm value must return within the alarm limit before the associated active alarm condition clears.
25	HI_HI_PRI	None	The priority of the HI HI alarm.
26	HI_HI_LIM	EU of PV_SCALE	The setting for the alarm limit used to detect the HI HI alarm condition.
27	HI_PRI	None	The priority of the HI alarm.
28	HI_LIM	EU of PV_SCALE	The setting for the alarm limit used to detect the HI alarm condition.
29	LO_PRI	None	The priority of the LO alarm.
30	LO_LIM	EU of PV_SCALE	The setting for the alarm limit used to detect the LO alarm condition.
31	LO_LO_PRI	None	The priority of the LO LO alarm.
32	LO_LO_LIM	EU of PV_SCALE	The setting for the alarm limit used to detect the LO LO alarm condition.
33	HI_HI_ALM	None	The HI HI alarm data, which includes a value of the alarm, a timestamp of occurrence and the state of the alarm.
34	HI_ALM	None	The HI alarm data, which includes a value of the alarm, a timestamp of occurrence and the state of the alarm.
35	LO_ALM	None	The LO alarm data, which includes a value of the alarm, a timestamp of occurrence and the state of the alarm.

Table D-1: Analog Input function block parameters (continued)

Number	Parameter	Units	Description
36	LO_LO_ALM	None	The LO LO alarm data, which includes a value of the alarm, a timestamp of occurrence and the state of the alarm.
37	OUT_D	None	Discrete output to indicate a selected alarm condition.
38	ALM_SEL	None	Used to select the process alarm conditions that will cause the OUT_D parameter to be set.
39	STDDEV	% of OUT Range	Standard deviation of the measurement for 100 macrocycles.
40	CAP_STDDEV	% of OUT Range	Capability standard deviation, the best deviation that can be achieved.

D.1.1 Functionality

Simulation

To support testing, either change the mode of the block to manual and adjust the output value, or enable simulation through the configuration tool and manually enter a value for the measurement value and its status. In simulation, the ENABLE jumper must be set on the field device.

Note

All FOUNDATION™ Fieldbus instruments have a simulation jumper. As a safety measure, the jumper has to be reset every time there is a power interruption. This measure is to prevent devices that went through simulation in the staging process from being installed with simulation enabled.

With simulation enabled, the actual measurement value has no impact on the OUT value or the status.

Figure D-1: Analog Input function block timing diagram

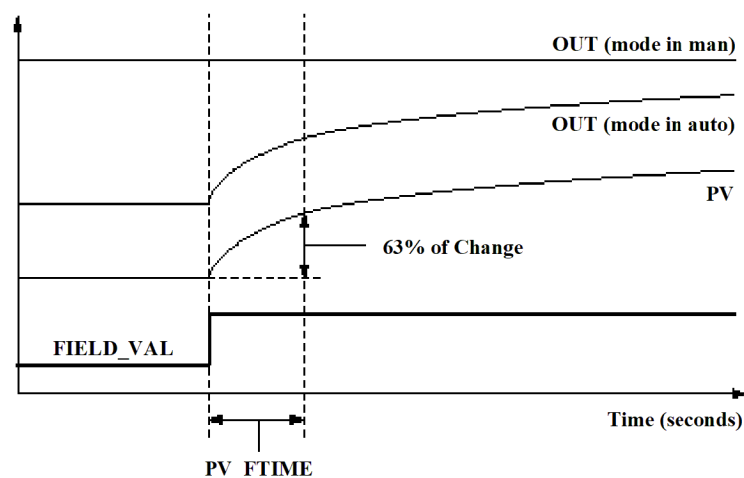
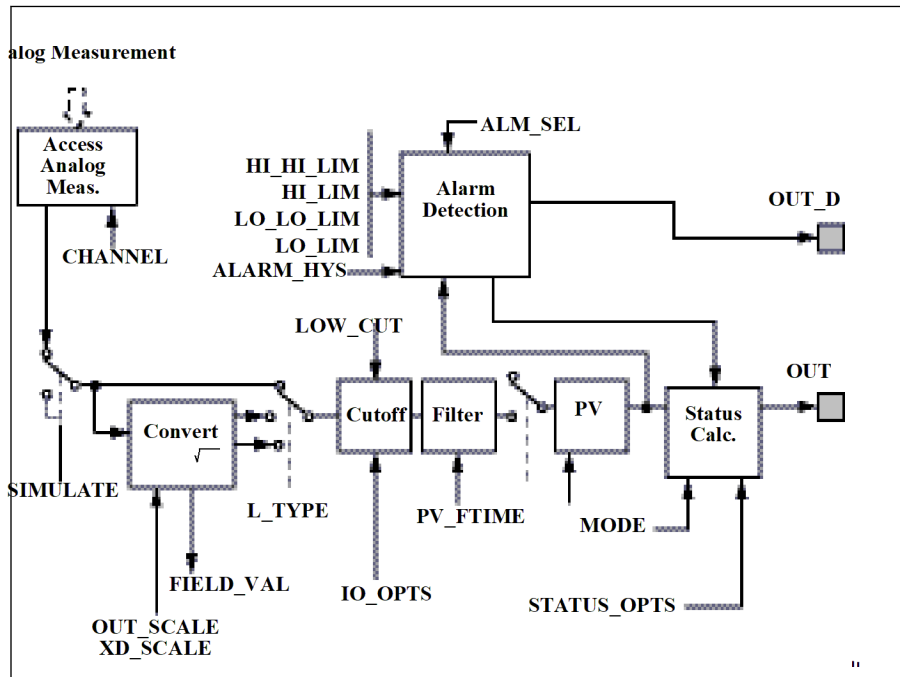

Figure D-2: Analog Input function block schematic



OUT = Block output value and status

OUT_D = Discrete output that signals a selected alarm condition

Filtering

The filtering feature changes the response time of the device to smooth variations in output readings caused by rapid changes in input. Adjust the filter time constant (in seconds) using the PV_FTIME parameter. Set the filter time constant to zero to disable the filter feature.

Signal conversion

Set the signal conversion type with the Linearization Type (L_TYPE) parameter. View the converted signal (in percent of XD_SCALE) through the FIELD_VAL parameter.

$$\text{FIELD_VAL} = \frac{100 \cdot (\text{Channel Value} - \text{EU}^* @ 0\%)}{(\text{EU}^* @ 100\% - \text{EU}^* @ 0\%)} \quad * \text{XD_SCALE values}$$

Choose from direct, indirect, or indirect square root signal conversion with the L_TYPE parameter.

Direct

Direct signal conversion allows the signal to pass through the accessed channel input value (or the simulated value when simulation is enabled).

PV = Channel Value

Indirect

Indirect signal conversion converts the signal linearly to the accessed channel input value (or the simulated value when simulation is enabled) from its specified range (XD_SCALE) to the range and units of the PV and OUT parameters (OUT_SCALE).

$$PV = \left(\frac{FIELD_VAL}{100} \right) \forall (EU^{**}@100\% - EU^{**}@0\%) + EU^{**}@0\%$$

** OUT_SCALE values

Indirect square root

Indirect Square Root signal conversion takes the square root of the value computed with the indirect signal conversion and scales it to the range and units of the PV and OUT parameters.

$$PV = \sqrt{\left(\frac{FIELD_VAL}{100} \right) \forall (EU^{**}@100\% - EU^{**}@0\%) + EU^{**}@0\%}$$

** OUT_SCALE values

When the converted input value is below the limit specified by the LOW_CUT parameter, and the Low Cutoff I/O option (IO_OPTS) is enabled (True), a value of zero is used for the converted value (PV). This option eliminates false readings when the differential pressure measurement is close to zero and it may be useful with zero-based measurement devices such as flowmeters.

Note

Low Cutoff is the only I/O option supported by the AI block. Set the I/O option when the block is OOS.

Block errors

Table D-2 lists conditions reported in the BLOCK_ERR parameter. Conditions in bold are inactive for the AI block and are given here for reference.

Table D-2: BLOCK_ERR conditions

Number	Name and description
0	Other
1	Block Configuration Error: the selected channel carries a measurement that is incompatible with the engineering units selected in XD_SCALE, the L_TYPE parameter is not configured, or CHANNEL = zero.
2	Link Configuration Error
3	Simulate Active: Simulation is enabled and the block is using a simulated value in its execution.
4	Local Override
5	Device Fault State Set
6	Device Needs Maintenance Soon
7	Input Failure/Process Variable has Bad Status: The hardware is bad, or a bad status is being simulated.
8	Output Failure: The output is bad based primarily upon a bad input.
9	Memory Failure
10	Lost Static Data
11	Lost NV Data

Table D-2: BLOCK_ERR conditions (continued)

Number	Name and description
12	Readback Check Failed
13	Device Needs Maintenance Now
14	Power Up
15	Out of Service: The actual mode is out of service.

Modes

The AI Function Block supports three modes of operation as defined by the MODE_BLK parameter.

- Manual (Man)** The value of the block output (OUT) may be set manually
- Automatic (Auto)** OUT reflects the analog input measurement or the simulated value when simulation is enabled.
- Out of service (OOS)** The block is not processed. FIELD_VAL and PV are not updated and the OUT status is set to Bad: Out of Service. The BLOCK_ERR parameter shows Out of Service. In this mode, changes can be made to all configurable parameters.

Alarm detection

A block alarm will be generated whenever the BLOCK_ERR has an error bit set. The types of block error for the AI block are defined above.

Process alarm detection is based on the OUT value. Configure the alarm limits of the following standard alarms:

- High (HI_LIM)
- High high (HI_HI_LIM)
- Low (LO_LIM)
- Low low (LO_LO_LIM)

To avoid alarm chatter when the variable is oscillating around the alarm limit, an alarm hysteresis in percent of the PV span can be set using the ALARM_HYS parameter. The priority of each alarm is set in the following parameters:

- HI_PRI
- HI_HI_PRI
- LO_PRI
- LO_LO_PRI

Table D-3: Alarm priority levels

Number	Description
0	The priority of an alarm condition changes to 0 after the condition that caused the alarm is corrected.
1	An alarm condition with a priority of 1 is recognized by the system, but is not reported to the operator.

Table D-3: Alarm priority levels (continued)

Number	Description
2	An alarm condition with a priority of 2 is reported to the operator, but does not require operator attention (such as diagnostics and system alerts).
3-7	Alarm conditions of priority 3 to 7 are advisory alarms of increasing priority.
8-15	Alarm conditions of priority 8 to 15 are critical alarms of increasing priority.

Status handling

Normally, the status of the PV reflects the status of the measurement value, the operating condition of the I/O card, and any active alarm condition. In Auto mode, OUT reflects the value and status quality of the PV. In Man mode, the OUT status constant limit is set to indicate that the value is a constant and the OUT status is Good.

If the sensor limit exceeds the high or low range, PV status is set high or low and EU range status is set to Uncertain.

In the STATUS_OPTS parameter, select from the following options to control the status handling.

BAD if limited	Sets the OUT status quality to <i>Bad</i> when the value is higher or lower than the sensor limits.
Uncertain if limited	Sets the OUT status quality to <i>Uncertain</i> when the value is higher or lower than the sensor limits.
Uncertain if in manual mode	The status of the Output is set to <i>Uncertain</i> when the mode is set to Manual.

Note

1. The instrument must be in OOS mode to set the status option.
 2. The AI block only supports the BAD if Limited option, uncertain if limited, and uncertain if manual.
-

Advanced features

The AI function block provided with Rosemount™ fieldbus devices provides added capability through the addition of the following parameters:

ALARM_TYPE

Allows one or more of the process alarm conditions detected by the AI function block to be used in setting its OUT_D parameter.

OUT_D

Discrete output of the AI function block based on the detection of process alarm condition(s). This parameter may be linked to other function blocks that require a discrete input based on the detected alarm condition.

STD_DEV and CAP_STDDEV

Diagnostic parameters that can be used to determine the variability of the process.

Application information

The configuration of the AI function block and its associated output channels depends on the specific application. A typical configuration for the AI block involves the following parameters:

CHANNEL

The device supports more than one measurement, so verify that the selected channel contains the appropriate measurement or derived value. Refer to [Table 3-8](#) for a listing of available channels on the 848T.

L_TYPE

Select Direct when the measurement is in the desired engineering units for the block output. Select Indirect when converting the measured variable into another, for example, pressure into level or flow into energy.

SCALING

XD_SCALE provides the range and units of the measurement and OUT_SCALE provides the range and engineering units of the output. OUT_SCALE is only used when in indirect or indirect square root.

D.1.2 AI block troubleshooting

Symptom	Possible causes	Corrective action
Mode will not leave OOS	Target mode not set	Set target mode to something other than OOS.
	Configuration error	BLOCK_ERR will show the configuration error bit set. The following are parameters that must be set before the block is allowed out of OOS: <ul style="list-style-type: none"> CHANNEL must be set to a valid value and cannot be left at initial value of 0. XD_SCALE.UNITS_INDEX must match the units in the transducer block channel value. Setting the units in the AI block automatically sets them in the XD_BLOCK. L_TYPE must be set to Direct, Indirect, or Indirect Square Root and cannot be left at initial value of 0.
	Resource block	The actual mode of the Resource block is OOS. See Resource Block Diagnostics for corrective action.
	Schedule	Block is not scheduled and therefore cannot execute to go to Target Mode. Typically, BLOCK_ERR will show "Power-Up" for all blocks that are not scheduled. Schedule the block to execute.
Process and/or block alarms will not work.	Features	FEATURES_SEL does not have Alerts enabled. Enable the Alerts bit.
	Notification	LIM_NOTIFY is not high enough. Set equal to MAX_NOTIFY. Alarm not linked to host.
	Status Options	STATUS_OPTS has Propagate Fault Forward bit set. This should be cleared to cause an alarm to occur.

Symptom	Possible causes	Corrective action
Value of output does not make sense	Linearization Type	L_TYPE must be set to Direct, Indirect, or Indirect Square Root and cannot be left at initial value of 0.
	Scaling	Scaling parameters are set incorrectly: <ul style="list-style-type: none"> • XD_SCALE.EU0 and EU100 should match that of the transducer block channel value. • OUT_SCALE.EU0 and EU100 are not set properly. • Both STB on each ASIC used must be in auto.
Cannot set HI_LIMIT, HI_HI_LIMIT, LO_LIMIT, or LO_LO_LIMIT Values	Scaling	Limit values are outside the OUT_SCALE.EU0 and OUT_SCALE.EU100 values. Change OUT_SCALE or set values within range.

D.2 Multiple analog input (MAI) function block

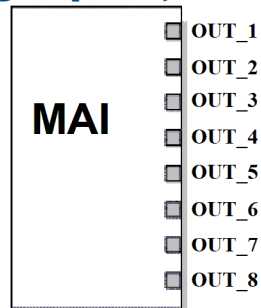

Out1 = The block output value and status for the first channel.

The MAI function block has the ability to process up to eight field device measurements and make them available to other function blocks. The output values from the MAI block are in engineering units and contain a status indicating the quality of the measurement. The measuring device may have several measurements or derived values available in different channels. Use the channel numbers to define the variables that the MAI block processes.

The MAI block supports signal scaling, signal filtering, signal status calculation, mode control, and simulation. In Automatic mode, the block's output parameters (OUT_1 to OUT_8) reflects the process variable (PV) values and status. In Manual mode, OUT may be set manually. The Manual mode is reflected on the output status. [Table D-4](#) lists the MAI block parameters and their units of measure, descriptions, and index numbers. The block execution time is 30 ms.

Table D-4: Multiple Analog Input function block parameters

Number	Parameter	Units	Description
1	ST_REV	None	The revision level of the static data associated with the input selector block. The revision value will be incremented each time a static parameter value in the block is changed.
2	TAG_DESC	None	The user description of the intended application of the block.

Table D-4: Multiple Analog Input function block parameters (continued)

Number	Parameter	Units	Description
3	STRATEGY	None	The strategy field can be used to identify grouping of blocks. This data is not checked or processed by the block.
4	ALERT_KEY	None	The identification number of the plant unit. This information may be used in the host for sorting alarms, etc.
5	MODE_BLK	None	The actual, target, permitted, and normal modes of the block. Actual: The mode the “block is currently in” Target: The mode to “go to” Permitted: Allowed modes that target may take on Normal: Most common mode for target
6	BLOCK_ERR	None	This parameter reflects the error status associated with the hardware or software components associated with a block. It is a bit string, so that multiple errors may be shown.
7	CHANNEL	None	Allows for custom channel setting. Valid values include: 0: Uninitialized 1: Channels 1 to 8 (index values 27 to 34 can only be set to their corresponding channel number, i.e. CHANNEL_X=X) 2: Custom settings (index values 27 to 34 can be configured for any valid channel as defined by the DD)
8, 9, 10, 11, 12, 13, 14, 15	OUT (1, 2, 3, 4, 5, 6, 7, 8)	EU of OUT_SCALE	The block output value and status
16	UPDATE_EVT	None	This alert is generated by any change to the static data
17	BLOCK_ALM	None	The block alarm is used for all configuration, hardware connection feature, or system problems in the block. The cause of the alert is entered in the subcode field. The first alert to become active will set the Active status in the Status parameter. As soon as the Unreported status is cleared by the alert reporting task, another block may be reported without clearing the Active status, if the subcode has changed.
18	SIMULATE	None	A group of data that contains the current sensor transducer value and status, and the enable/disable bit.

Table D-4: Multiple Analog Input function block parameters (continued)

Number	Parameter	Units	Description
19	XD_SCALE	None	The high and low scale values, engineering units code and number of digits to the right of the decimal point associated with the channel input value. The XD_SCALE units code must match the units code of the measurement channel in the transducer block. If the units do not match, the block will not transition to MAN or AUTO. It will automatically change units in the STB block to the last one written. Multiple blocks reading the same channel may conflict (only one unit type per channel).
20	OUT_SCALE	None	The high and low scale values, engineering unit code and number of digits to the right of the decimal point associated with OUT.
21	GRANT_DENY	None	Options for controlling access of host computers and local control panels for operating, tuning, and alarm parameters of the block. Not used by device.
22	IO_OPTS	None	Allows the selection of input/output options used to alter the PV. Low cutoff enabled is the only selectable option.
23	STATUS_OPTS	None	Allows the user to select options for status handling and processing. The options supported in the MAI block are the following: <ul style="list-style-type: none"> • Propagate fault forward • Uncertain if limited • Bad if limited • Uncertain if manual mode
24	L_TYPE	None	Linearization type. Determines whether the field value is uses directly (Direct), is converted linearly (Indirect), or is converted with the square root (Indirect Square Root)
25	LOW_CUT	%	If percentage value of the sensor transducer input falls below this, PV = 0
26	PV_FTIME	Seconds	The time constant of the first-order PV filter. It is the time required for a 63% change in the IN value.
27, 28, 29, 30, 31, 32, 33, 34	CHANNEL_(1, 2, 3, 4, 5, 6, 7, 8)	None	The CHANNEL (1, 2, 3, 4, 5, 6, 7, 8) value is used to select the measurement value. See Table D-4 for available channels. Configure the CHANNEL parameters to custom (2) before configuring the CHANNEL parameters.
35, 36, 37, 38, 39, 40, 41, 42	STDDEV_(1, 2, 3, 4, 5, 6, 7, 8)	% of OUT Range	Standard deviation of the corresponding measurement.
43, 44, 45, 46, 47, 48, 49, 50	CAP_STDDEV_(1, 2, 3, 4, 5, 6, 7, 8)	% of OUT Range	Capability standard deviation, the best deviation that can be achieved.

D.2.1 Functionality

Simulation

To support testing, either change the mode of the block to manual and adjust the output value or enable simulation through the configuration tool and manually enter a value for the measurement value and its status (this single value will apply to all outputs). In both cases, first set the ENABLE jumper on the field device.

Note

All FOUNDATION™ Fieldbus instruments have a simulation jumper. As a safety measure, the jumper has to be reset every time there is a power interruption. This measure is to prevent devices that went through simulation in the staging process from being installed with simulation enabled.

With simulation enabled, the actual measurement value has no impact on the OUT value or the status. The OUT values will all have the same value as determined by the simulate value.

Figure D-3: Multiple Analog Input function block timing diagram

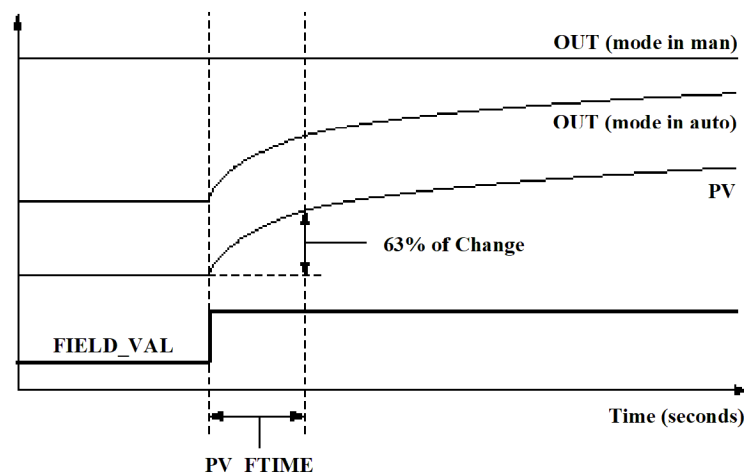
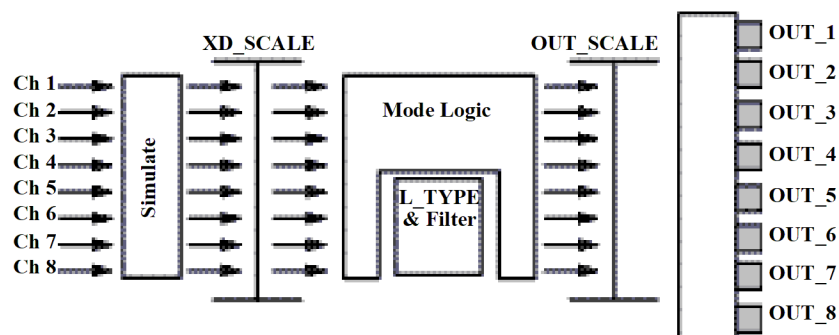

Figure D-4: Multiple Analog Input function block schematic



Filtering

The filtering feature changes the response time of the device to smooth variations in output readings caused by rapid changes in input. Adjust the filter time constant (in seconds) using the PV_FTIME parameter (same value applied to eight channels). Set the filter time constant to zero to disable the filter feature.

Signal conversion

Set the signal conversion type with the Linearization Type (L_TYPE) parameter. Choose from direct, indirect, or indirect square root signal conversion with the L_TYPE parameter.

Direct

Direct signal conversion allows the signal to pass through the accessed channel input value (or the simulated value when simulation is enabled).

PV = Channel Value

Indirect

Indirect signal conversion converts the signal linearly to the accessed channel input value (or the simulated value when simulation is enabled) from its specified range (XD_SCALE) to the range and units of the PV and OUT parameters (OUT_SCALE).

$$PV = \left(\frac{\text{Channel Value}}{100} \right) \text{¥} (EU^{**}@100\% - EU^{**}@0\%) + EU^{**}@0\%$$

** OUT_SCALE values

Indirect square root

Indirect Square Root signal conversion takes the square root of the value computed with the indirect signal conversion and scales it to the range and units of the PV and OUT parameters.

$$PV = \sqrt{\left(\frac{\text{Channel Value}}{100} \right)} \text{¥} (EU^{**}@100\% - EU^{**}@0\%) + EU^{**}@0\%$$

** OUT_SCALE values

When the converted input value is below the limit specified by the LOW_CUT parameter, and the Low Cutoff I/O option (IO_OPT5) is enabled (True), a value of zero is used for the converted value (PV). This option is useful to eliminate false readings when the differential temperature measurement is close to zero, and it may also be useful with zero-based measurement devices such as flow meters.

Note

Low Cutoff is the only I/O option supported by the MAI block. Set the I/O option in Manual or Out of Service mode only.

Block errors

Table D-5 lists conditions reported in the BLOCK_ERR parameter. Conditions in bold are inactive for the MAI block and are given for reference.

Table D-5: BLOCK_ERR Conditions

Number	Name and description
0	Other
1	Block Configuration Error: the selected channel carries a measurement that is incompatible with the engineering units selected in XD_SCALE, the L_TYPE parameter is not configured, or WRITE_CHECK = zero.
2	Link Configuration Error

Table D-5: BLOCK_ERR Conditions (continued)

Number	Name and description
3	Simulate Active: Simulation is enabled and the block is using a simulated value in its execution.
4	Local Override
5	Device Fault State Set
6	Device Needs Maintenance Soon
7	Input Failure/Process Variable has Bad Status: The hardware is bad, or a bad status is being simulated.
8	Output Failure: The output is bad based primarily upon a bad input.
9	Memory Failure
10	Lost Static Data
11	Lost NV Data
12	Readback Check Failed
13	Device Needs Maintenance Now
14	Power Up
15	Out of Service: The actual mode is out of service.

Modes

The MAI Function Block supports three modes of operation as defined by the MODE_BLK parameter.

- Manual (Man)** The block output (OUT) may be set manually.
- Automatic (Auto)** OUT_1 to OUT_8 reflects the analog input measurement or the simulated value when simulation is enabled.
- Out of Service (OOS)** The block is not processed. PV is not updated and the OUT status is set to Bad: Out of Service. The BLOCK_ERR parameter shows Out of Service. In this mode, changes can be made to all configurable parameters. The target mode of a block may be restricted to one or more of the supported modes.

Status handling

Normally, the status of the PV reflects the status of the measurement value, the operating condition of the I/O card, and any active alarm condition. In Auto mode, OUT reflects the value and status quality of the PV. In Man mode, the OUT status constant limit is set to indicate that the value is a constant and the OUT status is Good.

If the sensor limit exceeds the high or low side range, PV status is set high or low and EU range status is set to uncertain.

In the STATUS_OPTS parameter, select from the following options to control the status handling.

- BAD if limited** Sets the OUT status quality to “Bad” when the value is higher or lower than the sensor limits.
- Uncertain if limited** Sets the OUT status quality to “Uncertain” when the value is higher or lower than the sensor limits.

Uncertain if in manual mode The status of the Output is set to “Uncertain” when the mode is set to Manual.

Note

1. The instrument must be OOS to set the status option.
2. The MAI block only supports the BAD if Limited option.

Application information

The intended use for this type of function block is for applications where the sensor types and functionality of each channel (i.e. the simulate, scaling, filtering, alarms type, and options) are the same.

The configuration of the MAI function block and its associated output channels depends on the specific application. A typical configuration for the MAI block involves the following parameters:

CHANNEL

If the device supports more than one measurement, verify that the selected channel contains the appropriate measurement or derived value. Refer to [Table D-4](#) for a listing of available channels on the 848T.

L_TYPE

Select Direct when the measurement is already in the desired engineering units for the block output. Select Indirect when converting the measured variable into another, for example, pressure into level or flow into energy. Select Indirect Square Root when the block I/O parameter value represents a flow measurement made using differential pressure, and when square root extraction is not performed by the transducer.

SCALING

XD_SCALE provides the range and units of the measurement and OUT_SCALE provides the range and engineering units of the output.

D.2.2 MAI block troubleshooting

Symptom	Possible causes	Corrective action
Mode will not leave OOS	Target mode not set	Set target mode to something other than OOS.
	Configuration error	BLOCK_ERR will show the configuration error bit set. The following are parameters that must be set before the block is allowed out of OOS: <ul style="list-style-type: none"> • Initial value is 1. • XD_SCALE. UNITS_INDEX must match the units in all the corresponding sensor transducer blocks. • L_TYPE must be set to Direct, Indirect, or Indirect Square Root and cannot be left at initial value of 0.
	Resource block	The actual mode of the Resource block is OOS. See Resource Block Diagnostics for corrective action.
	Schedule	Block is not scheduled and therefore cannot execute to go to Target Mode. Typically, BLOCK_ERR will show “Power-Up” for all blocks that are not scheduled. Schedule the block to execute.

Symptom	Possible causes	Corrective action
Process and/or block alarms will not work.	Features	FEATURES_SEL does not have Alerts enabled. Enable the Alerts bit.
	Notification	LIM_NOTIFY is not high enough. Set equal to MAX_NOTIFY.
	Status Options	STATUS_OPTS has Propagate Fault Forward bit set. This should be cleared to cause an alarm to occur.
Value of output does not make sense	Linearization Type	L_TYPE must be set to Direct, Indirect, or Indirect Square Root and cannot be left at initial value of 0.
	Scaling	Scaling parameters are set incorrectly: <ul style="list-style-type: none"> • XD_SCALE.EU0 and EU100 should match that of the corresponding sensor transducer block. • OUT_SCALE.EU0 and EU100 are not set properly. • Both STBs in an ASIC must be set to auto. Best in 1, 2, 7, 8, ASICs in Auto for thermocouples

D.3 Input selector function block

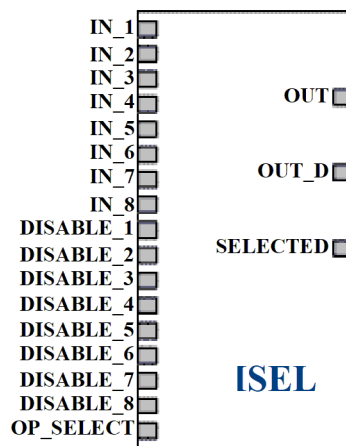

IN (1-8) = Input

DISABLE (1-8) = Discrete input used to disable the associated input channel

SELECTED = The selected channel number

OUT = The block output and status

OUT_D = Discrete output that signals a selected alarm condition

The Input Selector (ISEL) function block can be used to select the first good, Hot Backup™, maximum, minimum, or average of as many as eight input values and place it at the output. The block supports signal status propagation. There is process alarm detection in the Input Selector function block. [Table D-6](#) lists the ISEL block parameters and their descriptions, units of measure, and index numbers. The block execution time is 30 ms.

Table D-6: Input Selector function block parameters

Number	Parameter	Units	Description
1	ST_REV	None	The revision level of the static data associated with the input selector block. The revision value will be incremented each time a static parameter value in the block is changed.
2	TAG_DESC	None	The user description of the intended application of the block.
3	STRATEGY	None	The strategy field can be used to identify groupings of blocks. This data is not checked or processed by the block.
4	ALERT_KEY	None	The identification number of the plant unit. This information may be used in the host for sorting alarms, etc.
5	MODE_BLK	None	The actual, target, permitted, and normal modes of the block. Actual: The mode the block is currently in Target: The mode to “go to” Permitted: Allowed modes that target may take on Normal: Most common mode for target
6	BLOCK_ERR	None	This parameter reflects the error status associated with the hardware or software components associated with a block. It is a bit string, so that multiple errors may be shown.
7	OUT	OUT_RANGE	The primary analog value calculated as a result of executing the function block.
8	OUT_RANGE	EU of OUT	The engineering units code to be used in displaying the OUT parameter and parameters which have the same scaling as OUT.
9	GRANT_DENY	None	Options for controlling access of host computers and local control panels to operating, tuning, and alarm parameters of the block. Not used by device.
10	STATUS_OPTS	None	Allows the user to select options for status handling and processing.
11, 12, 13, 14, 25, 26, 27, 28	IN_(1, 2, 3, 4, 5, 6, 7, 8)	Determined by source	A connection input from another block
15, 16, 17, 18, 29, 30, 31, 32	DISABLE_(1, 2, 3, 4, 5, 6, 7, 8)	None	A connection from another block that disables the associated input from the selection.
19	SELECT_TYPE	None	Specifies input selection method. Methods available include: First Good, Minimum, Maximum, Middle, Average, or Hot Backup.
20	MIN_GOOD	None	The minimum number of good inputs.
21	SELECTED	None	The selected input number (1 to 8) or the number of input used for the average output.

Table D-6: Input Selector function block parameters (continued)

Number	Parameter	Units	Description
22	OP_SELECT	None	Overrides the algorithm to select 1 of the 8 inputs regardless of the selection type.
23	UPDATE_EVT	None	This alert is generated by any change to the static data
24	BLOCK_ALM	None	The block alarm is used for all configuration, hardware, connection failure, or system problems in the block. The cause of the alert is entered in the subcode field. The first alert to become active will set the Active status in the Status parameter. As soon as the Unreported status is cleared by the alert reporting task, another block may be reported without clearing the Active status, if the subcode has changed.
33	AVG_USE	None	Number of parameters to use in the averaging calculation. For example, if AVG_USE is 4 and the number of connected inputs is 6, then the highest and lowest values would be dropped prior to calculating the average. If AVG_USE is 2 and the number of connected inputs is 7, then the two highest and lowest values would be dropped prior to calculating the average and the average would be based on the middle three inputs.
34	ALARM_SUM	None	The current alert status, unacknowledged states, and disabled states of the alarms associated with the function block.
35	ACK_OPTION	None	Used to set automatic acknowledgment of alarms.
36	ALARM_HYS	Percent	The amount the alarm value must return within the alarm limit before the associated active alarm condition clears
37	HI_HI-PRI	None	The priority of the HI HI alarm
38	HI_HI_LIM	Percent	The setting for the alarm limit used to detect the HI HI alarm condition.
39	HI_PRI	None	The priority of the HI alarm
40	HI_LIM	EU of IN	The setting for the alarm limit used to detect the HI alarm condition
41	LO_PRI	None	The priority of the LO alarm
42	LO_LIM	EU of IN	The setting of the alarm limit used to detect the LO alarm condition
43	LO_LO-PRI	None	The priority of the LO LO alarm
44	LO_LO_LIM	EU of IN	The setting for the alarm limit sued to detect the LO LO alarm condition
45	HI_HI_ALM	None	The HI HI alarm data, which includes a value of the alarm, a timestamp of occurrence and the state of the alarm
46	HI_ALM	None	The HI alarm data, which includes a value of the alarm, a timestamp of occurrence and the state of the alarm

Table D-6: Input Selector function block parameters (continued)

Number	Parameter	Units	Description
47	LO_ALM	None	The LO alarm data, which includes a value of the alarm, a timestamp of occurrence and the state of the alarm
48	LO_LO_ALM	None	The LO LO alarm data, which includes a value of the alarm, a timestamp of occurrence and the state of the alarm
49	OUT_D	None	Discrete output to indicate a selected alarm value
50	ALM_SEL	None	Used to select the process alarm conditions that will cause the OUT_D parameter to be set.

D.3.1 Functionality

Figure D-5: Input Selector function block schematic

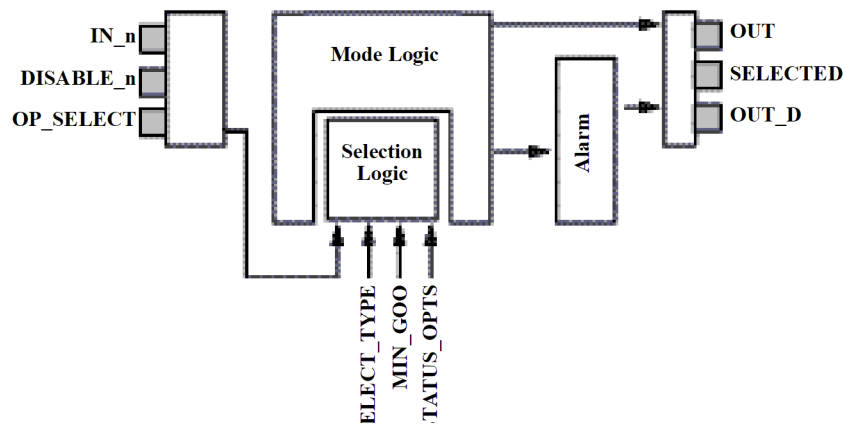

Block errors

Table D-7 lists conditions reported in the BLOCK_ERR parameter. Conditions in bold are inactive for the ISEL block and are given for reference.

Table D-7: BLOCK_ERR conditions

Number	Name and description
0	Other: The output has a quality of uncertain.
1	Block Configuration Error: Select type is not configured
2	Link Configuration Error
3	Simulate Active
4	Local Override
5	Device Fault State Set
6	Device Needs Maintenance Soon
7	Input Failure/Process Variable has Bad Status: One of the inputs is Bad.
8	Output Failure

Table D-7: BLOCK_ERR conditions (continued)

Number	Name and description
9	Memory Failure
10	Lost Static Data
11	Lost NV Data
12	Readback Check Failed
13	Device Needs Maintenance Now
14	Power Up: The device was just powered-up.
15	Out of Service: The actual mode is out of service.

Modes

The ISEL function block supports three modes of operation as defined by the MODE_BLK parameter:

- Manual (Man)** The block output (OUT) may be set manually.
- Automatic (Auto)** OUT reflects the selected value.
- Out of Service (OOS)** The block is not processed. The BLOCK_ERR parameter shows Out of Service. The target mode of a block may be restricted to one or more of the supported modes. In this mode, changes can be made to all configurable parameters.

Alarm detection

A block alarm will be generated whenever the BLOCK_ERR has an error bit set. The type of block errors for the ISEL block are defined above.

Process Alarm detection is based on the OUT value. The alarm limits of the following standard alarms can be configured.

- High (HI_LIM)
- High high (HI_HI_LIM)
- Lo (LO_LIM)
- Lo low (LO_LO_LIM)

In order to avoid alarm chattering when the variable is oscillating around the alarm limit, an alarm hysteresis in percent of the PV span can be set using the ALARM_HYS parameter. The priority of each alarm is set in the following parameters:

- HI_PRI
- HI_HI_PRI
- LO_PRI
- LO_LO_PRI

Table D-8: Alarm Priority Levels

Number	Description
0	The priority of an alarm condition changes to 0 after the condition that caused the alarm is corrected.

Table D-8: Alarm Priority Levels (continued)

Number	Description
1	An alarm condition with a priority of 1 is recognized by the system, but is not reported to the operator.
2	An alarm condition with a priority of 2 is reported to the operator, but does not require operator attention (such as diagnostics and system alerts).
3-7	Alarm conditions of priority 3 to 7 are advisory alarms of increasing priority.
8-15	Alarm conditions of priority 8 to 15 are critical alarms of increasing priority.

Block execution

The ISEL function block reads the values and status of up to eight inputs. To specify which of the six available methods (algorithms) is used to select the output, configure the selector type parameter (SELECT_TYPE) as follows:

- Max selects the maximum value of the inputs.
- Min selects the minimum value of the inputs.
- Avg calculates the average value of the inputs.
- Mid calculates the update for eight sensors.
- 1st Good selects the first available good input.

If the DISABLE_N is active, the associated input is not used in the selection algorithm.

If an input is not connected, it is also not used in the algorithm.

If the OP_SELECT is set to a value between 1 and 8, the selection type logic is overridden and the output value and status is set to the value and status of the input selected by OP_SELECT.

SELECTED will have the number of selected input unless the SELECT_TYPE is mid, in which case it will take the average of the two middle values. Then SELECTED will be set to "0" if there is an even number of inputs.

Status handling

In Auto mode, OUT reflects the value and status quality of the selected input. If the number of inputs with Good status is less than MIN_GOOD, the output status will be Bad.

In Man mode, the OUT status high and low limits are set to indicate that the value is a constant and the OUT status is always Good.

In the STATUS_OPTS parameter, select from the following options to control the status handling:

Use uncertain as good Sets the OUT status quality to Good when the selected input status is Uncertain.

Uncertain if in manual mode The status of the Output is set to Uncertain when the mode is set to manual.

Note

The instrument must be to OOS to set the status option.

Application information

Use the ISEL function block to:

- Select the maximum temperature input from eight inputs and send it to another function block (see Figure D-6)
- Calculate the average temperature of the eight inputs (see Figure D-7)
- Use only six of the eight inputs to calculate the average temperature.

Figure D-6: Input Selector function block application example (SEL_TYPE = max)

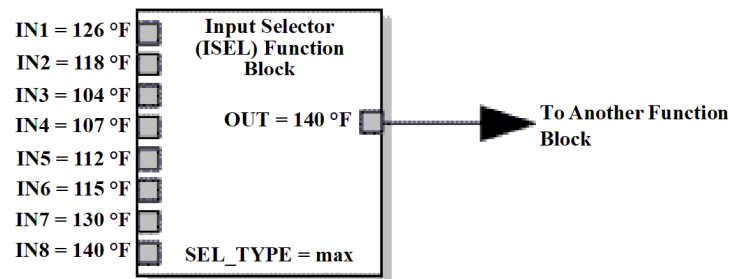
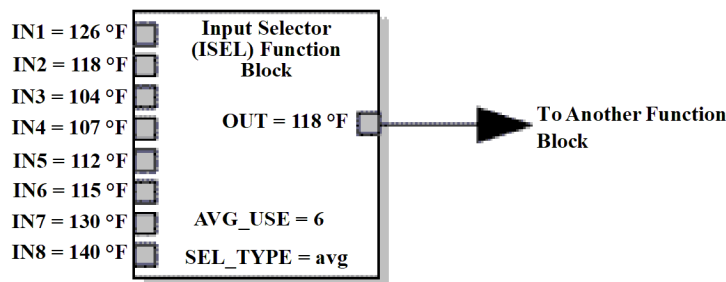

Figure D-7: Input Selector function block application example (SEL_TYPE = average) AVG_USE = 6



$$\frac{107 + 112 + 115 + 118 + 126 + 130}{6} = 118^{\circ}\text{F}$$

To determine OUT for a 6-input reading, read all eight, sort in numerical order, drop the highest and lowest values, and calculate the average.

D.3.2 ISEL block troubleshooting

Symptom	Possible causes	Corrective action
Mode will not leave OOS	Target mode not set	Set target mode to something other than OOS.
	Configuration error	BLOCK_ERR will show the configuration error bit set. SELECT_TYPE must be set to a valid value and cannot be left at 0.
	Resource block	The actual mode of the Resource block is OOS. See Resource Block Diagnostics for corrective action.
	Schedule	Block is not scheduled and therefore cannot execute to go to Target Mode. Typically, BLOCK_ERR will show "Power-Up" for all blocks that are not scheduled. Schedule the block to execute.
Status of output is BAD	Inputs	All inputs have Bad status

Symptom	Possible causes	Corrective action
	OP selected	OP_SELECT is not set to 0 (or it is linked to an input that is not 0), and it points to an input that is Bad.
	Min good	The number of Good inputs is less than MIN_GOOD.
	Block is in OOS mode	Change mode to Auto
Block alarms will not work	Features	FEATURES_SEL in the resource block does not have Alerts enabled. Enable the Alerts bit.
	Notification	LIM_NOTIFY in the resource block is not high enough. Set equal to MAX_NOTIFY.
	Status Options	STATUS_OPTS has Propagate Fault Forward bit set. This should be cleared to cause an alarm to occur.
Cannot set HI_LIMIT, HI_HI_LIMIT, LO_LIMIT, LO_LO_LIMIT	Scaling	Limit values are outside the OUT_SCALE.EU0 and OUT_SCALE.EU100 values. Change OUT_SCALE or set values within range.

For more information: www.emerson.com

©2022 Emerson. All rights reserved.

Emerson Terms and Conditions of Sale are available upon request. The Emerson logo is a trademark and service mark of Emerson Electric Co. Rosemount is a mark of one of the Emerson family of companies. All other marks are the property of their respective owners.

ROSEMOUNT™

