

# Rosemount™ 2501 Solids Level Switch

## Rotating Paddle



CE

- Universal voltage electronics
- Rotation principle is unaffected by caking
- Protected motor (friction clutch and double bearing)
- Modular design
- Temperature range from -40 to 2012 °F (-40 to 1100 °C)

# Introduction

## Measurement principles

The Rosemount™ 2501 Solids Level Switch uses a synchronous motor for driving a paddle (measuring vane) to rotate 360 degrees.

When the vane of the paddle is not covered by a solids medium, a spring pulls the motor and it switches a lug to the left position (Figure 1, left illustration). The signal output indicates an 'uncovered' state and the motor rotates the paddle.

When a solids medium covers the vane of the paddle, and causes the rotation to stop, the lug is switched to the right position (Figure 1, right illustration). The signal output indicates a 'covered' state due to a rising level of material, and the motor is stopped until the vane becomes uncovered.

**Figure 1: Switching Lug Function**

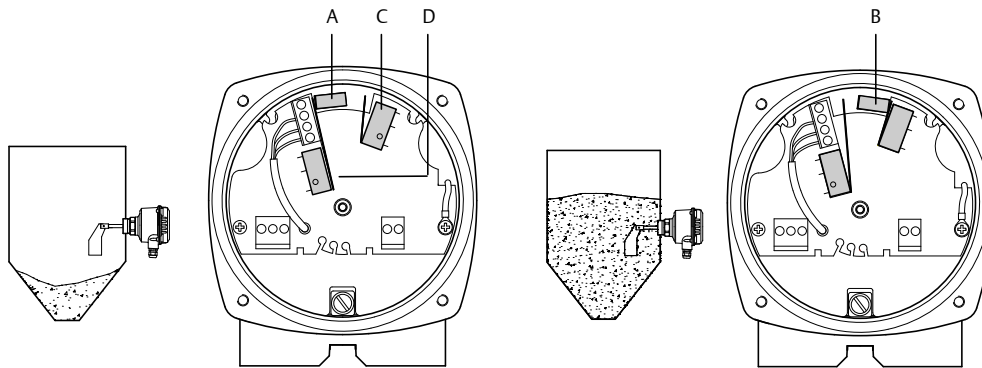

- A. Switching lug in left position ('uncovered' state)
- B. Switching lug in right position ('covered' state)
- C. Switch for stopping the motor
- D. Switch for signal output

The electrical outputs vary depending on the power supply selected when the Rosemount 2501 was ordered. See [Ordering information](#) for the Power Supply option codes, and [Electrical data](#) for the electrical specifications.

## Contents

Introduction.....	2
Ordering information.....	5
Spares and accessories.....	10
Specifications.....	14
Product certifications.....	20
Dimensional drawings.....	21

## Key features and benefits

- Ideal for point level detection of most bulk solids materials
- Simple to install, maintenance-free measurement principle
- Reliable technology, unaffected by dust, electrostatic charge and clogging/caking
- Robust NEMA® Type 4X housing<sup>(1)</sup>, which is suitable for use in extreme process conditions
- Designed for operation in temperature extremes of -40 °F to 2012 °F (-40 °C to 1100 °C)
- Different models to suit different sizes/types of process vessels and storage silos
- Generous space within housing with rotatable electronics, enabling easy wiring for quick installation
- Encapsulated ball bearing with shaft sealing, ideal for dusty applications
- Versatile installation in many types of vessel
  - It can be installed in vertical, horizontal, or angled positions with various extensions options available.
- Compact boom length from 2¾ in. (70 mm) is particularly suited for small process vessels

## Applications

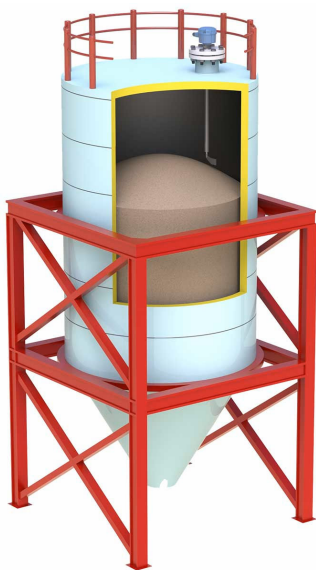

- Materials with most density types
- Silos/vessels with limited space or large storage silos
- Environments with high levels of dust/ash present
- Overfill prevention
- High-reliability and high-safety requirements
- High-temperature applications



(1) The NEMA Type 4X rating requires the process connection (including extension) to be stainless steel and the process temperature to not exceed 176 °F (80 °C). In all other cases, including when a sliding sleeve is used or a Rosemount 2501 with Application Profile K, the housing is IP66/NEMA Type 4 rated.

## Selection guide

Table 1: Rosemount 2501 Selection Guide

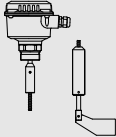
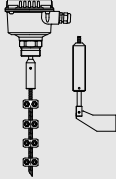
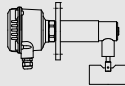
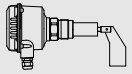
Type of installation	Model option codes					
	2501L	2501M	2501R	2501S	2501K	2501J
						
Full silo detection	*	*(1)	*	*	*	*
On-demand detection	*		*(1)	*(1)	*	*
Empty silo detection	*		*(1)	*(1)	*	*
Vertical mounting	*	*	*(1)	*(1)		*
Angled mounting (top)	*	*(2)				*
Horizontal mounting	*				*	*
Angled mounting (bottom)	*					*

(1) Consider the maximum permitted mechanical traction force. See [Operating conditions](#) for the maximum supported mechanical loads.

(2) Available only with the "bearing at tube end" option (maximum of 10°).

## Ordering information

**Table 2: Rosemount 2501 Ordering Information**

The starred offerings (★) represent the most common options and should be selected for best delivery. The non-starred offerings are subject to additional delivery lead time.

Model	Product description		
2501	Rosemount Solids Level Switch - Paddle		★
<b>Application profile</b>			
L	Full or empty detection in small vessel, low mechanical resistance		★
M	Full detection in medium vessel, medium mechanical resistance		★
R	Full detection in large vessel, medium mechanical resistance (maximum 4 kN load)		★
S	Full detection in large vessel, high mechanical resistance (maximum 28 kN load)		★
J	Empty detection in medium or large vessel, low or medium mechanical resistance		★
K <sup>(1)</sup>	Empty detection in medium or large vessel, high mechanical resistance		★
<b>Operating temperature</b>			<b>Applications</b>
1	Maximum 176 °F (80 °C)	All	★
2 <sup>(2)</sup>	Maximum 302 °F (150 °C)	All except S	★
3 <sup>(2)</sup>	Maximum 482 °F (250 °C)	All except S	★
4 <sup>(2)</sup>	Maximum 662 °F (350 °C)	L and J only	★
5 <sup>(3)(2)</sup>	Maximum 1112 °F (600 °C),	All except S and K	★
6 <sup>(2)</sup>	Maximum 2012 °F (1100 °C)	L and M only	★
<b>Process operating pressure</b>			<b>Temperatures</b>
A	Maximum 11.6 psi (0.8 bar)	All codes	★
B	Maximum 73 psi (5 bar)	1, 2, and 3	★
C	Maximum 145 psi (10 bar)	1, 2, and 3	★
<b>Materials of construction: process connection</b>			<b>Applications</b>
A <sup>(4)(5)</sup>	Aluminum	All except S	★
D <sup>(6)</sup>	303/304 Stainless steel (1.4301/1.4305)	All codes	★
S <sup>(6)</sup>	316L Stainless steel (1.4404)	L, M, and J	★
<b>Materials of construction: extension</b>		<b>Applications</b>	<b>Materials (PC)</b>
A <sup>(5)(7)(8)</sup>	Aluminum	M, J, and K	A and D
D <sup>(6)(9)</sup>	303/304 Stainless steel (1.4301/1.4305)	All codes	A and D
F <sup>(6)</sup>	316L Stainless steel (1.4404)	L, J and M	S
<b>Conduit entry/cable threads</b>			
1	M20 x 1.5, 1 off screwed cable gland for CE, ATEX, and IECEx		★
2	M20 x 1.5, 2 off screwed cable gland		
4	½-in. NPT tapered, ANSI B1.20.1 (1 off conduit + 1 off Ex-d blind plug)		

**Table 2: Rosemount 2501 Ordering Information (continued)**

Process connection size		Applications	Temperatures	
1 <sup>(10)(11)</sup>	1-in. / 25 mm (DN25) / 25A	L	1, 2, 3	★
A <sup>(10)</sup>	1¼-in. / 32 mm (DN32) / 32A	All except K	1, 2, 3	★
5	1½-in. / 40 mm (DN40) / 40A	All except K	All	★
2 <sup>(12)</sup>	2-in. / 50 mm (DN50) / 50A	All except K	All	★
3 <sup>(12)</sup>	3-in. / 80 mm (DN80) / 80A	All except K	All	★
4	4-in. / 100 mm (DN100) / 100A	All	All	★
B <sup>(5)(10)(11)</sup>	M30 x 1.5 mm	L only	1 only	★
C <sup>(5)(10)(11)</sup>	M32 x 1.5 mm	L only	1, 2, 3	★
Process connection rating		Sizes	Materials (PC)	
AA	ASME B16.5 Class 150 flange	2, 3, and 4	All except A	★
DZ <sup>(13)</sup>	EN1092-1 PN6 flange	A and 4	All <sup>(14)</sup>	★
DA	EN1092-1 PN16 flange	2 and 4	All except A	★
HA <sup>(5)</sup>	150x150 flange, 4 off ø18 mm fixing holes	4	All except S	★
HB <sup>(5)</sup>	150x150 flange, 4 off ø14 mm fixing holes	4	All except S	★
NN	For use with non-flange process connections	All except 3 and 4	All	★
Process connection type		Ratings	Applications	
F	Flat face flange	DZ, DA, HA, and HB	All	★
R	Raised face flange	AA	All	★
G	BSPP (G) thread	NN	All except K	★
N	NPT thread	NN	All except K	★
M <sup>(5)(15)</sup>	Metric thread	NN	L	★
C <sup>(15)</sup>	Tri Clamp	NN	L, M, and J	★
Power supply				
A	230 Vac 50-60 Hz, motor speed: 1 revolution per minute			
B	115 Vac 50-60 Hz, motor speed: 1 revolution per minute			
C	48 Vac 50-60 Hz, motor speed: 1 revolution per minute			
D	24 Vac 50-60 Hz, motor speed: 1 revolution per minute			
E	24 Vdc, motor speed: 1 revolution per minute			
F	24 Vdc / 22 to 230 Vac universal voltage, motor speed: 1 revolution per minute			★
R	230 Vac 50-60 Hz, motor speed: 5 revolutions per minute			
S	115 Vac 50-60 Hz, motor speed: 5 revolutions per minute			
T	48 Vac 50-60 Hz, motor speed: 5 revolutions per minute			
U	24 Vac 50-60 Hz, motor speed: 5 revolutions per minute			
V	24 Vdc, motor speed: 5 revolutions per minute			
W	24 Vdc / 22 to 230 Vac universal voltage, motor speed: 5 revolutions per minute			★

**Table 2: Rosemount 2501 Ordering Information (continued)**

<b>Paddle length</b>		<b>Applications</b>		
A <sup>(16)</sup>	Standard length 2.76-in. (70 mm)	L	★	
B <sup>(16)</sup>	Standard length 3.93-in. (100 mm)	L	★	
C <sup>(16)</sup>	Standard length 4.92-in. (125 mm)	K	★	
D <sup>(16)</sup>	Standard length 5.90-in. (150 mm)	L, J, and K	★	
G	Standard length 7.87-in. (200 mm)	L, J, and K	★	
H	Standard length 9.84-in. (250 mm)	L, J, and K	★	
J	Standard length 11.8-in. (300 mm)	L, J, and K	★	
R	Rope fixings only (rope not included)	R	★	
E	Extended shaft/tube, customer specified length in tenths of inches	L, M, J, and K	★	
M	Extended shaft/tube, customer specified length in millimeters	L, M, J, and K	★	
F	Extended rope, customer specified length in tenths of inches	R and S	★	
N	Extended rope, customer specified length in millimeters	R and S	★	
<b>Specific extended length</b>				
00000	Factory default length (only if Paddle Length A, B, C, D, G, H, J, or R selected)		★	
XXXXX	Specific customer-specified length in tenths of inches or millimeters (XXXX.X inches or XXXXX mm)		★	
<b>Product certifications</b>		<b>Conduit entries</b>		
NA	No hazardous locations certifications	All codes	★	
ND <sup>(17)</sup>	ATEX Dust certification	All codes		
NK <sup>(17)</sup>	IECEX Dust certification	All codes		
NL <sup>(17)</sup>	American DIP	4		
E2 <sup>(17)</sup>	INMETRO Flameproof	4		
E5 <sup>(17)</sup>	American Flameproof/Dust certification	4		
E7 <sup>(17)</sup>	IECEX Flameproof/Dust certification	4		
E8 <sup>(17)</sup>	ATEX Flameproof/Dust certification	4		
EM <sup>(17)</sup>	Technical Regulations Customs Union (EAC), Dust certification	All codes		
K1 <sup>(17)</sup>	ATEX Flameproof/Increased Safety/Dust certification	All codes		
K7 <sup>(17)</sup>	IECEX Flameproof/Increased Safety/Dust certification	All codes		
KB <sup>(17)</sup>	American and Canadian DIP	4		
KM <sup>(17)</sup>	Safety/Dust certification	All codes		
KY <sup>(17)</sup>	American and Canadian Flameproof/Dust certification	4		
KZ <sup>(17)</sup>	American and Canadian Ordinary Location (Unclassified, safe area) certification	4		
<b>Measuring vane</b>		<b>Applications</b>	<b>Materials<sup>(18)</sup></b>	
A	1.02 x 3.03 inches (26 x 77 mm), boot-shaped vane	L	A and D	★
B	1.10 x 3.86 inches (28 x 98 mm), boot-shaped vane	L	All	★
C	1.38 x 4.17 inches (35 x 106 mm), boot-shaped vane	All except K	All	★

**Table 2: Rosemount 2501 Ordering Information (continued)**

D	1.57 x 3.86 inches (40 x 98 mm), boot-shaped vane	All	All	★
K	1.57 x 3.15 inches (40 x 80 mm), rectangular notched vane	L	D and F	★
L	1.97 x 3.86 inches (50 x 98 mm), rectangular vane	All	A and D	★
M	1.97 x 5.90 inches (50 x 150 mm), rectangular vane	All	A and D	★
N	1.97 x 9.84 inches (50 x 250 mm), rectangular vane	All	A and D	★
P	3.86 x 3.86 inches (98 x 98 mm), rectangular vane	All	All	★
Q	3.86 x 5.90 inches (98 x 150 mm), rectangular vane	All	A and D	★
R	3.86 x 9.84 inches (98 x 250 mm), rectangular vane	All	A and D	★
U <sup>(6)(19)</sup>	3.86 x 3.93 inches (98 x 100 mm), single-sided hinged vane	All	All	★
V <sup>(6)(19)</sup>	3.86 x 7.87 inches (98 x 200 mm), double-sided hinged vane	All	All	★
W <sup>(4)</sup>	3.86 x 9.84 inches (98 x 250 mm), rubber vane, up to 176 °F (80 °C)	All	A and D	★
Y	Split fin fixing for vane (vane not included)	All	A and D	★
<b>Options (include with selected model number)</b>				
<b>Calibration data certification</b>				
Q4	Certificate of functional test			★
<b>Alarm</b>				
AF <sup>(20)</sup>	Fail-safe alarm			★
<b>Weather protection</b>				
P2	Weather protection cover			★
<b>Welded flange <sup>(21)</sup></b>			<b>Paddle length</b>	
W1	Process connection flange welded to paddle tube		All except A and B	★
W2 <sup>(22)</sup>	Process connection flange welded to paddle tube, including reinforcing rib		All except A, B, C	★
<b>Specific welded flange angle</b>				
XX	Specific customer-specified angle of flange (0° to 45°) (maximum 30° with Welded Flange W2)			★
<b>Paddle extension<sup>(23)</sup></b>				
PE1	Pendulum extension, 7.87 in. (200 mm), vertical or horizontal installation			★
PE2	Pendulum extension, 19.7 in. (500 mm), vertical installation			★
PE3	Pendulum extension, 39.4 in. (1000 mm), vertical installation			★
PE4	Rope extension, 78.7 in. (2000 mm), vertical installation			★
<b>Sliding sleeve<sup>(24)</sup></b>		<b>Temperatures</b>	<b>Pressures</b>	
S1 <sup>(25)</sup>	Sliding sleeve, without over-pressure	All	A	★
S2	Sliding sleeve, with over-pressure	1, 2, 3	All	★
<b>Radial shaft sealing</b>		<b>Temperatures</b>	<b>Pressures</b>	
T1	FPM	1	A	★
T2	PTFE	1 and 2	A	★



**Table 2: Rosemount 2501 Ordering Information (continued)**

Alternative component material <sup>(26)</sup>		Temperatures	Applications	
CM1	Ball bearings in stainless steel	1, 2, and 3	All except S	★
<b>Housing heating</b> <sup>(20)</sup>				
HH1	Heating of housing, for temperature range -4 to -40 °F (-20 to -40 °C)			★
<b>Additional bearings</b>			<b>Applications</b>	
BR1 <sup>(27)</sup>	Additional bearings for paddle extension tube		M	★
<b>Extended product warranty</b>				
WR5	5-year limited warranty			★
<b>Typical model number: 2501 L 1 A A D 1 5 N N G A B 00000 N A D</b>				

- (1) Application code K requires a 4-in./DN100 flanged process connection.
- (2) Temperature-extended-shaft dimension is automatically added for this option, see [Table 7](#).
- (3) Maximum overpressure is 1.45 psi (0.1 bar).
- (4) Available when Process Operating Temperature code 1 is selected.
- (5) Available when Process Operation Pressure code A is selected.
- (6) Not available when Process Operating Temperature code 6 is selected.
- (7) Not available when Application Profile J and Process Operating Temperature codes 2 or 3 are selected.
- (8) Not available when Application Profile K and Materials of Construction: Process Connection code D is selected.
- (9) Not available when Application Profile K and Materials of Construction: Process Connection code A is selected.
- (10) Not available when Materials of Construction: Process Connection Material code S is selected.
- (11) Not available when Materials of Construction: Extension Material code A is selected.
- (12) Not available when Materials of Construction: Process Connection code A is selected.
- (13) Available when Operating Pressure codes A or B are selected.
- (14) Materials of Construction: Process Connection code A is not available when Process Connection Size code 4 is selected.
- (15) Not available when Process Operating Temperature codes 4, 5, or 6 is selected.
- (16) Not available when Operating Temperature code 4 is selected.
- (17) Please contact your local Emerson representative for the availability of this option.
- (18) Availability of measuring vanes depending on the selected Extension Material code.
- (19) Not available when Materials of Construction: Extension code F and Operating Temperature code 4 or 5 are selected.
- (20) Available when Power Supply code F or W is selected.
- (21) Available when Application Profile code K is selected.
- (22) Not available when customer-specified extended lengths are selected and their material is aluminum.
- (23) Available when Application Profile code L and Extension Material code D are selected.
- (24) Available when Application Profile code M is selected.
- (25) Sliding sleeve option code S1 must not be used in hazardous (classified) areas.
- (26) Not available when Process Connection Size code B is selected.
- (27) Additional bearings must be selected when Application Profile M and Materials of Construction: Extension code F are selected.

## Spares and accessories

The specification and selection of product materials, options, or components must be made by the purchaser of the equipment. See [Materials selection](#) for more information.

The starred offerings (★) represent the most common options and should be selected for best delivery. The non-starred offerings are subject to additional delivery lead time.

**Table 3: Spares**

Part number	Description	
02500-1000-0001	Motor: 230 Vac (50/60 Hz), 1 revolution/minute	★
02500-1000-0002	Motor: 230 Vac (50/60 Hz), 5 revolutions/minute	★
02500-1000-0003	Motor: 115 Vac (50/60 Hz), 1 revolution/minute	★
02500-1000-0004	Motor: 115 Vac (50/60 Hz), 5 revolutions/minute	★
02500-1000-0005	Motor: 48 Vac (50/60 Hz), 1 revolution/minute	★
02500-1000-0006	Motor: 48 Vac (50/60 Hz), 5 revolutions/minute	★
02500-1000-0007	Motor: 24 Vac (50/60 Hz), 1 revolution/minute	★
02500-1000-0008	Motor: 24 Vac (50/60 Hz), 5 revolutions/minute	★
02500-1000-0009	Motor: 24 Vdc, 1 revolution/minute	★
02500-1000-0010	Motor: 24 Vdc, 5 revolutions/minute	★
02500-1000-0011	Motor: 24 Vdc and 22 to 230 Vac (50/60 Hz), universal voltage, 1 revolution/minute	★
02500-1000-0012 <sup>(1)</sup>	Motor: 24 Vdc and 22 to 230 Vac (50/60 Hz), universal voltage, 1 revolution/minute, with fail-safe alarm	★
02500-1000-0013	Motor: 24 Vdc and 22 to 230 Vac (50/60 Hz), universal voltage, 1 revolution/minute, with housing heating (for temperatures of -20 to -40 °C)	★
02500-1000-0014 <sup>(1)</sup>	Motor: 24 Vdc and 22 to 230 Vac (50/60 Hz), universal voltage, 1 revolution/minute, with fail-safe alarm and housing heating (for temperatures of -20 to -40 °C)	★
02500-1000-0015	Motor: 24 Vdc and 22 to 230 Vac (50/60 Hz), universal voltage, 5 revolutions/minute,	★
02500-1000-0016 <sup>(1)</sup>	Motor: 24 Vdc and 22 to 230 Vac (50/60 Hz), universal voltage, 5 revolutions/minute, with fail-safe alarm	★
02500-1000-0017	Motor: 24 Vdc and 22 to 230 Vac (50/60 Hz), universal voltage, 5 revolutions/minute, with housing heating (for temperatures of -20 to -40 °C)	★
02500-1000-0018 <sup>(1)</sup>	Motor: 24 Vdc and 22 to 230 Vac (50/60 Hz), universal voltage, 5 revolutions/minute, with fail-safe alarm and housing heating (for temperatures of -20 to -40 °C)	★
02500-1000-0021	Paddle: 1.02 x 3.03 in. (26 x 77 mm), boot-shaped vane for M30x1.5	★
02500-1000-0022	Paddle: 1.57 x 3.86 in. (40 x 98 mm), boot-shaped vane, 304 stainless steel (1.4305)	★
02500-1000-0023	Paddle: 1.10 x 3.86 in. (28 x 98 mm), boot-shaped vane, 304 stainless steel (1.4305)	★
02500-1000-0024	Paddle: 1.38 x 4.17 in. (35 x 106 mm), boot-shaped vane, 316L stainless steel (1.4404)	★
02500-1000-0025	Paddle: 1.38 x 4.17 in. (35 x 106 mm), boot-shaped vane, 304 stainless steel (1.4305)	★
02500-1000-0026	Paddle: 1.57 x 3.86 in. (40 x 98 mm), boot-shaped vane, 316L stainless steel (1.4404)	★
02500-1000-0027	Paddle: 1.10 x 3.86 in. (28 x 98 mm), boot-shaped vane, 316L stainless steel (1.4404)	★

Table 3: Spares (continued)

Part number	Description	
02500-1000-0028	Paddle: 3.86 x 9.84 in. (98 x 250 mm), rectangular vane	★
02500-1000-0029	Paddle: 3.86 x 5.90 in. (98 x 150 mm), rectangular vane	★
02500-1000-0030	Paddle: 3.86 x 3.86 in. (98 x 98 mm), rectangular vane, 304 stainless steel (1.4305)	★
02500-1000-0031	Paddle: 1.97 x 9.84 in. (50 x 250 mm), rectangular vane	★
02500-1000-0032	Paddle: 1.97 x 5.90 in. (50 x 150 mm), rectangular vane	★
02500-1000-0033	Paddle: 1.97 x 3.86 in. (50 x 98 mm), rectangular vane	★
02500-1000-0034	Paddle: 3.86 x 3.86 in. (98 x 98 mm), rectangular vane, 316L stainless steel (1.4404)	★
02500-1000-0035	Paddle: 3.86 x 7.87 in. (98 x 200 mm), double-sided hinged vane, for 1½ and 1¼-in. BSPP, 303/304 stainless steel (1.4301/1.4305)	★
02500-1000-0036	Paddle: 3.86 x 7.87 in. (98 x 200 mm), double-sided hinged vane, for 1½ and 1¼-in. BSPP 316L stainless steel (1.4404)	★
02500-1000-0037	Paddle: 3.86 x 7.87 in. (98 x 200 mm), double-sided hinged vane, 28 mm for 1-in. BSPP and M32 hexagon nut, 303/304 stainless steel (1.4301/1.4305)	★
02500-1000-0038	Paddle: 3.86 x 3.93 in. (98 x 100 mm), single-sided hinged vane 37 mm for 1½ and 1¼-in. BSPP, 303/304 stainless steel (1.4301/1.4305)	★
02500-1000-0039	3.86 x 3.93 inches (98 x 100 mm), single-sided hinged vane, for 1½ and 1¼-in. BSPP, 316L stainless steel (1.4404)	★
02500-1000-0040	Paddle: 3.86 x 3.93 in. (98 x 100 mm), single-sided hinged vane 28 mm for 1-in. BSPP and M32 hexagon nut, 303/304 stainless steel (1.4301/1.4305)	★
02500-1000-0041	Paddle: 3.86 x 9.84 in. (98 x 250 mm), rubber vane (maximum 176 °F / 80 °C)	★
02500-1000-0042	Paddle: 1.57 x 3.15 in. (40 x 80 mm), rectangular notched vane	★
02500-1000-0044 <sup>(2)</sup>	Rod extension by 50 mm, ø10 mm	★
02500-1000-0045 <sup>(2)</sup>	Rod extension by 100 mm, ø10 mm	★
02500-1000-0046 <sup>(2)</sup>	Rod extension by 150 mm, ø10 mm	★
02500-1000-0047 <sup>(2)</sup>	Rod extension by 200 mm, ø10 mm	★
02500-1000-0048 <sup>(2)</sup>	Pendulum extension, 19.7 in. (500 mm), vertical installation	★
02500-1000-0049 <sup>(2)</sup>	Pendulum extension, 39.4 in. (1000 mm), vertical installation	★
02500-1000-0050 <sup>(2)</sup>	Rope extension, 787.7 in. (2000 mm), vertical installation	★
02500-1000-0051	Single rope, ø8 mm, with rope ends welded	★
02500-1000-0052	Fixing parts for rope extension, 787.7 in. (2000 mm)	★
02500-1000-0053 <sup>(2)</sup>	Rope weight for full-detection in large vessels (silos), ø30 mm rope	★
02500-1000-0054 <sup>(2)(3)</sup>	Rope holder for full-detection in large vessels (silos), medium resistance, ø22 mm	★
02500-1000-0055	M32 x 1.5 hexagon nut kit, aluminum, 1 off	★
02500-1000-0056	M32 x 1.5 hexagon nut kit, 303 stainless steel (1.4305), 1 off	★
02500-1000-0057	1-in. BSPP hexagon nut kit, aluminum, 1 off	★
02500-1000-0058	1-in. BSPP hexagon nut kit, 303 stainless steel (1.4305), 1 off	★

**Table 3: Spares (continued)**

Part number	Description	
02500-1000-0059	M30 x 1.5 hexagon nut kit, aluminum, 1 off	★
02500-1000-0060	M30 x 1.5 hexagon nut kit, 303 stainless steel (1.4305), 1 off	★
02500-1000-0061	1½-in. BSPP hexagon nut kit, aluminum, 1 off	★
02500-1000-0062	1¼-in. BSPP hexagon nut kit, aluminum, 1 off	★
02500-1000-0063	1½-in. BSPP hexagon nut kit, 303 stainless steel (1.4305), 1 off	★
02500-1000-0064	1¼-in. BSPP hexagon nut kit, 303 stainless steel (1.4305), 1 off	★
02500-1000-0068	Weather protection for housing	★

- (1) This module requires a sensor to detect the motor rotation, which is mounted inside the housing. Therefore it cannot be mounted into a housing where a different module was present before.
- (2) Delivery includes fixing parts.
- (3) Maximum of 4 kN load.

**Table 4: Accessories**

Part number	Description	
02500-7500-0003	Mounting kit 1 for DN100 PN6 and EN1092-1 flange with ø18 mm holes, containing: 4 off M16 x 60 mm screws (304-grade stainless steel) 4 off M16 nuts 4 off washers 1 off seal (non-food grade) for up to 464 °F (240 °C)	★
02500-7500-0006	Mounting kit 2 for DN100 PN6 and EN1092-1 flange with M16 threaded holes, containing: 4 off M16 x 40 mm screws (A2-grade stainless steel) 4 off M16 washers (A2-grade stainless steel) 1 off seal (non-food grade) for up to 464 °F (240 °C)	★
02500-7500-0009	Mounting kit 3 for DN100 PN16 and EN1092-1 flange with ø18 mm holes, containing: 8 off M16 x 60 mm screws (A2-grade stainless steel) 8 off M16 nuts (A2-grade stainless steel) 8 off M16 washers (A2-grade stainless steel) 1 off seal (non-food grade) for up to 464 °F (240 °C)	★
02500-7500-0012	Mounting kit 4 for DN100 PN16 and EN1092-1 flange with M16 threaded holes, containing: 8 off M16 x 40 mm screws (A2-grade stainless steel) 8 off M16 washers (A2-grade stainless steel) 1 off seal (non-food grade) for up to 464 °F (240 °C)	★
02500-7500-0013	Mounting kit 5 for 150 x 150 mm flange with ø18 mm holes, containing: 4 off M16 x 50 mm screws (A2-grade stainless steel) 4 off M16 nuts (A2-grade stainless steel) 4 off M16 washers (A2-grade stainless steel) 1 off seal (non-food grade) for up to 464 °F (240 °C)	★
02500-7500-0014	Mounting kit 6 for 150 x 150 mm flange with M16 threaded holes, containing: 4 off M16 x 30 mm screws (A2-grade stainless steel) 4 off M16 washers (A2-grade stainless steel) 1 off seal (non-food grade) for up to 464 °F (240 °C)	★

**Table 4: Accessories (continued)**

Part number	Description	
02500-7501-0002	Flat sealing gasket 1 for 1½-in. threaded process connection. Maximum operating temperature of 482 °F (250 °C)	★
02500-7501-0003	Flat sealing gasket 2 for 1½-in. threaded process connection, includes aluminum sealing face. Maximum operating temperature of 482 °F (250 °C)	★
02500-7501-0004	Flat sealing gasket 3 for 1½-in. threaded process connection, includes 316L (1.4404) sealing face. Maximum operating temperature of 482 °F (250 °C)	★

# Specifications

## Mechanical data

<b>Housing</b>	Aluminum housing, powder coated	
	Seal between housing and lid: NBR	
	Seal between housing and process connection: NBR	
	Nameplate: polyester film	
<b>Ingress Protection (IP)</b>	IP66, NEMA Type 4X:	
	Versions of the Rosemount 2501 with a stainless steel process connection (including extension), but <b>do not have</b> :	
	<ul style="list-style-type: none"> <li>■ Process temperatures exceeding 176 °F (80 °C)</li> <li>■ A sliding sleeve</li> <li>■ Application Profile code K in the full model number</li> </ul>	
	IP66, NEMA Type 4:	
	All other versions of the Rosemount 2501.	
<hr/>		
	<b>Note</b>	
	The IP66 rating is compliant with the standard IEC/EN/NBR 60529.	
<hr/>		
<b>Process connection materials</b>	Thread:	303 (1.4305) or 316L (1.4404) stainless steel or aluminum
	Tri Clamp:	303 (1.4305) or 316L (1.4404) stainless steel
	Flange (rectangular):	304 (1.4301) stainless steel or aluminum
	Flange (DN/ ANSI):	321 (1.4541) or 316L (1.4404) stainless steel; DN32 also made of aluminum
<b>Extended length materials</b>	Rosemount 2501L:	304/303 (1.4301/1.4305) or 316L (1.4404)
	Rosemount 2501M	304/303 (1.4301/1.4305) or 316L (1.4404) or aluminum
	Rosemount 2501R or Rosemount 2501S	303/316 (1.4305/1.4401) stainless steel
	Rosemount 2501J	304/303 (1.4301/1.4305) or 316L (1.4404) or aluminum
	Rosemount 2501K	304 (1.4301) stainless steel or aluminum
<b>Paddle shaft material</b>	All versions of Rosemount 2501:	304/303 (1.4301/1.4305) or 316L (1.4404) stainless steel
<b>Paddle and socket materials</b>	Boot-shaped vane:	304 (1.4301) or 316L (1.4404) stainless steel
	Rectangular vane:	304 (1.4301) or 316L (1.4404) stainless steel
	Hinged vane:	304/303/301 (1.4301/1.4305/1.4310) or 316L (1.4404)
	Rubber vane:	304 (1.4301)/rubber SBR
<b>Tolerance for paddle length</b>	±0.39 in. (±10 mm)	
<b>Bearings</b>	Ball bearing, dust-tight	
<b>Seals</b>	Radial rotary shaft sealing	Materials:  Standard for 662 °F (350 °C) and 1112 °F (600 °C) is graphite-based

Standard for 2012 °F (1100 °C) is ceramic

Standard for other process temperatures is NBR (Acrylnitril-Butadien-rubber)

Option code T1 is FPM

Option code T2 is PTFE

See also [Table 2](#)

<b>Friction clutch</b>	Protects the gear unit against impacts on the paddle (measuring vane)
<b>Speed of paddle rotation</b>	One revolution or five revolutions per minute
<b>Maximum noise level</b>	50 dBA
<b>Overall weight (approximated)</b>	See <a href="#">Table 5</a>

**Table 5: Overall Weights**

All weights are approximated and without flanges (except the Rosemount 2501K) and have the smallest paddle (measuring vane).

	Version				Extension	
	176 °F (80 °C)		302/482/662/1112 °F (150/250/350/600 °C)	2012 °F (1100 °C)	Aluminum <sup>(1)</sup>	Stainless steel <sup>(1)</sup>
	Aluminum <sup>(1)</sup>	Stainless steel <sup>(1)</sup>				
2501L	3.3 lbs (1.5 kg)	4.0 lbs (1.5 kg)	2.6 lbs (1.2 kg)	6.2 lbs (2.8 kg)	Not applicable	Not applicable
2501M	3.5 lbs (1.6 kg)	4.2 lbs (1.9 kg)	2.6 lbs (1.2 kg)	6.2 lbs (2.8 kg)	2.9 lbs per 39 in. (1.3 kg per m)	5.9 lbs per 39 in. (2.7 kg per m)
2501R, 2501S	5.3 lbs (2.4 kg)	5.9 lbs (2.7 kg)	2.6 lbs (1.2 kg)	-	-	0.6 lbs per 39 in. (0.25 kg per m)
2501K	8.8 lbs (4.0 kg) <sup>(2)</sup>	14.1 lbs (6.4 kg) <sup>(2)</sup>	2.6 lbs (1.2 kg)	Not applicable	0.9 lbs per 39 in. (0.4 kg per 100 mm)	1.3 lbs per 39 in. (0.6 kg per 100 mm)
2501J	3.5 lbs (1.6 kg)	4.2 lbs (1.9 kg)	2.6 lbs (1.2 kg)	-	0.3 lbs per 39 in. (0.15 kg per 100 mm)	0.7 lbs per 39 in. (0.3 kg per 100 mm)

(1) Material of the process connection.

(2) Version with flange 5.9 x 5.9 x 0.47 in. (150 x 150 x 12 mm) and the 9.84-in. (250 mm) standard paddle length.

## Electrical data

<b>Connection terminals</b>	Maximum 4 mm <sup>2</sup> (AWG12)
<b>Cable entry</b>	M20 × 1.5 screwed cable gland ½-in. NPT conduit connection Clamping range (diameter) of the factory provided cable glands: 0.24 to 0.47 in (6 to 12 mm) for M20 x 1.5
<b>Protection class</b>	I
<b>Overvoltage category</b>	II

<b>Pollution degree</b>	2 (inside housing)		
<b>Power supply</b> (ac and dc versions)	Ac version: 24, 48, 115, or 230 Vac ±10% (50/60 Hz) as ordered, maximum 4 VA External fuse: maximum 10 A, fast or slow, HBC, 250 V  Dc version: 24 Vdc ±15%, maximum 2.5 W External fuse not required		
<b>Power supply</b> (Universal Voltage)	24 Vdc ±15%, maximum 4 W 22 to 230 Vac (50/60 Hz) ±10%, maximum 10 VA		
<b>Signal output</b> (AC and DC versions)	Micro switch, SPDT contact Maximum 250 Vac, 5 A, non-inductive Maximum 30 Vdc, 4 A, non-inductive External fuse: Maximum 10 A, fast or slow, HBC, 250 V		
<b>Signal and alarm output</b> (Universal Voltage)	Relay DPDT contact Maximum 250 Vac, 5 A, non-inductive Maximum 30 Vdc, 4 A, non-inductive External fuse: Maximum 10 A, fast or slow, HBC, 250 V		
<b>Isolation</b>	Power to signal and alarm output: 2,225 Vrms Signal output to signal output (DPDT): 2,225 Vrms		
<b>Status indication</b>	Indicated by built-in LED (except for versions with an ac supply)		
<b>Output signal delay</b>	Output state	Delay (Vac and Vdc)	Delay (Universal voltage)
	Covered paddle*	1.3 s	1.5 s ±0 to 20 s (adjustable)
	Uncovered paddle*	0.2 s	0.2 s +/-0..60 s (adjustable)
	* After the paddle (measuring vane) has stopped rotating.		

## Operating conditions

### Temperature

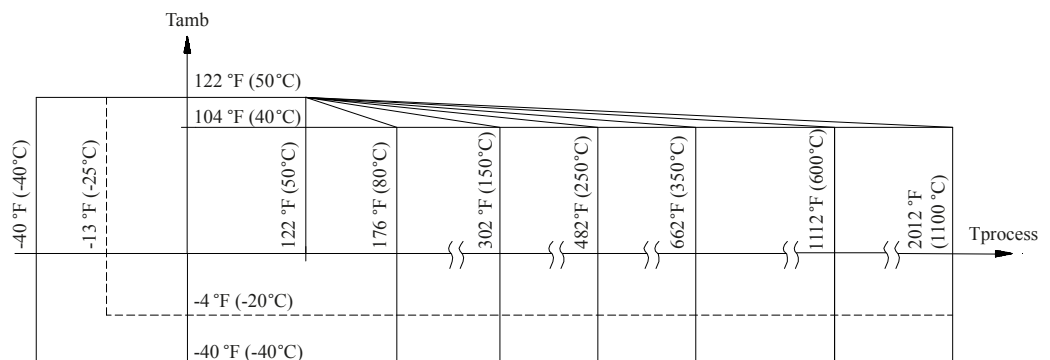

-40 °F (-40 °C) ambient and process temperature for versions with heating of housing.

662/1112 °F (350/600 °C) process temperature excludes Rosemount 2501K.

2012 °F (1100 °C) process temperature is for Rosemount 2501L and 2501M only.



**Maximum process pressure**

Operating Pressure code A: -13.1 to 11.6 psi (-0.9 to +0.8 bar)  
 Operating Pressure code B: -13.1 to 73 psi (-0.9 to +5 bar)  
 Operating Pressure code C: -13.1 to 145 psi (-0.9 to +10 bar)  
 Operating Temperature codes 5 or 6: -1.5 to 1.5 psi (-0.1 to +1 bar)

A PTFE seal is used for operating pressures exceeding 0.8 bar (11.6 psi).

**Minimum powder density (sensitivity)** See [Table 6](#).

**Table 6: Minimum Density Requirements and Sensitivity Settings**

Paddle	Minimum density in g/l = kg/m <sup>3</sup> (lb/ft <sup>3</sup> ) <sup>(1)</sup> (without guarantee)			
	Bulk material completely covering the vane		Bulk material covering the vane up to 3.93 in. (100 mm)	
	Spring adjustment		Spring adjustment	
	Fine	Medium (factory setting)	Fine	Medium (factory setting)
Boot-shaped vane 40 x 98	200 (12)	300 (18)	100 (60)	150 (9)
Boot-shaped vane 35 x 106	200 (12)	300 (18)	100 (60)	150 (9)
Boot-shaped vane 28 x 98	300 (18)	500 (30)	150 (9)	200 (12)
Boot-shaped 26 x 77	350 (21)	560 (33)	200 (12)	250 (15)
Vane 50 x 98	300 (18)	500 (30)	150 (9)	250 (15)
Vane 50 x 150	80 (4.8)	120 (7.2)	40 (2.4)	60 (3.6)
Vane 50 x 250	30 (1.8)	50 (3)	15 (0.9)	25 (1.5)
Vane 98 x 98	100 (60)	150 (9)	50 (3)	75 (4.5)
Vane 98 x 150	30 (1.8)	50 (3)	15 (0.9)	25 (1.5)
Vane 98 x 250	20 (1.2)	30 (1.8)	15 (0.9)	15 (0.9)
Hinged vane 98 x 200 b=37 double-sided	70 (4.2)	100 (60)	35 (2.16)	50 (3)
Hinged vane 98 x 200 b=28 double-sided	100 (60)	150 (9)	50 (3)	75 (4.5)
Hinged vane 98 x 100 b=37 single-sided	200 (12)	300 (18)	100 (60)	150 (9)
Hinged vane 98 x 100 b=28 single-sided	300 (18)	500 (30)	150 (9)	250 (15)

(1) For versions with the **Heating of housing** option, the above-mentioned data must be multiplied by 1.5.

**Limitations for bulk material** Very few limitations.

**Maximum permitted mechanical torque (at 104 °F, 40 °C)**

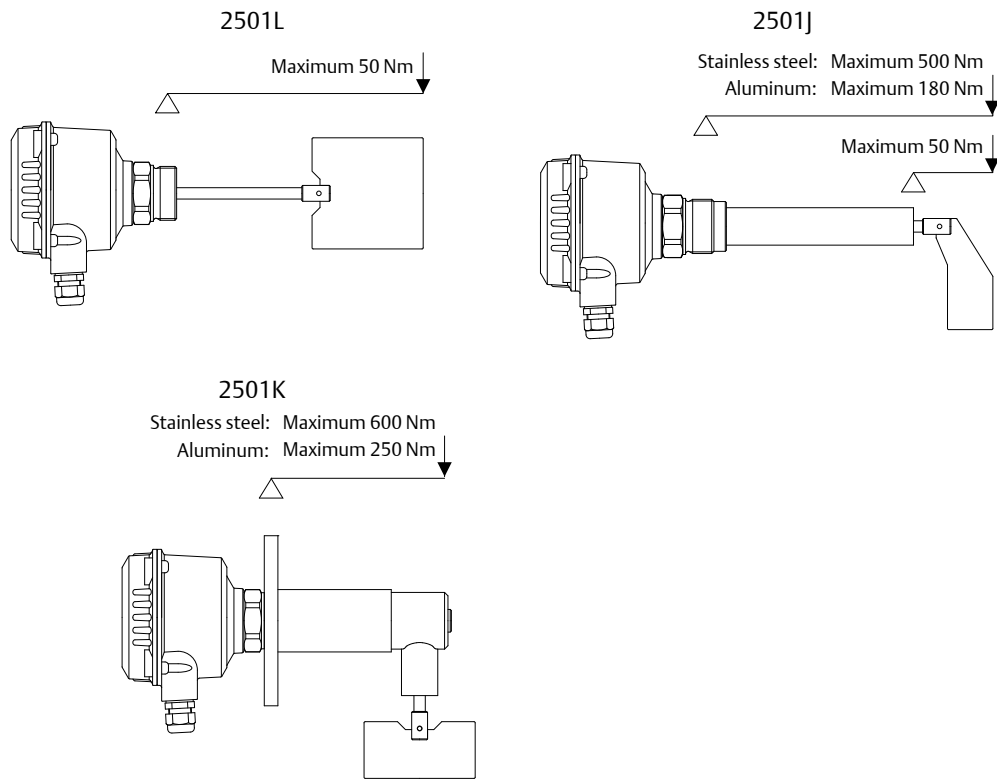

Contact Emerson for the maximum torque of a Rosemount 2501 with a reinforced rib (Welded Flange option code W2).

Take protective measures, such as fitting an angled shield (reverse V shape) to the silo or selecting an extension tube option, when there are high mechanical forces

<b>Maximum tractive force</b>	Rosemount 2501L with a pendulum shaft:	400 N (only when used as a full-silo detector)
	Rosemount 2501R and 2501J:	4 kN (standard rope type)      28 kN (reinforced rope type)

**Ventilation**      Ventilation is not required.

**Vibration**      1.5 (m/s<sup>2</sup>)/ Hz according to EN 60068-2-64

**Relative humidity**      0-100%, suitable for outdoor use

**Maximum altitude**      6562 ft. (2000 m)

**Expected product lifetime**      The following factors have a negative influence on the expected product lifetime:  
High ambient- and process temperatures, corrosive environments, high plant vibrations, high flow rate of abrasive bulk material passing the sensor element, and high amount of measurement cycles.

## Transport and storage

### Transport

Refer to the instructions as stated on the transport packaging, otherwise the products may get damaged.

Transport temperature: -40 to +176 °F (-40 to +80 °C)

Transport humidity: 20 to 85%

Always inspect the received goods for any damage occurred during shipment from the factory. Notify Emerson of damaged goods as soon as possible.

### Storage

Products must be stored at a dry and clean place. They must be protected from influence of corrosive environments, vibrations, and exposure to direct sunlight.

Storage temperature: -40 to +176 °F (-40 to +80 °C)

Storage humidity: 20 to 85%

## Product certifications

### European Union directive information

A copy of the EU Declaration of Conformity can be found at the end of the Rosemount 2501 [Quick Start Guide](#) . The most recent revision of the EU Declaration of Conformity can be found at [Emerson.com/Rosemount](https://www.emerson.com/Rosemount).

# Dimensional drawings

**Figure 2: Rosemount 2501 Paddle Level Switch (Standard Length, Application Profile code L)**

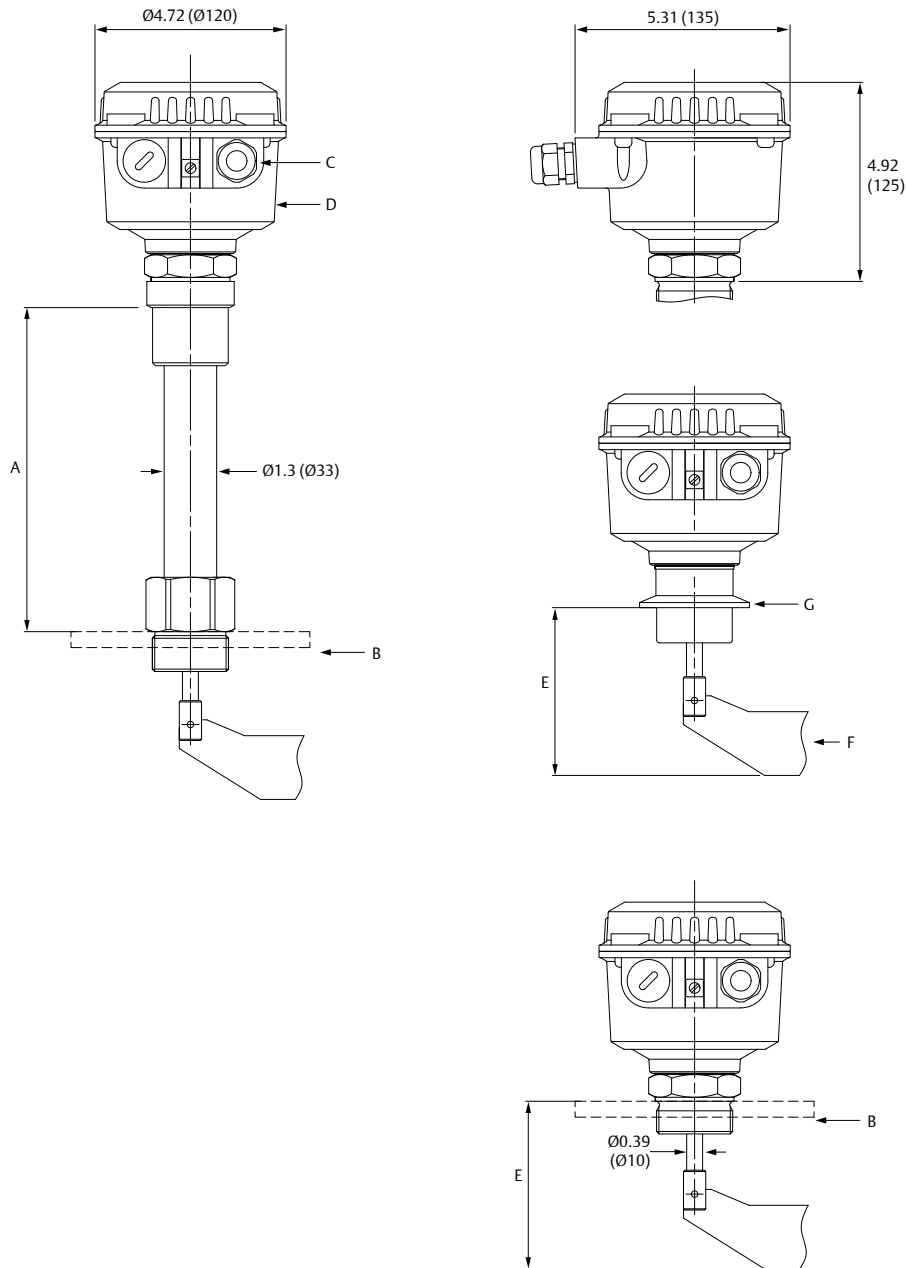

- A. Temperature-extended-shaft dimension. See [Table 7](#)
- B. Threaded or flanged process connection
- C. M20 or 1/2-in. NPT cable entry
- D. Aluminum housing
- E. Measuring vane (paddle) dimension. See [Table 8](#)
- F. Measuring vane (paddle) options
- G. Tri Clamp process connection

Dimensions are in inches (millimeters).

**Table 7: Dimension A**

Process temperature	Dimension A
302 °F (150 °C)	7.87 (200)
482 °F (250 °C)	7.87 (200)
662 °F (350 °C)	11.81 (300)
1112 °F (600 °C)	15.74 (400)
2012 °F (1100 °C)	27.56 (700)

**Table 8: Dimension E**

Extension length	Measuring vanes allowed
2.76 (70)	Option P only
3.94 (100)	Options A, B, C, D, L, M and N
5.91 (150)	All
7.87 (200)	All
9.84 (250)	All
11.81 (300)	All

Figure 3: Rosemount 2501 Paddle Level Switch (Extended Tube/Shaft Length, Application Profile code M)

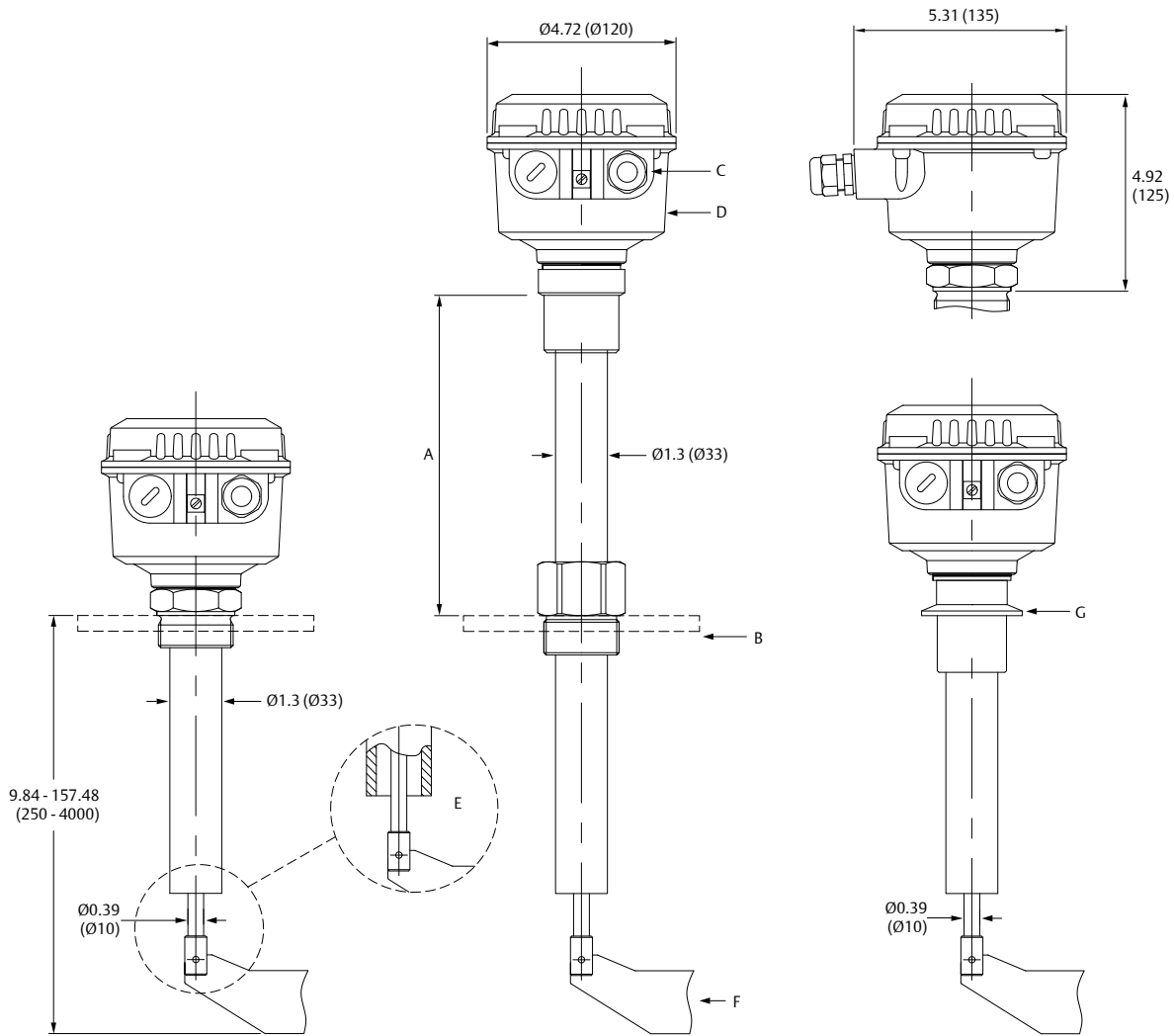

- A. Temperature-extended-shaft dimension. See [Table 7](#)
- B. Threaded or flanged process connection
- C. M20 or 1/2-in. NPT cable entry
- D. Aluminum housing
- E. Without sealing and bearing at the tube end
- F. Measuring vane (paddle) options
- G. 2-in. Tri Clamp process connection (maximum 482 °F / 250 °C)

Dimensions are in inches (millimeters).

Figure 4: Rosemount 2501 Paddle Level Switch (Rope-Extended Length, Application Profile codes R and S)

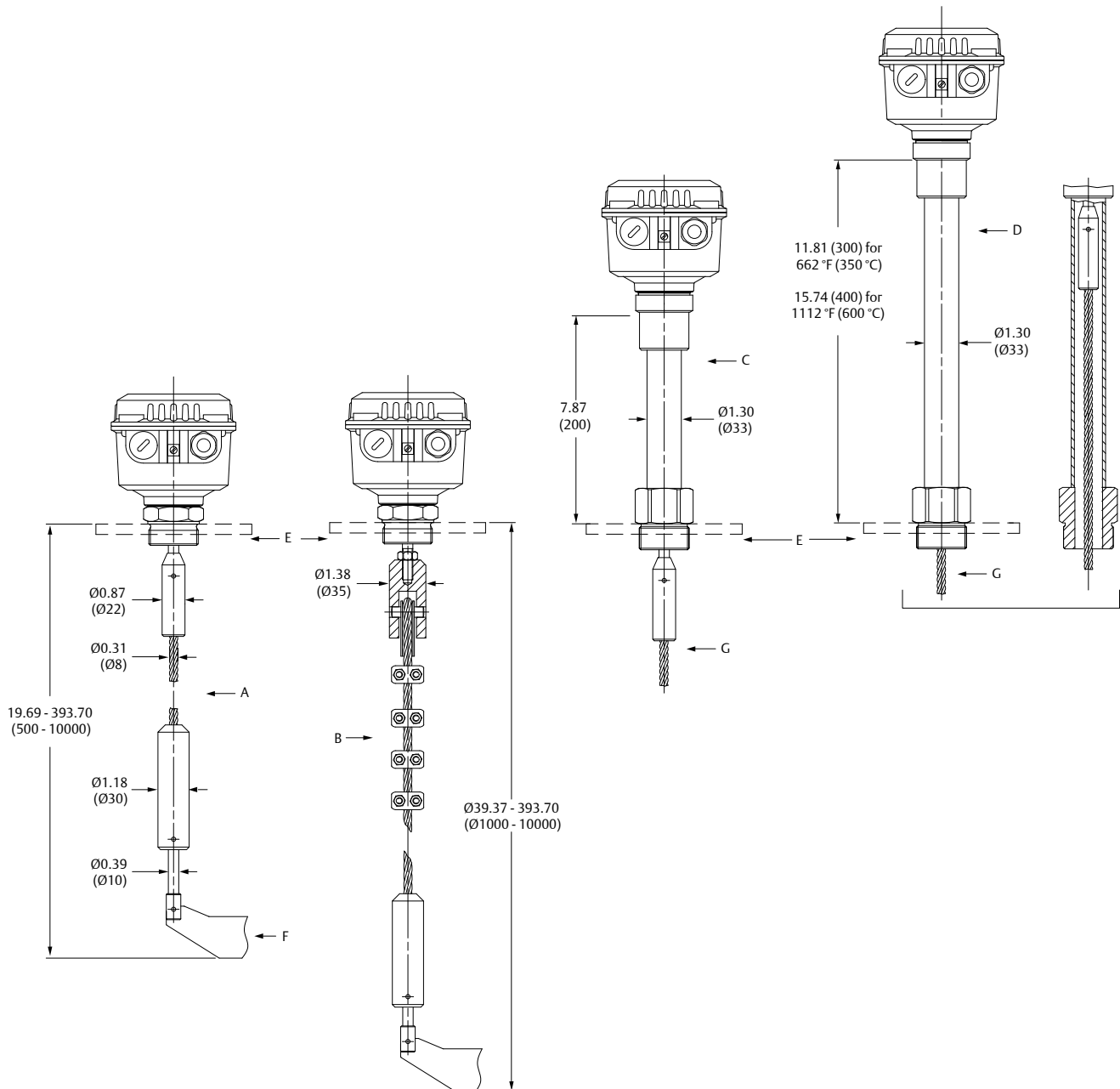

- A. Standard type of rope-extended paddle (maximum 4 kN load)
- B. Reinforced type of rope-extended paddle (maximum 28 kN load)
- C. Temperature-extended shaft for  $302/482^\circ\text{F}$  ( $150/250^\circ\text{C}$ )
- D. Temperature-extended shaft for  $662/1,112^\circ\text{F}$  ( $350/600^\circ\text{C}$ )
- E. Threaded or flanged process connection
- F. Measuring vane (paddle) options
- G. Rope-extended paddle

Dimensions are in inches (millimeters).



**Figure 5: Rosemount 2501 Paddle Level Switch (Application Profile code K)**

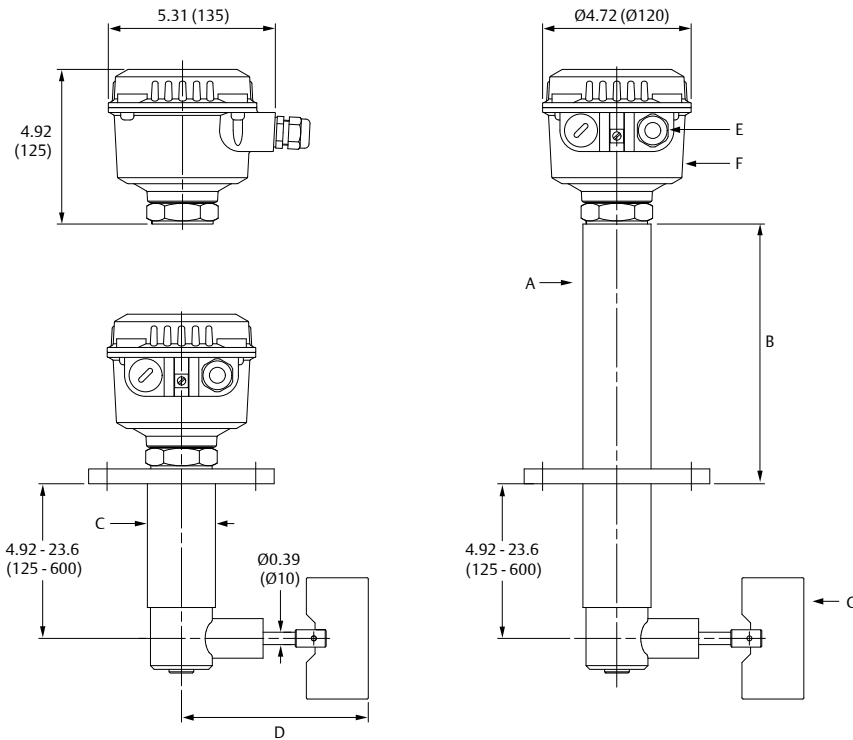

- A. Temperature extended shaft
- B. Dimension B. See [Table 9](#)
- C. Dimension C. See [Table 10](#)
- D. Dimension D. See [Table 11](#)
- E. M20 or 1/2-in. NPT cable entry
- F. Aluminum housing
- G. Measuring vane (paddle) options

Dimensions are in inches (millimeters).

**Table 9: Dimensions B**

Process temperature	Dimension B
176 °F (80 °C), 11.6 psi (0.8 bar)	0.39 in. (10 mm)
176 °F (80 °C), 73 or 145 psi (5 or 10 bar)	2.95 in. (75 mm)
302 or 482 °F (150 or 250 °C), 11.6, 73 or 145 psi (0.8, 5, or 10 bar)	8.27 in. (210 mm)

**Table 10: Dimensions C**

Material	Dimension C
Steel	2.17 in. (55 mm)
Aluminum	2.36 in. (60 mm)

**Table 11: Dimensions D**

Measuring vane (paddle)	D dimension
1.97 in. x .. in. (50 mm x .. mm)	5.47 in. (139 mm)
3.86 in. x ..in. (98 mm x .. mm)	7.36 in. (187 mm)

**Figure 6: Rosemount 2501 Paddle Level Switch (Application Profile code J)**

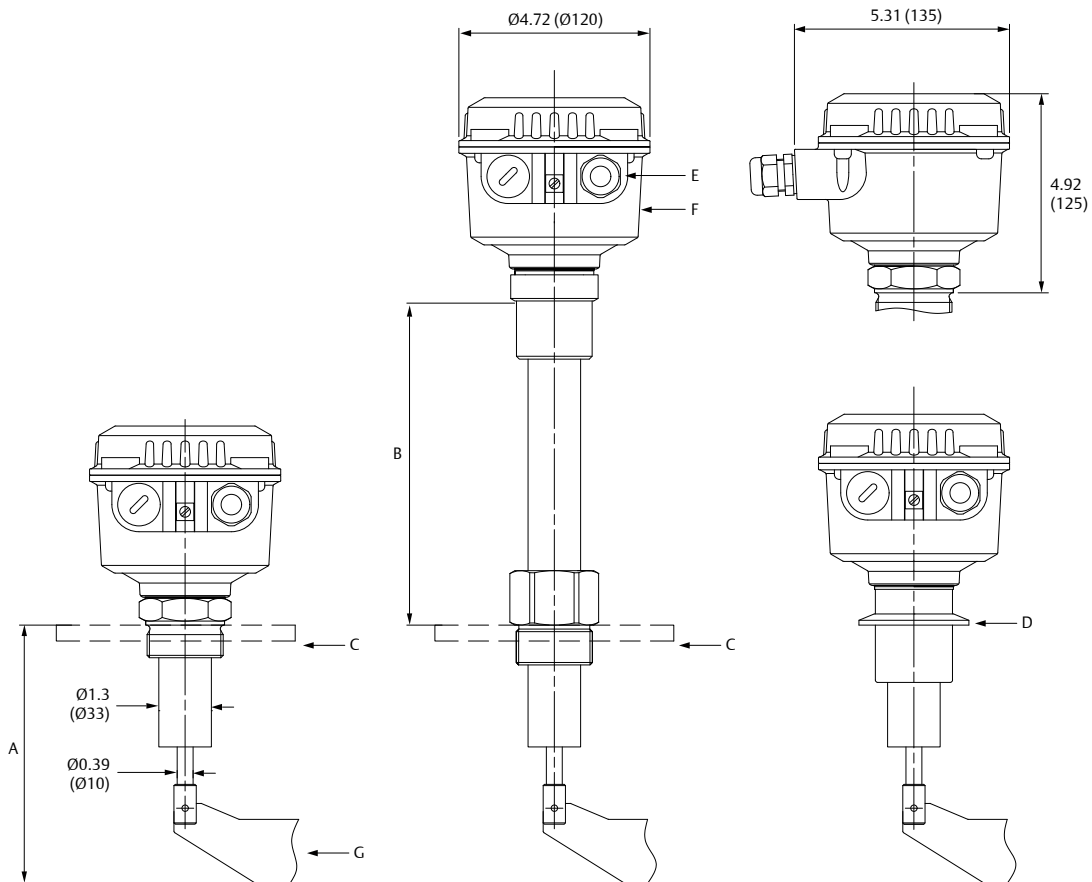

- A. Dimension A. See [Table 13](#)
- B. Dimension B. See [Table 12](#)
- C. Threaded or flanged process connection
- D. Tri Clamp process connection
- E. M20 or 1/2-in. NPT cable entry
- F. Aluminum housing
- G. Measuring vane (paddle) options

Dimensions are in inches (millimeters).

**Table 12: Dimension A**

Process temperature	A dimension
302 °F (150 °C)	7.87 in. (200 mm)
482 °F (250 °C)	7.87 in. (200 mm)

**Table 12: Dimension A (continued)**

Process temperature	A dimension
662 °F (350 °C)	11.81 in. (300 mm)
1112 °F (600 °C)	15.74 in. (400 mm)

**Table 13: Dimension E**

Extension length	Measuring vanes allowed
5.91 (150)	Options C, D, L, M and N
7.87 (200)	All
9.84 (250)	All
11.81 (300)	All

Other lengths: Minimum 13.78 (350), maximum 23.62 (600)

**Table 14: Paddles (measuring vanes)**

Double-sided vanes have twice the measuring rate, compared to single-sided vanes.

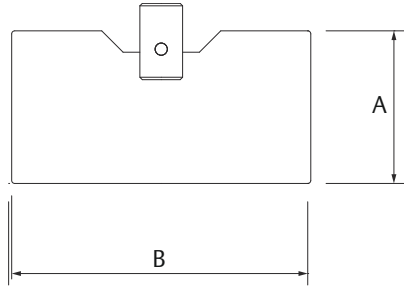
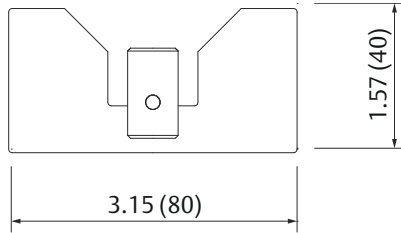
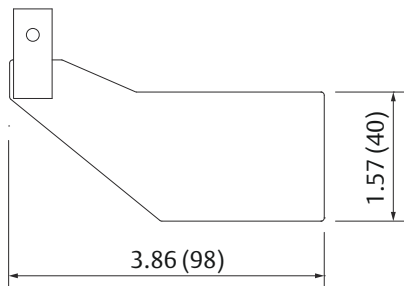
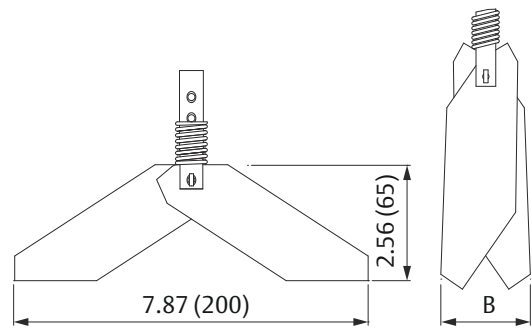
<p><b>Figure 7: Rectangular Vane - Codes L, M, N, P, Q, R</b></p>  <p>The diagram shows a rectangular vane with a central circular hole. Dimension A is the height of the vane, and dimension B is the width. The vane has a small notch at the top center.</p>	<p><b>Figure 8: Rectangular Notched Vane 40 x 80 mm - Code K</b></p>  <p>The diagram shows a rectangular vane with a central circular hole and a notch at the top center. The width is 3.15 (80) mm and the height is 1.57 (40) mm.</p>
<p><b>Figure 9: Boot-shaped Vane 40 x 98 mm - Code D</b></p>  <p>The diagram shows a boot-shaped vane with a central circular hole. The width is 3.86 (98) mm and the height is 1.57 (40) mm.</p>	<p><b>Figure 10: Hinged Vane 98 x 200 mm, Double-sided - Code V</b></p>  <p>The diagram shows a hinged vane with a central circular hole and a hinge mechanism. The width is 7.87 (200) mm and the height is 2.56 (65) mm. A second view shows the vane with a threaded rod and nut.</p>

**Table 14: Paddles (measuring vanes) (continued)**

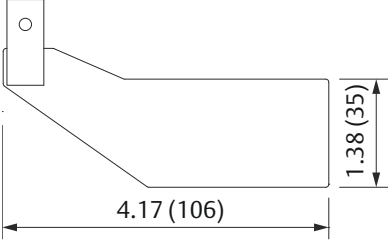
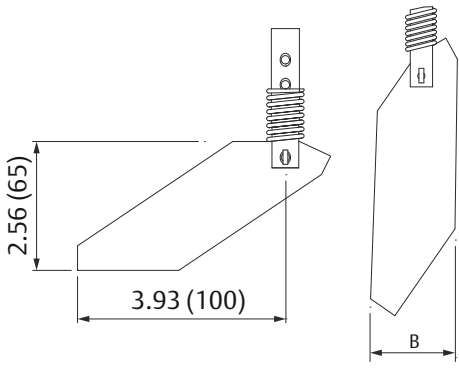
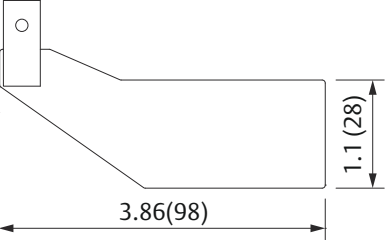
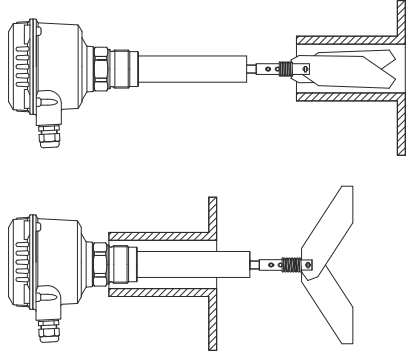
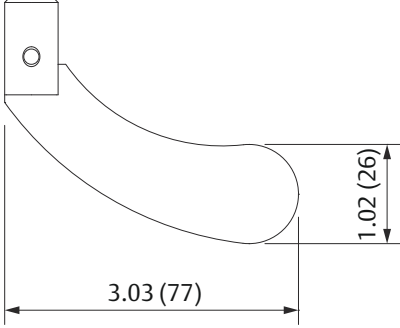
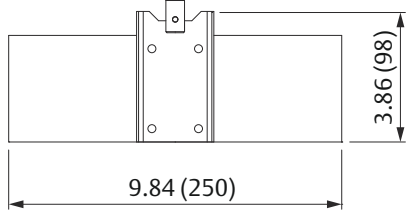
<p><b>Figure 11: Boot-shaped Vane 35 x 106 mm - Code C</b></p> 	<p><b>Figure 12: Boot-shaped Vane 98 x 100 mm, Single-sided - Code U</b></p> 
<p><b>Figure 13: Boot-shaped Vane 28 x 98 mm - Code B</b></p> 	<p><b>Figure 14: Hinged Vane (Long Socket)</b></p> 
<p><b>Figure 15: Boot-shaped Vane 26 x 77 mm - Code A</b></p> 	<p><b>Figure 16: Rubber Vane 98 x 250 mm - Code W</b></p> 

Dimensions are in inches (millimeters).

See [Table 15](#) for A and B dimensions.

**Table 15: Measuring Vane Dimensions A and B**

Code	Type	Dimension A	Dimension B
L	Rectangular	1.97 (50)	3.86 (98)
M	Rectangular	1.97 (50)	5.9 (150)

**Table 15: Measuring Vane Dimensions A and B (continued)**

Code	Type	Dimension A	Dimension B
N	Rectangular	1.97 (50)	9.84 (250)
P	Rectangular	3.86 (98)	3.86 (98)
Q	Rectangular	3.86 (98)	5.90 (150)
R	Rectangular	3.86 (98)	9.84 (250)
U	Hinged, single-sided		1.46 (37) for 1½ in. or 1¼ in.
V	Hinged, double-sided		1.1 (28) for 1 in. or M32x1.5





#### Global Headquarters

Emerson Automation Solutions  
6021 Innovation Blvd.  
Shakopee, MN 55379, USA

+1 800 999 9307 or +1 952 906 8888  
+1 952 204 8889  
RFQ.RMD-RCC@Emerson.com

#### North America Regional Office

Emerson Automation Solutions  
8200 Market Blvd.  
Chanhassen, MN 55317, USA

+1 800 999 9307 or +1 952 906 8888  
+1 952 204 8889  
RMT-NA.RCCRFQ@Emerson.com

#### Latin America Regional Office

Emerson Automation Solutions  
1300 Concord Terrace, Suite 400  
Sunrise, FL 33323, USA

+1 954 846 5030  
+1 954 846 5121  
RFQ.RMD-RCC@Emerson.com

#### Europe Regional Office

Emerson Automation Solutions Europe  
GmbH  
Neuhofstrasse 19a P.O. Box 1046  
CH 6340 Baar  
Switzerland

+41 (0) 41 768 6111  
+41 (0) 41 768 6300  
RFQ.RMD-RCC@Emerson.com

#### Asia Pacific Regional Office

Emerson Automation Solutions  
1 Pandan Crescent  
Singapore 128461

+65 6777 8211  
+65 6777 0947  
Enquiries@AP.Emerson.com

#### Middle East and Africa Regional Office

Emerson Automation Solutions  
Emerson FZE P.O. Box 17033  
Jebel Ali Free Zone - South 2  
Dubai, United Arab Emirates

+971 4 8118100  
+971 4 8865465  
RFQ.RMTMEA@Emerson.com

 [Linkedin.com/company/Emerson-Automation-Solutions](https://www.linkedin.com/company/Emerson-Automation-Solutions)

 [Twitter.com/Rosemount\\_News](https://twitter.com/Rosemount_News)

 [Facebook.com/Rosemount](https://www.facebook.com/Rosemount)

 [Youtube.com/user/RosemountMeasurement](https://www.youtube.com/user/RosemountMeasurement)

©2020 Emerson. All rights reserved.

Emerson Terms and Conditions of Sale are available upon request. The Emerson logo is a trademark and service mark of Emerson Electric Co. Rosemount is a mark of one of the Emerson family of companies. All other marks are the property of their respective owners.