

Rosemount™ 2140 and 2140:SIS Level Detectors

Vibrating Fork



Contents

About this guide.....	3
Installation.....	5
Prepare the electrical connections.....	11
Connect wiring and power-up.....	14
Configuration.....	19

1 About this guide

This Quick Start Guide provides basic guidelines for the Rosemount™ 2140 and 2140:SIS Level Detectors. Refer to the Rosemount 2140 and 2140:SIS [Reference Manual](#) for more instructions. The manual and this guide are also available electronically at [Emerson.com/Rosemount](https://www.emerson.com/Rosemount).

⚠ WARNING

Failure to follow safe installation and servicing guidelines could result in death or serious injury.

- Ensure the level detector is installed by qualified personnel and in accordance with applicable code of practice.
- Use the level detector only as specified in this manual. Failure to do so may impair the protection provided by the level detector.
- The weight of a level detector with a heavy flange and extended fork length may exceed 37 lb. (18 kg). A risk assessment is required before carrying, lifting, and installing the level detector.
- For installations in hazardous locations, the level detector must be installed according to the Rosemount™ 2140 and 2140:SIS Level Detectors [Product Certifications document](#)

Explosions could result in death or serious injury.

- Verify that the operating atmosphere of the level detector is consistent with the appropriate hazardous locations certifications.
 - Before connecting a handheld communicator in an explosive atmosphere, ensure that the instruments in the loop are installed in accordance with intrinsically safe or non-incendive field wiring practices.
 - In explosion-proof/flameproof and non-incendive/type n installations, do not remove the housing covers when power is applied to the level detector.
 - Both housing covers must be fully engaged to meet flameproof/explosion-proof requirements.
-

⚠ WARNING

Electrical shock could cause death or serious injury.

- Avoid contact with the leads and terminals. High voltage that may be present on leads can cause electrical shock.
- Ensure the power to the level detector is off, and the lines to any other external power source are disconnected or not powered while wiring the level detector.
- Ensure the wiring is suitable for the electrical current and the insulation is suitable for the voltage, temperature, and environment.

Process leaks could result in death or serious injury.

- Ensure the level detector is handled carefully. If the process seal is damaged, gas might escape from the vessel (tank) or pipe.

⚠ WARNING**Physical access**

Unauthorized personnel may potentially cause significant damage to and/or misconfiguration of end users' equipment. This could be intentional or unintentional and needs to be protected against.

Physical security is an important part of any security program and fundamental to protecting your system. Restrict physical access by unauthorized personnel to protect end users' assets. This is true for all systems used within the facility.

⚠ CAUTION**Hot surfaces**

The flange and process seal may be hot at high process temperatures.

Allow to cool before servicing.

2 Installation

2.1 Fork alignment in a pipe installation

Figure 2-1: Correct Fork Alignment for Pipe Installation

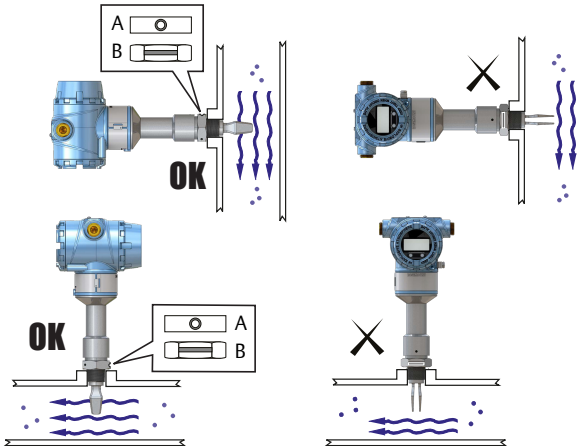

- A. Tri Clamp process connections have a circular notch
- B. Threaded process connections have a groove

2.2 Fork alignment in a vessel (tank) installation

Figure 2-2: Correct Fork Alignment for Vessel (Tank) Installation

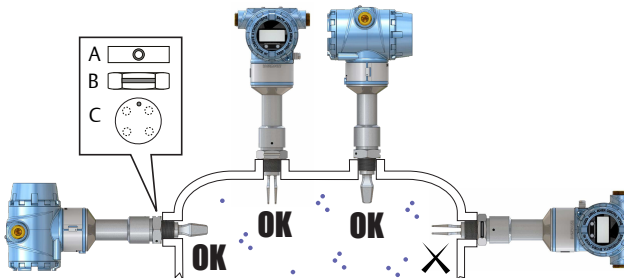

- A. Tri Clamp process connections have a circular notch
- B. Threaded process connections have a groove
- C. Flanged process connections have a circular notch

2.3 Mounting the threaded version

2.3.1 Seal and protect the threads

- Use anti-seize paste or PTFE tape according to site procedures. A gasket may be used as a sealant for BSPP (G) threaded connections.

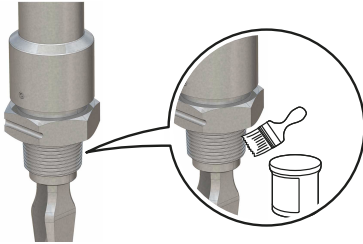

2.3.2 Threaded vessel (tank) or pipework connection

- Vertical installation.

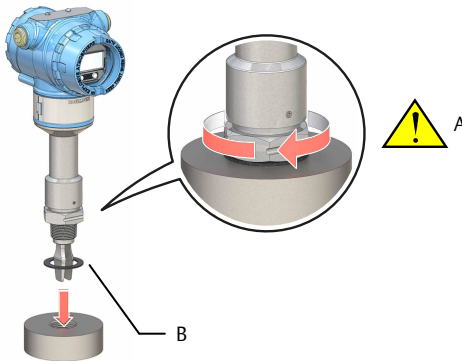

- Horizontal installation.

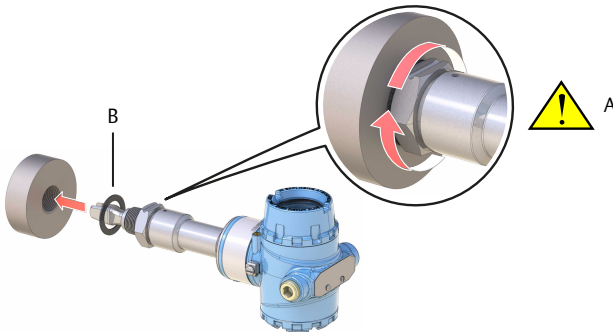

A. Tighten using the hexagon nut only

B. Gasket for BSPP (G) threaded connection

2.3.3 Threaded flange connection

Procedure

1. Place the customer-supplied flange and gasket on the vessel (tank) nozzle.

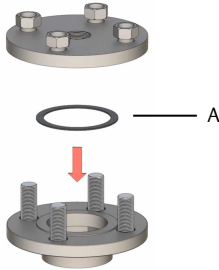

A. Gasket (customer supplied)

2. Tighten the bolts and nuts with sufficient torque for the flange and gasket.

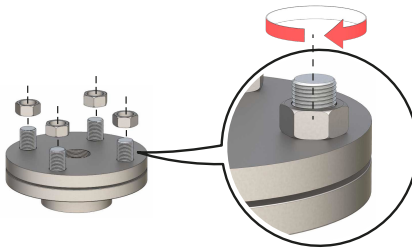

3. Screw the level detector into the flange thread.

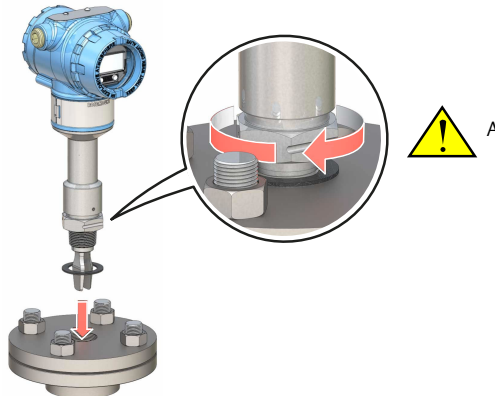

A. Tighten using the hexagon nut only

2.4 Mounting the flanged version

Procedure

1. Lower the level detector into the nozzle.

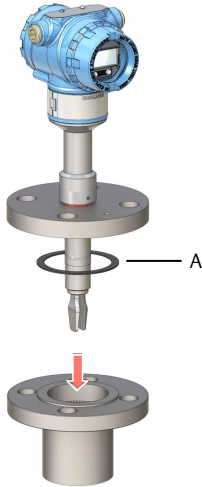

A. Gasket (customer supplied)

2. Tighten the bolts and nuts with sufficient torque for the flange and gasket.

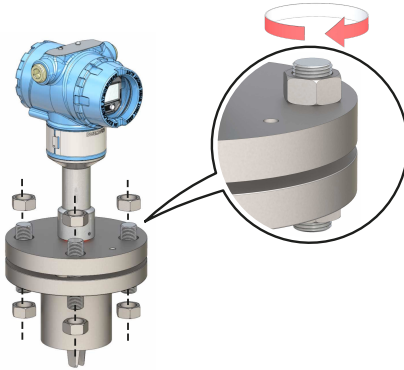

2.5 Mounting the Tri Clamp version

Procedure

1. Lower the level detector into the flange face.

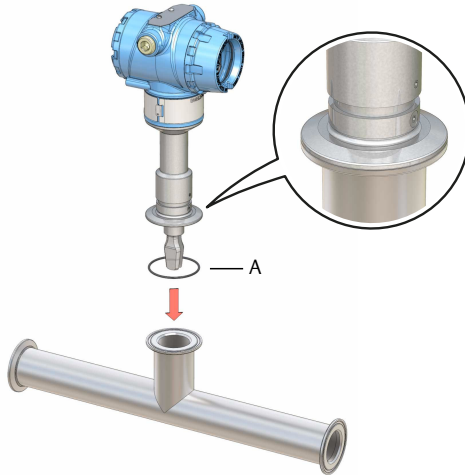

A. Seal (supplied with Tri Clamp)

2. Fit the Tri Clamp.

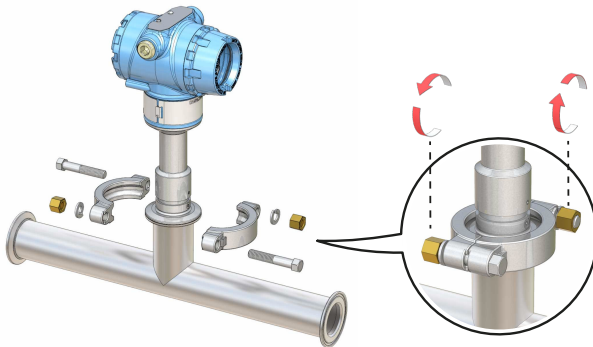

2.6 Adjust display orientation (optional)

To improve field access to wiring or to better view the optional LCD display:

Procedure

1. Loosen the set screw until the level detector housing can rotate smoothly.
Do not unscrew all the way. Rotating the housing, without this screw in place, can damage the internal wiring.
2. First, rotate the housing clockwise to the desired location.
If the desired location cannot be achieved due to thread limit, rotate the housing counterclockwise.
3. Re-tighten the set screw.

Figure 2-3: Housing Rotation



Do not attempt to rotate the display beyond the thread limits

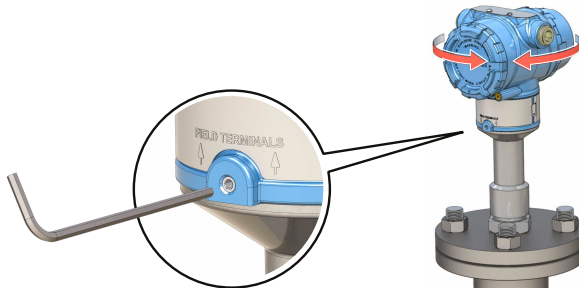

 $H^{3/32}$ in. torque 30 in-lb (3 Nm)

3 Prepare the electrical connections

Note

See the Rosemount 2140 [Product Data Sheet](#) for all electrical specifications.

3.1 Cable selection

Use 24–14 AWG wiring. Twisted-pairs and shielded wiring is recommended for environments with high EMI (electromagnetic interference). Two wires can be safely connected to each terminal screw.

3.2 Cable glands/conduits

For intrinsically safe, explosion-proof/flameproof, and dust-proof installations, only use certified cable glands or conduit entry devices. Ordinary location installations can use suitably rated cable glands or conduit entry devices to maintain the Ingress Protection (IP) rating.

Unused conduit entries must always be sealed with a suitably rated blanking/stopping plug.

Note

Do not run signal wiring in conduit or open trays with power wiring or near heavy electrical equipment.

3.3 Power supply

Each level detector operates on 10.5 – 42.4 Vdc (10.5 – 30 Vdc in Intrinsically Safe installations) at the level detector terminals.

3.4 Power consumption

Maximum of 1 W, and current maximum is 23 mA.

3.5 Hazardous areas

When the level detector is installed in hazardous areas (classified locations), local regulations and the conditions-of-use specified in applicable certificates must be observed. Review the Rosemount 2140 [Product Certifications document](#) for information.

3.6 Load limitations

For HART[®] communications, a minimum load resistance of 250 Ω is required.

The maximum loop resistance is determined by the voltage level of the external power supply (see [Figure 3-1](#)).

Figure 3-1: Load Limitations

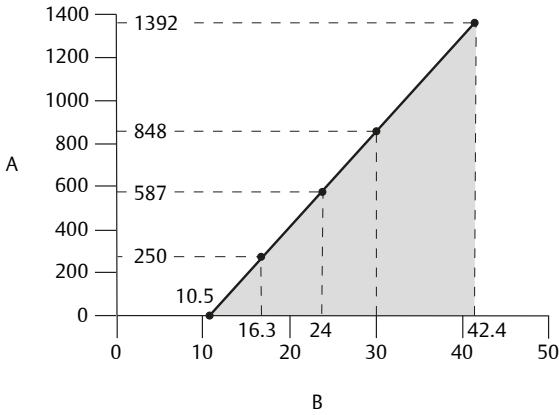

Maximum loop resistance = $43.5 * (\text{external power supply voltage} - 10.5)$

- A. Loop resistance in Ohms (Ω)
- B. External power supply voltage (Vdc)

3.7 Wiring diagram

Figure 3-2: 4-20 mA/HART® Communication

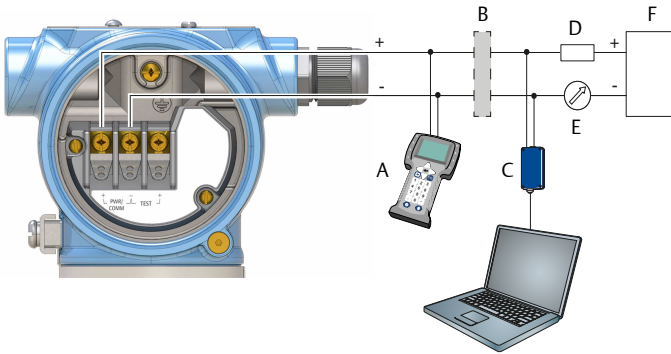

- A. Handheld communicator
- B. Approved IS barrier (for Intrinsically Safe installations only)
- C. HART modem
- D. Load resistance ($\geq 250 \Omega$)
- E. Current meter
- F. Power supply

3.8 Grounding

⚠ Always ground the housing in accordance with national and local laws.

3.8.1 Grounding using the cable shield

Make sure the instrument cable shield is:

- Trimmed close and insulated from touching the level detector housing.
- Continuously connected throughout the segment.
- Connected to a good earth ground at the power supply end.

Figure 3-3: Signal Cable Shield Grounding at Power Supply End

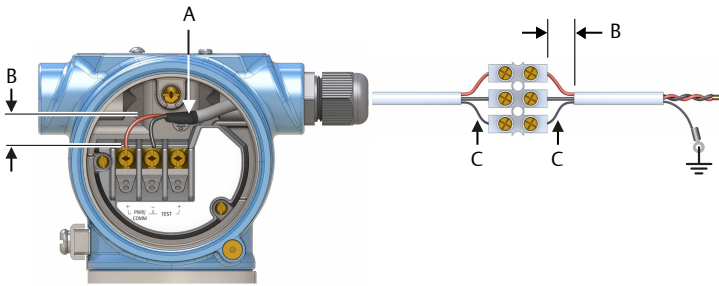

- A. Trim shield and insulate
- B. Minimize distance
- C. Trim shield
- D. Connect shield back to the power supply ground

3.8.2 Grounding the housing of a level detector

Figure 3-4: Ground Screws

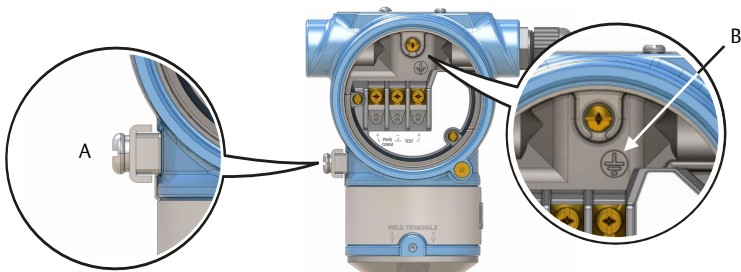

- A. External ground screw
- B. Internal ground screw

4 Connect wiring and power-up

Procedure

1. ⚠ Verify the power supply is disconnected.
2. Remove the field terminals cover.

In an explosion-proof/flameproof installation, do not remove the level detector covers when power is applied to the unit. Covers are also not to be removed in extreme environmental conditions.

- a) Turn the jam screw clockwise until it is completely threaded into the housing.

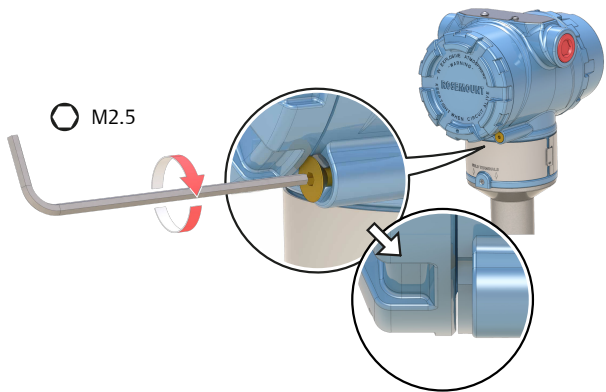

- b) Turn the cover counter-clockwise until it is removed from the housing.

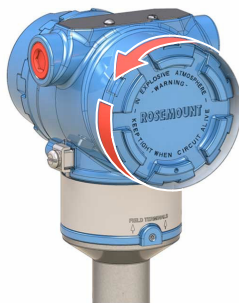

- c) Keep the cover O-ring safe. Replace the O-ring if it is worn or damaged.

3. Remove the plastic plugs.

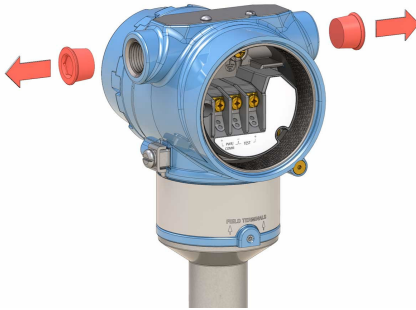

4. Pull the cable through the cable gland/conduit.

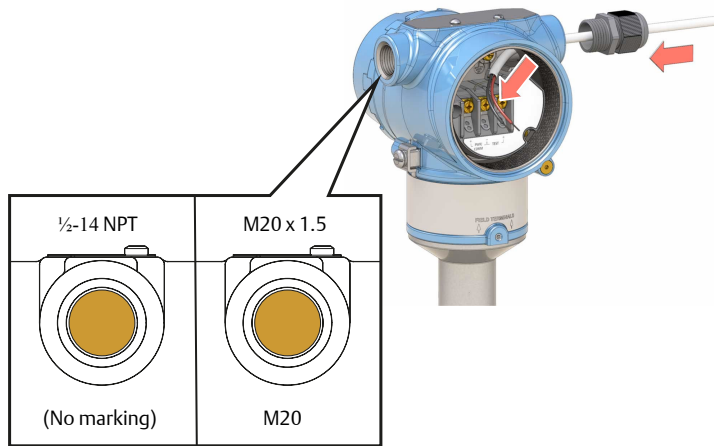

5. Connect the cable wires (see [Wiring diagram](#)).

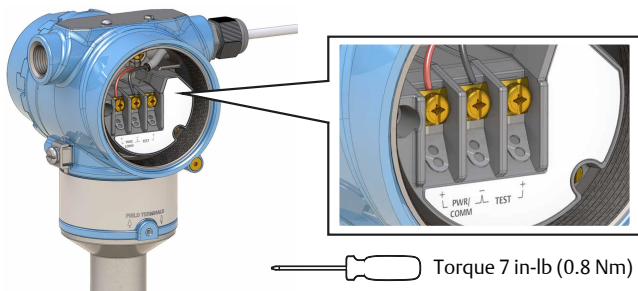

6. Ensure proper grounding (see [Grounding](#)).

- 7. Tighten the cable gland.
Apply PTFE tape or other sealant to the threads.

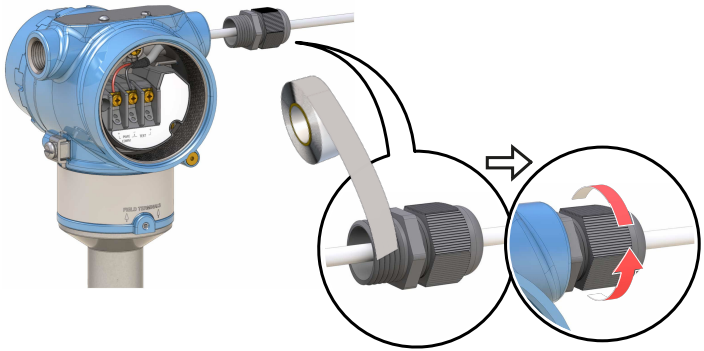

Note

Make sure to arrange the wiring with a drip loop.



- 8. Plug and seal the unused conduit connection to avoid moisture and dust accumulation inside the housing.
Apply PTFE tape or other sealant to the threads.

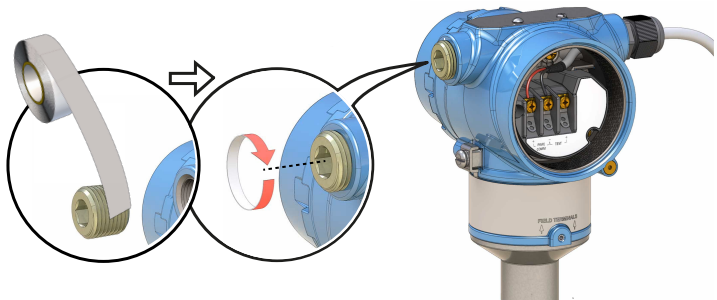

9. Attach and tighten the covers. Make sure the covers are fully engaged.
- Verify the cover jam screws are completely threaded into the housing.

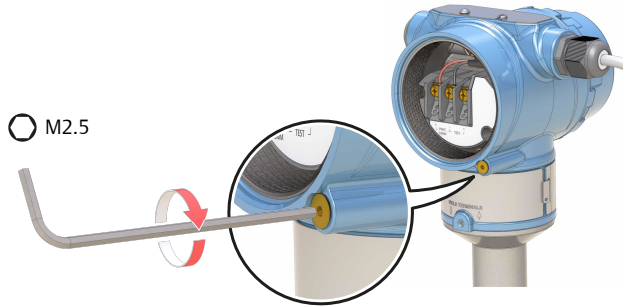

- Attach and tighten the covers. Make sure the covers are fully engaged.



10. ⚠ Required for explosion-proof/flameproof installations only: Both covers must be fully engaged to comply with explosion-proof requirements.
- Turn the cover jam screw counterclockwise until it contacts the cover.
 - Turn the jam screw an extra $\frac{1}{2}$ turn counterclockwise to secure the cover.
 - Verify that the covers cannot be removed.

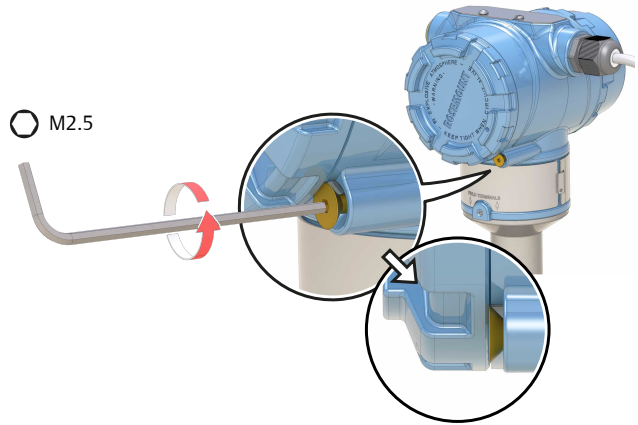

11. Connect the power supply.

5 Configuration

5.1 System readiness

5.1.1 Confirm correct device driver

- Verify that the correct Device Driver (DD) or Device Type Manager (DTM) is loaded on your systems to ensure proper communication.
- Download the latest DD/DTM at [Emerson.com/DeviceInstallKits](https://www.emerson.com/DeviceInstallKits).

5.1.2 Confirm HART® revision capability

If using HART-based control or asset management systems, confirm the HART capability of those systems prior to installation of the level detector. Not all systems are capable of communicating with HART Revision 7 protocol. A level detector can be configured for either HART Revision 5 or 7.

Switching HART revision with a generic menu

If the HART configuration tool is not capable of communicating with a HART Revision 7 device, it will load a generic menu with limited capability. To switch the HART revision mode from the generic menu:

Procedure

Locate the “Message” field.

- a) To switch to HART Revision 5, enter **HART5** and 27 spaces in the message field.
- b) To switch to HART Revision 7, enter **HART7** and 27 spaces in the message field.

Switching HART revision using AMS Device Manager

Prerequisites

AMS Device Manager versions 10.5 or greater are compatible with HART Revision 7.

To switch the HART revision mode from AMS Device Manager:

Procedure

1. Click on **Manual Setup**, and then select the **HART** tab.
2. Select **Change HART Revision** and then follow the on screen prompts.

Switching HART revision using a handheld communicator

To switch the HART revision mode from DD-based handheld communicator:

Procedure

1. From the Home screen, select **Configure**.
2. Select **Manual Setup** → **HART**.
3. Select **Communication Settings** → **Change HART Revision**.
4. Change the HART revision.

Switching HART revision using the LOI

To switch the HART revision mode using the LOI (Local Operator Interface):

Procedure

1. Press any LOI configuration button to activate the menu.
2. Scroll down (↓) and then select **EXTENDED MENU** (←↓).
3. Scroll down (↓) and then select **HART REV** (←↓).
4. To change HART revision, select **HART REV 5** (←↓), or scroll down (↓) and then select **HART REV 7** (←↓).
5. Exit the menu system by either waiting one minute for the **EXIT MENU?** prompt, or scrolling down menus to find and select **BACK TO MENU** and **EXIT MENU**.

5.2 Configure level detector using Guided Setup

The options available in the Guided Setup wizard include all items required for basic operation. All basic configuration parameters are described in the Rosemount 2140 [Reference Manual](#).

5.2.1 Configure using AMS Device Manager

Procedure

1. Start AMS Device Manager.
2. Select **View** → **Device Connection View**.
3. In the *Device Connection View*, double-click the HART modem icon.
4. Double-click the device icon.
5. Select **Configure** → **Guided Setup**.
6. Select **Basic Setup** and follow the on-screen instructions.

5.2.2 Configure using Field Communicator

Procedure

1. Turn on the Field Communicator and connect to the device.
2. Select **Configure** → **Guided Setup**.
3. Select **Basic Setup** and follow the on-screen instructions.

5.2.3 Configure using the LOI

The **Guided Setup** wizard is not available on the LOI (Local Operator Interface).



Emerson Automation Solutions

6021 Innovation Blvd.
Shakopee, MN 55379, USA

+1 800 999 9307 or +1 952 906 8888

+1 952 949 7001

RFQ.RMD-RCC@Emerson.com

Latin America Regional Office

Emerson Automation Solutions
1300 Concord Terrace, Suite 400
Sunrise, FL 33323, USA

+1 954 846 5030

+1 954 846 5121

RFQ.RMD-RCC@Emerson.com

Asia Pacific Regional Office

Emerson Automation Solutions
1 Pandan Crescent
Singapore 128461

+65 6777 8211

+65 6777 0947

Enquiries@AP.Emerson.com

[Linkedin.com/company/Emerson-Automation-Solutions](https://www.linkedin.com/company/Emerson-Automation-Solutions)

[Twitter.com/Rosemount_News](https://twitter.com/Rosemount_News)

[Facebook.com/Rosemount](https://www.facebook.com/Rosemount)

[Youtube.com/user/RosemountMeasurement](https://www.youtube.com/user/RosemountMeasurement)

North America Regional Office

Emerson Automation Solutions
8200 Market Blvd.

Chanhassen, MN 55317, USA

+1 800 999 9307 or +1 952 906 8888

+1 952 949 7001

RMT-NA.RCCRFQ@Emerson.com

Europe Regional Office

Emerson Automation Solutions Europe
GmbH

Neuhofstrasse 19a P.O. Box 1046

CH 6340 Baar

Switzerland

+41 (0) 41 768 6111

+41 (0) 41 768 6300

RFQ.RMD-RCC@Emerson.com

Middle East and Africa Regional Office

Emerson Automation Solutions

Emerson FZE P.O. Box 17033

Jebel Ali Free Zone - South 2

Dubai, United Arab Emirates

+971 4 8118100

+971 4 8865465

RFQ.RMTMEA@Emerson.com

©2020 Emerson. All rights reserved.

Emerson Terms and Conditions of Sale are available upon request. The Emerson logo is a trademark and service mark of Emerson Electric Co. Rosemount is a mark of one of the Emerson family of companies. All other marks are the property of their respective owners.