



#### DESCRIPTION

The RCT1000 Coriolis mass flow meter identifies flow rate by directly measuring mass flow and density of fluids over a wide range of process temperatures with a high degree of accuracy. For homogenous fluids consisting of two components like sugar and water, the RCT1000 Coriolis system can derive the concentration and mass of each component based on fluid properties and density measurement. Furthermore, the unobstructed, open flow design makes it suitable for a variety of fluids such as slurries and other viscous, nonconductive fluids that are difficult to measure with other technologies.

#### APPLICATIONS

The Coriolis design and measurement principle allows the meter to be an exceptional device in measuring:

- Oil and fuels
- Homogeneous suspensions and slurries
- Adhesives, glues or binding materials
- Coatings and hardeners
- Dyes, fragrances, vitamins and other additives
- Vegetable oils and fats

#### OPERATION

Coriolis flow meters simultaneously measure mass flow rate, density and temperature. As fluid flows through the vibrating sensor tube, forces induced by the flow cause the tube to twist slightly. These small deflections are measured by carefully placed detectors. A phase shift occurs between detector signals that is directly proportional to mass flow rate. As the fluid density varies, the resonant frequency at which the tube vibrates changes, which is also measured by the detectors. These larger sensors have two tubes that are vibrated in opposing directions in order to reduce the effect of process vibration on the flow measurement. Temperature is measured by an internal RTD in order to calculate thermal effects on the tube vibrating frequency and can be used as a measurement output.

#### CONTROLS SYSTEM INTEGRATION

RCT1000 transmitters provide a variety of means to integrate the meter's output into new and existing operations. The batch and PID functionality enables direct control of devices, such as valves, by use of digital or analog outputs. Additionally, programmable digital outputs can indicate low and high alarm conditions. Network options are available including EtherNet/IP, Modbus TCP/IP and Modbus RTU.



#### MAINTENANCE

With no internal moving parts, the vibrating tube design has little impact on mechanical wear, resulting in a longer life expectancy and in fewer repairs than many other flow technologies.

#### FLUID DIAGNOSTICS

RCT Console software offers much more than configuration features. Users can obtain advanced data logging and performance trending analysis, as well as system verification provided by the unique HealthTrack feature, which captures critical operation parameters.

#### ADVANTAGES

- Highly accurate direct measurement of:
  - ◊ Mass flow
  - ◊ Density
- Derive concentration of homogenous liquids containing two components
- Open flow path
- No straight-run requirements
- Low maintenance operation
- Flexible integration options
- Advanced fluid diagnostic software



## SPECIFICATIONS

The complete remote mount metering system consists of the following; each component must be purchased separately:

- Sensor
- Transmitter
- Cable assembly

### System Specifications

<b>Uncertainty</b>	Mass Flow Rate (Liquids)	RCS018, RCS025, RCS050 (option 2)	±0.2% of reading ±0.05% of full scale	
		RCS100, RCS200, RCS300 (option 1)	±0.1% of reading ±0.025% of full scale	
		RCS018...300 (option 6)	±0.1% of reading*	
<b>Density</b>	RCS018, RCS025, RCS050	±0.12486 lb/ft <sup>3</sup> (0.002 g/cm <sup>3</sup> )		
	RCS100, RCS200, RCS300	±0.03121 lb/ft <sup>3</sup> (0.0005 g/cm <sup>3</sup> )		
<b>Repeatability</b>	RCS018, RCS025, RCS050, RCS100, RCS200, RCS300	±0.05% of reading ± zero stability		
<b>Zero Stability</b>	RCS018, RCS025, RCS050	±0.05% of full scale		
	RCS100, RCS200, RCS300 (option 1)	±0.025% of full scale		
	RCS100 (option 6)	±0.123 lb/min (3.35 kg/hr)		
	RCS200 (option 6)	±0.360 lb/min (9.79 kg/hr)		
	RCS300 (option 6)	±0.356 lb/min (9.68 kg/hr)		
<b>Safety Certifications</b>	Ordinary Location	Remote mount	CAN/CSA C22.2 No. 61010-1-12	
		Integral mount	CI I, Zn 1 AEx/Ex db ia IIB T4 Gb Explosion-proof for CI I Div 1 Grp CD with Intrinsically Safe Sensor for CI I Div 1 Grp CD	
		Remote transmitter	CI I, Zn 1 AEx/Ex db [ia Ga] IIB T6...T3 Gb Explosion-proof for CI I Div 1 Grp CD	
		Remote sensor	CI I, Zn 0 AEx/Ex ia IIB T6...T3 Ga Intrinsically Safe for CI I Div 1 Grp CD	
	cCSAus	Integral mount	II 2 G Ex db ia IIB T4 Gb	
		Remote transmitter	II 2 (1) G Ex db [ia Ga] IIB T6...T3 Gb	
		Remote sensor	II 1 G Ex ia IIB T6...T3 Ga	
		ATEX / IECEx		
<b>Density Measurement</b>	Flowing, referenced, API, Brix, Baume and net oil			

\* When flow rate is less than zero stability (lb/min) \* 1000, accuracy = zero stability / flow rate.

### Flow Rate Specifications

Model	Nominal Line and Equivalent Pipe Size	Number of Flow Tubes	Flow Range		Volumetric Equivalent 1g/cm <sup>3</sup>	
			lb/min	kg/hr	gal/min	l/h
RCS018	1/2 in., 3/16 in.	2	0...20	0...544	2.4	544
RCS025	1/2 in., 1/4 in.	2	0...40	0...1088	4.8	1088
RCS050	1/2 in., 1/2 in.	2	0...220	0...5987	26	5987
RCS100	1 in.	2	0...1000	0...27,216	120	27,716
RCS200	2 in.	2	0...1700	0...46,266	204	46,266
RCS300	3 in.	2	0...5200	0...141,520	623	141,520



### Sensor Specifications

	Model	Maximum Allowable Pressure (by Connection Type)				
		NPT	Class 150 Flange	Class 300 Flange	DN PN40	Tri-Clamp
<b>Pressure</b>	RCS018	3450 psi (238 bar)	275 psi (19 bar)	720 psi (49.6 bar)	40 bar (580 psi)	200 psi (14 bar)
	RCS025	3450 psi (238 bar)	275 psi (19 bar)	720 psi (49.6 bar)	40 bar (580 psi)	200 psi (14 bar)
	RCS050	3320 psi (229 bar)	275 psi (19 bar)	720 psi (49.6 bar)	40 bar (580 psi)	200 psi (14 bar)
	RCS100	2150 psi (148 bar)	275 psi (19 bar)	720 psi (49.6 bar)	40 bar (580 psi)	200 psi (14 bar)
	RCS200	2200 psi (152 bar)	275 psi (19 bar)	720 psi (49.6 bar)	40 bar (580 psi)	200 psi (14 bar)
	RCS300	—	275 psi (19 bar)	720 psi (49.6 bar)	40 bar (580 psi)	200 psi (14 bar)
<b>Wetted Materials</b>	<b>Standard</b>	316L stainless steel				
<b>Temperature</b>	<b>Fluid Range</b>	General Safety: -40...392° F (-40...200° C) Hazardous Location Sensor with Integral Mount Transmitter: -4...140° F (-20...60° C) Hazardous Location Sensor with Remote Mount Transmitter: -4...359° F (-20...182° C) as follows:				
		TEMP CODE		FLUID TEMP (MAX)		
		T6 (85° C)	67° C			
		T5 (100° C)	82° C			
	<b>Accuracy</b>	±1.8° F (1° C)				
	<b>Repeatability</b>	±0.54° F (0.3° C)				
<b>Process Connections</b>	NPT (RCS018...200), Class 150 Flange, Class 300 Flange, DN PN40, Tri-Clamp					
<b>Conformance</b>	NACE MR0175/ISO 15156					
<b>Pressure Standards/Approvals</b>	Canadian Registration Number (CRN); ATEX and general area sensors: PED 2014/68/EU, Group 1, Category II, Module D1 for line sizes 2 in. (60.3mm) and up, and Sound Engineering Practice (SEP) for other sizes					

## Transmitters

Feature	Model		
	RCTN	RCTX	RCTX with Display
Enclosure	NEMA 4 (IP65); powder coated aluminum, polycarbonate, urethane and stainless steel	NEMA 4X (IP66); powder coated aluminum, polycarbonate, urethane and stainless steel without glass window	NEMA 4X (IP66); powder coated aluminum, polycarbonate, urethane and stainless steel with glass window
Power Requirements	115/230V AC; $\pm 15\%$ 50/60 Hz 25W maximum 20...28V DC; 15W maximum	— 18...28V DC; 15W maximum	—
Ambient Temperature	14...158° F (–10...70° C)	– 4...140° F (–20...60° C)	– 4...140° F (–20...60° C)
Configuration	Four-button HMI or RCT Console configuration	RCT Console configuration	Four-Optical button HMI or RCT Console configuration
Display	4 line $\times$ 20 character; alpha-numeric; dot matrix; LED backlighting	—	4 line $\times$ 20 character; alpha-numeric; dot matrix; LED backlighting
RTD Input	Standard (1 input)	Built-in 100 Ohm Platinum RTD within the sensor body	
	Optional (1 auxiliary input)	Additional 100 Ohm 3-wire Platinum RTD input for the secondary RTD is used by customers who want to be able to calibrate their RTD	—
Analog I/O	Outputs	Three 4...20 mA (0...22 mA capable), maximum load 500 Ohms, approximately 16 bit resolution outputs; assignable to mass flow, volume, density, temperature, concentration, PID and similar measurements. User defined fault condition output value anywhere in the 0...22 mA range	Two (three with HART Option) 4...20 mA (0...22 mA capable), maximum load 500 Ohms, approximately 16 bit resolution outputs; assignable to mass flow, volume, density, temperature, concentration, PID and similar measurements. User defined fault condition output value anywhere in the 0...22 mA range
	Inputs	Two 0...5V DC inputs. 20k Ohms input impedance, approximately 12 bit resolution	One 0...5V DC input. 20k Ohms input impedance, approximately 12 bit resolution
Auxiliary Power	Internal 24V DC supply, 100 mA max. (for batching functions, frequency output channel and like applications)	—	—
Frequency/Pulse Output	One open collector transistor, user configurable as rate (3 kHz max output), accumulator 0...10 Hz; PWM with 1 kHz, 5...28V DC carrier. User assignable to rate, any totalizer, PID, temperature, density, concentration or other similar measurements		
Digital I/O	Outputs	Four 5...28V DC, 50 mA maximum current draw (external pullup resistor required)	Two 5...28V DC, 50 mA maximum current draw (external pullup resistor required)
	Inputs	Four 5...24V DC, 1k Ohms impedance	Three 5...24V DC, 1k Ohm impedance
Industrial Communications Modular Port	Standard	Modbus RTU (EIA-485/RS485)	
	Optional Module	Modbus TCP/IP & EtherNet/IP	
	Optional Module	—	HART 7
Standard Configuration Port	USB 2.0 interface (through a Mini-B receptacle) for RCT Console software		
Alarms	Six Hi/Lo Alarms; Alarm status on display by default, assignable to digital Output 2 or 4 and available via digital communications	Six Hi/Lo Alarms; Alarm status on display by default, assignable to digital Output 2 and available via digital communications	
Transmission Distance	Up to 100 ft (30 meters); contact factory if longer length is needed		
Measurements	Forward and reverse mass flow and total, density, temperature; concentration, volumetric flow and total (derived)		
Other Functions	Batch control, PID control. User configuration of all I/O functions		

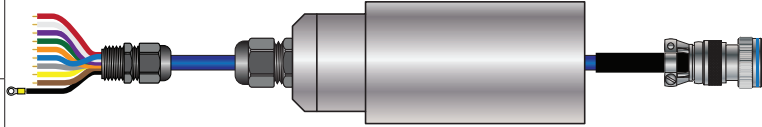
## CABLE KITS

The kits include the cable assembly, cable protector and sensor cable connection cover.			
RC820476-XX	Kit, PVC jacketed cable XX=length in ft; 20, 35, 50, 70, 100	Temp range: –40...176° F (–40...80° C)	 <p>General Safety Kit</p>
RC820477-XX	Kit, FEP jacketed cable XX=length in ft; 20, 35, 50, 70, 100	Temp range: –94...392° F (–70...200° C)	
RC830054-XX	TFE jacketed cable XX=length in ft; 20, 35, 50, 70, 100	Temp range: –4...140° F (–20...60° C)	
			 <p>Hazardous Location Cable</p>

## DIMENSIONS

### RCTX Transmitter, Integral Mount Electronics Enclosure Dimensions

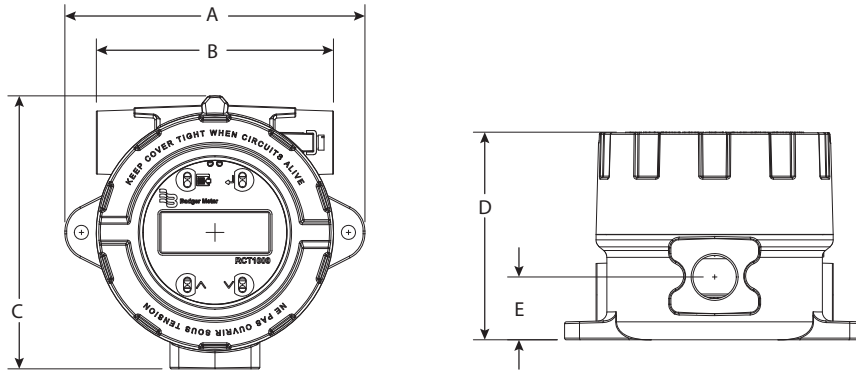

A	B	C	D	E
6.57 in. (167 mm)	5.20 in. (132 mm)	5.98 in. (152 mm)	4.57 in. ± 0.12 in. (116 mm ± 3 mm)	1.37 in. (35 mm)

### RCTX Transmitter, Remote Mount Electronics Enclosure Dimensions

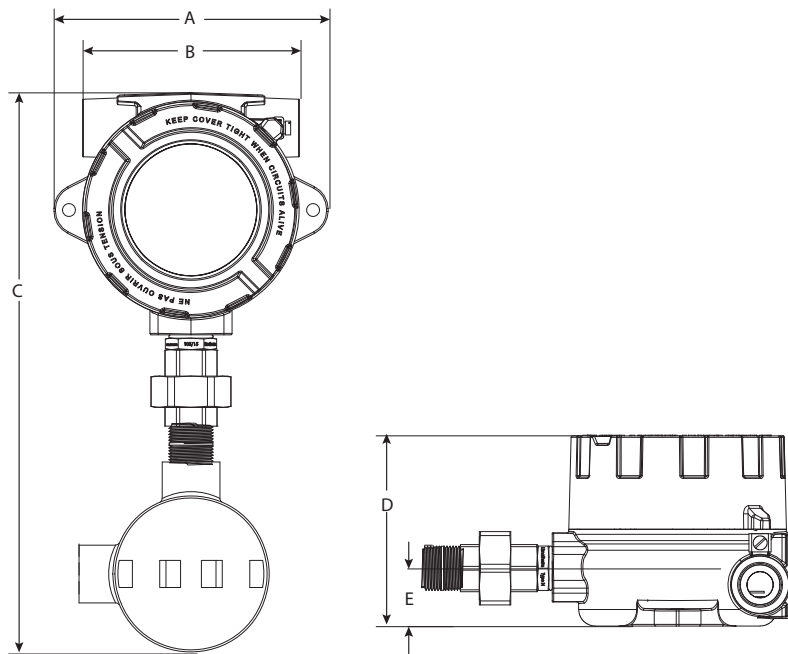

A	B	C	D	E
6.57 in. (167 mm)	5.20 in. (132 mm)	13.43 in. (341 mm)	4.57 in. ± 0.12 in. (116 mm ± 3 mm)	1.37 in. (35 mm)

### RCTN Transmitter Electronics Enclosure Dimensions

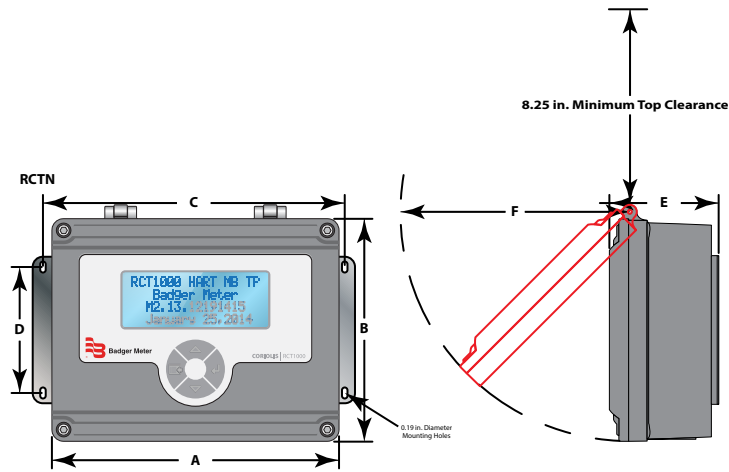

A	B	C	D	E	F
9.80 in. (249.9 mm)	8.00 in. (203.2 mm)	10.30 in. (261.6 mm)	4.30 in. (109.2 mm)	3.66 in. (93.0 mm)	8.32 in. (211.2 mm)

### RCTN Transmitter, Pipe Mounting Options

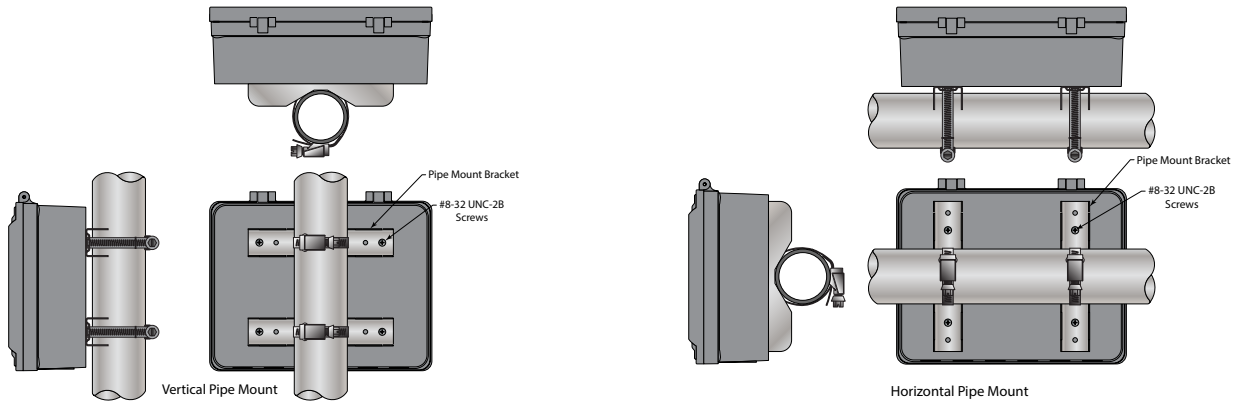

### RCTN Transmitter Only, Pipe Bracket Dimensions

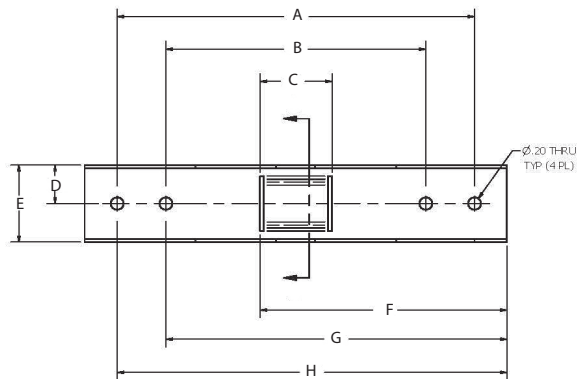

A	B	C	D	E	F	G	H
5.50 in. (139.7 mm)	4.00 in. (101.6 mm)	1.11 in. (28.2 mm)	0.625 in. (15.9 mm)	1.25 in. (31.8 mm)	3.80 in. (96.5 mm)	5.25 in. (133.6 mm)	6.00 in. (152.4 mm)

**Sensor Dimensions, RCS018...RCS300**

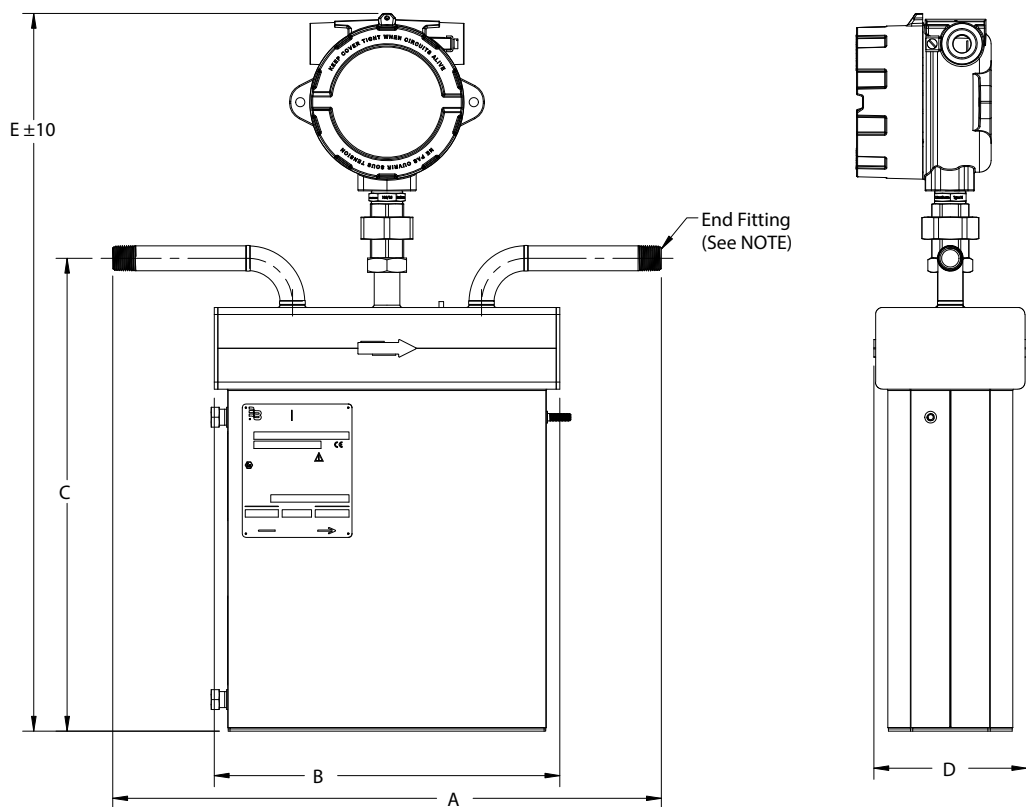

Figure 1: Large sensor dimensions

Sensor	Nominal Size	A <sup>1</sup>	B	C	D	E (Standard)	E (Remote)
RCS018	1/2 in.	13.6 in. (346 mm) <sup>1</sup>	7.1 in. (180 mm) <sup>1</sup>	8.5 in. (217 mm) <sup>2</sup>	4.4 in. (113 mm) <sup>2</sup>	19.3 in. (489 mm)	18.3 in. (464 mm)
RCS025	1/2 in.	16.0 in. (406 mm) <sup>1</sup>	9.0 in. (228 mm) <sup>1</sup>	9.9 in. (253 mm) <sup>2</sup>	4.4 in. (113 mm) <sup>2</sup>	20.7 in. (525 mm)	19.7 in. (500 mm)
RCS050	1/2 in.	18.5 in. (470 mm) <sup>1</sup>	11.6 in. (296 mm) <sup>1</sup>	15.9 in. (405 mm) <sup>2</sup>	5.1 in. (131 mm) <sup>2</sup>	24.2 in. (615 mm)	23.2 in. (590 mm)
RCS100	1 in.	23.2 in. (590 mm) <sup>1</sup>	16.8 in. (426 mm) <sup>1</sup>	27.6 in. (700 mm) <sup>2</sup>	6.4 in. (163 mm) <sup>2</sup>	34.3 in. (870 mm)	33.3 in. (845 mm)
RCS200	2 in.	26.4 in. (670 mm) <sup>2</sup>	18.5 in. (472 mm) <sup>2</sup>	28.6 in. (726 mm) <sup>3</sup>	7.9 in. (203 mm) <sup>3</sup>	33.4 in. (848 mm)	32.4 in. (823 mm)
RCS300	3 in.	40.9 in. (1040 mm) <sup>2</sup>	28.7 in. (728 mm) <sup>2</sup>	40.4 in. (1028 mm) <sup>3</sup>	9.5 in. (243 mm) <sup>3</sup>	45.3 in. (1150 mm)	44.3 in. (1125 mm)

<sup>1</sup> ± 0.12 in (3 mm)

<sup>2</sup> ± 0.15 in (4 mm)

<sup>3</sup> ± 0.24 in (6 mm)

**NOTE:** End fittings can be NPT (shown), Class 150 or Class 300 ANSI flanges, or other; dimensions A and C do not change.

**APPROXIMATE SHIPPING WEIGHTS**

Sensor Only			Transmitter Only			Cables Only		
RCS018	15 lb	6.8 kg	RCTN	6.4 lb	2.9 kg	RC820***-20	6 lb	2.7 kg
RCS025	16 lb	7.3 kg	RCTX	3.4 lb	1.8 kg	RC820***-35	8 lb	3.6 kg
RCS050	26 lb	11.8 kg	RCTX-K Integral	4.9 lb	2.2 kg	RC820***-50	10 lb	4.5 kg
RCS100	47 lb	21.3 kg	RCTX-K Remote	8.2 lb	3.7 kg	RC820***-70	13 lb	5.9 kg
RCS200	90 lb	40.8 kg				RC820***-100	17 lb	7.7 kg
RCS300	219 lb	99.3 kg						

## NETWORK OPTIONS

<b>RS-485 Network</b>	All RCT1000 meters come equipped an EIA-485 port with Modbus RTU
<b>Ethernet</b>	An optional Ethernet module allows communications via Modbus TCP/IP or EtherNet/IP
<b>HART</b>	An optional HART module, integral mount transmitter

## SOFTWARE UTILITY

RCT Console software is a PC-based software that can be used to configure, operate and diagnose the RCT1000 Coriolis meter. Additionally, the software can log and graph fluid characteristics and parameters for historical comparisons. RCT Console software is included with the RCT1000 Coriolis meter.

Sample	Time [s]	33. Phase $\mu$ s	60. Tube Frequency Hz	183. Coil A Voltage mV	184. Driver Output %	185. Coil B Voltage mV
1	0.359	-0.01832175068572624	88.507232666015625	60.0019416809082	69.021713256835937	59.978321075439453
2	1.045	0.0089603438973426819	88.516281127929688	59.999141693115234	69.029747009277344	59.97698974609375
3	2.075	0.044337108731269836	88.521278381347656	60.00080108642578	69.03057861328125	59.9730110168457
4	3.105	-0.059853188693523407	88.511688232421875	60.00830474853516	69.027748107910156	59.9715690612793
5	4.134	0.021695289760828018	88.5118637084961	59.991420745849609	69.026771545410156	59.9692874145078
6	5.164	0.0735641223182215	88.512863159179808	59.99433889257813	69.041763305664063	59.96792640087891
7	6.193	0.029611240228010582	88.505957260742187	59.99884032203126	69.036247253417969	59.965488877929688
8	7.223	0.066253632307052612	88.5107727095078125	59.999370574951172	69.035362243652344	59.967361450195313
9	8.253	0.061536488367786407	88.491180419921875	59.990581512451172	69.03958892222656	59.96754074029663
10	9.282	-0.1050340011715889	88.511962890625	59.99462890625	69.03406693359375	59.963081359863281
11	10.312	-0.015941370278596878	88.50128173828125	60.005199432373047	69.028480629785156	59.986789703369141
12	11.341	-0.0635964497923851	88.497077941894531	60.016311645507813	69.017707824707031	59.9633903503418
13	12.371	-0.00823190638422966	88.506942749023438	59.997470855712891	69.030845642089844	59.971458435058984
14	13.167	0.11063340306282043	88.502738952636719	60.005691528320312	69.027137756347656	59.976848602294922
15	14.196	0.023042159150011177	88.499702453613281	59.993961334228516	69.033676147460938	59.969009399414063
16	15.226	-0.057191379360305206	88.505988899484375	60.004070281862422	69.027626037597656	59.978610952437941
17	16.256	0.020765749514102936	88.512100218728563	59.993301391601563	69.03858349609375	59.983150442177734
18	17.285	0.086112096905708313	88.518013000482821	59.964481811523438	69.04222868730469	59.971881866455078
19	18.315	-0.10414709895849228	88.51618194900781	59.997970581054687	69.034095764160156	59.97020019531125
20	19.344	-0.034287728369235992	88.5077896118164	59.990089416503906	69.038200378417969	59.971920013427734
21	20.031	0.032753609120845795	88.5064697265625	59.99407958984375	69.03958892222656	59.980728149414063
22	21.060	0.0646323710680008	88.501480102530662	59.99655153671875	69.027915954589844	59.966129302978516
23	22.090	0.000642613391391933	88.503471374511719	60.015239715576172	69.015988840332031	59.985890987548828

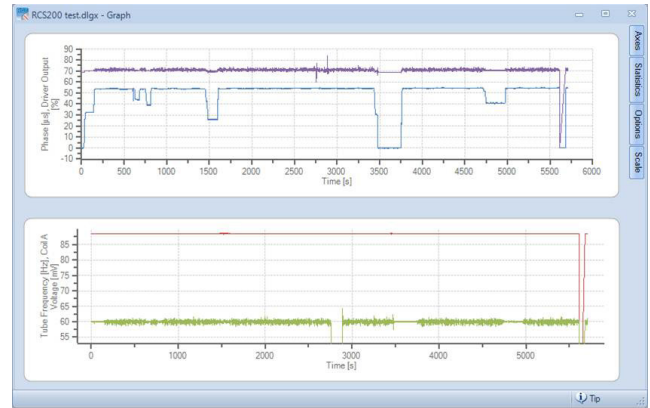

## ACCESSORIES

Please consult the factory for the availability, pricing and delivery estimates of additional accessories.

**PART NUMBER CONSTRUCTION**

**Sensor Part Number (Remote Mount Transmitter Option)**

		<div style="display: flex; justify-content: space-around; align-items: center;"> <div style="border: 1px solid black; padding: 2px;"> </div> <div style="border: 1px solid black; padding: 2px;"> </div> <span>-</span> <div style="border: 1px solid black; padding: 2px;"> </div> <span>-</span> <div style="border: 1px solid black; padding: 2px;"> </div> <span>-</span> <div style="border: 1px solid black; padding: 2px;"> </div> <span>-</span> <div style="border: 1px solid black; padding: 2px;"> </div> <div style="border: 1px solid black; padding: 2px;"> </div> <span>-</span> <div style="border: 1px solid black; padding: 2px;"> </div> </div>					
<b>Model</b>							
Badger Meter Coriolis Flow Meter		RCS					
<b>Nominal Line and Equivalent Pipe Size</b>							
1/2 in., 3/16 in. (4.76 mm)		018					
1/2 in., 1/4 in. (6.35 mm)		025					
1/2 in., 1/2 in. (12.70 mm)		050					
1 in., 1 in. (25.40 mm)		100					
2 in., 2 in. (50.80 mm)		200					
3 in., 3 in. (76.20 mm)		300					
<b>Wetted Material</b>							
316L Stainless Steel		S					
<b>Process Connection Type</b>							
NPT (018...200 sensors only)		NPT					
Class 150 ASME B16.5 Flange (018...300 sensors only)		FAA					
Class 300 ASME B16.5 Flange (018...300 sensors only)		FAB					
PN40 Flange		PNB					
Tri-clamp		TRI					
<b>Electronic Mounting Options</b>							
Remote Mount Transmitter		R					
<b>Certifications</b>							
General/Ordinary Area, CE		G					
cCSAus Class I, Div 1; Class I, Zone 0		H					
ATEX I.S. Zone 0 sensor, CE IECEx I.S.		A					
Zone 0 sensor		C					
<b>Calibration/Meter Uncertainty</b>							
<b>Liquids</b>							
Mass Flow: 0.1% of reading ± 0.025% of full scale (100, 200, 300 sensors only)		1					
Mass Flow: 0.2% of reading ± 0.05% of full scale (018...050 sensors only)		2					
Mass Flow: 0.1% of reading		6					
<b>Pressure Registration</b>							
CRN for Canada (Process connection types NPT, FAA, FAB only)		C					
None		N					

\*Other process connection types can be provided. Consult factory for pricing and delivery estimates.

**General Safety Transmitter Part Number (Remote Mount)**

		<div style="display: flex; justify-content: space-around; align-items: center;"> <div style="border: 1px solid black; padding: 2px;">RCT</div> <div style="border: 1px solid black; padding: 2px;">N</div> <span>-</span> <div style="border: 1px solid black; padding: 2px;">K</div> <span>-</span> <div style="border: 1px solid black; padding: 2px;">D2</div> <div style="border: 1px solid black; padding: 2px;">R</div> <span>-</span> <div style="border: 1px solid black; padding: 2px;"> </div> <span>-</span> <div style="border: 1px solid black; padding: 2px;"> </div> </div>					
<b>Communication Protocol</b>							
Modbus RTU & Ethernet (Modbus TCP/IP, EtherNet/IP)		E					
Modbus RTU (Standard on all models)		M					
<b>Sensor Connection</b>							
Ordinary Areas (RCTN only)		N					



**Hazardous Location Transmitter Part Number (Remote Mount)**

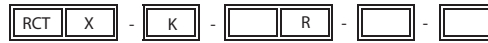

Certifications	
cCSAus Class I, Div 1; Class I Zone 1	H1
ATEX I.S. Zone 1 *	A1
IECEX I.S. Zone 1 *	C1
Communication Protocol	
Modbus RTU & Ethernet (Modbus TCP/IP, EtherNet/IP)	E
Modbus RTU (Standard on all models)	M
Modbus RTU & HART	H
Sensor Connection	
Hazardous location (RCTX only)	B

**Integral Mount Transmitter with Sensor Part Number Construction**



Model	RCS								
Nominal Line Size and Flow Rate									
1/2 Inch / DN15   20 lb/min	018								
1/2 Inch / DN15   40 lb/min	025								
1/2 Inch / DN15   220 lb/min	050								
1 Inch / DN25   1000 lb/min	100								
2 Inch / DN50   1700 lb/min	200								
3 Inch / DN80   5200 lb/min	300								
Wetted Material		S							
Process Connection Type *									
National Pipe Thread (018...200 sensors)			NPT						
Class 150 ASME 16.5 Flange (018...300 sensors)			FAA						
Class 300 ASME 16.5 Flange (018...300 sensors)			FAB						
PN40 Flange			PNB						
Tri-clamp			TRI						
Electronic Mounting Options									
Integral Mount Transmitter (with RCTX only)					M				
Certifications									
cCSAus Class I, Div 1; Class I, Zone 1								H	
ATEX I.S. Zone 1, CE								A	
IECEX I.S. Zone 1								C	
Calibration/Meter Uncertainty									
Liquids									
(018...050 sensors) Mass Flow: 0.2% of reading ± 0.05% of full scale									2
(100...300 sensors) Mass Flow: 0.1% of reading ± 0.025% of full scale									1
Mass Flow: 0.1% of reading									6
Pressure Registration									
CRN for Canada (Process connection types NPT, FAA, FAB only)									C
None									N
Display									
Explosion Proof Transmitter, Display / Keypad									XK
Explosion Proof Transmitter, No Display / Keypad									XN
Communication									
Modbus RTU & Ethernet (Modbus TCP/IP, EtherNet/IP)									E
Modbus RTU (Standard on all models)									M
Modbus RTU and HART									H

\*Other process connection types can be provided. Consult factory for pricing and delivery estimates.

**INTENTIONAL BLANK PAGE**

**INTENTIONAL BLANK PAGE**

## Control. Manage. Optimize.

Trademarks appearing in this document are the property of their respective entities. Due to continuous research, product improvements and enhancements, Badger Meter reserves the right to change product or system specifications without notice, except to the extent an outstanding contractual obligation exists. © 2018 Badger Meter, Inc. All rights reserved.

**[www.badgermeter.com](http://www.badgermeter.com)**

---

The Americas | Badger Meter | 4545 West Brown Deer Rd | PO Box 245036 | Milwaukee, WI 53224-9536 | 800-876-3837 | 414-355-0400  
México | Badger Meter de las Americas, S.A. de C.V. | Pedro Luis Ogazón N°32 | Esq. Angelina N°24 | Colonia Guadalupe Inn | CP 01050 | México, DF | México | +52-55-5662-0882  
Europe, Eastern Europe Branch Office (for Poland, Latvia, Lithuania, Estonia, Ukraine, Belarus) | Badger Meter Europe | ul. Korfantego 6 | 44-193 Knurów | Poland | +48-32-236-8787  
Europe, Middle East and Africa | Badger Meter Europa GmbH | Nurtinger Str 76 | 72639 Neuffen | Germany | +49-7025-9208-0  
Europe, Middle East Branch Office | Badger Meter Europe | PO Box 341442 | Dubai Silicon Oasis, Head Quarter Building, Wing C, Office #C209 | Dubai / UAE | +971-4-371 2503  
Slovakia | Badger Meter Slovakia s.r.o. | Racianska 109/B | 831 02 Bratislava, Slovakia | +421-2-44 63 83 01  
Asia Pacific | Badger Meter | 80 Marine Parade Rd | 21-06 Parkway Parade | Singapore 449269 | +65-63464836  
China | Badger Meter | 7-1202 | 99 Hangzhong Road | Minhang District | Shanghai | China 201101 | +86-21-5763 5412  
Switzerland | Badger Meter Swiss AG | Mittelholzerstrasse 8 | 3006 Bern | Switzerland | +41-31-932 01 11