

80 GHz LEVEL RADAR

OPERATING INSTRUCTIONS



Table of Contents

1. Products introduction	3
1.1 Features	3
1.2 LM78xx series selection guide	3
2. Technical specifications	4
3. Install	5
4. Dimensions	6
5. Wiring	7
5.1 4-wire product	7
5.2 2-wire product	7
6. Local operation	8
6.1 Interface Description	8
6.2 Instructions for measurement interface	8
6.3 Instructions for Echo interface	9
6.4 Instructions for Setup interface	9
6.5 Menu options	10
6.5.1 Basic	11
6.5.2 Display	16
6.5.3 Diagnostics	17
6.5.4 Advanced	18
6.5.5 Information	27
6.6 Keyboard input method	28
7. Menu tree	30
7.5.1 First-level menu tree	30
7.5.2 Secondary menu tree-basic settings	30
7.5.3 Secondary menu tree-display	31
7.5.4 Secondary menu tree-diagnostics	31
7.5.5 Secondary menu tree-Advanced	32
7.5.6 Secondary menu tree-information	33
8. Error Code	33
9. Glossary	34

1. Products | introduction

1.1 Features

The series is radar operating at 80 GHz, which has a maximum measuring range of 10m and a minimum blind zone of 8cm. Higher operating frequency and shorter wavelength make it ideal for solid applications, including those with extreme dust and high temperature to + 200° C. The radar consists of an electronic circuit coupled to a lens antenna and flange for quick and easy positioning.

The main benefits of using 80 GHz over devices using lower frequency are:

- ✔ Based on the self-developed CMOS millimeter wave RF chip, a more compact RF architecture, a higher signal-to-noise ratio, and a smaller blind zone are realized.
- ✔ 5GHz working bandwidth means higher measurement resolution and accuracy.
- ✔ 3° antenna beam angle, so the interference in the environment has less impact on the instrument, and the installation is more convenient.
- ✔ Shorter wavelength yields good reflection properties on sloped solids, so aiming towards material angle of repose is usually not necessary.
- ✔ Support remote debugging and remote upgrading to reduce the cost of field personnel.

2. Technical specifications

Table1 Technical Specifications

Frequency	80GHz 5GHz FMCW bandwidth
Measuring range	0.3 m ~ 10m
Measurement accuracy	±1mm
Beam angle	3° 8°
Minimum measured dielectric	≥2
Power	15~28VDC
Communication	MODBUS HART/
Signal output	4 ~ 20mA
Fault output	3.8mA, 4mA, 20mA, 21mA, hold
Field operation / programming	128 × 64 dot matrix display / 4 buttons PC software Bluetooth
humidity	≤৯৫%ভে
Enclosure	Aluminum alloy, stainless steel
Antenna type	Lens antenna/anti-corrosive antenna / flange isolated by quartz
Process temperature	T0:-40~৫ ; T1:-40~200 ; T2:-40~500 ; T3:-40~1000
Process pressure	-0.1~2MPa
Product Size	Ø100*270mm
Cable entry	M20*1.5
Recommended cables	AWG18 or 0.75mm ²
Protection class	IP67
Explosion-proof grade	ExdiaIICT6
Installation method	Thread or flange
Weight	2.480Kg/2.995Kg
Packing box size	370*270*180mm

3. Installation

- ⊙ Keep the antenna beam free of any interference such as ladders, pipes, steps

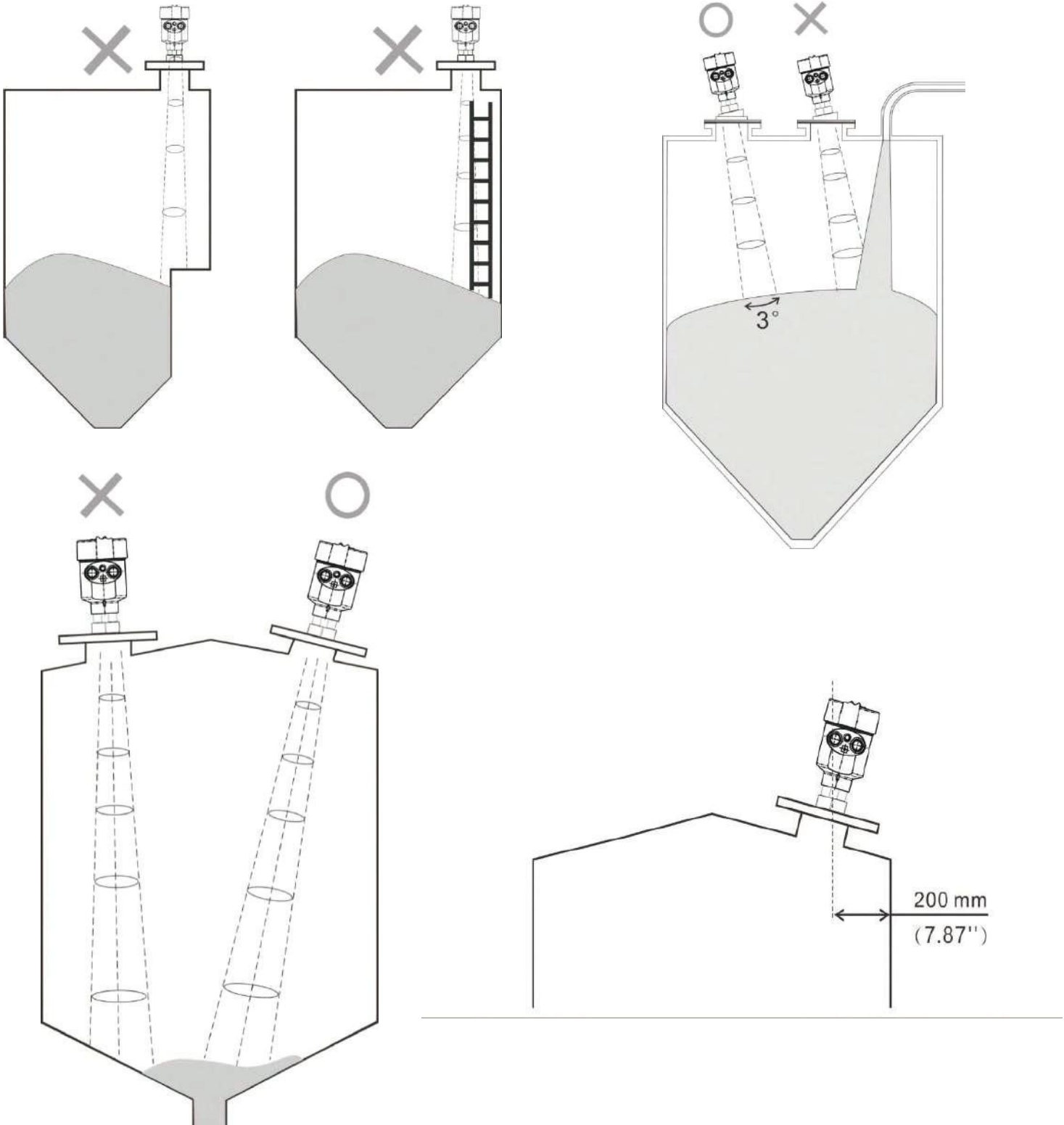

4. Dimensions

3° Beamwidth

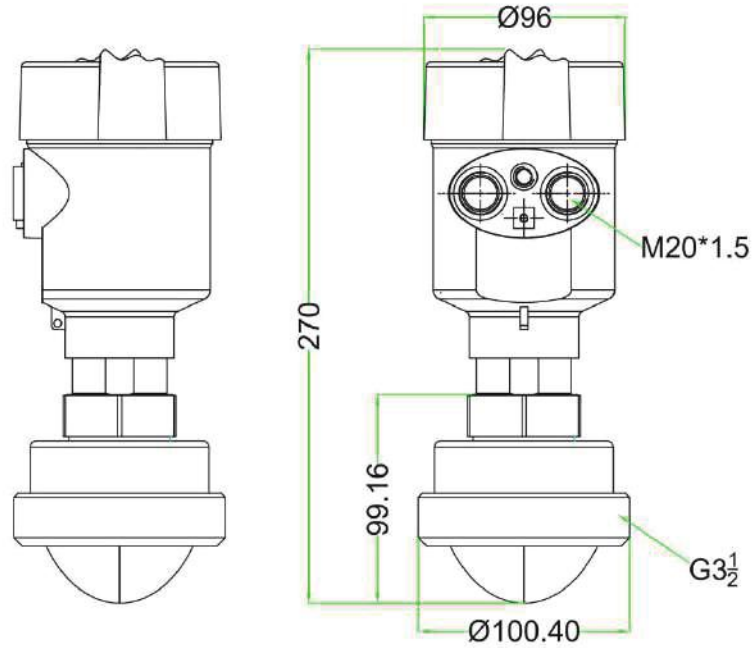

8° Beamwidth

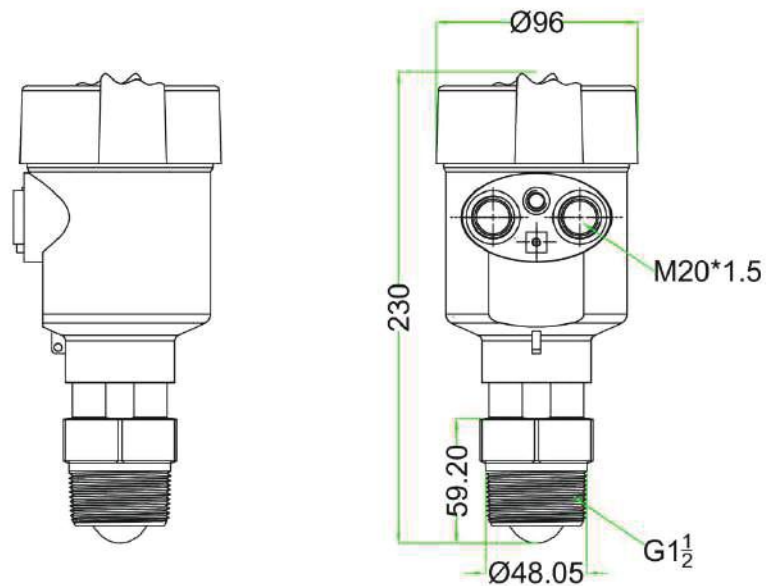

Fig.5 Dimensions for LM78xx series

5. Wiring

2-wire product



5.1 RS485 Modbus

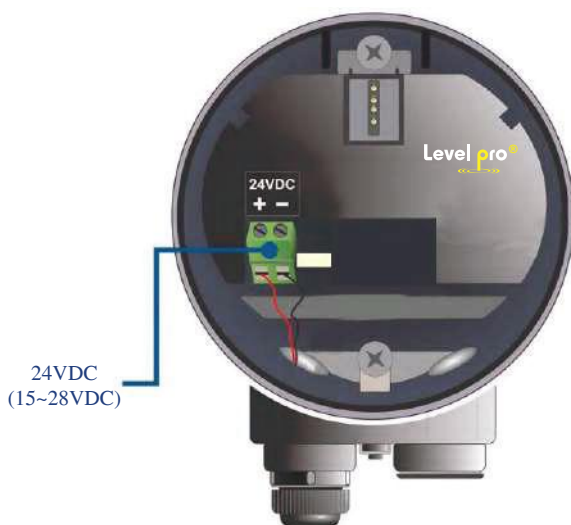

4-20mA output

RS 485

Fig.7 Wiring Diagram

6. Local operation

The ProScan2 carries out its level measurement tasks according to customer settings, which can be modified locally via the Local Display Module (LDM).

6.1 Interface Description

LDM has 5 Separate display interfaces:

[**Measurement Interface**]: Display system running status and current measurement result.

[**Echo Interface**]: Display the real-time measured echo curve and Time-Vary Threshold (TVT).

[**History Interface**]: Display historical measurement data recorded by the radar. [**Setup**

Interface]: Set various system parameters.

[**Input Interface**]: Take the task of input.

The functions of the 4 keys are different in different display interface.

6.2 Instructions for measurement interface

Measurement Interface is shown below:



Measurement Interface overview
Key Function in Measurement Interface

Keyboard	Features
ESC	-Switch to echo interface
UP	-NULL
DN	-NULL
ENT	-Switch to Setup Interface

6.3 Instructions for Echo interface

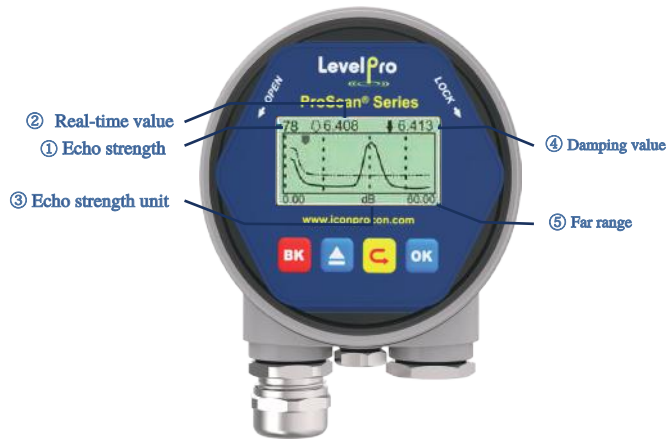

Echo Interface overview

Key function in Echo Interface

keyboard	Features
ESC	-Switch to Measurement Interface
UP	-No use
DN	-Show / hide TWT curve
ENT	-NULL

In **Measurement Interface**, press [ESC] key to enter the **Echo Interface**.

6.4 Instructions for Setup interface

- Press [ENT] to switch from the **Measurement Interface** to the **Setup Interface**, as shown in the figure below:



Setup interface overview Table4 keys
function in Setup interface

keyboard	Features
ESC	-Switch to Measurement Interface/Exit
UP	-Move up
DN	-Move down
ENT	-Enter

6.4.1 [Basic]

[Basic] Menu contains the necessary functions for quick start of the level meter, as shown in the following table. The options list is shown in the table below:

Menu Item for Basic

Default	Menu Item
•	Vessel type
	Material Type / Dielectric Constant
	Low calibration point
	High calibration point
	Damping
	Sensor mode

6.4.2 [Display]

[Display] Menu contains the necessary functions for setting the system unit. The option list is shown in the following table:

Menu Item for display

Default	Parent menu item	Sub menu item
•	Sensor unit	<u>m</u> /cm/mm/ft/in
	Temperature unit	°C/K
	Language	Chinese/English

6.4.3 [Diagnostics]

[Diagnostics] Menu contains the necessary functions for historical record of the device. One can review the statistics of current and historical data.

Menu Item for Diagnostics

Default	Menu Item
•	Historical maximum measurement
	Historical maximum temperature
	Historical Fill rate
	Historical Empty rate
	Echo curve
	Historical period
	Historical data

6.4.4 [Advanced]

[Advanced] contains various advanced settings for complicate environment or demand. The option list is shown in the following table:

Menu Item for Advanced

Default	Menu Item
•	Near range
	Far Range
	Restore Factory
	Bus address
	Distance offset
	Current function
	4mA Setpoint
	20mA Setpoint
	Current simulation
	False Echo
	False echo range
	False echo mode
	Fill rate
	Empty rate
	Fail-safe current
	Fail-safe timer

6.5 Menu options

6.5.1 Basic

When the level meter is powered on, LCD enters measurement interface. Press the [ENT] key to enter [Basic] menu.

Note: Default settings indicated with an asterisk (*) unless explicitly stated.

Vessel Type



Vessel Type Overview

[Vessel Type] option has the impact on the radar algorithm based on the table below. Fill/Empty rate, damping time and tracking status are the main factors that would be changed automatically according to [Vessel Type].

Details for [Vessel Type]

Parameter name	Vessel type	
Large volume	Filling speed: 0.1m / min Damping time:60s	Filling speed: 0.1m / min Damping time:60s
Medium volume*	Filling speed: 1m / min Damping time:10s	Filling speed: 1m / min Damping time:10s
Fine volume	Filling speed: 10m / min Damping time: 0s	Filling speed: 10m / min Damping time: 0s
Demo	Damping time: 0s	Damping time: 0s

[Material Type/Dielectric Constant]



Material Type Overview

[Material Type] The setting is extremely important in complicate application such as low Dk liquid measurement. It should be selected according to the application.

Details for [Material type]

Solid		Liquid
Material type		Dielectric constant
Powder		> 10
Small solid		3-10
Large solid		<3

Low calibration point

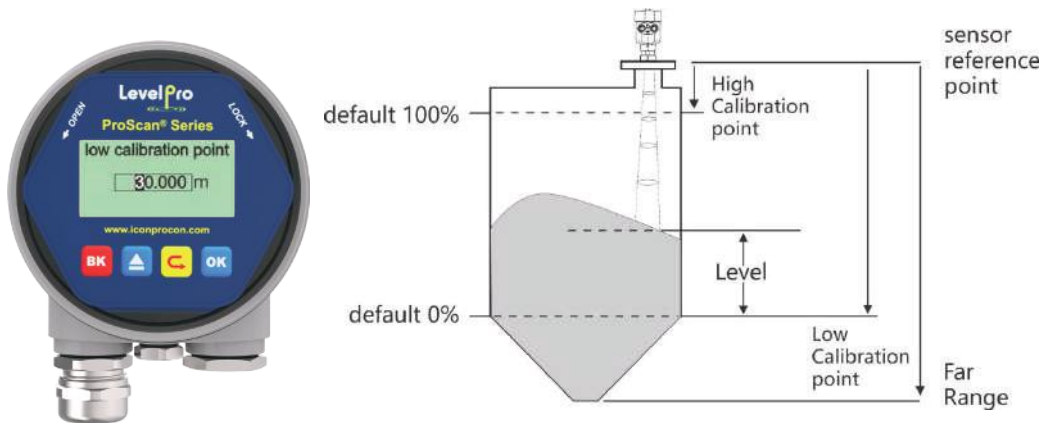

Low calibration point

[**Low calibration point**] (short for “**low cal.**”) relates to the range setting. It maps the corresponding relationship between the measured value and the current output (4-20mA) together with [**High calibration point**] (short for “**high cal.**”). Detailed input limitation for [**low cal.**] and the relationship between [**low cal.**] and [4ma/20ma setpoint] is summarized in following table.

Table12 Details for [**Low calibration point**]

Parameter name	Low calibration point		
Value Range (m)	1m ~ far range	1m ~ far range	1m ~ far range
Default value (m)	60	30	120
Related parameters	(1) If [low cal.] is less than ($[\text{high cal.}] + 0.1\text{m}$), it will be set to ($[\text{high cal.}] + 0.1\text{m}$). (2) In LEVEL mode, the 4mA setpoint will be automatically changed when changing Low calibration point . (3) In SPACE mode, the 20mA setpoint will be automatically changed when changing Low calibration point .		
Option meaning	(1) In LEVEL mode, it corresponds to [4ma setpoint]. (2) In SPACE mode, it corresponds to [20ma setpoint].		
Note	(1) No relation with far range. (2) Related to the Real-Time value and current output.		

6.5.1.4. [**High calibration point**]



High calibration point

[**High calibration point**] maps the corresponding relationship between the measured value and the current output (4-20mA) with [**low cal.**]. Detailed input limitation for [**high cal.**] and the relationship between [**high cal.**] and [4ma/20ma set-point] is summarized in the following table:

Table13 Details for [High calibration point]

Parameter name	High calibration point		
Value range (m)	0 ~ (low cal. -0.1m)	0 ~ (low cal. -0.1m)	0 ~ (low cal. -0.1m)
Default value (m)	0	0	0
Related parameters	(1) If [high cal.] is greater than ((low cal.)-0.1m), it will be set to ((low cal.)-0.1m). (2) In LEVEL mode, the 20mA setpoint will be automatically changed when changing High calibration point . (3) In SPACE mode, the 4mA setpoint will be automatically changed when changing High calibration point .		
Option meaning	(1)In LEVEL mode, it corresponds to [20ma setpoint]. (2)In SPACE mode, it corresponds to [4ma setpoint].		
Special matters	(1)No relation with near range . (2)Impact on the real-time value and current output.		

6.5.1.5. [Damping]

[Damping] smoothes out the response to a sudden change in level. In five time constants, the output rises exponentially: from 63% of the change in the first constant, to almost 100% at the end of the fifth time constant.

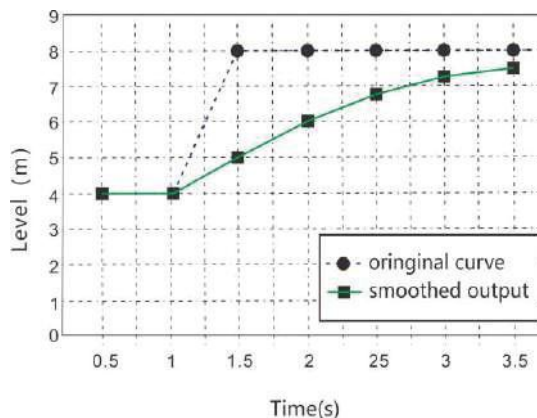

Fig.16 Damping

Table14 Details for [Damping]

Parameter name	Damping
Parameter range (s)	0~600
Default (s)	60
Related parameters	Null
Option meaning	Smooth out the response to a sudden change in level.
Special matters	Null

6.5.1.6. [Sensor Mode]



Sensor Mode

[Sensor mode] decides the specific display form of the **real-time value** and **damping value**. There are three kinds of forms: LEVEL, SPACE and DISTANCE. Detailed definition and calculation method is shown in the table below:

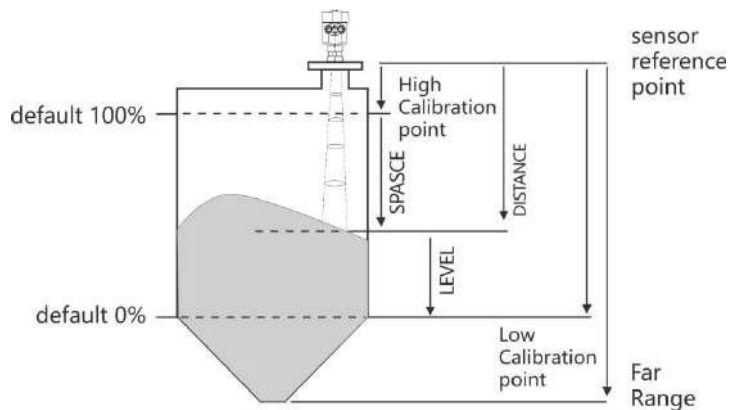

Definition for LEVEL, SPACE, DISTANCE

Table15 Details for [Sensor mode]

Parameter name	Sensor mode
Default	Distance
Related parameters	Null
Option meaning	Level: Distance from Low Calibration Point to material surface. Space: Distance from High Calibration Point to material surface. Distance: Distance from Sensor Reference Point to material surface.
Special matters	(1)In Distance mode: real-time value = measured distance. (2)In Level mode: Real-time value = [low cal.]-measured distance. If the measured distance is greater than [low cal.], LEVEL=0. (3)In Space mode: Real-time value = measured distance-[high cal.]. If the measured distance is smaller than [high cal.], SPACE=0.

Display

6.5.2.1. [Sensor unit]

[Sensor Unit] defines the unit of the **real-time value** and **damping value** shown in **Measurement Interface**.



6.5.2.2. [Temperature unit]

[Temperature Unit] defines the unit of temperature shown in **Measurement Interface**.



Temperature Unit

History Maximum Measurement

6.5.3.2. [Historical Maximum Temperature]

[Historical Maximum Temperature] shows the statistical results of the MCU operating temperature since last [Clean].



6.5.3.3. [Historical Fill Rate]

[Historical Fill Rate] shows the statistical results of measured maximum and minimum fill rate of the material.



Historical Fill Rate

6.5.3.4. [Historical Empty Rate]

[Historical Empty Rate] shows the statistical results of measured maximum and minimum filling rate of the material.



Historical Empty Rate

6.5.3.5. [Echo curve]

Refer to [Echo Interface].

6.5.3.6. [Historical period]

[Historical period] sets the time range of [Historical curve].



Historical Period

6.5.3.7. [Historical data]

According to [Historical period], [Historical data] shows the historical trend of the measurement. The data on the right is newer. The number in the upper left corner shows the maximum peak in the curve and [Historical period] is shown in the upper right corner. Maximum statistical period is 360 hours, i.e. 15 days.



Historical Data

6.5.4 Advanced

6.5.4.1. [Near range]

Only the Echoes between the ranges from [near range] to [Far range] would be considered and has the possibility to be chosen by the algorithm. And [near range] should not be set smaller than blind zone according to the corresponding modal, otherwise it may cause instability or wrong reading.



Near Range

Details for [near range]

Parameter name	near range		
Parameter range (m)	0~([far range]-0.1m)	0~([far range]-0.1m)	0~([far range]-0.1m)
Default value (m)	0	0	0
Related parameters	If [near range] is greater than ([far range]-0.1m), it will be set to ([far range]-0.1m).		

6.5.4.2. [Far range]

Only the Echoes between the ranges from **[near range]** to **[far range]** would be considered and has the possibility to be chosen by the algorithm.



Far range

Details for **[far range]**

Parameter name	far Range		
Parameter range (m)	0.1~60	0.1~30	0.1~120
Default value (m)	60	30	120
Related parameters	(1) If [far range] is set smaller than ([near range] + 0.1m), it will be automatically set to ([near range] + 0.1m). (2) In DISTANCE mode, [4ma setpoint] is directly related to [far range] .		

6.5.4.3. 【Factory reset】

It is used to restore the default factory settings of the level meter. The recovery time is about 15s to 20s. After that, LCD will jump to **Measurement Interface** automatically.



Factory reset

6.5.4.4. [Bus address]

[Bus Addresses] is used to assigning address for the instrument and guarantee multiple instruments

working properly on the bus. Set the bus address according to the corresponding protocol.



Bus address

Details for [Bus address]

Parameter name	Bus address	Hart address
Parameter range	1-247	0-15
Defaults	1	0
Related parameters	Null	Null
Option meaning	Set the Modbus address.	Set the Hart short address.
Special matters	System will reboot after setting	System will reboot after setting. Output Current will be fixed at 4mA when non-zero value.

6.5.4.5. [Distance Offset]

[Distance Offset] is used to compensate the shift of sensor reference point according to actual requirement. The default reference point is calibrated to the front end of the lens point “a”. If sensor reference point need to be set to point “b”, just input “h1”; or if it need to be set to point “c”, just input “-h2”.

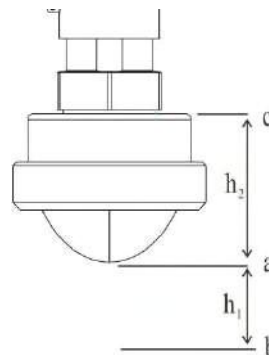

Distance Offset

Details for [Distance Offset]

Parameter name	Distance offset
Parameter range (m)	-(Selfoffset)~+10m

Default value (m)	0
Related parameters	Null
Option meaning	Compensate the shift of the sensor reference point.
Special matters	Null

6.5.4.6. [Current function]

[Current function] decides real-time output loop current according to [4ma/20ma setpoint].



Current function

In the different options, 4ma (0%) and 20ma (100%) position is shown in the figure. Choose the option according actual need.

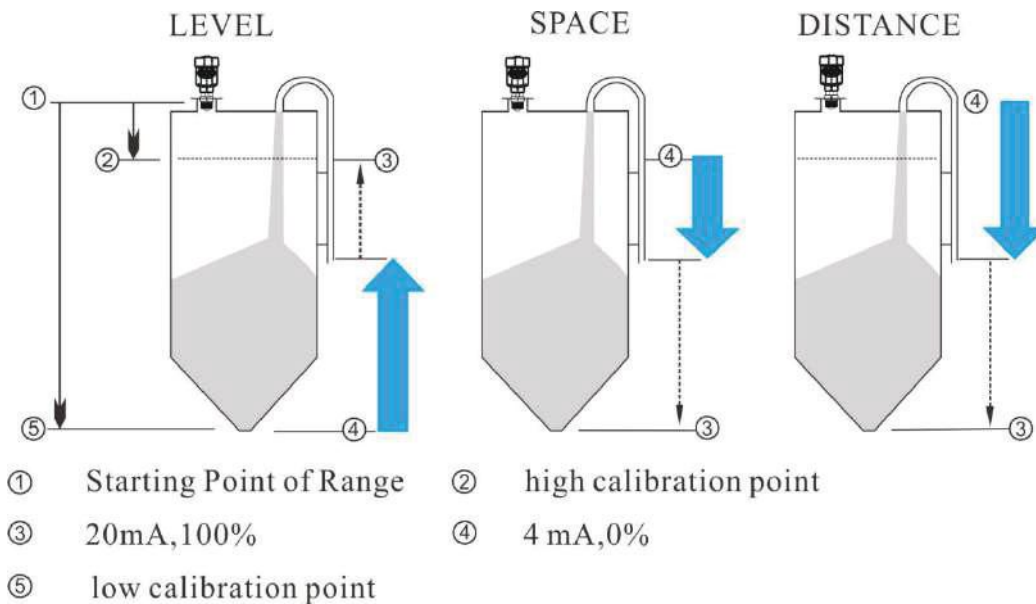

Corresponding relationship between 4/20ma setpoint and low/high calibration point

Details for Current function

Parameter name	Current function
Defaults	Level
Related parameters	Refer to Fig.34
Option meaning	Decide real-time loop current according to [4ma/20ma setpoint].
Special matters	The default 4ma and 20ma setpoint refer to the low/high calibration point or

the option [4ma setpoint] and [20ma setpoint] set manually.

6.5.4.7. [4ma setpoint]

Set the 4ma setpoint (0% position) individually and thus the default corresponding relationship between 4ma and [low/high cal.] would be discarded as a result.



Fig.35 4ma setpoint

6.5.4.8. [20ma setpoint]

Set the 20ma setpoint (100% position) individually and thus the default corresponding relationship between 20ma and [low/high cal.] would be discarded as a result.



Fig.36 20ma setpoint

6.5.4.9. [Current simulation]

[Current simulation] is used to check the loop current output accuracy. The loop current will keep the value set by [Current simulation] for testing. Once you exit the interface shown in Fig.37, calibration is over and the loop current would be set according to [Current function], which means that the instrument continues the normal measurement.



Current simulation

Details for Current simulation

Parameter name	Current simulation
Parameter range (ma)	4 ~ 20
Default (ma)	4
Related parameters	Null
Option meaning	Check the current output manually.
Special matters	Null

6.5.4.10. [False Echo]



False Echo

[False Echo] is used to form a specific TVT for the current environment with known obstructions or interference, and together with [False echo area] and [False echo mode]. It suppresses the unwanted echoes wherever it appears. Ideally the vessel should be empty or almost empty and thus all the potential false echoes would be learned. And if there is an agitator, it should be running. Example of False Echo Learning is shown in Fig.39.

Example before Auto False Echo Suppression

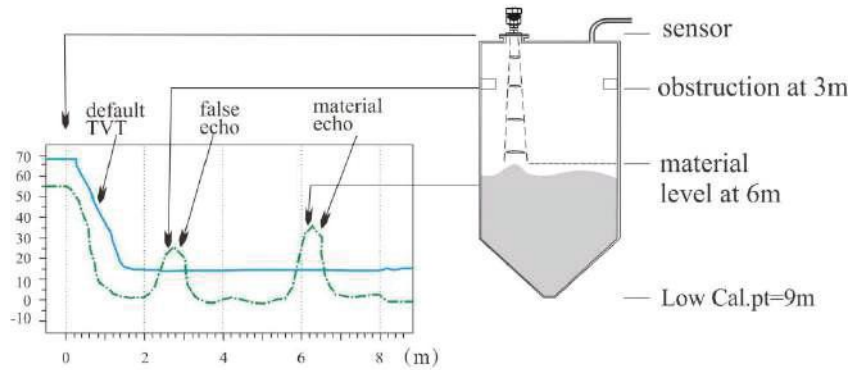

Example after Auto False Echo Suppression

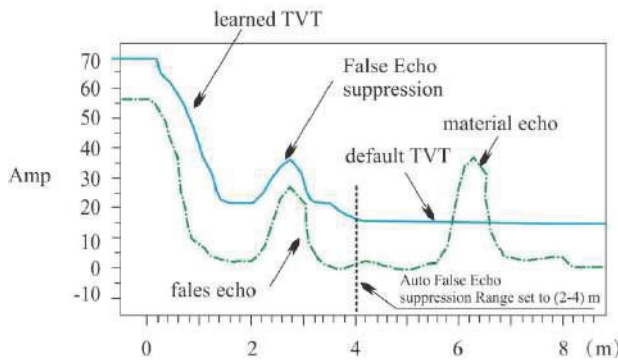

Fig.39 Example of False Echo Learning

Note: A Time Varying Threshold (TVT) hovers above the echo profile to screen out unwanted reflections (false echoes). In most cases the material echo is the only one which rises above the default TVT.

6.5.4.11. [False echo range]

False Echo Rang specifies the region within which the TVT is learned. It is invalid if the [False echo সড়ফব] রং “ভঁষষ ংধহমব” , which means the TVT is learned from [near range] to [far range]. The range need to be set carefully to avoid the material echo being screened out.



False echo range

Details for False echo range

Parameter name	False echo rang
Parameter range (m)	Start: 0 ~ far range End: (near range + 0.1m) ~ far range
Default value (m)	0
Related parameters	Null
Option meaning	Set range for false echo learning
Special matters	Null

6.5.4.12. [False Echo Mode]

[False echo mode] specifies the mode of false echo learning.



False Echo Mode

Assuming that the start of the false echo area is 2m and the end is 4m as shown in Fig.39, the meaning of the different option combinations is as follows:

Table23 Details for False echo mode

	Full range*	include region	Exclude region
New	false echo is learned from [near range] to [far range]	False echo is learned within 2m ~ 4m and the rest remains the same.	False echo is learned within full range exclude 2~4m and the rest remains the same.
Clear	Clear false echoes learned from [near range] to [far range]	Clear the false echo within 2m ~ 4m and the rest remains the same.	False echo is cleared within full range exclude 2m~4m, the rest remains the same.

6.5.4.13. [Fill rate]

[Fill rate] is used to adjust the response rate of the level meter to the increases of the actual material level. [Fill rate] need to be set according to the actual situation, or the default setting would be applied as in Section 6.5.1.1.



Fill Rate

6.5.4.14. [Empty rate]

[Empty rate] is used to adjust the response rate of the level meter to the decrease of the actual material level. [Empty rate] need to be set according to the actual situation, or the default setting is applied as in Section 6.5.1.1.



Empty Rate

Table24 Details for False Fill/Empty rate

Parameter name	Fill/Empty rate
Parameter range (m / min)	0~300
Default value (m / min)	0.1
Related parameters	Null
Option meaning	Set the response rate for material tracking
Special matters	Only work in tracking mode

6.5.4.15. [Fail-safe mode]

[Fail-safe mode] is used to set the output current when the level meter encounters a fault together with [Fail-safe Timer]. The “Keep” option indicates the last valid measured current would be output. Detailed error code refers to **Error Code**.



Fail-safe Mode

6.5.4.16. [Fail-safe Timer]

It is also known as lost of echo timer (LOE timer). Fail-safe mode would be turned on when [Fail-safe Timer] expires. The default value is 100s and the range is 0-1000s.



Fail-safe Timer

6.5.5 Information

Information contains four items: [Lcd version], [Device version], [Model], [Serial NO.]and [Tag]. [Lcd version] and [Device version] carry the information of the software and hardware that the instrument is running on.



LCD Device Version

[Model] shows the product model.



Sensor Model

[Serial NO.] shows the product Serial Number



Serial NO.

[Tag] is used to set the unique identification for each instrument. It contains 16 characters and each character can be set to '0' ~ '9' or 'a' to 'z'.



Tag

6.6 Keyboard input method

This section is to introduce the method of inputting digital number for setup in [Input Interface],
(1) Press [DN] to shift the cursor to the right.



Shift the cursor

(2) Press [UP] to cycle from 0 to 9.



Cycle from 0 to 9

(3) Press [ENT] to complete the setting and "OK" will be displayed in the lower right corner of the LCD for 1 second, which means setting is accomplished.



Successful setting

7. Menu tree

7.1 First-level menu tree

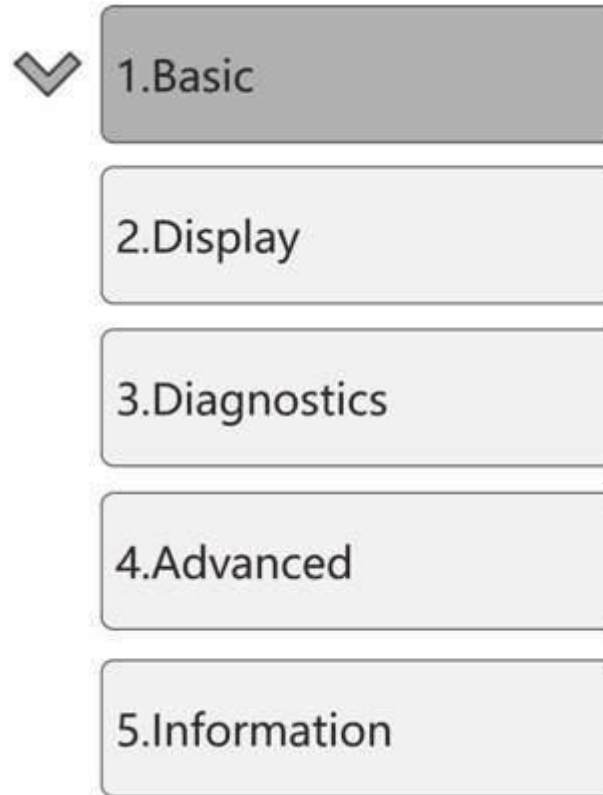

7.2 Secondary menu tree-basic settings

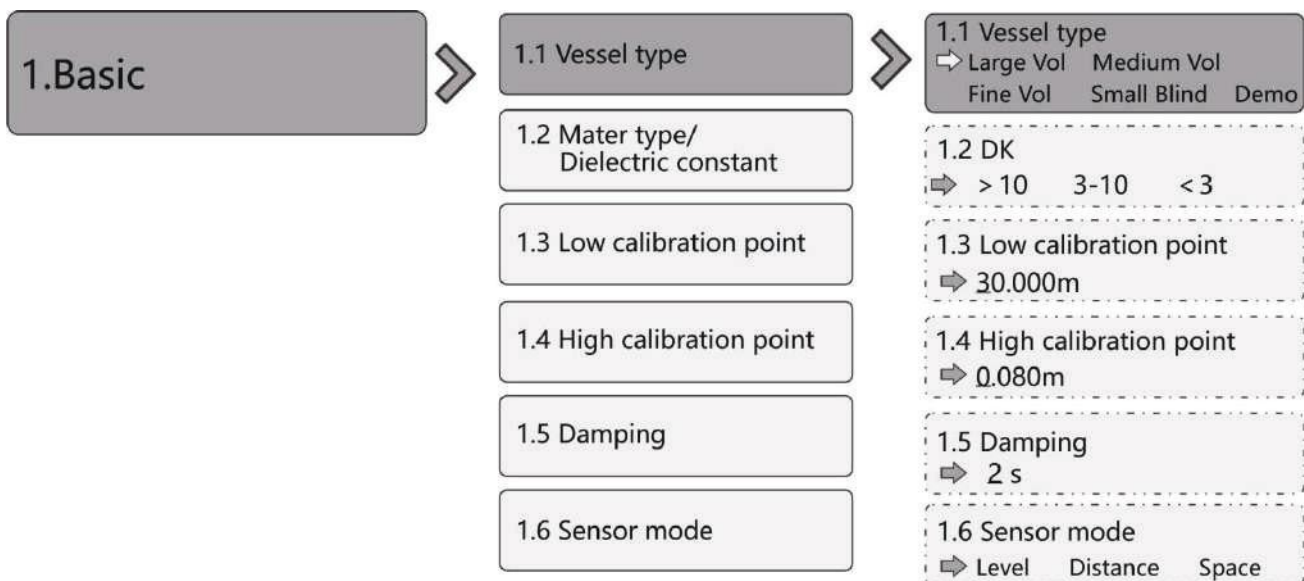

7.3 Secondary menu tree-display

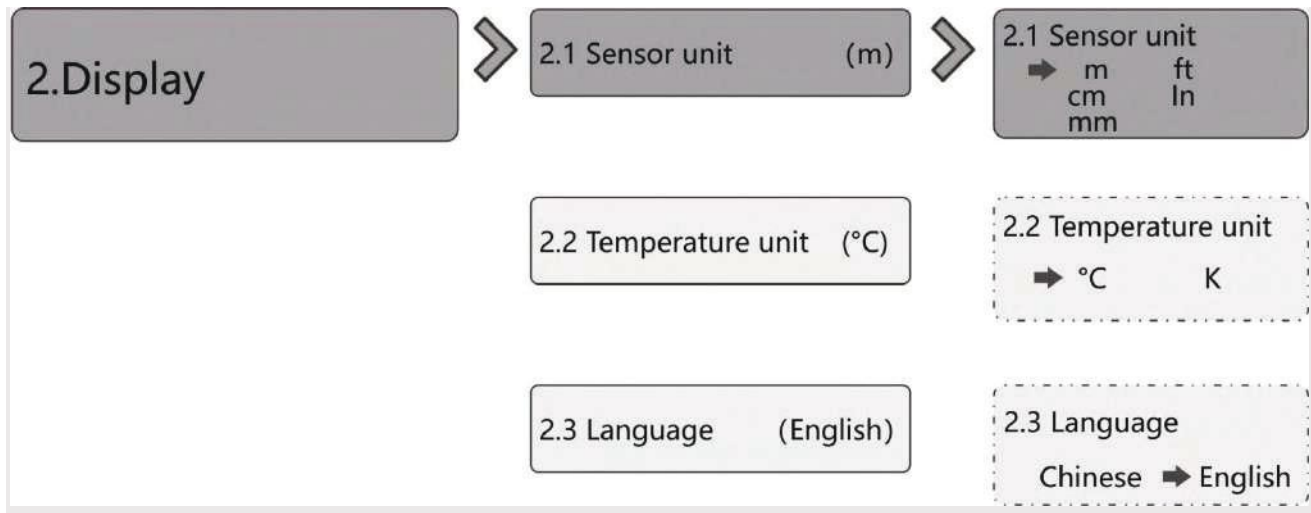

7.4 Secondary menu tree-diagnostics

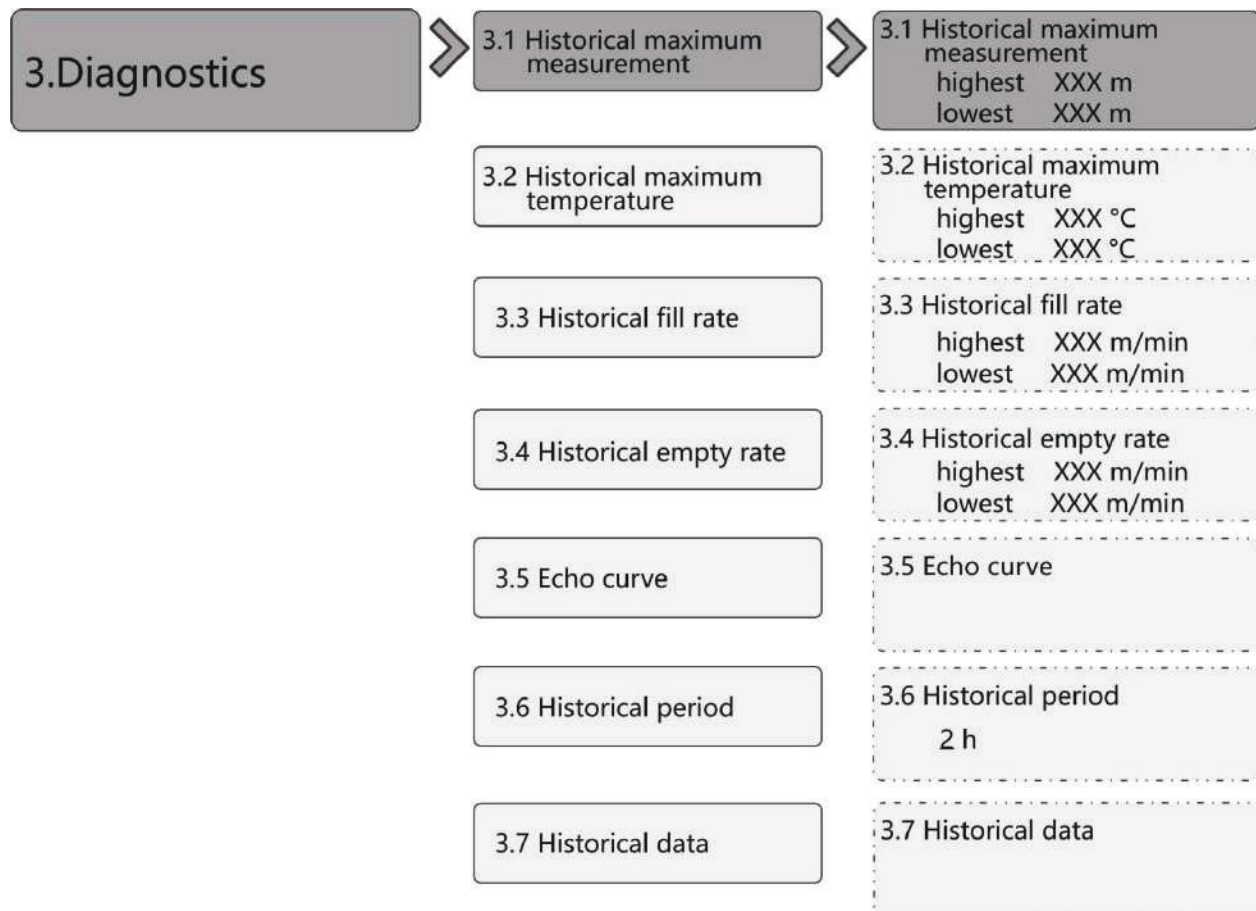

7.5 Secondary menu tree-Advanced

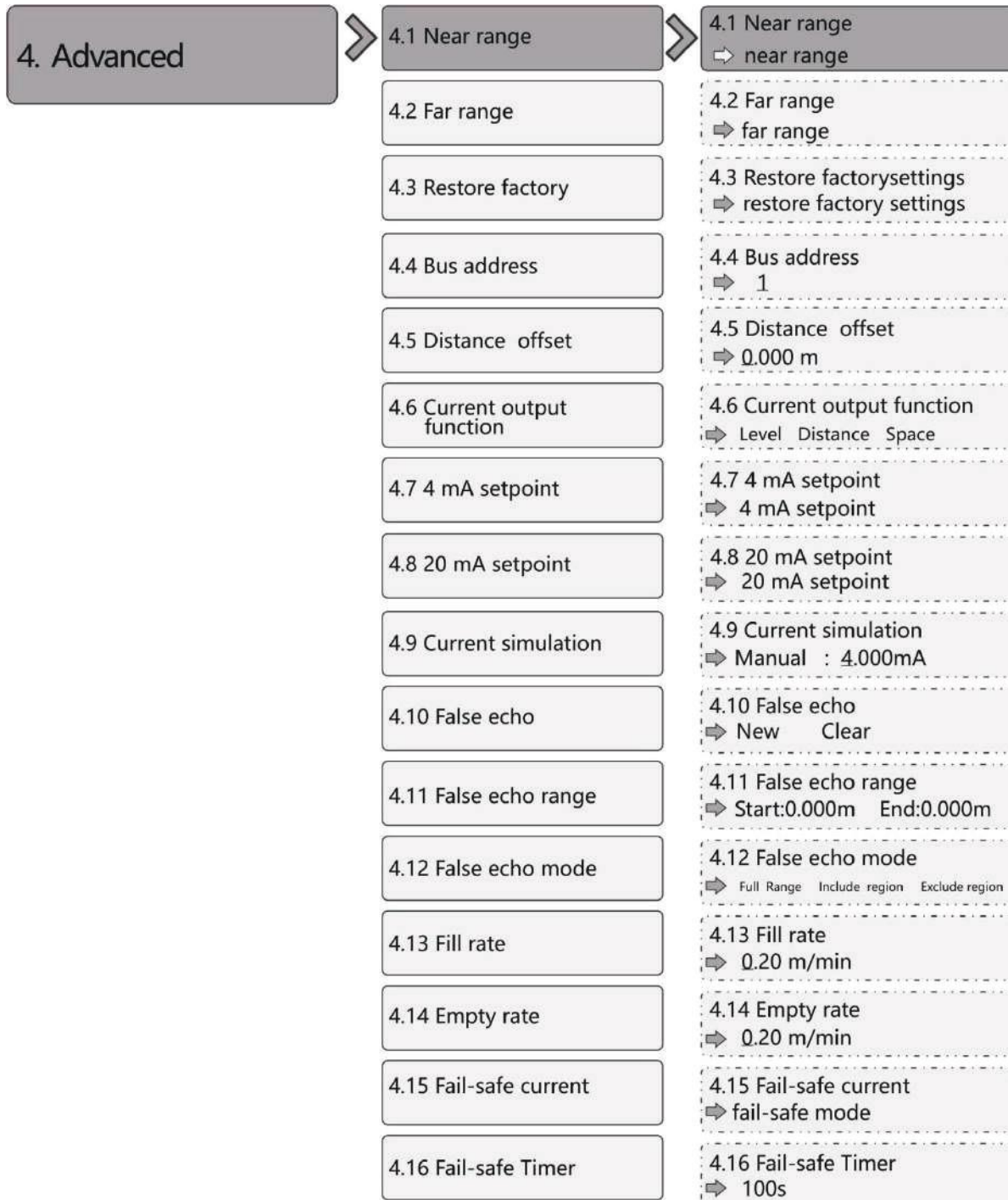

7.6 Secondary menu tree-information

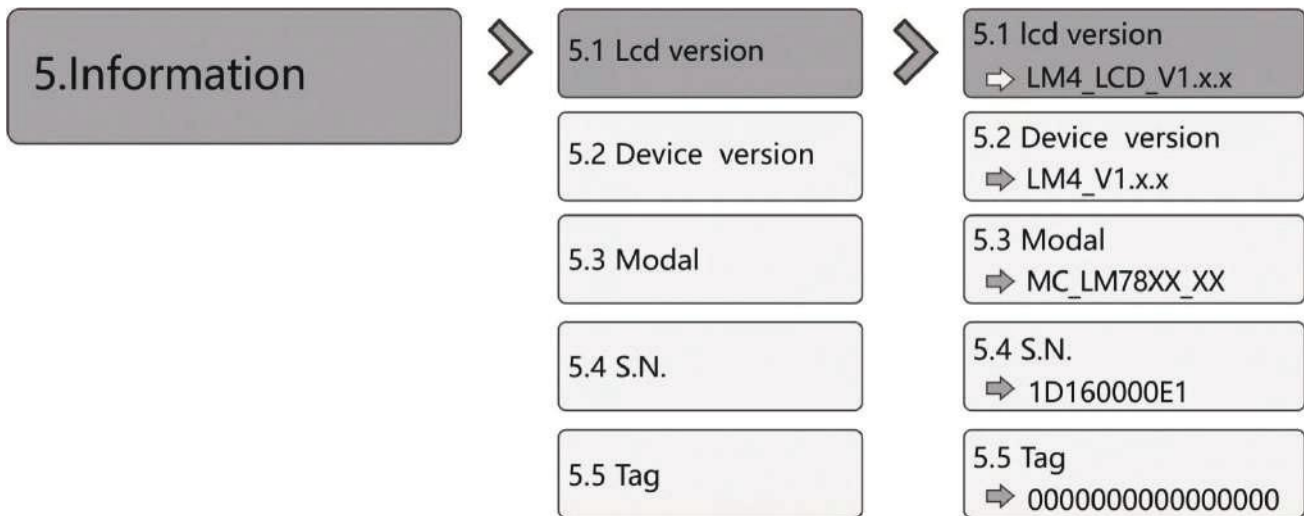

8. Error Code

Error code is displayed in the Measurement Interface as shown below



Fig.52 Error code

Table25 Details for Error code

Index	Binary	Hex	Meaning
1	0000 0000 0000 0000	0000	Work regular
2	0000 0000 0000 0001	0001	Lost echo
3	0000 0000 0000 0010	0002	Communication err with TR
4	0000 0000 0000 0100	0004	No Factory False echo study
5	0000 0000 0000 1000	0008	4-20ma error
6	0000 0000 0001 0000	0010	Current manual output
7	0000 0000 0010 0000	0020	LCD Communication error
8	0000 0000 0100 0000	0040	Connection err with TR
9	0000 0000 1000 0000	0080	MCU Hard fault
10	0000 0001 0000 0000	0100	MCU Hard fault
11	0000 0010 0000 0000	0200	Temperature sensor error
12	0000 0100 0000 0000	0400	MCU Hard fault

9. Glossary

Beam Angle: Half power beamwidth. Lm78xx has 3° beamwidth and the divergence of the beam is only ±2.6m at a distance of 100m.

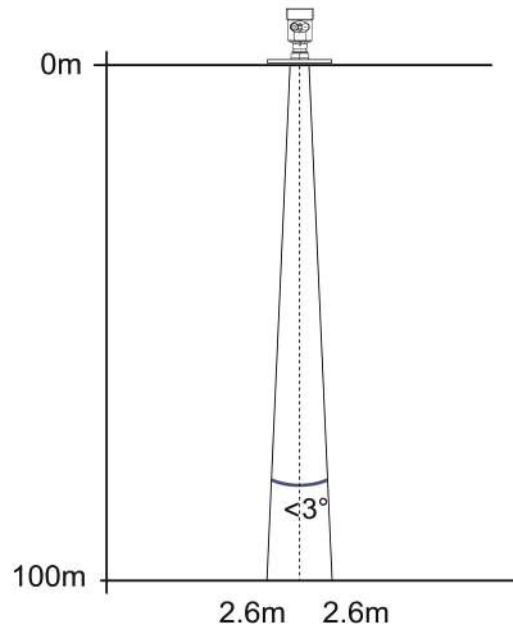

Beam spread

Range resolution: It refers to the minimum distance that two objects can be distinguished by the level radar. LM78xx has a 5.1GHz bandwidth, and thus the ideal

Range resolution= $C/2B \approx 3\text{cm}$ **Measurement Accuracy:** The minimum shift that can be distinguished by the level radar. LM78xx's echo signal is analyzed by unique algorithm, and the accuracy is 0.5mm.

Ambient temperature: The temperature of the surrounding air that comes in contact with the equipment.

Blind zone: the limitation of the level meter, that is to say, the radar cannot give the right measured result within Blind zone.

dB (decibel): A unit representing the amplitude of a signal.

Dielectric constant (DK): The ability of a dielectric to store electrical energy. The increase in dielectric constant is directly proportional to the increase in reflection amplitude. The dielectric constant of air is 1.

Echo: A reflected signal with amplitude large enough to be distinguished from the transmitted signal by a certain method is called an echo.

False echo: Echoes that are not the one of the real target. Generally speaking, false echoes are generated by obstacles in the container.

Multiple echoes: Multiple echoes due to multiple reflections between the radar and the target

Polarization: The properties of the emitted electromagnetic waves, describing the direction and amplitude of the electric field vector changes over time.

Repeatability: The variance of multiple measurements of the same variable in the same situation.

Speed of light: The speed of electromagnetic waves in free space is 299,792,458 meters per second.