

Uninterruptible Power Supply User Manual

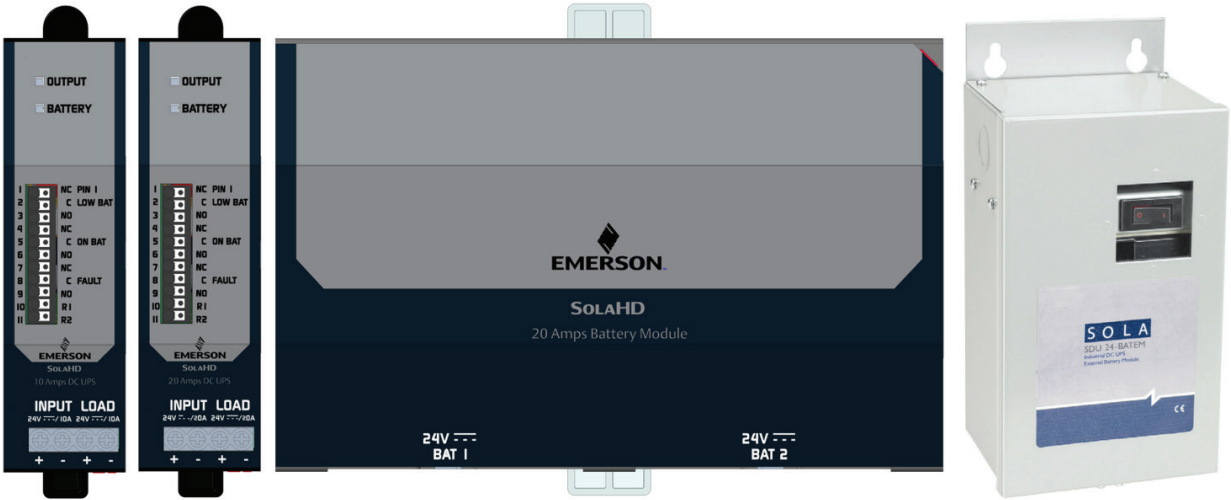

SDU DC UPS B-Series

Contents

Safety Instructions	1	UPS Battery	13
Introduction.....	2	Battery Types.....	13
Preinstallation.....	2	Batteries for SDU-24 BATB	13
Receiving.....	2	Batteries for SDU-24 BATEM	13
What's Included.....	2	Charging/Recharging the Battery	13
Battery Options	2	Battery Backup Times (Minutes [min.]).....	14
Optional Accessories	2	SDU 10-24B with SDU 24-BATB.....	14
Product Description.....	3	SDU 20-24B with SDU 24-BATB.....	14
Installation	4	SDU 10-24B with SDU 24-BATEM	14
Location	4	SDU 20-24B with SDU 24-BATEM	14
DIN Rail Mounting	4	Specifications	15
Removing the Unit from the DIN Rail	4	Power Module Specifications	15
Optional Chassis Mounting	5	Battery Module Specifications	18
Connecting the Unit - Wiring Diagrams	8	Troubleshooting.....	19
SDU DC UPS B-Series with SDU 24-BATB	8	Troubleshooting	19
SDU DC UPS B-Series with SDU 24-BATEM	9	SOLAHD Technical Support.....	19
Operation.....	10	Storage	20
Turning ON the UPS (Normal Mode)	10	Extended Storage	20
Turning OFF the UPS	10	Technical Support.....	21
Remote ON/OFF	10	Warranty.....	21
Self-Testing.....	10	Warranty Information	21
LED Status	11	Product Literature	21
Contact Relay Truth Table	12		

Safety Instructions

IMPORTANT - READ AND FOLLOW THE SAFETY INSTRUCTION SHEET THAT IS PROVIDED WITH THE SDU 10-24B, SDU 20-24B, SDU 24-BATB OR SDU 24BATEM MODULES. THESE INSTRUCTIONS MUST BE FOLLOWED DURING INSTALLATION, OPERATION, MAINTENANCE AND DISPOSAL OF THE UNIT.

⚠ WARNING - Explosion Hazard, Risk of Electric Shock, Fire and Personal Injury

Follow all warnings on the product, in the Safety Instruction Sheets and in this manual. Failure to do so may result in serious injury or death.

Document	Part No.
Safety Instruction Sheet – SDU 10-24B, SDU 20-24B DC Uninterruptible Power Supplies	A272-367
Safety Instruction Sheet – SDU 24-BATB DC Uninterruptible Power Supply Battery Module	A272-368
Safety Instruction Sheet – SDU-BATEM DC Uninterruptible Power Supply Battery Module	A272-369

Introduction

Congratulations on your choice of the SDU DC B Series Uninterruptible Power System (UPS). The SDU DC is an advanced 24 Vdc UPS that combines an industry leading design, unique installation options, and a wide operational temperature range (see “Specifications”).

The SDU DC is a powerful microprocessor-controlled UPS which provides protection from power interruptions and is the ideal power backup solution for your critically connected loads.

Preinstallation

Receiving

Inspect the UPS upon receipt. Damage that may have occurred in transit is not covered under the warranty. If shipping damage is present, contact your local carrier and SolaHD distributor immediately.

What's Included

- SDU 10-24B or SDU 20-24B
- Safety Instruction Sheet
- Remote On/Off Bypass Jumper

Battery Options

Two battery modules are available:

- SDU 24-BATB: 24 V DIN rail/panel mount battery module (cable and Safety Instruction Sheet included).
NOTE: Up to 4 SDU 24-BATB modules can be connected to the UPS.
- SDU 24-BATEM: 24 V external mount battery module (cable and Safety Instruction Sheet included).
NOTE: Only 1 SDU 24-BATEM module can be connected to the UPS.
NOTE: A combination of both modules cannot be used with the UPS.

Optional Accessories

- SDU 24EXTBC1B: 1ft (30.5cm) battery module cable.
- SDU 24-DB9: Interface kit to convert relay contact signals to DB9 signals.
- SDU-PMBRK: Chassis mounting brackets to secure the UPS to the wall, back of the panel, or enclosure.
- SDU 24EXTBC6B: 6ft (182.9 cm) external battery module cable.

Product Description

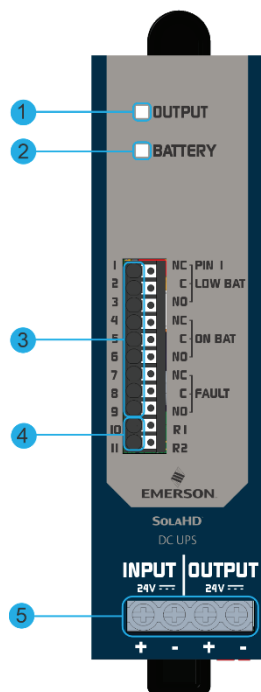

Figure 1

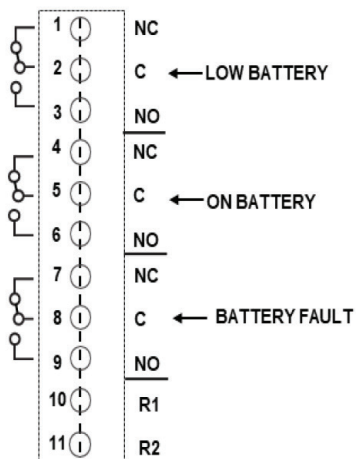

Figure 2

1. Output LED: Indicates the output status of the DC UPS. See Table 1.
2. Battery LED: Indicates the status of the battery module connected to the DC UPS. See Table 1.
3. Contact Relay Terminals: The control module incorporates dry relay contacts for remote signaling of the UPS and battery module status.
4. Remote ON/OFF Terminals (R1 and R2): Turns the unit ON/OFF.
5. DC Input/Output Screw Terminal Connections: IP20 rated input and output screw terminals.

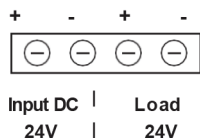

Figure 3

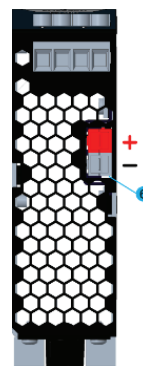

Figure 4

6. Polarized Terminal Connections for the Battery (+ Red color; - Black color).

Installation

Location

Install the power module and battery module in a protected area with adequate airflow and free of excessive dust. Do not operate the UPS outdoors.

DIN Rail Mounting

1. Tilt and place the unit onto the DIN rail.
2. Push the unit downward until it stops.
3. Push at the lower front edge to lock. Ensure that the retainer has locked.

Removing the Unit from the DIN Rail

Push the button and swing the bottom out and up.

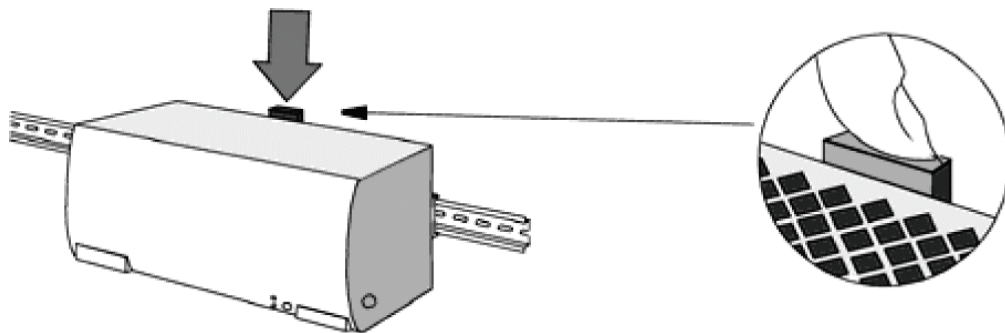

Figure 5

Optional Chassis Mounting

Optional chassis mounting brackets (P/N: SDU-PMBRK) are sold separately. Please refer to the installation instructions supplied with the brackets.

NOTE: If you will be shipping the UPS already mounted, we recommend using the chassis mounting brackets (P/N: SDU-PMBRK) to secure the UPS.

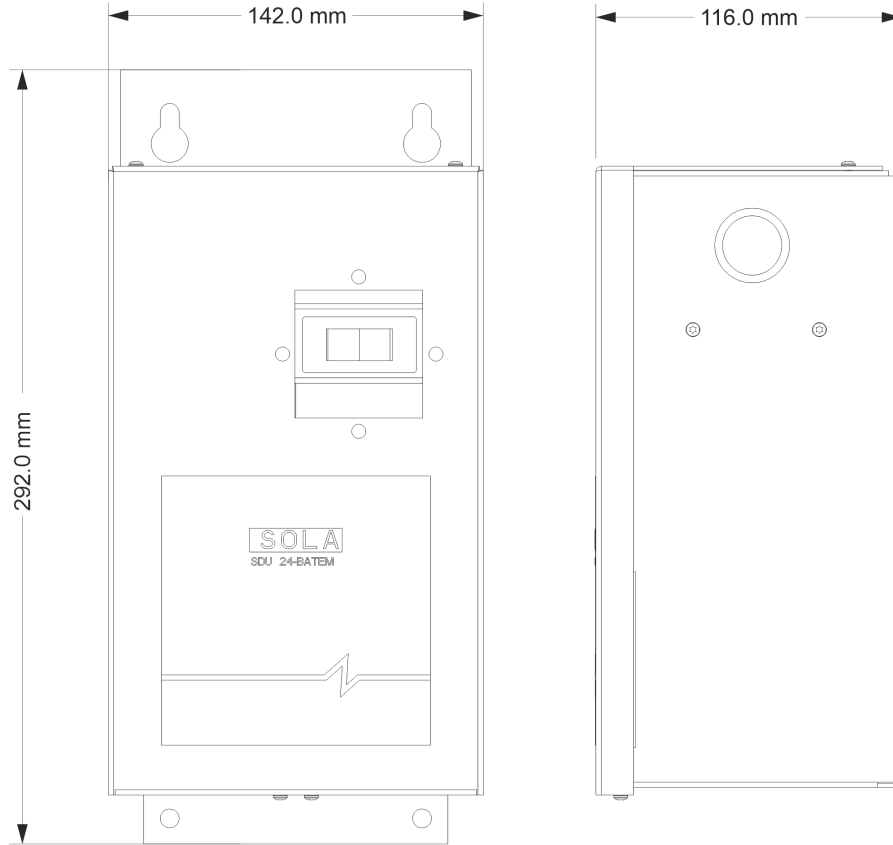

Figure 6

Table 1			
Catalog Number	Dimensions - Inches (mm)		
	H	W	D
SDU 24-BATEM	11.50 (292.0)	5.60 (142.0)	4.60 (116.0)

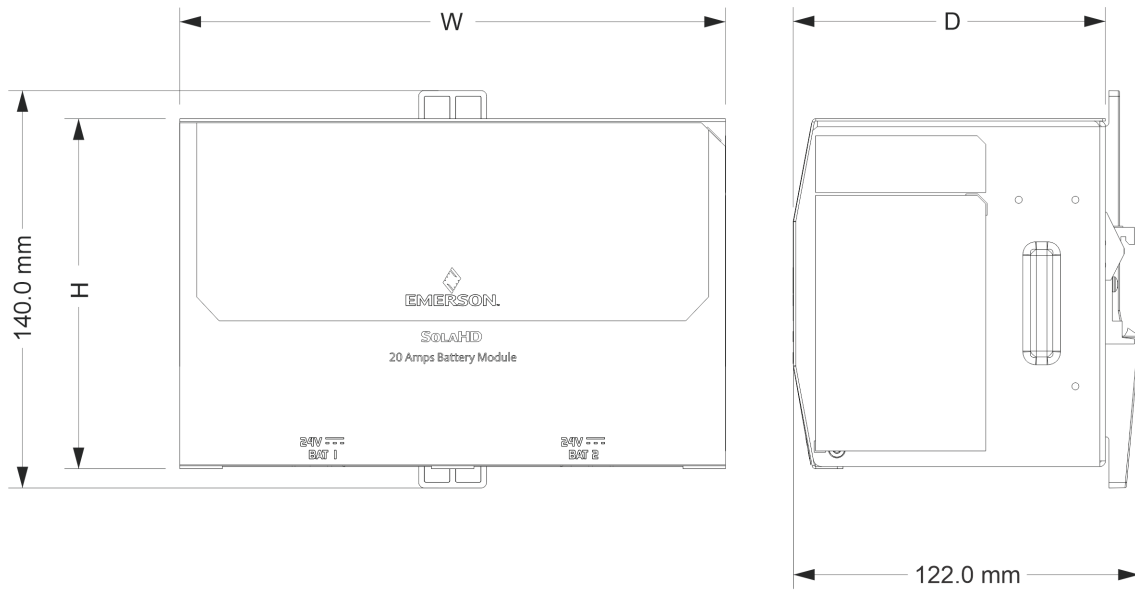

Figure 7

Table 2			
Catalog Number	Dimensions - Inches (mm)		
	H	W	D
SDU 24BAT-B	4.88 (124.0)	7.60 (192.4)	4.33 (110.0)

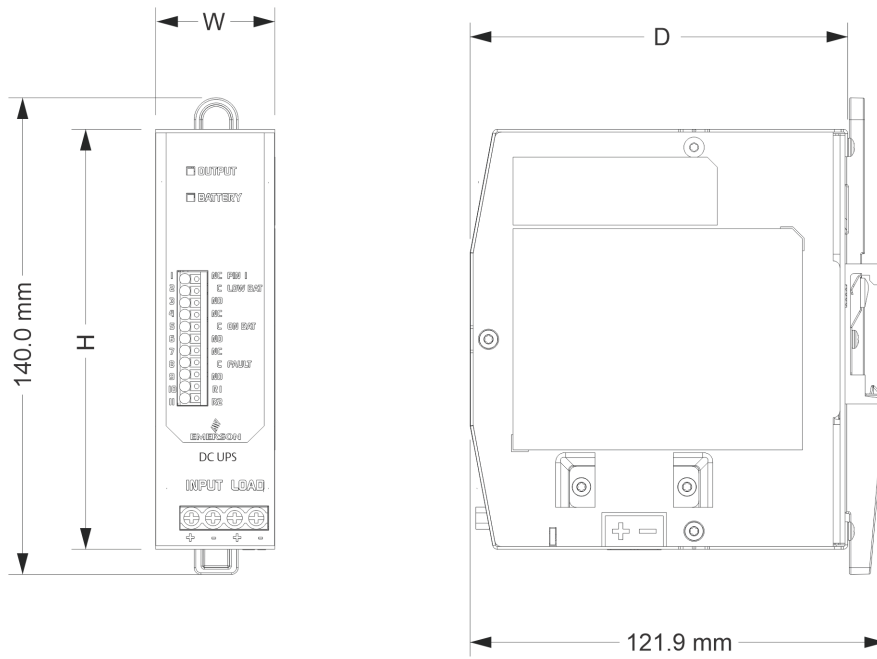

Figure 8

Table 3			
Catalog Number	Dimensions - Inches (mm)		
	H	W	D
SDU 10-24-B / SDU 20-24B	4.88 (124.0)	1.37 (35.0)	4.36 (111.0)

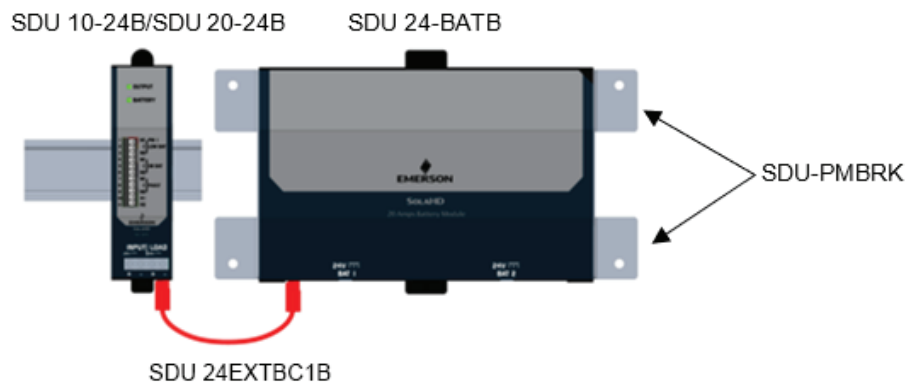

Figure 9

Connecting the Unit - Wiring Diagrams - SDU DC UPS B-Series with SDU 24-BATB

⚠ WARNING - Risk of electric shock and energy hazard!

Refer to the Safety Instruction Sheet provided with the products.

This device receives input power from multiple sources. Disconnect the DC UPS input from the AC to DC power supply connection and the DC Battery Modules before wiring.

Follow all local, National Electrical Code® (NEC®) and CEC wiring and installation codes.

Operate the UPS only from a properly grounded (earthed) DC supply.

To reduce the risk of electric shock, do not remove the cover. For service, contact a qualified technician.

Wiring/Torque Specification: Use only 90degreeC rated copper wire

Terminals	Gauge Size	Torque
Input/Output	10-14 AWG (5.3-2.1mm ²) for solid and stranded conductors	4.4-6.5lb-inch (50-73 N-cm)
Contact Terminal Connections (1-9)	16-24 AWG (1.3-0.2mm ²) for solid and stranded conductors for solid and stranded conductors. 18-24 AWG (0.75-0.2mm ²) wire gauge for conductors with ferrule	N/A
Contact Terminal Connections (10-11)	Use attached R1/R2 jumper. In lieu of jumper use 16-24 AWG (1.3-0.2mm ²) for solid and stranded conductors. 18-24 AWG (0.75-0.2mm ²) wire gauge for conductors with ferrule	N/A

Note: Use a Phillips head screwdriver to release the wire from the terminal. Other tools may damage the push terminal.

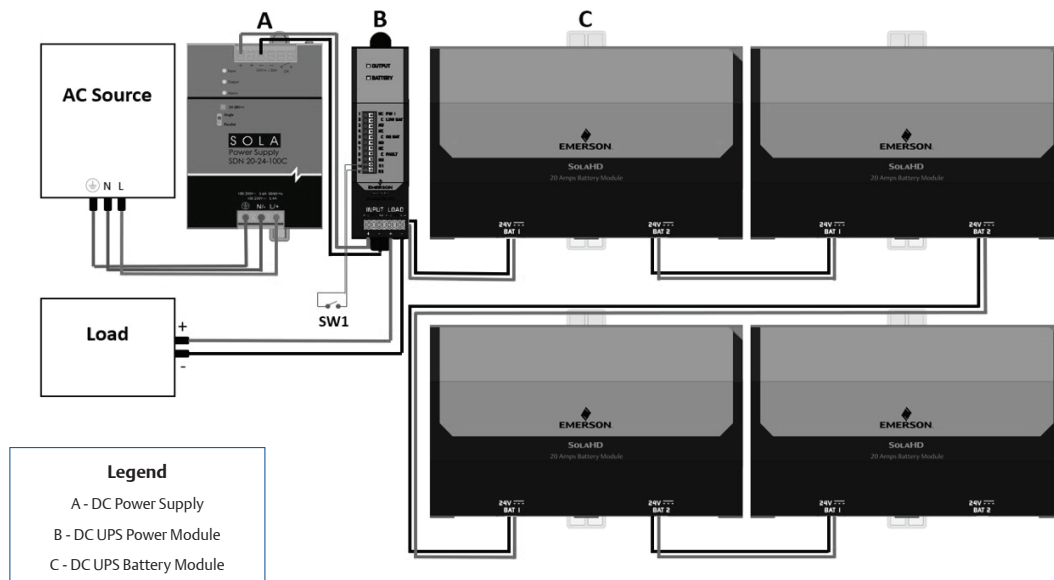

Figure 10

Connections:

1. Use the polarized cable to connect the power module to the battery module.
2. Connect the power module dc input connector to the 24 Vdc input power source.
3. Hardwire the load to the power module output terminal connector.

SDU DC UPS B-Series with SDU 24-BATEM

⚠ WARNING - Risk of electric shock and energy hazard!

Disconnect the DC input's AC supply connection before wiring. Operate the UPS only from a properly grounded (earthed) DC supply. To reduce the risk of electric shock, do not remove the cover. For service, contact a qualified technician.

⚠ WARNING - Risk of explosion.

The SDU 24-BATEM Battery Module IS NOT FOR USE IN A HAZARDOUS LOCATION ENVIRONMENT. Do not install the SDU 24-BATEM in a hazardous location environment.

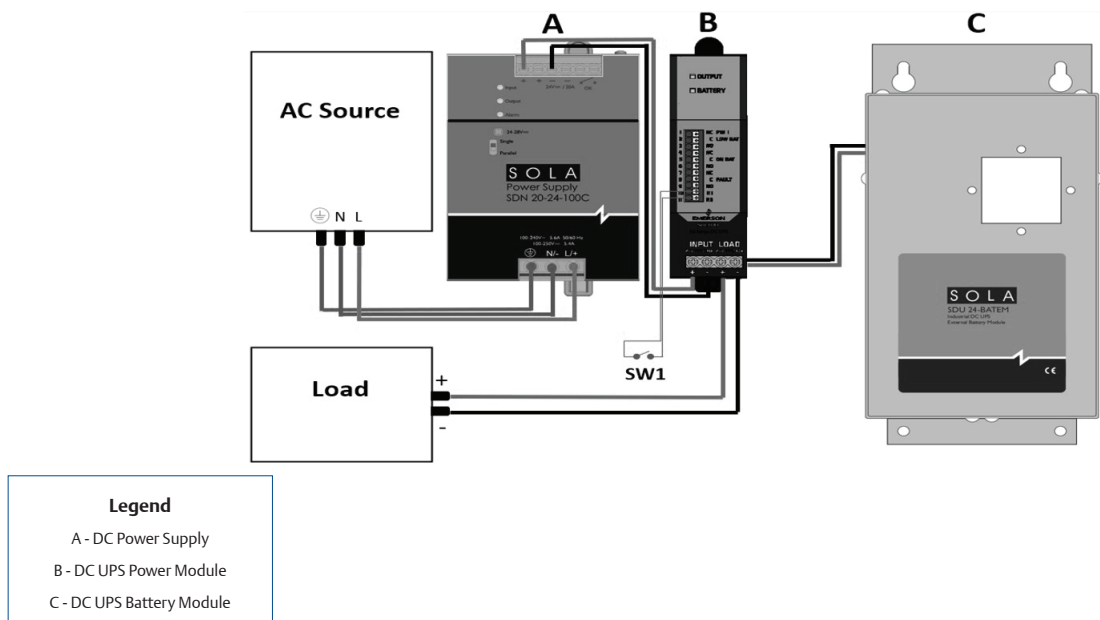

Figure 11

Connections:

1. Use the polarized cable to connect the power module to the battery module.
2. Connect the power module dc input connector to the 24 Vdc input power source.
3. Hardwire the load to the power module output terminal connector.

Operation

Turning ON the UPS (Normal Mode)

1. Ensure that the DC input supply is de-energized prior to wiring the DC UPS system.
2. Ensure that the Battery Module meets the charge schedule.
3. Ensure that the Remote ON/OFF toggle switch for R1 and R2 is open (if using Remote ON/OFF Bypass Jumper, make sure it is disconnected).
4. Connect the DC input to the DC UPS module; connect the Battery Module to the UPS module; then, connect the load to the UPS module.
5. Energize the DC input supply.
6. Enable the DC UPS by shorting R1 and R2 through the Remote ON/OFF toggle switch (if not using toggle switch, insert the Remote ON/OFF Bypass Jumper).
7. This will start the UPS in Normal Mode.

Note: If the DC input supply is not present, the DC UPS will enable Battery Mode. The load will be powered by the battery module until reaching cutoff voltage (21.6V). Please ensure switch is OFF or ON/OFF Bypass Jumper is removed when UPS is not in use to prevent draining of the battery.

Turning OFF the UPS

1. Disable the DC UPS by disconnecting R1 and R2 through turning off the Remote ON/OFF toggle switch (if not using a toggle switch, remove the Remote ON/OFF Bypass Jumper).
2. De-energize the DC input supply.
3. Disconnect the DC input supply, Battery Module, and the load.

Remote ON/OFF

Turns UPS output on when terminals R1 and R2 are shorted.

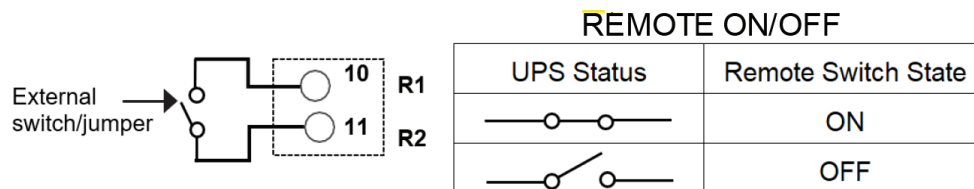

Figure 12

NOTE: The Remote ON/OFF is connected to the DC UPS internal signal ground and it should be isolated from the chassis ground potentials that may cause unit malfunction or damage. Isolate the Remote Sense wiring away from high current, high voltage, and high frequency components to prevent any magnetically coupled noise on the Contact Terminal Connections.

Self-Testing

The DC UPS employs an Automatic Self-Test feature. This feature checks the Battery Module's health and serves as indicator if the battery is still in good condition. The first Self-Testing will be activated 5 hours after commissioning. The subsequent Self-Testing will happen every 1 month thereafter. If the Battery Health fails the Self-Test, the Battery LED will display Solid Red.

LED Status

Table 4

Operating MODE		LED Signal
	Load Condition / Control Module Status	Output LED
NORMAL (input present)	Load Within Range (100% < I _{out} < 120%)	Steady Green
	Overload (125% – 150% for >4s) Power Boost	Green Flashing (0.25s ON : 0.25s OFF)
	Overcurrent and Short Circuit Protection	Red Flashing (1s ON : 1s OFF)
	Overtemperature Protection	Steady Red
BATTERY (Input loss)	Battery Mode & Load Within Range	Green Flashing (0.5s ON: 0.5s OFF)
	Overtemperature Protection	Steady Red
	Battery Condition	Battery LED
NORMAL (input present)	Battery Full	Steady Green
	Battery Charging / <50% Capacity	Green Flashing (0.25s ON : 0.25s OFF)
	Battery Charging / >50% Capacity	Green Flashing (1s ON : 1s OFF)
BATTERY (Input loss)	Battery Mode & Load Within Range	OFF
	Overtemperature Protection	OFF
BATTERY FAULT	Shorted Battery, Battery Overvoltage, reverse polarity, end of life or no battery.	Steady Red

Contact Relay Truth Table

Table 5

UPS Status	Low Battery		On Battery		Battery Fault	
	Pin 1-2	Pin 2-3	Pin 4-5	Pin 5-6	Pin 7-8	Pin 8-9
	N.C.	N.O.	N.C.	N.O.	N.C.	N.O.
Normal mode	O	X	O	X	O	X
Battery mode (30-100% SOC)	O	X	X	O	O	X
Battery mode - Low Battery (20-30% SOC)	X	O	X	O	O	X
Battery fault	I	I	I	I	X	O

Legend:

- X – Contact close
- O – Contact open
- I - Indeterminate
- N.C. - Normally close
- N.O. - Normally open

UPS Battery

CAUTION

- Do not attempt to open the DC UPS or replace the batteries inside the battery module.
- Call SolaHD Technical Support for further instructions.
- Do not mount the DC UPS or the Battery Module in an upside-down orientation.

Battery Types

Table 6

Batteries for SDU-24 BATB		
Manufacturer	Type	Rating
CSB	HRL 1225W	12 V dc, 5.0 Ah
Taiwan Yuasa Battery Co. Ltd.	NPX25	

Table 7

Batteries for SDU-24 BATEM		
Manufacturer	Type	Rating
CSB	GP1272	12 V dc, 7.2 Ah

WARNING - Battery Disposal

Do not dispose of batteries in a fire; they may explode. Do not open or mutilate the battery. Released electrolyte is harmful to skin and eyes and may be toxic. Proper disposal of batteries is required. Refer to your local laws and regulations for disposal requirements.

Charging/Recharging the Battery

Locate the recharge label on the box containing the product. The label will indicate the last recharge date. Please refer to the label for the next recharge due date.

If the product is due for recharge, please follow the wiring diagram Figure 10 to recharge the SDU 24-BATB. Please allow 8 hours to fully recharge a battery.

Once the battery is recharged, please create a LOG and track the due dates to properly maintain the charge.

Battery Backup Times (Minutes [min.])

Table 8

SDU 10-24B with SDU 24-BATB					
Load	20% (2 A)	40% (4 A)	60% (6 A)	80% (8 A)	100% (10 A)
1 unit	113 min.	45 min.	30 min.	21 min.	14 min.
2 units	247 min.	114 min.	74 min.	48 min.	38 min.
3 units	396 min.	178 min.	117 min.	80 min.	58 min.
4 units	531 min.	233 min.	148 min.	111 min.	81 min.

Table 9

SDU 20-24B with SDU 24-BATB					
Load	20% (4 A)	40% (8 A)	60% (12 A)	80% (16 A)	100% (20 A)
1 unit	46 min.	21 min.	10 min.	6 min.	4 min.
2 units	116 min.	50 min.	28 min.	17 min.	10 min.
3 units	178 min.	80 min.	46 min.	31 min.	20 min.
4 units	237 min.	113 min.	65 min.	43 min.	31 min.

Table 10

SDU 10-24B with SDU 24-BATEM					
Load	20% (2 A)	40% (4 A)	60% (6 A)	80% (8 A)	100% (10 A)
1 unit	135 min.	52 min.	28 min.	19 min.	14 min.

Table 11

SDU 20-24B with SDU 24-BATEM					
Load	20% (4 A)	40% (8 A)	60% (12 A)	80% (16 A)	100% (20 A)
1 unit	48 min.	17 min.	9 min.	6 min.	4 min.

NOTE: Run times are based on new, fully charged battery module at a temperature of 25°C (77°F) with purely resistive DC UPS load. Run times listed above may vary due to manufacturing variances of the individual batteries.

Specifications

Table 12

Power Module Specifications		
Parameter	Catalog Number	
	SDU 10-24B	SDU 20-24B
Nominal Input Voltage	24 V dc	
Efficiency (Normal Mode) - Battery Fully Charged	>95%	>95%
Efficiency (BATTERY Mode) - Battery Fully Charged	>93%	>93%
INPUT		
Nominal Input Voltage	24V	
Input Voltage Range	22.1 – 28.6 V dc	
Contact Relay	50Vdc, 0.2A	50Vdc, 0.2A
OUTPUT		
Nominal Output Voltage	24 V dc	
Output Voltage Range	Ubat range: 22.1 – 28.6 Vdc maximum Worst case: Ubat - 0.4 V DC = Uout	
Output Ripple(Normal Mode) Fully Charged	Uin Ripple = Uout Ripple	
Rated Output Current	10 A	20 A
Rated Output Power	240W	480W
PROTECTION		
Input Current Protection (Normal Mode)	Internally Fused 30A 32VDC	
Peak current capability (Normal Mode)	Power boost (allows for 150% of rated load) for > 4 seconds	
Reverse Polarity, input voltage	UPS goes to battery mode	
Reverse Polarity, battery input	UPS does not turn on	
Output Short Circuit	UPS shutdown, Auto-recovery	
Battery Over Voltage Protection	Charging stops at 28V, Auto-recovery	
Input Protection	Allowable Input range is 21.6V min and 28.6V max. or else UPS goes to Battery Mode	
Back EMF Immunity, output	< 35 V Max No damage, Auto-recovery	
Overtemperature Protections	Unit shutdown, Auto-recovery	
WEIGHT & DIMENSIONS		
Net Weight	0.88 lb. (0.4 kg)	
H x W x D	4.88 in. x 1.37 in. x 4.80 in. (124 mm x 35 mm x 121.9 mm)	

Table 12

Power Module Specifications		
Parameter	Catalog Number	
	SDU 10-24B	SDU 20-24B
ENVIRONMENT		
Audible Noise	<40 dBA (1 m) distance	
Operating Temperature	Ordinary Location: -15°C to +50°C	
	Hazardous Location: -15°C to +40°C	
Storage Temperature	-40°C to +85°C	
Humidity	0 to 95%, non-condensing	
Pollution	Degree 2	
Maximum Elevation	3000m max	
Shock	According to IEC60068-2-27	
Vibration	According to IEC60068-2-6	
GENERAL		
MTBF	>1,000,000 hours; Telcordia SR-332 @ 40C	
Life Expectancy	>15 yrs. 50% load at 40C	
	>15 yrs. 100% load at 25C	
INSTALLATION		
Power Input/Output Terminals	Connector size range: 10-14 AWG (5.3-2.1 mm ²) for solid/stranded conductors. Screw Torque: 4.4 -6.5 lb-in (50-73 N-cm)	
Battery Terminals	Polarized Terminal Connections for the Battery (+Red color, - Black color) The maximum length of the connection between the power module and battery module is 6 ft. (1.85m).	
Relay Contact Terminals	Use connector size range: 24 – 16 AWG (0.34 – 4mm ²)	
Mounting	Use DIN TS35/7.5 or TS35/15 rail system. Apply to both thin and thick DIN Rail (1.0 and 1.5mm), optional screw mounting set SDU-PMBRK.	

Table 12

Power Module Specifications		
Parameter	Catalog Number	
	SDU 10-24B	SDU 20-24B
SAFETY CERTIFICATIONS		
SDU DC UPS System*	<p>Hazardous Locations (except SDU 24-BATEM): cULus Recognized - UL121201/CSA 213 Class I, Division 2 Groups A B C D T4, UL/CSA 60079-0, UL/CSA 60079-7, UL/CSA 60079-15 Class I, Zone 2, Groups IIC</p> <p>UKCA and CE Ex Certified: EN IEC 60079-0, EN IEC 60079-7, EN IEC 60079-15</p> <p>SDU 10-24B, SDU 20-24B - II 3 G Ex ec nC IIC T4 Gc, UL 22 ATEX 2553X, UL22UKEX2393X</p> <p>SDU 24-BATB - II 3 G Ex ec IIC T4 Gc, UL 22 ATEX 2553X, UL22UKEX2393X</p> <p>cULus Listed: UL/CSA 61010-1, UL/CSA 61010-2-201</p> <p>cRUus: UL Recognized Component UL/CSA 62368-1, UL/CSA 60950-1</p> <p>CE LVD / UKCA EE (Safety) Regulations 2016 –IEC/EN 62368-1, IEC/EN 61010-1, IEC/EN 61010-2-201 (CB Certified IEC/EN 60950-1)</p> <p>CE/UKCA EMC - EN 62040-2 Category C2, EN 55032, EN 55011, EN 55035, EN 61000-6-1, EN 61000-6-2, EN 61000-6-3, EN 61000-6-4, EN 61326-1, EN61000-3-2, EN 61000-3-3</p> <p>See Note 1 below- UL Recognized UL121201/CSA 213 Class I, Division 2 Groups A B C D T4</p> <p>See Note 1 below- ATEX/UKCA – EN IEC 60079-0, EN IEC 60079-7, EN IEC 60079-15</p> <p>Models SDU 10-24B, SDU 20-24B - II 3 G Ex ec nC IIC T4 Gc</p> <p>Model SDU 24-BATB - II 3 G Ex ec IIC T4 Gc</p>	
<p>*The SDU DC UPS system includes a power module (SDU 10-24B or SDU 20-24B) and a battery module (SDU 24-BATB or SDU 24-BATEM).</p>		

Note 1-

 **WARNING - Risk of explosion.**

The SDU 24-BATEM has not been evaluated for use in any hazardous location and cannot be installed in a Class I, Div 2 or Class I, Zone 2 hazardous location. Do not install in a hazardous location!

Table 13

Battery Module Specifications

Parameter	Catalog Number	
	SDU 24-BATB	SDU 24-BATEM (see Note 1 below)
Nominal Voltage	24 V dc	
Protection	Fuse: 30 A	Circuit Breaker: 24 V, 25 A
Charging Current	1.2 A	
Battery Type	Sealed, maintenance-free lead acid batteries	
Enclosure Type	IP20	NEMA 1
Terminal Connector Type	Polarized power pole connectors	
Operating Temperature	Ordinary Location: -15°C to +50°C	
	Class I, Div 2/ Zone 2 Hazardous Location: -15°C to +40°C	N/A Not for use in a hazardous location.
Storage Temperature	-15°C to +40°C	
Humidity	95%, non-condensing	
Typical Recharge Time (to 90% of full capacity)	SDU 24-BATB: 6 hours for 2 battery modules; 3 hours for each additional battery module SDU 24-BATEM: 8 hours for 1 battery module	
Backup Times	See Tables 5–8	
Weight	11.46 lb. (5.2 kg)	16 lb. (7.26 kg)
Enclosure Dimensions	7.57 in. x 4.85 in. x 4.33 in. (192.4 mm x 123.3 mm x 110 mm)	11.50 in. x 5.57 in. x 4.57 in. (292 mm x 142 mm x 116 mm)
Mounting	Simple snap-on system for DIN rail TS35/7.5 or TS35/15 or optional chassis mounting brackets (P/N: SDU-PMBRK)	Chassis mounting brackets (P/N: SDU-PMBRK)
Accessories	1 ft (30.5cm) polarized battery cable	6 ft (180cm) polarized battery cable
*The SDU DC UPS B-Series system includes a power module (SDU 10-24B or SDU 20-24B) and a battery module (SDU 24-BATB or SDU 24-BATEM).		

Note 1-** WARNING - Risk of explosion.**

The SDU 24-BATEM has not been evaluated for use in any hazardous location and cannot be installed in a Class I, Div 2 or Class I, Zone 2 hazardous location. Do not install in a hazardous location!

Troubleshooting

Table 14

Troubleshooting		
Problem	Probable Cause	Required Action
UPS has no output	Remote ON/OFF terminals (R1 and R2) are not short circuited.	Insert REMOTE ON/OFF BYPASS jumper to short circuit the terminals.
	Input DC voltage is not within the acceptable range of 22.1V – 28.6V and the battery is drained.	Check the DC input voltage. If the input is within the range, check the input fuse.
	Load is short circuited	Remove the load.
	Other failure.	Contact Technical Support.
UPS cannot turn ON at Normal Mode	Loose input DC voltage power connection.	Tighten the dc input power connection.
	Input DC voltage is not within the acceptable range of 22.1V – 28.6V.	Adjust dc input voltage
	Other failure.	Contact Technical Support.
UPS cannot turn ON at Battery Mode	Battery is Drained or not connected	Connect or recharge battery.
Backup time is too short	Battery is not fully charged.	Recharge the UPS for at least three (3) hours.
	Battery has low capacity due to deterioration	Replace the battery
	Other failure.	Contact Technical Support.
Display Steady Red at Battery LED	Battery is drained	Recharge the battery for at least three (3) hours.
	Battery is disconnected.	Check battery connections.
	Other battery failure.	Replace the battery.
SOLAHD Technical Support		
For further assistance, please contact SolaHD Technical Support at 1.800.377.4384/1.847.268.6651 or by e-mail at solahd.technicalservices@emerson.com .		

Storage

Extended Storage

- Store the UPS covered and upright in a cool, dry location with the battery fully charged.
- Remove the REMOTE ON/OFF Bypass Jumper (or turn remote ON/OFF Switch to OFF position). Remove any accessories in the accessory slot and disconnect any cables connected to the computer interface port to avoid unnecessary draining of the battery.
- During extended storage in environments where the ambient temperature is -15°C to +30°C (+5°F to +86°F), charge the UPS battery every 4 months.
- During extended storage in environments where the ambient temperature is +30°C to +45°C (+86°F to +113°F), charge the UPS battery every three (3) months.

The information in this manual is provided as a guide for installation, operation, and maintenance. It does not affect or exceed our obligations under the Terms and Conditions of Sale.

Note that unit specifications are subject to change without notice.

Technical Support

Website: www.solahd.com

Technical Support E-Mail: solahd.technicalservices@emerson.com

Toll-Free: (800) 377-4384

USA: (847) 268-6651

Warranty

Warranty Information

Please refer to the “Terms & Conditions of Sale” at <https://www.appleton.emerson.com/documents/appleton-grp-llc-terms-of-sale-policies-procedures-en-us-7444090.pdf>

Product Literature

For additional product literature, including French and Spanish manuals, please visit www.solahd.com.

While every precaution has been taken to ensure accuracy and completeness in this manual, Appleton Grp LLC d/b/a Appleton Group assumes no responsibility, and disclaims all liability for damages resulting from use of this information or for any errors or omissions.

The Emerson logo is a trademark and service mark of Emerson Electric Co.
Appleton Grp LLC d/b/a Appleton Group. SolaHD is a registered trademark of Appleton Grp LLC.
All other marks are the property of their respective owners. © 2022 Emerson Electric Co. All rights reserved.

**United States
(Headquarters)**

Appleton Grp LLC
9377 W. Higgins Road
Rosemont, IL 60018
United States
T +1 800 621 1506

Australia Sales Office

Bayswater, Victoria
T +61 3 9721 0387

Korea Sales Office

Seoul
T +82 2 3483 1555

Europe

ATX SAS
Espace Industriel Nord
35, rue André Durouchez,
CS 98017
80084 Amiens Cedex 2
France
T +33 3 2254 1390

China Sales Office

Shanghai
T +86 21 3338 7000

Canada

EGS Electrical Group Canada
Ltd.
99 Union Street
Elmira ON, N3B 3L7
Canada
T +1 888 765 2226

Middle East Sales Office

Dammam, Saudi Arabia
T +966 13 510 3702

Asia Pacific

EGS Private Ltd.
Block 4008, Ang Mo Kio
Ave 10,
#04-16 TechPlace 1,
Singapore 569625
T +65 6556 1100

Chile Sales Office

Las Condes
T +56 2928 4819

Latin America

EGS Comercializadora
Mexico S de RL de CV
Calle 10 N°145 Piso 3
Col. San Pedro de los Pinos
Del. Álvaro Obregon
Ciudad de México. 01180
T +52 55 5809 5049

India Sales Office

Chennai
T +91 44 3919 7300