

Operator's Manual



optris® BR 500

Calibration source

Optris GmbH & Co. KG
Ferdinand-Buisson-Str. 14
13127 Berlin
Germany

Tel.: +49 30 500 197-0
Fax: +49 30 500 197-10

E-mail: info@optris.com
Website: www.optris.com



Table of Contents

Table of Contents	3
1 General Information	6
1.1 Overview.....	6
1.2 Warranty	7
1.3 Scope of supply	8
1.4 Maintenance	8
2 Safety	9
2.1 ⚠ Safety Warning.....	9
2.2 ⚠ Risk of Burns	10
2.3 ⚠ Electrical Hazards	11
2.4 Safety Precautions	11
2.5 Preventive Measures.....	12

3	Description of the Calibration Source	13
4	Operating Specifications.....	14
5	Operation	16
5.1	Installation	16
5.2	Set the temperature.....	16
5.3	Calibration Completion.....	17
5.4	Recommendations for operation	17
6	Basics of Infrared Thermometry.....	18
7	Emissivity	19
7.1	Definition.....	19
7.2	Determination of unknown emissivity.....	19
7.3	Characteristic emissivity.....	20
8	Calibration of Infrared Thermometers [1] [2]	21
8.1	Transfer standard.....	23

8.2	ITS-90.....	24
8.3	Calibration Geometry	26
8.4	Calibration	29
Appendix A – Declaration of Conformity		31
Appendix B – Literature		32

1 General Information

1.1 Overview

Thank you for choosing the **optris® BR 500** calibration source.

The BR 500 is a rugged calibration source and can be used for calibration and inspection of infrared thermometers and thermal imagers.

The instrument comprises a large-diameter infrared radiator with a high-emissivity coating (Eps=0.95) and a precise microcomputer temperature control system. It features an advanced color touch screen interface for easy operation. The actual temperature of the infrared radiation surface is continuously displayed on the screen as **PV** (Process Value). The display has a resolution of 0.1 ° for the full range of up to 500.0 °C / 932.0 °F. For higher precision, the resolution can be set to 0.01 ° for a reduced range of 300.00 °C / 573.00 °F.

The product is available for operation with 220 V / 50 Hz or 110 V / 60 Hz power supplies. The operation is simple and intuitive. For automated testing, a programmable set-point **SV** can be configured to perform sequential temperature control operations.

The following abbreviations are used in this document:

- SV (Set Value / Setpoint) → desired temperature
- PV (Process Value) → measured temperature
- MV (Manipulated Variable) → controller output (e.g. % heating power)



To avoid damaging the special high-emissivity coating, do not touch the radiation surface with sharp or pointed objects.



Read this manual carefully before initial start-up. The manufacturer reserves the right to change specifications as part of continuous product improvement.



The optris® BR 500 is not designed for continuous operation. Maximum daily use is 8-10 hours. Long-term operation at the maximum temperature of 500 °C is not recommended.

1.2 Warranty

Every product passes through a quality process. Nevertheless, if failures occur, contact customer service immediately. The warranty period covers 24 months starting on the delivery date. After the warranty has expired the manufacturer guarantees additional 6 months' warranty for all repaired or substituted product components. Warranty does not apply to damages, which result from misuse or neglect. The warranty also expires if the product has been opened. The manufacturer is not liable for consequential damage or in case of non-intended use of the product.

If failure occurs during the warranty period the product will be replaced, calibrated or repaired without further charges. The freight costs are covered by the sender. The manufacturer reserves the right to exchange components of the product instead of repairing it. If the failure results from misuse or neglect the user must pay for the repair. In that case you may ask for a cost estimate beforehand.

All systems undergo an extensive end-of-line test before delivery. This final quality control ensures that every product meets our strict performance and reliability standards. By rigorously testing each unit, we guarantee accurate and reliable operation in accordance with its specifications.

1.3 Scope of supply

- BR 500 calibration source
- Power supply cable
- Calibration certificate
- Quick Start Guide

To ensure the documentation remains current and to minimize environmental impact, this manual is not supplied in printed form. Please download the latest version from our website.

The serial number is located at the back of the unit. Please reference this number in all correspondence with customer service regarding maintenance, spare parts, or repairs.

1.4 Maintenance

Cleaning the housing: The exterior housing should be cleaned with a soft, damp cloth using water or a mild, non-abrasive cleaning agent.



- Never use cleaning compounds containing solvents.
- The device must only be cleaned when it is switched off and has completely cooled down.

2 Safety

This instrument must be used strictly in accordance with the instructions in this manual. Failure to do so may result in damage to the instrument or personal injury.

2.1 Safety Warning

To avoid personal injury, follow the safety guidelines:

- **Intended Use:** Use this instrument for calibration purposes only. Do not use it for any other application or in a manner that could create unforeseen hazards.
- **Operating Environment:** This instrument is designed for indoor use only.
- **Operator Requirements:** Operation of this instrument is restricted to qualified personnel who have fully read and understood all safety instructions provided in this manual.
- **Preparation Before Use:** Before first use, after transport, after prolonged storage, or if the power has been off for more than 10 days, power on the instrument and allow it to warm up for 2 hours. This ensures it meets all safety requirements of IEC 61010-1. If the instrument has been exposed to moisture, allow it to dry for at least 4 hours before use.
- **Placement and Clearance:** Ensure the environment allows for proper ventilation. The top of the instrument must have at least 1 meter of clearance, and at least 15 cm of clearance is required on all sides.
- **Inspect Before Use:** Do not use the instrument if it shows any signs of internal or external damage.
- **Avoid Radiant Heat Damage:** Do not place the instrument near walls or other objects, as the high operating temperature can cause radiant heat damage.

- **Fire Safety:** Keep the instrument away from combustible materials to prevent fire hazards.
- **Environmental Limits:** Do not operate the instrument outside the environmental conditions specified in this manual.
- **High-Temperature Operation:** When operating at high temperatures, assign a dedicated person to monitor the process closely.
- **Malfunction Procedure:** If you observe any abnormal conditions during operation, stop using the instrument immediately. Do not resume use until it has been inspected, serviced, and confirmed to be in normal working condition.

2.2 Risk of Burns

- **Surface Temperature:** Do not touch the surface of the infrared source or the surrounding metal area. The temperature of the infrared radiation source is the same as the actual temperature shown on the display.
- **Safe Shutdown Procedure:** To prevent hazardous conditions, the device must not be switched off while the surface temperature of the infrared source is above 100 °C (212 °F). Allow the instrument to cool down before shutdown. Power may only be switched off once the surface temperature has decreased below 40 °C (104 °F), as indicated by the Process Value (PV).
- **Proper Positioning:** The instrument must be positioned on a stable, horizontal surface, regardless of whether the heating surface is oriented perpendicular to the horizontal plane.
- **High-Temperature Operation (Above 300 °C / 572 °F):** At these temperatures, additional precautions are required to prevent burns and fire hazards. Ensure that unauthorized personnel are kept away from the equipment and the surrounding area.

2.3 ⚠ Electrical Hazards

- **Grounding Requirements:** The instrument is supplied with a three-pin grounding plug power cord. It must only be connected to a three-pin power socket that is reliably grounded and complies with all applicable wiring regulations.
- **Operation Without Grounding:** Never connect or operate the instrument without a properly grounded and wired socket.
- **High Voltage Hazard:** High voltages are present during instrument operation. Failure to follow all safety precautions can result in serious injury or death.
- **Access to the interior is not permitted:** The instrument housing must not be opened. In case of technical issues, contact customer service.
- **Fuse Replacement:** Always turn off the power and disconnect the power cord before replacing the fuse.
- **Power Cord Replacement:** If the power cord requires replacement, it must be replaced with a cord of the correct power rating and identical specification.

2.4 Safety Precautions

- When the instrument is not in operation, use the protective cover to shield the infrared radiation surface.
- Do not move the instrument while it is powered on.
- Do not move the instrument when the temperature of the infrared radiation surface exceeds 50 °C / 122 °F.
- Do not touch the infrared radiation surface when the temperature exceeds 50 °C / 122 °F. Oils and salts from the skin can permanently damage the surface and affect measurement accuracy.

- Do not clean the infrared radiation surface using liquids or compressed air, as this may damage the surface and impair measurement accuracy.
- Do not use liquids or gases to cool the infrared radiation surface. This may cause permanent damage and significantly affect measurement accuracy.

2.5 Preventive Measures

- Ensure that the local power supply voltage matches the specified operating voltage before purchase and use.
- Do not modify the factory-set calibration constants. These parameters may only be adjusted by qualified and authorized personnel, as correct settings are essential for safe and proper operation.
- Always keep the instrument in an upright position during handling and transport.

3 Description of the Calibration Source

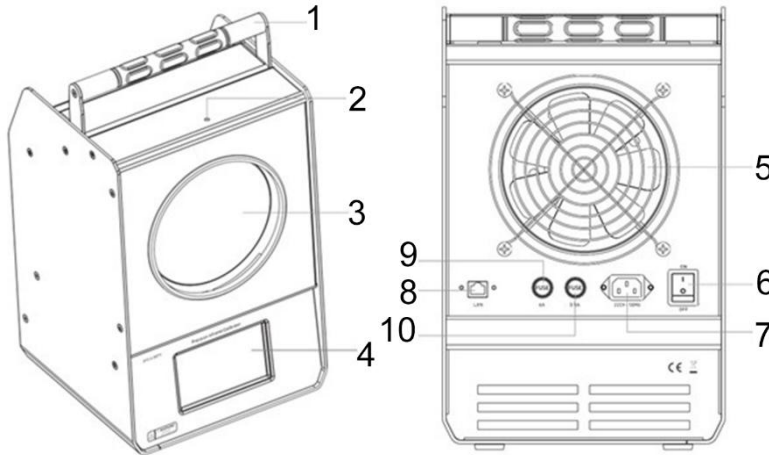

1. Handle
2. Temperature Detection Hole
3. Infrared Radiation Surface
4. Touch Screen
5. Ventilating Fan
6. Power Switch
7. Power Input Socket
8. Ethernet Communication Port
9. 6 A Fuse
10. 0.5 A Fuse

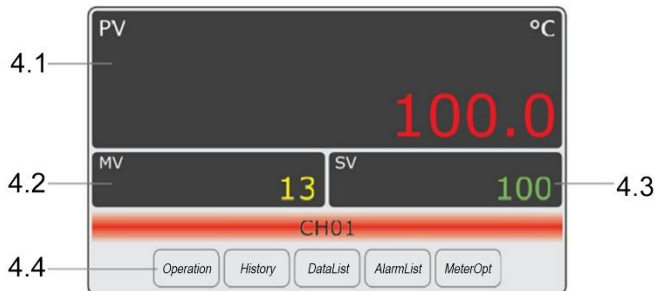

- 4.1 PV Value
- 4.2 MV Value
- 4.3 SV Value
- 4.4 Control Key

4 Operating Specifications

Display Resolution	0.1 at Range 500 °C / 932 °F
	0.01 at Range 300 °C / 572 °F
Display Accuracy¹⁾ (Test ambient temperature 15 to 25 °C / 59 to 77 °F, stable temperature, no wind around)	± 0.35 °C / 0.70 °F at 35 °C / 95 °F
	± 0.50 °C / 1.00 °F at 100 °C / 212 °F
	± 0.70 °C / 1.40 °F at 200 °C / 392 °F
	± 1.50 °C / 3.00 °F at 350 °C / 662 °F
	± 1.9 °C / 3.8 °F at 500 °C / 932 °F
Stability	± 0.05 °C / 0.10 °F at 35 °C / 95 °F
	± 0.20 °C / 0.40 °F at 250 °C / 482 °F
	± 0.4 °C / 0.8 °F at 500 °C / 932 °F
Surface Temperature Consistency (Target Center Diameter 125mm)	± 0.20 °C / 0.40 °F at 35 °C / 95 °F
	± 0.80 °C / 1.60 °F at 250 °C / 482 °F
	± 1.3 °C / 2.6 °F at 500 °C / 932 °F
Surface Temperature Consistency (Target Center Diameter 50mm)	± 0.20 °C / 0.40 °F at 35 °C / 95 °F
	± 0.50 °C / 1.00 °F at 250 °C / 482 °F
	± 1.0 °C / 2.0 °F at 500 °C / 932 °F
Heating Time	20 minutes (35 to 450 °C / 95 to 842 °F)
	10 minutes (450 to 500 °C / 842 to 932 °F)
Cooling Time	40 minutes (500 to 100 °C / 932 to 212 °F)

	40 minutes (100 to 35 °C / 212 to 95 °F)
Temperature Stabilization Time	Less than 10 minutes
Fixed Emissivity	0.95
Target Diameter	152mm
Computer Interface	Ethernet Wireless Port
Power Supply	220 V AC 50 Hz or 110V AC 60 Hz, plus or minus 10 %, 1000 W (Select a fixed voltage)
Fuse	220 V AC choose, 6 A (Heating), 0.5 A (Control)
Size/Weight	380 x 240 x 230 mm / 9.8 kg
Safety Compliance	IEC61010-1, IEC1010-2-010 and CAN / CSA22.2 No. 61010-1-04
Ambient Temperature Range	5 to 30 °C / 41 to 86 °F
Environmental Relative Humidity	Maximum 80 % RH
Rated Power Voltage	Within ± 10 %
Altitude	Below 2000 m

1) For IR thermometers with a spectral sensitivity of 8 – 14 μm and an emission factor between 0.9 and 1.0.



The controller parameters are factory-set to ensure optimal performance and safe operation of the blackbody calibration source. Do not modify these settings, as this will void the warranty.



Use the calibrator in a stable, vibration-free, clean laboratory-type environment to ensure accurate and reliable measurements.

For accurate determination of the radiative temperature of the calibration source, the use of a reference infrared thermometer (e.g. Optris CTlaser DCI) is recommended. ► **8 Calibration of Infrared Thermometers** [1] [2]

5 Operation

5.1 Installation

Place the BR 500 on a laboratory bench or any other suitable, flat, and stable surface. Connect the power cord and ensure that the supply voltage matches the specified requirements. Set the power switch on the rear panel to '**ON**'.

WARNING: Risk of unexpected high temperatures. Upon restart, the device automatically heats to the last set temperature prior to shutdown.

5.2 Set the temperature

The Process Value (PV) represents the current surface temperature of the infrared calibrator radiator. The Setpoint Value (SV) defines the desired temperature. The Manipulated Variable (MV) indicates the current controller output as a percentage.

Five buttons are located at the bottom of the screen. First, press '**Operation**', then select '**SV**' and enter the desired temperature using the numeric keypad. Confirm the new setpoint and return to the previous menu. Next, select '**Auto**', then press '**Run**' to apply the settings. Press '**Panel**' to return to the main screen or '**History**' to view the temperature trend.

The infrared calibrator automatically controls the radiator surface temperature to reach the setpoint within the specified time.

5.3 Calibration Completion

After completing the test, reduce the setpoint (SV) to below 40 °C / 104 °F and allow the infrared calibrator radiator to cool down gradually. Do not switch off the power until the temperature has fallen below 40 °C / 104 °F.

WARNING: Switching off the device at high temperatures may cause damage to the infrared calibrator and poses a burn risk.

5.4 Recommendations for operation

For accurate verification or calibration of infrared thermometers, it is essential that the calibration source has reached a stable thermal state. Therefore, always observe the specified heating time of the BR 500.

► 4 Operating Specification

When verifying or calibrating infrared thermometers, ensure proper consideration of the optical field of view (D:S ratio) and the calibration geometry, particularly the distance to the blackbody source. For detailed information, consult Optris. ► **8 Calibration of Infrared Thermometers** [1] [2]

Important: Depending on the selected temperature, the housing of the BR 500 may become warm or hot. Do not place any materials or objects on the radiator housing. The ventilation outlet on the rear side and the radiation aperture on the front must remain unobstructed at all times.

6 Basics of Infrared Thermometry

Depending on the temperature each object emits a certain amount of infrared radiation. A change in the temperature of the object is accompanied by a change in the intensity of the radiation. For the measurement of “thermal radiation” infrared thermometry uses a wavelength ranging between 1 μm and 20 μm .

The intensity of the emitted radiation depends on the material. This material contingent constant is described with the help of the emissivity which is a known value for most materials (► **7 Emissivity**).

Infrared thermometers are optoelectronic sensors. They calculate the surface temperature based on the emitted infrared radiation from an object. The most important feature of infrared thermometers is that they enable the user to measure objects contactless. Consequently, these products help to measure the temperature of inaccessible or moving objects without difficulties. Infrared thermometers basically consist of the following components:

- Lens
- Spectral filter
- Detector
- Electronics (amplifier/ linearization/ signal processing)

The specifications of the lens decisively determine the optical path of the infrared thermometer, which is characterized by the ratio Distance to Spot size.

The spectral filter selects the wavelength relevant for the temperature measurement. The detector in combination with the processing electronics transforms the emitted infrared radiation into electrical signals.

7 Emissivity

7.1 Definition

The intensity of infrared radiation, which is emitted by each body, depends on the temperature as well as on the radiation features of the surface material of the measuring object. The emissivity (ϵ – Epsilon) is used as a material constant factor to describe the ability of the body to emit infrared energy. It can range between 0 and 100 %. A “blackbody” is the ideal radiation source with an emissivity of 1.0 whereas a mirror shows an emissivity of 0.1.

If the emissivity chosen is too high, the infrared thermometer may display a temperature value which is much lower than the real temperature – assuming the measuring object is warmer than its surroundings. A low emissivity (reflective surfaces) carries the risk of inaccurate measuring results by interfering infrared radiation emitted by background objects (flames, heating systems, chamottes). To minimize measuring errors in such cases, the handling should be performed very carefully and the unit should be protected against reflecting radiation sources.

7.2 Determination of unknown emissivity

- ▶ First, determine the actual temperature of the measuring object with a thermocouple or contact sensor. Second, measure the temperature with the infrared thermometer and modify the emissivity until the displayed result corresponds to the actual temperature.
- ▶ If you monitor temperatures of up to 380 °C you may place a special plastic sticker (emissivity dots – part number: ACLSED) onto the measuring object, which covers it completely. Now set the emissivity to 0,95

and take the temperature of the sticker. Afterwards, determine the temperature of the adjacent area on the measuring object and adjust the emissivity according to the value of the temperature of the sticker.

- ▶ Cover a part of the surface of the measuring object with a black, flat paint with an emissivity of 0.98. Adjust the emissivity of your infrared thermometer to 0.98 and take the temperature of the colored surface. Afterwards, determine the temperature of a directly adjacent area and modify the emissivity until the measured value corresponds to the temperature of the colored surface.

CAUTION: On all three methods the object temperature must be different from ambient temperature.

7.3 Characteristic emissivity

In case none of the methods mentioned above help to determine the emissivity you may use emissivity tables. These are average values, only. The actual emissivity of a material depends on the following factors:

- Temperature
- Measuring angle
- Geometry of the surface
- Thickness of the material
- Constitution of the surface (polished, oxidized, rough, sandblast)
- Spectral range of the measurement
- Transmissivity (e.g. with thin films)

8 Calibration of Infrared Thermometers [1] [2]

In this chapter the general procedure and important relationships for the calibration of infrared thermometers are explained. For a detailed description of the different calibration methods and a detailed uncertainty consideration we recommend the standard VDI/ VDE 3511 part 4.3 Calibration of radiation thermometers.

Infrared thermometers are calibrated with the help of reference radiation sources, so called blackbodies. These radiation sources can produce different radiation temperatures with a high stability which are used to determine the calibration constants of the infrared thermometers. For the calibration process it is of essential importance to know the exact value of the radiation temperature. It can be measured either by using a contact thermometer (in combination with the determination of the emissivity) or by using a transfer standard infrared thermometer.

The emissivity of an ideal radiation source would be 1.00 for all wavelengths and emission angles. From all real existing sources cavity radiation sources are achieving the best results (emissivity values up to 0.999). The emissivity of a plate radiation source is strongly dependent on the surface properties and is typically at 0.96.

For the calibration method described here, knowledge of the exact emissivity of the radiation source is not required.

For the initial factory calibration Optris is defining the calibration temperatures in a way that all constants can be determined with the best possible accuracy. For a re-calibration by the user or a local calibration laboratory the calibration temperatures should be selected close to the temperatures of the specific application or, if not known, according to the rule:

- Low end of range +10 % of the infrared thermometer or room temperature
- Middle of the temperature range
- High end of range -10 %

8.1 Transfer standard

Optris is using a traceable transfer standard radiation thermometer (in the following text mentioned as CTlaser-PTB) to measure the radiation temperature of the reference source. As the CTlaser-PTB needs to be traceable to the ITS-90, the PTB (Physikalisch-Technische Bundesanstalt, the German national metrology institute) is calibrating this instrument in regular periods.



Reference IR thermometer CTlaser-DCI

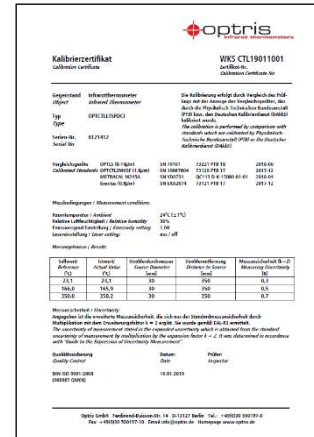

Certificate of calibration for CTlaser-DCI

The CTlaser-DCI is a reference IR thermometer which is based on the IR thermometer series optris CTlaser. The units are produced with pre-selected components supporting a high stability of measurement. In

combination with a dedicated calibration at several points the CTlaser-DCI achieves a higher accuracy than units out of the series production and is therefore qualified to be used as dedicated calibration instrument (DCI).

8.2 ITS-90

The 1990 International Temperature Scale (ITS-90) prescribes a system of measurement devices and methods that ensure a uniform temperature measurement worldwide. The ITS-90 is a very good approximation of the thermodynamic temperature. It is based on 17 well reproducible fixed points like melting points of highly pure metals.

The calibration process makes the measurement with an infrared thermometer traceable to ITS-90. To achieve this, the infrared thermometers are compared within a closed chain of comparative measurements with a known uncertainty with the national temperature standards from the PTB.

Fixed point	Temperature/ K	Temperature/ °C
Triple point of Mercury [Hg]	234,3156	-38,8344
Triple point of Water [H ₂ O]	273,16	0,01
Melting point of Gallium [Ga]	302,9146	29,7646
Melting point of Indium [In]	429,7485	156,5985
Melting point of Tin [Sn]	505,078	231,928
Melting point of Zinc [Zn]	692,677	419,527
Melting point of Aluminium [Al]	933,473	660,323
Melting point of Silver [Ag]	1234,93	961,78

Fixed points of the ITS-90 (Selection) [Source: www.its-90.com/ 12.01.2012]

For the calibration of the transfer standard radiation thermometers the PTB is using high-precision heat pipes. Due to different temperature stabilization procedures in combination with a high thermal mass of the cavities these heat pipes are reaching a high temperature stability of ± 10 mK.

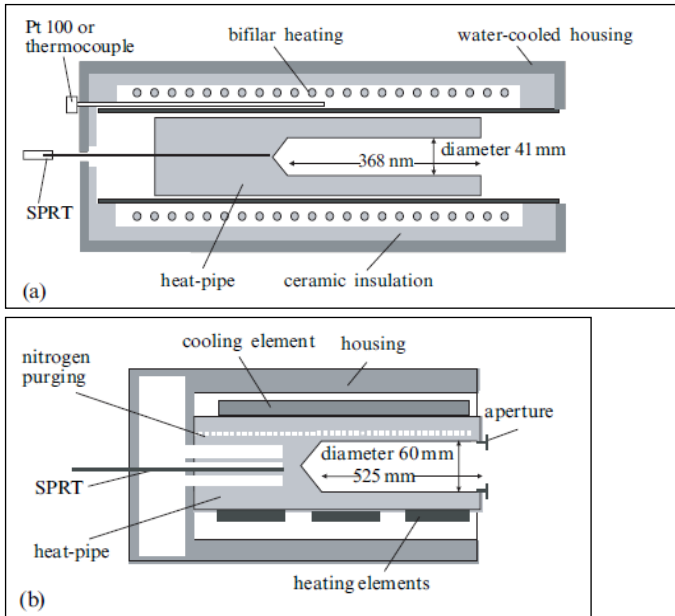

Schematic layout of heat pipes used at the PTB: sodium and caesium heat pipes (a) / water and ammonia heat pipes (b) [3]

8.3 Calibration Geometry

The optics of an IR thermometer is described by the distance to spot ratio (D:S). Depending on the quality of the optics a certain amount of radiation is also received from outside the specified measurement spot. The signal change in correlation with a resize of the radiation source is described by the Size-of-source effect (SSE).

The radiation maximum which the IR thermometer is receiving equals the radiation of a hemispheric radiation source. Therefore the value which is specified in datasheets and technical documentation as measurement spot is in general a certain defined percentage of this radiation maximum – values of 90 % or 95 % are common. Consequently all manufacturers of IR thermometers are using accurately defined geometries for the calibration of their units; means depending on the aperture of the radiation source (**A**) a distance (**a**) between the IR thermometer and the reference source is defined.

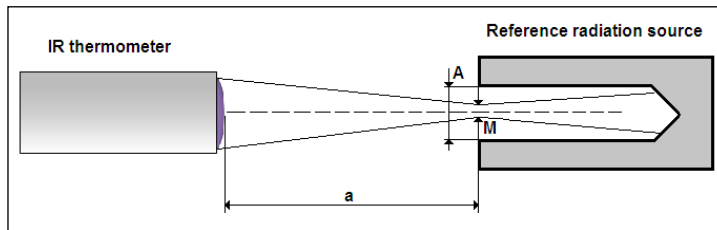

- | | |
|----------|---|
| A | Diameter of the effective area of the reference radiation source |
| M | Measurement spot of the IR thermometer at distance a |
| a | Measurement distance |

Calibration geometry

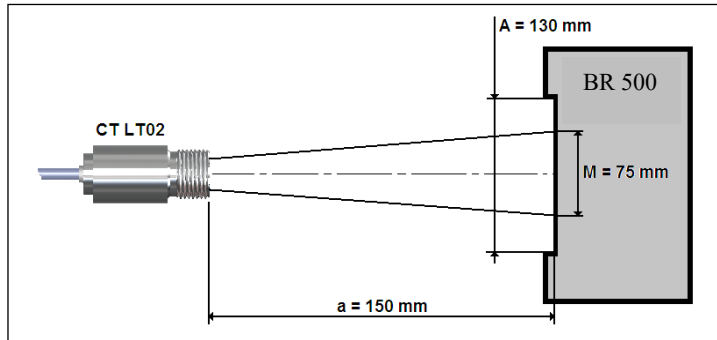

Example: Calibration geometry of the optris CTi LT02 on a BR 500 source

Calibration distances



Pyrometers	Radiation Source		Source Ø: 30 mm	Source Ø: 38 mm	Source Ø: 65 mm
	Model/ Optics	Calibration distances			
CS	TCLT15				150 mm
CSmicro	LT02				90 mm
	LT15				150 mm
	LT15H				150 mm
	LT22H				150 mm
	LT15HS				150 mm
	CF				150 mm
	2ML	60 mm			90 mm
	2MH	60 mm	110 mm		90 mm
	3ML				90 mm
	3MH				90 mm
	CF/CF1				90 mm
CX	LT22				150 mm
	LT15hs				150 mm
CT / CTex	LT02				90 mm
	LT15				150 mm
	LT22				150 mm
	LT15F				150 mm
	LT25F				150 mm
	CF				150 mm
	LT02H				90 mm
	LT10H				90 mm
	CF1				90 mm
	1ML	60 mm			90 mm
	2ML	60 mm			90 mm
	1MH	60 mm	110 mm		90 mm
	1MH1	60 mm	110 mm		90 mm
	2MH	60 mm	110 mm		90 mm
	2MH1	60 mm	110 mm		90 mm
	3ML				90 mm
	3MH				90 mm

Calibration geometries for Optris IR thermometers (selection – the complete list can be ordered or downloaded <https://optris.com/support-service/service/calibration/>)

8.4 Calibration

The basic requirements for a calibration laboratory are:

- Laboratory room with stable temperature and humidity
- Measurement equipment for air temperature and humidity
- Reference radiation source
- Traceable transfer standard radiation thermometer (e.g. CTlaser-PTB) or a dedicated calibration instrument (e.g. CTlaser-DCI)
- Adjustable holder for the infrared thermometer

For creating calibration certificates beside the laboratory temperature and humidity also the measurement distance and source diameter (calibration geometry) should be documented.

Calibration procedure:

Checking the optics of the CTlaser-PTB/ CTlaser-DCI and of the test unit – cleaning, if necessary

1. Switch on both units; consider warm-up time
2. Set the emissivity value to 1,00 on both units, if possible
3. Set the reference radiation source to a temperature which is significantly different to the internal temperature of the CTlaser-PTB/ CTlaser-DCI; wait for stabilization of the radiation source

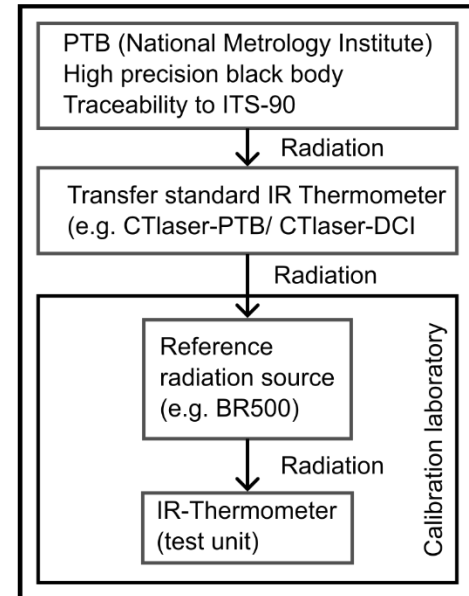

4. Bring the CTlaser-PTB/ CTlaser-DCI into measurement position ¹⁾ and determine the radiation temperature of the reference source
5. Bring the test unit into measurement position ¹⁾ and note the reading ²⁾
6. Set up the next radiation temperature; wait for stabilization of the source; repeat point 5 and 6

¹⁾ Determination of the measurement position:

- Put the unit at distance a centered to the aperture of the radiation source (for this purpose an adjustable aperture which is placed in front of the source can be helpful)
- Set the aperture to $0,9 \times$ measurement spot size
- Adjust the unit to the center of the aperture via maximum search
- After this please open the aperture to 100 % of the calibration geometry or remove it

²⁾ On portable IR thermometers reading stands for the shown temperature on the display. For online IR thermometers the signal at the analog output has to be measured. The function $T_{Rad} = f(\text{signal})$ must be known.

Appendix A – Declaration of Conformity

EG-Konformitätserklärung EU Declaration of Conformity



Wir / We

Optris GmbH
Ferdinand Buisson Str. 14
D-13127 Berlin

erklären in alleiniger Verantwortung, dass
declare on our own responsibility that

das Produkt BR 500
the product BR 500

den Anforderungen der EMV-Richtlinie 2014/30/EU und der Niederspannungsrichtlinie 2014/35/EU entspricht.

meets the provisions of the EMC Directive 2014/30/EU and the Low Voltage Directive 2014/35/EU.

Angewandte harmonisierte Normen:
Applied harmonized standards:

EMV-Anforderungen / EMC General Requirements:

EN 61326-1:2021 (Grundlegende Prüfanforderungen / Basic requirements)
EN 61326-2-3:2021

Gerätesicherheit von Messgeräten / Safety of measurement devices:

EN 61010-1:2010/A1:2019/AC:2019-04
EN 60825-1:2014 + AC:2017 + A11:2021 + A11:2021/AC:2022 (Lasersicherheit / Laser safety)

Beschränkung gefährlicher Stoffe / Restriction of hazardous substances:

EN IEC 63000:2018

Dieses Produkt erfüllt die Vorschriften der Richtlinie 2015/863/EU (RoHS) des Europäischen Parlaments und des Rates vom 4. Juni 2015 zur Beschränkung der Verwendung bestimmter gefährlicher Stoffe in Elektro- und Elektronikgeräten.

This product is in conformity with Directive 2015/863/EU (RoHS) of the European Parliament and of the Council of 4 June 2015 on the restriction of the use of certain hazardous substances in electrical and electronic equipment.

Berlin, 31.03.2026
Ort, Datum / place, date

Dr. Ulrich Krenitz
Geschäftsführer / General Manager

Appendix B – Literature

- [1] VDI/ VDE Standard: Temperature measurement in industry – Specification for radiation thermometers, 2001, VDI/ VDE 3511, Part 4.1
- [2] VDI/ VDE Standard: Temperature measurement in industry, Radiation thermometry – Calibration of radiation thermometers, 2004, VDI/ VDE 3511, Part 4.3
- [3] Jörg Hollandt, Rüdiger Friedrich, Berndt Gutschwager, Dieter R Taubert, Jürgen Hartmann – High-accuracy radiation thermometry at the National Metrology Institute of Germany, the PTB;
Published in: High Temperatures - High Pressures, 2003/2004, volume 35/36, pages 379 – 415

optris BR500-MA-E2026-03-C