

High resolution Bottom up glass inspection system for process control in glass tempering machines



Features

- Compact bottom up system for coating independent underneath measurement
- Excellent 1600 px resolution on maximum 4.3 m (14.11 ft) scan width (@ 90 cm [2.95 ft] distance)
- Integrated ultra-fast glass breakage detection combined with Digitally controlled lens protection system (DCLP)
- No cooling or air purge requirement
- Glass area calculation
- Pre-assembled system for easy installation on glass tempering furnaces

Specification PI 640i G7

Optical resolution	640 x 480 pixels
Detector	FPA, uncooled (17 µm x 17 µm)
Spectral range	7.9 µm
Temperature ranges	150 °C ... 900 °C (302 °F ... 1652 °F) 200 °C ... 1500 °C (392 °F ... 2732 °F)
Sighting range	0 ... 250 °C (32 ... 482 °F)
Frame rate	32 Hz / 125 Hz @ 640 x 120 pixels
Optics (FOV)	90° x 66° FOV / f = 7.7 mm (f=0.3 in) or 60° x 45° FOV / f = 10.5 mm (f=0.4 in) max. FOV: 111° / 1600 pixels per scan line ¹⁾ 4.3 m scan width @ 90 cm (2.95 ft) distance
Thermal sensitivity (NETD) ²⁾	80 mK (at T _{obj} = 650 °C [1202 °F])
Accuracy	±2 °C or ±2 %, (±3.6 °F or ±2 %) whichever is greater
PC interface	USB 2.0 / USB to GigE (PoE) interface
Process interface (PIF), industrial	2x 0 – 10 V input, digital input (max. 24 V), 3x 0/4 – 20 mA output, 3x relays (0 – 30 V / 400 mA), fail-safe relay
Ambient temperature	0 °C ... 50 °C (32 °F... 122 °F)
Relative humidity	20–80 %, non-condensing
Enclosure (size / rating)	46 x 56 x 76 – 100 mm [1.8 x 2.2 x 2.99 – 3.93 in] (depending on lens + focus position) / IP 67 (NEMA)
Weight	269 - 340 g [9.49 - 11.99 oz] (depending on lens)
Vibration	IEC 60068-2-6 / -64
Shock	IEC 60068-2-27 (25 G and 50 G)

Specification glass breakage sensor CTlaser 4ML

Temperature range	0 °C ... 500 °C (32 °F ... 932 °F)
Spectral range	2.2 - 6 µm
Optical resolution (90 % energy)	30:1
System accuracy ³⁾ (at T _{Amb} 23 ±5 °C)	± (0.3% of reading +2 °C [3.6 °F])
Temperature resolution (NETD) ⁴⁾	120 mK
Exposure time	90 µs (90% signal)
Response time	300 µs (90% signal)
Emissivity/ Gain (adjustable via rogramming keys or software)	0.100 – 1.100
Environmental rating	IP 65 (NEMA-4)
Ambient temperature ⁵⁾	-20 °C (4 °F) ... 70 °C (158 °F), (sensing head: 50 °C [122 °F] with laser on) 0 °C (32 °F) ... 85 °C (185 °F), (electronics)
Vibration (sensor)	IEC 60068-2-6 / -64
Shock (sensor)	IEC 60068-2-27 (25 G and 50 G)
Weight	600 g (21.6 oz) (sensing head) 420 g (14.8 oz) (electronics)

1) With 90° optics and usage of a diagonal scan line; maximum pixel count based on two cameras without overlapping
2) Measurement of the noise equivalent temperature difference (NETD) according to VDI 5585 standard, method B; 650 °C (1202 °F) black body temperature, frame rate 20 Hz averaged
3) ε = 1, response time 1 s
4) At time constant 1 ms and T_{obj} = 50 °C (122 °F)
5) The functioning of the LCD display may be limited at ambient temperatures below 0 °C (32 °F)

Scope of supply Button Up GIS 640i G7

- 2x PI 640i G7 imager with 90° or 60° FOV
- 2x Industrial Process Interface
- CTlaser 4ML glass breakage sensor with USB interface
- 2x DCLP Shutter system with mounting brackets for imagers
- 2x USB Server Gigabit
- Control cabinet with cable set (10 m each) and remote control box
- Software package
- 100-230 V AC/ 24 V DC power supply for initial start-up



optris Bottom Up GIS 640i G7

Measurement principle

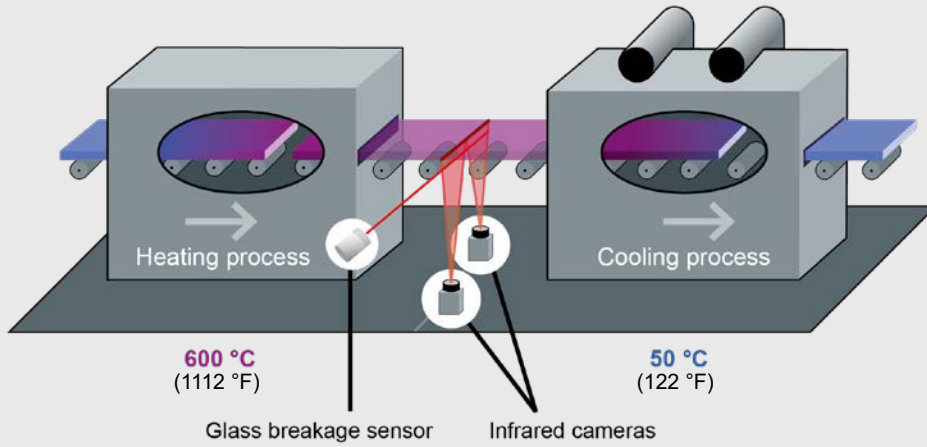

optris PI 640i G7
Infrared camera



optris CTlaser 4ML
Glass breakage sensor

System overview

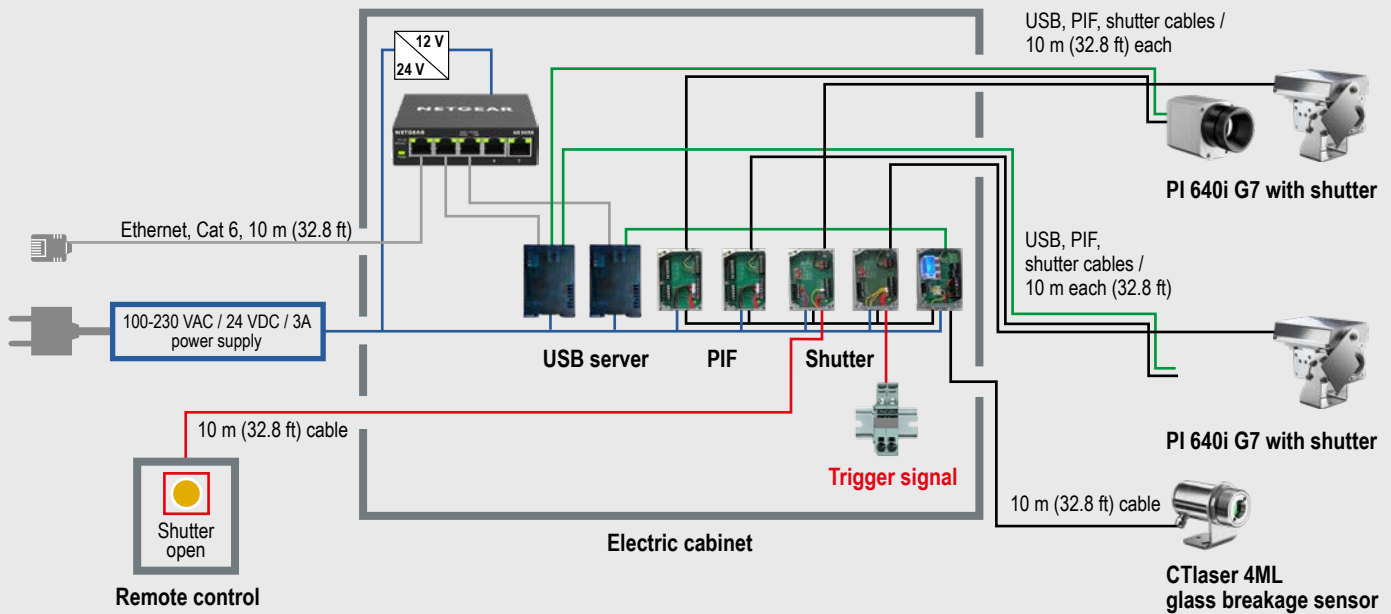

Software PIX Connect

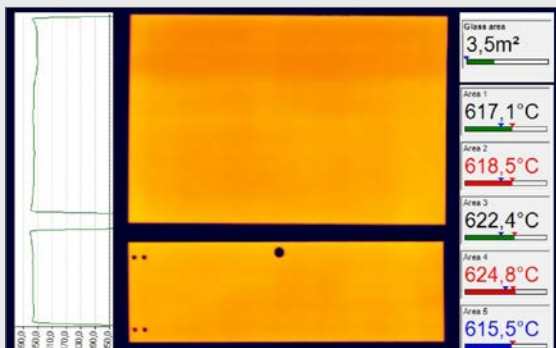

The software provides excellent image quality and manifold analysis features as profiles, measurement areas and alarm indication

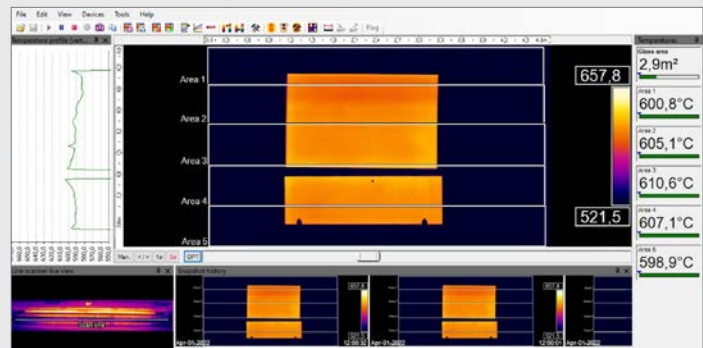

Exemplary software layout with thermal profile, IR live view, snapshot history, five measurement zones and glass area calculation