

Operating Instructions

iTHERM

MultiSens Flex TMS01

Modular direct contact TC and RTD multipoint thermometer for Oil & Gas and Petrochemical applications

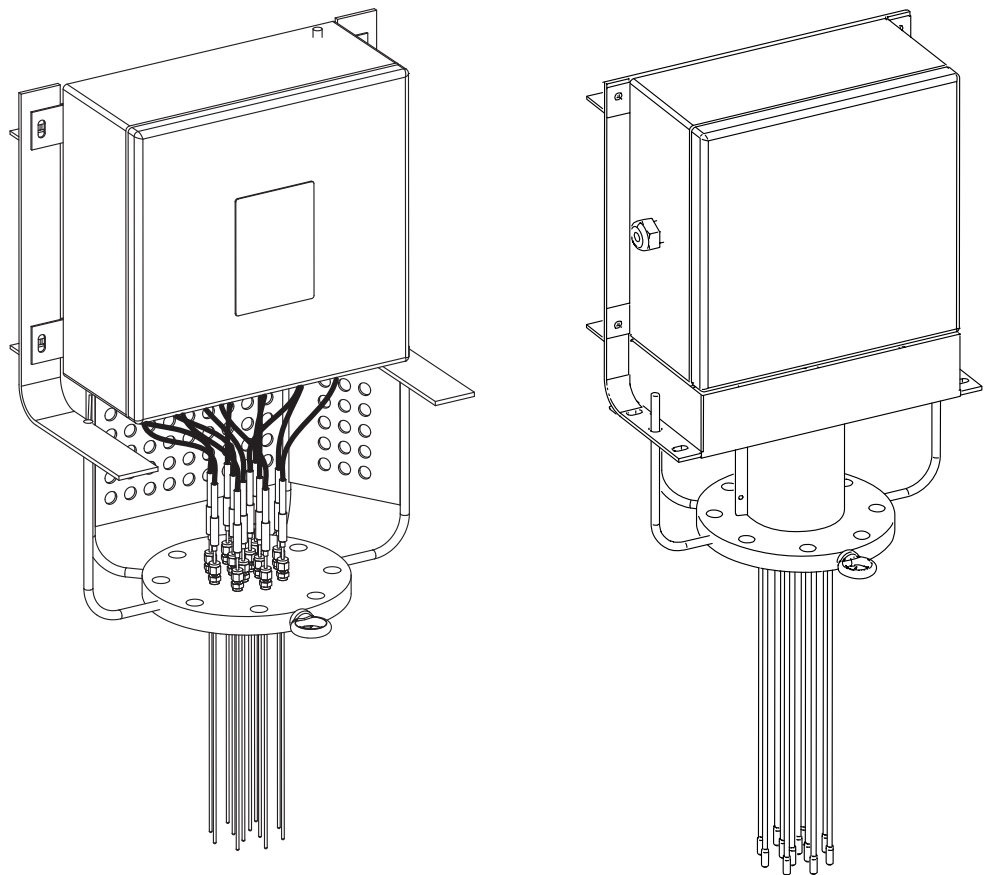

Table of contents

1	About this document	4	10	Accessories	29
1.1	Document function	4	10.1	Device-specific accessories	29
1.2	Symbols	4	10.2	Communication-specific accessories	30
2	Basic safety instructions	6	10.3	Service-specific accessories	31
2.1	Requirements for the personnel	6	11	Technical data	32
2.2	Designated use	6	11.1	Input	32
2.3	Workplace safety	7	11.2	Output	32
2.4	Operational safety	7	11.3	Environment	33
2.5	Product safety	7	11.4	Mechanical construction	34
3	Product description	8	11.5	Certificates and approvals	40
3.1	Product design	8	11.6	Documentation	41
4	Incoming acceptance and product identification	11			
4.1	Incoming acceptance	11			
4.2	Product identification	11			
4.3	Storage and transport	12			
5	Mounting	13			
5.1	Mounting requirements	13			
5.2	Mounting the assembly	14			
5.3	Post-mounting check	16			
6	Wiring	18			
6.1	Quick wiring guide	18			
6.2	Connecting the sensor cables	20			
6.3	Connecting the power supply and signal cables	21			
6.4	Shielding and grounding	22			
6.5	Degree of protection	22			
6.6	Post-connection check	22			
7	Commissioning	24			
7.1	Preliminaries	24			
7.2	Function check	24			
7.3	Switching on the device	26			
8	Diagnostics and troubleshooting ...	26			
8.1	General troubleshooting	26			
9	Repair	27			
9.1	General notes	27			
9.2	Spare parts	27			
9.3	Endress+Hauser services	27			
9.4	Return	27			
9.5	Disposal	28			





1 About this document

1.1 Document function







These Operating Instructions contain all the information that is required in various phases of the life cycle of the device: from product identification, incoming acceptance and storage, to mounting, connection, operation and commissioning through to troubleshooting, maintenance and disposal.

1.2 Symbols



1.2.1 Safety symbols









Symbol	Meaning
	DANGER! This symbol alerts you to a dangerous situation. Failure to avoid this situation will result in serious or fatal injury.
	WARNING! This symbol alerts you to a dangerous situation. Failure to avoid this situation can result in serious or fatal injury.
	CAUTION! This symbol alerts you to a dangerous situation. Failure to avoid this situation can result in minor or medium injury.
	NOTE! This symbol contains information on procedures and other facts which do not result in personal injury.

1.2.2 Electrical symbols

Symbol	Meaning
	Direct current
	Alternating current
	Direct current and alternating current
	Ground connection A grounded terminal which, as far as the operator is concerned, is grounded via a grounding system.
	Protective ground connection A terminal which must be connected to ground prior to establishing any other connections.
	Equipotential connection A connection that has to be connected to the plant grounding system: This may be a potential equalization line or a star grounding system depending on national or company codes of practice.

1.2.3 Symbols for certain types of information

Symbol	Meaning
	Permitted Procedures, processes or actions that are permitted.
	Preferred Procedures, processes or actions that are preferred.

Symbol	Meaning
	Forbidden Procedures, processes or actions that are forbidden.
	Tip Indicates additional information.
	Reference to documentation
	Reference to page
	Reference to graphic
	Series of steps
	Result of a step
	Help in the event of a problem
	Visual inspection

1.2.4 Documentation

Document	Purpose and content of the document
iTHERM TMS01 MultiSens Flex (TI01256T/09/)	Planning aid for your device The document contains all the technical data on the device and provides an overview of the accessories and other products that can be ordered for the device.

 The document types listed are available:
In the Download Area of the Endress+Hauser Internet site: www.endress.com → Downloads

1.2.5 Registered trademarks

- FOUNDATION™ Fieldbus
Registered trademark of the Fieldbus Foundation, Austin, Texas, USA
- HART®
Registered trademark of the HART® FieldComm Group
- PROFIBUS®
Registered trademark of the PROFIBUS Nutzerorganisation e.V. (Profibus User Organization), Karlsruhe - Germany

2 Basic safety instructions

Instructions and procedures in the operating instructions may require special precautions to ensure the safety of the personnel performing the operations. Information that potentially raises safety issues is indicated by safety pictograms and symbols. Please refer to the safety messages before performing an operation preceded by pictograms and symbols. Although the information provided herein is believed to be accurate, be advised that the information contained herein is NOT a guarantee of satisfactory results. Specifically, this information is neither a warranty nor guarantee, expressed or implied, regarding performance. Please note that the manufacturer reserves the right to change and / or improve the product design and specifications without notice.

2.1 Requirements for the personnel

The personnel for installation, commissioning, diagnostics and maintenance must fulfill the following requirements:

- ▶ Trained, qualified specialists must have a relevant qualification for this specific function and task
- ▶ Are authorized by the plant owner/operator
- ▶ Are familiar with federal/national regulations
- ▶ Before beginning work, the specialist staff must have read and understood the instructions in the Operating Instructions and supplementary documentation as well as in the certificates (depending on the application)
- ▶ Following instructions and basic conditions

The operating personnel must fulfill the following requirements:

- ▶ Being instructed and authorized according to the requirements of the task by the facility's owner-operator
- ▶ Following the instructions in these Operating Instructions

2.2 Designated use

The product is intended to measure the temperature profile inside a reactor, vessel or pipe through RTD or thermocouple technologies.

The manufacturer is not liable for damage caused by improper or non-designated use.

The product has been designed according to the following conditions:

Condition	Description
Internal pressure	The design of joints, threaded connections and sealing elements has been executed as a function of the maximum allowable pressure inside the reactor.
Operating temperature	The materials used were chosen according to the operating and design minimum and maximum temperatures. Thermal displacement has been taken into account to avoid intrinsic stresses and to ensure proper integration between the instrument and the plant. Specific care has to be taken when the instrument's sensing elements are fixed to the plant internals.
Process fluids	Dimensions and choice of materials minimize: <ul style="list-style-type: none"> ▪ distributed and localized corrosion, ▪ erosion and abrasion, ▪ corrosion phenomena due to uncontrolled and unpredictable chemical reactions. Specific process fluids analysis is necessary to properly ensure the maximum operating life of the device, through proper material selection.
Fatigue	Cyclic loads during operations are not foreseen.

Condition	Description
Vibrations	The sensing elements can be subjected to vibrations, due to high immersion lengths from the constraint located in the process connections. This vibrations can be minimized by properly selecting the route of the sensing element into the plant, by fixing it on internals by means of accessories like clips and end tips. The extension neck has been designed for withstanding vibratory loads to preserve the junction box from cyclic loading, and to avoid the unscrewing of the threaded components.
Mechanical stress	The maximum stress on the measuring device multiplied by a safety factor is guaranteed to stay below the yielding stress of the material, for every working condition of the plant.
External environment	The junction box (with and without head transmitters), wires, cable glands and other fittings have been selected to work within the allowed ranges in terms of external temperature.

2.3 Workplace safety

The external installation area must be free of interferences to avoid any injury during installation, and to avoid any damage to the measuring device.

2.4 Operational safety

- ▶ Operate the device in proper technical condition and fail-safe condition only.
- ▶ The operator is responsible for interference-free operation of the device.

Hazardous area

To eliminate a danger for persons or for the facility when the device is used in the hazardous area (e.g. explosion protection or safety equipment):

- ▶ Based on the technical data on the nameplate, check whether the ordered device is permitted for the intended use in the hazardous area. The nameplate can be found on the side of the junction box.
- ▶ Observe the specifications in the separate supplementary documentation that is an integral part of these Instructions.



Electromagnetic compatibility

The measuring system complies with the general safety requirements in accordance with EN 61010-1, the EMC requirements of IEC/EN 61326 and NAMUR Recommendation NE 21 and NE 89.

NOTICE

- ▶ The unit must only be powered by a power supply that operates using an energy-limited electric circuit that is compliant with IEC 61010-1, "SELV or Class 2 circuit".

2.5 Product safety

The unit is constructed using the most up-to-date production equipment and complies with the safety requirements of the local guidelines. The temperature measuring system is fully factory tested according to the specifications indicated on the order and/or any additional test which is considered as safety-relevant. However, if it is installed incorrectly or is misused, certain application dangers can occur. Installation, wiring and maintenance of the unit must only be done by trained, skilled personnel who are authorized to do so by the plant operator. This skilled staff must have read and understood these instructions and must follow them. The plant operator must make sure that the measurement system has been installed by tightening the threaded components (e.g bolts and nuts) with the predefined torques and tools →  13, and correctly wired according to the wiring diagrams. →  18

3 Product description

3.1 Product design

The multipoint thermometer belongs to a range of modular product configuration for multipoint temperature detection with a design where subassemblies and components can be managed individually for easy maintenance and spare part ordering.

It consists of the following main sub-assemblies:

- **Insert:** Done by a metal sheathed sensing measuring element (thermocouple or resistance), extension cables and transition bushing. Each insert can be handled as an individual spare part that is replaceable by untightening its compression fitting installed onto the process connection. They can be ordered via specific standard product order codes (e.g. TSC310, TST310) or special codes. For the specific order code please contact the Endress+Hauser service department.
- **Process connection:** Represented by an ASME or EN flange, it might be provided with eyebolts for lifting the device.
- **Head:** It is composed of a junction box provided with its components such as cable glands, draining valves, earth screws, terminals, head transmitters, etc.
- **Neck:** It is designed to support the junction box by components such as supporting rods and plates or tube extension.
- **Additional accessories:** Components that can be ordered independently from the selected product configuration, such as clips, pads, tips, spacers and plates for tag sensors.
- **Thermowells:** They are directly welded on the process connection, designed to guarantee higher degree of mechanical protection and corrosion resistance for each sensor.

In general, the system measures the temperature profile inside the process environment by means of many sensors, jointed to a suitable process connection which ensures the right tightness levels. Externally, the extension cables are wired into the junction box, which can be directly mounted or remote as option.

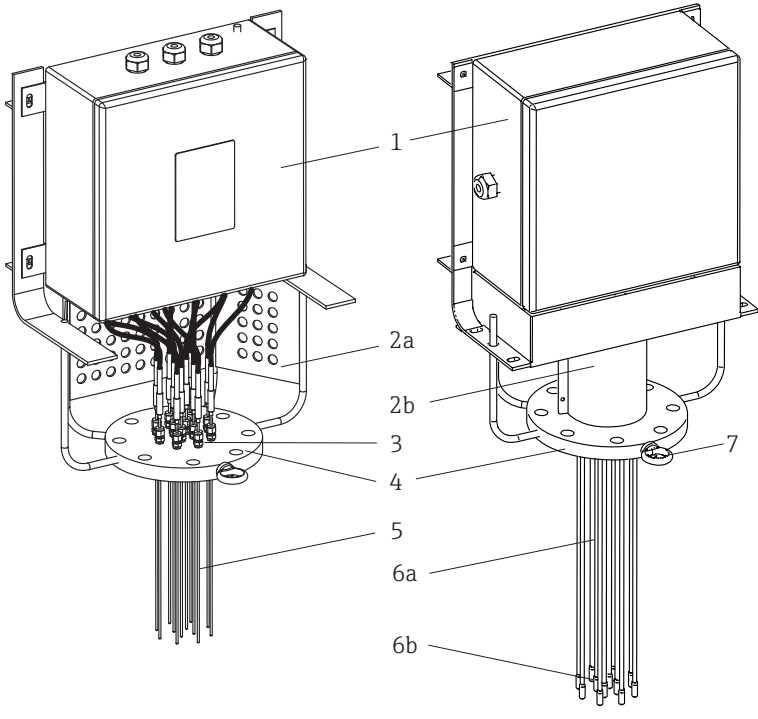
Design	Description, available options and materials	
	<p>1: Head</p> <p>Hinged cover junction box for electrical connections. It includes components such as electrical terminals, transmitters and cable glands.</p> <ul style="list-style-type: none"> ▪ 316/316L ▪ Other materials on request 	
	<p>2a: Frame neck and 2b: Tube neck</p> <p>Modular frame support that is adjustable for all available junction boxes.</p> <p>316/316L</p> <p>Modular tube support that is adjustable for all available junction boxes and ensures extension cable inspection.</p> <p>316/316L</p>	
	<p>3: Compression fitting</p> <p>High performance compression fitting for a proper tightness between process and external environment, for a wide range of process fluids concentration and severe combination between temperature and pressure.</p> <ul style="list-style-type: none"> ▪ 316L ▪ 316H 	

Design	Description, available options and materials	
	4: Process connection	Represented by a flange according to international standards, or engineered to satisfy specific process requirements. →  39 <ul style="list-style-type: none"> ■ 304 + 304L ■ 316 + 316L ■ 316Ti ■ 321 ■ 347 ■ Other materials on request
	5: Insert	<ul style="list-style-type: none"> ■ Thermocouple (type J, K) grounded and ungrounded execution or RTD (Pt100 wire wound). ■ Insert sheath material: Alloy600, 316, 316L, Pyrosil ■ Available in several diameters, please refer to the ordering information table.
	6a: Protecting thermowells 6b: Guiding open tubes	The thermometer can be equipped: <ul style="list-style-type: none"> ■ either with protecting thermowells for increased mechanical strength and corrosion resistance ■ or open guiding tubes for installation in an existing thermowell. <ul style="list-style-type: none"> ■ 316/316L ■ 321 ■ 347 ■ Alloy 600 ■ Other materials on request
	7: Eyebolt	Lifting device for easy handling during installation phase. 316

The modular multipoint thermometer is characterized by the following possible main configurations:

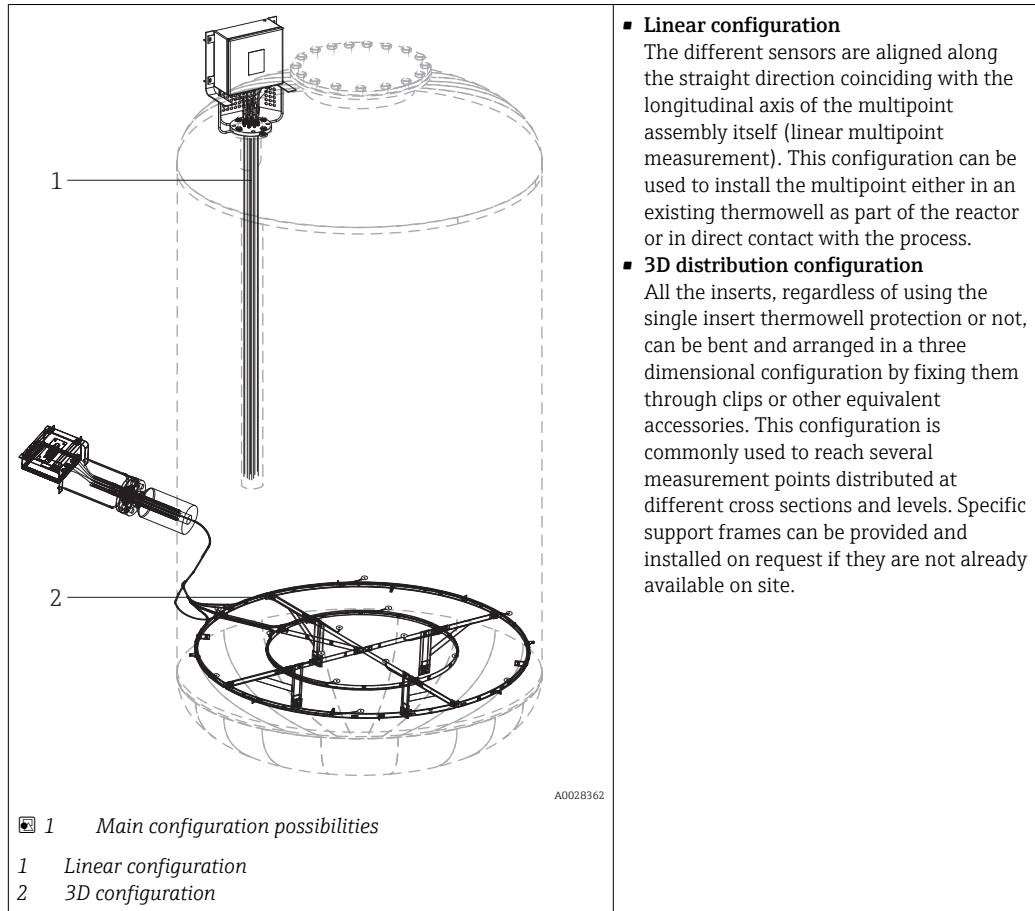

- **Linear configuration**

The different sensors are aligned along the straight direction coinciding with the longitudinal axis of the multipoint assembly itself (linear multipoint measurement). This configuration can be used to install the multipoint either in an existing thermowell as part of the reactor or in direct contact with the process.

- **3D distribution configuration**

All the inserts, regardless of using the single insert thermowell protection or not, can be bent and arranged in a three dimensional configuration by fixing them through clips or other equivalent accessories. This configuration is commonly used to reach several measurement points distributed at different cross sections and levels. Specific support frames can be provided and installed on request if they are not already available on site.

4 Incoming acceptance and product identification

4.1 Incoming acceptance

Before proceeding with the installation the following incoming acceptance procedures are suggested:

- Once the device is received it is always suggested to verify the integrity of the packaging and possible damages. Non-compliances should be immediately reported to the manufacturer. Damaged material shall not be installed: in these conditions, in fact, the manufacturer cannot guarantee the original safety requirements and cannot be considered responsible for any consequential effect.
- Compare the scope of delivery with the order content.
- Carefully remove all packaging/protection related to the freight.

4.2 Product identification

The following options are available for identification of the device:

- Nameplate specifications
- Enter the serial number from the nameplate in the *W@M Device Viewer* <https://www.endress.com/deviceviewer>. All data relating to the device and an overview of the Technical Documentation supplied with the device are displayed.

The following nameplate layout serves to identify the specific product information from the serial number, design conditions, sizes, configuration to approvals:

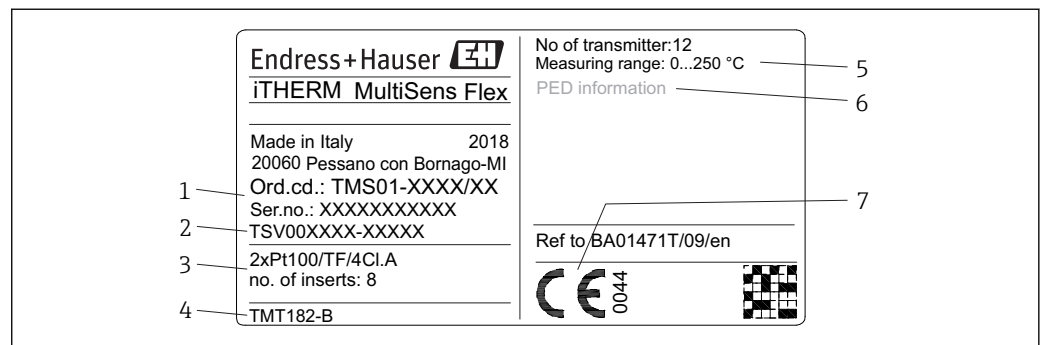

2 Nameplate of the multipoint thermometer (example as landscape format)

Field number	Description	Examples
1	Order code and serial number	-
2	TSV drawing number	TSV301237-XXXXX
3	Sensor and product configuration	e.g. number of measuring points
4	Assembled transmitter	-
5	Sensor measuring temperature range	-
6	PED information (if applicable)	e.g. volume, pressure, temperature

Field number	Description	Examples
7	CE marking	-
-	Approval number, hazardous area classification and Ex logo (if applicable) Safety instructions number (if applicable) Ambient temperature (if hazardous area classification is applicable)	- - e.g. -50 to 60 °C (-58 to 140 °F) for hazardous area application

 Compare and check the data on the nameplate of the device against the requirements of the measurement point.

4.3 Storage and transport

Carefully remove each package and protection relative to the transportation packaging.

NOTICE

Transportation of the device to the installation area

- ▶ Handle the device by always using the provided eyebolt as the main lifting part.
- ▶ Handle with care. During mounting phases avoid each load to welded or threaded parts, under the action of the weight of the device.
- ▶ When the device has to pass from the horizontal to the vertical position or vice versa, particular attention must be taken.
- ▶ It is strictly requested to avoid bumping against obstacles nearby the place where the device is to be installed.
- ▶ Avoid any friction between the device and the other surrounding bodies.
- ▶ Avoid twisting of the sensing element twisting.

 Pack the device in such a way as to protect it reliably against impact for storage (and transportation). The original packaging provides optimum protection.

For permitted storage temperature →  33

5 Mounting

5.1 Mounting requirements

⚠ WARNING

Failure to follow these installation guidelines could result in death or serious injury

- ▶ Make sure only qualified personnel perform the installation.

⚠ WARNING

Explosions could result in death or serious injury

- ▶ Do not remove the junction box cover in explosive atmospheres when the circuit is live.
- ▶ Before connecting any additional electric and electronic device in an explosive atmosphere, make sure the instruments in the loop are installed in accordance with intrinsically safe or non incandive field wiring practices.
- ▶ Verify that the operating atmosphere of the transmitters is consistent with the appropriate hazardous locations certifications.
- ▶ All covers and threaded components must be fully engaged to meet explosion-proof requirements.

⚠ WARNING

Process leaks could result in death or serious injury

- ▶ Do not release screwed parts while in operation. Install and tighten the fittings before applying pressure.

NOTICE

Additional loads and vibrations from other plant components can affect the operation of the sensor elements.

- ▶ Is it not allowed to apply additional loads or external moments to the system coming from the connection with another system not foreseen from installation plan.
- ▶ The system is not suitable for being installed in locations where vibrations are present. The deriving loads can undermine the sealing of the junctions and damage the operation of the sensing elements.
- ▶ It will be care of the final user to verify the installation of suitable devices in order to avoid the overcoming of the admitted limits.
- ▶ For the environment conditions please refer to the technical data →  33
- ▶ When installing in an existing thermowell, an internal inspection of the thermowell is recommended to check if any internal load is present before starting with the insertion activities of the whole device. While installing the measurement system, avoid any friction during installation, specifically avoid sparks generation. Ensure the thermal contact between the inserts and the bottom/wall of the existing thermowell. When accessories like spacers are provided, make sure that no distortions are occurred and the original geometry and position is maintained.
- ▶ When the installation is performed by direct contact with the process, ensure that any applied external loads (i.e. due to the tip fixing of the probe to any reactor internals) don't generate deformations and strains on the probe and on welds.

5.2 Mounting the assembly

The following instructions have to be followed for the proper installation of the device:

1.

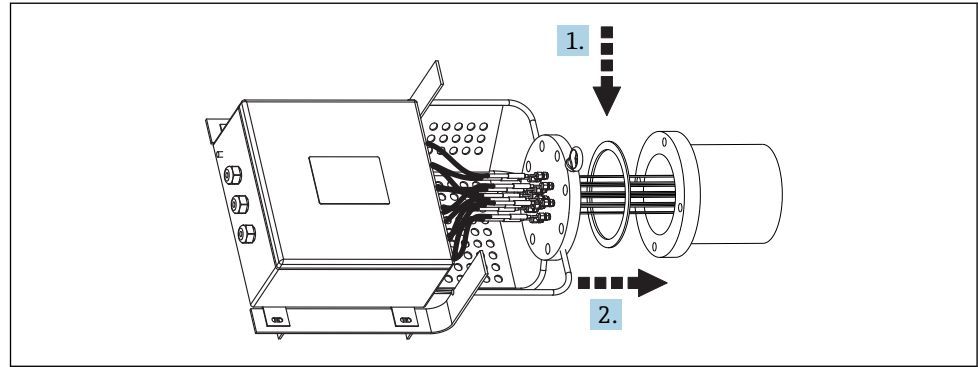

A0028369

Place the gasket between the flanged nozzle and the flange of the device (after checking the cleanliness of gasket seats on the flanges).

2.

Bring the device to the nozzle, inserting the thermoelements or the thermoelements bundle through the nozzle, avoiding interlacing and deformation of the same.

3.

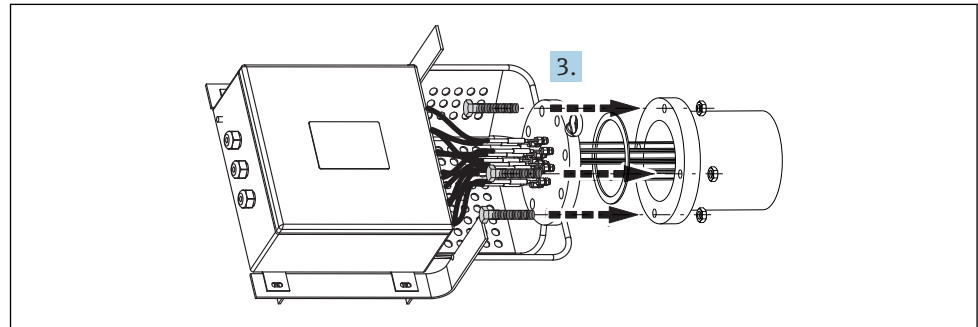

A0028370

Start the bolts insertion through the flanges' holes and tighten them with the nuts by using a suitable wrench tool - but do not tighten them completely.

4.

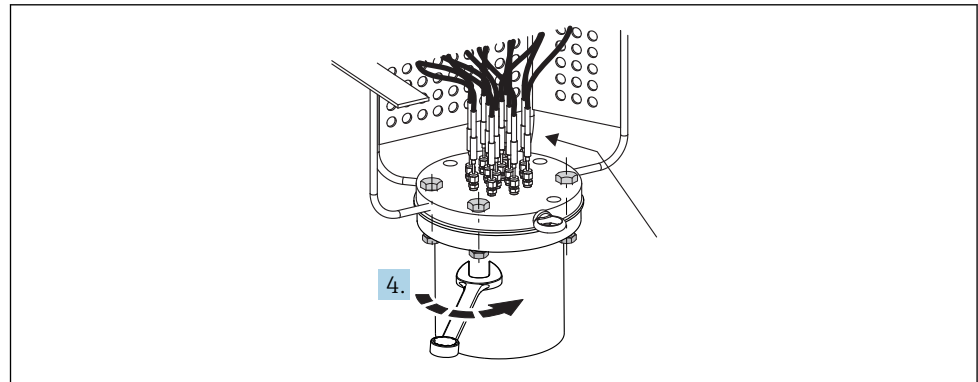

A0028374

Complete the bolts insertion through the flanges' holes and tight them with the crossed method by means of an appropriate equipment (i.e. controlled tensioning according to the applicable standards).

5.

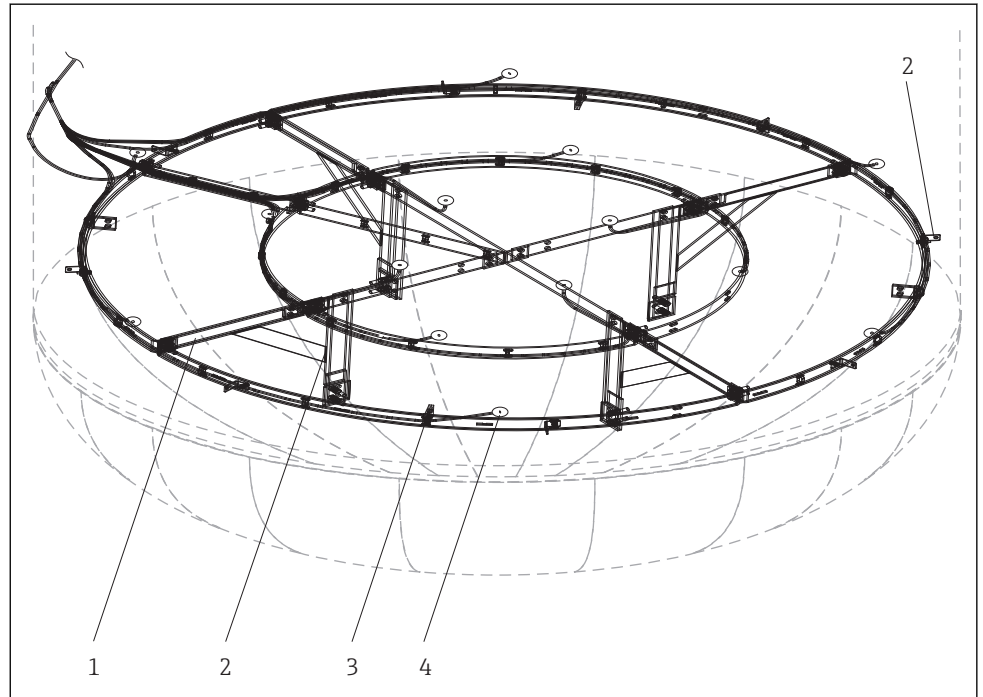

A0029266

- 1 Support frame
- 2 Fixing bar
- 3 Fixing clip
- 4 Inserts or protecting thermowells tip

A) For 3D installation fix all the inserts or thermowells to the support structures (frame, bars, clips and all the accessories foreseen) according to drawings starting from the tip fixing and bending the rest along its length. When the complete path is defined, **permanently** fix the inserts or thermowells from the nozzle to the tip having the chance to leave the extra-length close to the measuring point by means of U or Ω curves (when necessary). Remark: Bend each probe with a minimum radius of 5 times its external diameter and fix it to the pre-mounted structures inside the reactor by means of clips, tie wraps or welding it.

6.

B) When installing in an existing thermowell, it is recommended to perform an internal inspection of the thermowell. Check if there is any obstacle, with the aim of making an easy insertion. While installing the measurement system, avoid any friction during installation, specifically avoid sparks generation. Ensure that the thermal contact between the tip end of the inserts or thermowells and the existing thermowell wall is guaranteed. When accessories such as spacers and/or centered rods are provided, make sure that no distortions can occur and that the original geometry is maintained.

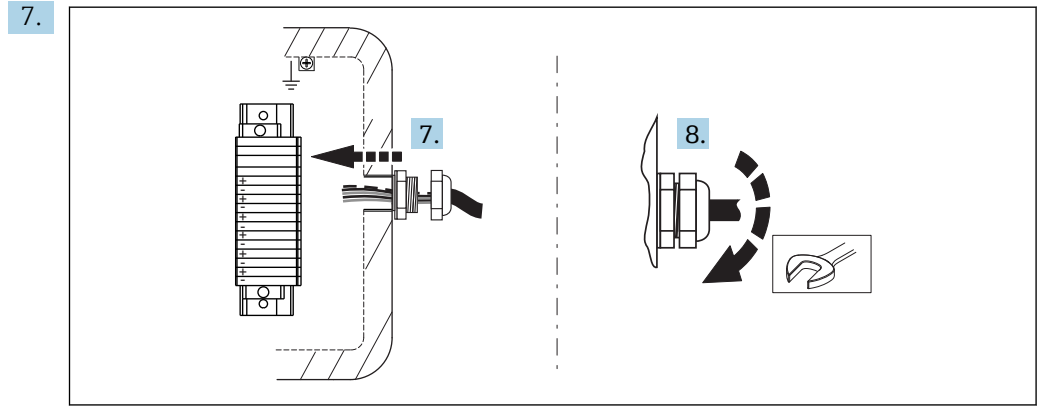

- 7. In case of direct wiring completely introduce the extension or compensating cables through the respective cable glands in the junction box.
- 8. Tighten the cable glands on the junction box.
- 9. After having opened the cover of the junction box, connect the compensating cables to the terminals of the junction box following the wiring instruction provided, ensuring the right matching between the cable tag numbers and the terminals tag numbers.
- 10. Close the cover ensuring the right gasket position to avoid any impact on the IP degree of protection.
- 11. In case of using the tube neck, check if all its components are still coupled properly one each other.

The mounting of the assembly is completed.

NOTICE

After the mounting, perform few simple checks on the thermometric system installed.

- ▶ Check the tightness of the threaded connections. If any part is loosened, tight it applying the proper torque.
- ▶ Check for correct wiring, test the electrical continuity of the thermocouples (warming up the thermocouple hot junction, when feasible) and then verify the absence of short circuits.

5.3 Post-mounting check

Before commissioning the measuring system make sure that all final checks have been carried out:

Device conditions and specifications	
Is the device undamaged (visual inspection)?	<input type="checkbox"/>
Do the ambient conditions match the device specification? For example: ▪ Ambient temperature ▪ Proper conditions	<input type="checkbox"/>
Are the threaded components undeformed?	<input type="checkbox"/>
Are the gaskets not permanently deformed?	<input type="checkbox"/>
Installation	
Is the equipment aligned with the nozzle axis?	<input type="checkbox"/>
Are the gasket seats of flanges clean?	<input type="checkbox"/>
Is the coupling between the flange and its counter flange reached?	<input type="checkbox"/>

Are the thermoelements not interlaced and undeformed?	<input type="checkbox"/>
Are the bolts completely inserted in the flange? Make sure the flange is completely attached to the nozzle.	<input type="checkbox"/>
Are the thermoelements fixed to the support structures? →  15	<input type="checkbox"/>
Are the cable glands tightened on the extension cables?	<input type="checkbox"/>
Are the extension cables connected to the junction box terminals?	<input type="checkbox"/>

6 Wiring





CAUTION

Failure to observe this may result in destruction of parts of the electronics.

- ▶ Switch off power supply before installing or connecting the device.
- ▶ When installing Ex-approved devices in a hazardous area please take special note of the instructions and connection schematics in the respective Ex documentation added to these Operating Instructions. The local Endress+Hauser representative is available for assistance if required.

 When wiring to a transmitter also observe the wiring instructions in the enclosed Brief Operating manuals of the relevant transmitter.

For wiring the device proceed as follows:

1. Open the housing cover on the junction box.
2. Open the cable glands on the sides of the junction box. →  16
3. Feed the cables through the opening in the cable glands.
4. Connect the cables as shown on →  18
5. On completion of the wiring, screw the screw terminals tight. Tighten the cable glands again. In doing so, also pay particular attention to →  22. Close the housing cover again.
6. In order to avoid connection errors always take note of the hints given in the post connection check! →  22

6.1 Quick wiring guide

Terminal assignment

NOTICE

Destruction or malfunction of parts of the electronics through ESD - electrostatic discharge.

- ▶ Take measures to protect the terminals from electrostatic discharge.

 To avoid incorrect measuring values an extension or compensation cable for direct wiring of thermocouple and RTD sensors for the signal transmission has to be used. The polarity indication on the respective terminal block and the wiring scheme has to be observed.

The planning and the installation of the bus connection cables of the plant is not to be concerned of the manufacturer of the device. Therefore the manufacturer cannot be considered to be responsible for possible damages due to the choice of materials that are not suitable for that application or to a faulty installation.

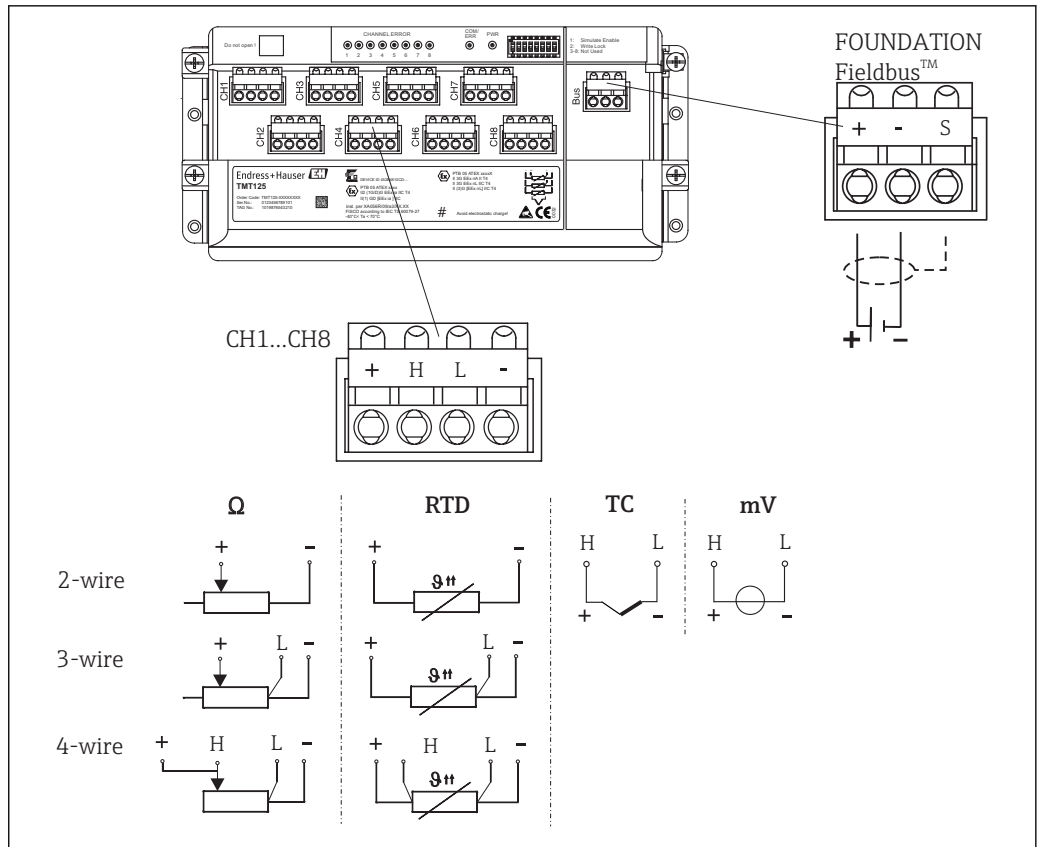

A0006330-EN

3 Wiring diagram of multi channel transmitter

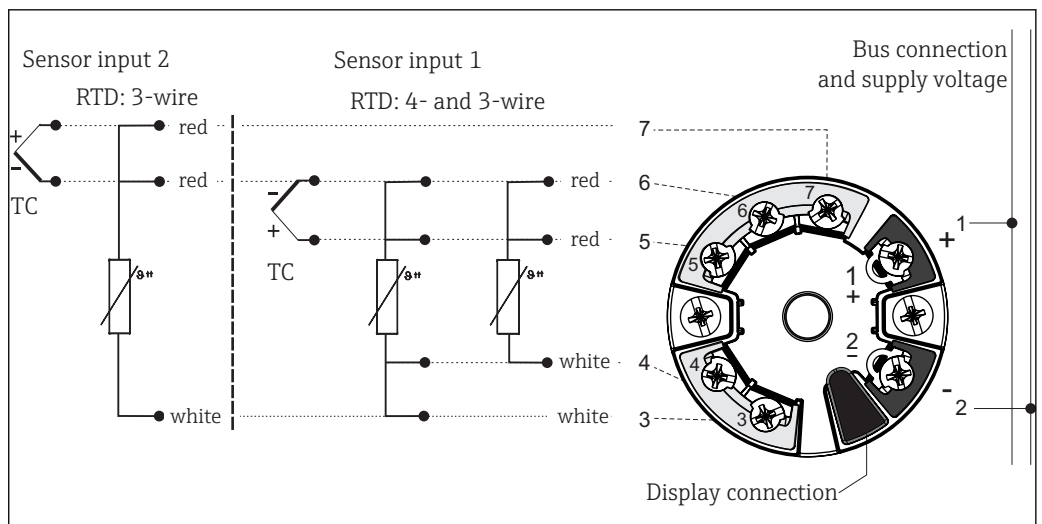

A0016711-EN

4 Wiring diagram of the dual sensor input head transmitters (TMT8x)

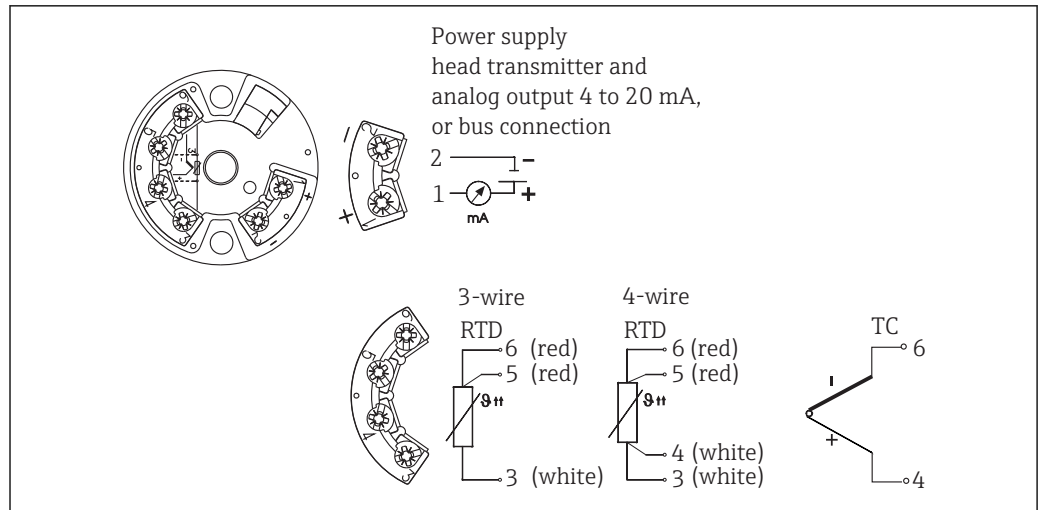

A0016712-EN

5 Wiring diagram of the single sensor input head transmitters (TMT18x)

Thermocouple cable colors

According to IEC 60584	According to ASTM E230
<ul style="list-style-type: none"> Type J: Black (+), white (-) Type K: Green (+), white (-) Type N: Pink (+), white (-) Type T: Brown (+), white (-) 	<ul style="list-style-type: none"> Type J: White (+), red (-) Type K: Yellow (+), red (-) Type N: Orange (+), red (-) Type T: Blue (+), red (-)

6.2 Connecting the sensor cables

i Each sensor is marked with an individual TAG number. As default configuration, all wires are always connected to the installed transmitters or terminals and generally checked in house before final shipment.

The wiring is done in consecutive order, which means that the input channel(s) of transmitter no. 1 are connected to the insert wires starting from insert no. 1. Transmitter no. 2 is not used until all channels of transmitter no. 1 are fully connected. The wires of each insert are marked with consecutive numbers starting from 1. If double sensors are used the internal marking has a suffix to distinguish the two sensors, e.g. 1A and 1B for double sensors in the same insert or measuring point no. 1.

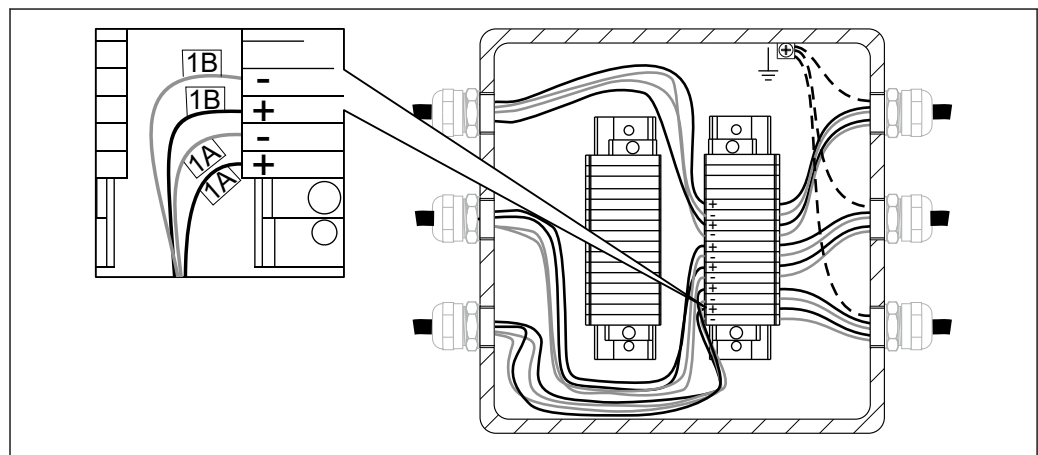

A0033288

6 Direct wiring on the mounted terminal block. Example for the internal sensor wires marking with 2 x TC sensors in insert no. 1.

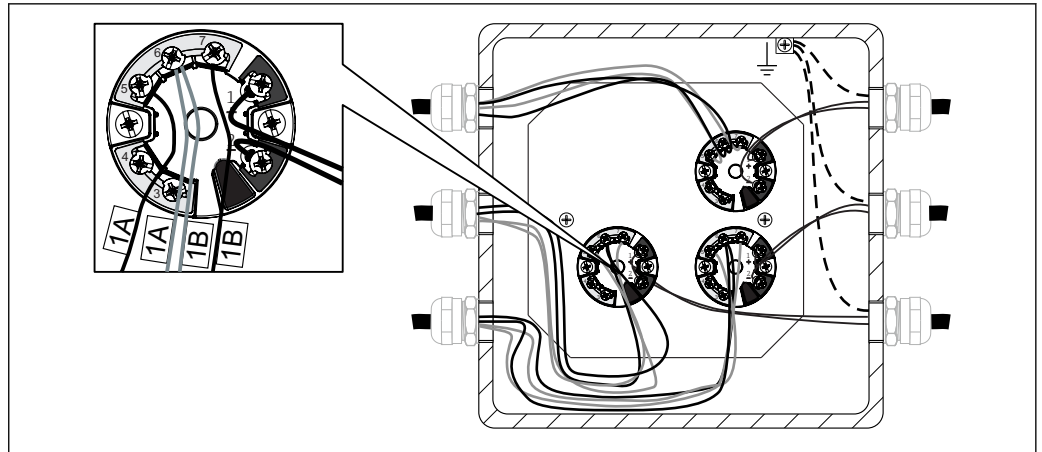

A0033289

7 Mounted and wired head transmitter. Example for the internal sensor wires marking with 2 x TC

Sensor type	Transmitter type	Wiring rule
1 x RTD or TC	<ul style="list-style-type: none"> ▪ Single input (one channel) ▪ Double input (two channel) ▪ Multi-channel input (8 channel) 	<ul style="list-style-type: none"> ▪ 1 Head transmitter per insert ▪ 1 Head transmitter for 2 inserts ▪ 1 Multi-channel transmitter for 8 inserts
2 x RTD or TC	<ul style="list-style-type: none"> ▪ Single input (one channel) ▪ Double input (two channel) ▪ Multi-channel input (8 channel) 	<ul style="list-style-type: none"> ▪ Not available, wiring excluded ▪ 1 Head transmitter per insert ▪ 1 Multi-channel transmitter for 4 inserts

6.3 Connecting the power supply and signal cables

Cable specification

- A shielded cable is recommended for fieldbus communication. Take the plant grounding concept into consideration.
- The terminals for connecting the signal cable (1+ and 2-) are protected against reverse polarity.
- Conductor cross-section:
 - Max 2.5 mm² (14 AWG) for screw terminals
 - Max 1.5 mm² (16 AWG) for spring terminals

Always observe the general procedure on → 18.

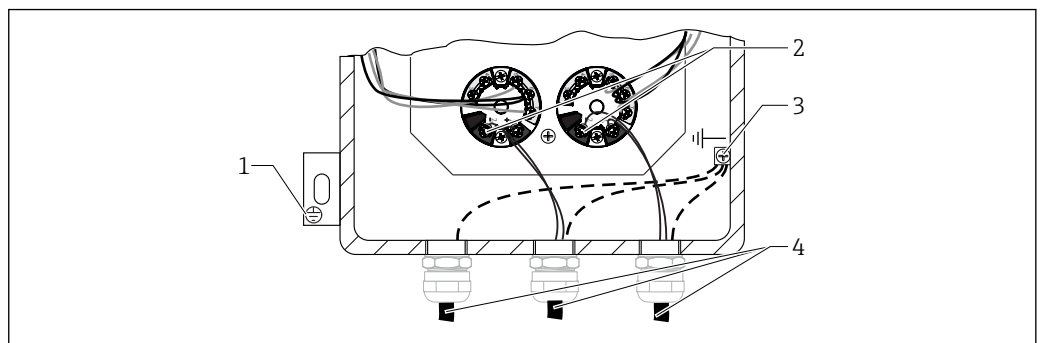

A0033290

8 Connecting the signal cable and power supply to the installed transmitter

- 1 External ground terminal
- 2 Terminals for signal cable and power supply
- 3 Internal ground terminal
- 4 Shielded signal cable, recommended for fieldbus connection

6.4 Shielding and grounding

i For any specific electrical shielding and grounding regarding the transmitter wiring please refer to the appropriate operating manual of the installed transmitter.



Where applicable, national installation regulations and guidelines must be observed during the installation! Where there are large differences in potential between the individual grounding points, only one point of the shielding is connected directly with the reference ground. In systems without potential equalization, therefore, cable shielding of fieldbus systems should only be grounded on one side, for example at the supply unit or at safety barriers.

NOTICE

If the shielding of the cable is grounded at more than one point in systems without potential matching, power supply frequency equalizing currents can occur that damage the signal cable or have a serious effect on signal transmission.

- ▶ In such cases the shielding of the signal cable is to be grounded on only one side, i.e. it must not be connected to the ground terminal of the housing (terminal head, field housing). The shield that is not connected should be insulated!

6.5 Degree of protection

In order to fulfil the degree of protection after installation or service, the following points must be taken into consideration: →  9,  22

- The housing seals must be clean and undamaged before they are replaced in the sealing rebate. If they are found to be too dry, they should be cleaned or even replaced.
- All housing screws and covers must be tightened.
- The cables used for connection must be of the correct specified outside diameter (e.g. M20 x 1.5, cable diameter from 0.315 to 0.47 in; 8 to 12 mm).
- Tighten cable gland or NPT fitting.
- Loop the cable or conduit before placing into the entry ("Water sack"). This means that any moisture that may form cannot enter the gland. Install the device so that the cable or conduit entries are not facing upwards.
- Entries not used are to be blanked off using the blanking plates provided.
- The protective grommet must not be removed from the NPT fitting.

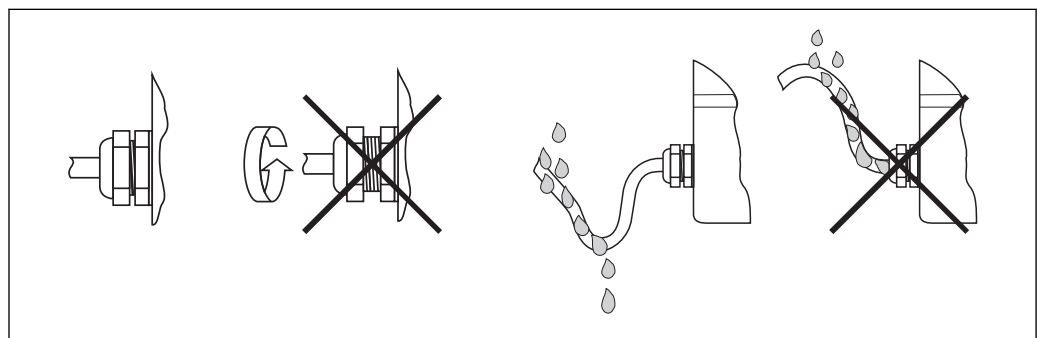

A0011260

 9 Connection hints to maintain IP protection

6.6 Post-connection check

Is the device undamaged (internal equipment inspection)?	<input type="checkbox"/>
Electrical connection	
Does the supply voltage match the specifications on the nameplate? This depends on the applied transmitter.	<input type="checkbox"/>
Do the cables have adequate strain relief?	<input type="checkbox"/>

Are the power supply and signal cables correctly connected? →  18	<input type="checkbox"/>
Are all the screw terminals well tightened and have the connections of the spring terminals been checked?	<input type="checkbox"/>
Are all the cable glands installed, tightened and sealed?	<input type="checkbox"/>
Are all the housing covers installed and tightened?	<input type="checkbox"/>
Does the marking of the terminals and cables match?	<input type="checkbox"/>
Is the electrical continuity of the thermocouple verified?	<input type="checkbox"/>

7 Commissioning

7.1 Preliminaries

Set-up guidelines of Standard, Extended and Advanced Commissioning for Endress+Hauser instruments in order to guarantee the function of the instrument according to:

- Endress+Hauser operating manual
- Customer set up specification, and/or
- Application conditions, when applicable under process conditions

Both the operator and the person responsible for the process should be informed that a commissioning job will be carried out, observing the following actions:

- If applicable, before disconnecting any sensor that is attached to the process, determine what chemical or fluid is being measured (observe safety data sheet).
- Be aware of the temperature and pressure conditions.
- Never open a process fitting or loosen flange bolts before you have confirmed it is safe to do so.
- Be sure not to disturb the process when disconnecting inputs/outputs or when simulating signals.
- Ensure our tools, equipment and the customer process are protected from cross contamination. Consider and plan necessary cleaning steps.
- When commissioning requires chemicals (e.g. as reagents for standard operation or for cleaning purposes), always follow and observe the safety regulations.

7.1.1 Reference documents



- Endress+Hauser Standard Operating Procedure for Health and Safety (see documentation code: BP01039H)
- Operating Manual of relevant tools and equipment to perform the commissioning job.
- Relevant Endress+Hauser Service Documentation (operating manual, work instructions, service info, service manual, etc.).
- Calibration certificates of the quality relevant equipment if available.
- If applicable, safety data sheet.
- Customer specific documents (safety instructions, setup points, etc.).

7.1.2 Tools and equipment

Multimeter and instrument related configuration tools as necessary from the above mentioned action list.

7.2 Function check

Before commissioning the device make sure that all final checks have been carried out

- "Post-mounting check" checklist →  16
- "Post-connection check" checklist →  22

The commissioning should be performed according to our commissioning segmentation (Standard, Extended and Advanced).

7.2.1 Standard commissioning

Visual inspection of device

1. Check the instrument(s) for damage which may have been caused during transport/shipping or mounting/wiring
2. Check that the installation is done according to the operating manual

3. Check that the wiring is done according to the operating manual and the local regulations (e.g. grounding)
4. Check the dust/water tightness of the instrument(s)
5. Check safety precautions (e.g.. radiometric measurements)
6. Power up the instrument(s)
7. Check the alarm list if applicable

Environmental conditions

1. Check that the environmental conditions are appropriate for the instrument(s): Ambient temperature, humidity (ingress protection IPxx), vibrations, hazardous areas (Ex, Dust-Ex), RFI/EMC, sun protection, etc.
2. Check access to the instrument(s) for utilization and maintenance

Configuration parameters

- ▶ Configure the instrument(s) according to the Operating Manual with the parameters specified by the customer or mentioned on the design specification

Output signal value check

- ▶ Check and confirm that the local display and the output signals of the instrument(s) conform with the customer's display

7.2.2 Extended commissioning

In addition to the steps of Standard Commissioning, the following should be additionally completed:

Instrument Conformity

1. Check the received instrument(s) with the purchase order or design specification including accessories, documentation and certificates
2. Check Software Version (e.g. application software such as "Batching") when provided
3. Check that the documentation has the correct issue and version

Functional test

1. Test of the instrument outputs, including switching points, auxiliary inputs/outputs with the internal or an external simulator (e.g. FieldCheck)
2. Compare the measuring data/results with a reference from the customer. (e.g. laboratory result in case of an analyzer, weight scale in the case of a batching application, etc.)
3. Adjust the instrument(s) if necessary and as described in the operating manual

7.2.3 Advanced commissioning

The Advanced Commissioning provides a loop test in addition to the steps covered in the Standard and Extended Commissioning.

Loop test

1. Simulate a minimum of 3 output signals from the instrument(s) to the control room
2. Read out/note the simulated and indicated values and check for linearity

7.3 Switching on the device

Once the final checks have been successfully completed, it is time to switch on the supply voltage. Afterwards the multipoint thermometer is operational. If there are Endress +Hauser temperature transmitter in use, please refer to the enclosed Brief Operating Instructions for commissioning.

8 Diagnostics and troubleshooting

8.1 General troubleshooting

NOTICE

Repair of parts of the device

- ▶ In the event of a serious fault, a measuring device might have to be replaced. In the case of replacement see section 'Return' →  27.
- ▶ It is always important to check the connection between the cables and terminals, in order to guarantee the proper strain relief to the cables, and the tightening and the sealing of the screw terminals.

Before commissioning the measuring system make sure that all final checks have been carried out:

- Follow the checklist in section 'Post-mounting check' →  16
- Follow the checklist in section 'Post-connection check' →  22

If transmitters are used, please refer to the documentation of the transmitter installed for diagnostic and troubleshooting procedures →  41.

9 Repair

9.1 General notes

The accessibility around the device for maintenance has to be guaranteed. Each component that is part of the device must be – in the case of replacement – replaced by an original spare part of Endress+Hauser which guarantees the same characteristics and performance. To ensure continued operational safety and reliability it is suggested to carry out repairs on the device only if they are expressly permitted by Endress+Hauser, observing federal/national regulations pertaining to repair of an electrical device.

9.2 Spare parts

When ordering spare parts, please specify the serial number of the unit!

Spare parts of the Multipoint thermometer assembly are:

- Inserts
- Cable glands
- Transmitters or electrical terminals
- Junction box and related accessories
- Ferrule sets of the compression fittings

9.3 Endress+Hauser services

Service	Description
Certifications	Endress+Hauser is able to fulfill requirements belonging to the design, product manufacturing, tests and commissioning according to specific approvals by handling or supplying individual certified components and by checking the integration on the whole system.
Maintenance	All Endress+Hauser systems are designed for an easy maintenance due to a modular design, allowing the replacement of old or wear out parts. Standardized parts ensure fast reaction for maintenance.
Calibration	Endress+Hauser's range of calibration services covers on-site verification tests, accredited laboratory calibrations, certificates and traceability to ensure compliance.
Installation	Endress+Hauser helps you commission plants while minimizing costs. Fault free installation is decisive for the quality and longevity of the measurement system and plant running. We provide the right expertise at the right time to meet project deliverables.
Tests	In order to ensure product quality and to guarantee efficiency during the entire lifetime the following tests are available: <ul style="list-style-type: none"> ▪ Dye penetration test according to ASME V art. 6, UNI EN 571-1 and ASME VIII Div. 1 App 8 standards ▪ PMI test according to ASTM E 572 ▪ HE test according to EN 13185 / EN 1779 ▪ X-ray test according to ASME V art. 2, art. 22 and ISO 17363-1 (requirements and methods) and ASME VIII div. 1 and to ISO 5817 (acceptance criteria). Thickness up to 30 mm ▪ Hydrostatic test according to PED Directive, EN 13445-5 and harmonized ▪ Ultrasonic test available by qualified external partners, according to ASME V Art. 4

9.4 Return

The measuring device must be returned if it is need of repair or a factory calibration, or if the wrong measuring device has been delivered or ordered. Legal specifications require

Endress+Hauser, as an ISO-certified company, to follow certain procedures when handling products that are in contact with the medium.

To ensure safe, swift and professional device returns, please refer to the procedure and conditions for returning devices provided on the Endress+Hauser website at <http://www.endress.com/support/return-material>

9.5 Disposal

9.5.1 Removing the measuring device

1. Switch off the device.

2. **⚠ WARNING**

Danger to persons from process conditions.

- ▶ Beware of hazardous process conditions such as pressure in the measuring device, high temperatures or aggressive fluids.

Carry out the mounting and connection steps from the chapters "Mounting the measuring device" and "Connecting the measuring device" in the logically reverse sequence. Observe the safety instructions.

9.5.2 Disposing of the measuring device

⚠ WARNING

Danger to personnel and environment from fluids that are hazardous to health.

- ▶ Ensure that the measuring device and all cavities are free of fluid residues that are hazardous to health or the environment, e.g. substances that have permeated into crevices or diffused through plastic.

Observe the following notes during disposal:

- Observe valid federal/national regulations.
- Ensure proper separation and reuse of the device components.

10 Accessories

Various accessories, which can be ordered with the device or subsequently from Endress+Hauser, are available for the device. Detailed information on the order code is available from your local Endress+Hauser sales center.



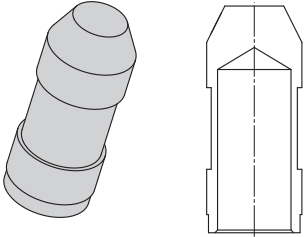
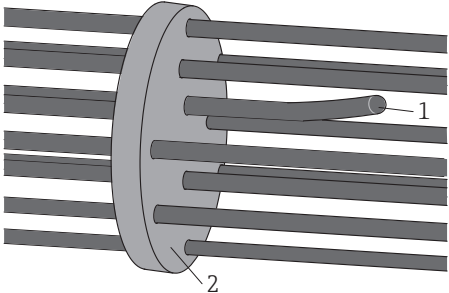
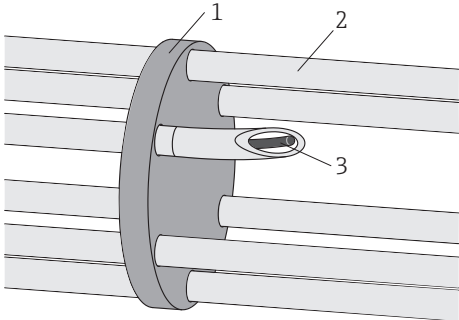

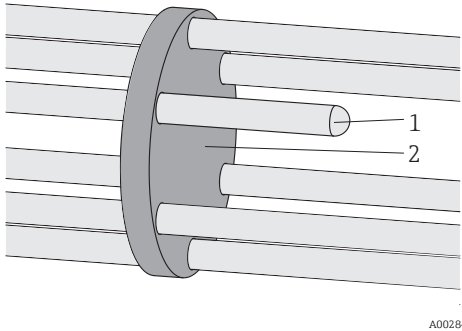
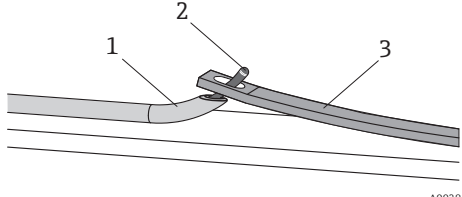
10.1 Device-specific accessories



Accessories	Description
<p style="text-align: center;">Tip end</p>  <p style="text-align: right; font-size: small;">A0028427</p>	<p>Terminal closure welded at the tip end of the probe in order to protect the insert (or the thermowell) from aggressive process conditions and to facilitate its fixing by means of metallic tie wraps.</p>
Thermal contact system	
<p style="text-align: center;">Insert and spacers</p>  <p>1 Insert 2 Spacer</p> <p style="text-align: right; font-size: small;">A0033485</p>	<ul style="list-style-type: none"> ■ Used on straight configurations and in case of an existing thermowell for axial centering of the insert bundle ■ Prevent the twisting of the inserts ■ Give flexural stiffness to the sensor bundle
<p style="text-align: center;">Guiding tubes and spacers</p>  <p>1 Spacer 2 Guiding tube 3 Insert</p> <p style="text-align: right; font-size: small;">A0028783</p>	<ul style="list-style-type: none"> ■ Used on straight configurations and in case of an existing thermowell for axial centering of the insert bundle ■ Give flexural stiffness to the sensor bundle ■ Allow sensor replacement ■ Guarantee thermal contact between the sensor tip and the existing thermowell ■ Modular design ¹⁾

Accessories	Description
<p>Thermowells and spacers</p>  <p style="text-align: right; font-size: small;">A0028434</p> <p>1 Thermowell 2 Spacer</p>	
<p>Bimetallic stripes</p>  <p style="text-align: right; font-size: small;">A0028435</p> <p>10 Bimetal strips with or without guiding tubes</p> <p>1 Guiding tube 2 Insert 3 Bimetallic stripe</p>	<ul style="list-style-type: none"> ▪ Used on straight configurations and inside existing thermowells ▪ Allow sensor replacement ▪ Guarantee thermal contact between the sensor tip and the thermowell due to bimetallic stripes activated by temperature difference ▪ No friction during installation even with already installed sensors

1) Can be mounted in-house or on-site

10.2 Communication-specific accessories

Configuration kit TXU10	Configuration kit for PC-programmable transmitter with setup software and interface cable for PC with USB port Order code: TXU10-xx
Commubox FXA195 HART	For intrinsically safe HART communication with FieldCare via the USB interface.  For details, see "Technical Information" TI00404F
Commubox FXA291	Connects Endress+Hauser field devices with a CDI interface (= Endress+Hauser Common Data Interface) and the USB port of a computer or laptop.  For details, see "Technical Information" TI00405C
HART Loop Converter HMX50	Is used to evaluate and convert dynamic HART process variables to analog current signals or limit values.  For details, see "Technical Information" TI00429F and Operating Instructions BA00371F
Wireless HART adapter SWA70	Is used for the wireless connection of field devices. The WirelessHART adapter can be easily integrated into field devices and existing infrastructures, offers data protection and transmission safety and can be operated in parallel with other wireless networks with minimum cabling complexity.  For details, see Operating Instructions BA061S

Fieldgate FXA320	Gateway for the remote monitoring of connected 4-20 mA measuring devices via a Web browser.  For details, see "Technical Information" TI00025S and Operating Instructions BA00053S
Fieldgate FXA520	Gateway for the remote diagnostics and remote configuration of connected HART measuring devices via a Web browser.  For details, see "Technical Information" TI00025S and Operating Instructions BA00051S
Field Xpert SFX100	Compact, flexible and robust industry handheld terminal for remote configuration and for obtaining measured values via the HART current output (4-20 mA).  For details, see Operating Instructions BA00060S

10.3 Service-specific accessories

Accessories	Description
Applicator	Software for selecting and sizing Endress+Hauser measuring devices: <ul style="list-style-type: none"> Calculation of all the necessary data for identifying the optimum measuring device: e.g. pressure loss, accuracy or process connections. Graphic illustration of the calculation results Administration, documentation and access to all project-related data and parameters over the entire life cycle of a project. Applicator is available: <ul style="list-style-type: none"> Via the Internet: https://wapps.endress.com/applicator On CD-ROM for local PC installation.
W@M	Life cycle management for your plant W@M supports you with a wide range of software applications over the entire process: from planning and procurement, to the installation, commissioning and operation of the measuring devices. All the relevant device information, such as the device status, spare parts and device-specific documentation, is available for every device over the entire life cycle. The application already contains the data of your Endress+Hauser device. Endress+Hauser also takes care of maintaining and updating the data records. W@M is available: <ul style="list-style-type: none"> Via the Internet: www.endress.com/lifecyclemanagement On CD-ROM for local PC installation.
FieldCare	FDT-based plant asset management tool from Endress+Hauser. It can configure all smart field units in your system and helps you manage them. By using the status information, it is also a simple but effective way of checking their status and condition.  For details, see Operating Instructions BA00027S and BA00059S

11 Technical data

11.1 Input

11.1.1 Measured variable

Temperature (temperature linear transmission behavior)

11.1.2 Measuring range

RTD:

Input	Designation	Measuring range limits
RTD as per IEC 60751	Pt100	-200 to +600 °C (-328 to +1 112 °F)

Thermocouple:

Input	Designation	Measuring range limits
Thermocouples (TC) as per IEC 60584, part 1 - using an Endress+Hauser - iTEMP temperature head transmitter	Type J (Fe-CuNi)	-210 to +720 °C (-346 to +1 328 °F)
	Type K (NiCr-Ni)	-270 to +1 150 °C (-454 to +2 102 °F)
	Type N (NiCrSi-NiSi)	-270 to +1 100 °C (-454 to +2 012 °F)
	Type T (Cu-CuNi)	-270 to +370 °C (-454 to +698 °F)
Internal cold junction (Pt100) Cold junction accuracy: ± 1 K Max. sensor resistance: 10 kΩ		
Thermocouples (TC) - flying leads - as per IEC 60584 and ASTM E230	Type J (Fe-CuNi)	-270 to +720 °C (-454 to +1 328 °F), typical sensitivity above 0 °C ≈ 55 µV/K
	Type K (NiCr-Ni)	-270 to +1 150 °C (-454 to +2 102 °F) ¹⁾ , typical sensitivity above 0 °C ≈ 40 µV/K
	Type N (NiCrSi-NiSi)	-270 to +1 100 °C (-454 to +2 012 °F), typical sensitivity above 0 °C ≈ 40 µV/K
	Type T (Cu-CuNi)	-270 to +370 °C (-454 to +698 °F), typical sensitivity above 0 °C ≈ 43 µV/K

1) Limited by jacket material of insert

11.2 Output

11.2.1 Output signal

Generally, the measured value can be transmitted in one of two ways:

- Directly-wired sensors - sensor measured values forwarded without a transmitter.
- Via all common protocols by selecting an appropriate Endress+Hauser iTEMP temperature transmitter. All the transmitters listed below are mounted directly in the junction box and wired with the sensory mechanism.

11.2.2 Family of temperature transmitters

Thermometers fitted with iTEMP transmitters are an installation-ready complete solution to improve temperature measurement by significantly increasing accuracy and reliability, when compared to direct wired sensors, as well as reducing both wiring and maintenance costs.

PC programmable head transmitters

They offer a high degree of flexibility, thereby supporting universal application with low inventory storage. The iTEMP transmitters can be configured quickly and easily at a PC.

Endress+Hauser offers free configuration software which can be downloaded from the Endress+Hauser Website. More information can be found in the Technical Information.

HART® programmable head transmitters

The transmitter is a 2-wire device with one or two measuring inputs and one analog output. The device not only transfers converted signals from resistance thermometers and thermocouples, it also transfers resistance and voltage signals using HART® communication. It can be installed as an intrinsically safe apparatus in Zone 1 hazardous areas and is used for instrumentation in the terminal head (flat face) as per DIN EN 50446. Swift and easy operation, visualization and maintenance by PC using operating software, Simatic PDM or AMS. For more information, see the Technical Information.

PROFIBUS® PA head transmitters

Universally programmable head transmitter with PROFIBUS® PA communication. Conversion of various input signals into digital output signals. High accuracy over the complete ambient temperature range. Swift and easy operation, visualization and maintenance using a PC directly from the control panel, e. g. using operating software, Simatic PDM or AMS. For more information, see the Technical Information.

FOUNDATION Fieldbus™ head transmitters

Universally programmable head transmitter with FOUNDATION Fieldbus™ communication. Conversion of various input signals into digital output signals. High accuracy over the complete ambient temperature range. Swift and easy operation, visualization and maintenance using a PC directly from the control panel, e.g. using operating software such as ControlCare from Endress+Hauser or NI Configurator from National Instruments. For more information, see the Technical Information.

Advantages of the iTEMP transmitters:

- Dual or single sensor input (optionally for certain transmitters)
- Unsurpassed reliability, accuracy and long-term stability in critical processes
- Mathematical functions
- Monitoring of the thermometer drift, sensor backup functionality, sensor diagnostic functions
- Sensor-transmitter matching for dual sensor input transmitter, based on Callendar/Van Dusen coefficients

11.3 Environment

11.3.1 Ambient temperature range

Junction box	Non-hazardous area	Hazardous area
Without mounted transmitter	-50 to +85 °C (-58 to +185 °F)	-50 to +60 °C (-58 to +140 °F)
With mounted head transmitter	-40 to +85 °C (-40 to +185 °F)	Depends on the respective hazardous area approval. Details see Ex documentation.
With mounted multi-channel transmitter	-40 to +85 °C (-40 to +185 °F)	-40 to +70 °C (-40 to +158 °F)

11.3.2 Storage temperature

Junction box	
With head transmitter	-50 to +95 °C (-58 to +203 °F)
With multi-channel transmitter	-40 to +80 °C (-40 to +176 °F)
With DIN rail transmitter	-40 to +95 °C (-40 to +203 °F)

11.3.3 Humidity

Condensation according to IEC 60068-2-33:

- Head transmitter: Permitted
- DIN rail transmitter: Not permitted

Maximum relative humidity: 95% according to IEC 60068-2-30

11.3.4 Climate class

Determined when the following components are installed into the junction box:

- Head transmitter: Class C1 according to EN 60654-1
- Multi-channel transmitter: Tested as per IEC 60068-2-30, meets the requirements regarding class C1-C3 in accordance with IEC 60721-4-3
- Terminal blocks: Class B2 according to EN 60654-1

11.3.5 Degree of protection

- Specification for conduit: IP68
- Specification for the junction box: IP66/67

11.3.6 Electromagnetic compatibility (EMC)

Depending on the head transmitter used. For detailed information see the related Technical Information, listed at the end of this document.

11.4 Mechanical construction

11.4.1 Design, dimensions

The overall multipoint assembly is composed of different sub-assemblies. Both linear and 3D configurations have the same features, dimensions and materials. Different inserts are available, based upon specific process conditions, in order to have the highest accuracy and an extended lifetime. In addition, protecting thermowells can be selected to further increase mechanical performances and corrosion resistance, and to allow insert replacement. Associated shielded extension cables are provided with high resistance sheath materials to withstand different environmental conditions and to ensure steady and noiseless signals. The transition between the inserts and the extension cable is obtained by the usage of specially sealed bushings, ensuring the declared IP degree protection.

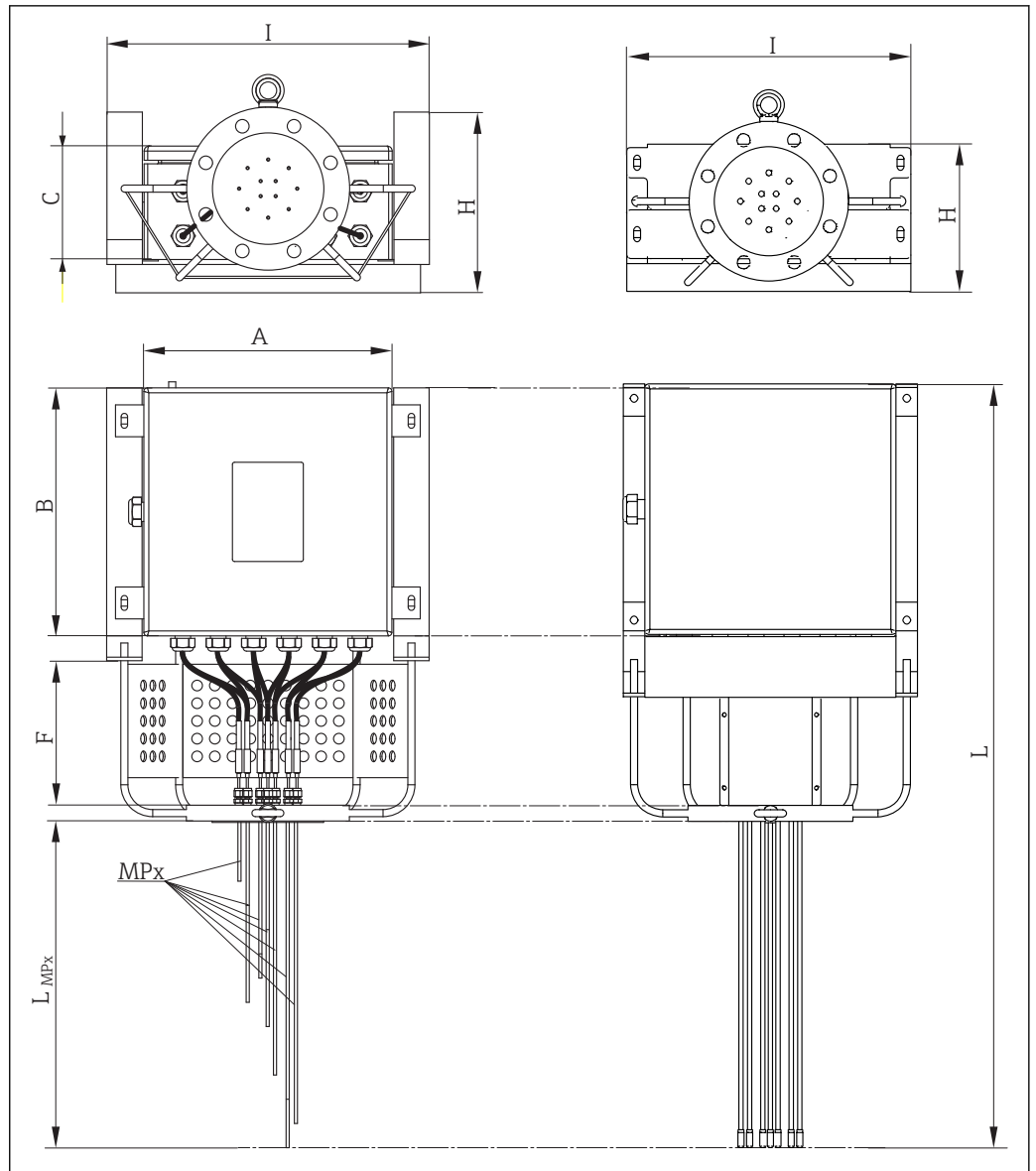

A0028080

11 Design of the modular multipoint thermometer, with frame neck on the left side or with frame neck and covers on the right side. All dimensions in mm (in)

A, B, Dimensions of the junction box, see following figure

C

MPx Numbers and distribution of measuring points: MP1, MP2, MP3 etc.

L_{MPx} Different immersion length of sensing elements or thermowells

I, H Encumbrance of the junction box and support system

F Extension neck length

L Overall device length

Extension neck F in mm (in)

Standard 250 (9.84)

Specifically customized extension necks are available on request.

Immersion lengths MPx of sensing elements/thermowells:

Based on customer requirements

Junction box

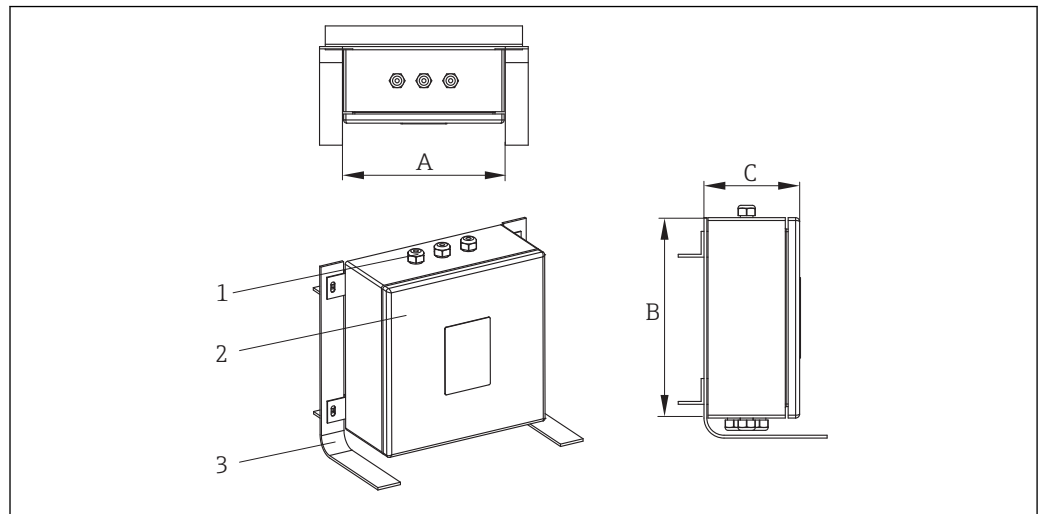

A0028118

- 1 Cable glands
- 2 Junction box
- 3 Frame

The junction box is suited for chemical agents environments. Sea water corrosion resistance and extreme temperature variation stability is guaranteed. Ex-e Ex-i terminals can be installed.

Possible junction box dimensions (A x B x C) in mm (in):

		A	B	C
Stainless Steel	Min.	170 (6.7)	170 (6.7)	130 (5.1)
	Max.	500 (19.7)	500 (19.7)	240 (9.5)
Aluminium	Min.	100 (3.9)	150 (5.9)	80 (3.2)
	Max.	330 (13)	500 (19.7)	180 (7.1)

Type of specification	Junction box	Cable glands
Material	AISI 316	NiCr Plated brass AISI 316 / 316L
Ingress protection (IP)	IP66/67	IP66
Ambient temperature range (ATEX)	-50 to +60 °C (-58 to +140 °F)	-52 to +110 °C (-61.1 to +140 °F)
Approvals	ATEX, FM, UL, CSA approval for use in hazardous area	-
Marking	ATEX II 2GD Ex e IIC/Ex ia Ga IIC Ex tb IIIC Db T6/T5/T4 UL913 Class I, Division 1 Groups B,C,D T6/T5/T4 FM3610 Class I, Division 1 Groups B,C,D T6/T5/T4 CSA C22.2 No.157 Class I, Division 1 Groups B,C,D T6/T5/T4	According to the junction box approval
Cover	Hinged	-
Maximum sealing diameter	-	6 to 12 mm (0.24 to 0.47 in)

Neck extension

The neck extension ensures the connection between the flange and the junction box. The design has been developed to ensure several mounting layouts to deal with possible obstacles and constraints that can be met in any plant such as the reactor's infrastructure (step ways, loading structures, supporting skirts, stairs, etc.) and reactor thermal insulation. The neck extension design ensures easy access for monitoring and maintaining inserts and extension cables. It guarantees a high stiffness connection for the junction box and vibration loads. No closed volumes are present in the neck extension. This avoids the accumulation of waste and potentially dangerous fluids coming from the environment that can damage the instrumentation allowing continuous ventilation.

Insert and thermowells

 Different insert and thermowell types are available. For any different requirement that is not described here, please contact the Endress+Hauser sales department.

Thermocouple

Diameter in mm (in)	Type	Standard	Hot junction type	Sheath material
6 (0.24) 4.5 (0.18) 3 (0.12) 2 (0.08) 1.5 (0.06)	1x type K 2x type K 1x type J 2x type J 1x type N 2x type N 1x type T 2x type T	IEC 60584 / ASTM E230	Grounded/Ungrounded	Alloy600 / AISI 316L

RTD

Diameter in mm (in)	Type	Standard	Sheath material
3 (0.12) 6 (1/4)	1x Pt100 WW 2x Pt100 WW 1x Pt100 TF 2x Pt100 TF	IEC 60751	AISI 316L

Thermowells

External diameter in mm (in)	Sheath material	Type	Thickness in mm (in)
6 (0.24)	AISI 316L or AISI 321 or AISI 347 or Alloy 600	closed or open	1 (0.04) or 1.5 (0.06)
8 (0.32)	AISI 316L or AISI 321 or AISI 347 or Alloy 600	closed or open	1 (0.04) or 1.5 (0.06) or 2 (0.08)
10.2 (1/8)	AISI 316L or AISI 321 or AISI 347 or Alloy 600	closed or open	1.73 (0.068)

11.4.2 Weight

The weight can vary depending on the configuration: Dimension and content of the junction box, neck length, dimensions of process connection and the number of inserts. The approximate weight of a typically configured multipoint thermometer (number of inserts = 12, flange size = 3", medium size junction box) = 40 kg (88 lb)

11.4.3 Materials

It refers to insert sheath, neck extension, junction box and all wetted parts.

The temperatures for continuous operation specified in the following table are only intended as reference values for use of the various materials in air and without any significant compressive load. The maximum operation temperatures are reduced considerably in some cases where abnormal conditions such as high mechanical load occur or in aggressive media.

Material name	Short form	Recommended max. temperature for continuous use in air	Properties
AISI 316/1.4401	X5CrNiMo 17-12-2	650 °C (1202 °F)	<ul style="list-style-type: none"> ▪ Austenitic, stainless steel ▪ High corrosion resistance in general ▪ Particularly high corrosion resistance in chlorine-based and acidic, non-oxidizing atmospheres through the addition of molybdenum (e.g. phosphoric and sulfuric acids, acetic and tartaric acids with a low concentration)
AISI 316L/ 1.4404 1.4435	X2CrNiMo17-12-2 X2CrNiMo18-14-3	650 °C (1202 °F)	<ul style="list-style-type: none"> ▪ Austenitic, stainless steel ▪ High corrosion resistance in general ▪ Particularly high corrosion resistance in chlorine-based and acidic, non-oxidizing atmospheres through the addition of molybdenum (e.g. phosphoric and sulfuric acids, acetic and tartaric acids with a low concentration) ▪ Increased resistance to intergranular corrosion and pitting ▪ Compared to 1.4404, 1.4435 has even higher corrosion resistance and a lower delta ferrite content
Alloy600/ 2.4816	NiCr15Fe	1100 °C (2012 °F)	<ul style="list-style-type: none"> ▪ A nickel/chromium alloy with very good resistance to aggressive, oxidizing and reducing atmospheres, even at high temperatures ▪ Resistance to corrosion caused by chlorine gases and chlorinated media as well as many oxidizing mineral and organic acids, sea water etc. ▪ Corrosion from ultrapure water ▪ Not to be used in sulfur-containing atmospheres
AISI 304/1.4301	X5CrNi18-10	850 °C (1562 °F)	<ul style="list-style-type: none"> ▪ Austenitic, stainless steel ▪ Well usable in water and lowly pollute waste water ▪ Only at relatively low temperatures resistant to organic acids, saline solutions, sulphates, alkaline solutions, etc.
AISI 304L/ 1.4307	X2CrNi18-9	850 °C (1562 °F)	<ul style="list-style-type: none"> ▪ Good welding properties ▪ Impervious to intergranular corrosion ▪ High ductility, excellent drawing, forming, and spinning properties
AISI 316Ti/ 1.4571	X6CrNiMoTi17-12-2	700 °C (1292 °F)	<ul style="list-style-type: none"> ▪ Addition of titanium means increased resistance to intergranular corrosion even after welding ▪ Broad range of uses in the chemical, petrochemical and oil industries as well as in coal chemistry ▪ Can only be polished to a limited extent, titanium streaks can form

Material name	Short form	Recommended max. temperature for continuous use in air	Properties
AISI 321/1.4541	X6CrNiTi18-10	815 °C (1499 °F)	<ul style="list-style-type: none"> ▪ Austenitic stainless steel ▪ High resistance to intergranular corrosion even after welding ▪ Good welding characteristics, suitable to all standard welding methods ▪ It is used in many sectors of the chemical industry, petrochemical, and pressurized vessels
AISI 347/1.4550	X6CrNiNb10-10	800 °C (1472 °F)	<ul style="list-style-type: none"> ▪ Austenitic stainless steel ▪ Good resistance to a wide variety of environments in the chemical, textile, oil-refining, dairy and food industries ▪ Added niobium makes this steel impervious to intergranular corrosion ▪ Good weldability ▪ Main applications are furnace fire walls, pressure vessels, welded structures, turbine blades

11.4.4 Process connection

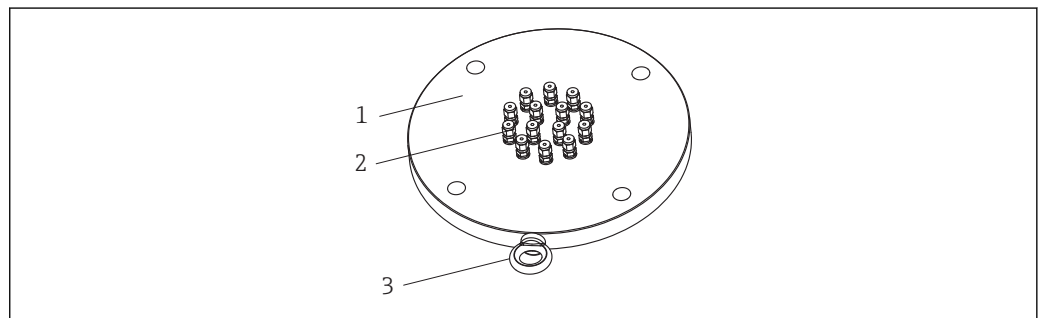

A0028122

12 Flange as process connection

- 1 Flange
- 2 Compression fittings
- 3 Eyebolt

Standard process connection flanges are designed according to the following standards:

Standard ¹⁾	Size	Rating	Material
ASME	1½", 2", 3", 4", 6", 8"	150#, 300#, 600#	AISI 316, 316L, 304, 304L, 316Ti, 321, 347
EN	DN40, DN50, DN80, DN100, DN150, DN200	PN10,PN16, PN40, PN63, PN100	

1) Flanges according to GOST standard are available on request.

Compression fittings

The compression fittings are welded or threaded into the flange to ensure tightness to the process connection. Dimensions are coherent with the insert dimensions. Compression fittings comply with the highest standards of reliability in terms of materials and performances required.

Material	AISI 316/316H
----------	---------------

11.5 Certificates and approvals

11.5.1 CE Mark

The complete assembly is provided with individual components CE marked, to ensure safe use in hazardous areas and pressurized environments.

11.5.2 Hazardous area approvals

The Ex approval applies to individual components like junction box, cable glands, terminals. For further details on the available Ex versions (ATEX, UL, FM, CSA, IEC-EX, NEPSI, EAC-EX), please contact your nearest Endress+Hauser sales organization. All relevant data for hazardous areas can be found in separate Ex documentation.

ATEX Ex ia inserts are available only for diameters ≥ 1.5 mm (0.6 in). For further details contact an Endress+Hauser technician.

11.5.3 Certification HART

The HART[®] temperature transmitter is registered by the FieldComm Group. The device meets the requirements of the HART[®] Communication Protocol Specifications.

11.5.4 Certification FOUNDATION Fieldbus

The FOUNDATION Fieldbus[™] temperature transmitter has successfully passed all test procedures and is certified and registered by the Fieldbus Foundation. The device thus meets all the requirements of the following specification:

- Certified according to FOUNDATION Fieldbus[™] specification
- FOUNDATION Fieldbus[™] H1
- Interoperability Test Kit (ITK), up to date revision status (device certification no. available on request): the device can also be operated with certified devices of other manufacturers
- Physical layer conformance test of the FOUNDATION Fieldbus[™]

11.5.5 Certification PROFIBUS[®] PA

The PROFIBUS[®] PA temperature transmitter is certified and registered by the PNO (PROFIBUS[®] Nutzerorganisation e. V.), PROFIBUS user organization. The device meets all the requirements of the following specifications:

- Certified according to FOUNDATION Fieldbus[™] specification
- Certified in accordance with PROFIBUS[®] PA Profile (the up to date profile version is available on request)
- The device can also be operated with certified devices of other manufacturers (interoperability)

11.5.6 Other standards and guidelines

- EN 60079: ATEX certification for hazardous areas
- IEC 60529: Degree of protection of housing (IP code)
- IEC 60584 and ASTM E230/ANSI MC96.1: Thermocouples

11.5.7 Material certification

The material certificate 3.1 (according to EN 10204) can be requested separately. The certificate includes a declaration related to the materials used to produce the thermometer. It guarantees the traceability of the materials through the identification number of the multipoint thermometer.

11.5.8 Test report and calibration

The "Factory calibration" is carried out according to an internal procedure in a laboratory of Endress+Hauser accredited by the European Accreditation Organization (EA) to ISO/IEC 17025. A calibration which is performed according to EA guidelines (SIT/Accredia) or (DKD/DAkkS) may be requested separately. The calibration is performed on the inserts of the multipoint.

11.6 Documentation

- Operating manuals iTEMP temperature transmitters:
 - TMT180, PC-programmable, single-channel, Pt100 (KA00118R/09/a3)
 - TMT181, PC programmable, single-channel, RTD, TC, Ω , mV (KA141R/09/a3)
 - HART[®] TMT182, single-channel, RTD, TC, Ω , mV (KA142R/09/c4)
 - HART[®] TMT82, two-channel, RTD, TC, Ω , mV (BA01028T/09/en)
 - PROFIBUS[®] PA TMT84, two-channel, RTD, TC, Ω , mV (BA00257R/09/en)
 - FOUNDATION Fieldbus[™] TMT85, two-channel, RTD, TC, Ω , mV (BA00251R/09/en)
 - FOUNDATION Fieldbus[™] TMT125, 8 channel, RTD, TC, Ω , mV (BA00240R/09/en)
- Technical Information of inserts:
 - Resistance thermometer insert Omnigrad T TST310 (TI00085T/09/en)
 - Thermocouple insert Omnigrad T TSC310 (TI00255t/09/en)
- Technical Information application example:
 - RN221N active barrier, for supplying loop-powered 2-wire transmitters (TI073R/09/en)
 - HAW562 surge arresters, (TI01012K/09/en)

www.addresses.endress.com
