



User Maintenance Manual/Handbook

Issue 1.01

Firmware version 1.00+

**Isothermal Technology Limited, Pine Grove, Southport, PR9 9AG, England**

**Tel: +44 (0)1704 543830 Fax: +44 (0)1704 544799 Internet: [www.isotech.co.uk](http://www.isotech.co.uk) E-mail: [info@isotech.co.uk](mailto:info@isotech.co.uk)**

The company is always willing to give technical advice and assistance where appropriate. Equally, because of the programme of continual development and improvement we reserve the right to amend or alter characteristics and design without prior notice. This publication is for information only.

# CONTENTS

<b>1</b>	<b>INTRODUCTION</b> .....	<b>4</b>
1.1	UNPACKING .....	5
1.2	SAFETY .....	6
1.3	A QUICK TOUR OF YOUR MILLISKANNER.....	7
<b>2</b>	<b>USING YOUR MILLISKANNER</b> .....	<b>10</b>
2.1	POWERING UP YOUR MILLISKANNER.....	10
2.2	CONNECTING A SINGLE MILLISKANNER TO A MILLIK .....	12
2.3	CONNECTING MULTIPLE MILLISKANNERS TO A MILLIK.....	14
2.4	CONNECTING MILLISKANNERS TO OTHER INSTRUMENTS.....	16
2.5	CONTROLLING MILLISKANNER MANUALLY.....	19
<b>3</b>	<b>CONNECTING THERMOMETER SENSORS</b> .....	<b>21</b>
3.1	THE BINDING POSTS .....	21
3.2	CONNECTING PRTS (4-WIRE) .....	21
3.3	CONNECTING PRTS (3-WIRE) .....	21
3.4	CONNECTING PRTS (2-WIRE) .....	22
3.5	CONNECTING THERMOCOUPLES .....	24
3.5.1	<i>Connecting Thermocouples (using an ice point)</i> .....	24
3.5.2	<i>Connecting Thermocouples (using external compensation)</i> .....	25
3.5.3	<i>Connecting Thermocouples (using internal compensation)</i> .....	26
3.6	CONNECTING THERMISTORS.....	27
<b>4</b>	<b>GOOD PRACTICE GUIDELINES</b> .....	<b>29</b>
4.1	LOOKING AFTER YOUR MILLISKANNER .....	29
4.2	MAKING A GOOD ELECTRICAL MEASUREMENT .....	29
<b>5</b>	<b>THE MILLISKANNER TECHNOLOGY</b> .....	<b>32</b>
5.1	MINIMISING THERMAL EMFS .....	32
5.2	SOLID-STATE SWITCHING .....	33
<b>6</b>	<b>CALIBRATION</b> .....	<b>34</b>
6.1	BEFORE YOU CHECK THE CALIBRATION.....	34
6.2	CHECKING THE REFERENCE JUNCTION SENSOR.....	34
6.3	ADJUSTING THE REFERENCE JUNCTION SENSOR.....	36
<b>7</b>	<b>UPDATING FIRMWARE</b> .....	<b>38</b>
<b>8</b>	<b>RS232 INTERFACE</b> .....	<b>41</b>
8.1	ESTABLISHING AN RS232 CONNECTION.....	41
8.2	SCPI COMMAND SET.....	44
8.2.1	<i>SCPI Command Structure</i> .....	45
8.2.2	<i>SCPI Numeric Suffices</i> .....	47

8.2.3	Parameters.....	47
8.2.4	Controlling the milliskanner Using the RS232 Port.....	47
8.2.5	Terminology - Inputs and Channels.....	48
8.2.6	SCPI Commands.....	49
8.2.6.1	Command: REMote.....	50
8.2.6.2	Command: LOCal.....	50
8.2.6.3	Command: *IDN?.....	50
8.2.6.4	Command: *RST.....	51
8.2.6.5	Command: [ROUte:]CLOSe#.....	51
8.2.6.6	Command: [ROUte:]CLOSe?.....	51
8.2.6.7	Command: [ROUte:]OPEN[:ALL].....	51
8.2.6.8	Command: MILLiskanner:LIST?.....	52
8.2.6.9	Command: MILLiskanner:INITialise.....	52
8.2.6.10	Command: MILLiskanner:START?.....	53
8.2.6.11	Command: MILLiskanner:CLOSe.....	53
8.2.6.12	Command: MILLiskanner:OPEN.....	53
8.2.6.13	Command: MILLiskanner:RJC:OFFSet#?.....	54
8.2.6.14	Command: MILLiskanner:RJC:TEMPerature#?.....	54
8.2.6.15	Command: MILLiskanner:RST.....	54
8.2.6.16	Command: MEASure:RJC?.....	54
8.2.6.17	Command: CALibrate:RJC:OFFSet.....	55
8.2.6.18	Command: CALibrate:RJC:OFFSet?.....	55
8.2.6.19	Command: CALibrate:PASSword.....	55
8.2.6.20	Command: CALibrate:UNLock.....	56
8.2.6.21	Command: CALibrate:LOCK.....	56
8.2.6.22	Command: FIRMWare:LOADer.....	56
<b>9</b>	<b>SPECIFICATION.....</b>	<b>58</b>
<b>10</b>	<b>APPROVALS.....</b>	<b>59</b>
10.1	CE DECLARATION.....	59
10.2	FCC STATEMENT.....	59
10.3	STANDARDS APPLIED.....	60
<b>11</b>	<b>REVISION HISTORY.....</b>	<b>61</b>

## 1 Introduction

The millisKanner multiplexer can be connected to your milliK Precision Thermometer to increase the number of input channels for any combination of PRT, thermocouple or thermistor sensors. Each multiplexer has 8 input channels and up to 4 millisKanners can be connected to a single milliK, providing you with up to 33 measurement channels. The millisKanner includes features that enable you to make the most accurate measurements possible with your milliK. When you connect the multiplexer to your milliK, the additional channels appear automatically on your milliK and can be configured and used in exactly the same way as the milliK's own input channels, so you can get on with making measurements rather than worrying about how to control your multiplexer.

Each channel is provided with 5 binding posts (for connection to a PRT or thermistor sensor with bare-wire, 4mm plugs or spade connections) and a miniature thermocouple connector. The output from the millisKanner is connected to Channel 2 of the milliK (Channel 1 remains available). Each channel can be configured for use with PRTs, thermocouples or thermistors giving you complete freedom when configuring your system. Channel selection would normally be controlled by the milliK (via the RS232 interface), but manual control is also supported with the left/right buttons on the touch panel.

The millisKanner uses the latest semiconductor technology to implement channel switching rather than the mechanical relays that are commonly used in multiplexers. This completely solid-state design makes the millisKanner highly reliable. The sense input reversal (used to eliminate the effect of thermal EMFs on thermocouple measurements) and internal reference junction sensor used in the milliK are reproduced in the

millisKanner. This means that measurements made using the millisKanner meet the same uncertainty specification as those made with the milliK directly. The millisKanner does not provide keep-warm currents, if this is required for a thermometer it should be connected directly to the milliK.

This manual provides a comprehensive guide to using your millisKanner. We recognise that you will probably not wish to read it through at this time so suggest you read the safety section below, turn to Section 2.2 (to learn how to connect the millisKanner to your milliK) and then refer back to the manual using the list of contents to find additional information as required.

## *1.1 Unpacking*

Your millisKanner product should comprise the following items:

- ‡ millisKanner multiplexer
- ‡ a universal power supply with interchangeable plug heads
- ‡ RS232 null modem cable
- ‡ analogue link cable
- ‡ this user manual

If you have ordered a millisKanner to add to an existing millisKanner system, the power supply is replaced by a power lead and the analogue link cable is replaced by a millisKanner-to-millisKanner link cable.

If any item is missing or damaged, please report this immediately to your supplier. If possible, we recommend that you retain the packaging material in case you need to return the instrument for calibration or service since it has been designed to ensure that your millisKanner is properly protected during transportation.

## 1.2 Safety

The millisKanner is a precision instrument, designed for use in a laboratory. It complies with the requirements of safety standard EN61010-1 (2010) and is therefore safe to use in laboratory or light industrial environments. It is not intended for use outdoors or in extreme environments (refer to specification in Section 9).



The millisKanner is likely to be connected to thermometer sensors in use and the operator should take care to ensure that the complete system is safe. For example, metal sheathed thermometers may be connected to the millisKanner and then placed in a furnace powered from a 230V electrical supply. Single fault conditions in such a furnace could lead to the thermometer wires and therefore the binding posts and output connectors of the millisKanner becoming electrically live and therefore a hazard to the operator. Suitable precautions should be taken, such as using an isolating transformer in the supply to such a furnace. If you require further advice on safety issues, please contact Isothermal Technology or one of our appointed distributors – we have extensive experience of thermometry and can provide advice and equipment to help you.

Retain these instructions. Use only as specified in these operating instructions or the intrinsic protection may be impaired.

Please observe the following safety precautions:

- ⌚ Do not use your millisKanner if it is damaged
- ⌚ Connect only to a power supply with a voltage corresponding to that on the power supply label (also given in the specification – see Section 9)
- ⌚ This equipment is for indoor use and will meet its performance figures within an ambient temperature range of 5°C to 40°C with maximum relative humidity of 80%

for temperatures up to 31°C decreasing linearly to 50% RH at 40°C

- ⌚ Equipment is for operation at installation category II (transient voltages) and pollution degree II in accordance with IEC 664 at altitudes up to 2000 metres
- ⌚ Always use the power supply supplied
- ⌚ This equipment is for use in moderate climates only. NEVER use the equipment in damp or wet conditions
- ⌚ Avoid excessive heat, humidity, dust & vibration
- ⌚ Do not place liquid filled containers on the equipment
- ⌚ Do not use where the equipment (or any associated accessories) may be subjected to dripping or splashing liquids
- ⌚ Ensure that the switch on the electrical supply outlet used is easily accessible to allow the unit to be switched off
- ⌚ Ensure that tabletop equipment is placed on a solid, level surface, which is able to support its weight (and that of any attached accessories)
- ⌚ Ensure all cables and wires are routed safely to avoid tripping: also to avoid sharp bends and pinches
- ⌚ Clean only with a damp cloth. Do not wet or allow moisture to penetrate the unit. Do not use solvents. See section 4.1 for details of cleaning procedure
- ⌚ The product should be subjected to regular in-service inspections as required by local regulations; a yearly interval is suggested
- ⌚ Do not apply earth test currents to any terminal/connector or to the shrouds of the RS232 connectors
- ⌚ This equipment contains no user-serviceable parts. Refer all repairs to qualified service personnel. Contact Isothermal Technology or one of our appointed distributors for details of approved service outlets

### ***1.3 A Quick Tour of Your millisKanner***

On the top panel of your millisKanner you will find the binding posts (five per channel) and miniature thermocouple connectors for the eight inputs channels , the “left”/”right” channel select buttons, the green “power” LED and eight red LEDs that indicate when a channel is selected:

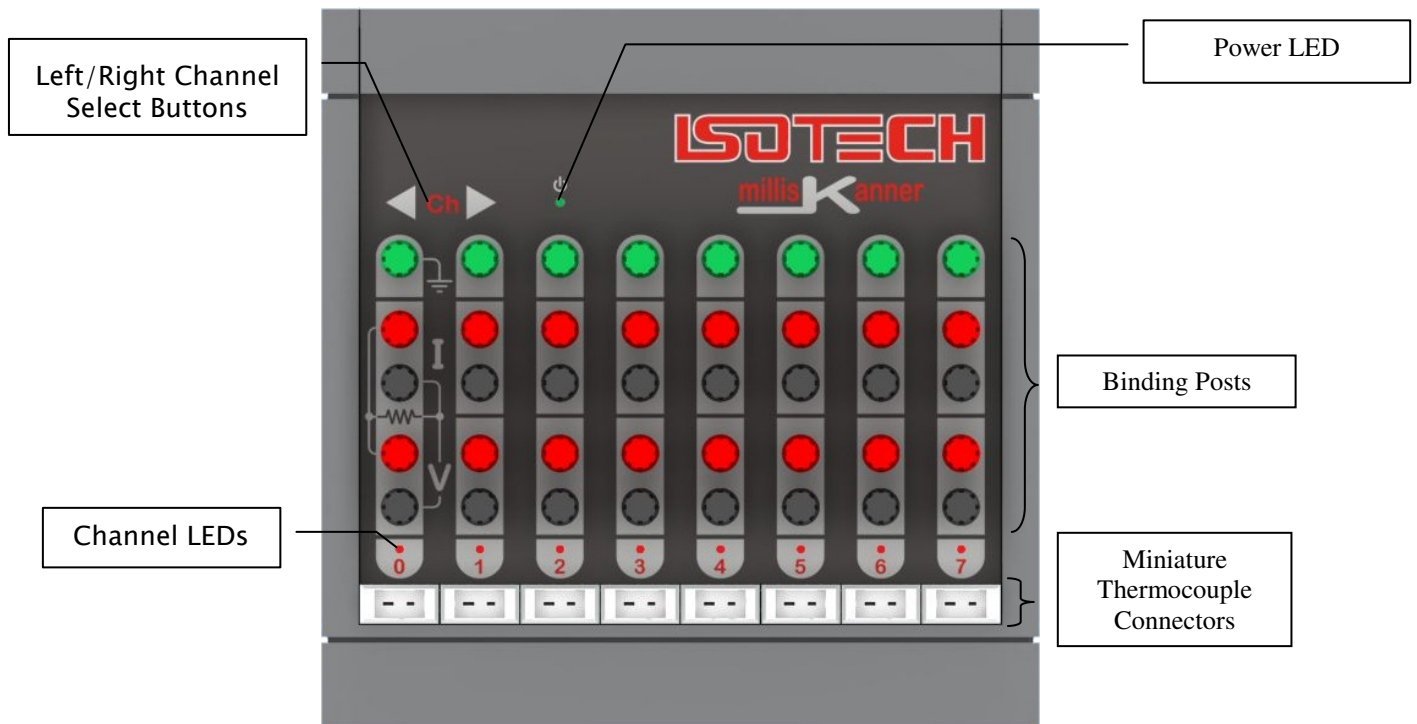

On the rear panel you will find the 5 output connectors (4mm sockets), two RS232 ports and two DC power inlets (for 5V DC). Two RS232 and power inlets are provided in order to allow millisKanners to be “daisy-chained” together. The unused RS232 port on the last millisKanner in your system can be connected to a PC in order to control the whole measurement system using your own software (see section 8). The command protocol employs the widely used SCPI format (see section 8.2 for details)::

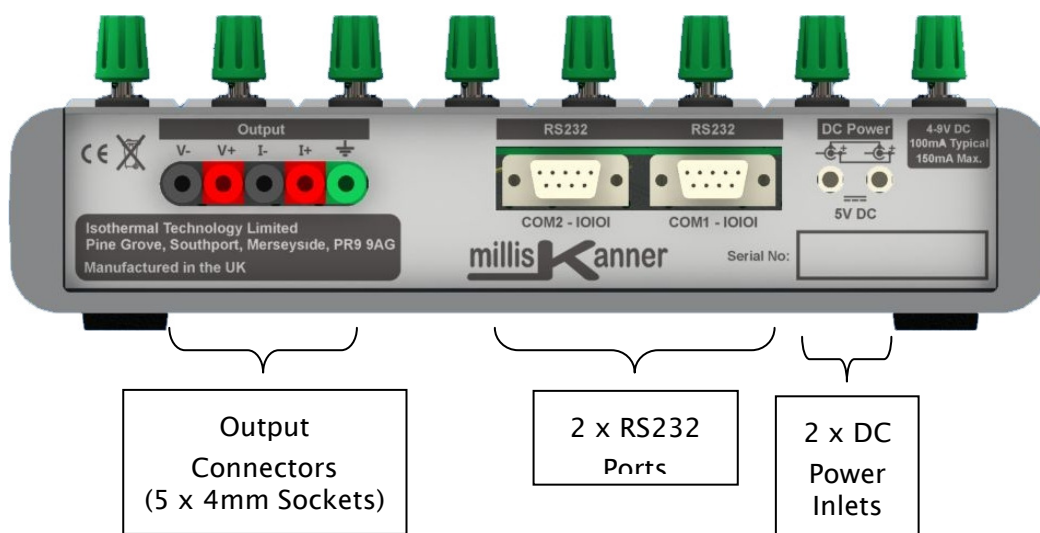



The binding posts accept 4mm plugs, spades or bare wires. The current (I) and voltage sense (V) terminals are spaced on 19mm ( $\frac{3}{4}$ " ) centres so that standard BNC to 4mm adaptors (not supplied) can be used to connect to thermometer sensors that have BNC terminations

## 2 Using your millisKanner

Your millisKanner is very easy to use, simply connect it to your milliK Precision Thermometer (analogue and RS232 connections) and apply power to both instruments. On power-up, the milliK ‘discovers’ any millisKanners connected to it and assigns channel numbers to each input. These additional channels then appear in the list of channels and can be configured and used in the same way as the existing channels on the milliK.

The automatic discovery process takes place during initialisation of the milliK software and requires the RS232 connection(s) to be present (see sections 2.2 or 2.3). If you connect or power the millisKanner after the milliK software has initialised (at the initial screen with the *Start* button, or later), press the *Restart/Update Software* button on the  *Instrument* screen of the milliK to re-invoke the discovery process.

A millisKanner will only work with a milliK that is running with firmware version 1.11 or above and software version 1.5.4 or above. The firmware and software versions are shown on the milliK in the opening screen (with the *Start* button). If your milliK is running with older firmware or software, please contact Isothermal Technology or one of our appointed distributors to arrange an upgrade. The hardware on all milliKs is compatible with millisKanner multiplexers.

### 2.1 *Powering Up Your millisKanner*

The power supply operates from any standard AC electrical supply (90–264V RMS at 47–63Hz), so unless your supply is unusual you can simply connect the power supply to a suitable electrical outlet.

The power supply is fitted with a standard BS 1363 plug head but is provided with alternative heads that cover the majority of electrical sockets used worldwide. If you need to connect to an outlet socket that is not supported by the plug heads provided you should source a suitable electrical supply lead locally that is fitted with a C8 connector, you can then plug this directly into the C8 socket on the power supply. The plug head can easily be changed:

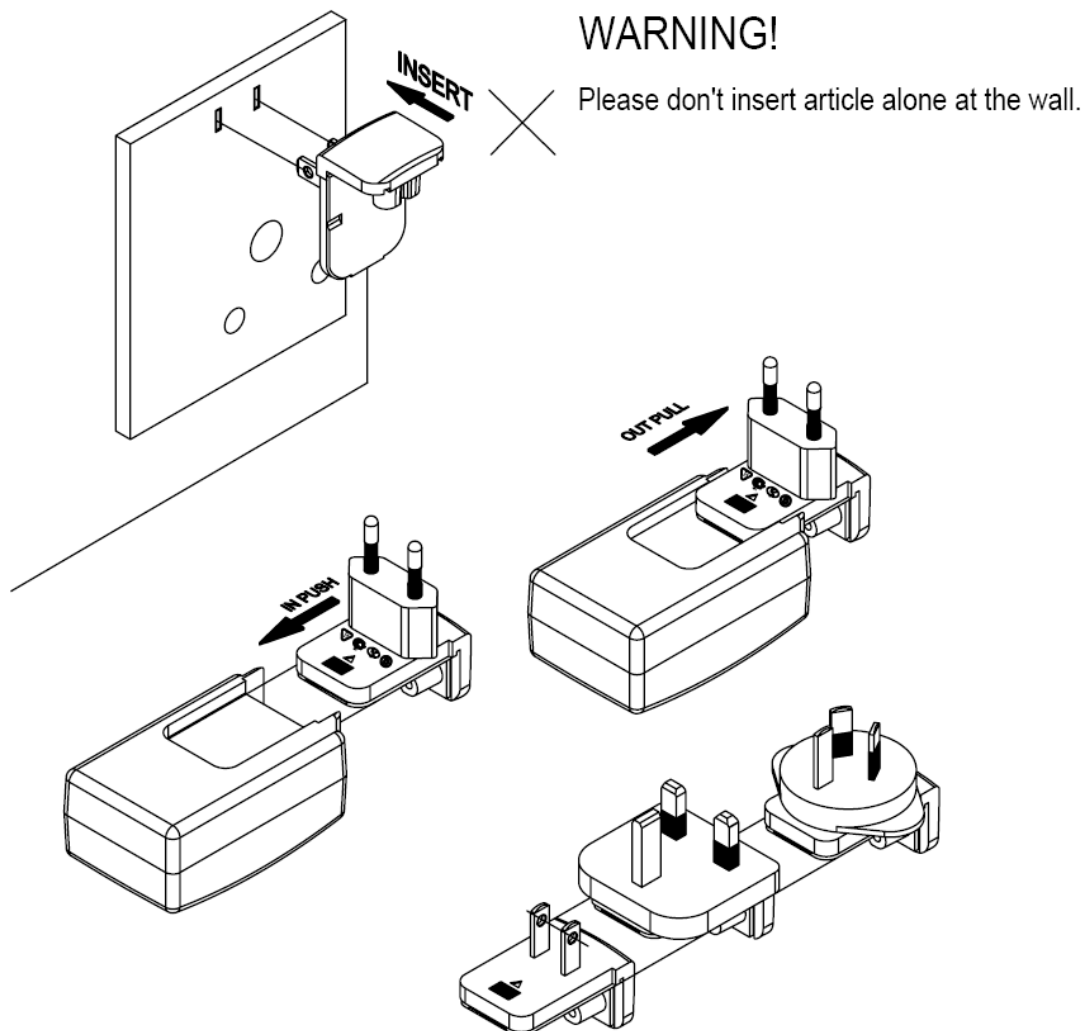

Plug the DC connector from the power supply into either of the “DC Power” sockets on the rear of the millisKanner.

## 2.2 Connecting a Single millisKanner to a milliK

Using the null modem cable provided (see section 8.1 if you wish to make your own cable), connect either of the RS232 ports on the millisKanner to either RS232 port on the rear of the milliK (it does not matter which port is used as they are completely interchangeable). Connect the five Output Terminals on the rear of the millisKanner to Channel 2 of the milliK, using the link cable provided, carefully observing the colour coding shown (note: the white wires must be connected to the V+ /V- terminals):

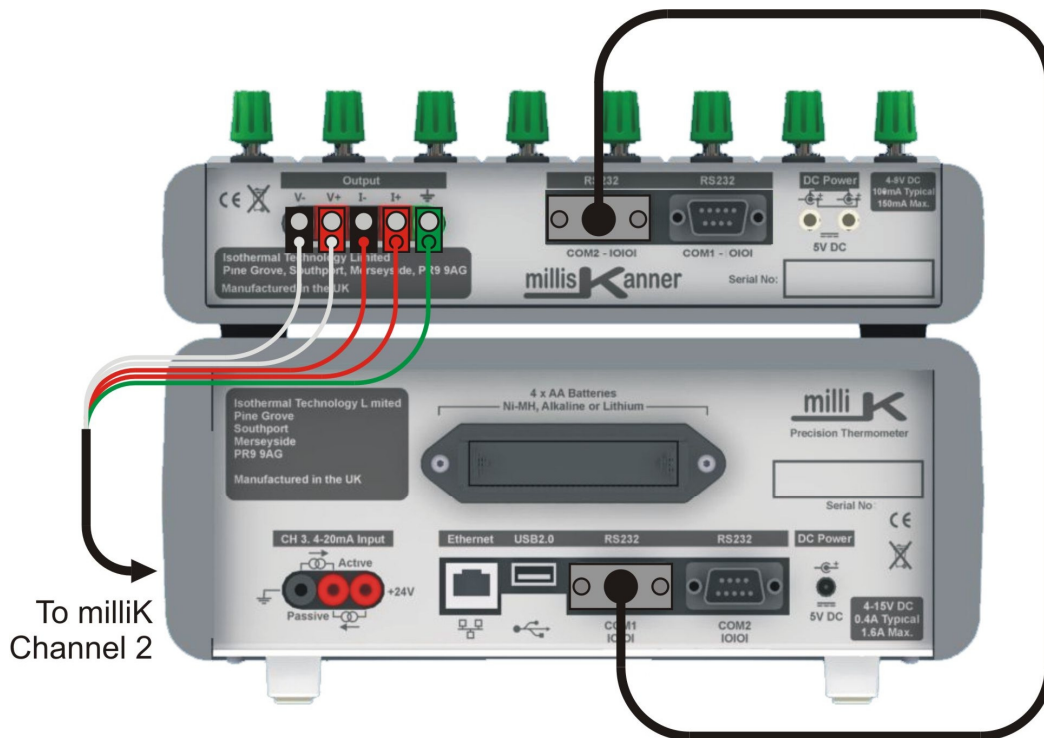

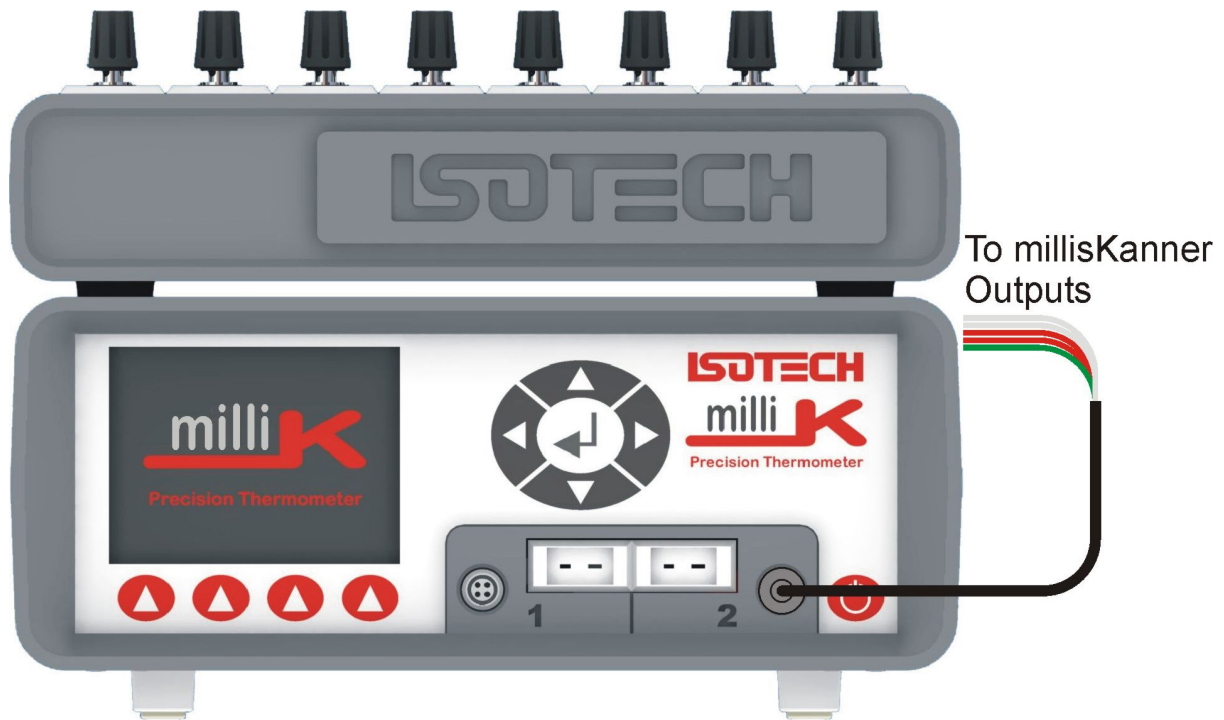

**Note the scanner output must be connected to Channel 2 of the milliK**

millisKanner Output	Plug Colour	Wire Colour
V-	Black	White
V+	Red	White
I-	Black	Red
I+	Red	Red
⊕	Green	Green

N.B. You must use correct plug colour AND wire colour when making the connections.

If you wish to make your own interconnecting cable, use a screened cable with low dielectric loss insulation such as PTFE or polyethylene (otherwise measurement performance may be affected). The screen should be connected to the (green) ground connector of the millisKanner and shell of the Lemo connector. The pin-out used for the Lemo connectors (looking into the solder buckets) is:

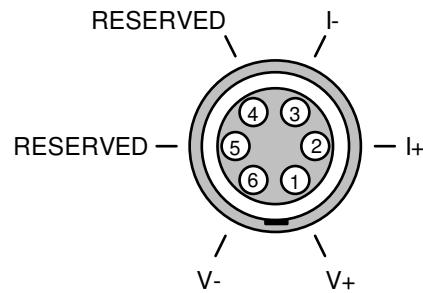

If the software on the milliK is already running, restart it by cycling the power or pressing the [Restart/Update Software](#) button on the [Instrument](#) screen. This initiates the automatic discovery process so that the milliK can detect any millisKanners connected to it and assign channel numbers. The milliK will disable Channel 2, since it is always used as the expansion channel input.

With a single millisKanner, the milliK assigns channel numbers 10 to 17 to the multiplexer. The numbers (0 to 7) below each set of input terminals on the millisKanner help to identify the terminals for each Channel (for example, the input marked as 4 is Channel 14). The red LED (below the terminal posts) will light when measurements are being made on that channel.

If you want to control the measurement system (milliK and millisKanner) from a PC, connect the unused RS232 port on the millisKanner to a PC using a null modem cable. You can still communicate with the milliK even though there is no physical connection to it as the millisKanner will relay commands from the PC to the milliK and will relay back responses from the milliK to the PC (see section 8 for further details).

### ***2.3 Connecting Multiple millisKanners to a milliK***

You may connect up to four millisKanners to a single milliK, giving a maximum of 33 input channels (channel 1 on the milliK and channels 10 to 17, 20 to 27, 30 to 37 and 40 to 47 via millisKanners). The first millisKanner in a system is supplied with an analogue

link cable terminated with a Lemo connector and a universal power supply. Additional millisKanners are provided with analogue link cables terminated with stackable 4mm plugs at both ends and a DC power link cable so that you can create the required expanded system.

First connect a single millisKanner to your milliK (see section 2.2 above). Use the null modem cable provided (see section 8.1 if you wish to make your own cable) to connect the unused RS232 port on the rear of additional millisKanners to the unused RS232 port on the previous millisKanner to form a 'daisy-chain' arrangement. The RS232 ports on the millisKanner are completely interchangeable, so it does not matter which is used to connect to the next millisKanner or the milliK in the system. Similarly, use the Power Link cable provided to connect either DC Power connector on the millisKanner to the unused DC Power connector on the previous millisKanner in a 'daisy-chain' arrangement. Connect the five Output Terminals on the additional millisKanners (in parallel) to the first millisKanner (the analogue cables provided use plugs that allow "piggy-back" connection to make this easy):

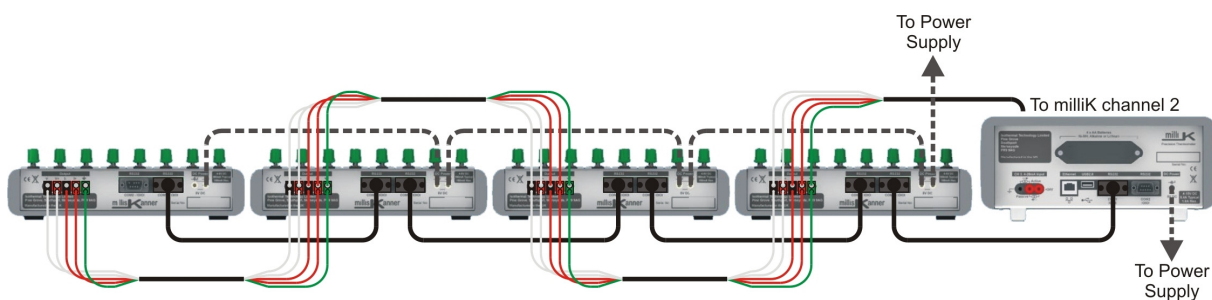

If you wish to make your own analogue link cables, use a screened cable with low dielectric loss insulation such as PTFE or polyethylene (otherwise measurement performance may be affected). The screen should be connected to the ground terminals on both millisKanners.

If the software on the milliK is already running, restart it by cycling the power or pressing the *Restart/Update Software* button on the *Instrument* screen. This initiates the automatic discovery process so that the milliK can detect any millisKanners connected to it and assign channel numbers. The milliK will disable Channel 2, since it is always used as the expansion channel input.

With multiple millisKanners, the milliK assigns channel numbers 10 to 17 to the multiplexer connected directly to it. It then assigns channels numbers 20–27 to the next multiplexer and so on. This means that the channel marked 7 on the third millisKanner in the ‘daisy-chain’ of RS232 connections will be assigned channel number 37. The red LED (below the binding posts) will light when measurements are being made on that channel.

If you want to control the measurement system (milliK and millisKanners) from a PC, connect the unused RS232 port on the millisKanner at the end of the ‘daisy-chain’ to a PC using a null modem cable. You can still communicate with the milliK even though there is no physical connection to it as the millisKanners will relay commands from the PC to the milliK and will relay back responses from the milliK to the PC (see section 8 for further details).

## ***2.4 Connecting millisKanners to Other Instruments***

Although the millisKanner has been designed specifically to work with the milliK Precision Thermometer, it can be used with any other compatible instrument. The only requirement for compatibility is that the instrument must be able to accommodate the series resistance of the millisKanner, which is 5Ω (maximum) in series with each line. The switching devices are rated at 0.5A and 60V (across open contacts), so should be compatible with most thermometry instruments. The millisKanner is designed to switch



low-level signals, never use it to switch currents other than PRT/thermistor sense currents or voltages above 60V.

The reference junction temperature is measured by a digital sensor and is only available via the RS232 interface. If you wish to use internal reference junction compensation, you will need to access the reference junction temperature via the RS232 interface using the *MEAS:RJC?* command (see section 8.2.6.16) or the *MILL:RJC:TEMP#?* command (see section 8.2.6.14).

Make up your own (screened) cable to connect the five output terminals on the rear of the millisKanner to your instrument. Select channels using the RS232 interface (see section 8) or manually (see section 2.5).

If you are controlling the millisKanner using the RS232 interface and making voltage measurements (for thermocouples), make two measurements with opposite polarity (using *CLOS# POS* and *CLOS# NEG* commands) and calculate half the (signed) difference between the measurements in order to eliminate the effect of thermal EMFs generated in the connection between the millisKanner and the instrument. This uses the internal sense reversal feature of the millisKanner to make the highest accuracy voltage measurement. If you do not use this feature, or are controlling the millisKanner manually (see section 2.5) you should use good quality, low thermal EMF connectors to connect between the millisKanner and the instrument. The following Multi Contact 4mm stackable plugs are recommended for the connection to the millisKanner:

Colour	Multi Contact Part Number	Farnell Stock Code
Black	22.2643-21	1085430
Red	22.2643-22	1085431
Green	22.2643-25	1085432

These readily available internationally from Farnell Electronics and can be ordered via their website [www.farnell.com](http://www.farnell.com)

If a command is sent to the millisKanner to change channels, it returns a <CR> (carriage return) when the change has been made. Any software you write should take advantage of this feature and wait for the change to be acknowledged before making a measurement as this will ensure that erroneous measurements are not made during a transition.

## 2.5 Controlling millisKanner Manually

Control your millisKanner manually using the ‘Left’ and ‘Right’ buttons on the top panel:

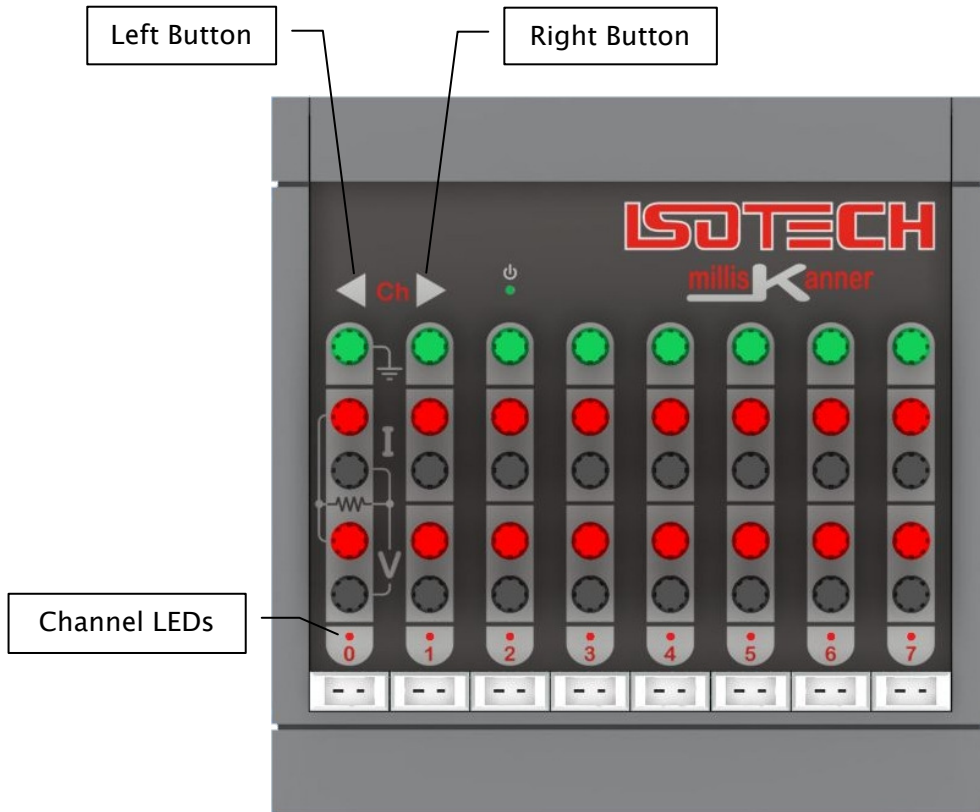

The millisKanner starts up with no channel selected. Pressing the ‘Right’ button will then select Channel 0. Press the ‘Right’ button when Channel 7 is selected or the ‘Left’ button when Channel 0 is selected to turn off all channels. The ‘Channel LEDs’ indicate which channel is selected.

When the millisKanner is connected to a milliK, the left/right buttons no longer operate because the milliK sends the *REM* (see section 8.2.6.1) command to disable local control of the millisKanner. To re-enable the left/right buttons, either send the *LOC* command (see section 8.2.6.2) to the RS232 port or cycle the power to the instrument.

The millisKanner can be used manually with the milliK (do not connect it to the milliK with the RS232 cable so that it is not detected by the milliK) or with another compatible thermometer instrument. In both cases, the feature that reverses the sense connections inside the millisKanner (to eliminate the effect of thermal EMFs generated in the wires

and connectors between the millisKanner and the instrument) does not operate. This means that the voltage offset will be higher than when it is used with a milliK although it should be well within the  $\pm 2\mu\text{V}$  specification of the milliK provided good quality (low thermal EMF) connectors are used.

### 3 Connecting Thermometer Sensors

#### 3.1 The Binding Posts

The binding posts accept 4mm plugs, bare wires or spade terminations. Additionally, they are spaced on 19mm (¾”) pitch so that they can be used with standard 4mm-to-BNC adaptors (not supplied) for connecting to BNC terminated PRTs.

#### 3.2 Connecting PRTs (4-wire)

Your millisKanner is optimised for high accuracy, 4-wire resistance measurement. The PRT should be connected to the chosen input channel, as follows:

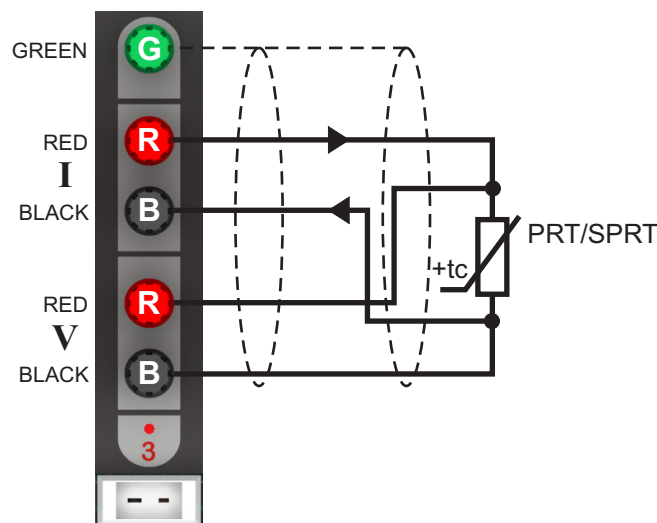

The top (green) terminal should be connected to the screen of the PRT’s lead (where present) to minimise electrical noise picked up by the wires.

#### 3.3 Connecting PRTs (3-wire)

The millisKanner can be connected to 3-wire PRTs and will provide automatically compensate for cable resistance. The two positive (red) terminals should be connected together and the ‘single’ end of the 3-wire PRT should then be connected to the I+ terminal as follows:



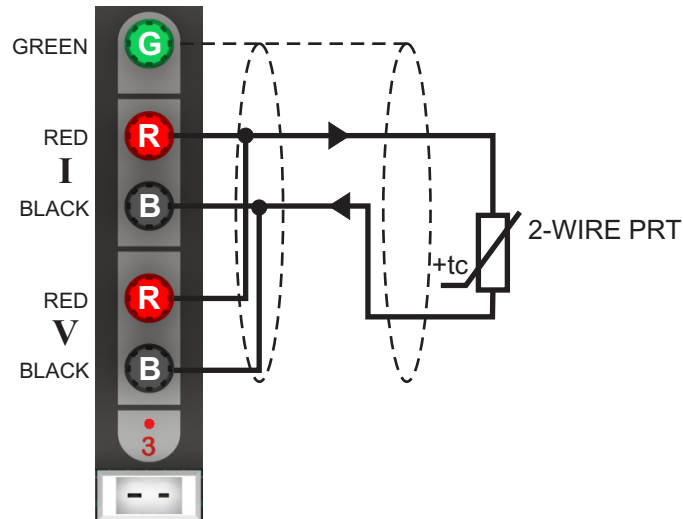

The connections to the PRT should be short (low resistance) in order to minimise the effect of lead resistance on the measurement. Alternatively, the connections can use remote sensing (using the 4-wire measurement capability of the milliK) to eliminate the effect of lead resistance completely. In this arrangement, the current and voltage sense connections are kept separate and are only joined close to the PRT:

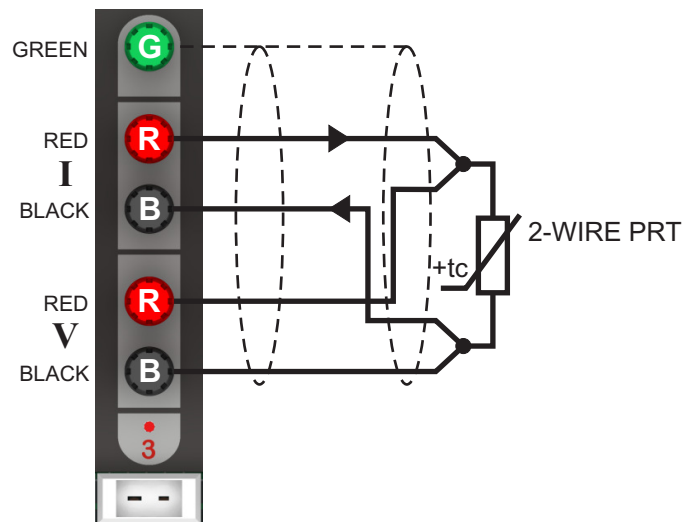

The top (green) terminal should be connected to the screen of the PRT's lead (where present) to minimise electrical noise picked up by the wires.

### ***3.5 Connecting Thermocouples***

Connect thermocouples to your millisKanner by using miniature thermocouple plugs that plug into the sockets below the binding posts for that channel. Copper miniature thermocouple plugs should be used if you intend to use an ice point reference or external reference junction compensation. If you intend to use internal reference junction compensation, fit a plug of the same type as the thermocouple. As with all thermocouple systems, the most accurate thermocouple measurements are made with an ice point and the least accurate measurements are made with the internal reference junction compensation.

If the thermocouple is provided with a screen (not common), it should be connected to the top (green) binding post to minimise electrical noise picked up by the wires.

#### **3.5.1 Connecting Thermocouples (using an ice point)**

To use a thermocouple with an ice point (reference junction immersed in an ice point), fit a copper miniature thermocouple connector to the thermocouple and connect this to the socket below the binding posts. In the 'Settings' screen, set the Reference Junction to "0°C":



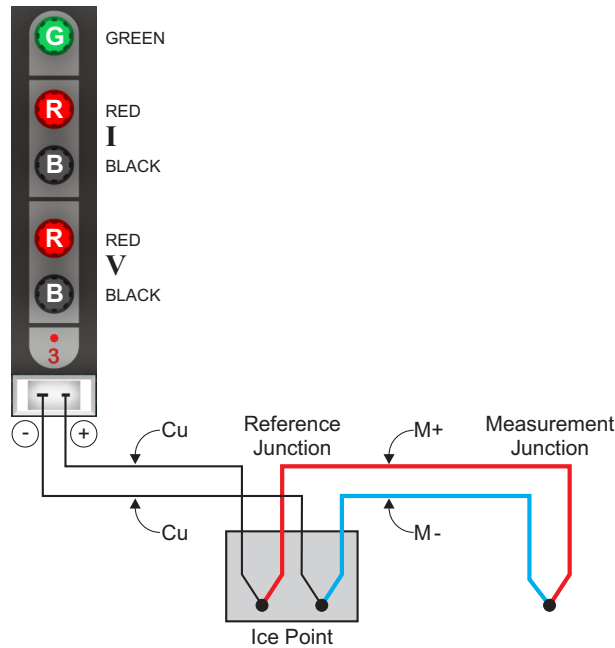

### 3.5.2 Connecting Thermocouples (using external compensation)

To use a thermocouple with external reference junction compensation (temperature of reference junction measured using another channel), fit a copper thermocouple connector to the thermocouple and connect this to the socket below the binding posts. Another temperature sensor (PRT or thermistor) must be used to measure the reference junction temperature (ensure that it is isothermal with the reference junction). Connect this sensor to another channel (on the milliK or a millisKanner) and configure it with a conversion to temperature units. If you do not first configure the channel so that it can measure temperature, it cannot be used as the reference junction sensor. You cannot use another thermocouple as the reference junction sensor as this could create circular dependencies (also thermocouples are generally not sufficiently accurate). In the 'Settings' screen for the thermocouple channel, set the 'Reference Junction' to "External" and select the appropriate channel for the reference junction temperature sensor:

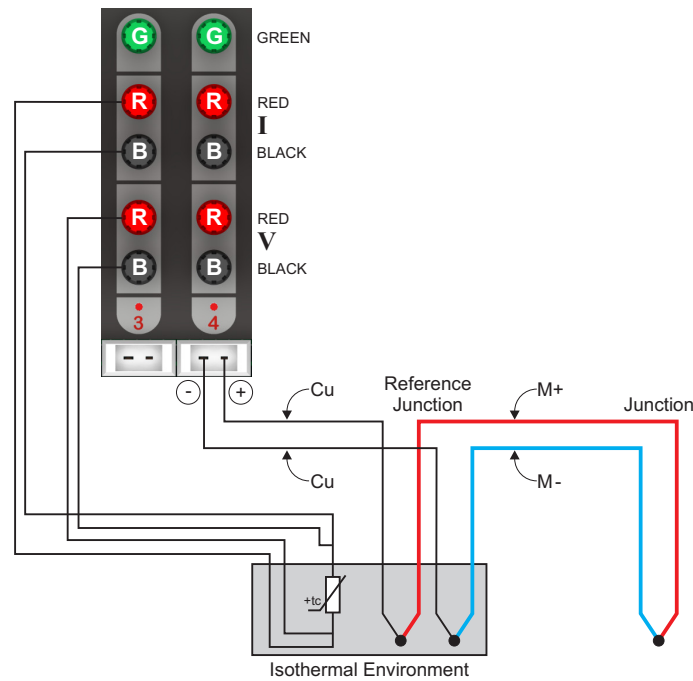

This technique is less accurate than using an ice-point due to the additional uncertainties associated with the PRT or thermistor used to monitor the reference junction and any temperature gradients between the temperature of the PRT/thermistor and the thermocouple’s reference junction.

### 3.5.3 Connecting Thermocouples (using internal compensation)

To use a thermocouple with internal reference junction compensation (reference junction formed within the millisKanner and its temperature measured using an internal sensor), fit a thermocouple connector of the same type as the thermocouple and connect this to the socket below the binding posts. In the ‘Settings’ screen for the thermocouple channel, set the ‘Reference Junction’ to “Internal”:

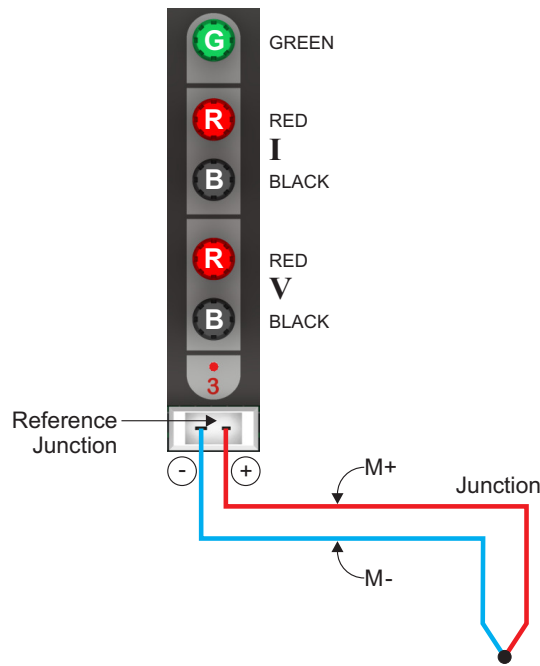

This technique is less accurate than using an ice-point or external compensation due to the additional uncertainties associated with the internal reference junction sensor and any temperature gradients between the reference junction formed within each miniature thermocouple connector and the temperature of the reference junction temperature sensor.

### 3.6 Connecting Thermistors

The millisKanner and milliK can be connected to thermistors using the same arrangement as for 2-wire PRTs (see section 3.4):

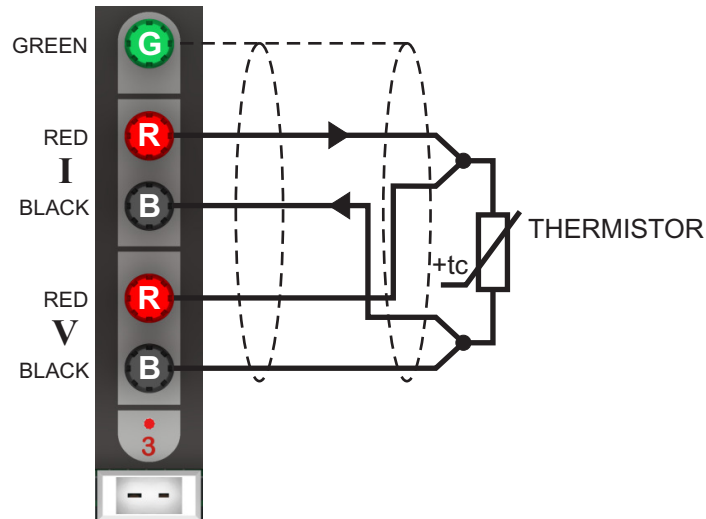

Because the resistance of thermistors used for temperature measurement is much higher than for PRTs, lead resistance is not normally a problem.

The top terminal should be connected to the screen of the thermistor's lead (where present) to minimise electrical noise picked up by the wires. The high resistance of thermistors makes them more prone to picking up electrical noise, it is therefore even more important to use a screened cable and connect this to the screen terminal on the millisKanner than when using PRTs.

## 4 Good Practice Guidelines

### *4.1 Looking After Your millisKanner*

Your millisKanner is a precision electronic instrument intended for indoor use in a laboratory, light industrial or office environment. Nonetheless, it has been designed to be as robust as practical and will provide many years of service, provided it is properly maintained.

The only part of the millisKanner that requires a routine calibration check is the internal reference junction temperature sensor. We recommend that you check this annually. You can check this yourself using the procedures given in this manual (see section 6.2), or we can provide a traceable calibration of your millisKanner at one of our approved calibration centres (contact Isothermal Technology or one of our appointed distributors for details). The millisKanner should require little maintenance between calibrations other than routine cleaning.

Clean your millisKanner, as required, using either a proprietary cleaner (such as those sold for cleaning PCs) or water and a little mild liquid soap on a lint-free cloth. Never use abrasive cleaners (such as 'cream' cleaners) on your millisKanner.

### *4.2 Making a Good Electrical Measurement*

Although the millisKanner and milliK are intended for use in temperature metrology, its base measurements are electrical (resistance or voltage). The limited sensitivity of PRTs and thermocouples means that in order to achieve uncertainties at the mK level, we need to make electrical measurements that rival those of a good electrical metrology laboratory. For example, for a 25 $\Omega$  SPRT a 5mK temperature uncertainty corresponds to

500 $\mu\Omega$  resistance uncertainty. With a 1 mA sense current, this corresponds to a voltage uncertainty of 0.5 $\mu$ V.

The millisKanner and milliK are optimised for electromagnetic compatibility (minimising emissions and maximising immunity). However, since the milliK is capable to measuring to such low signal levels it is worthwhile adopting good electrical measurement practices.

Here are a few guidelines:

- ‡ The most sensitive points are the inputs to the millisKanner or milliK (measuring to better than 0.5 $\mu$ V). Whilst the millisKanner and milliK will work satisfactorily with just a four-wire connection to the PRT or thermistor, it is better to use a screened cable and to connect the screen to the measurement ground terminal above the input terminals:

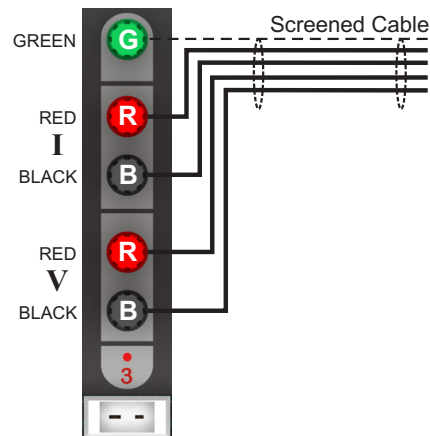

The screen should also be connected to the outer sheath of the PRT (if it is metal clad). The use of screened cables is more important when the milliK is used with thermistors, which have a higher resistance than PRTs or thermocouples.

- ‡ Keep the cables to the millisKanner and milliK input terminals away from other cables that might be sources of electrical noise (for example electrical supplies to furnaces).
- ‡ The insulation in high temperature furnaces (any that ‘glow’) begins to conduct at higher temperatures. This can cause high common-mode voltages on any

thermometer in the furnace. Whilst the milliK is designed to reject common-mode DC and AC signals (at both 50 and 60Hz), it is good practice to minimise them. It is common practice to use a metal equalising block in a furnace when performing comparison calibrations. This should be connected to the safety earth of the electrical supply (most furnaces designed for temperature metrology applications are fitted with a device to 'earth' the equalising block). Do not 'earth' the equalising block to the screen/measurement ground terminals on the front panel of your millisKanner or milliK as this is not connected to the safety earth of the electrical supply.

- ⌋ Provide a 'clean' electrical environment in your temperature laboratory. It may be useful to filter your electrical supply into the laboratory especially if other heavy electrical machinery is being used nearby on the same supply (the milliK has very good immunity to electrical noise conducted along the electrical supply, but other equipment in your laboratory may be more sensitive). It is worth avoiding the use of sources of electrical signals or noise in your laboratory. Examples include furnaces with triac controls (especially those that 'chop' the electrical supply part way through a cycle - better controllers switch only at the zero-crossing point to 'chop' only whole cycles), mobile phones (the millisKanner and milliK are not significantly affected by mobile phones, but other equipment may be more sensitive).

## 5 The millisKanner Technology

The millisKanner uses a number of new technologies and measurement techniques to achieve performance and ease of use that have not previously been available with similar multiplexers.

### *5.1 Minimising Thermal EMFs*

Thermal EMFs (EMFs generated when circuits comprising dissimilar metals are exposed to temperature gradients) are a potential source of error when working at this precision. These can be eliminated when measuring resistance thermometers by reversing the current and averaging the measurements (the offsets in the two measurements cancel each other out when the readings are averaged together). However, this technique cannot be used when measuring the voltage generated by thermocouples, so the thermal EMFs need to be eliminated at source. For this reason, we use tellurium–copper (gold plated) as the thermocouple connector contact material, since this combines good mechanical properties with extremely low thermal EMFs against the copper terminations of a thermocouple.

In order to eliminate thermal EMFs from the measurement system (already small), the input connections are reversed between the input and output terminals of the millisKanner. Measurements made with and without the reversal are then averaged together to eliminate the thermal EMFs generated in the connectors and cables used to connect the millisKanner to the milliK. The limitation is then the thermal EMFs generated by the devices used to implement this reversal.

The millisKanner duplicates the reversal system used by the milliK. It detects that it is making a measurement via a millisKanner, and then makes the reversal in the



millisKanner rather than the milliK. This means that the voltage measurement uncertainty is the same whether measurements are made directly on the milliK or via a millisKanner.

## ***5.2 Solid-State Switching***

One of the most common sources of failure in instruments of this complexity is the contacts in switches, relays, connectors and potentiometers. For this reason, the millisKanner was designed to have no switches, mechanical relays, internal connectors or potentiometers in order to ensure optimum reliability.

Conventional instruments of this type use mechanical relays for some or all of the signal routing. The millisKanner uses only solid-state switching. The thermal EMFs from these solid-state devices are significantly less than even the best mechanical relays. As a result, the millisKanner achieves voltage offsets significantly less than 2 $\mu$ V.

## 6 Calibration

The only part of the millisKanner that requires routine calibration is the reference junction temperature sensor. There is a single sensor for all the channels. The software in the milliK that is used to check and adjust its reference junction temperature sensor can also be used to check and adjust the calibration of the reference junction sensor in any attached millisKanner.

The millisKanner uses a high quality semiconductor sensor to measure the reference junction temperature in order to ensure good long-term stability. We recommend that you check its calibration annually using the procedures given below. Alternatively, we can provide a traceable calibration of your millisKanner at one of our approved calibration centres (contact Isothermal Technology or one of our appointed distributors for details).

### ***6.1 Before You Check the Calibration***

Any calibration should be performed in a temperature controlled environment between 19°C and 25°C. The millisKanner should be powered up and left to stabilise in the calibration environment for at least 2 hours before checking or adjusting calibration.

### ***6.2 Checking the Reference Junction Sensor***

Check the accuracy of the internal reference junction compensation (RJC) system by connecting a thermocouple to any of the millisKanner channels and measuring a known temperature using internal RJC mode. Any discrepancy between the measured and known temperature indicates an error in the RJC system (or the thermocouple used). You can use any thermocouple type for the measurement, but we recommend type J thermocouples as these have high sensitivity near room temperature and are readily available (the thermocouple needs to be fitted with a type J miniature thermocouple plug).

Connect the thermocouple to the milliKanner (channel 10 in the example below) and set the milliK to read °C for that channel with internal RJC by changing the parameters in the 'Settings' screen:

Channel	Channel 10
Status	Enabled
Thermometer	Default Thermocouple
Type	Thermocouple
Conversion	Type J
Range	±115mV
Units	°C
Reference Junction	Internal
Samples/Reading	1
Readings in Stats	100

Graph   Numeric   Settings   Instrument

Press the **Numeric** (F2) key, clear the statistics and wait for 100 measurements to be made (when the display shows "Mean of 100"). The mean value indicated by the milliK should be compared with the known temperature. Any discrepancy may be the result of errors in the RJC system or the thermocouple used. You might consider using an ice bath for the "known" temperature, and this is a reasonable choice. However, the error on a type J thermocouple, even at 20°C might be 5µV (or even higher), which corresponds to a temperature error of approximately 0.2°C. An alternative approach would be to use room temperature as the "known" temperature and to measure this with a calibrated PRT connected to the milliK. This approach has the advantage that the difference between room temperature and the reference junction in the milliKanner is likely to be very small (< 3°C) so any error resulting from imperfections in the thermocouple will also be small. You need to ensure that the thermocouple is at the same temperature as the PRT. You can create an adequate isothermal environment using a stainless steel vacuum flask filled with silicone oil (or another suitable liquid) and agitated with a small air pump of the type

designed to aerate fish tanks. Clip the thermocouple to the PRT such that the junction is near to the sensing element in the PRT (perhaps 1–2cm from the end) with nylon cable ties and immerse the assembly in the oil.





There is only one reference junction sensor for all the channels, so you can use any milliskanner channel for this check.

### 6.3 Adjusting the Reference Junction Sensor

You can adjust the calibration of the milliskanner using the RJC Sensor Calibration feature in the milliK to which it is attached. Before you can use this feature you must first attach a calibrated thermocouple to one of the channels and configure the channel for use with this thermometer (see milliK manual for details). If you measure the ambient temperature with a calibrated PRT and use this as the “known” temperature for the calibration, you can use a good quality, uncalibrated thermocouple since the difference between ambient temperature and the reference junction will be very small, so any error will be insignificant. If you use an uncalibrated thermocouple, make sure that you set the thermocouple ‘Conversion’ to the thermocouple type used:

Channel	Channel 10
Status	Enabled
Thermometer	Default Thermocouple
Type	Thermocouple
Conversion	Type J
Range	±115mV
Units	°C
Reference Junction	Internal
Samples/Reading	1
Readings in Stats	100

Graph
Numeric
Settings
Instrument

From the ‘Calibration Menu’ Window, use the   keys to select ‘RJ Sensor’ and then press the  key to proceed to the ‘RJ Sensor Calibration Adjustment’ screen. Use the  key

→ keys to select the relevant channel and then use the ↑↓ keys to select each parameter in turn and press the ↵ key to enter their values:

RJ Sensor Calibration	
Channel	10
1. Attach a calibrated thermocouple to the selected channel	
2. Enter details for standards used and then press OK to adjust calibration:	
Known Temperature	20.123000
Thermocouple Type	J - uncalibrated
Thermocouple S/N	not applicable
Additional Info.	wire error -4uV at 20C
Cancel	OK

Press the **OK** (F4) key to start the calibration adjustment. Once started, the calibration adjustment process cannot be aborted.

## 7 Updating Firmware

Update the firmware in your millisKanner by sending the *FIRMWARE:LOADER* command to an RS232 port (to set the millisKanner into programming mode) and then sending the new firmware (in Intel HEX format). The *FIRM:LOAD* command can be used to update the firmware or roll back to an earlier version. Once the *FIRM:LOAD* command has been invoked, the millisKanner will not return to normal operation until the firmware has been updated successfully.

Connect the millisKanner to your PC using a null-modem RS232 cable (see section 8.1). Use Hyperterminal (or another terminal emulator) to connect to your millisKanner. Hyperterminal is part of the standard Windows installation, usually located in the Accessories|Communications folder. If you have installed a minimum (laptop) or custom configuration (without this component) in your Windows operating system, you may need to install Hyperterminal from your original Windows media.

Start Hyperterminal to setup a new connection. Type in a name for the connection (such as millisKanner) and select an icon. In the next window, select the PC's COM port to which you have connected your millisKanner from the *Connect using* drop-down list and click OK. In the next window, enter the data format for the millisKanner's RS232 interface:

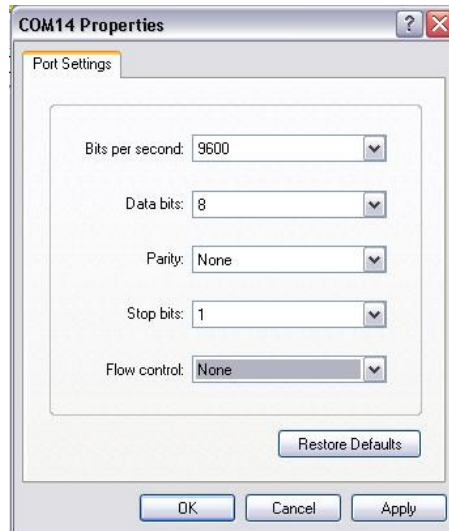

Click OK to open a Hyperterminal session with the millisKanner. Type *\*IDN?* into Hyperterminal (terminate the command by pressing the carriage return or Enter keys), the millisKanner should then respond with a string in the form:

Isothermal Technology, millisKanner,13-P525, 1.00

This confirms that you have successfully established an RS232 connection with your millisKanner. The last parameter reported is the current firmware version (in this case, 1.00) so you can ensure that you wish to change this for the version you are about to install.

Send *FIRM:LOAD 1234* (if password is still default value) to put the millisKanner into programming mode. The millisKanner will report "Switched to Bootloader mode", Now select "Send Text File..." from the "Transfer" drop-down menu. In the Window that opens, change "Files of type:" to "All files (\*.\*)" otherwise the required file will not be visible. Navigate to the new firmware file, which will have a filename similar to "millisKanner\_1\_00.hex" and then click 'Open'. Hyperterminal will then send the new firmware file to the millisKanner, which will show progress by returning decimal points:





## 8 RS232 Interface

The millisKanner is configured and controlled through its RS232 interface(s). It is equipped with two RS232 interfaces so that a number of millisKanners can be controlled by a single milliK precision thermometer (or other measuring instrument) by 'daisy-chaining' them together with RS232 null-modem cables. The millisKanner responds identically to data received on the two RS232 ports so they are completely interchangeable. Even in a system in which a number of millisKanners are daisy-chained together, the cables to the two RS232 ports may be reversed without any impact on the operation of the system.

### *8.1 Establishing an RS232 Connection*

The RS232 connectors are located on the rear of your millisKanner (see section 1.3). The connector is a 9-way (male) D-type configured as a standard DTE device:

<b>Pin</b>	<b>Name</b>	<b>Function</b>
1	CD	carrier detect (not connected)
2	RD	receive data
3	TD	transmit data
4	DTR	data terminal ready (connected to pin 6: DSR)
5	SG	signal ground
6	DSR	data set ready (connected to pin 4: DTR)
7	RTS	request to send (connected to pin 8: CTS)
8	CTS	clear to send (connected to pin 7: RTS)
9	-	not used (not connected)
Shell	FG	frame ground (screen)

Connect your millisKanner to the milliK, other millisKanners or a PC using a standard null-modem cable:

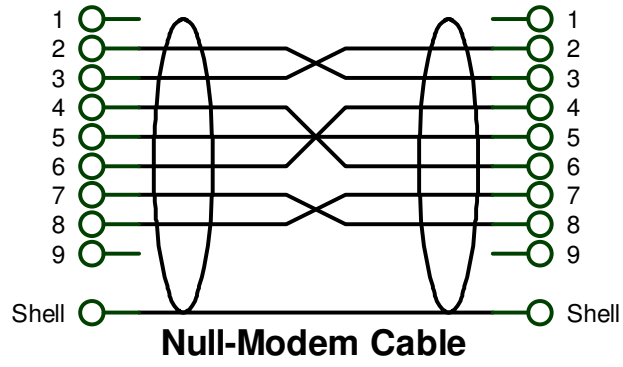

A screened RS232 cable is recommended for minimum emissions.

The format for the RS232 interface is as follows:

Baud Rate	9,600
Start Bits	1
Stop Bits	1
Parity Bit	none

The millisKanner has a 255-byte circular receive buffer. If the buffer becomes full and the data continues to be sent data this will be ignored (lost) until the millisKanner has had time to make space in the buffer by processing commands. The millisKanner returns a <CR> (carriage return) to indicate completion of all commands that changes its state. The milliK uses this feature to handshake with any connected millisKanners and so will never over-run the buffer.

Although the millisKanner is intended to be connected to and controlled by a milliK Precision Thermometer, you can control it from a PC using your own software or Hyperterminal (or another terminal emulator) via the RS232 connection. Hyperterminal is part of the standard Windows installation, usually located in the Accessories|Communications folder. If you have installed a minimum (laptop) or custom configuration (without this component) for your Windows operating system, you may need to install Hyperterminal from your original Windows media.

Start Hyperterminal to setup a new connection. Type in a name for the connection (such as millisKanner) and select an icon. In the next window, select the PC's COM port to which you have connected your millisKanner from the *Connect using* drop-down list and click OK. In the next window, enter the data format for the millisKanner's RS232 interface:

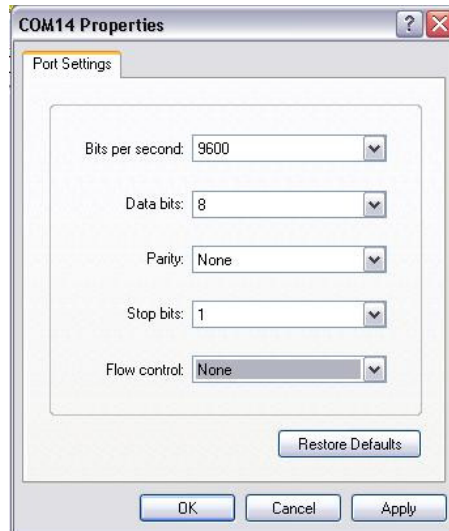

Click OK to open a Hyperterminal session with the millisKanner. Now save (using File|Save As) the Hyperterminal connection so that in future you only have to click on this icon to open an RS232 connection with your millisKanner.

Type *\*IDN?* into Hyperterminal (terminate the command by pressing the carriage return or Enter keys), the millisKanner should then respond with a string in the form:

Isothermal Technology, millisKanner,13-P525, 1.00

This confirms that you have successfully established an RS232 connection with your millisKanner.

## ***8.2 SCPI Command Set***

The command format and protocol used by the millisKanner is based on the SCPI (Standard Commands for Programmable Instruments) standard. This was developed to provide a consistent command language for all types of programmable instruments. The objective was to reduce the development time required by users of these instruments by providing a consistent programming environment through the use of defined messages, instrument responses and data formats. Further information on SCPI can be obtained from the SCPI Consortium (<http://www.scpiconsortium.org>).

## 8.2.1 SCPI Command Structure

Commands are arranged in a hierarchical tree, similar to directory trees used in personal computers. SCPI uses a defined notation to represent the command tree structure. Each node in the tree structure is a command keyword with keywords being separated by colons (:). To simplify the description of the SCPI commands, the notation represents levels in the tree using horizontal indentations with the root node being the leftmost column. For example, the millisKanner includes the following command structure:

```
REMOte
LOCal
*IDN?
*RST
[ROUte:]
    CLOSe
    CLOSe?
    OPEN[:ALL]
MILLiskanner
    :LIST?
    :INITialise
    :START?
    :CLOSe
    :OPEN
    :RJC
        :OFFset?
        : TEMPerature?
    :RST
MEAS
    :RJC?
CALibrate
    :RJC:OFFset
    :RJC:OFFset?
    :PASSword
    :UNLock
    :LOCK
FIRMware
```

:LOADer

A valid command is formed by following the tree structure from a root node until a node is reached with no further nodes below it, for example in the above command tree we may use:

MILLiskaner:RJC:TEMPerature?

Keywords can be shortened to the first four letters (or 3 if the last letter is a vowel). To indicate this, the notation uses upper-case to indicate required letters and lower-case to indicate optional letters (NB: all commands are case-insensitive). For example, valid forms of the above command include:

milliskanner:rjc:temperature?  
mill:rjc:temp?  
MILL:RJC:TEMP?  
Mill:Rjc:Temperature?

To shorten the commands, default (optional) keywords are enclosed in square brackets and may be omitted. For example, in the case of the command:

[ROUTE:]OPEN[:ALL]

Valid forms of this command include:

Route:Open:all  
ROUT:OPEN:ALL  
open

### 8.2.2 SCPI Numeric Suffices

In order to support multiple input channels, commands can include numeric suffices. These are represented by a hash (#) in the command notation, for example:

```
[ROUTE:]CLOSe#
```

In order to close input 3, the command used would be:

```
CLOS3
```

### 8.2.3 Parameters

If a command requires parameter(s), these follow the command and are separated from it by a space. If more than one parameter is required, each parameter is separated by a comma (,). For example, the command to change the password is:

```
CALibrate:PASSword <old password>,< password>,<password>
```

### 8.2.4 Controlling the millisKanner Using the RS232 Port

The millisKanner has two RS232 ports so that up to four millisKanners can be 'daisy-chained' onto the RS232 port of a milliK. The SCPI commands for the milliK and millisKanner have been designed to allow commands and data to be passed along the daisy-chain. Each device in the daisy-chain responds to commands that it recognises as being intended for it and passes any other commands or data on. During initialisation (after power is applied), the milliK assigns channel numbers to each millisKanner in the daisy chain (channels 10–17 for the first millisKanner, channel 20–27 for the second etc.).

The millisKanners are all controlled by the milliK during a measurement so it is not necessary for the user to control any of the millisKanners explicitly when making

measurements via the RS232 port. The millisKanner's unused RS232 port at the opposite end of the daisy chain to the milliK can be connected to a PC. The same commands used to make measurements with the milliK can be used to make measurement via the millisKanner channels. These are passed forward by each millisKanner until they reach the milliK. The milliK then issues the required commands to the millisKanners in order to select the specified channel and synchronises this with the measurements. Any responses from the milliK are passed back to the PC via the millisKanners.

For example, consider a milliK with two millisKanners attached. The PC is connected to the RS232 port on the second millisKanner, which will automatically be assigned channel numbers 20–27 by the milliK. To measure the resistance of a 4-wire PRT connected to the first input on the second millisKanner (channel 20) on the 125 $\Omega$  range at normal current (1 mA), the user can simply send the command:

*MEAS:RES20? 125,NORM,4*

This is identical to the command required to read directly from channel 1 of the milliK (see milliK manual) but with the channel number specified as 20 rather than 1.

### **8.2.5 Terminology – Inputs and Channels**

The terminals on a millisKanner are referred to as “Inputs” and are numbered 0 to 7 on each multiplexer. When connected to a milliK, these inputs are allocated a unique channel numbers so that they can be referenced/addressed by the milliK. The terms “Input” and “Channel” are used in this manual to distinguish between the physical input to the multiplexer and the number used to address the input channel.

The channel numbers are assigned by the milliK to each millisKanner in blocks of 8 aligned to the nearest decade value. The first millisKanner connected to the milliK is



assigned channel numbers 10 to 17. Subsequent millisKanners are assigned channel numbers 20–27 etc.

## 8.2.6 SCPI Commands

The millisKanner supports the following commands:

- REMOte
- LOCal
- \*IDN?
- \*RST
- [ROUTE:]
  - CLOSE#
  - CLOSE?
  - OPEN[:ALL]
- MILLiskanner
  - :LIST?
  - :INITialise
  - :START?
  - :CLOSE#
  - :OPEN#
  - :RJC
    - :OFFset#?
    - : TEMPerature#?
  - :RST
- MEAS
  - :RJC?
- CALibrate
  - :RJC:OFFset
  - :RJC:OFFset?
  - :PASSword
  - :UNLock
  - :LOCK
- FIRMware
  - :LOADer

A detailed description of each command follows:

### 8.2.6.1 Command: REMote

Format: REMote

Sets the millisKanner for remote (RS232) control only and disables local controls (left/right buttons). The millisKanner always starts in local mode.

Example: to prevent the user from controlling the millisKanner using the left/right buttons, send *REM*.

### 8.2.6.2 Command: LOCal

Format: LOCal

Re-enables local controls (left/right buttons). The millisKanner always starts in local mode (as if *LOC* had been sent).

Example: to re-enable the left/right buttons (after they have been disabled by sending *REM*), send *LOC*.

### 8.2.6.3 Command: \*IDN?

Format: \*IDN?

Reports information on the millisKanner in 4 comma separated fields:

- ⌋ manufacturer
- ⌋ model
- ⌋ serial number
- ⌋ firmware version

Example: for a millisKanner with serial number 13-P525 using firmware version 1.00, the millisKanner responds to *\*IDN?* with:

#### 8.2.6.4 Command: \*RST

Format: \*RST

Performs a reset (equivalent to a power-on reset) of the millisKanner.

#### 8.2.6.5 Command: [ROUTE:]CLOSe#

Format: [ROUTE:]CLOSe<input#> *{POSitive/NEGative}*

Selects (connects input to output) the specified input (on the millisKanner to which the RS232 connection is made). The polarity of the sense terminals is defined by the *{POSitive/NEGative}* parameter. The millisKanner returns a <CR> (carriage return) to acknowledge that the channel has been selected and is ready to use.

Example: to select the first millisKanner input with normal (positive) polarity, use:

*CLOSE0 POS*

#### 8.2.6.6 Command: [ROUTE:]CLOSe?

Format: [ROUTE:]CLOSe?

Reports the connection status (which channels are selected and their settings) on the millisKanner to which the RS232 connection is made.

Example: a milliKanner with channel 3 selected for normal polarity (positive) will respond to *CLOS?* with “3,positive”. If no inputs are selected, the response is “0,open”

#### 8.2.6.7 Command: [ROUTE:]OPEN[:ALL]

Format: [ROUTE:]OPEN[:ALL]

Deselects (disconnects) all inputs (on the milliskanner to which the RS232 connection is made).

Example: to deselect all inputs use: *OPEN*

### 8.2.6.8 Command: MILLiskanner:LIST?

Format: MILLiskanner:LIST?

This command is used by the milliK to 'discover' which milliskanners are connected in the 'daisy-chain'. It reports information on the milliskanner and also forwards the command to the next milliskanner in the daisy chain (on the alternate RS232 port) so that it will also respond.

Example: if there are two milliskanners (serial numbers 13-P543 and 13-P544, firmware 1.00) connected in the daisy chain with a milliK (serial number 13-P432, firmware 2.00) at the other end of the chain, the response to *MILL:LIST?* will be:

```
Isothermal Technology,milliskanner,13-P543,1.00  
Isothermal Technology,milliskanner,13-P544,1.00  
Isothermal Technology,milliK,13-P432,2.00
```

### 8.2.6.9 Command: MILLiskanner:INITialise

Format: MILLiskanner:INITialise *<start>*

This command is reserved for use by the milliK and should not be used directly. It is used to assign channel numbers to each milliskanner in the daisy-chain. It assigns channel number *<start>* to the first input and sends the same command with *<start>* incremented by 10 to the next milliskanner in the daisy-chain (on the alternate RS232 port).

Example: after discovering whether there are any milliskanners attached at power-up, the milliK will send the command *MILL:INIT 10* to start numbering input channels on the milliskanners from channel 10 upwards.

#### 8.2.6.10 Command: MILLiskanner:START?

Format: MILLiskanner:START?

Reports the channel number of the first input (on the milliskanner to which the RS232 connection is made).

Example: in a system with two milliskanners connected to a milliK, the response to the command *MILLI:START?* sent to the second (last) milliskanner in the daisy-chain is "20".

#### 8.2.6.11 Command: MILLiskanner:CLOSe

Format: MILLiskanner:CLOSe<channel#> *{POSitive/NEGative}*

This command is reserved for use by the milliK and should not be used directly. It is used to select (connect input to output) the specified channel in the daisy-chain. All other channels are automatically deselected. The polarity of the sense terminals is defined by the *{POSitive/NEGative}* parameter. The milliskanner returns a <CR> (carriage return) to acknowledge that the channel has been selected and is ready to use.

Example: to select channel 17 with normal (positive) polarity, use: *MILL:CLOS17 POS*

#### 8.2.6.12 Command: MILLiskanner:OPEN

Format: MILLiskanner:OPEN<channel#>

This command is reserved for use by the milliK and should not be used directly. It is used to deselect (disconnect) the specified channel in the daisy-chain.

Example: to deselect channel 17, use: *MICR:OPEN17*

### 8.2.6.13 Command: MILLiskanner:RJC:OFFSet#?

Format: MILLiskanner:RJC:OFFSet<channel#>?

Reports the calibrated RJC sensor offset (in °C) for the specified channel.

Example: a milliskanner (assigned channel numbers 20–29) with an RJC sensor offset of 0.123°C will respond to *MILL:RJC:OFFS25?* with “0.123”.

### 8.2.6.14 Command: MILLiskanner:RJC:TEMPerature#?

Format: MILLiskanner:RJC:TEMPerature<channel#>?

Reports the temperature of the reference junction (in °C) for the specified channel.

Example: a milliskanner (assigned channel numbers 20–29) with a reference junction temperature of 20.123°C will respond to *MILL:RJC:TEMP25?* with “20.123”.

### 8.2.6.15 Command: MILLiskanner:RST

Format: Command: MILLiskanner:RST

This command is reserved for use by the milliK and should not be used directly. It is used to reset all the milliskanners in the daisy-chain by performing a reset (equivalent to a power-on reset) and passing the command to the next milliskanner in the daisy-chain.

Example: on power-up a milliK will send the command *MILL:RST* to reset all the milliskanners connected to its RS232 port.

### 8.2.6.16 Command: MEASure:RJC?

Format: MEASure:RJC?

Reports the temperature of the reference junction (on the millisKanner to which the RS232 connection is made).

Example: a millisKanner with a reference junction temperature of 20.123°C will respond to *MEAS:RJC?* with “20.123”.

#### **8.2.6.17 Command: CALibrate:RJC:OFFSet**

Format: CALibrate:RJC:OFFSet

Sets the value of the offset applied to the RJC sensor (on the millisKanner to which the RS232 connection is made). The value is in °C and has a range of  $\pm 10^{\circ}\text{C}$ . This command will only work if the calibration has first been unlocked using the *CAL:UNL* command (see section 8.2.6.20).

Example: to set an offset that will be added to the RJC temperature sensor on the millisKanner to 0.321°C (password still set to default value) use: *CAL:UNL 1234* followed by *CAL:RJC:OFFS 0.321*

#### **8.2.6.18 Command: CALibrate:RJC:OFFSet?**

Format: CALibrate:RJC:OFFSet?

Reports the offset added to measurements made by the reference junction sensor (on the millisKanner to which the RS232 connection is made).

Example: a milliK that has been calibrated to have a 0.321°C offset added to reference junction sensor measurements will respond to *CAL:RJC:OFFS?* with “0.321”.

#### **8.2.6.19 Command: CALibrate:PASSword**

Format: CALibrate:PASSword *<old password>*, *<password>*, *<password>*

Changes the password used to lock (protect) the calibration of the millisKanner. This is initially set to “1234”, but should be changed before using the millisKanner for any critical or traceable measurement or calibration work. The new password must be at least 4 characters in length and must be typed in identically twice in order to effect the change.

Example: to change the password from 1234 to ABCD use: *CAL:PASS 1234,ABCD,ABCD*

### **8.2.6.20 Command: CALibrate:UNLock**

Format: CALibrate:UNLock *<password>*

Unlocks the millisKanner to allow calibration adjustment. The millisKanner always powers up in the locked state. Calibration can be re-locked by cycling the power or using *CAL:LOCK* (see section 8.2.6.21).

Example: to unlock (enable) the calibration adjustment on a millisKanner with the default password (“1234”), use: *CAL:UNL 1234*

### **8.2.6.21 Command: CALibrate:LOCK**

Format: Calibrate: LOCK

Locks the millisKanner to prevent calibration adjustment.

Example: to lock the calibration of a millisKanner after adjustment, use: *CAL:LOCK*

### **8.2.6.22 Command: FIRMWare:LOADer**

Format: FIRMWare: LOADer *<password>*

Puts the millisKanner into a special mode that allows the firmware to be updated by subsequently sending the new file in Intel HEX format (see section 7).



Example: to put the millisKanner (which still has the default password “1234”) into the mode that allows the firmware to be updated, use: *FIRM:LOAD 1234*

## 9 Specification

<b>Accuracy</b>	Same as milliK used (the millisKanner contributes no additional measurement uncertainty – see section 5)
<b>Input Channels</b>	8
<b>Input/Output Connectors</b>	Binding Posts for: 4mm plugs, spades or bare wires Miniature thermocouple connectors (contact material: gold plated tellurium copper)
<b>Interfaces</b>	2 x RS232 (9,600 baud)
<b>Operating Conditions</b>	15–30°C / 50–85°F, 10–90% RH (for full specification) 0–40°C / 32–105°F, 0–95% RH (operational)
<b>Power</b>	90 – 264V (RMS), 47–63Hz (universal) 1.5W maximum
<b>Size</b>	255mm x 255mm x 80mm / 10.0” x 10.0” x 3.2” (W x D x H)
<b>Weight</b>	2.3kg / 5lb

## 10 Approvals

The millisKanner has been independently verified as complying with the regulatory requirements of the EU and FCC for electromagnetic compatibility and safety (EU only).

### *10.1 CE Declaration*



**European Community Electromagnetic Compatibility Directive (89/336)  
European Community Low Voltage Directive (93/68)**

The millisKanner multiplexer manufactured by Isothermal Technology Limited of Pine Grove, Southport, Merseyside, PR9 9AG, United Kingdom conforms to the requirements of the European Community Electromagnetic Compatibility Directive (89/336) and of the European Community Low Voltage Directive (93/68).

### *10.2 FCC Statement*

This equipment has been tested and found to comply with the limits for a Class A digital device, pursuant to part 15 of the FCC Rules. These limits are designed to provide reasonable protection against harmful interference when the equipment is operated in a commercial environment. This equipment generates and can radiate radio frequency energy and, if not installed and used in accordance with the instruction manual, may cause harmful interference to radio communications. Operation of this equipment in a residential area may cause harmful interference, in which case the user will be required to correct the interference at their own expense. Changes or modifications to this equipment not expressly approved by Isothermal Technology could degrade EMC performance and void the user's authority to operate the equipment.

### *10.3 Standards Applied*

The following standards have been applied in assessing compatibility with the requirements for CE marking and for FCC compliance:

Conducted Emissions	EN61326:2006 & CFR47:2012
Radiated Emissions	EN61326:2006 & CFR47:2012
Conducted Immunity	EN61326:2006
Radiated Immunity	EN61326:2006
Electrical Fast Transients	EN61326:2006
Electrostatic Discharge	EN61326:2006
Surge	EN61326:2006
Voltage Dips & Interruptions	EN61326:2006
Harmonic Currents	EN61000-3-2:2006
Flicker	EN61000-3-3:2008
Electrical Safety	EN61010-1:2010

## 11 Revision History

<b>Change Note</b>	<b>Date</b>	<b>Manual Issue</b>
Initial release	28/02/2013	1.00
CN13105	17/07/2013	1.01