

**Installation Manual**

P/N 3300991, Rev. C

November 2003

# Micro Motion<sup>®</sup> Series 3000

Installation Manual





# Micro Motion<sup>®</sup> Series 3000

## Installation Manual

For online technical support, refer to the EXPERT<sub>2</sub><sup>™</sup> tool at [www.expert2.com](http://www.expert2.com). To speak to a customer service representative, call the support center nearest you:

- In U.S.A., phone 1-800-522-MASS (1-800-522-6277)
- In Canada and Latin America, phone (303) 530-8400
- In Asia, phone (65) 6770-8155
- In the U.K., phone 0800 - 966 180 (toll-free)
- Outside the U.K., phone +31 (0) 318 495 670



# Contents

<b>1</b>	<b>Before You Begin . . . . .</b>	<b>1</b>
1.1	About this manual . . . . .	1
1.1	Safety . . . . .	1
1.2	European installations . . . . .	2
1.2	Symbols . . . . .	2
<b>2</b>	<b>Installing the Model 3300 or 3500 in a Panel . . . . .</b>	<b>3</b>
2.1	About this chapter . . . . .	3
2.2	Hazardous area installations . . . . .	3
2.3	Procedure for mounting in a panel . . . . .	3
<b>3</b>	<b>Installing the Model 3300 or 3500 in a Subrack . . . . .</b>	<b>15</b>
3.1	About this chapter . . . . .	15
3.2	Hazardous area installations . . . . .	15
3.3	Procedure for mounting in subrack . . . . .	15
<b>4</b>	<b>Installing the Model 3350 or 3700 . . . . .</b>	<b>23</b>
4.1	About this chapter . . . . .	23
4.2	Hazardous area classifications . . . . .	23
4.3	Procedure for field mounting . . . . .	23
<b>5</b>	<b>Connecting the Transmitter to a Sensor . . . . .</b>	<b>33</b>
5.1	About this chapter . . . . .	33
5.2	Cable types . . . . .	34
5.3	Cable and conduit preparation . . . . .	34
5.4	Wiring connections to sensor . . . . .	37
5.5	Wiring connections to transmitter . . . . .	37
<b>6</b>	<b>Installing Relays . . . . .</b>	<b>43</b>
6.1	About this chapter . . . . .	43
6.2	Specifications for user-supplied relays . . . . .	43
6.3	Hazardous area installations . . . . .	43
6.4	Replacing relays . . . . .	44
6.5	Software configuration . . . . .	44
6.6	Installing factory-supplied relays . . . . .	45
6.7	Installing user-supplied relays . . . . .	50
6.8	Discrete output configuration . . . . .	53

<b>7</b>	<b>Printer Setup</b> . . . . .	<b>55</b>
7.1	About this chapter . . . . .	55
<b>8</b>	<b>Startup</b> . . . . .	<b>61</b>
8.1	Startup and display test . . . . .	61
8.2	Configuration mode . . . . .	62
8.3	Sensor zero . . . . .	63
8.4	Fault outputs . . . . .	65
8.5	Alarm messages . . . . .	66
8.6	Repair and substitution of components . . . . .	66
8.7	Customer service . . . . .	66
	<b>Appendix A Specifications</b> . . . . .	<b>67</b>
	Model 3300 . . . . .	67
	Model 3350 . . . . .	71
	Model 3500 . . . . .	75
	Model 3700 . . . . .	79
	Model 3100 accessory . . . . .	83
	<b>Appendix B Optional Housing Dimensions</b> . . . . .	<b>85</b>
	<b>Appendix C Labels</b> . . . . .	<b>91</b>
	<b>Appendix D Return Policy</b> . . . . .	<b>93</b>
	<b>Index</b> . . . . .	<b>95</b>

# 1

## Before You Begin

### 1.1 About this manual

This instruction manual explains how to install the Micro Motion® Series 3000 Applications Platform.

#### Chapters

- **Chapter 2** explains how to mount the Model 3300 application peripheral or Model 3500 transmitter in a panel.
- **Chapter 3** explains how to mount the Model 3300 application peripheral or Model 3500 transmitter in a 19-inch (486,2 mm) subrack.
- **Chapter 4** explains how to mount the Model 3350 application peripheral or Model 3700 transmitter.
- **Chapter 5** explains how to connect the Model 3500 or 3700 transmitter to a Micro Motion® flow and density sensor.
- **Chapter 6** explains how to connect internally or externally powered relays to the discrete outputs.
- **Chapter 7** explains how to set up the applications platform to send a ticket to a printer.
- **Chapter 8** explains startup procedures.

#### Appendixes

- **Appendix A** lists specifications.
- **Appendix B** provides dimensions for NEMA housing options.
- **Appendix C** shows labels on the applications platform.
- **Appendix D** is the return goods policy.

### 1.1 Safety

Safety messages are provided throughout this manual to protect personnel and equipment. Read each safety message carefully before proceeding to the next step.

#### WARNING

**Improper installation in a hazardous area can cause an explosion.**

For information about hazardous applications, refer to Micro Motion ATEX, UL, or CSA installation instructions, shipped with the applications platform or available from the Micro Motion web site.

#### CAUTION

**Improper installation could cause measurement error or flowmeter failure.**

Follow all instructions to ensure applications platform will operate correctly.


## 1.2 European installations


This Micro Motion product complies with all applicable European directives when properly installed in accordance with the instructions in this manual. Refer to the EC declaration of conformity for directives that apply to this product.


The EC declaration of conformity, with all applicable European directives, and the complete *ATEX Installation Drawings and Instructions* are available on the internet at [www.micromotion.com/atex](http://www.micromotion.com/atex) or through your local Micro Motion support center.

## 1.2 Symbols


Below is a list of symbols pertaining to the manual and the product:

 Earth (ground) terminal


 Protective conductor terminal


 Frame or chassis terminal


 Direct current

 Alternating current

 Input

 Output

 Alert

 Warning, risk of electric shock

 Pulse wave

 Explosion hazard



# 2

## Installing the Model 3300 or 3500 in a Panel

### 2.1 About this chapter

This chapter explains how to mount the Model 3300 application peripheral or Model 3500 transmitter through a panel cutout.

### 2.2 Hazardous area installations

If you are installing the applications platform or the core processor in a hazardous area, ensure that your equipment and installation meet the hazardous area requirements. For more information about hazardous area classifications, see **Appendix A**. See **Figure 2-4** or **Figure 2-5** for location of the approvals tag on your applications platform.

If you are installing the Model 3300 application peripheral, see the following section.

#### Model 3300 installation

The Model 3300 may be installed outdoors, if it is installed in a panel providing a degree of ingress protection IP 65 according to EN 50529 (IEC 529). The Model 3300 is suitable for installation in Zone 2, complying with ATEX Directive (94/9/EC) for group II category 3G, according to CENELEC standard prEN 50021:1998 and marked as EEx nVL IIC T4.

### 2.3 Procedure for mounting in a panel

The procedure for mounting the applications platform in a panel includes the following steps:

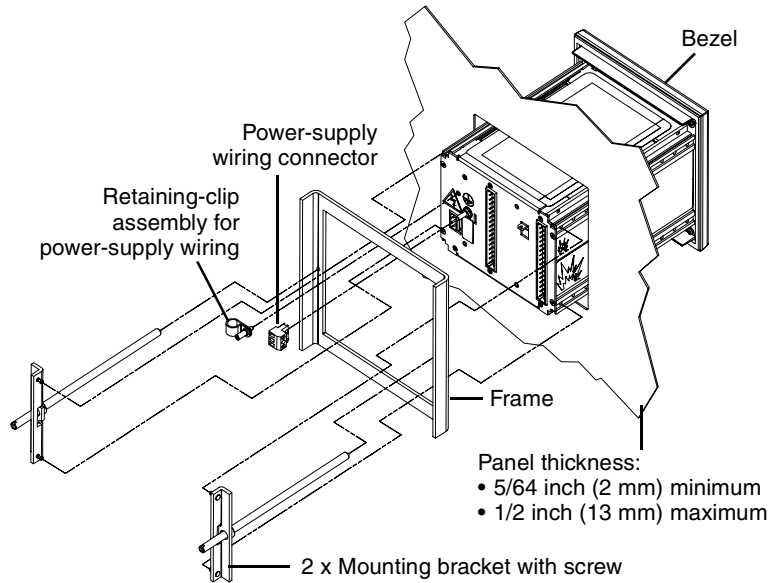
1. Choosing an appropriate location
2. Installing the applications platform in the panel
3. Installing power-supply wiring
4. Installing input and output wiring using the I/O cable or the screw-type wiring connector
5. If the applications platform is a Model 3500, connecting the Model 3500 to a sensor. To perform Step 5, see **Chapter 5**.

#### Installation kit for panel mounting

For mounting in a panel, the installation kit includes a bezel, frame, two mounting brackets with screws, a power-supply wiring connector, and a retaining clip assembly for power-supply wiring. See **Figure 2-1**.

- The applications platform fits through a 5 7/16-inch (138 mm) square cutout in a panel that is 5/64 inch (2 mm) to 1/2 inch (13 mm) thick.
- The panel cutout is the same size as the cutout for a Micro Motion DRT, FMS-3, DMS, NFC, or NOC peripheral device.
- The bezel provides a NEMA 4X (IP65) watertight seal between the panel cutout and the applications platform housing.
- The bezel is larger than the bezel on a Micro Motion DRT, FMS-3, DMS, NFC, or NOC peripheral device.

**Figure 2-1. Panel-mount installation kit**



### Step 1 Choose an appropriate location

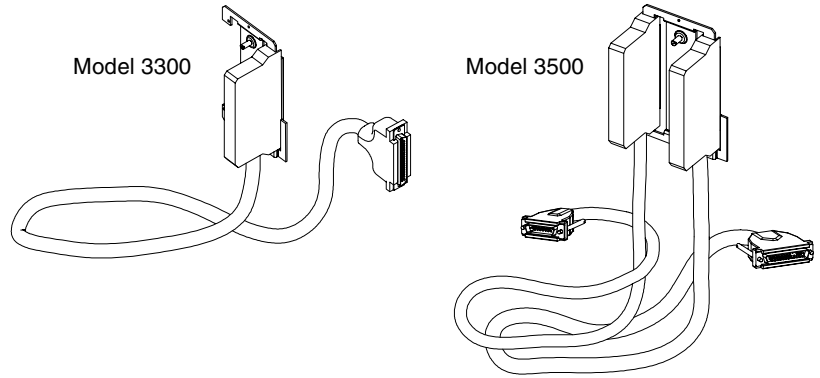
#### **⚠ WARNING**

**Improper installation in a hazardous area could cause an explosion.**

Install the applications platform in an area that is compatible with the rating on the approvals tag. See **Figure 2-4** and **Figure 2-5**.

- Install the applications platform where ambient temperature remains between  $-4$  and  $140^{\circ}\text{F}$  ( $-20$  and  $60^{\circ}\text{C}$ ).
- Maximum length of cable from a Micro Motion® sensor to the Model 3500 is 1000 feet (300 meters).
- Maximum length of wiring from the frequency input for a Micro Motion IFT9701 or RFT9739 transmitter is 500 feet (150 meters).
- If the applications platform has I/O cables, illustrated in **Figure 2-2**, see **Figure 2-4** for dimensions.
- If the applications platform has screw-type wiring connectors, illustrated in **Figure 2-3**, see **Figure 2-5** for dimensions.

**Figure 2-2. I/O cables**



**Figure 2-3. Screw-type wiring connectors**

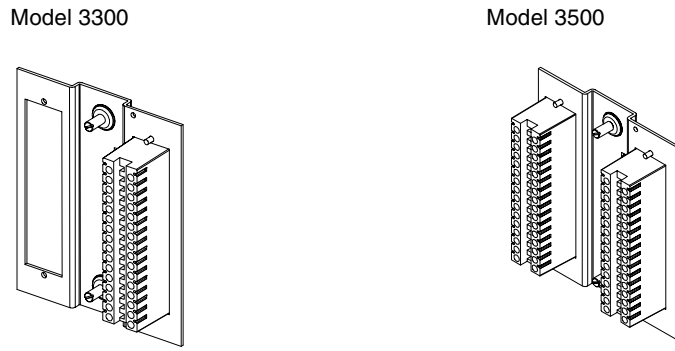


Figure 2-4. Panel-mount dimensions with I/O cables

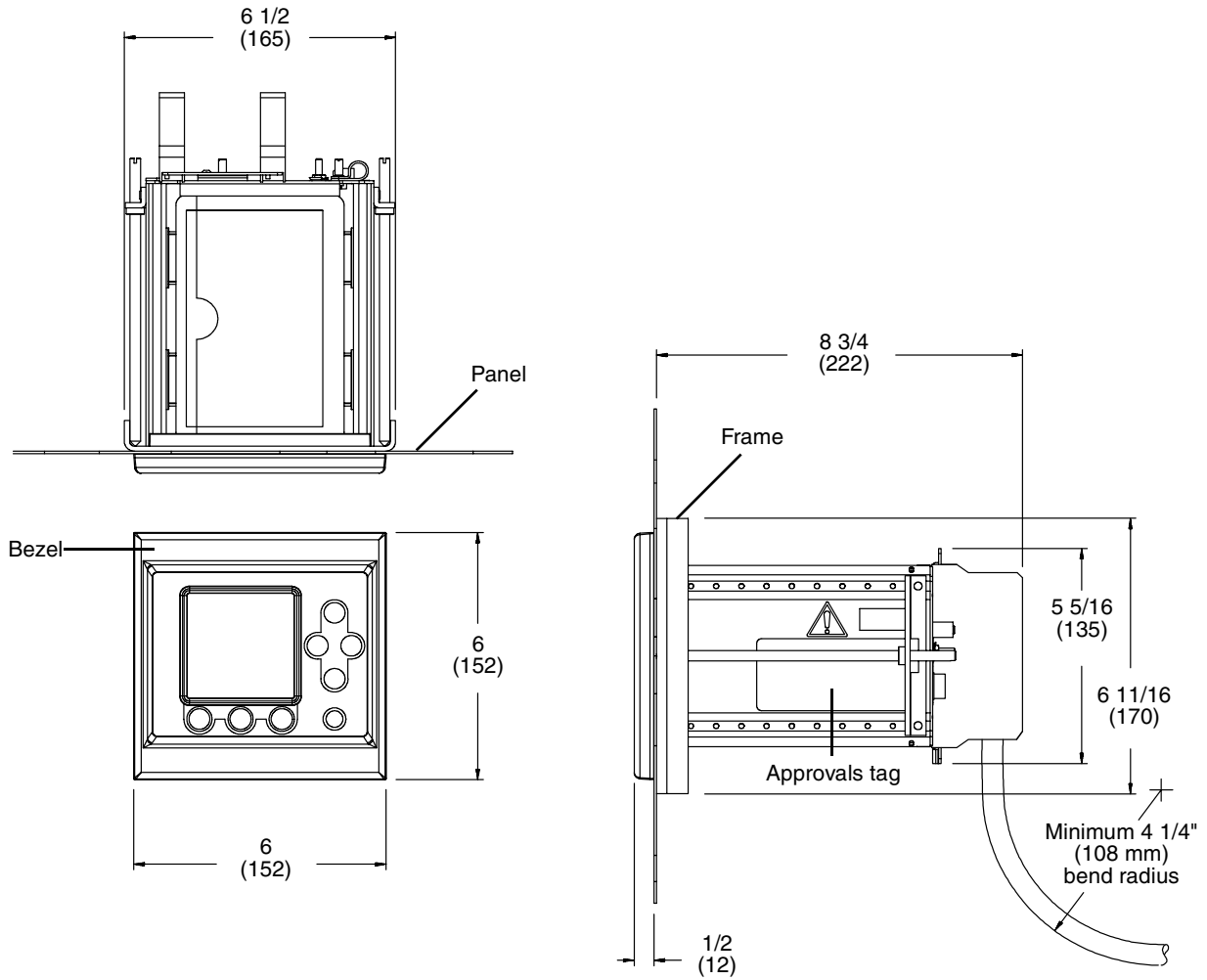
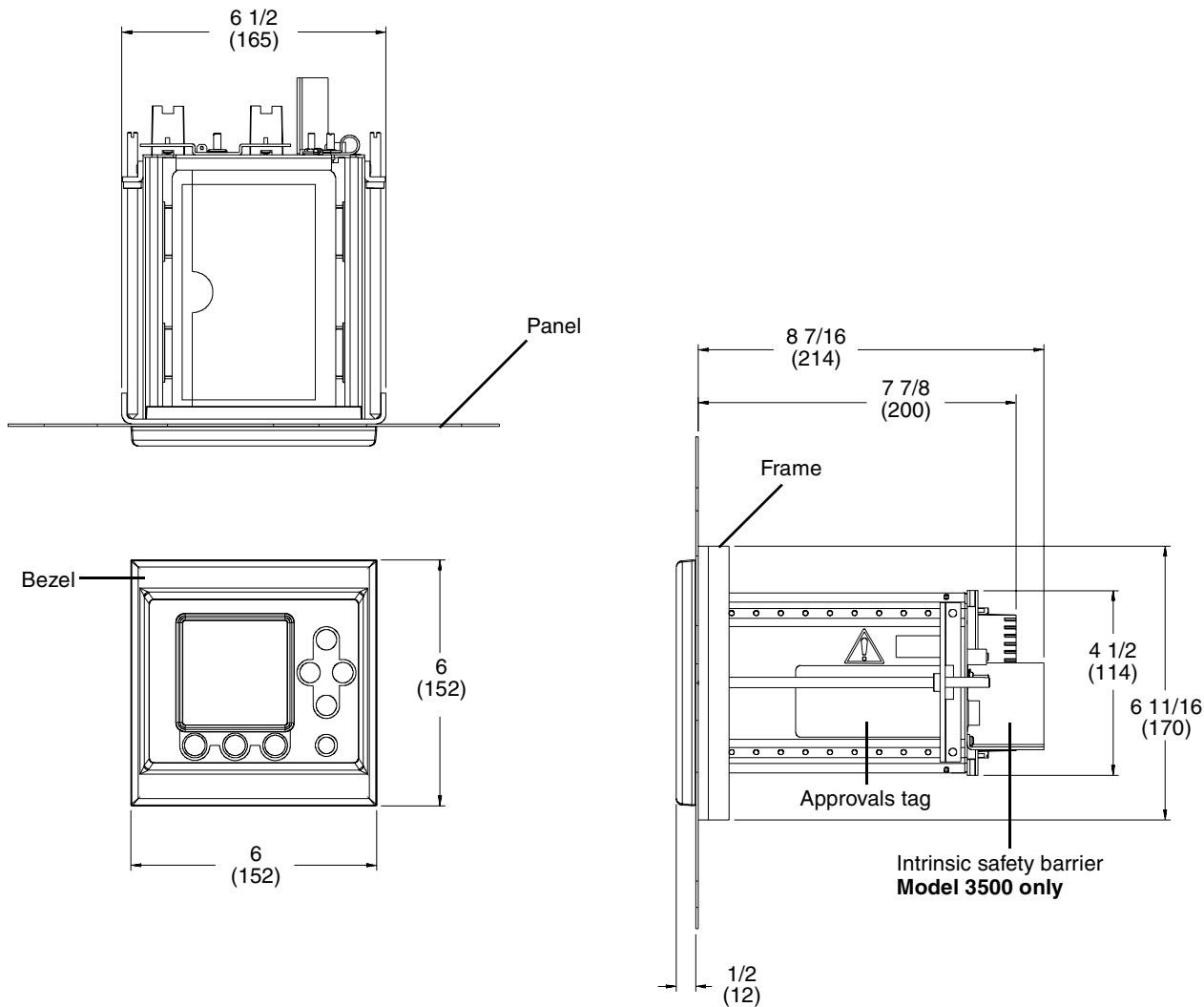


Figure 2-5. Panel-mount dimensions with screw-type connectors

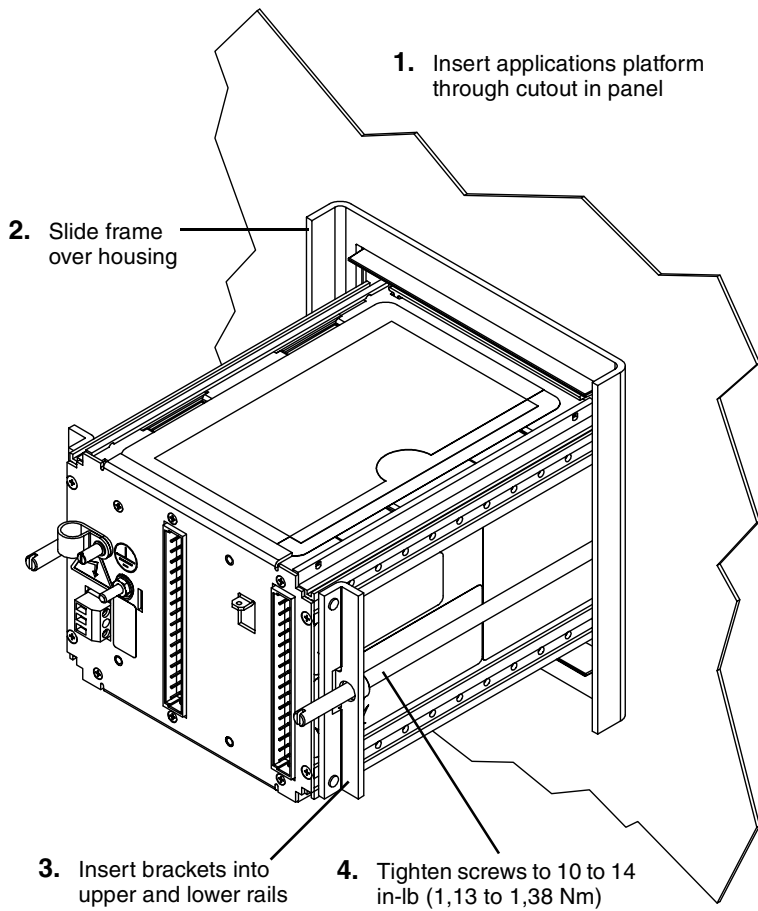


## Step 2 Install the applications platform in the panel

Refer to **Figure 2-6** and follow these steps:

- a. Insert the applications platform through the cutout.
- b. Slide the frame over the housing.
- c. Insert the posts on the brackets into the rails on the housing.
- d. Tighten the screws evenly to 10 to 14 inch-pounds (1,13 to 1,38 Nm) to ensure a watertight seal between the gasket and the panel.

**Figure 2-6. Steps for installation in panel**



### Step 3 Install power-supply wiring

#### CAUTION

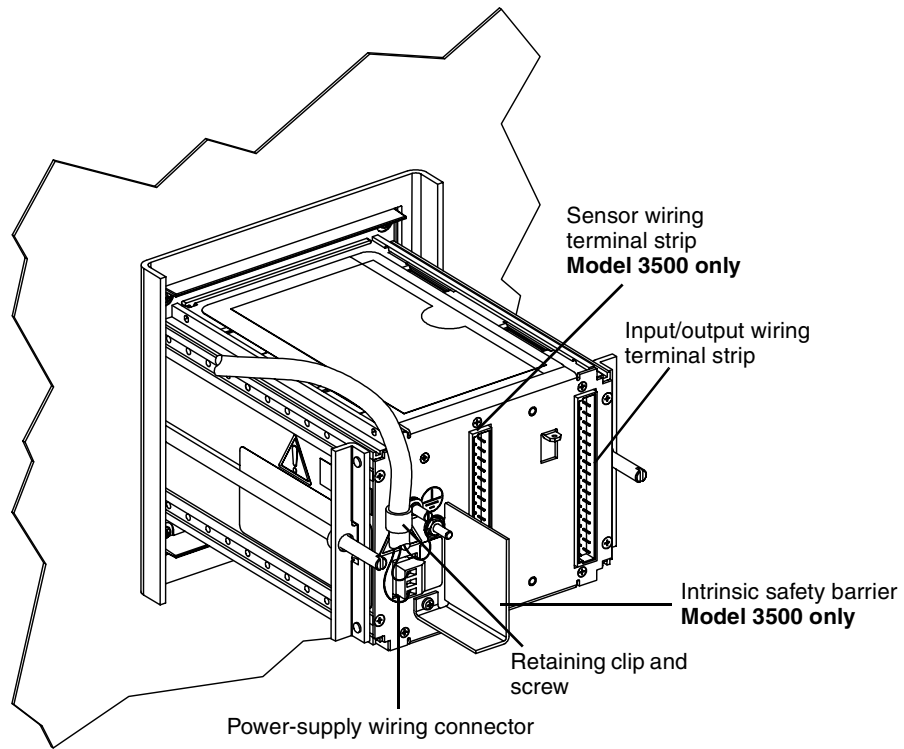
**Improper wiring installation can cause device failure or measurement error.**

- To avoid device failure or measurement error, do not install power-supply wiring in the same cable tray or conduit as input/output wiring.
- Shut off power supply before installing the applications platform.
- Make sure power-supply voltage matches voltage that is indicated on power-supply wiring terminals. See **Figure 2-8**.

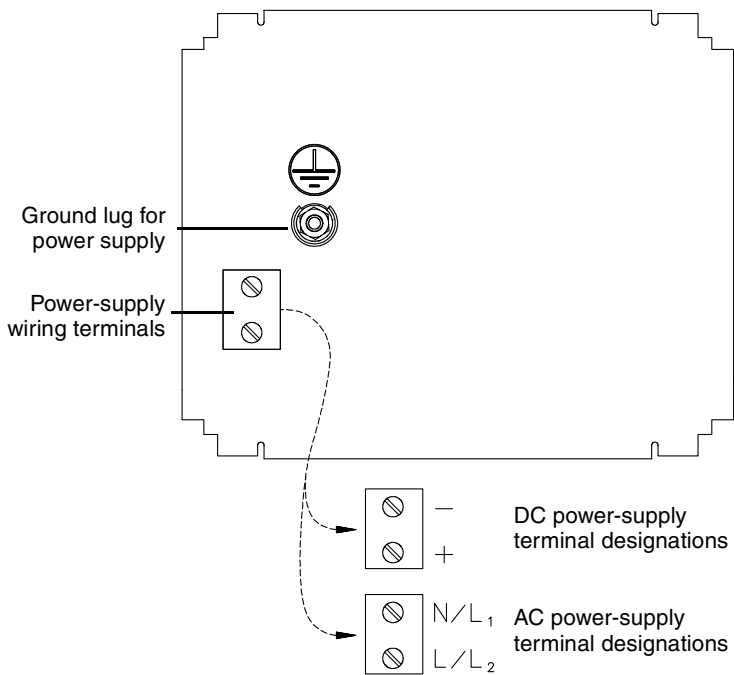
To install power-supply wiring, follow these steps:

- a. Plug in the power-supply wiring connector. See **Figure 2-7**.
- b. Connect 18 to 14 AWG (0,75 to 2,5 mm<sup>2</sup>) wiring to the power-supply wiring connector. See **Figure 2-8**.
  - Connect the ground wire to the ground lug for the power supply. Connect the power-supply ground directly to earth ground.
  - Keep all ground leads as short as possible.
  - Ground wiring must have less than 1 ohm impedance.
- c. Connect wires to the power-supply wiring terminals.
  - If the applications platform has a DC power supply, the upper terminal is negative (–), the lower terminal is positive (+).
  - If the applications platform has an AC power supply, the upper terminal is neutral (N or L1), the lower terminal is line (L or L2).
- d. Slide the retaining clip over the wiring, then tighten the screw to hold the clip in place. See **Figure 2-7**.
- e. A switch may be installed in the power-supply line. For compliance with low-voltage directive 73/23/EEC, a switch in close proximity to the applications platform is required.

**Figure 2-7. Wiring connectors and terminals on panel-mount platform**



**Figure 2-8. Power-supply wiring terminals on panel-mount platform**



- Connect power-supply ground directly to earth ground
- Keep all ground leads as short as possible
- Ground wiring must have less than 1 ohm impedance



## Step 4 Install input and output wiring

Installation of input and output wiring depends on the type of wiring connector that is installed.








### If the platform has screw-type connectors

- a. Plug the bracketed wiring connectors onto the terminal strips on the back panel of the applications platform.
- b. Tighten the captive screws to secure the bracket to the back panel.
- c. Connect input and output wiring to the appropriate terminals in the input/output wiring connector, which is the far right connector.
  - Install twisted-pair shielded wiring.
  - Wire size is 24 to 16 AWG (0,25 to 1,5 mm<sup>2</sup>).
  - Ground the shields at the field device.
  - Clip the shields at the end that connects to the applications platform.

A card that is inserted into the sleeve on the top panel lists input/output wiring terminal designations.

- See **Table 2-1** and the accompanying figure.
- Input and output assignments depend on the application. For more information, see the *Series 3000 Detailed Setup Manual*.

**Table 2-1. Input/output wiring terminals on screw-type connector**

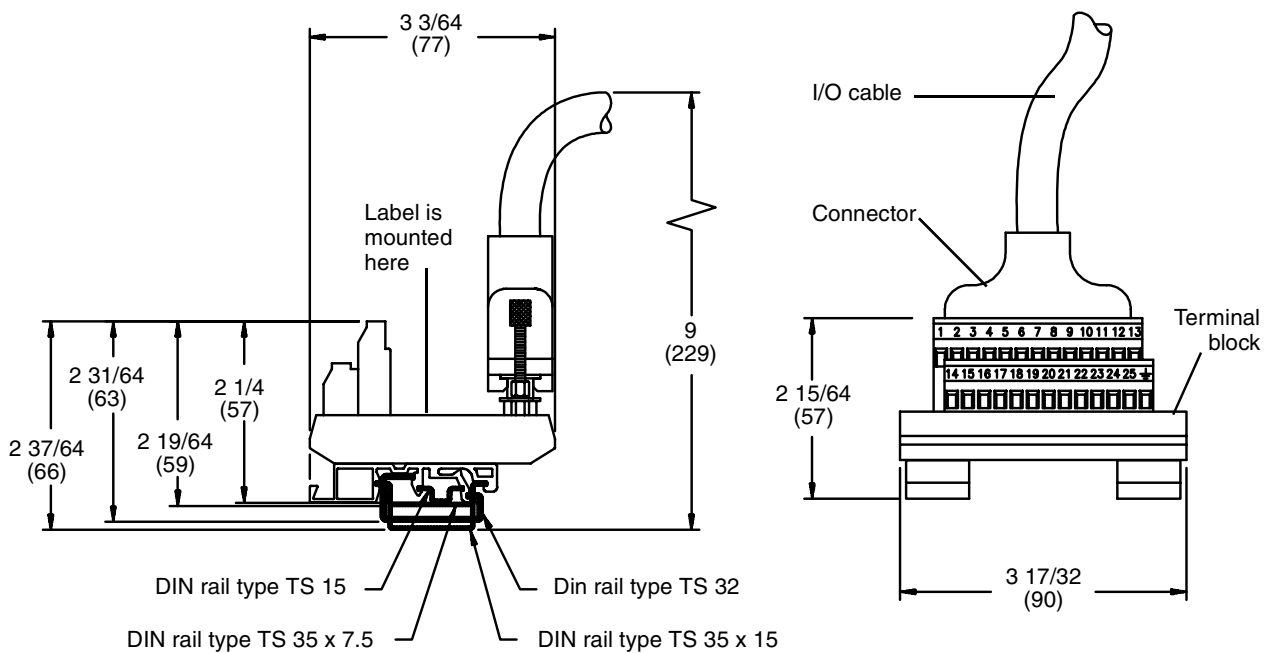
	c	a	
2	+	-	4-20 mA HART
4	+	-	4-20 mA
6	+	-	
8	+	-	Discrete 1 
10	+	-	Discrete 2 
12	+	-	
14	+	-	Discrete 1 
16	+	-	Discrete 2 
18	+	-	Discrete 3 
20			
22			
24			
26			● Comm 1 ● Comm 2
28			● Comm 3
30			
32	B	A	RS 485

Terminal number		Designation
c 2+	a 2-	Primary 4-20 mA output
c 4+	a 4-	Secondary 4-20 mA output
c 6+	a 6-	Frequency input
c 8+	a 8-	Discrete input 1
c 10+	a 10-	Discrete input 2
c 12+	a 12-	Frequency output
c 14+	a 14-	Discrete output 1
c 16+	a 16-	Discrete output 2
c 18+	a 18-	Discrete output 3
c 32 (B line)	a 32 (A line)	RS-485 output

**If the platform has I/O cables**

- a. Plug the bracketed wiring connectors onto the terminal strips on the back panel of the applications platform. Tighten the captive screws to secure the bracket to the back panel.
- b. Attach the supplied I/O terminal block to a DIN rail. The terminal block accommodates various rail types. See **Figure 2-9**.
- c. Plug the I/O cable connector onto the terminal block. Tighten the captive screws to secure the connector to the terminal block.
- d. Connect input and output wiring to the appropriate terminals on the terminal block.
  - Install twisted-pair shielded wiring.
  - Wire size is 24 to 16 AWG (0,25 to 1,5 mm<sup>2</sup>).
  - A label that is attached to the terminal block shows terminal designations for input/output wiring. See **Table 2-2**.
  - Input and output assignments depend on the application. For more information, see the *Series 3000 Detailed Setup Manual*.
- e. The terminal block ground is available for continuation of user cable shielding to I/O cable shielding.
  - The cable connector does not connect the I/O cable shielding to the chassis ground.
  - See **Figure 2-10**.

**Figure 2-9. Installing input/output terminal block on DIN rail**



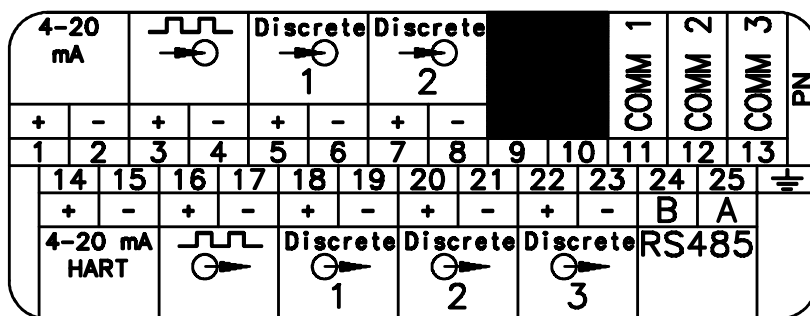
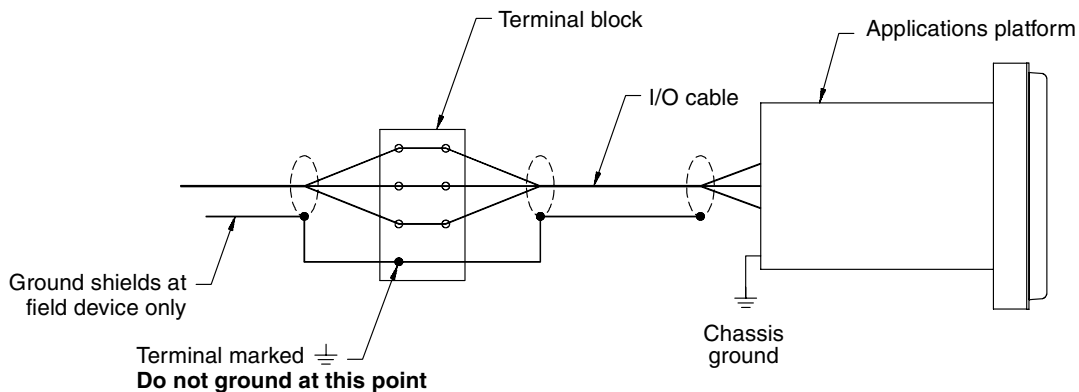


Table 2-2. Input/output wiring terminals on terminal block

Terminal number	Designation
1 +	2 - Secondary 4-20 mA output
14 +	15 - Primary 4-20 mA output
3 +	4 - Frequency input
5 +	6 - Discrete input 1
7 +	8 - Discrete input 2
16 +	17 - Frequency output
18 +	19 - Discrete output 1
20 +	21 - Discrete output 2
22 +	23 - Discrete output 3
24 (B line)	25 (A line) RS-485 output

Figure 2-10. Shield wiring for I/O cable to field device



### Step 5 Connect the Model 3500 to the sensor

To connect the Model 3500 transmitter to a Micro Motion® sensor, see **Chapter 5**.



# 3

## Installing the Model 3300 or 3500 in a Subrack

### 3.1 About this chapter

This chapter explains how to mount the Model 3300 application peripheral or Model 3500 transmitter in a 19-inch (486,2 mm) subrack.

### 3.2 Hazardous area installations

If you are installing the applications platform or the core processor in a hazardous area, ensure that your equipment and installation meet the hazardous area requirements. For more information about hazardous area classifications, see **Appendix A**. See **Figure 3-1** for location of the approvals tag on your applications platform. If you are installing the Model 3300 application peripheral, see below.

#### Model 3300 installation

The Model 3300 should be installed in a rack providing a degree of ingress protection IP 4X according to EN 50529 (IEC 529). The Model 3300 is suitable for installation in Zone 2, complying with ATEX Directive (94/9/EC) for group II category 3G, according to CENELEC standard prEN 50021:1998 and marked as EEx nVL IIC T4.

### 3.3 Procedure for mounting in subrack

The procedure for mounting the applications platform in a subrack includes the following steps:

1. Choosing an appropriate location for the installation
2. Installing guide rails and wiring connectors
3. Installing the applications platform in the subrack
4. Connecting power-supply wiring
5. Connecting input/output wiring
6. If the applications platform is a Model 3500, connecting the Model 3500 to a sensor. To perform Step 6, see **Chapter 5**.

#### Installation kit for rack mounting

##### Model 3300 installation kit

For mounting in a subrack, the Model 3300 installation kit includes the following parts (see **Figure 3-3**):

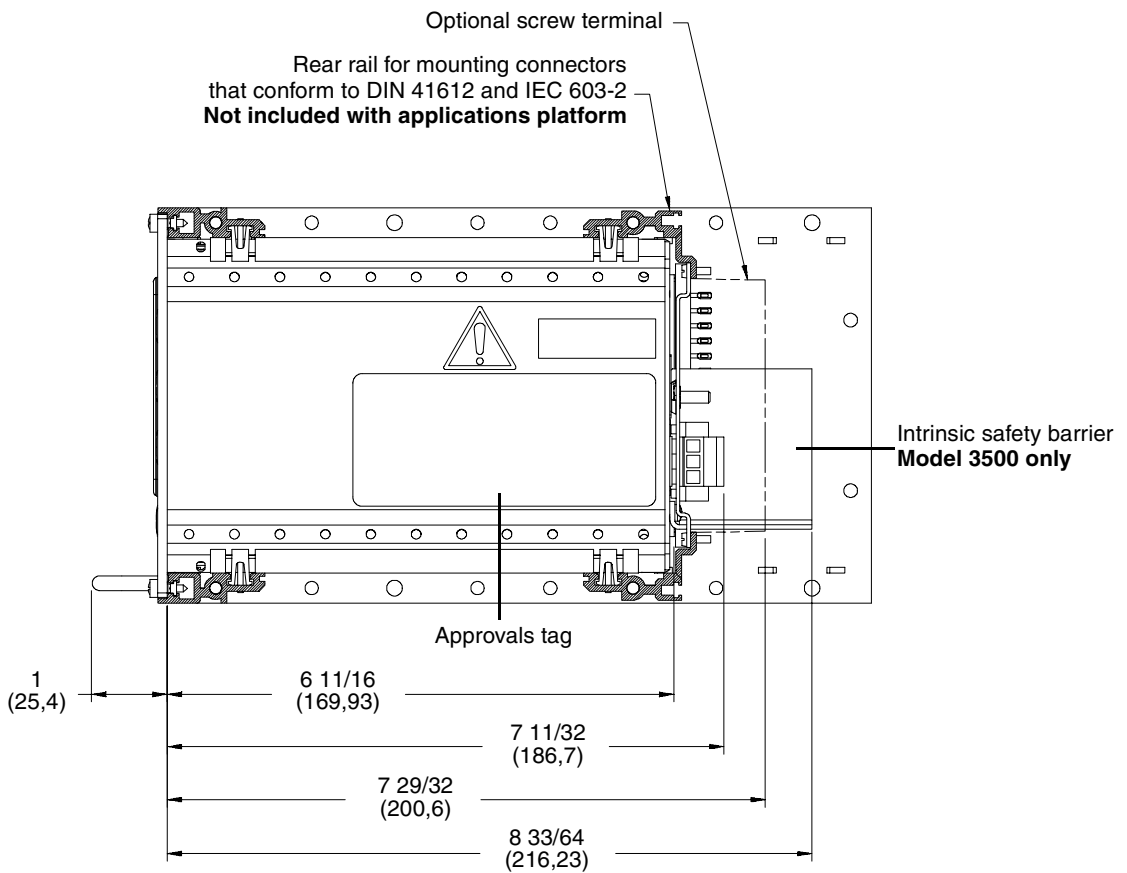
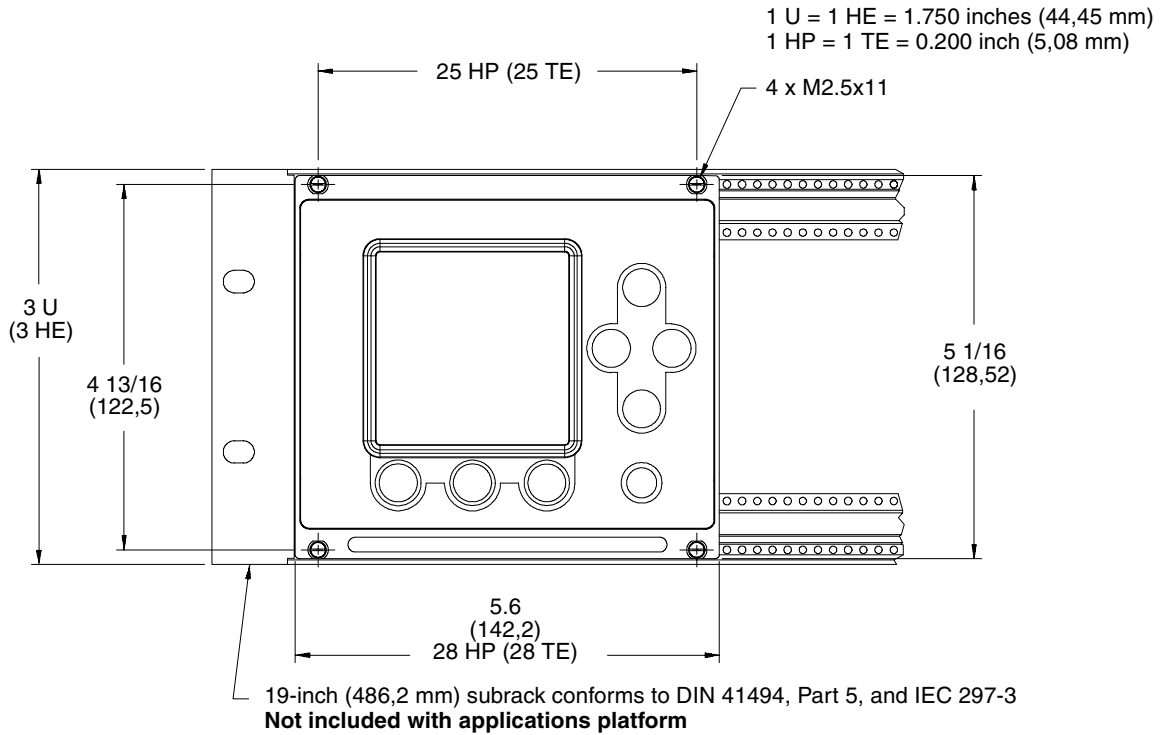
- One DIN standard 41612, Type D connector for input/output wiring, with solder tails or screw terminals
- One plug-in connector for power-supply wiring
- Four slotted cheese-head machine screws, size M2.5x8, for securing wiring connectors to the subrack

##### Model 3500 installation kit

For mounting in a subrack, the Model 3500 installation kit includes the following parts (see **Figure 3-3**):

- One DIN standard 41612, Type D connector for input/output wiring, with solder tails or screw terminals
- One DIN standard 41612, keyed Type D connector for sensor wiring, with solder tails or screw terminals
- One plug-in connector for power-supply wiring
- Six slotted cheese-head machine screws, size M2.5x8, for securing wiring connectors to the subrack

**Figure 3-1. Dimensions for mounting in subrack**



## Step 1 Locate and orient the applications platform

### **WARNING**

**Improper installation in a hazardous area could cause an explosion.**

Install the applications platform in an area that is compatible with the rating on the approvals tag. See **Figure 3-1**.

### Dimensions

The applications platform conforms to DIN standard 41494, Part 5 (IEC 297-3) for 19-inch (486,2 mm) racks.

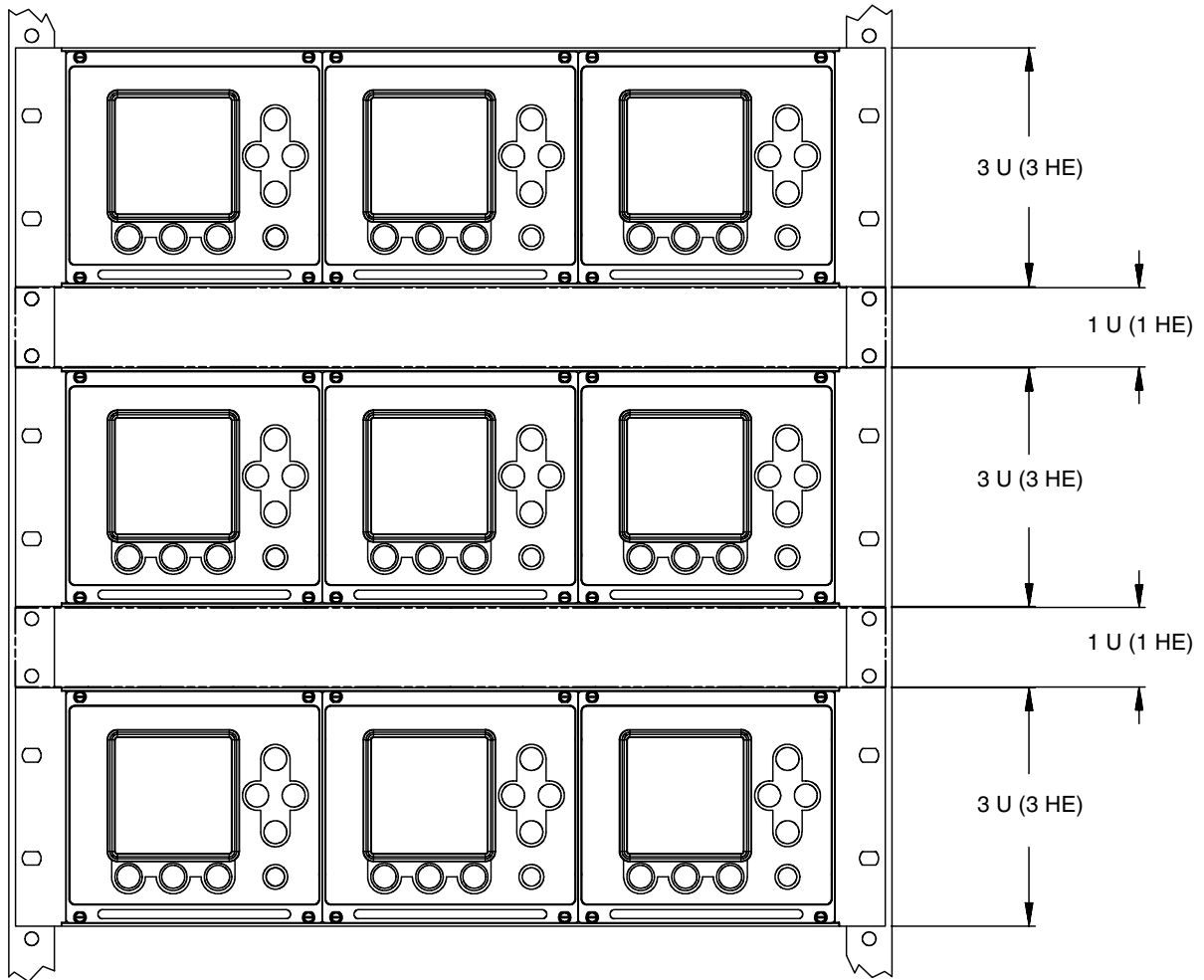
- Up to three applications platform enclosures fit into one subrack. See **Figure 3-2**.
- Height is 128 mm (3 U or 3 HE).
- Width is 142 mm (28 HP or 28 TE).
- Depth is 160 mm.

### Location guidelines

- Locate the applications platform where ambient temperature remains between  $-4$  and  $140^{\circ}\text{F}$  ( $-20$  and  $60^{\circ}\text{C}$ ).
- Maximum length of cable from a Micro Motion<sup>®</sup> sensor to the Model 3500 is 1000 feet (300 meters).
- Maximum length of wiring from the frequency input for a Micro Motion IFT9701 or RFT9739 transmitter is 500 feet (150 meters).
- To ensure proper ventilation if multiple application platforms are installed, provide at least 1 U (1 HE) of vertical space between subracks, as shown in **Figure 3-2**.

**Figure 3-2. Space requirements for proper ventilation**

1 U = 1 HE = 1.750 inches (44,45 mm)





## Step 2 Install guide rails and wiring connectors

### Guide rails

Positions of guide rails and wiring connectors are indicated in **Figure 3-3**. Centers of guide rails should be 27 HP (27 TE) apart, for example, at 1 HP (TE) and 28 HP (TE).

### Wiring connectors

- Use the supplied M2.5x8 screws to install the wiring connectors onto the back of the subrack.
- Install screws and connectors from the front of the subrack.

#### Model 3300 wiring connectors

The Model 3300 comes with a solder tail or screw-type connector for input/output wiring and a plug-in connector for power-supply wiring.

#### Model 3500 wiring connectors

The Model 3500 comes with a solder tail or screw-type connector for input/output wiring, a keyed solder tail or screw-type connector for sensor wiring, and a plug-in connector for power-supply wiring.

Using the centers of the guide rails as reference points and referring to **Figure 3-3**, install the wiring connectors in the following positions on the back of the subrack:

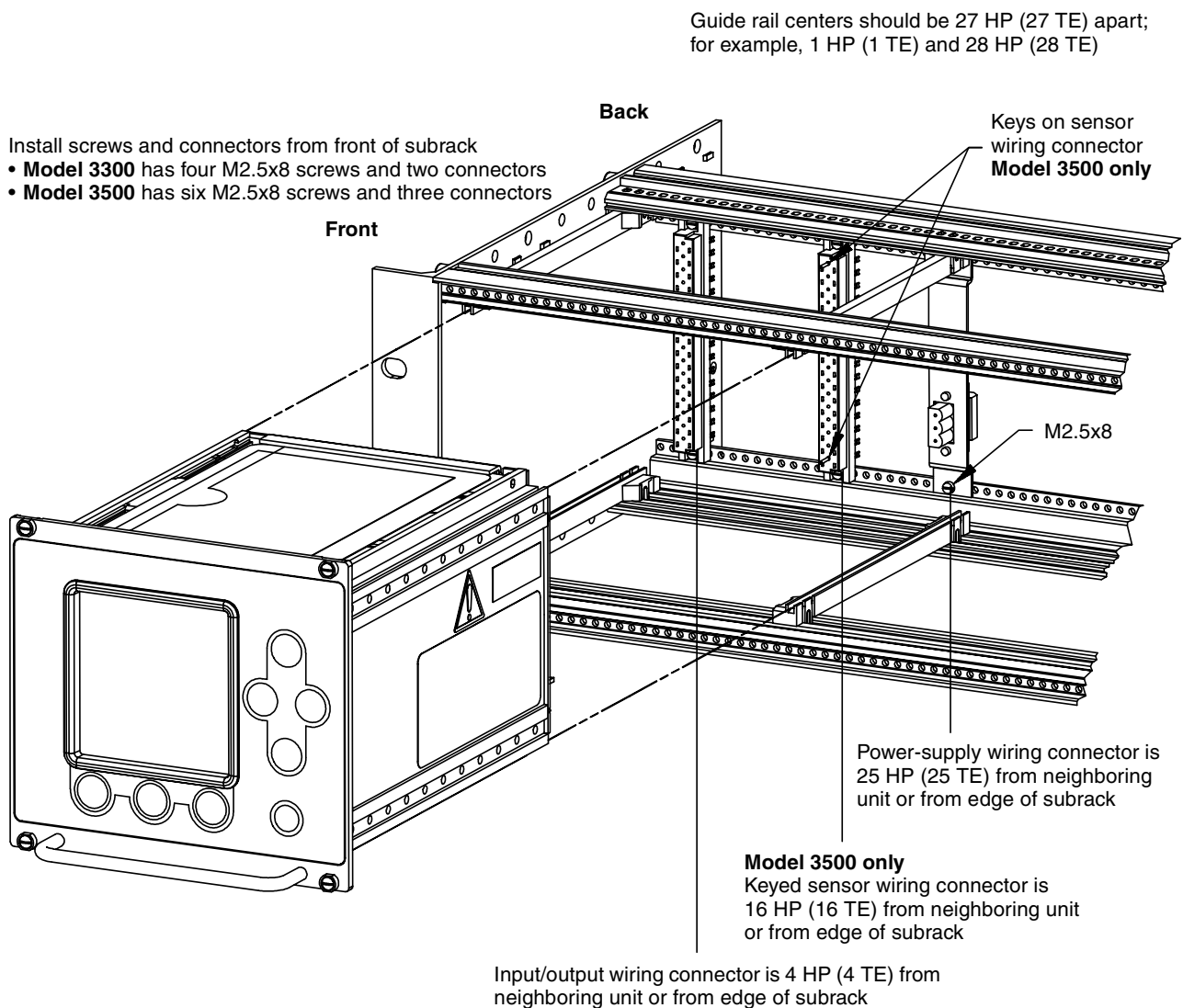
- Install the input/output wiring connector at 4 HP (4 TE) from the neighboring unit or from the edge of the subrack.
- If the applications platform is a Model 3500, install the keyed sensor wiring connector at 16 HP (16 TE) from the neighboring unit or from the edge of the subrack.
- Install the power-supply wiring connector at 25 HP (25 TE) from the neighboring unit or from the edge of the subrack.

### Step 3 Install the applications platform in the subrack

After installing guide rails and wiring connectors as instructed in **Step 2**, follow these steps to install the applications platform in the subrack:

- Align the applications platform with the guide rails.
- Slide the applications platform into the subrack. Make sure the pins on the back panel make contact with the wiring connectors.
- Tighten the supplied captive screws to secure the front panel of the applications platform to the guide rails.

**Figure 3-3. Positions of guide rails and wiring connectors**



## Step 4 Connect power-supply wiring

### ⚠ CAUTION

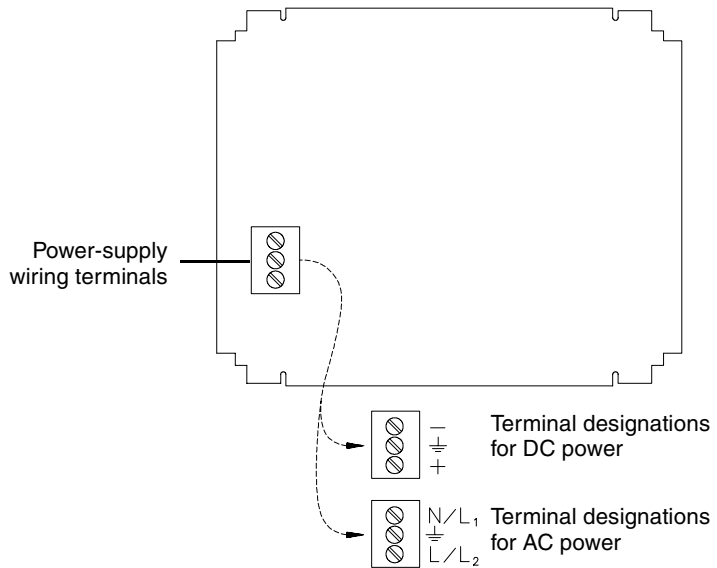
**Improper wiring installation can cause device failure or measurement error.**

- To avoid device failure or measurement error, do not install power-supply wiring in the same cable tray or conduit as input/output wiring.
- Shut off power supply before installing the applications platform.
- Make sure power-supply voltage matches voltage that is indicated on power-supply wiring terminals. See **Figure 3-4**.

Referring to **Figure 3-4**, follow these steps to connect 18 to 14 AWG (0,75 to 2,5 mm<sup>2</sup>) wiring to the power-supply wiring connector.

- Connect the ground wire to the middle terminal.
- Connect the power-supply ground directly to earth ground.
  - Keep all ground leads as short as possible.
  - Ground wiring must have less than 1 ohm impedance.
- Connect wires to the upper and lower terminals.
  - If the applications platform has a DC power supply, the upper terminal is negative (-), the lower terminal is positive (+).
  - If the applications platform has an AC power supply, the upper terminal is neutral (N or L1), the lower terminal is line (L or L2).
- A switch may be installed in the power-supply line. For compliance with low-voltage directive 73/23/EEC, a switch in close proximity to the subrack is required.

**Figure 3-4. Power-supply wiring terminals on rack-mount platform**



## Step 5 Connect input and output wiring








Connect input and output wiring to the appropriate terminals on the input/output wiring connector, which is the far right connector.

- Install twisted-pair shielded wiring, 24 to 16 AWG (0,25 to 1,5 mm<sup>2</sup>).
- Ground the shields at the field device.
- Clip the shields at the end that connects to the applications platform.

A card that is inserted into the sleeve on the top panel lists input/output wiring terminal designations.

- See **Table 3-1** and the accompanying figure.
- Input and output assignments depend on the application. For more information, see the *Series 3000 Detailed Setup Manual*.

**Table 3-1. Input/output wiring terminals on rack-mount platform**

	c	a	
2	+	-	4-20 mA HART
4	+	-	4-20 mA
6	+	-	
8	+	-	Discrete 1 
10	+	-	Discrete 2 
12	+	-	
14	+	-	Discrete 1 
16	+	-	Discrete 2 
18	+	-	Discrete 3 
20			
22			
24			
26			● Comm 1
			● Comm 2
28			● Comm 3
30			
32	B	A	RS 485

Terminal number		Designation
c 2+	a 2-	Primary 4-20 mA output
c 4+	a 4-	Secondary 4-20 mA output
c 6+	a 6-	Frequency input
c 8+	a 8-	Discrete input 1
c 10+	a 10-	Discrete input 2
c 12+	a 12-	Frequency output
c 14+	a 14-	Discrete output 1
c 16+	a 16-	Discrete output 2
c 18+	a 18-	Discrete output 3
c 32 (B line)	a 32 (A line)	RS-485 output

## Step 6 Connect the Model 3500 to the sensor

To connect the Model 3500 transmitter to a Micro Motion<sup>®</sup> sensor, see **Chapter 5**.

# 4

## Installing the Model 3350 or 3700

### 4.1 About this chapter

This chapter explains how to install the Model 3350 application peripheral or Model 3700 transmitter. The Model 3350 or 3700 can be installed on an instrument pole or a flat surface.

### 4.2 Hazardous area classifications

If you are installing the applications platform or the core processor in a hazardous area, ensure that your equipment and installation meet the hazardous area requirements. For more information about hazardous area classifications, see **Appendix A**. See **Figure 4-2** for location of the approvals tag on your applications platform.

**⚠ WARNING**

**Explosion Hazard.**

**Do not open wiring compartments when an explosive gas atmosphere is present.**

**Figure 4-4** identifies the compartments.

**⚠ WARNING**

**Using a dry cloth to clean the display cover can cause static discharge, which could result in an explosion in an explosive atmosphere.**

To prevent an explosion, use a clean, damp cloth to clean the display cover in an explosive atmosphere.

### 4.3 Procedure for field mounting

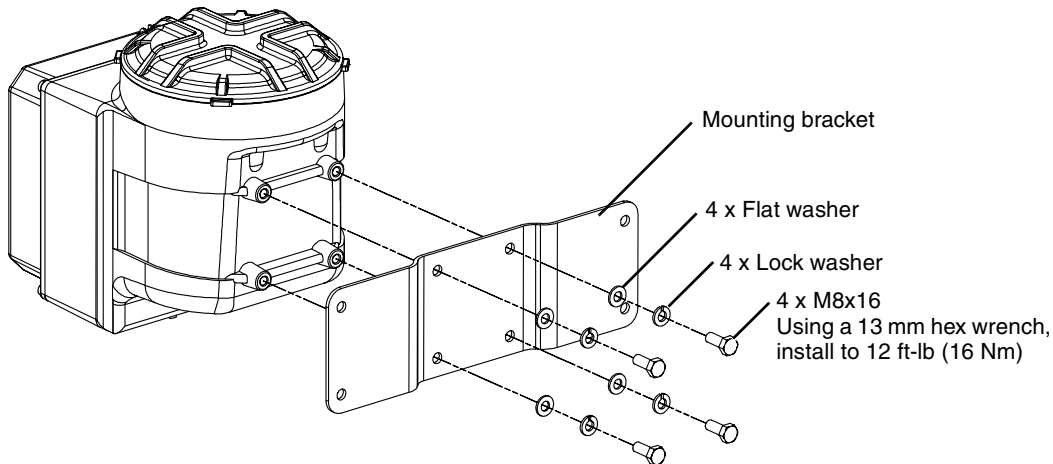
The procedure for field mounting includes the following steps:

1. Choosing an appropriate location for the installation
2. Orienting the display cover for optimal viewing
3. Mounting the applications platform on an instrument pole or flat surface
4. Connecting power-supply wiring
5. Connecting input/output wiring
6. If the applications platform is a Model 3700, connecting the Model 3700 to a sensor. To perform Step 6, see **Chapter 5**.

#### Installation kit for field mounting

The field-mount installation kit includes the parts shown in **Figure 4-1**.

**Figure 4-1. Parts in field-mount installation kit**



### Step 1 Locate and orient the applications platform

<b>⚠ WARNING</b>
<b>Improper installation in a hazardous area could cause an explosion.</b>
Install the applications platform in an area that is compatible with the rating on the approvals tag. See <b>Figure 4-2</b> .

#### Proximity to other devices

- Maximum length of cable from a Micro Motion® sensor to the Model 3700 is 1000 feet (300 meters).
- Maximum length of wiring from the frequency input for a Micro Motion IFT9701 or RFT9739 transmitter is 500 feet (150 meters).

#### Visibility of tags

To ensure personal and system safety, all tags attached to the housing must remain visible. Clean them as often as necessary. Replace tags that are damaged, missing, or worn.

#### Temperature, humidity, and vibration

Install the applications platform according to specified limits:

- Ambient temperature: -4 to 140°F (-20 to 60°C)
- Humidity: SAMA PMC 31.3, Section 5.2, Environmental NEMA 4X (IP65)
- Vibration: Per IEC 68-2-6 at 1.0 g, 15 to 2000 Hz, 50 sweep cycles

#### Orientation

Orient the applications platform so wiring compartments and conduit openings are easily accessible. Conduit openings can be on the right, left, bottom, or top of the housing, regardless of the positions of the display cover or wiring compartments. See **Figure 4-2** and **Figure 4-3**.

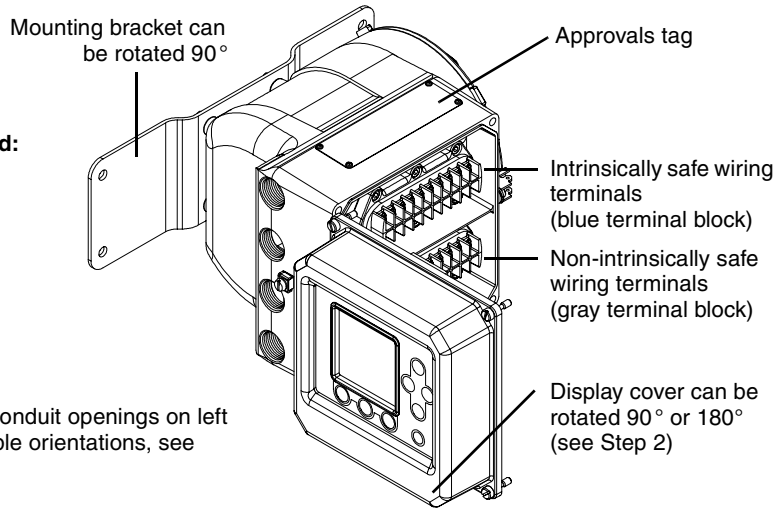
- To orient the applications platform on the mounting bracket, use the four supplied mounting bolt assemblies.
- Install the bolt assemblies to 12 ft-lb (16 Nm) of torque.

**Figure 4-2. Approvals tag and wiring terminals**

**If CENELEC approval is required:**

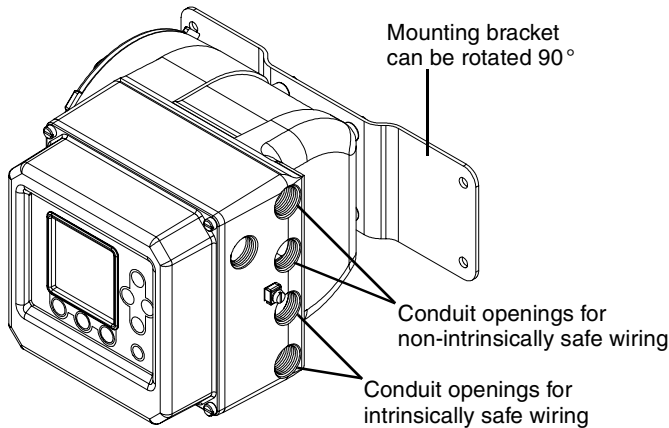
- Remove thread protectors from conduit openings
- Install factory-supplied cable glands or user-supplied EExe cable entry devices in conduit openings that are in use
- Install EExe plugs in conduit openings that are not in use

- Mounting with conduit openings on left
- For other possible orientations, see **Figure 4-3**

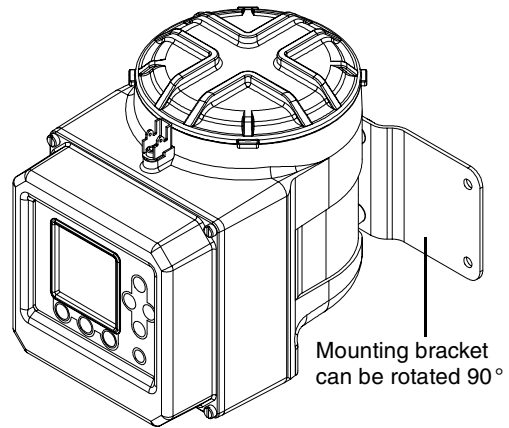


**Figure 4-3. Typical orientations**

Mounting with conduit openings on right



Mounting with conduit openings pointing downward



**Lockout device**

The circuit board compartment has a lockout device, shown in **Figure 4-4**. The lockout device must be loosened and rotated before the compartment cover can be opened.

**Platform approved for ATEX Zone 1**

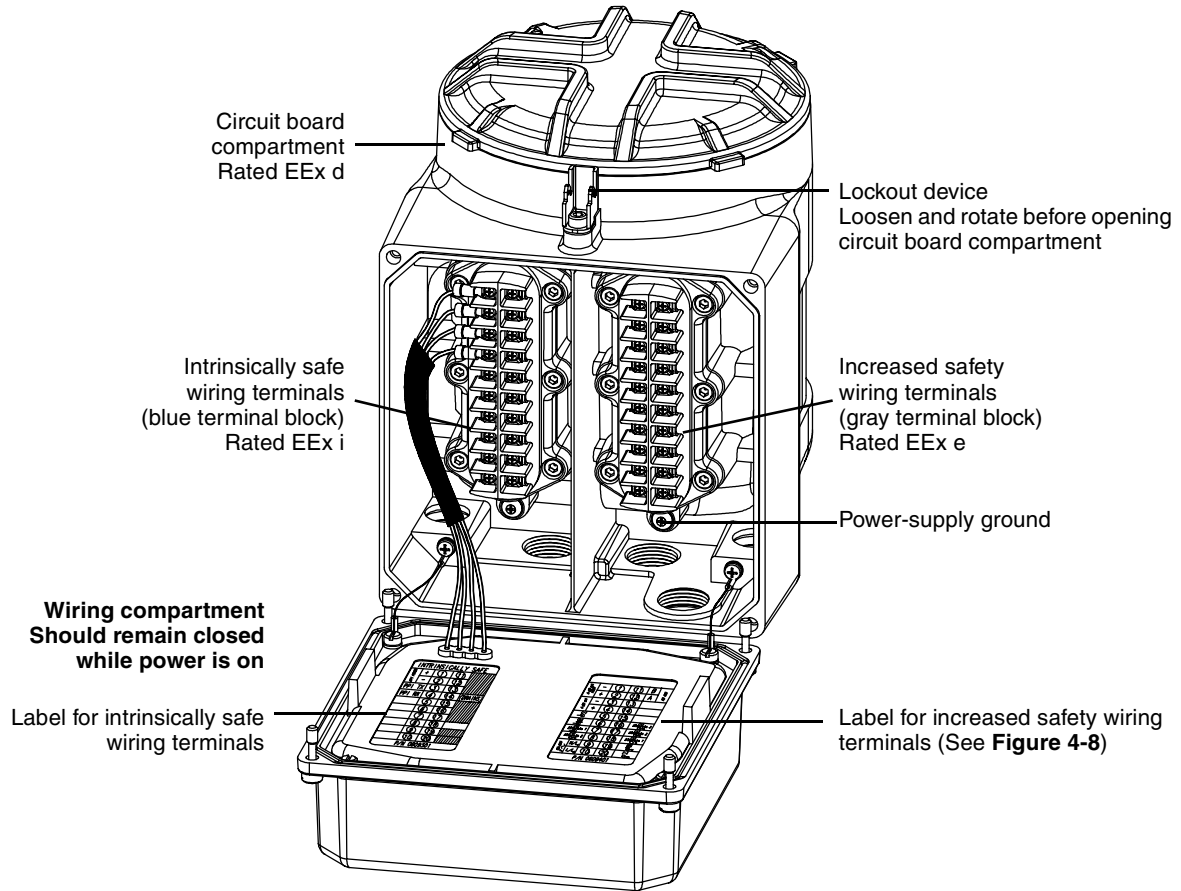
If the applications platform carries a ATEX Zone 1 approval, wiring terminals are rated as shown in **Figure 4-4**.

- Remove thread protectors from conduit openings.
- Install factory-supplied cable glands or user-supplied EExe cable entry devices in conduit openings that are in use.
- Install EExe plugs in conduit openings that are not in use.

The wiring compartments are rated EEx e. They must remain closed when power is on.

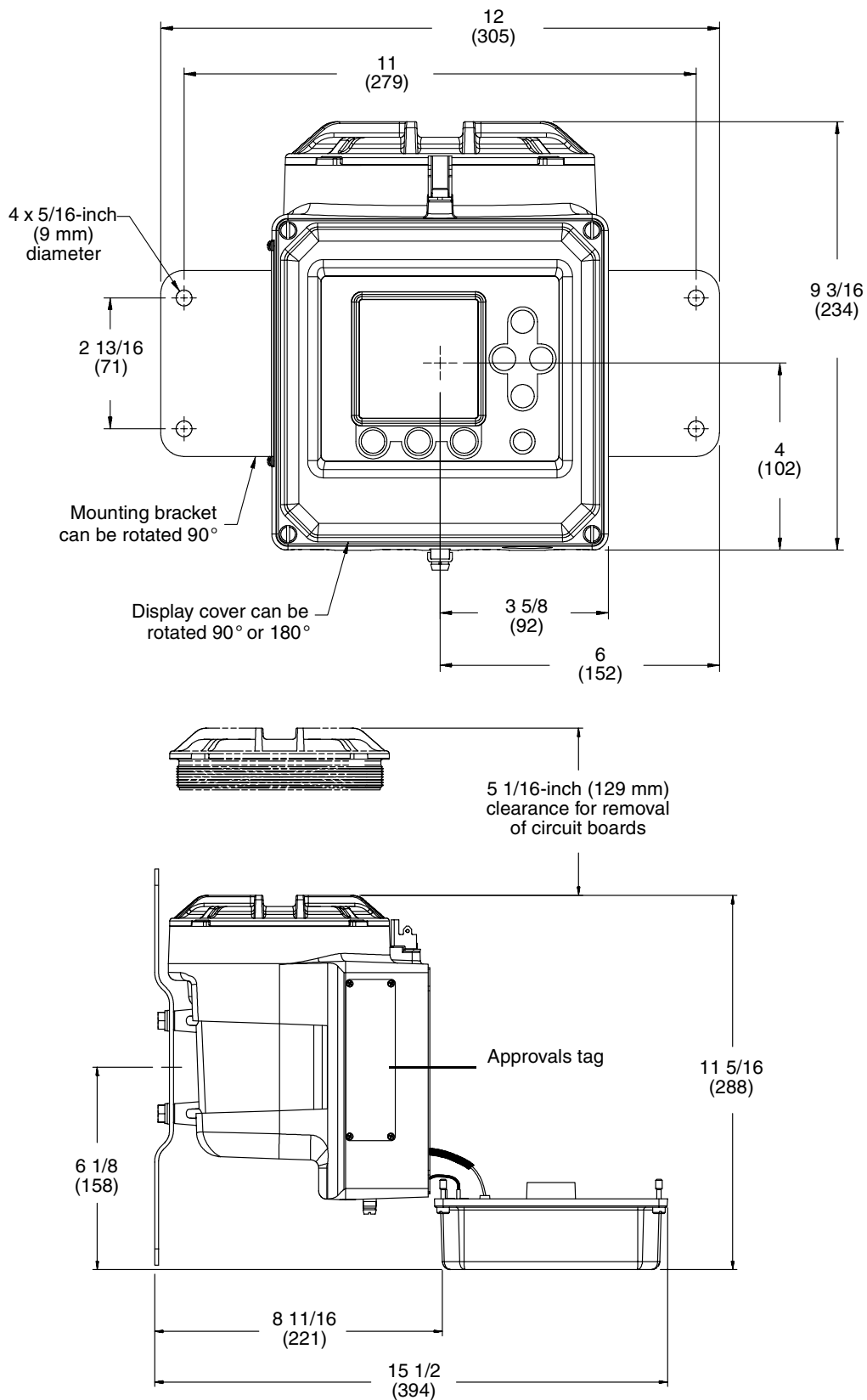
- The wiring terminals on the blue terminal block are rated EEx i (intrinsically safe).
- The wiring terminals on the gray terminal block are rated EEx e (increased safety).

**Figure 4-4. Wiring terminals and lockout device**

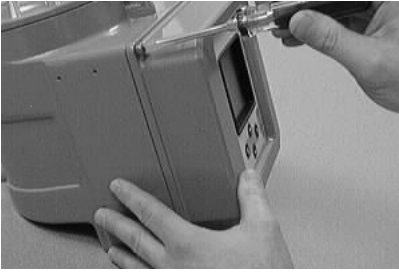




**Figure 4-5. Model 3350 or 3700 dimensions**



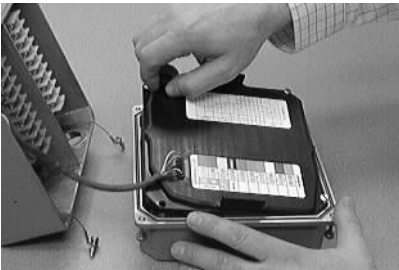
## Step 2 Orient the display cover



- a. Use a flat-head screwdriver to loosen the captive screws that secure the display cover to the housing.



- b. Use a flat-head screwdriver to loosen the captive screws that secure the back cover to the display cover. Take note of which screw attaches the ground wire to the back cover.



- c. Pull up on the pressure relief valve while removing the back cover.



- d. Rotate the display cover to any desired position.



- e. Without touching the circuit board, tuck the wiring out of the way of the circuit board to prevent the wiring from crimping, then reinstall the back cover.



- f. Pull up on the pressure relief valve while pressing the back cover into place. Be sure to attach the ground wire to the back cover using the correct screw. Attaching the ground wire to the wrong screw may result in crimping of the ground wire.



- g. Tuck the wiring out of the way of the connectors to prevent the wiring from crimping, then reinstall the display cover.

### Step 3 Mount the Model 3350 or 3700

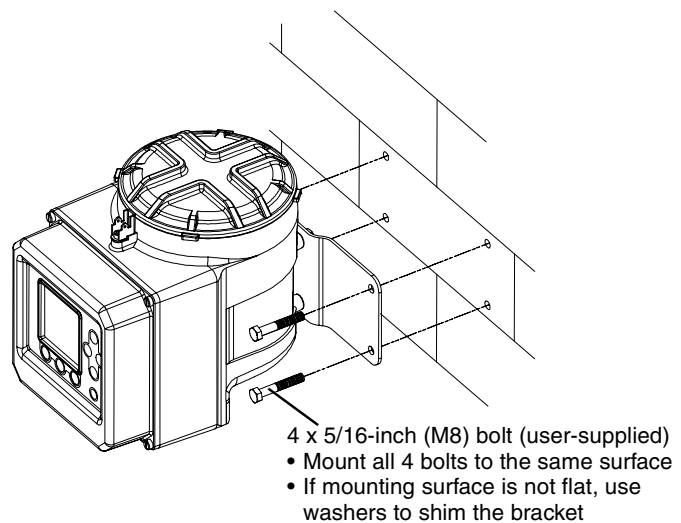
#### Guidelines for flat-surface mounting

- Use four 5/16-inch (M8) lag bolts (not included), suitable for the environment.
- Do not secure bolts to separate beams, girders, wall studs, etc., which can move independently.
- For more information, see **Figure 4-6**.

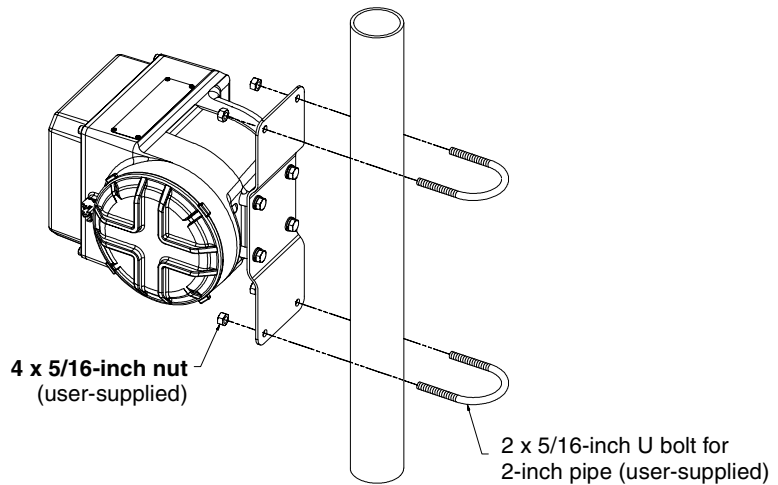
#### Guidelines for pole mounting

- Use two 5/16-inch U bolts for 2-inch pipe, and four 5/16-inch nuts (not included), suitable for the environment.
- For more information, see **Figure 4-7**.

**Figure 4-6. Mounting to a wall or other surface**



**Figure 4-7. Mounting to an instrument pole**



#### Step 4 Connect power-supply wiring

### **⚠ CAUTION**

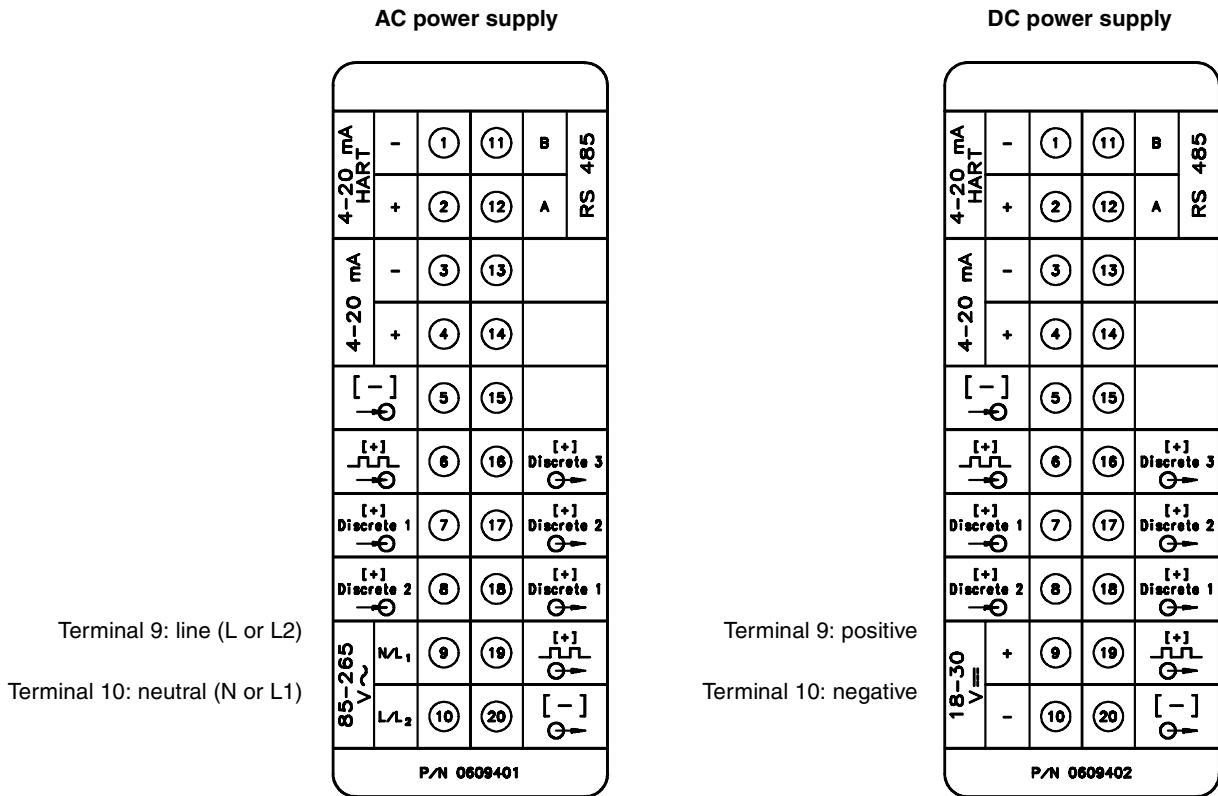
**Improper wiring installation can cause device failure or measurement error.**

- To avoid device failure or measurement error, do not install power-supply wiring in the same cable tray or conduit as input/output wiring.
- Shut off power supply before installing the applications platform.
- Make sure power-supply voltage matches voltage that is indicated on power-supply wiring terminals. See **Figure 4-8**.

Follow these steps to connect 18 to 12 AWG (0,75 to 4,0 mm<sup>2</sup>) wiring to the power-supply wiring terminals.

- a. Using a flat-head screwdriver, loosen the captive screws that secure the display cover to the housing.
- b. Connect the ground wire to green screw.
- c. Connect the green screw directly to earth ground.
  - Keep all ground leads as short as possible.
  - Ground wiring must have less than 1 ohm impedance.
- d. Connect wires to terminals 9 and 10 on the gray terminal strip. See **Figure 4-8**.
  - If the Model 3700 has a DC power supply, terminal 9 is positive (+), terminal 10 is negative (-).
  - If the Model 3700 has an AC power supply, terminal 9 is line (L or L2), terminal 10 is neutral (N or L1).
- e. A switch may be installed in the power-supply line. For compliance with low-voltage directive 73/23/EEC, a switch in close proximity to the applications platform is required.

Figure 4-8. Field-mount input/output wiring terminals



### Step 5 Connect input and output wiring

Follow these steps to connect twisted-pair, shielded wiring, 22 to 16 AWG (0,34 to 1,5 mm<sup>2</sup>), to the input/output wiring terminals.

- a. Using a flat-head screwdriver, loosen the captive screws that secure the display cover to the housing.
- b. Connect input/output wiring to the gray terminal strip.
  - Ground the shields at the field device.
  - Clip the shields at the end that connects to the applications platform.
  - If more than two wires must be connected to a single terminal, use a butt splice or spade lug to connect the wires.

A label that is attached to the back of the display cover shows terminal designations for input/output wiring.

- See **Figure 4-8** and **Table 4-1**.
- Input and output assignments depend on the application. For more information, see the *Series 3000 Detailed Setup Manual*.

**Table 4-1. Field-mount input/output wiring terminals**

Terminal number		Designation
1 –	2 +	Primary 4-20 mA output
3 –	4 +	Secondary 4-20 mA output
5 –	6 +	Frequency input
5 –	7 +	Discrete input 1
5 –	8 +	Discrete input 2
11 (B line)	12 (A line)	RS-485 output
20 –	16 +	Discrete output 3
20 –	17 +	Discrete output 2
20 –	18 +	Discrete output 1
20 –	19 +	Frequency output

### Step 6 **Connect the Model 3700 to the sensor**

To connect the Model 3700 transmitter to a Micro Motion® sensor, see **Chapter 5**.

# 5

## Connecting the Transmitter to a Sensor

### 5.1 About this chapter

This chapter explains how to connect the Model 3500 or 3700 transmitter to a Micro Motion ELITE®, T-Series, BASIS®, Model D, Model DL, or Model DT sensor. For other sensors, see the sensor installation manual.

- Use Micro Motion 9-wire cable to connect the transmitter to the sensor.
- Total length of cable from sensor to transmitter must not exceed 1000 feet (300 meters).

#### **WARNING**

**Failure to maintain intrinsic safety could result in an explosion.**

To keep sensor wiring intrinsically safe:

- Keep intrinsically safe sensor wiring separated from power-supply and output wiring.
- Do not install power cable in the same conduit or cable tray as flowmeter cable.
- Use this document with Micro Motion ATEX, UL, or CSA installation instructions that are shipped with the sensor.

#### **CAUTION**

**Improper installation of cable, cable gland, or conduit could cause inaccurate measurements or flowmeter failure.**

To ensure 360° termination of shielding for flowmeter wiring, install the factory-supplied cable gland or user-supplied sealed metallic conduit to the conduit opening on the sensor junction box.

## 5.2 Cable types

Micro Motion supplies 9-wire jacketed, shielded, or armored cable.

- Jacketed cable is CE-compliant when it is installed inside user-supplied sealed metallic conduit that provides 360° termination shielding and continuous coverage for the enclosed cable.
- Shielded and armored cable are CE-compliant when the cable is installed with the factory-supplied cable glands.
- Shielded and armored cable are acceptable for cable tray installation.
- Each cable type is available with a PVC or Teflon® FEP jacket. For temperature ranges of cable jacket materials, see **Table 5-1**.
- Use shielded or armored cable with Micro Motion T-Series sensors.

### CAUTION

**Failure to use shielded or armored cable with Micro Motion T-Series sensors could cause inaccurate measurements.**

Install Micro Motion shielded or armored cable with Micro Motion T-Series sensors.

## 5.3 Cable and conduit preparation

Prepare cable and conduit according to the cable preparation instructions that are shipped with the sensor.

### Guidelines for cable gland

1. Prepare cable ends and assemble the supplied cable gland according to the instructions that are enclosed with the cable preparation kit.
2. Connect the 3/4-inch NPT male cable gland to the 3/4-inch NPT female conduit opening on the sensor junction box.

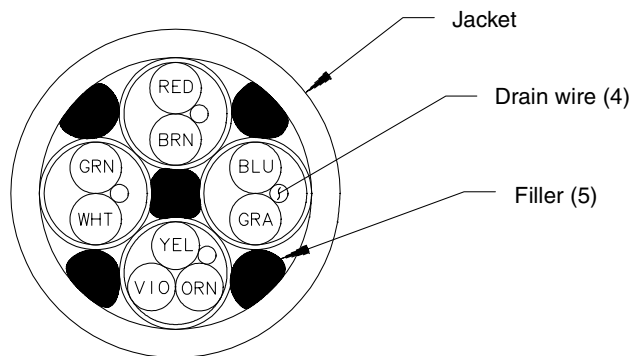
### Guidelines for conduit

If sealed metallic conduit is installed, it must provide 360° termination shielding for the enclosed flowmeter cable.

1. Install a drip leg in conduit to prevent liquids from entering the junction box.
2. Connect the sealed end of the conduit to the 3/4-inch NPT female conduit opening on the sensor junction box.

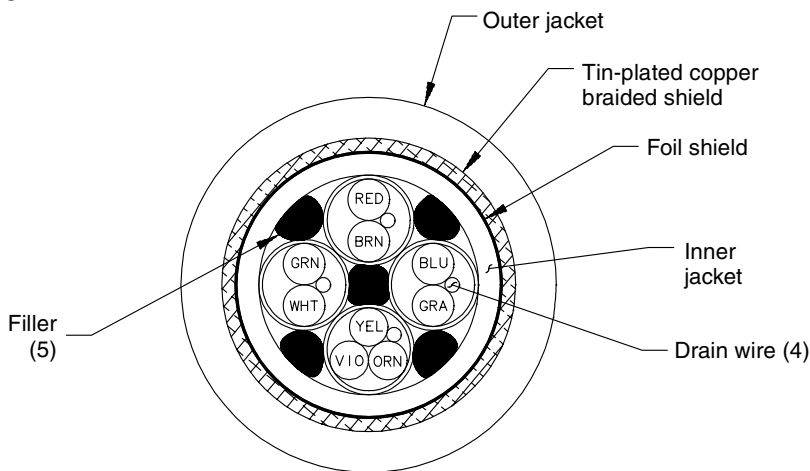


**Figure 5-1. Jacketed cable**



Jacket material	Outside diameter		Minimum bend radii			
	inches	(mm)	Static (no load)		Dynamic load	
PVC	.415	(10)	3 1/8	(80)	6 1/4	(159)
Teflon FEP	.340	(9)	2 5/8	(67)	5 1/8	(131)

**Figure 5-2. Shielded cable**

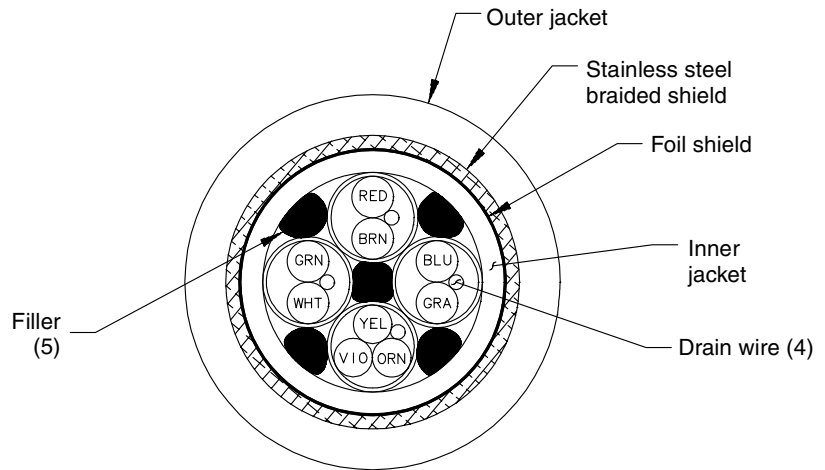


**Note for Figure 5-2**

You must install shielded or armored cable with Micro Motion T-Series sensors.

Jacket material	Outside diameter		Minimum bend radii			
	inches	(mm)	Static (no load)		Dynamic load	
PVC	.560	(14)	4 1/4	(108)	8 1/2	(216)
Teflon FEP	.425	(11)	3 1/4	(83)	6 3/8	(162)

**Figure 5-3. Armored cable**



**Note for Figure 5-3**

You must install shielded or armored cable with Micro Motion T-Series sensors.

Jacket material	Outside diameter		Minimum bend radii			
	inches	(mm)	Static (no load)		Dynamic load	
			inches	(mm)	inches	(mm)
PVC	.560	(14)	4 1/4	(108)	8 1/2	(216)
Teflon FEP	.425	(11)	3 1/4	(83)	6 3/8	(162)

**Table 5-1. Temperature ranges for cable jacket material**

Cable jacket material	Low operating temperature limit	High operating temperature limit
PVC	-40 °F (-40 °C)	221 °F (105 °C)
Teflon FEP	-76 °F (-60 °C)	302 °F (150 °C)

**Table 5-2. Requirements for CE Mark in Europe, recommendations for elsewhere**

Installation requirements	Jacketed cable	Shielded cable	Armored cable
Conduit is used	X		
Conduit is not used		X	
Conduit is not used and mechanical protection is required			X
Micro Motion T-Series sensor is being installed		X	X

### 5.4 Wiring connections to sensor

1. Insert the ends of the individual wires into the terminals inside the sensor junction box. No bare wires should remain exposed.
2. Match the wire colors of the cable with the wire colors at the sensor wiring terminal as described in **Table 5-3**.
3. If possible, position the junction box so the conduit entrance points downward to prevent moisture from entering.

**⚠ CAUTION**

**Failure to seal sensor junction box or transmitter housing could cause a short circuit, which would result in measurement error or flowmeter failure.**

To avoid risk of condensation or excessive moisture entering the junction box or transmitter housing:

- Seal all conduit openings.
- Install drip legs in cable or conduit.
- Fully tighten sensor junction box and transmitter housing covers.

**Table 5-3. Sensor terminal designations**

Terminal number	Wire color	Function
1	Brown	Drive +
2	Red	Drive –
3	Orange	Temperature –
4	Yellow	Temperature lead length compensator
5	Green	Left pickoff +
6	Blue	Right pickoff +
7	Violet	Temperature +
8	Gray	Right pickoff –
9	White	Left pickoff –

### 5.5 Wiring connections to transmitter

The procedure for connecting sensor wiring to the transmitter depends on the type of wiring connections.

#### Screw-type or solder-tail connectors

Connect the ends of the individual wires to the appropriate terminals. No bare wires should remain exposed.

- Match the wire colors of the cable with the wire colors at the sensor wiring terminals. To connect to a Micro Motion ELITE, T-Series, BASIS, Model D, or Model DL sensor, see **Table 5-4, Figure 5-5, and Figure 5-6**.
- To connect to a Model DT sensor, see **Table 5-4, Figure 5-7, and Figure 5-8**.

#### I/O cables

1. Attach the supplied terminal block to a DIN rail. The terminal block accommodates various rail types. See **Figure 5-4**.
2. Plug the sensor I/O cable connector onto the terminal block. Tighten the captive screws to secure the connector to the terminal block.
3. Connect the ends of the individual wires of the sensor cable to the appropriate terminals on the terminal block. No bare wires should remain exposed.

Connecting the Transmitter to a Sensor *continued*

4. Match the wire colors of the cable with the wire colors at the sensor wiring terminals.
  - To connect to a Micro Motion ELITE, T-Series, BASIS, Model D, or Model DL sensor, see **Table 5-4** and **Figure 5-5**.
  - To connect to a Model DT sensor, see **Table 5-4** and **Figure 5-7**.

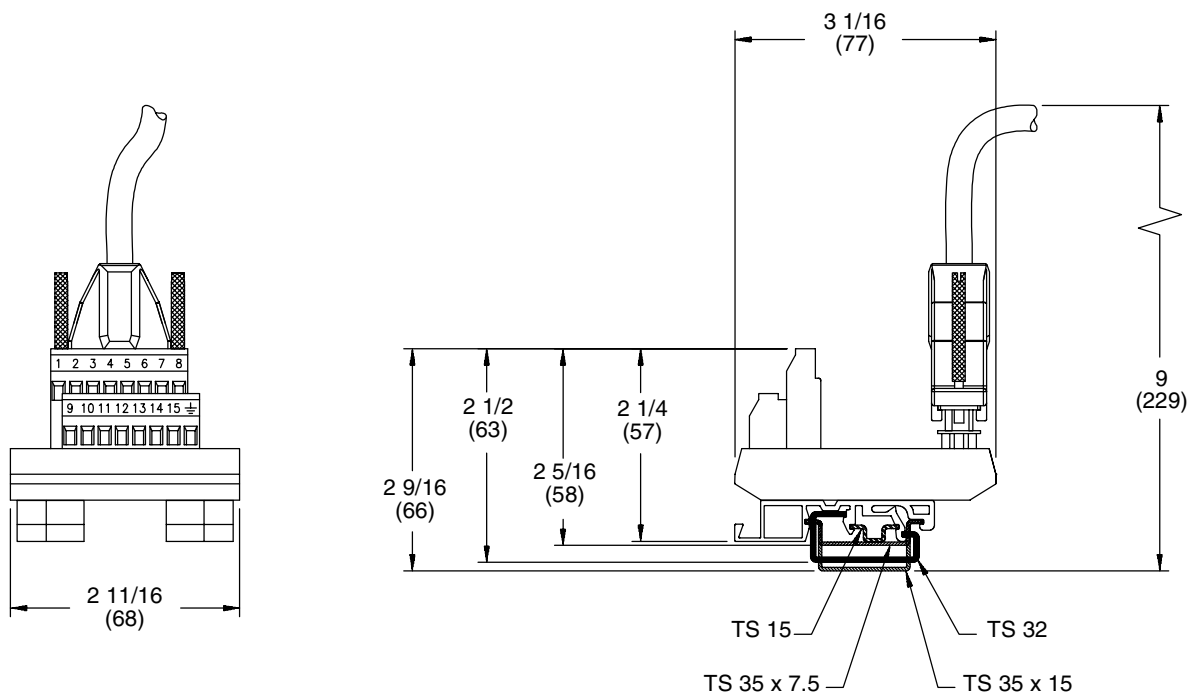
The I/O cables do not have CENELEC approval.

**Table 5-4. Transmitter terminals for sensor cable**

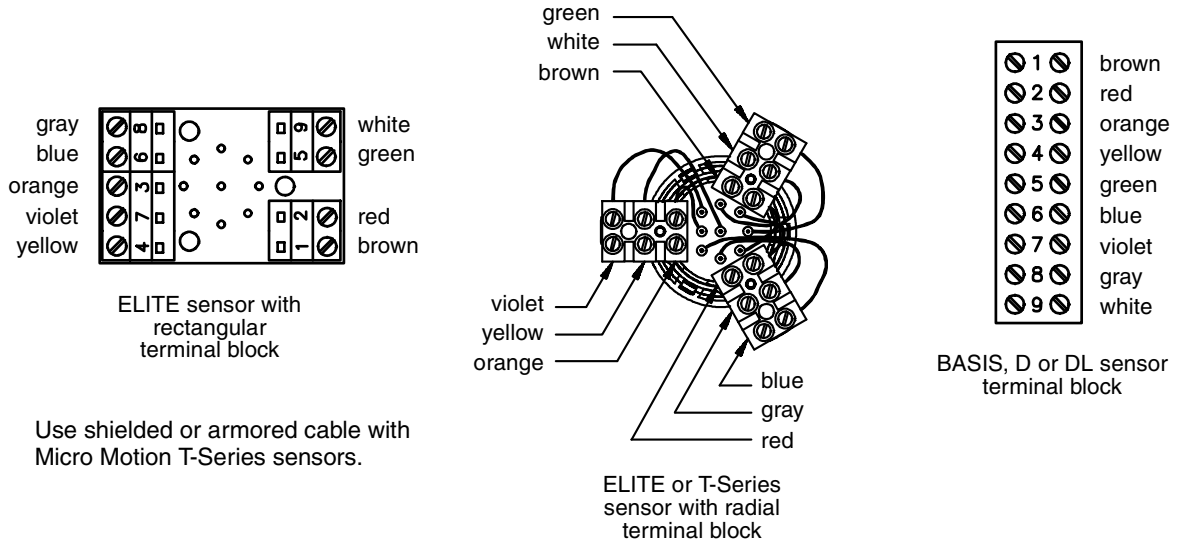
Transmitter terminal numbers				
Model 3500 with I/O cable	Model 3500 with screw-type or solder-tail terminals	Model 3700	Wire color	Function
4	c 4	13	Yellow	Temperature lead length compensator
10	a 4	14	Black*	Drain wires
7	c 6	15	Violet	Temperature +
3	a 6	16	Orange	Temperature -
5	c 8	17	Green	Left pickoff +
9	a 8	18	White	Left pickoff -
6	c 10	19	Blue	Right pickoff +
8	a 10	20	Gray	Right pickoff -
1	c 12	12	Brown	Drive +
2	a 12	11	Red	Drive -

\*Combined drain wires from brown/red, green/white, and gray/blue pairs and yellow/orange/violet triplet.

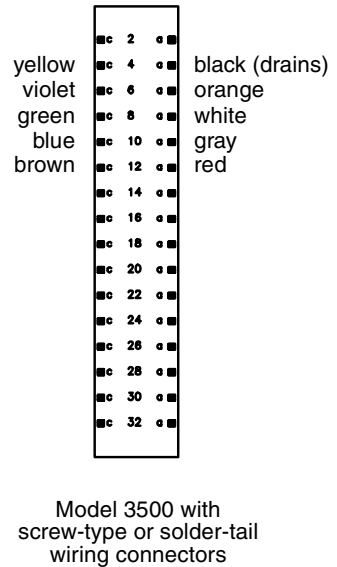
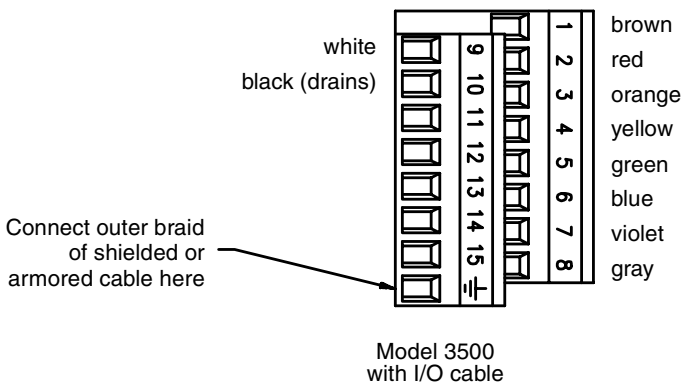
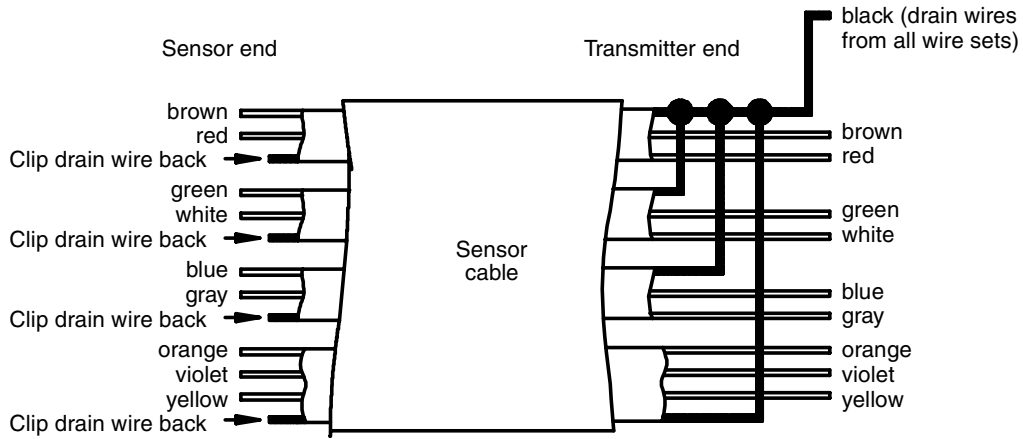
**Figure 5-4. Installing sensor wiring terminal block on DIN rail**



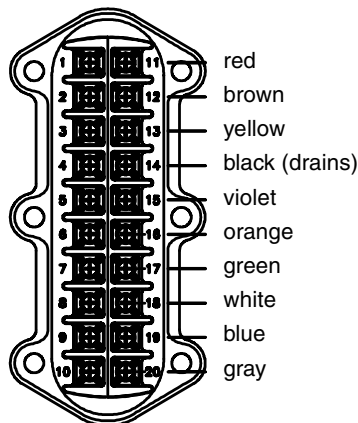
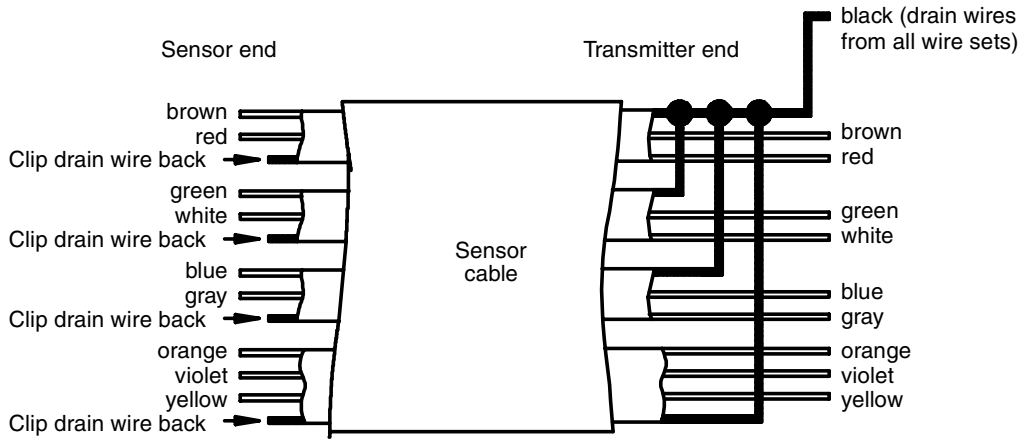
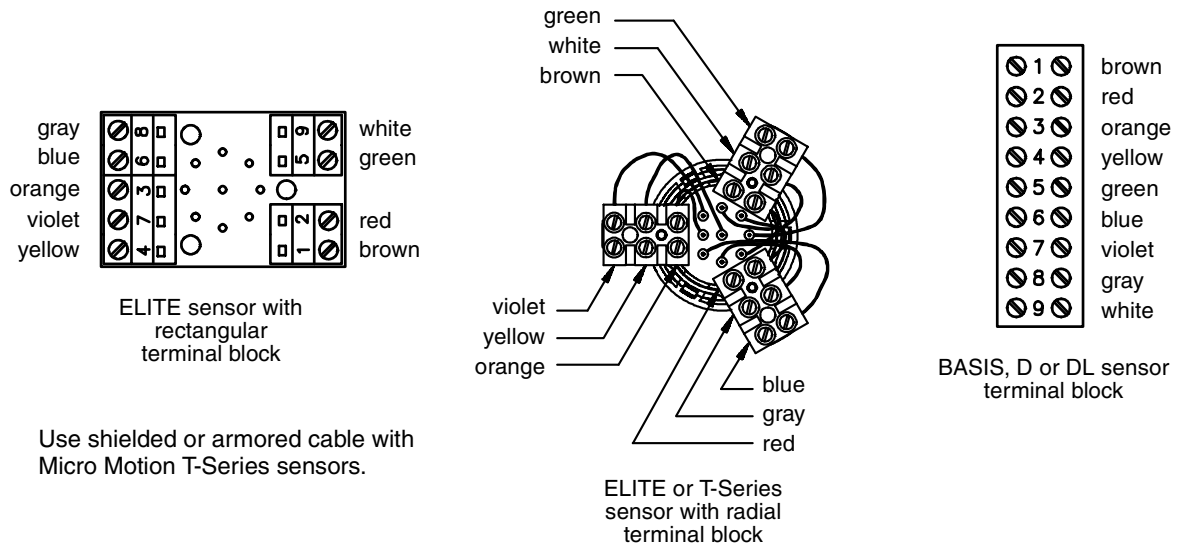
**Figure 5-5. Cable connections: Model 3500 to ELITE®, T-Series, BASIS®, Model D, or Model DL sensor**



Use shielded or armored cable with Micro Motion T-Series sensors.

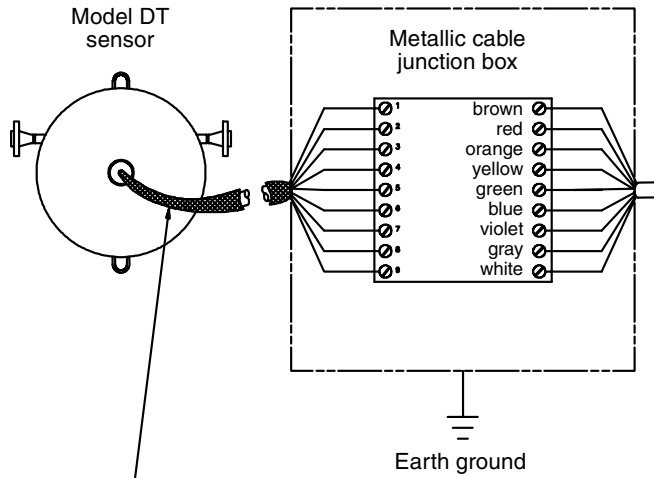


**Figure 5-6. Cable connections: Model 3700 to ELITE®, T-Series, BASIS®, Model D, or Model DL sensor**

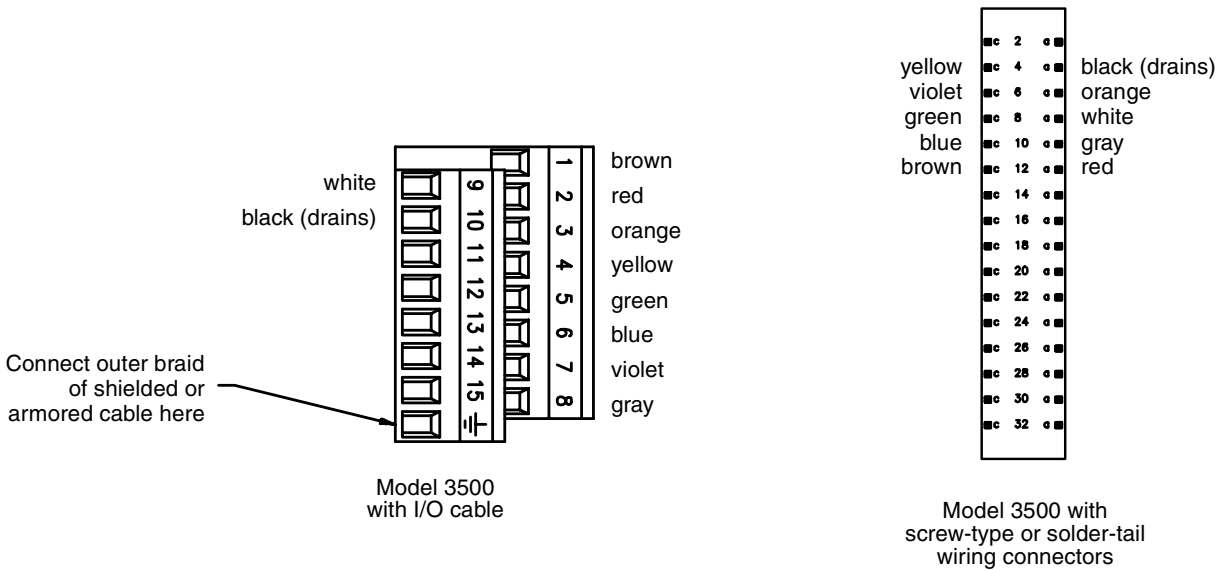
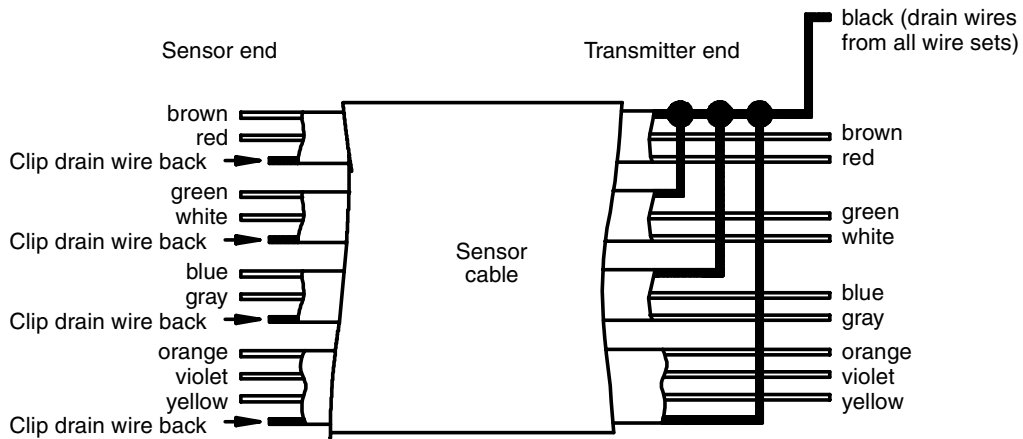


Model 3700 wiring terminals (blue terminal block)

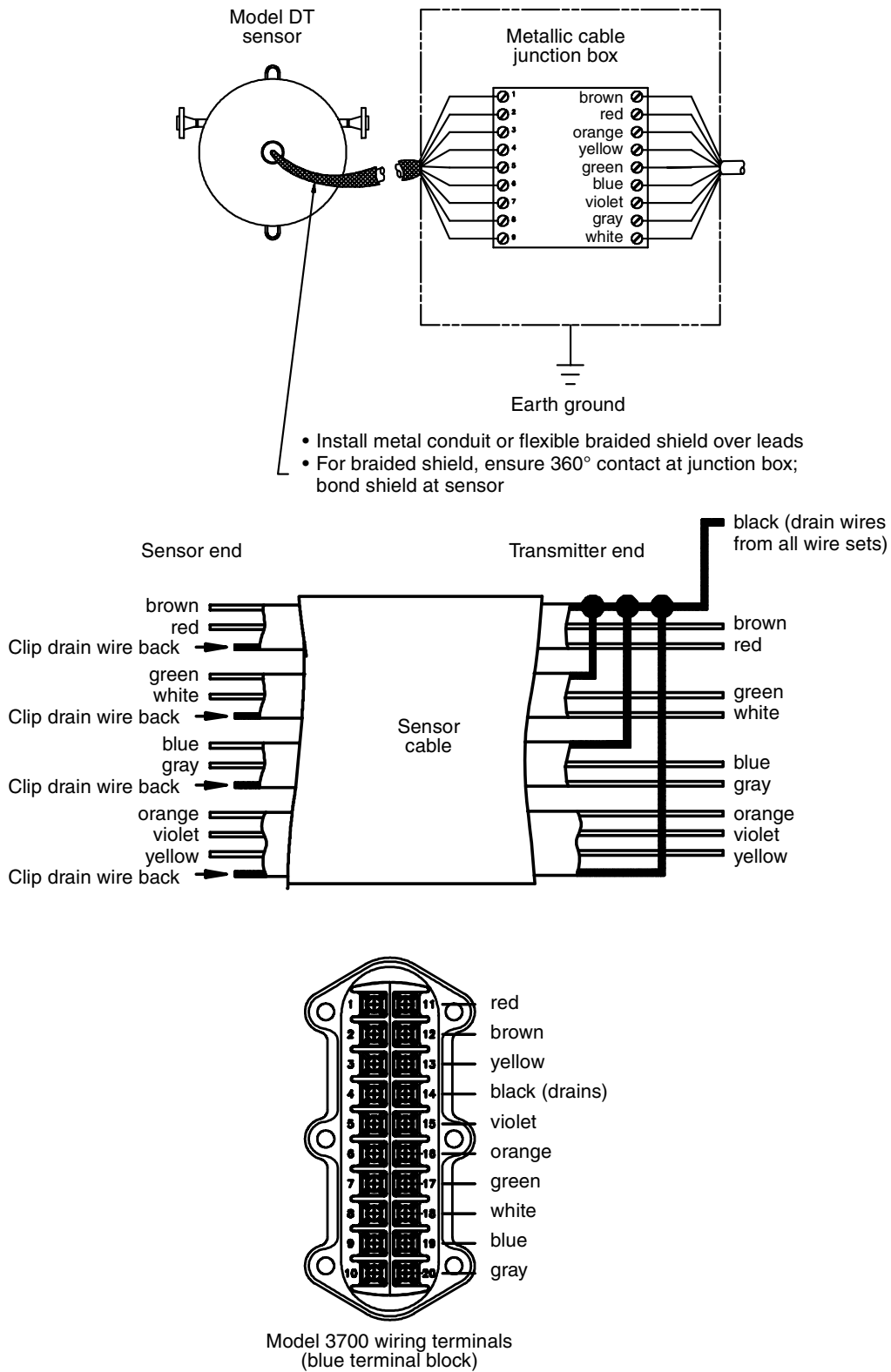
**Figure 5-7. Cable connections: Model 3500 to Model DT sensor**



- Install metal conduit or flexible braided shield over leads
- For braided shield, ensure 360° contact at junction box; bond shield at sensor



**Figure 5-8. Cable connections: Model 3700 to Model DT sensor**





# 6

## Installing Relays

### 6.1 About this chapter

This chapter explains how to install relays for the Series 3000 applications platform.

- To install optional solid-state relays supplied by Micro Motion®, see **Section 6.6**. Factory-supplied relays are internally powered.
- To install user-supplied relays, see **Section 6.7**. User-supplied relays can be internally or externally powered.

After relays have been installed, discrete outputs must be configured for operation with an internal or external power source. See **Section 6.8**.

### 6.2 Specifications for user-supplied relays

If user-supplied relays are internally powered, they must be solid-state relays that are compatible with the Series 3000 discrete outputs.

If user-supplied relays are externally powered, they may be mechanical relays that are compatible with the Series 3000 discrete outputs.

Three discrete outputs are configurable for the application.

- Power: Internal or external, software selectable
- Voltage: 24 VDC nominal
- Current: Sourcing at 5.6 mA when  $V_{out} = 3$  VDC  
Sinking up to 500 mA at 30 VDC supply maximum

### 6.3 Hazardous area installations

If you are installing the relay or relay module in a hazardous area, review the information in this section.

#### Model 3100 relays

#### ATEX

Model 3100 relay modules are suitable for installation in Zone 2, complying with ATEX Directive (94/9/EC) for Group II, Category 3G, according to CENELEC standard prEN 50021:1998 and marked as:

- EEx n V II T4
- KEMA 97 ATEX 4940 X
- Ambient temperature  $-20$  to  $+60$  °C ( $-4$  to  $+140$  °F)

To comply with hazardous area requirements:

- Model 3100 relay modules must be mounted into a suitable and classified enclosure that provides ingress protection of at least IP4X according to EN 60529, taking into account the environmental conditions into which the equipment will be installed and clause 6 of prEN50021:1998.
- Cable entries for the enclosure shall comply with clause 7.2.6 of prEN50021:1998.
- The external metal parts of the relay module (heat sinks) must be connected to the potential equalizing system within the hazardous area.

### UL and CSA

Model 3100 relay modules are suitable for installation in Class I, Division 2, Groups A, B, C, and D.

For CSA compliance, the relay module must be installed in a suitable enclosure where the final combination is subject to acceptance by the Canadian Standards Association (CSA).

### User-supplied relays

User-supplied relays to be used for Zone 2 applications must be certified as Category 3 equipment.

### 6.4 Replacing relays

You may not replace a defective relay separately. If an individual relay is defective, you must replace the entire relay module.

This requirement applies to both the Model 3100 and to user-supplied relays, and to both hazardous and non-hazardous areas.

### 6.5 Software configuration

Relays connect to discrete outputs from the applications platform.

- Discrete outputs can operate from an internal or external power source.
- For more information about configuring discrete outputs, see **Section 6.8**.

#### CAUTION

**Improper configuration of the software can cause relays to be activated.**

Before startup, make sure discrete output power source is configured as "internal" if relays are energized by this unit; or configured as "external" if relays are energized by an external power source.

Use the Series 3000 software to select an internal or external power source for the discrete outputs that are connected to the relays.

- If relays are internally powered, select an internal power source for the discrete outputs. (Internal power source is the default.)
- If relays are externally powered, select an external power source for the discrete outputs.

## 6.6 Installing factory-supplied relays

To install factory-supplied (internally powered) solid-state relays, follow these steps:

1. Mount the relay terminal block to a DIN rail. See **Figure 6-1**.
2. Connect wiring from the applications platform to the relay terminal block. See **Figure 6-2**, **Figure 6-3**, and **Figure 6-4**.
3. Connect wiring from the relay terminal block to the devices the relays will control. See **Figure 6-5** and **Figure 6-6**.

### **WARNING**

#### **Shock Hazard.**

Improper installation of wiring, or installation with power supply on, can cause electric shock or property damage.

For personal and system safety:

- Shut off power before installing wiring.
- Make sure the installation meets or exceeds local code requirements.
- Install relays and wiring in accordance with the illustrations in these instructions.
- Install relays and wiring where ambient temperature remains between  $-4$  and  $140^{\circ}\text{F}$  ( $-20$  and  $60^{\circ}\text{C}$ ).

### **WARNING**

#### **Explosion Hazard.**

Improper installation of relays can cause ignition of explosive atmospheres.

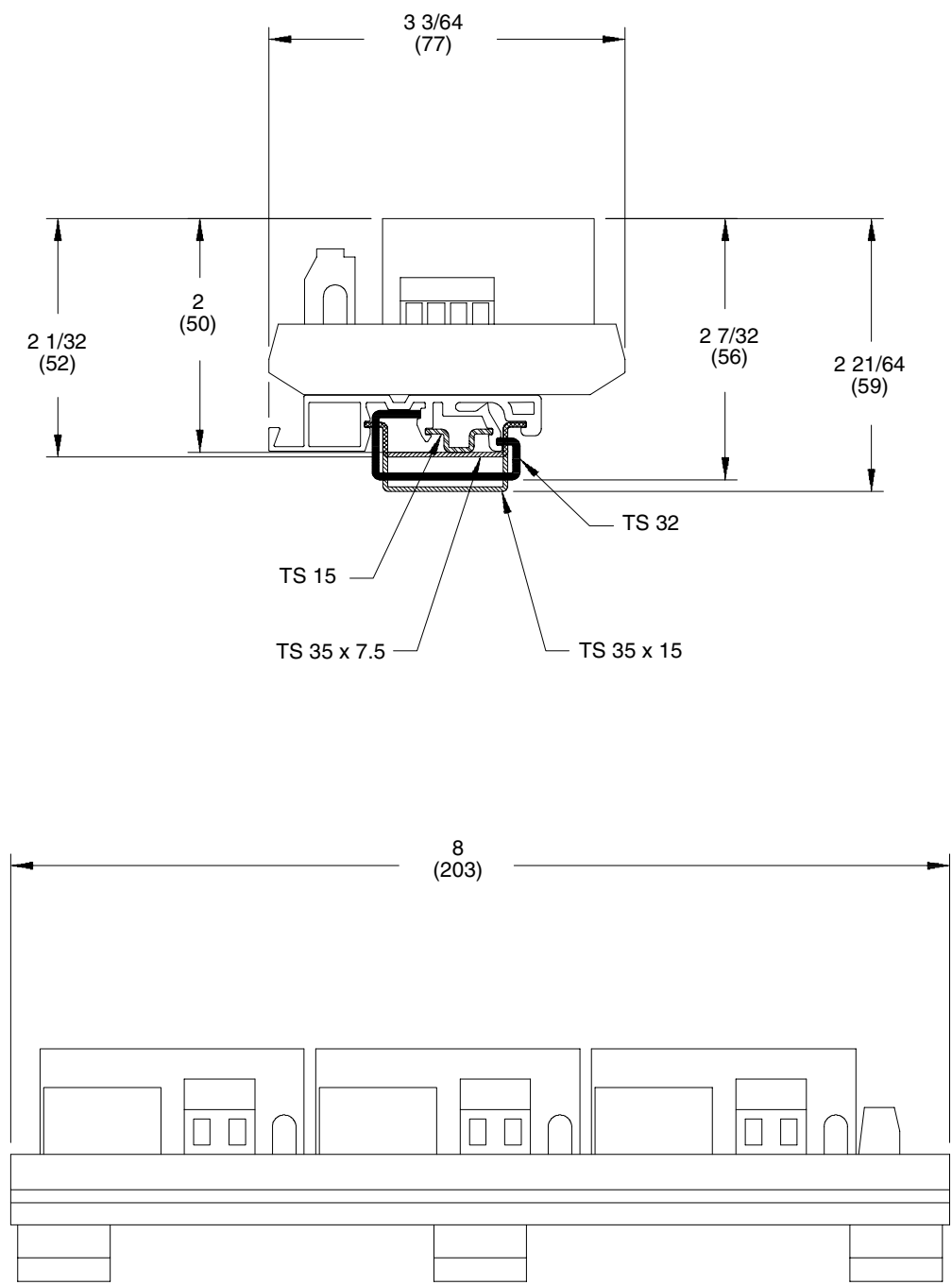
For personal and system safety:

- Ensure relay contact ratings are:
  - 0.04 to 5 amps at 24 to 280 Volts AC (RMS) or
  - 0.02 to 5 amps at 0 to 70 Volts DC.
- Ensure correct polarity of diode and power source.

### Step 1 Mount relay terminal block

Mount the supplied relay terminal block to a DIN rail. The terminal block accommodates various standard rail types. See **Figure 6-1**.

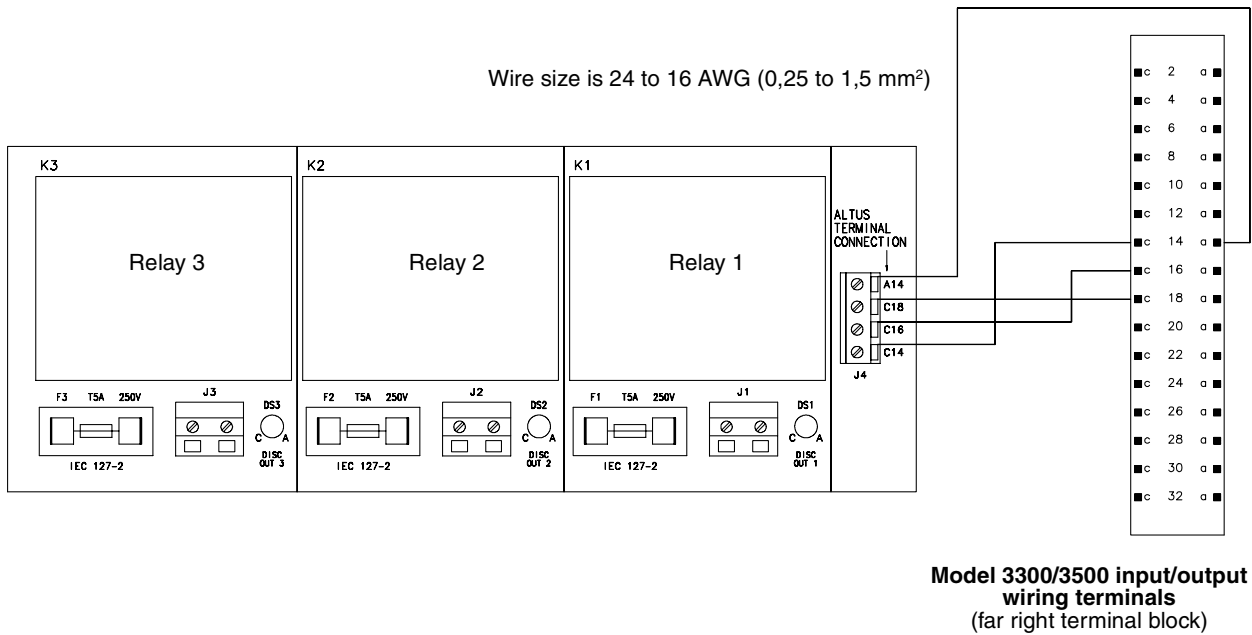
**Figure 6-1. Relay terminal block dimensions**



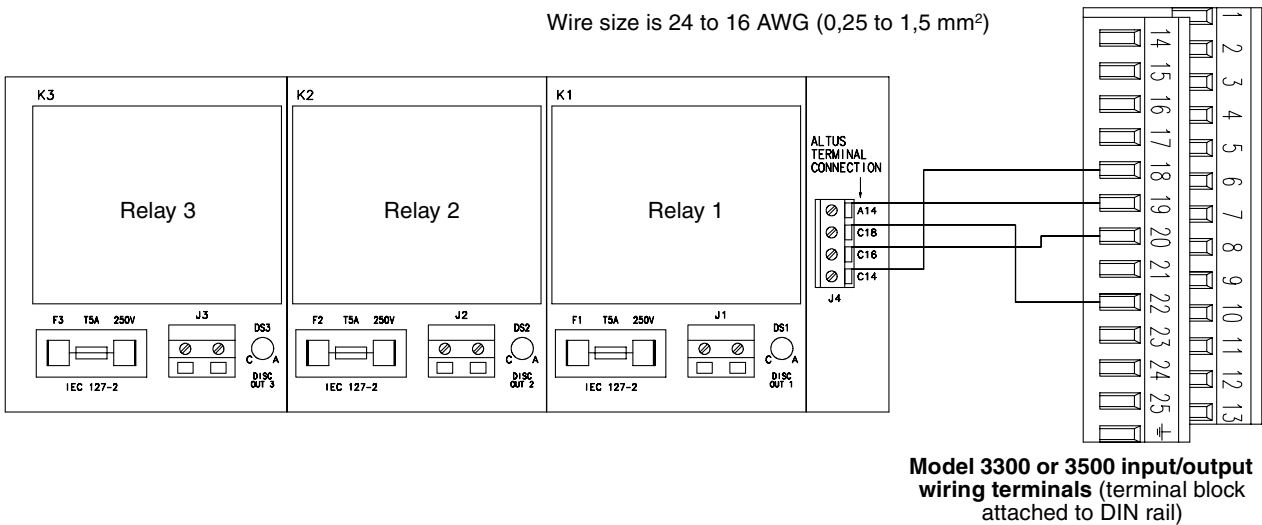
## Step 2 Connect wiring to relays

- Wire size is 24 to 16 AWG (0,25 to 1,5 mm<sup>2</sup>) for the Model 3300 or 3500; 22 to 16 AWG (0,34 to 1,5 mm<sup>2</sup>) for the Model 3350 or 3700.
- One relay, two relays, or all three relays may be connected.
- For a Model 3300 or 3500 with screw-type or solder-tail connectors, see **Figure 6-2**.
- For a Model 3300 or 3500 with I/O cables, see **Figure 6-3**.
- For a Model 3350 or 3700, See **Figure 6-4**.

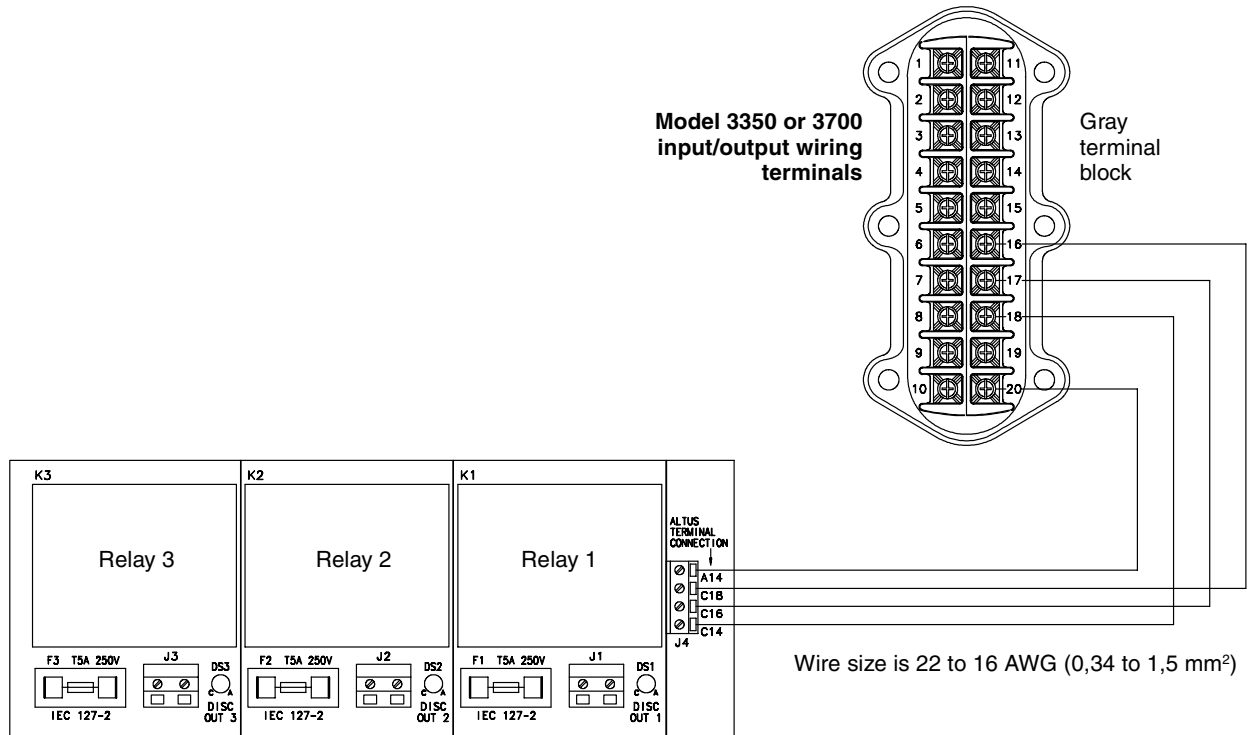
**Figure 6-2. Relay wiring: Screw-type or solder-tail connector**



**Figure 6-3. Relay wiring: I/O cable**



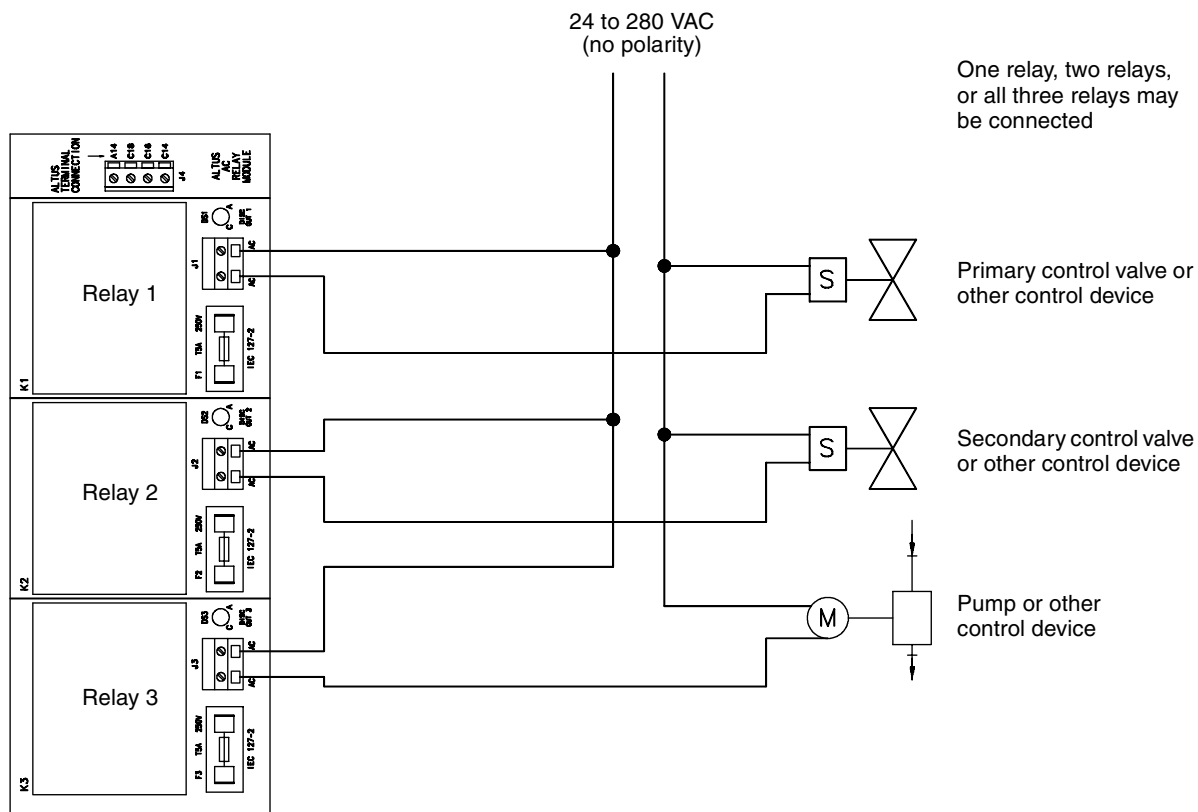
**Figure 6-4. Relay wiring: Model 3350 or 3700**



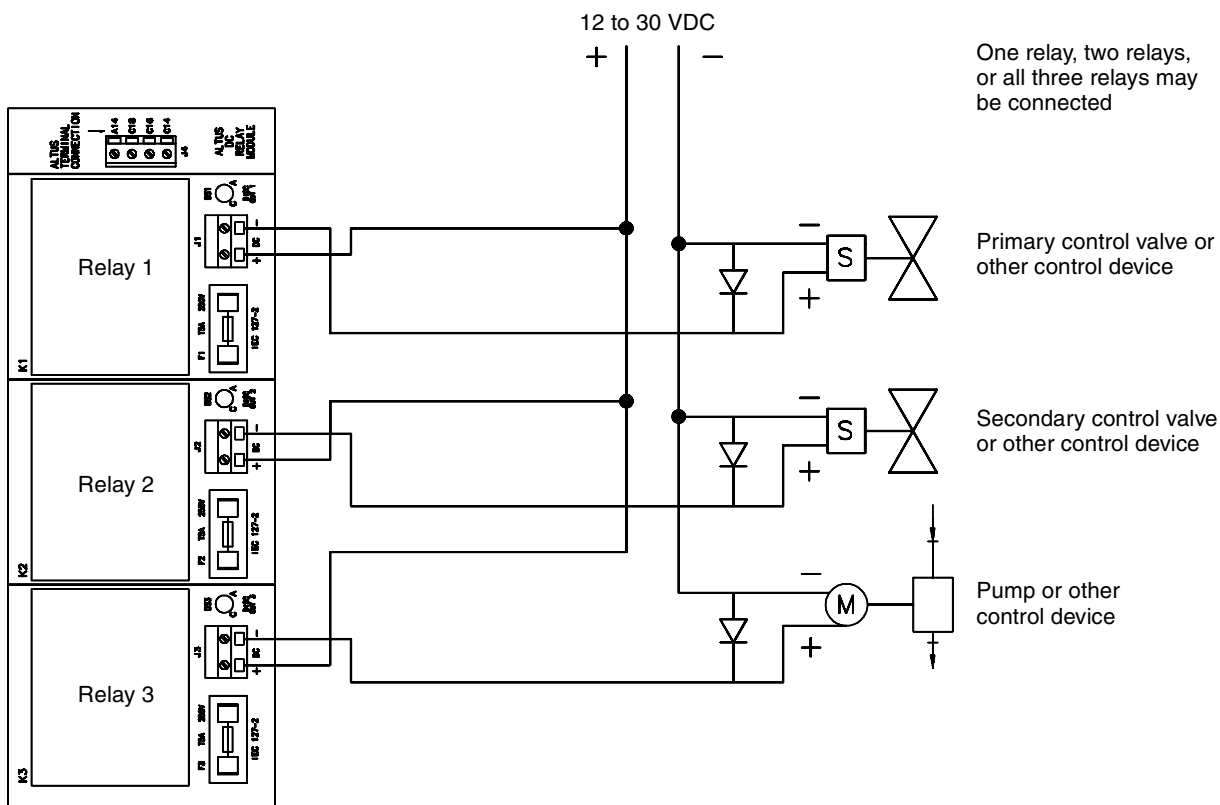
### Step 3 Connect wiring to control devices

- If the relay loads have an AC power supply, see **Figure 6-5**. AC output terminals do not have polarity.
- If the relay loads have a DC power supply, see **Figure 6-6**. DC output terminals have polarity.

**Figure 6-5. Wiring to control devices, AC power**



**Figure 6-6. Wiring to control devices, DC power**



## 6.7 Installing user-supplied relays

To install user-supplied relays, follow these steps:

1. Connect wiring from the applications platform to the relays.
2. Connect wiring from the relays to the devices the relays will control.
  - User-supplied relays may be internally or externally powered.
  - User-supplied AC solid-state relays are internally powered, and should be a zero-crossing type requiring less than 5.6 mA current to energize the relays. (The relay will switch the output on or off when the output voltage reaches 0 V.)

### **WARNING**

#### **Shock Hazard.**

Improper installation of wiring, or installation with power supply on, can cause electric shock or property damage.

For personal and system safety:

- Shut off power before installing wiring.
- Make sure the installation meets or exceeds local code requirements.
- Install relays and wiring in accordance with the illustrations in these instructions.
- Install relays and wiring where ambient temperature remains between -4 and 140 °F (-20 and 60 °C).

### **WARNING**

#### **Explosion Hazard.**

Improper installation of relays can cause ignition of explosive atmospheres.

For personal and system safety, use the following input ratings for user-supplied relays:

- If the applications platform serves as the power source, voltage is 24 VDC nominal; current is 5.6 mA when output voltage = 3 VDC.
- If the current requirements are higher than 5.6 mA, configure the applications platform to sink current up to a maximum of 500 mA at 30 VDC supply maximum, and use an external power source appropriate for the relays.

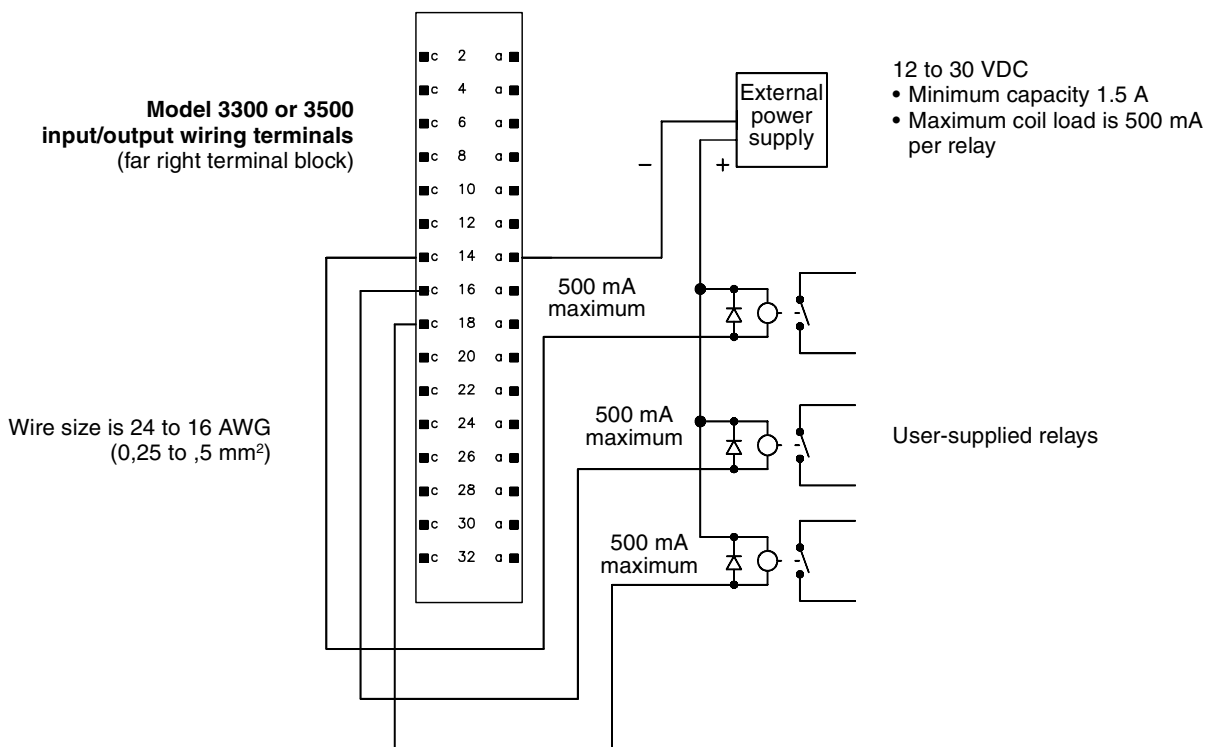
For information about configuring the power source for user-supplied relays, see **Section 6.8**.

## Step 1 Connect wiring to relays

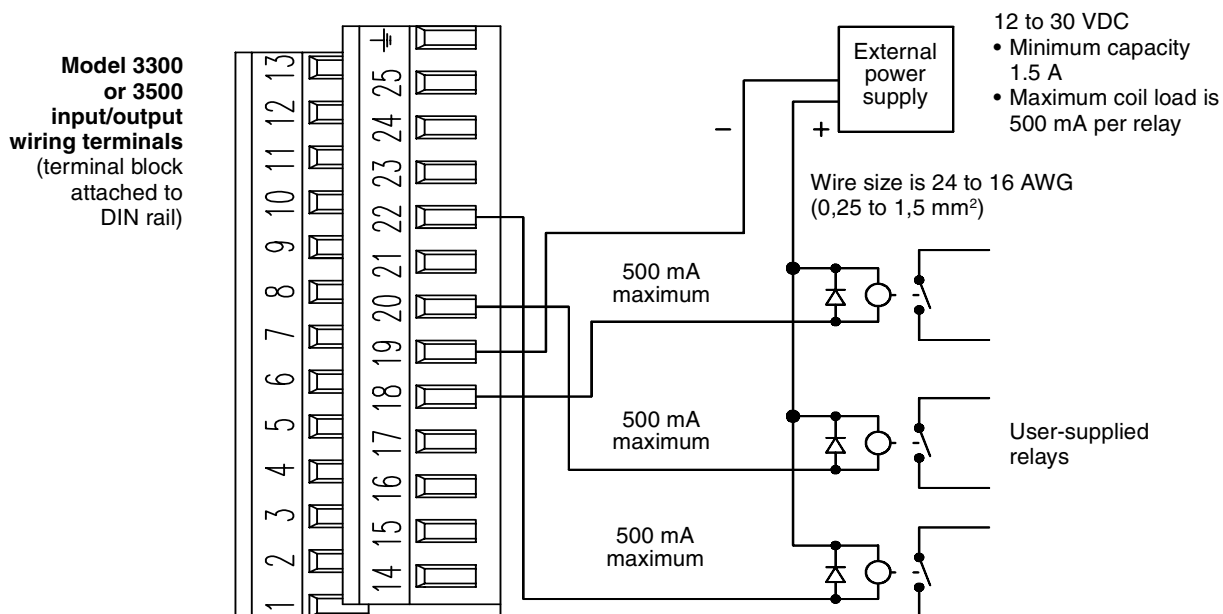
- Wire size is 24 to 16 AWG (0,25 to 1,5 mm<sup>2</sup>) for the Model 3300 or 3500; 22 to 16 AWG (0,34 to 1,5 mm<sup>2</sup>) for the Model 3350 or 3700.
- One relay, two relays, or all three relays may be connected.
- For a Model 3300 or 3500 with screw-type or solder-tail connectors, see **Figure 6-7**.
- For a Model 3300 or 3500 with I/O cables, see **Figure 6-8**.
- For a Model 3350 or 3700 see **Figure 6-9**.



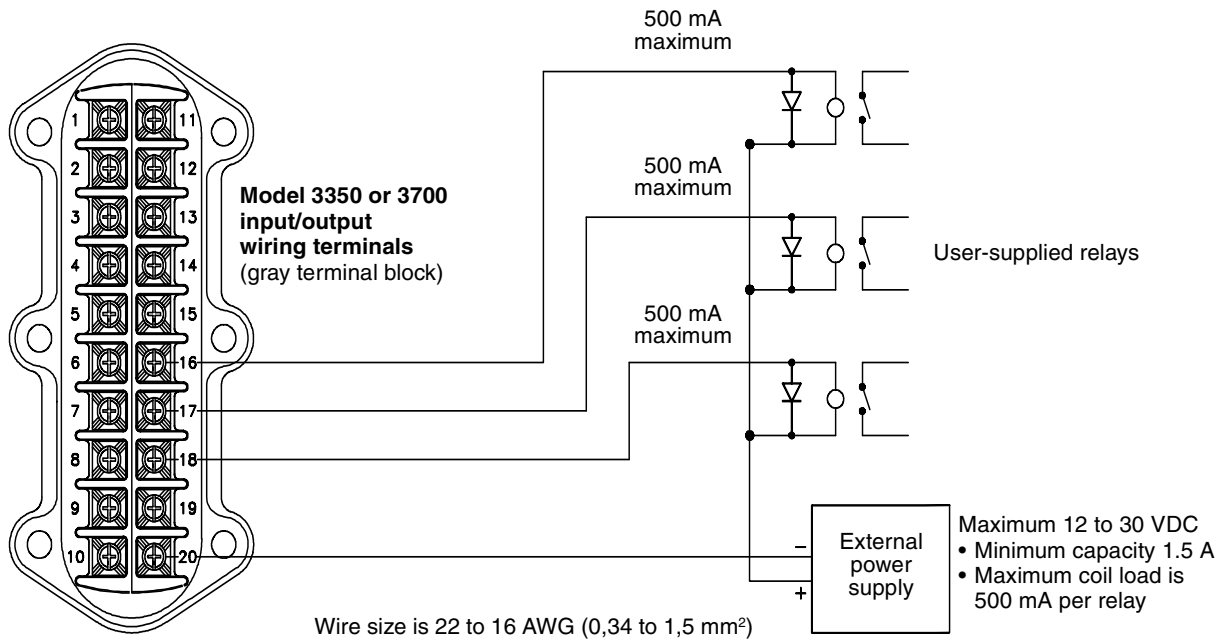
**Figure 6-7. Wiring for user-supplied relays to screw-type or solder-tail connector**



**Figure 6-8. Wiring for user-supplied relays to I/O cable**



**Figure 6-9. Wiring for user-supplied relays to Model 3350 or 3700**



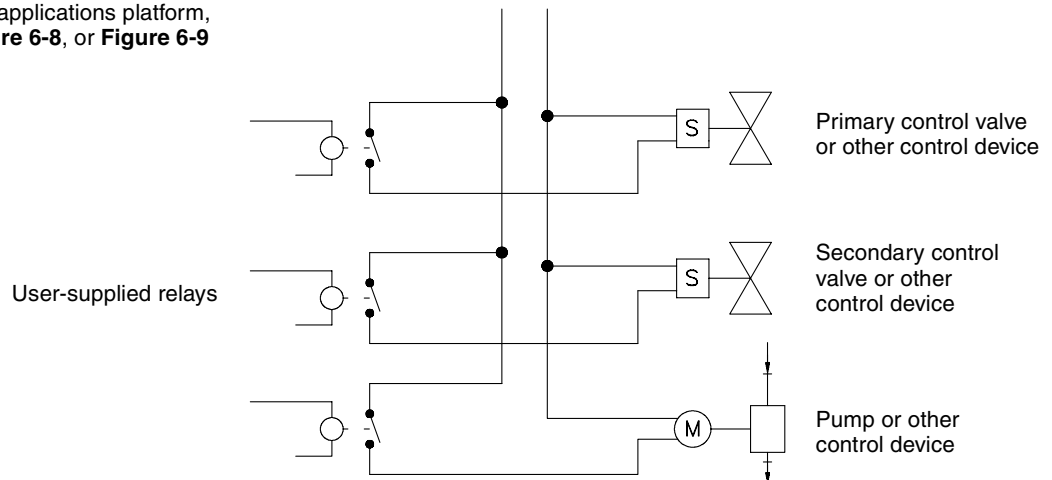
## Step 2 Connect wiring to control devices

To connect wiring from the relay wiring terminal block to the devices the relays will control, see **Figure 6-10**.

- The installation depends on the functions the relays will perform.
- **Figure 6-10** illustrates a typical wiring installation for a 2-stage batch application.

**Figure 6-10. Typical wiring diagram, 2-stage batch application**

To connect relays to applications platform, see **Figure 6-7**, **Figure 6-8**, or **Figure 6-9**



## 6.8 Discrete output configuration

The applications platform will not operate properly unless configuration tasks are performed in the proper sequence.

**⚠ CAUTION**

**Failure to perform configuration tasks in the proper sequence could result in an incomplete or flawed configuration, causing measurement error.**

To avoid measurement error, perform configuration tasks in the following sequence:

1. Configure system parameters
2. Configure inputs
3. Configure application parameters
4. Configure measurement parameters
5. Configure outputs
6. Configure digital communications

To configure the discrete outputs, follow these steps:

1. Configure system parameters. (See the *Series 3000 Detailed Setup Manual*.)
2. Configure inputs. (See the *Series 3000 Detailed Setup Manual*.)
3. Configure application parameters. (See the *Series 3000 Detailed Setup Manual*.)
4. Configure measurement parameters. (See the *Series 3000 Detailed Setup Manual*.)
5. Configure outputs.
  - a. Configure Discrete Output 1, Discrete Output 2, and Discrete Output 3 to operate from the appropriate power source. See **Table 6-1**.
  - b. Assign functions to outputs. (See the *Series 3000 Detailed Setup Manual*.)
6. Configure digital communications. (See the *Series 3000 Detailed Setup Manual*.)

**Table 6-1. Discrete output power options**

Power source	Default	Description
Internal	Internal	<ul style="list-style-type: none"> <li>• The circuit provides 24 volts when ON and 0 volts when OFF</li> <li>• The circuit is open when ON and closed when OFF</li> </ul>
External		<ul style="list-style-type: none"> <li>• The circuit provides 0 volts when ON and 24 volts when OFF</li> <li>• The circuit is open when OFF and closed when ON</li> </ul>



# 7

## Printer Setup

### 7.1 About this chapter

This chapter explains how to set up a printer for operation with the Series 3000 applications platform. The setup procedure includes the following steps:

1. Installing wiring from the applications platform to a user-supplied RS-485/RS-232-C serial converter, which connects to the printer
2. Configuring the printer setup
3. Performing a printer test

### Step 1 Connect wiring to the serial converter

#### Ordering or specifying a serial converter

Micro Motion has specified a serial converter for use with the applications platform. To order the converter, or for information about it, contact Micro Motion at any of the telephone numbers listed on the back cover of these instructions, and inquire about Custom Engineering Quotation number 7757. For a CE Mark-compliant converter, inquire about Custom Engineering Quotation number 7757B.

- RS-485 connection: 3-position terminal strip for twisted-pair wire, 22 to 24 AWG (0,25 to 0,34 mm<sup>2</sup>)
- RS-232-C connection: RJ11 to DB25 cable
- Voltage input range: Wall power supply, 9 VDC at 200 mA, or 12 VDC at 500 mA

To order the specified converter with a ticket printer, or for information about it, contact Micro Motion at any of the telephone numbers listed on the back cover of these instructions, and inquire about Custom Engineering Quotation number 6954D.

The ProLink<sup>®</sup> serial converter will not work with the applications platform. Since the ProLink PC Interface Adaptor (PCIA) box does not control the ready-to-send (RTS) line, communication between the applications platform and the printer cannot be initiated.

#### Wiring connections

Connect wiring from the application platform's RS-485 terminals to a user-supplied RS-485/RS-232-C serial converter, or a serial converter available through Custom Engineering Quotation 7757 or 7757B.

- Install a maximum of 4000 feet (1200 meters) of twisted-pair cable between the applications platform and the serial converter.
- Install shielded, twisted-pair wiring to pass through any area that might produce electromagnetic interference.
- **Table 7-1** lists RS-485 wiring terminals.
- For wiring connections from the Model 3300 or 3500 to the converter, see **Figure 7-1**.
- For wiring connections from the Model 3350 or 3700 to the converter, see **Figure 7-2**.

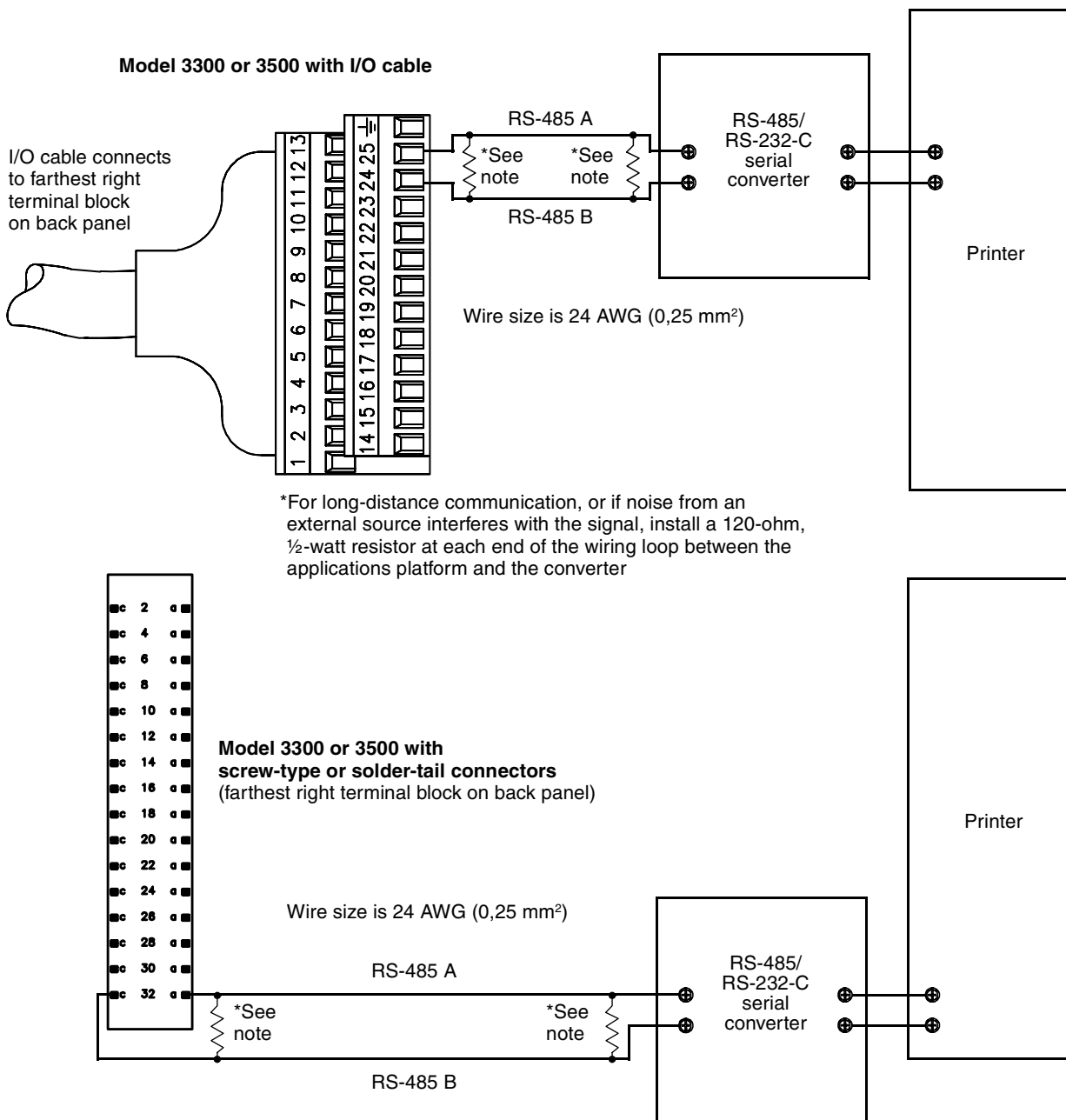
The applications platform has a label or a card that shows input/output wiring terminal designations. See **Figure 7-3**.

- For a Model 3300 or 3500 with screw-type or solder-tail connectors, the card is inserted into a sleeve on the top panel.
- For a Model 3300 or 3500 with I/O cable, the label is on the terminal block that is attached to a DIN rail.
- The label is on the back of the display cover on the Model 3350 or 3700.

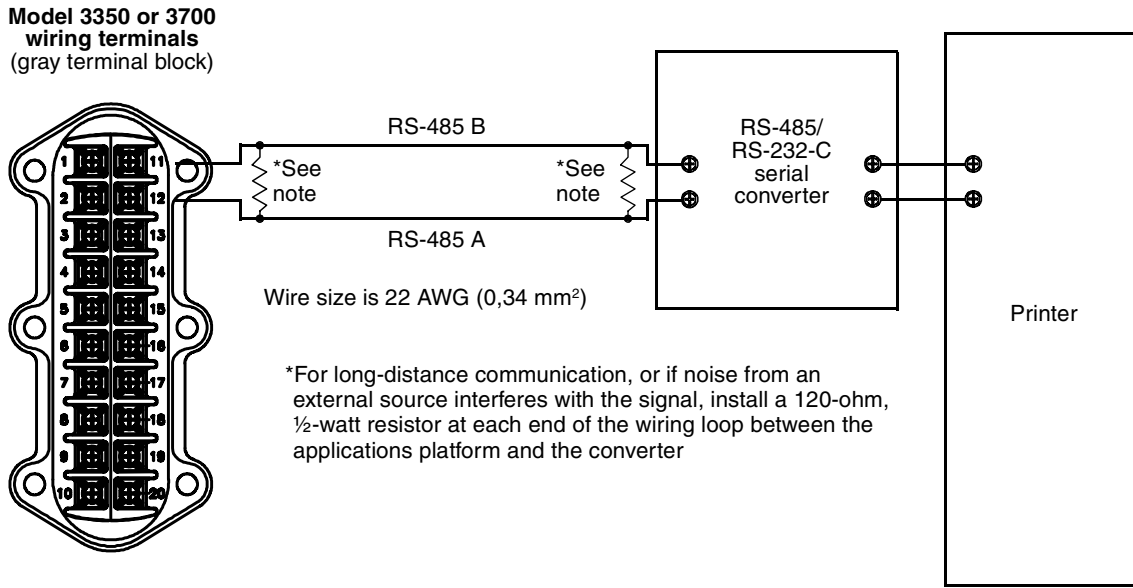
**Table 7-1. RS-485 wiring terminals**

Applications platform model	Terminal block location/description	RS-485 terminals	
		A	B
Model 3300 or 3500 with I/O cable	Terminal block installed on DIN rail	25	24
Model 3300 or 3500 with screw-type or solder-tail connectors	Back panel, farthest right terminal block	a 32	c 32
Model 3350 or 3700	Gray terminal block, increased safety wiring compartment	12	11

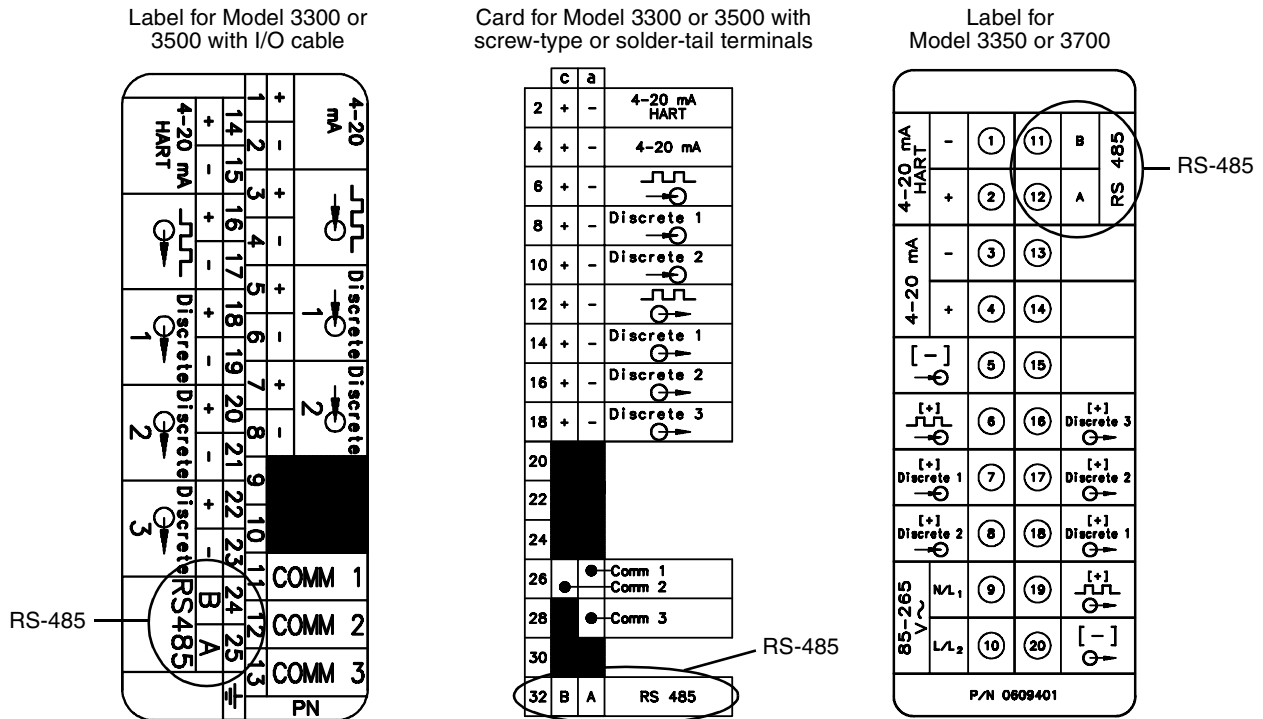
**Figure 7-1. Wiring connections: Model 3300 or 3500 to serial converter**



**Figure 7-2. Wiring connections: Model 3350 or 3700 to serial converter**



**Figure 7-3. Label and cards showing RS-485 terminal designations**





## Step 2 Configuring the printer setup

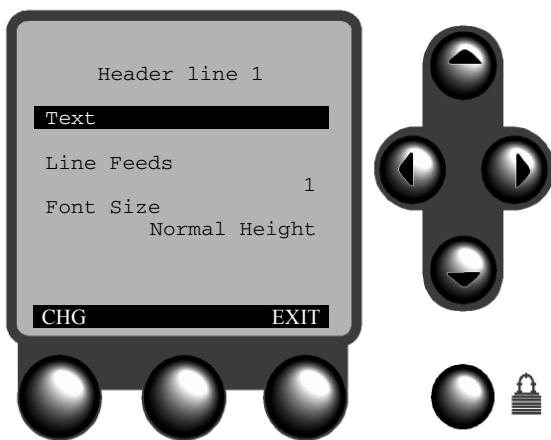
Configuring the printer setup includes the following procedures:

1. Configuring the header and footer
2. Configuring the other printer setup parameters

### Header and footer

#### Configuration

- └ Digital comm
  - └ Configure printer
    - └ Header line 1
    - └ Header line 2
    - └ Footer



To configure the header and footer:

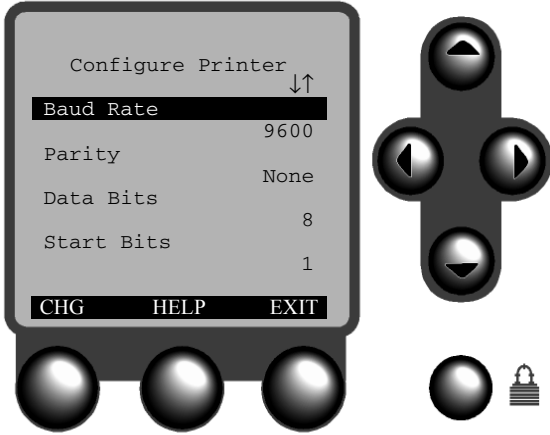
1. Press the security button on the display face.
2. Select Configuration.
3. Select Digital Comm.
4. Select Configure Printer.
5. Select Header Line 1, Header Line 2, or Footer.
6. Use the function keys and cursor control buttons to configure the parameters that are listed in **Table 7-2**.

**Table 7-2. Header and footer for printer ticket**

Variable	Default	Description
Text	Not applicable (no text)	Enter up to 21 characters of text for this line of the header or for the footer
Line feeds	1 line	<ul style="list-style-type: none"> <li>• Enter 1 or 2 if the font size is normal height</li> <li>• Enter 2 if the font size is double height</li> </ul>
Font size	Normal height	Select normal height or double height

**Other printer setup parameters**

- Configuration
  - └ Digital comm
    - └ Configure printer



To configure the printer setup:

1. Press the security button on the display face.
2. Select Configuration.
3. Select Digital Comm.
4. Select Configure Printer.
5. Use the function keys and cursor control buttons to configure the parameters that are listed in **Table 7-3**.

**Table 7-3. Printer setup variables**

Variable	Default	Description
Printer select	Epson TM-U295	Select Epson TM-U295, Digitec 6610A, or generic
Baud rate	9600 bps	Select 1200, 2400, 4800, or 9600 bps to match baud rate for the selected printer
Parity	None	Select none, odd, or even to match parity bits for the selected printer
Data bits	8 bits	Enter 7 or 8 data bits to match data bits for the selected printer
Start bits	1 bit	This variable is fixed at 1 start bit and cannot be changed
Stop bits	1 bit	Enter 1 or 2 stop bits to match stop bits for the selected printer

**Weights and measures ticket**

To configure a weights and measures ticket, refer to the *Series 3000 Detailed Setup Manual*.

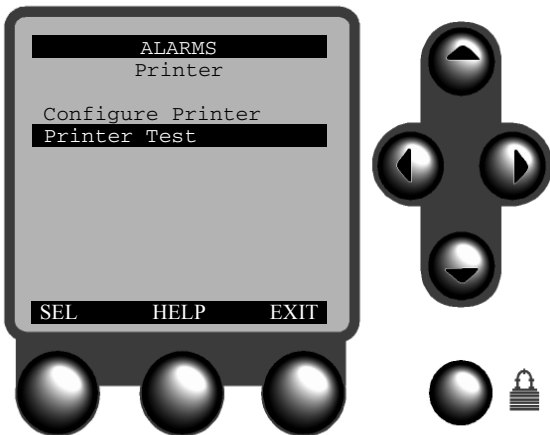
**Step 6 Perform the printer test**

To perform the printer test:

- a. After configuring the printer, press EXIT to return to the Printer menu.
- b. At the Printer menu, select Printer Test.

When the printer test is complete, the display reads, "Print test complete". If printing does not occur:

- Check wiring
- Make sure printer configuration settings match printer setup



# 8

## Startup

### 8.1 Startup and display test

At startup, the applications platform automatically tests its display. During display testing, all pixels darken for approximately five seconds. After the display test is completed:

1. The Micro Motion® logo appears.
2. An application list appears.
3. The applications platform enters the operations mode.

### Person Process Interface

**Figure 8-1** shows the Person Process Interface in a typical operations mode. Use the interface to:

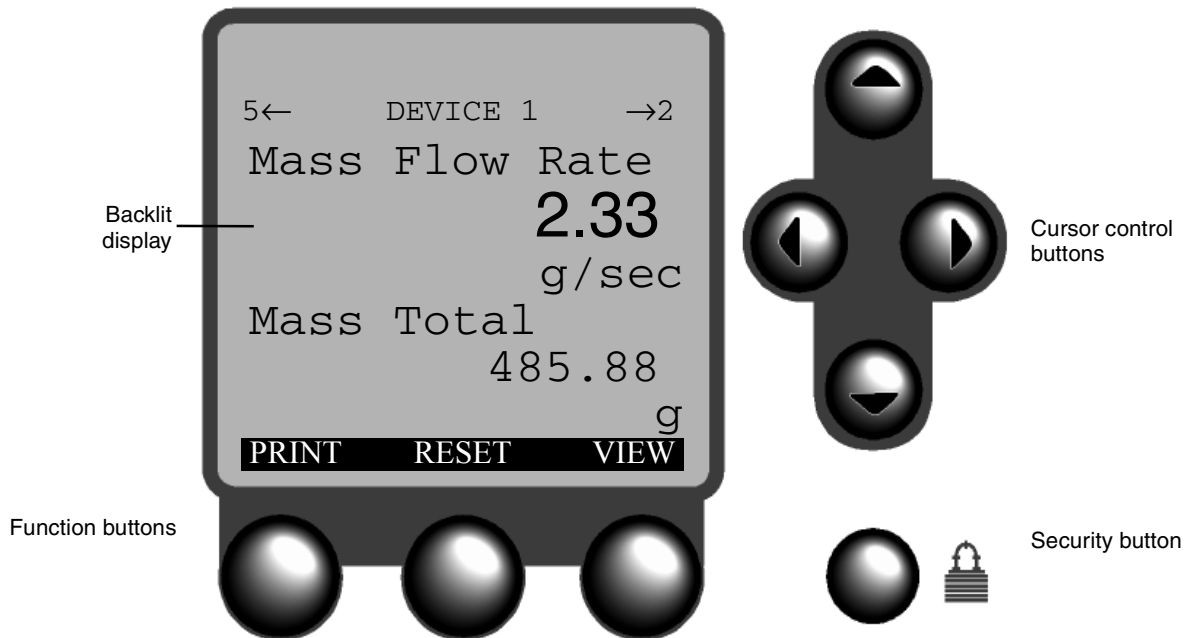
- Monitor and control the application
- Configure the application
- Perform maintenance and diagnostics tasks

### Security button

Press the security button to use the configuration mode. See **Figure 8-1**.

- If security is disabled, the Person Process Interface produces a menu of configuration and maintenance options.
- If security is enabled, you must enter a password.

**Figure 8-1. Person Process Interface in typical operations mode**



### Security bypass

Security can be bypassed if the user does not know the password or if the person who entered the password is not available.

To bypass security, rather than entering the password:

1. Press and hold the center function button.
2. Press the up arrow cursor control button.
3. Release the function and up arrow buttons.

### 8.2 Configuration mode

Use the configuration mode of the software to configure the application and perform maintenance tasks.

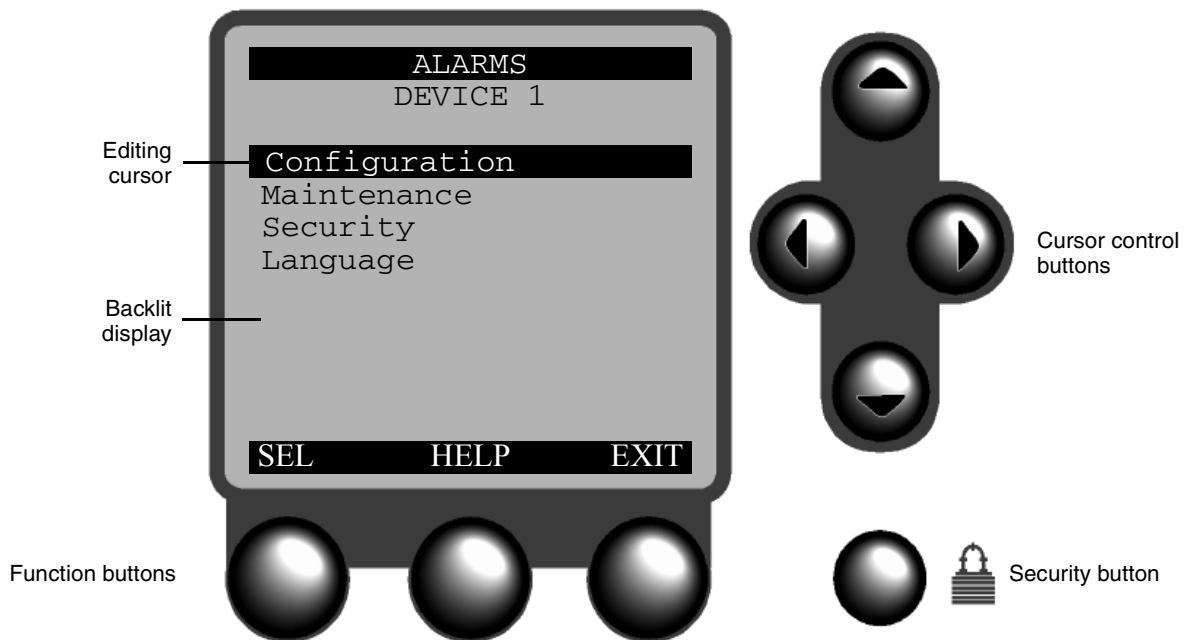
**⚠ CAUTION**

**During configuration outputs go to their configured fault settings, resulting in measurement error.**

For personal and system safety, set control devices for manual operation before accessing configuration menus.

**Figure 8-2** shows the Person Process Interface in a typical configuration mode. For information about using the configuration software, see the *Series 3000 Detailed Setup Manual*.

**Figure 8-2. Person Process Interface in typical configuration mode**



### 8.3 Sensor zero

If the applications platform is a Model 3500 or Model 3700 transmitter, a sensor zero calibration must be performed at initial startup.

Mechanical zero establishes flowmeter response to zero flow and sets a baseline for flow measurement.

#### CAUTION

**Failure to perform a sensor zero calibration at initial startup could cause the transmitter to produce inaccurate signals.**

To avoid inaccurate measurements, perform a sensor zero calibration before putting the transmitter into operation.

#### Preparing for sensor zero calibration

To prepare the flowmeter for sensor zero calibration:

1. Install the sensor according to the appropriate sensor instruction manual.
2. Apply power to the transmitter, then allow it to warm up for at least 30 minutes.
3. Run the process fluid to be measured through the sensor until the sensor temperature approximates the normal process operating temperature.
4. Close the shutoff valve downstream from the sensor.
5. Fill the sensor completely with process fluid under normal process conditions of temperature, density, pressure, etc., and ensure zero flow through the sensor.
6. **Make sure flow through the sensor is completely stopped.**

#### CAUTION

**Flow through the sensor during sensor zero calibration will result in an inaccurate zero setting.**

Make sure fluid flow through the sensor is **completely** stopped during sensor zero calibration.

### Performing the sensor zero calibration

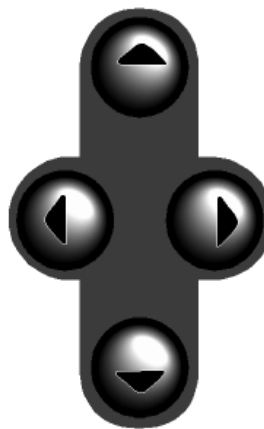
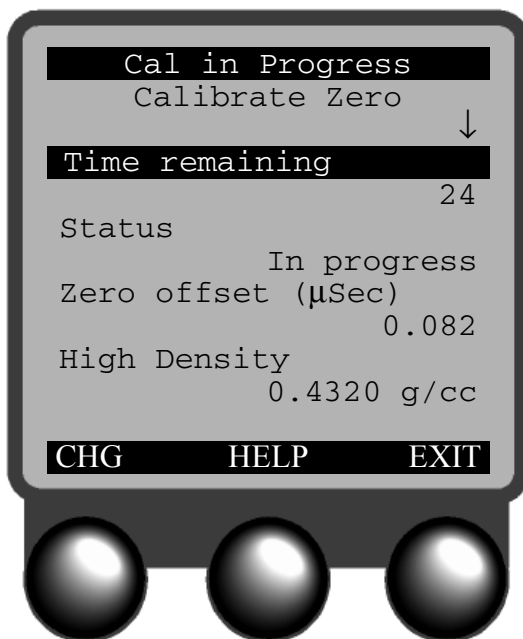
To perform the sensor zero calibration, refer to **Figure 8-3** and follow these steps:

1. Press the security button to access the main menu.
2. At the main menu, select Maintenance.
3. At the Maintenance menu, select Calibration.
4. At the Calibration menu, select Sensor Zero.
5. At the Sensor Zero menu, select Calibrate Zero, then press CHG.
  - To end the sensor zero before its completion, cycle power to the transmitter.
  - Sensor zero requires anywhere from 20 seconds to 2½ minutes (150 seconds), depending on the sensor model and the density of the process fluid.

After the calibration is complete, the Calibrate Zero screen displays the result, the zero offset in microseconds, the high density, and the low density.

- If the calibration is successful, the message "Calibration Complete" appears on the screen. Press ACK to acknowledge the alarm, then press EXIT to exit the Calibrate Zero screen.
- If the calibration is not successful, the message "Calibration Failure" appears on the screen.

**Figure 8-3. Calibrate Zero screen**



To perform the sensor zero calibration, follow these steps:

1. Press the security button.
2. Select Maintenance.
3. Select Calibration.
4. Select Sensor Zero.
5. Select Calibrate Zero, then press CHG.



Security button

**Diagnosing sensor zero failure**

If the Calibrate Zero screen reads "Calibration Failure," the sensor zero calibration was not successfully completed. "Calibration Failure" could indicate:

- Flow of fluid during the sensor zero calibration;
- Partially empty flow tubes; or
- An improperly mounted sensor.

To clear a sensor zero failure, re-zero after correcting the problem, or abort the procedure by cycling power to the transmitter.

**8.4 Fault outputs**

Outputs go to fault levels if a fault is detected. The applications platform also produces fault outputs while the user is performing configuration or diagnostics tasks. See **Table 8-1**.

**Table 8-1. Fault outputs produced during maintenance**

Software mode	Output levels
Configuration	Fault level
Diagnostics	Fault level
Calibration	Active (outputs indicate value of process variable during calibration)

The applications platform can be configured to produce downscale, upscale, last measured value, or internal zero fault outputs. See **Table 8-2**. The default configuration for fault outputs is downscale.

**Table 8-2. Fault output levels**

Fault limit	Fault value
Downscale	<ul style="list-style-type: none"> <li>• Milliamp outputs can be configured from 1.0 to 3.6 mA for milliamp outputs; default is 3.6 mA</li> <li>• Frequency output goes to 0 Hz</li> </ul>
Upscale	<ul style="list-style-type: none"> <li>• Milliamp outputs can be configured from 21.0 to 24.0 mA; default is 22.0 mA</li> <li>• Frequency output goes to 15,000 Hz</li> </ul>
Last measured value	Outputs hold at mA value or frequency that represents the last measured value for the process variable indicated by the output
Internal zero	<ul style="list-style-type: none"> <li>• Milliamp outputs go to mA value that represents 0.0 for the process variable indicated by the output</li> <li>• Frequency output goes to 0 Hz</li> </ul>

## 8.5 Alarm messages

The applications platform produces alarm messages.

The applications platform can produce any of the following types of alarm messages:


- Operational alarm messages
- Transmitter failure messages
- Process overrange messages
- Sensor error messages
- Slug flow and output saturation messages
- Informational messages

For more information about alarm messages, see the *Series 3000 Detailed Setup Manual*.

## 8.6 Repair and substitution of components

The applications platform does not contain any parts that can be repaired by the user. If the applications platform requires repair:

- Fill out the appropriate decontamination statement.
- Return the applications platform and decontamination statement to Micro Motion.

 <b>WARNING</b>
<p><b>Explosion Hazard.</b></p> <p>Do not disconnect or remove equipment connections unless power has been turned off or the area is known to be non-hazardous.</p> <p>Substitution of components may impair suitability for Class I, Division 2.</p>

## 8.7 Customer service

For customer service, phone the Micro Motion Customer Service Department. Telephone numbers are listed on the title page of this manual.



# Appendix A

# Specifications

## Model 3300

The Model 3300 Application Peripheral provides measurement and control functions based on input from external devices. The Model 3300 can run up to three applications simultaneously.

### Housings

#### Rack-mount

- 19-inch (486,2 mm) rack-mount housing meets DIN standard 41494 and IEC 297-3
- Front panel is rated IP40

#### Panel-mount

- With bezel mounting kit, fits into same cutout as Micro Motion peripherals
- Bezel is larger than bezel on Micro Motion DRT, FMS-3, DMS, NFC, or NOC peripherals
- Front panel with bezel is rated NEMA 4X (IP65)

#### Optional NEMA 4X (IP65) housings

NEMA 4X (IP65) housing with cutout

### Person Process Interface

#### Display

- Backlit LCD, 128 x 128 pixel, bit map
- Adjustable contrast
- Non-glare, chemical-resistant acrylic lens

#### Keypad membrane switch

- Large push-buttons with tactile feedback
- Software-defined function keys
- Chemical-resistant polyester

### Electrical connections

#### Rack-mount

Input and output connections

- Type D connectors per DIN standard 41612 (IEC 603-2)
- Available as solder tails (standard) or screw terminals (optional)
- Screw terminals accept 24 AWG (0,25 mm<sup>2</sup>) to 16 AWG (1,5 mm<sup>2</sup>) wires

## Specifications *continued*

### Power connection

- Screw terminals are fixed to rack chassis
- Ground makes first and breaks last
- Terminals accept 18 AWG (0,75 mm<sup>2</sup>) to 14 AWG (2,5 mm<sup>2</sup>) wires

## Panel-mount

### Input and output connections

- Screw terminals (standard) or I/O cable with remote DIN-rail-mount screw terminals (optional)
- Remote terminals attach to any of four rail types. I/O cable is available in lengths of 2, 5, and 10 feet (0,6, 1,5, and 3 meters)
- Terminals accept 24 AWG (0,25 mm<sup>2</sup>) to 16 AWG (1,5 mm<sup>2</sup>) wires

Power connection screw terminals accept 18 AWG (0,75 mm<sup>2</sup>) to 14 AWG (2,5 mm<sup>2</sup>) wires

## Non-intrinsically safe input signals

### Frequency/pulse input

#### One 2-wire frequency/pulse input

- Frequency range 0-20,000 Hz
- Minimum pulse width 25  $\mu$ sec
- Power: Sourcing or sinking
- Voltage: 0-0.8 VDC low state  
3-30 VDC high state
- Current: Nominal 5 mA pull-up

### Discrete inputs

#### Two discrete, momentary inputs

- Pulse width 0.15  $\mu$ sec minimum
- Voltage: 0-0.8 VDC low state  
3-30 VDC high state  
dry contacts

## Non-intrinsically safe output signals

### Milliampere outputs

#### Two active 4-20 mA outputs

- Isolated to  $\pm$ 50 VDC from all other outputs and earth ground
- Maximum load limit, 1000 ohms
- Output is linear with process from 3.8 to 20.5 mA, per NAMUR NE43 (June 1994)

### Discrete outputs

#### Three discrete outputs

- Configurable for the application
- Power: Active, polarity software configurable (see **Table 6-1**)
- Voltage: 24 VDC nominal
- Current: Sourcing at 5.6 mA when  $V_{out} = 3$  VDC  
Sinking up to 500 mA at 30 VDC maximum

## Specifications *continued*

### Frequency/pulse output

- One 2-wire frequency/pulse output
- Output is linear with flow rate to 12,500 Hz
  - Configurable unit of measure
  - Scalable to 10,000 Hz
  - Pulse width: 50% duty cycle above 500 Hz  
Configurable for frequencies below 500 Hz
  - Power: Active or passive, software selectable
  - Voltage: 24 VDC nominal, active  
20 VDC applied maximum, passive
  - Current: Sourcing, 10 mA at 3 VDC, active  
Sinking, 500 mA, active or passive

### Fault output

- When a fault is detected, outputs go to configured states. User can select high, low, last measured value, or internal zero. Milliampere outputs conform to NAMUR NE43 (June 1994).
- High output limits can be configured from 21 to 24 mA for milliampere; 15,000 Hz for frequency
  - Low output limits can be configured from 1 to 3.6 mA for milliampere; 0 Hz for frequency
  - Last measured value is the last output for the process variable
  - Internal zero drives the milliampere and frequency outputs for process variables to zero values

### Digital communications

- One RS-485 port (standard)
- Send only
  - Requires external adaptor (not included) for conversion to RS-232

### Power supply options

#### 85 to 250 VAC (85 to 265 VAC with CENELEC approval)

- 50/60 Hz, 15 VA
- 0.25A max at 85 VAC, 0.12 A max at 265 VAC
- IEC 127-3/4 fuse, 0.63 A time-delay
- Complies with low-voltage directive 73/23/EEC per IEC 1010-1 with Amendment 2
- Installation (Overvoltage) Category II, Pollution Degree 2

#### 18 to 30 VDC

- 7 watts typical, 14 watts maximum
- IEC 127-3/4 fuse, 1.6 A time-delay

### Environmental limits

#### Ambient temperature limits

- Operating: -4 to 140°F (-20 to 60°C)
- Storage: -40 to 158°F (-40 to 70°C)
- Some darkening of display may occur above 131°F (55°C)
- Display responsiveness decreases below -4°F (-20°C)

#### Humidity limits

5 to 95% relative humidity, non-condensing at 140°F (60°C)

## Specifications *continued*

### Vibration limits

Per IEC 68-2-6 at 1.0 g, 15 to 2000 Hz, 50 sweep cycles

## Environmental effects

### EMI effects

- Meets EMC directive 89/336/EEC per EN 50081-2 (August 1993) and EN 50082-2 (March 1995)
- Conforms to NAMUR NE21 (June 1997)

### Ambient temperature effect

On analog outputs  $\pm 0.005\%$  of span per °C

## Hazardous area classifications

### UL and CSA

Class I, Div. 2, Groups A, B, C, D when installed in a suitable enclosure.

### ATEX

Zone 2, complying with ATEX Directive (94/9/EC) for group II category 3G, according to CENELEC standard prEN 50021:1998 and marked as EEx nVL IIC T4.

## Performance specifications

See the product data sheet for your sensor.

## Cleaning instructions

To clean the Model 3300 application peripheral, use a clean, dry cloth or dry air.

## Model 3350

The Model 3350 Application Peripheral provides measurement and control functions based on input from external sources. The field-mount enclosure meets area classifications worldwide. The Model 3350 can run up to three applications simultaneously.

### Compartmentalized housing

- Compartment with threaded cover contains electronics
- Non-intrinsically safe compartment contains input and output terminals
- Intrinsically safe compartment contains Person Process Interface and optional input and output terminals
- Mounting bracket and Person Process Interface rotate to allow mounting in four different orientations
- NEMA 4X (IP67)

### Person Process Interface

#### Display

- Backlit LCD, 128 x 128 pixel, bit map
- Adjustable contrast
- Non-glare, tempered glass lens
- Suitable for hazardous area installation

#### Keypad membrane switch

- Large push-buttons with tactile feedback
- Software-defined function keys
- Chemical-resistant polyester

### Electrical connections

Two color-coded wiring compartments

- Compartment with intrinsically safe terminal block has two 3/4-inch NPT or M20x1.5 conduit openings
- Compartment with non-intrinsically safe terminal block has three 3/4-inch NPT or M20x1.5 conduit openings
- Input and output screw terminals accept 22 AWG (0,34 mm<sup>2</sup>) to 16 AWG (1,5 mm<sup>2</sup>) wires
- Power screw terminals accept 18 AWG (0,75 mm<sup>2</sup>) to 12 AWG (4,0 mm<sup>2</sup>) wires

### Non-intrinsically safe input signals

#### Frequency/pulse input

One 2-wire frequency/pulse input

- Frequency range 0-20,000 Hz
- Minimum pulse width 25 µsec
- Power: Sourcing or sinking
- Voltage: 0-0.8 VDC low state  
3-30 VDC high state
- Current: Nominal 5 mA pull-up

## Specifications *continued*

### Discrete inputs

- Two discrete, momentary inputs
- Pulse width 0.15  $\mu$ sec minimum
  - Voltage: 0-0.8 VDC low state  
3-30 VDC high state  
dry contacts

### Non-intrinsically safe output signals

#### Milliampere outputs

- Two active 4-20 mA outputs
- Isolated to  $\pm 50$  VDC from all other outputs and earth ground
  - Maximum load limit, 1000 ohms
  - Output is linear with process from 3.8 to 20.5 mA, per NAMUR NE43 (June 1994)

#### Discrete outputs

- Three discrete outputs
- Configurable for the application
  - Power: Active, polarity software configurable (see **Table 6-1**)
  - Voltage: 24 VDC nominal
  - Current: Sourcing at 5.6 mA when  $V_{out} = 3$  VDC  
Sinking up to 500 mA at 30 VDC maximum

#### Frequency/pulse output

- One 2-wire frequency/pulse output
- Output is linear with flow rate to 12,500 Hz
  - Configurable unit of measure
  - Scalable to 10,000 Hz
  - Pulse width: 50% duty cycle above 500 Hz  
Configurable for frequencies below 500 Hz
  - Power: Active or passive, software selectable
  - Voltage: 24 VDC nominal, active  
20 VDC applied maximum, passive
  - Current: Sourcing, 10 mA at 3 VDC, active  
Sinking, 500 mA, active or passive

#### Fault output

- When a fault is detected, outputs go to configured states. User can select high, low, last measured value, or internal zero. Milliampere outputs conform to NAMUR NE43 (June 1994).
- High output limits can be configured from 21 to 24 mA for milliampere; 15,000 Hz for frequency
  - Low output limits can be configured from 1 to 3.6 mA for milliampere; 0 Hz for frequency
  - Last measured value is the last output for the process variable
  - Internal zero drives the milliampere and frequency outputs for process variables to zero values

#### Digital communications

- One RS-485 port (standard)
- Send only
  - Requires external adaptor (not included) for conversion to RS-232

## Specifications *continued*

### Power supply options

#### **85 to 250 VAC (85 to 265 VAC with GENELEC approval)**

- 50/60 Hz, 30 VA
- 0.33A max at 85 VAC, 0.15 A max at 265 VAC
- IEC 127-3/4 fuse, 0.63 A time-delay
- Complies with low-voltage directive 73/23/EEC per IEC 1010-1 with Amendment 2
- Installation (Overvoltage) Category II, Pollution Degree 2

#### **18 to 30 VDC**

- 18 watts typical, 25 watts maximum
- IEC 127-3/4 fuse, 1.6 A time-delay

### Environmental limits

#### **Ambient temperature limits**

- Operating: -4 to 140°F (-20 to 60°C)
- Storage: -40 to 158°F (-40 to 70°C)
- Some darkening of display may occur above 131°F (55°C)
- Display responsiveness decreases below -4°F (-20°C)

#### **Humidity limits**

5 to 95% relative humidity, non-condensing at 140°F (60°C)

#### **Vibration limits**

Per IEC 68-2-6 at 1.0 g, 15 to 2000 Hz, 50 sweep cycles

### Environmental effects

#### **EMI effects**

- Meets EMC directive 89/336/EEC per EN 50081-2 (August 1993) and EN 50082-2 (March 1995)
- Conforms to NAMUR NE21 (June 1997)

#### **Ambient temperature effect**

On analog outputs  $\pm 0.005\%$  of span per °C

### Hazardous area installations

#### **UL and CSA**

Class I, Div. 2, Groups A, B, C, and D. Provides nonincendive sensor outputs for use in Class I, Div. 2, Groups A, B, C, D, or intrinsically safe sensor outputs for use in Class I, Div. 1, Groups C and D; Class II, Div. 1, Groups E, F, and G.

#### **ATEX**

Zone 1, complying with ATEX Directive (94/9/EC) for group II category 2G and marked as EEx de [ib] IIB/IIC T4.

**Specifications** *continued*

**Performance specifications**

See the product data sheet for your sensor.

**Cleaning instructions**

To clean the Model 3350 application peripheral, use a clean, damp cloth.

**⚠ WARNING**

**Using a dry cloth to clean the display cover of the Model 3350 or 3700 can cause static discharge, which could result in an explosion in an explosive atmosphere.**

To prevent an explosion, use a clean, damp cloth to clean the display cover of the Model 3350 application peripheral or Model 3700 transmitter in an explosive atmosphere.



## Model 3500

The Model 3500 Transmitter uses Micro Motion Coriolis technology for flow and density measurement to provide application solutions capabilities. The Model 3500 can run up to three applications simultaneously.

### Housings

#### DIN rack

- 19-inch (486,2 mm) rack-mount meets DIN standard 41494 and IEC 297-3
- Front panel is rated IP40

#### Panel mount

- With bezel mounting kit, fits into same cutout as Micro Motion peripherals
- Bezel is larger than bezel on Micro Motion DRT, FMS-3, DMS, NFC, or NOC peripherals
- Front panel with bezel is rated NEMA 4X (IP65)

#### Optional NEMA 4X (IP65) housings

NEMA 4X (IP65) housing with cutout

### Person Process Interface

#### Display

- Backlit LCD, 128 x 128 pixel, bit map
- Adjustable contrast
- Non-glare, chemical-resistant acrylic lens

#### Keypad Membrane Switch

- Large push-buttons with tactile feedback
- Software-defined function keys
- Chemical-resistant polyester

### Electrical connections

#### Rack-mount

Input and output connections

- Type D connectors per DIN standard 41612 (IEC 603-2)
- Available as solder tails (standard) or screw terminals (optional)
- Screw terminals accept 24 AWG (0,25 mm<sup>2</sup>) to 16 AWG (1,5 mm<sup>2</sup>) wires

Power connection

- Screw terminals are fixed to rack chassis
- Ground makes first and breaks last
- Terminals accept 18 AWG (0,75 mm<sup>2</sup>) to 14 AWG (2,5 mm<sup>2</sup>) wires

## Specifications *continued*

### Panel-mount

Input and output connections

- Screw terminals (standard) or I/O cable with remote DIN-rail-mount screw terminals (optional)
- Remote terminals attach to any of four rail types. I/O cable is available in lengths of 2, 5, and 10 feet (0,6, 1,5, and 3 meters)
- Terminals accept 24 AWG (0,25 mm<sup>2</sup>) to 16 AWG (1,5 mm<sup>2</sup>) wires

Power connection screw terminals accept 18 AWG (0,75 mm<sup>2</sup>) to 14 AWG (2,5 mm<sup>2</sup>) wires

### Intrinsically safe input signals

One 9-wire Coriolis sensor signal input with ground (standard)

### Non-intrinsically safe input signals

#### Frequency/pulse input

One 2-wire frequency/pulse input

- Frequency range 0-20,000 Hz
- Minimum pulse width 25  $\mu$ sec
- Power: Sourcing or sinking
- Voltage: 0-0.8 VDC low state  
3-30 VDC high state
- Current: Nominal 5 mA pull-up

#### Discrete inputs

Two discrete, momentary inputs

- Pulse width 0.15  $\mu$ sec minimum
- Voltage: 0-0.8 VDC low state  
3-30 VDC high state  
dry contacts

### Non-intrinsically safe output signals

#### Milliampere outputs

Two active 4-20 mA outputs

- Isolated to  $\pm$ 50 VDC from all other outputs and earth ground
- Maximum load limit, 1000 ohms
- Output is linear with process from 3.8 to 20.5 mA, per NAMUR NE43 (June 1994)

#### Discrete outputs

Three discrete outputs

- Configurable for the application
- Power: Active, polarity software configurable (see **Table 6-1**)
- Voltage: 24 VDC nominal
- Current: Sourcing at 5.6 mA when  $V_{out} = 3$  VCD  
Sinking up to 500 mA at 30 VDC maximum

## Specifications *continued*

### Frequency/pulse output

- One 2-wire frequency/pulse output
- Output is linear with flow rate to 12,500 Hz
  - Configurable unit of measure
  - Scalable to 10,000 Hz
  - Pulse width: 50% duty cycle above 500 Hz  
Configurable for frequencies below 500 Hz
  - Power: Active or passive, software selectable
  - Voltage: 24 VDC nominal, active  
20 VDC applied maximum, passive
  - Current: Sourcing, 10 mA at 3 VDC, active  
Sinking, 500 mA, active or passive

### Fault output

- When a fault is detected, outputs go to configured states. User can select high, low, last measured value, or internal zero. Milliampere outputs conform to NAMUR NE43 (June 1994).
- High output limits can be configured from 21 to 24 mA for milliampere; 15,000 Hz for frequency
  - Low output limits can be configured from 1 to 3.6 mA for milliampere; 0 Hz for frequency
  - Last measured value is the last output for the process variable
  - Internal zero drives the milliampere and frequency outputs for process variables to zero values

### Digital communications

- One RS-485 port (standard)
- Send only
  - Requires external adaptor (not included) for conversion to RS-232

### Power supply options

#### 85 to 250 VAC (85 to 265 VAC with CENELEC approval)

- 50/60 Hz, 30 VA
- 0.33A max at 85 VAC, 0.15 A max at 265 VAC
- IEC 127-3/4 fuse, 0.63 A time-delay
- Complies with low-voltage directive 73/23/EEC per IEC 1010-1 with Amendment 2
- Installation (Overvoltage) Category II, Pollution Degree 2

#### 18 to 30 VDC

- 18 watts typical, 25 watts maximum
- IEC 127-3/4 fuse, 1.6 A time-delay

### Environmental limits

#### Ambient temperature limits

- Operating: -4 to 140°F (-20 to 60°C)
- Storage: -40 to 158°F (-40 to 70°C)
- Some darkening of display may occur above 131°F (55°C)
- Display responsiveness decreases below -4°F (-20°C)

#### Humidity limits

5 to 95% relative humidity, non-condensing at 140°F (60°C)

## Specifications *continued*

### Vibration limits

Per IEC 68-2-6 at 1.0 g, 15 to 2000 Hz, 50 sweep cycles

### Environmental effects

#### EMI effects

- Meets EMC directive 89/336/EEC per EN 61326 Industrial
- Conforms to NAMUR NE21 (June 1997)

#### Ambient temperature effect

On analog outputs  $\pm 0.005\%$  of span per °C

### Hazardous area classifications

#### UL and CSA

Class I, Div. 2, Groups A, B, C, D when installed in a suitable enclosure. Provides nonincendive sensor outputs for use in Class I, Div. 2, Groups A, B, C, D, or intrinsically safe sensor outputs for use in Class I, Div. 1, Groups C and D; Class II, Div. 1, Groups E, F, and G.

#### ATEX

Safe area only. Can be connected to a sensor in ATEX Zone 1 area if sensor is marked as [EEx ib] IIB/IIC.

### Performance specifications

See the product data sheet for your sensor.

### Cleaning instructions

To clean the Model 3500 transmitter, use a clean, dry cloth or dry air.

## Model 3700

The Model 3700 Transmitter uses Micro Motion Coriolis technology for flow and density measurement to provide application solutions capabilities. The field-mount enclosure meets area classifications worldwide. The Model 3700 can run up to three applications simultaneously.

### Compartmentalized housing

- Compartment with threaded cover contains electronics
- Non-intrinsically safe compartment contains input and output terminals
- Intrinsically safe compartment contains Person Process Interface, sensor, and optional input and output terminals
- Mounting bracket and Person Process Interface rotate to allow mounting in four different orientations
- NEMA 4X (IP67)

### Person Process Interface

#### Display

- Backlit LCD, 128 x 128 pixel, bit map
- Adjustable contrast
- Non-glare, tempered glass lens
- Suitable for hazardous area installation

#### Keypad membrane switch

- Large push-buttons with tactile feedback
- Software-defined function keys
- Chemical-resistant polyester

### Electrical connections

Two color-coded wiring compartments

- Compartment with intrinsically safe terminal block has two 3/4-inch NPT or M20x1.5 conduit openings
- Compartment with non-intrinsically safe terminal block has three 3/4-inch NPT or M20x1.5 conduit openings
- Input and output screw terminals accept 22 AWG (0,34 mm<sup>2</sup>) to 16 AWG (1,5 mm<sup>2</sup>) wires
- Power screw terminals accept 18 AWG (0,75 mm<sup>2</sup>) to 12 AWG (4,0 mm<sup>2</sup>) wires

### Intrinsically safe input signals

One 9-wire Coriolis sensor signal input with ground (standard)

## Specifications *continued*

### Non-intrinsically safe input signals

#### Frequency/pulse input

- One 2-wire frequency/pulse input
- Frequency range 0-20,000 Hz
  - Minimum pulse width 25  $\mu$ sec
  - Power: Sourcing or sinking
  - Voltage: 0-0.8 VDC low state  
3-30 VDC high state
  - Current: Nominal 5 mA pull-up

#### Discrete inputs

- Two discrete, momentary inputs
- Pulse width 0.15  $\mu$ sec minimum
  - Voltage: 0-0.8 VDC low state  
3-30 VDC high state  
dry contacts

### Non-intrinsically safe output signals

#### Milliampere outputs

- Two active 4-20 mA outputs
- Isolated to  $\pm 50$  VDC from all other outputs and earth ground
  - Maximum load limit, 1000 ohms
  - Output is linear with process from 3.8 to 20.5 mA, per NAMUR NE43 (June 1994)

#### Discrete outputs

- Three discrete outputs
- Configurable for the application
  - Power: Active, polarity software configurable (see **Table 6-1**)
  - Voltage: 24 VDC nominal
  - Current: Sourcing at 5.6 mA when  $V_{out} = 3$  VDC  
Sinking up to 500 mA at 30 VDC maximum

#### Frequency/pulse output

- One 2-wire frequency/pulse output
- Output is linear with flow rate to 12,500 Hz
  - Configurable unit of measure
  - Scalable to 10,000 Hz
  - Pulse width: 50% duty cycle above 500 Hz  
Configurable for frequencies below 500 Hz
  - Power: Active or passive, software selectable
  - Voltage: 24 VDC nominal, active  
20 VDC applied maximum, passive
  - Current: Sourcing, 10 mA at 3 VDC, active  
Sinking, 500 mA, active or passive

## Specifications *continued*

### Fault output

When a fault is detected, outputs go to configured states. User can select high, low, last measured value, or internal zero. Milliampere outputs conform to NAMUR NE43 (June 1994).

- High output limits can be configured from 21 to 24 mA for milliampere; 15,000 Hz for frequency
- Low output limits can be configured from 1 to 3.6 mA for milliampere; 0 Hz for frequency
- Last measured value is the last output for the process variable
- Internal zero drives the milliampere and frequency outputs for process variables to zero values

### Digital communications

One RS-485 port (standard)

- Send only
- Requires external adaptor (not included) for conversion to RS-232

### Power supply options

#### 85 to 250 VAC (85 to 265 VAC with CENELEC approval)

- 50/60 Hz, 30 VA
- 0.33A max at 85 VAC, 0.15 A max at 265 VAC
- IEC 127-3/4 fuse, 0.63 A time-delay
- Complies with low-voltage directive 73/23/EEC per IEC 1010-1 with Amendment 2
- Installation (Overvoltage) Category II, Pollution Degree 2

#### 18 to 30 VDC

- 18 watts typical, 25 watts maximum
- IEC 127-3/4 fuse, 1.6 A time-delay

### Environmental limits

#### Ambient temperature limits

- Operating: -4 to 140°F (-20 to 60°C)
- Storage: -40 to 158°F (-40 to 70°C)
- Some darkening of display may occur above 131°F (55°C)
- Display responsiveness decreases below -4°F (-20°C)

#### Humidity limits

5 to 95% relative humidity, non-condensing at 140°F (60°C)

#### Vibration limits

Per IEC 68-2-6 at 1.0 g, 15 to 2000 Hz, 50 sweep cycles

## Specifications *continued*

### Environmental effects

#### EMI effects

- Meets EMC directive 89/336/EEC per EN 61326 Industrial
- Conforms to NAMUR NE21 (June 1997)

#### Ambient temperature effect

On analog outputs  $\pm 0.005\%$  of span per °C

### Hazardous area installations

#### UL and CSA

Class I, Div. 2, Groups A, B, C, and D. Provides nonincendive sensor outputs for use in Class I, Div. 2, Groups A, B, C, D, or intrinsically safe sensor outputs for use in Class I, Div. 1, Groups C and D; Class II, Div. 1, Groups E, F, and G.

#### ATEX

Zone 1, complying with ATEX Directive (94/9/EC) for group II category 2G and marked as EEx de [ib] IIB/IIC T4.

### Performance specifications

See the product data sheet for your sensor.

### Cleaning instructions

To clean the Model 3700 transmitter, use a clean, damp cloth.

**⚠ WARNING**

**Using a dry cloth to clean the display cover of the Model 3350 or 3700 can cause static discharge, which could result in an explosion in an explosive atmosphere.**

To prevent an explosion, use a clean, damp cloth to clean the display cover of the Model 3350 application peripheral or Model 3700 transmitter in an explosive atmosphere.



## Model 3100 accessory

The Model 3100 accessory features relay packs for interfacing with high-energy solenoids, pump starters, or other devices.

### Relay packs

- Three relays
- Solid state, SPST
- Rated at 24 to 250 VAC, 40 mA to 5 A; or 0 to 70 VDC, 5 A
- Energized by discrete outputs

Model 3100 relays are suitable for installation in Zone 2, complying with ATEX Directive (94/9/EC) for Group II, Category 3G, according to CENELEC standard prEN 50021:1998 and marked as:

- EEx n V II T4
- KEMA 97 ATEX 4940 X
- Ambient temperature –20 to 60°C (–4 to 140°F)

Model 3100 relays must be mounted into a suitable and classified enclosure that provides ingress protection of at least IP4X according to EN 60529, taking into account the environmental conditions into which the equipment will be installed and clause 6 of prEN50021:1998.

Cable entries for the enclosure shall comply with clause 7.2.6 of prEN50021:1998.

The external metal parts of the relay (heat sinks) must be connected to the potential equalizing system within the hazardous area.

User-supplied relays to be used for Zone 2 applications must be certified as Category 3 equipment.

For Zone 2 applications in which the Model 3300 application peripheral and Model 3100 or user-supplied relays are to be used as a working combination, both devices must be certified as Category 3 equipment.

Individual relays are not allowed to be replaced; in case of a defective relay, the whole Model 3100 must be replaced to meet the safety requirements.

### Optional NEMA 4X (IP65) housings

NEMA 4X (IP65) housing with cutout

### Battery

This device contains a lithium battery.

#### **WARNING**

**Improper removal of battery can cause an explosion.**

To prevent an explosion during battery removal, phone the Micro Motion Customer Service Department before removing the battery. At the end of its life, the battery must be disposed of as small chemical waste.

## Specifications *continued*

### Hazardous area classifications

#### **ATEX**

Zone 2, complying with ATEX Directive (94/9/EC) for Group II, Category 3G, according to CENELEC standard prEN 50021:1998 and marked as:

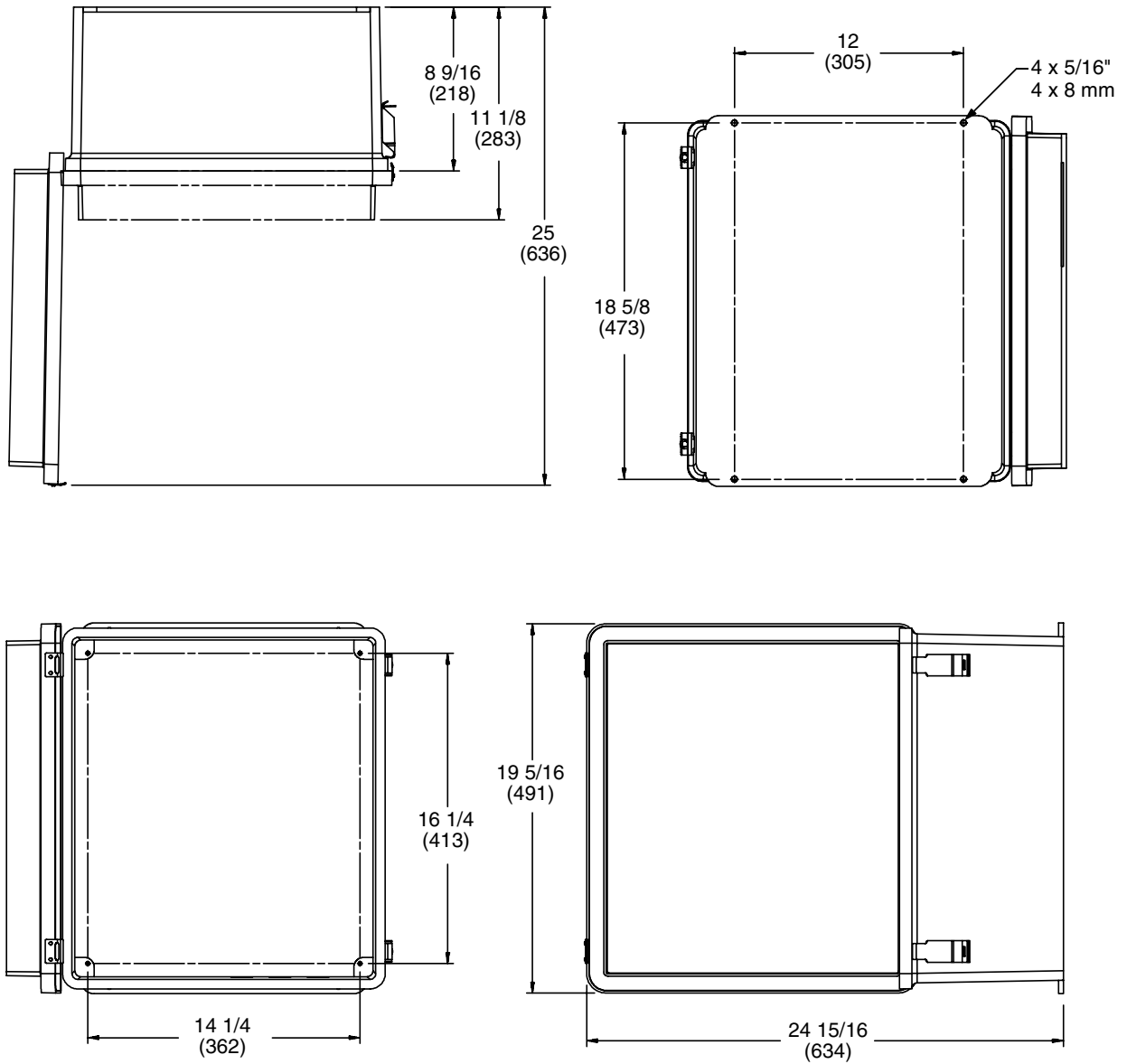
- EEx n V II T4
- KEMA 97 ATEX 4940 X
- Ambient temperature –20 to +60 °C (–4 to +140 °F)

#### **UL and CSA**

Class I, Div. 2, Groups A, B, C, and D

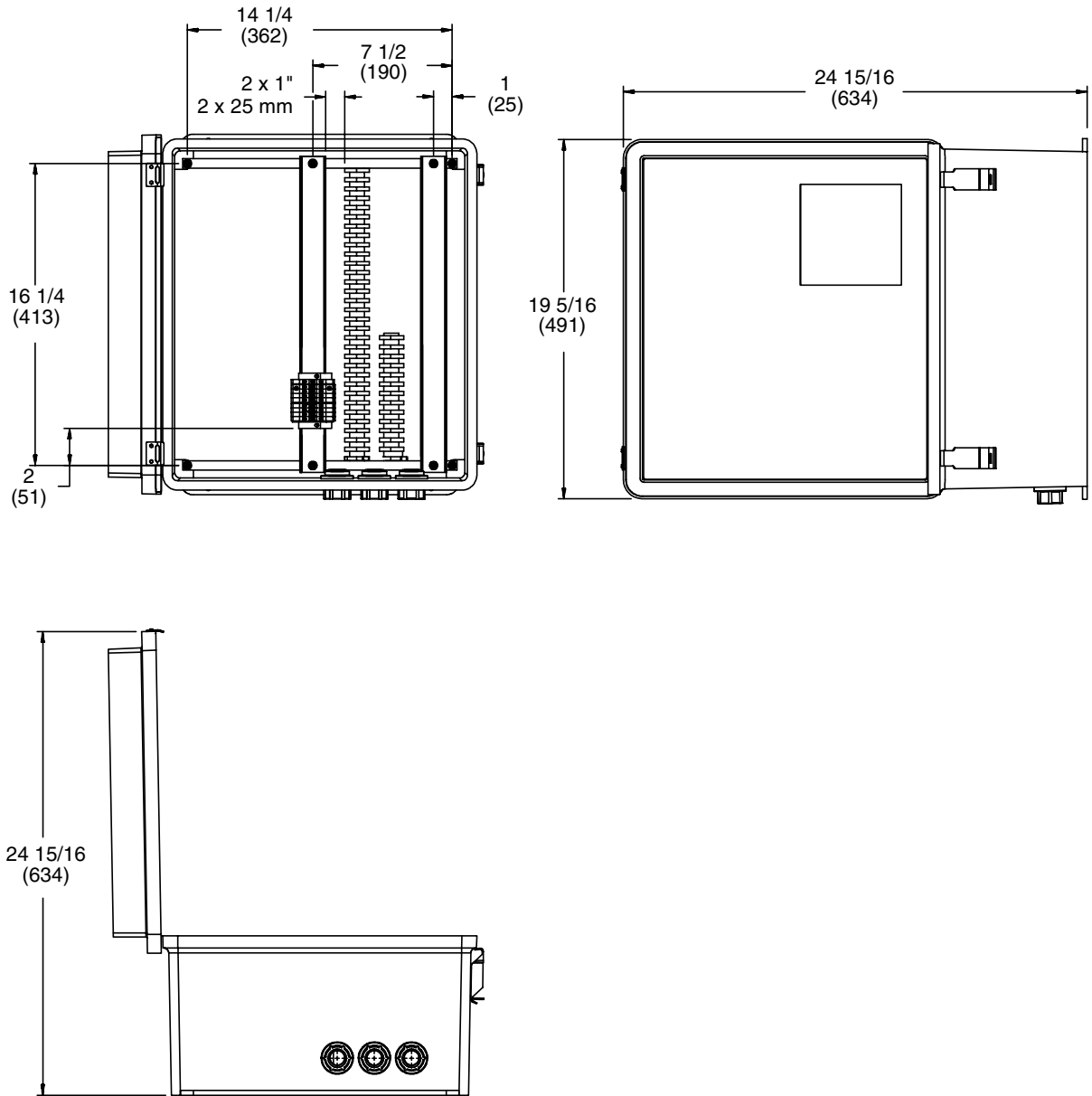
# Appendix B      Optional Housing Dimensions

NEMA 4X (IP65) housing for Model 3300 or 3500



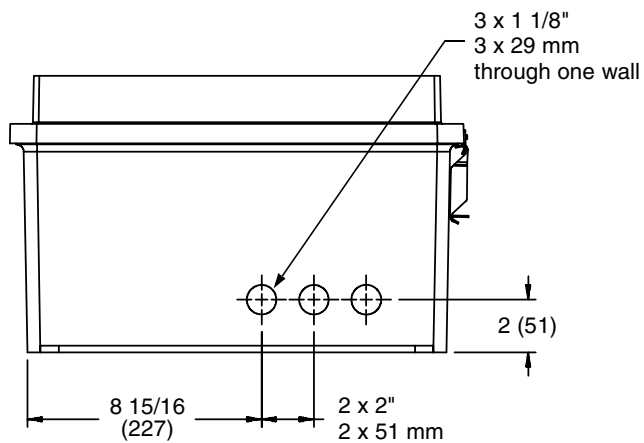
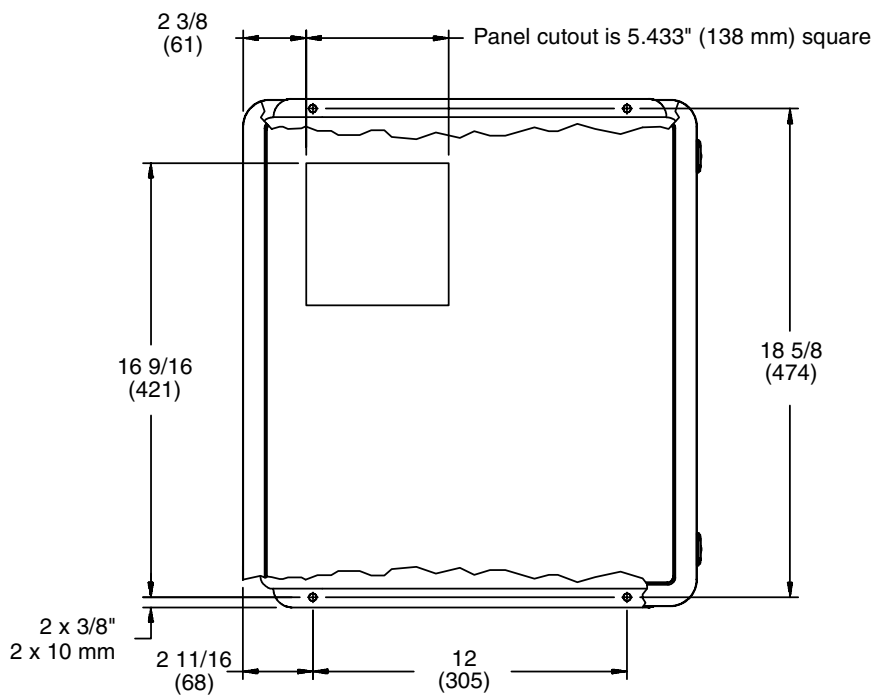
Optional Housing Dimensions *continued*

**NEMA 4X (IP65) housing for Model 3300 or 3500 (continued)**



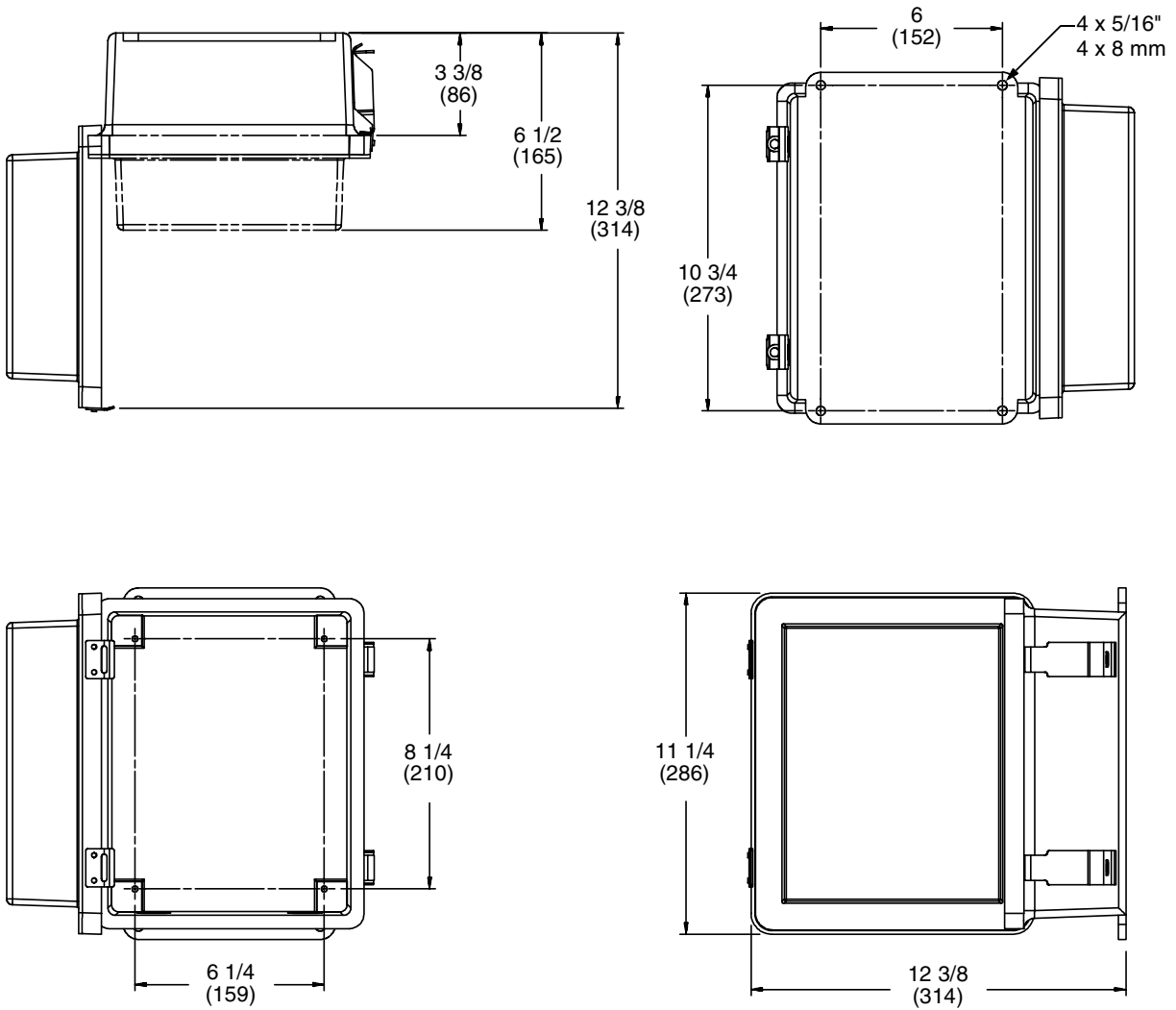
Optional Housing Dimensions *continued*

**NEMA 4X (IP65) housing for Model 3300 or 3500 (continued)**



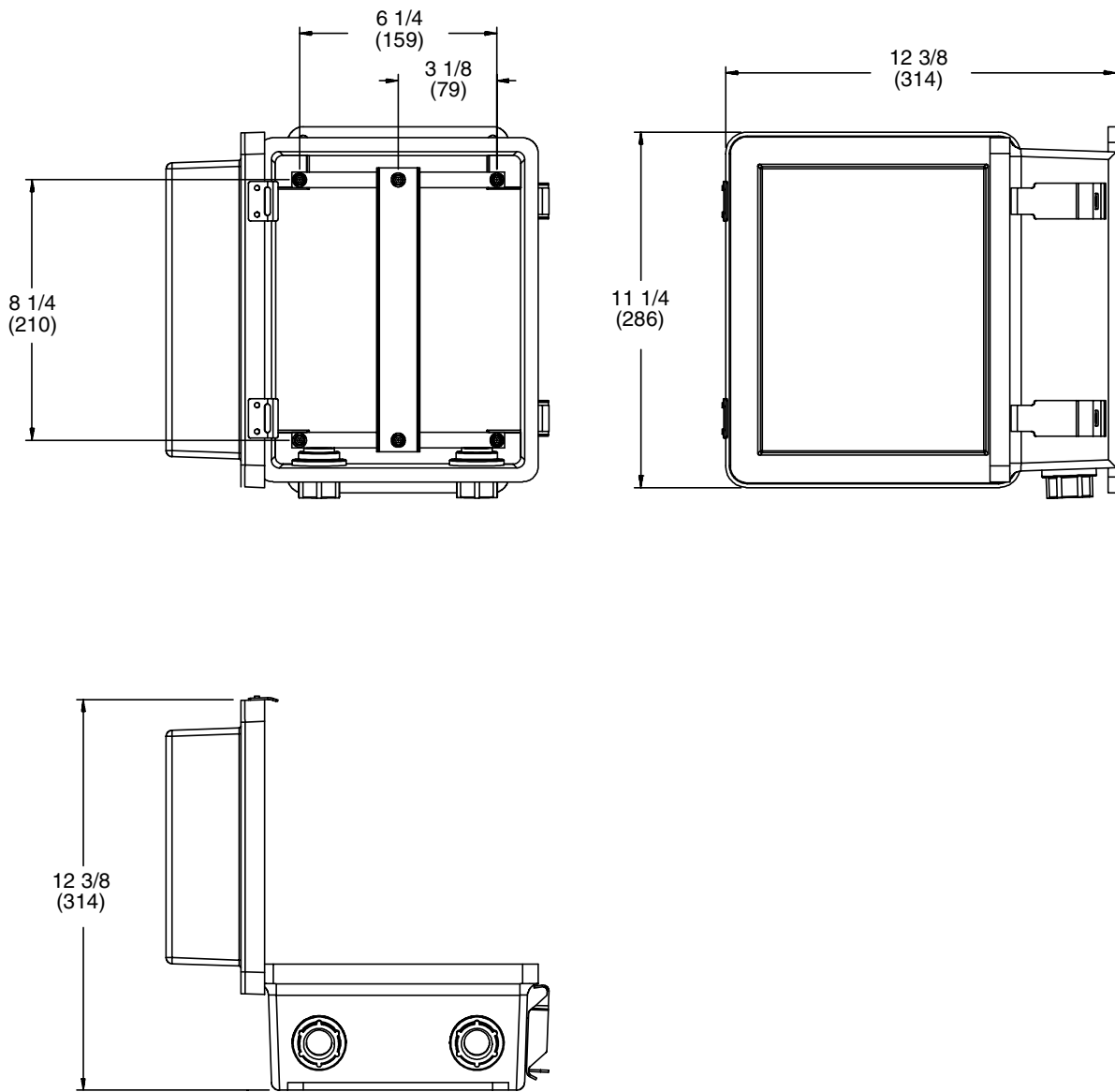
Optional Housing Dimensions *continued*

**NEMA 4X (IP65) housing for Model 3100 relays**



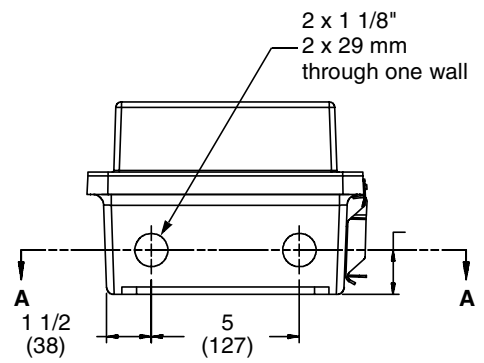
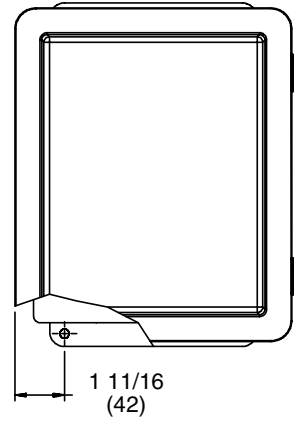
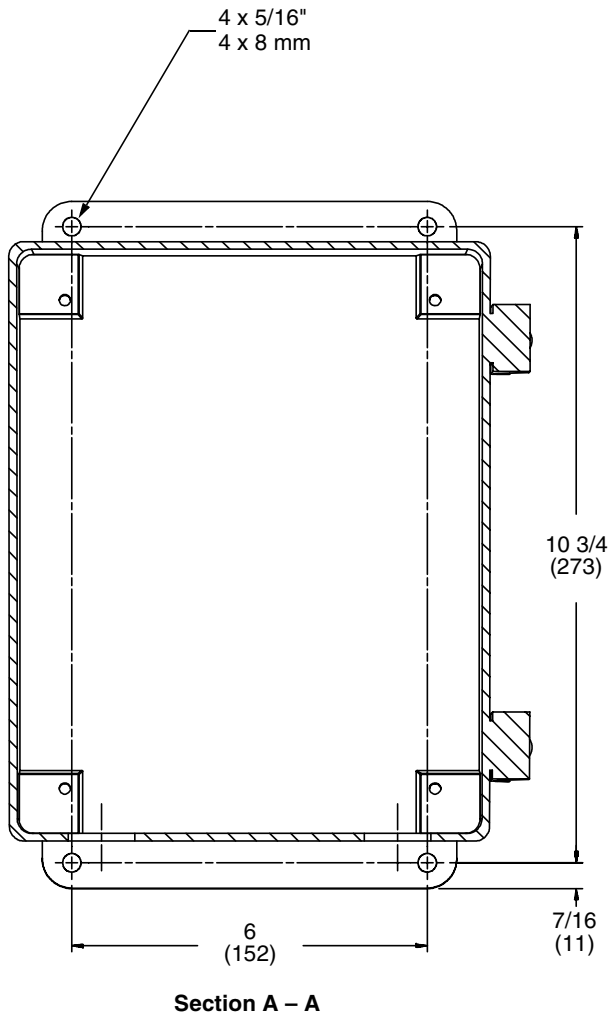
Optional Housing Dimensions *continued*

**NEMA 4X (IP65) housing for Model 3100 relays (continued)**



Optional Housing Dimensions *continued*

NEMA 4X (IP65) housing for Model 3100 relays (continued)





# Appendix C

# Label Maintenance and Replacement

## C.1 Maintaining and replacing labels

Micro Motion product safety labels have been designed in accordance with the voluntary standard, ANSI Z535.4. If the labels illustrated below are illegible, damaged, or missing, promptly have new ones installed.

Contact Micro Motion for replacement labels. Contact information is provided on the title page of this manual.

## C.2 Labels on the device

The Series 3000 applications platform includes the safety labels illustrated below.

Figure C-1 Label number 3300215

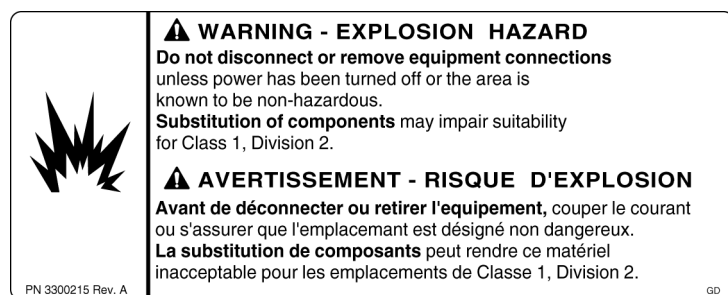
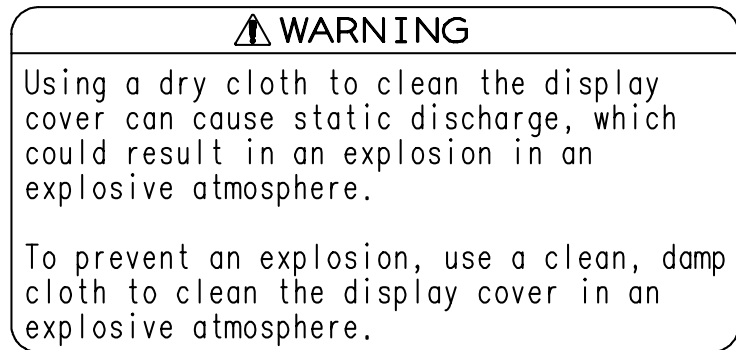


Figure C-2 Label number 3100436



**Figure C-3** Label number 3300709



# Appendix D

# Return Policy

## D.1 General guidelines

Micro Motion procedures must be followed when returning equipment. These procedures ensure legal compliance with government transportation agencies and help provide a safe working environment for Micro Motion employees. Failure to follow Micro Motion procedures will result in your equipment being refused delivery.

Information on return procedures and forms is available on our Web support system at [www.micromotion.com](http://www.micromotion.com), or by phoning the Micro Motion Customer Service Department. Contact information is provided on the title page of this manual.

## D.2 New and unused equipment

Only equipment that has not been removed from the original shipping package will be considered new and unused. New and unused equipment includes sensors, transmitters, or peripheral devices which:

- Were shipped as requested by the customer but are not needed, or
- Were shipped incorrectly by Micro Motion.

New and unused equipment requires a completed Return Materials Authorization form.

## D.3 Used equipment

All equipment that is not classified as new and unused is considered used. This equipment must be completely decontaminated and cleaned before being returned.

Used equipment must be accompanied by a completed Return Materials Authorization form and a Decontamination Statement for all process fluids that have been in contact with the equipment. If a Decontamination Statement cannot be completed (e.g., for food-grade process fluids), you must include a statement certifying decontamination and documenting all foreign substances that have come in contact with the equipment.



# Index

## A

About this manual 1

Approvals

CENELEC

Model 3500 78

UL and CSA

Model 3300 70, 84

Model 3350 73, 82

Model 3500 78

ATEX classification

Model 3100 84

## B

Before You Begin 1

## C

Cable

and conduit preparation 34

gland 34

installation requirements and

recommendations 36

temperature ranges for jacket material 36

types 34

Conduit 34

Configuration

discrete outputs for use with relays 53

mode 62

printer 60

relay power source 44

## H

Hazardous area installations

requiring CENELEC approval

Model 3350 or 3700 24

requiring UL or CSA approval

Model 3350 or 3700 24

Hazardous area requirements

Model 3350/3700 23

relays 43

## I

Installation

in a panel 3

in a subrack 15

Model 3350 or 3700 23

Model 3350/3700

hazardous area requirements 23

relays

factory-supplied 45

user-supplied 50

## L

Location

Model 3350 or 3700 24

panel-mount applications platform 4

rack-mount applications platform 17

## M

Model 3350/3700

hazardous area requirements 23

Mounting

in panel 8

in subrack 20

input/output wiring terminal block 12

Model 3350 or 3700 29

relay terminal block 46

sensor terminal block 38

## N

NEMA 4X (IP65) housing

for Model 3100 relays 88

with cutout 90

with DIN rails 89

for Model 3300 or 3500 85

with cutout 87

with DIN rails 86

## P

Person Process Interface 61

security button 61

security bypass 62

## **Index** *continued*

### Printer setup

- printer test 60
- serial converter
  - ordering or specifying 55
  - wiring connections to 55

## **R**

### Relays

- hazardous area requirements 43
- replacement 44

### Repair and substitution of components 66

### Return goods policy

- international 91–??

### Return policy

- international ??–92

## **S**

### Safety messages 1

### Sensor zero 63

- diagnosing failure of 65
- performing 64
- preparing for 63

### Specifications

- Model 3100 accessory 83
- Model 3300 67
- Model 3350 71
- Model 3500 75
- Model 3700 79
- user-supplied relays 43

### Startup 61

### Symbols 2

## **T**

### Troubleshooting

- alarm messages 66
- diagnosing mechanical zero failure 65
- fault outputs
  - during maintenance 65
  - levels 65
- printer test 60

## **W**

### Wiring

- input/output terminals
  - on Model 3350 or 3700 31
  - on terminal block for panel-mount 13
  - screw-type on rack-mount 22
  - solder tail on rack-mount 22
- power supply
  - Model 3350 or 3700 30
  - panel-mount 9
  - rack-mount 21

### relays

- applications platform to factory-supplied 47
- applications platform to user-supplied 50
- factory-supplied to control devices 48
- user-supplied to control devices 52

### RS-485 terminals 56

### sensor

- connections to transmitter 37
- sensor terminal designations for 37
- transmitter terminal designations for 38

### serial converter

- to Model 3300 or 3500 57
- to Model 3350 or 3700 58

### shields

- Model 3350 or 3700 31
- panel-mount with I/O cable 12
- panel-mount with screw-type terminals 11
- rack-mount 22



©2003, Micro Motion, Inc. All rights reserved. P/N 3300991, Rev. C



For the latest Micro Motion product specifications, view the PRODUCTS section of our Web site at [www.micromotion.com](http://www.micromotion.com)

**Micro Motion Inc. USA**  
Worldwide Headquarters

7070 Winchester Circle  
Boulder, Colorado 80301  
T (303) 530-8400  
(800) 522-6277  
F (303) 530-8459

**Micro Motion Europe**

Emerson Process Management  
Wiltonstraat 30  
3905 KW Veenendaal  
The Netherlands  
T +31 (0) 318 495 670  
F +31 (0) 318 495 689

**Micro Motion Asia**

Emerson Process Management  
1 Pandan Crescent  
Singapore 128461  
Republic of Singapore  
T (65) 6777-8211  
F (65) 6770-8003

**Micro Motion United Kingdom**

Emerson Process Management Limited  
Horsfield Way  
Bredbury Industrial Estate  
Stockport SK6 2SU U.K.  
T 0800 966 180  
F 0800 966 181

**Micro Motion Japan**

Emerson Process Management  
Shinagawa NF Bldg. 5F  
1-2-5, Higashi Shinagawa  
Shinagawa-ku  
Tokyo 140-0002 Japan  
T (81) 3 5769-6803  
F (81) 3 5769-6843

