

# Rosemount™ 935

## Open Path Combustible Gas Detector



## Legal notice

The Rosemount system described in this document is the property of Emerson.

No part of the hardware, software, or documentation may be reproduced, transmitted, transcribed, stored in a retrieval system, or translated into any language or computer language in any form or by any means without prior written permission of Emerson.

While great efforts have been made to ensure the accuracy and clarity of this document, Emerson assumes no responsibility resulting from any omissions in this document or from misuse of the information obtained herein. The information in this document has been carefully checked and is believed to be entirely reliable with all the necessary information included. Emerson does not assume any liability arising out of the application or any use of any product or circuit described herein; neither does it convey license under its patent rights or the rights of others.

### **⚠ WARNING**

All individuals who have or will have responsibility for using, maintaining, or servicing the product must read this manual thoroughly.

### **⚠ WARNING**

#### **Physical access**

Unauthorized personnel may potentially cause significant damage to and/or misconfiguration of end users' equipment. This could be intentional or unintentional and needs to be protected against.

Physical security is an important part of any security program and fundamental to protecting your system. Restrict physical access by unauthorized personnel to protect end users' assets. This is true for all systems used within the facility.

### **⚠ CAUTION**

The source and detector are not field-repairable due to the meticulous alignment and calibration of the sensors and the respective circuits.

Do not attempt to modify or repair the internal circuits or change their settings, as this will impair the system's performance and void the Emerson product warranty.

## Glossary and abbreviations

Abbreviation	Meaning
Analog video	Video values are represented by a scaled signal.
ATEX	Atmosphere explosives
AWG	American wire gauge
BIT	Built-in test
CMOS	Complementary metal oxide semiconductor image sensor
Digital video	Each component is represented by a number representing a discrete quantization.
DSP	Digital signal processing
EMC	Electromagnetic compatibility
EMI	Electromagnetic interference
EOL	End of line
FOV	Field of view
HART®	Highway addressable remote transducer communication protocol
IAD	Immune at any distance
IECEX	International Electrochemical Commission explosion

Abbreviation	Meaning
IP	Internet protocol
IPA	Isopropyl alcohol
IR	Infrared
IR3	Refers to the three infrared sensors
JP5	Jet fuel
Latching	Refers to relays remaining in the On state even after the On condition has been removed.
LED	Light-emitting diode
LEL	Lower explosive limit: The minimum concentration of a substance (gas/vapor) in air mixture that can be ignited. This mixture is different for every gas/vapor, measured in % of LEL.
LEL.m	Integral of concentration in LEL units (1 LEL = 100% LEL) and the operation distance in meters (m).
LNG	Liquified natural gas
LPG	Liquified petroleum gas
mA	MilliAmps (0.001 amps)
Modbus®	Master-slave messaging structure
N.C.	Normally closed
N.O.	Normally open
N/A	Not applicable
NFPA	National Fire Protection Association
NPT	National pipe thread
NTSC	National Television System Committee (a color encoding system)
PAL	Phase alternation by line (a color encoding system)
PN	Part number
RFI	Radio frequency interference
RTSP	Real time streaming protocol
SIL	Safety integrity level
UNC	Unified coarse thread
Vac	Volts alternating current
Vdc	Volts direct current
µm	Micrometer



# Contents

<b>Chapter 1</b>	<b>Product overview.....</b>	<b>7</b>
<b>Chapter 2</b>	<b>Technical description.....</b>	<b>9</b>
	2.1 Features.....	9
	2.2 Applications.....	10
	2.3 Principle of operation.....	10
	2.4 Product certifications.....	12
	2.5 Models and types.....	14
	2.6 Ordering information.....	14
	2.7 Description.....	16
<b>Chapter 3</b>	<b>Operating modes.....</b>	<b>19</b>
	3.1 Operational modes.....	19
	3.2 Visual indicators.....	20
	3.3 Output signals.....	21
	3.4 System setup.....	22
<b>Chapter 4</b>	<b>Specifications.....</b>	<b>25</b>
	4.1 General specifications.....	25
	4.2 Electrical specifications.....	25
	4.3 Mechanical specifications.....	27
	4.4 Environmental specifications.....	28
<b>Chapter 5</b>	<b>Installation.....</b>	<b>31</b>
	5.1 Introduction.....	31
	5.2 General considerations.....	31
	5.3 Preparations for installation.....	33
	5.4 Certification instructions.....	35
	5.5 Special conditions for safe use from ATEX IECEx certificate.....	36
	5.6 Install conduits and cables.....	36
	5.7 Mount detector and source to tilt mount.....	37
	5.8 Wire detector.....	40
	5.9 Wiring to detector terminals.....	41
	5.10 Flash source wiring.....	42
	5.11 Align detector.....	43
<b>Chapter 6</b>	<b>Operation.....</b>	<b>47</b>
	6.1 Open path system operation.....	47
	6.2 Power up.....	47
	6.3 Safety precautions.....	48
	6.4 Verify signal.....	48

	6.5 Zero calibrate.....	50
	6.6 Functional check.....	53
<b>Chapter 7</b>	<b>Maintenance.....</b>	<b>55</b>
	7.1 General maintenance.....	55
	7.2 Periodic maintenance.....	55
<b>Chapter 8</b>	<b>Troubleshooting.....</b>	<b>57</b>
	8.1 Maintenance call.....	57
	8.2 Detector is in constant Obscuration mode.....	57
	8.3 Detector is in constant Saturation mode.....	57
	8.4 Detector is in constant Misalignment mode.....	58
	8.5 Detector at V fault.....	58
	8.6 Internal fault.....	58
	8.7 NQ Ratio below the permitted limit.....	59
	8.8 NQ Ratio above the permitted limit.....	59
	8.9 Ratio out of the limit.....	59
	8.10 Source fault.....	59
<b>Appendix A</b>	<b>Wiring configurations.....</b>	<b>61</b>
	A.1 RS-485 communication network.....	65
<b>Appendix B</b>	<b>SIL-2 features.....</b>	<b>67</b>
	B.1 Safety relevant parameters.....	67
	B.2 General conditions for safe use.....	67
<b>Appendix C</b>	<b>Support.....</b>	<b>69</b>
	C.1 Return of material.....	69
<b>Appendix D</b>	<b>Declaration of Conformity.....</b>	<b>71</b>

# 1 Product overview

The Rosemount 935 Gas Detector employs an advanced xenon flash source and integrated electronics package, both housed in stainless steel housings to provide high quality and performance, fast response, and line of sight gas monitoring. The source/detector is backed by a three year warranty.

The Rosemount 935 detects ambient combustible gases over a path length of up to 660 ft. (200 m) even in harsh environments where dust, fog, rain, snow, or vibration can cause a high reduction of signal. The detector can maintain operation in up to 90 percent signal obscuration and  $\pm 0.5$  degrees of misalignment.

The detector is manufactured with heated optical windows to improve performance in icing, snow, and condensation conditions. The programmable functions are available through a HART® port used with an intrinsically safe (I.S.) handled unit.

The source and detector unit enclosures are ATEX and IECEx approved Exd flameproof with an integral segregated rear and an Exe terminal compartment to prevent exposing the sensors and electronics to the surrounding environment. The detector also has a plug interface for connection to a HART Field Communicator, which is intrinsically safe.

Hence, the combined approval:

Ex II 2(2) G D

Ex db eb ib [ib Gb] IIB+H<sub>2</sub> T4 Gb

Ex tb IIIC T135 °C Db

T<sub>a</sub> = -55 °C to +65 °C





## 2 Technical description

### 2.1 Features

- Long range gas detection from 23 ft. (7 m) up to 660 ft. (200 m)
- Detection of methane, ethylene, or propane gases
- High sensitivity and fast response to hydrocarbon gases
- Heated optics to improve performance in icing, condensation, and snow conditions
- Continuous operation in extreme and harsh environmental conditions
- Solar blind and immune to industrial environments
- Withstands extreme vibration conditions
- Standard 0-20 mA output
- Maintenance call (3 mA)
- HART® protocol: communication protocol
- RS-485 output Modbus®-compatible for personal computer (PC) communication network for a maximum of 247 systems
- Simple one person installation, alignment, and calibration
- ATEX and IECEx per  
Ex II 2(2) G D  
Ex db eb ib [ib Gb] IIB + H<sub>2</sub> T4 Gb  
Ex tb [ib Db] IIIC T135 °C Db  
T<sub>a</sub> = -55 °C to 65 °C
- TUV approved per SIL2 requirements.
- FM / FMC approved per:  
Class I Div. 1 Group B, C, and D  
Class II/III Div. 1 Group E, F, and G
- Functional tested by FM per EN60079-29-4 and approved per FM 6325.
- Programmable configuration via the Field Communicator
- Fast connections to intrinsically safe (I.S.) approved hand-held diagnostic/calibration unit
- Three-year warranty

## 2.2 Applications

The Rosemount 935 system is an optical control fence for combustible gases as defined in the product specification, providing perimeter monitoring and early detection in various applications, such as:

- Petrochemical, pharmaceutical, and other chemicals storage and production areas
- Flammable chemical storage sites and hazardous waste disposal areas
- Refineries, oil platforms, pipelines, refueling stations, and fuel storage facilities
- Hazardous loading docks, transportation depots, and shipping warehouses
- Engine rooms
- Compressor and pumping stations
- Test cells
- Liquefied natural gas (LNG) and liquefied petroleum gas (LPG) systems
- Offshore floating production storage and shipping vessels (FPSO) and fixed oil rigs

## 2.3 Principle of operation

The system detects gases through a dual spectral range monitoring, analyzing the absorption of radiation caused by gases in the atmosphere and comparing it to background atmospheric absorption.

### 2.3.1 Spectral fingerprint

Each hazardous material is detected at a specific wavelength selected according to its specific spectral absorption or **fingerprint**.

The detection process involves two separate sensors, one that absorbs a particular gas and one that is not sensitive to it.

### 2.3.2 Optical path

The presence of hazardous airborne vapors, gases, or aerosols in a monitored area is detected when the defined substance crosses/enters the optical path between the radiation source unit and the detector.

Hazardous gases/vapors present in the atmosphere cause absorption of the radiation pulse in the optical path between the radiation source and the detector unit at specific wavelengths. This causes a change in the signal intensity received by the detector, which is translated into an output related to the detector's measuring scale.

The system analyzes the defined open path at the spectral bands specific to the materials being monitored. The automatic gain control (AGC) unit compensates for environmental disturbances, such as fog, rain, etc., through a constant comparison with its dual spectral beam.

### 2.3.3 Microprocessor based

The built-in microprocessor analyzes the incoming signals.

A sophisticated mathematical algorithm calculates between the various functions of the detected signal thresholds. Statistics, ratio algorithms, data communications, diagnostics, and other functions are performed.

### 2.3.4 Gas sensitivity

The Rosemount 935 model uses wavelengths around 2.3  $\mu\text{m}$  spectral band to measure air flammability potential between the source and the detector.

At this wavelength, many hydrocarbon gases have an absorption peak.

The Rosemount 935 is able to detect other gases, based on cross-sensitivity. Please consult Emerson for information on how to detect other gases.

### 2.3.5 Gas calibration

The detector has three calibrations that can be changed by function setup:

- Gas 1: 100 percent methane
- Gas 2: 100 percent propane
- Gas 3: 100 percent ethylene

The full scale of methane and propane is 5 LEL.m.

The full scale of ethylene is 8 LEL.m.

### 2.3.6 Flash source

The Rosemount 935 transmitter employs the latest generation of Xenon flash bulbs to provide extended installation distance and maximum reliability.

### 2.3.7 Heated optics

The Rosemount 935 includes heated optics for the detector and source.

The heater increases the temperature of the optical surface by 5 to 8 °F (3 to 5 °C) above the ambient temperature to improve performance in icing, condensation, and snow conditions. Emerson has configured the heated optics to automatically operate when the change in temperature requires heating (default).

However, you can also define the heated optics as one of the following modes:

1. Not operated (not an option source unit)
2. On continuously
3. Automatic, per temperature change (default)

See [System setup](#).

When operated in Automatic mode, you can define the start temperature below which the window will be heated (default 41 °F [5 °C]). You can define this temperature between 32 °F (0 °C) and 122 °F (50 °C). The heating stops when the temperature is 27 °F (15 °C) above the start temperature.

## 2.3.8 HART® protocol

The detector uses the HART protocol.

HART communication is a bi-directional, industrial field communications protocol used to communicate between intelligent field instruments and the host system. HART is the global standard for smart instrumentation, and the majority of smart field devices installed in plants worldwide are HART-enabled.

HART technology is easy to use and very reliable.

Through the HART connection, the detector can perform:

- Setup
- Troubleshooting
- Detector health and status

You can connect the HART communication on the 0-20 mA line or through the intrinsically safe (I.S.) connection with a standard Field Communicator loaded with our device driver (DD) software and a special harness.

## 2.3.9 Modbus® RS-485

For more advanced communications, the Rosemount 935 has an RS-485 Modbus-compatible output that provides data communication.

This feature enables simple commissioning, maintenance, and configuration.

## 2.3.10 Tilt mount

The stainless steel tilt mount provides a small installation footprint that can conform to limited space constraints, while the sturdy construction maintains alignment even in constant vibration.

The X and Y axis adjustments provide quick and easy alignment for installation and maintenance.

## 2.4 Product certifications

The open path Rosemount 935 is approved for the following certifications:

- ATEX, IECEx
- FM / FMC
- SIL-2
- Functional test per FM6325 and EN60079-20-4

## 2.4.1 ATEX and IECEx

The Rosemount 935 is approved per:

Ex II 2(2) G D

Ex db eb ib [ib Gb] IIB+H<sub>2</sub> T4 Gb

Ex tb [ib Db] IIIC T135 °C Db

T<sub>a</sub> = -55 °C to +65 °C

## 2.4.2 FM/FMC

The Rosemount 935 is approved to FM/FMC explosion proof per:

- Class I, Div. 1 Group B, C, and D, T<sub>6</sub> -50 °C ≤ T<sub>a</sub> ≤ 65 °C
- Dust ignition proof - Class II/III Div. 1, Group E, F, and G
- Ingress protection - IP66 & IP68, NEMA<sup>®</sup> 250 Type 6P

## 2.4.3 SIL-2

The Rosemount 935 is TUV approved for SIL-2 requirements per IEC61508.

The alert condition according to SIL-2 can be implemented by alert signal via 0-20 mA current loop.

For more details and guidelines on configuring, installing, operating, and servicing, see SIL-2 Features and TUV report number 968/EZ619.00/13.

## 2.4.4 Functional approval

The Rosemount 935 was functionally approved per FM6325.

The Rosemount 935 was functionally tested by FM per EN60079-29-4.

## 2.5 Models and types

The Rosemount 935 includes four models with the same detector and different sources. That gives the detector the ability to get detection at distances of 23 to 660 ft. (7 to 200 m).

**Table 2-1: Model numbers and installation distances**

Model number	Source	Minimum installation distance	Maximum installation distance
935	T1	23 ft. (7 m)	66 ft. (20 m)
935	T2	50 ft. (15 m)	132 ft. (40 m)
935	T3	115 ft. (35 m)	330 ft. (100 m)
935	T4	265 ft. (80 m)	660 ft. (200 m)

## 2.6 Ordering information

You can order the Rosemount 935 as separate parts: source (PN TXFXXXXX), detector (PN R1F00XXXX), and commissioning kit (PN 88247-X).

### 2.6.1 Online product configurator

Many products are configurable online using our product configurator.

Visit our [website](#) to start. With this tool's built-in logic and continuous validation, you can configure your products more quickly and accurately.

### 2.6.2 Model codes

Model codes contain the details related to each product.

Exact model codes will vary; examples of typical model codes are shown in [Source \(Transmitter\)](#) and [Detector \(Receiver\)](#).

#### **Source (Transmitter)**

935T1F002SA1

#### **Detector (Receiver)**

935R1F012SA1

### 2.6.3 Specifications and options

See [Specifications](#) for more details on each configuration.

Specification and selection of product materials, options, or components must be made by the purchaser of the equipment.

## 2.6.4 Source (Transmitter)

### Required model components

#### Model

Code	Description
935	Rosemount 935 Combustible Open Path Gas Detector Source (Transmitter)

#### Transmitter range

Code	Description
T1	Transmitter - Range of 23 to 66 ft (7 to 20 m)
T2	Transmitter - Range of 50 to 132 ft (15 to 40 m)
T3	Transmitter - Range of 115 to 330 ft (35 to 100 m)
T4	Transmitter - Range of 265 to 660 ft (80 to 200 m)

#### Gas calibration

Code	Description
F00	Transmitter

#### Housing style / conduit

Code	Material	Measurement
2S	Stainless steel	¾-in NPT
4S	Stainless steel	M25

#### Product certifications

Code	Description
A1	ATEX and IECEx
A2	FM
E2	INMETRO
EM	CU TR (EAC)

## 2.6.5 Detector (Receiver)

### Required model components

## Model

Code	Description
935	Combustible Open Path Gas Detector (Receiver)

## Receiver selection

Code	Description
R1	Receiver

## Gas calibration

Code	Description
F01	Receiver for combustible gases Methane full scale 5 LEL.m (default)

## Housing style / conduit

Code	Material	Measurement
2S	Stainless steel	¾-in NPT
4S	Stainless steel	M25

## Product certifications

Code	Description
A1	ATEX and IECEx
A2	FM
E2	INMETRO
EM	CU TR (EAC)

## 2.7 Description

The Rosemount 935 comprises two main units:

- Flash infrared source
- Detector

The Rosemount 935 detects gases over an open path transmitted from the source to the detector.

### 2.7.1 Flash source unit

The flash source unit emits infrared (IR) radiation pulses at the rate of two pulses per second. The pulse width (5-10 µsec) is very powerful. The front of the source has a lens that collimates the IR beam for maximum intensity. The front window is heated to improve performance in icing, condensation, and snow conditions.



Figure 2-1: Flash source

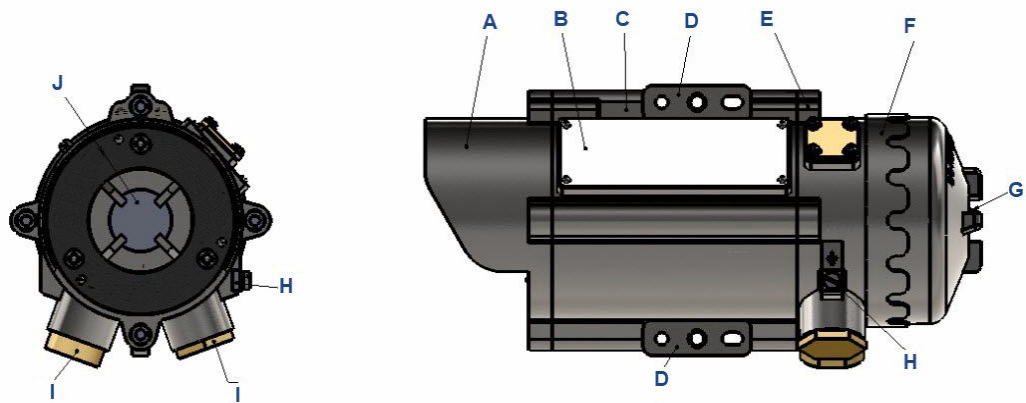

- A. Front window section
- B. Label
- C. Main housing
- D. Mounting plate
- E. Junction box
- F. Back cover
- G. Indication light-emitting diode (LED)
- H. Earth terminal
- I. Cable inlets
- J. Front window

## 2.7.2 Detector unit

The detector receives the transmitted pulsed radiation signals from the source. The signals are then amplified and fed into an analog to digital signal converter to be processed by the internal microprocessor.

When the signals drop below a prescribed level, the internal microprocessor compensates for them. This allows the signals to be maintained even in severe weather conditions. The data is sent to the output interface section.

The front window of the detector is heated to improve performance in icing, condensation, and snow conditions.

There is one detector type that is suitable for all models

**Figure 2-2: Detector**

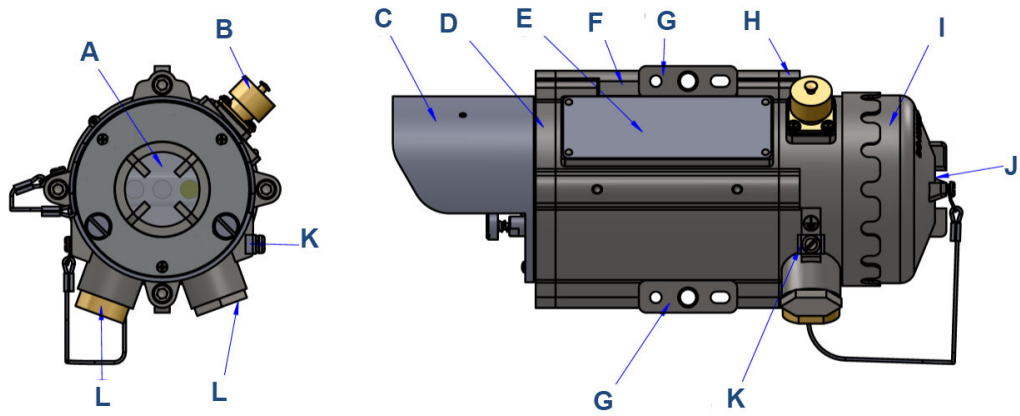

- A. Front window
- B. Handheld fast connection
- C. Weather shield
- D. Front window section
- E. Label
- F. Main housing
- G. Mounting plate
- H. Junction box
- I. Back cover
- J. Indicator light-emitting diode (LED)
- K. Earth terminal
- L. Cable inlet

## 3 Operating modes

### 3.1 Operational modes

The Rosemount 935 has four operational modes:

- Normal mode
- Maintenance call mode (3 mA output)
- Fault mode
- Zero calibration mode (1 mA output)

#### 3.1.1 Normal mode

This mode is used for gas detection. In Normal mode, the following statuses are possible:

- Normal (N): Signal received from gas detection is at safe levels.
- Warning (W): Gases have been detected at warning levels.
- Alarm (A): Gases have been detected at alarm levels.

#### NOTICE

For the standard 0-20 mA output, the warning and alarm levels are not relevant. Choose these alarm levels at the controller. The output detector is at 4 mA at zero reading and 20 mA for full-scale reading.

View warning and alarm states through the light-emitting diode (LED), RS-485, and HART®.

If using the RS-485 output, the detector changes its status from **N** to **W** at Warning level and to **A** at Alarm level.

#### 3.1.2 Maintenance call mode (3 mA output)

This mode indicates low signal that may be caused by a dirty window, misalignment, or poor source or if one of the detector's parameters is at the **limit** value.

The detector continues to function, but provides a (3 mA) pre-warning signal (via HART® and Modbus®) that a maintenance procedure is required.

#### 3.1.3 Fault mode

In the fault status, there are three fault types.

In all fault types, the light-emitting diode (LED) flashes yellow at 4 Hz.

- Misalignment (2.5 mA) - non-critical  
This occurs due to poor alignment. Detection is no longer possible.

- **Fault 1 (2 mA output) - non-critical**  
If this occurs, it is due to blockage, very low signal, partial obscuration, or full beam block. In this situation, detection is no longer possible. The detector's proper operation can be restored (auto reset) during operation if the condition causing the problem is removed or resolved. This mode occurs after a delay of 60 seconds from the moment of the fault. This delay is important to eliminate momentary obscuration due to passing through the beam.
- **Fault 2 (1 mA output) - critical**  
In this case, the detector is disabled due to electrical/software operational failure, central device (memory or processor) fault, or low voltage. This fault causes the detector to cease operation.  
If there is a fault in the 0-20 mA loop, the output is 0 mA.

### 3.1.4 Zero calibration mode (1 mA output)

This mode zeroes the base level from which the detector reads gas.

Only do this when:

- No gases are present.
- There is a clear path between the source and the detector.
- Weather conditions are clear.

Use the Field Communicator or host software on your personal computer (PC) to zero calibrate after installation, re-alignment, and window cleaning. In parallel, while the detector is connected to the Field Communicator, the magnetic mode selector can be used for zero calibration.

#### Related information

[Zero calibrate](#)

## 3.2 Visual indicators

One three color light-emitting diode (LED) indicator is located in the back side of the detector/source and can be seen through the back cover window.

See [Figure 2-2](#)

The detector statuses are listed in [Table 3-1](#).

**Table 3-1: Detector LED indications**

Detector status	LED color	LED mode
Fault	Yellow	4 Hz - flashing
Alignment / Standby	Yellow	1 Hz - flashing
Zero calibration	Yellow	Constant
Normal	Green	1 Hz - flashing
Warning	Red	2 Hz - flashing
Alarm	Red	Constant

The source statuses are listed in [Table 3-2](#).

**Table 3-2: Source LED indications**

Source status	LED color	LED mode
Fault	Yellow	4 Hz - flashing
Normal	Green	1 Hz - flashing

## 3.3 Output signals

The Rosemount system provides the following outputs:

- 0 - 20 mA current output
- RS-485 interface

### 3.3.1 0-20 mA current output

The 0-20 mA output provides the detector status measurements showing a continuous reading of exact gas concentration.

The 0-20 mA functions as current sink, but it can be reconfigured as source (see [Wiring configurations](#)).

The maximum permitted load resistance for the 0-20 mA output is 500 Ω.

**Table 3-3: Standard 0-20 mA Current for the Gas Channel**

Current reading	Status and description
0 mA + 0.2 mA	Fault in 0-20 mA loop
1 mA ± 0.2 mA	Zero calibration (in progress), fault 2
2 mA ± 0.2 mA	Fault 1 (non-critical)
2.5 mA ± 0.2 mA	Misalignment fault
3 mA ± 0.2 mA	Maintenance call
4 mA ± 0.2 mA	No gas present
4 mA - 20 mA	Continuous measuring of gas concentrations at a range between 0 and full scale. For methane and propane, this translates to 3.2 mA per LEL.m and for ethylene to 2 mA per LEL.m.
21 mA	Concentration is over the range limit (more than full-scale concentration).

### 3.3.2 RS-485 interface

The RS-485 input/output sends complete data information to a PC and receives data or control commands from the PC.

The protocol is Modbus<sup>®</sup>-compatible. Winhost software is available for download from the product web page. Please contact Emerson for more information.

## 3.4 System setup

This section includes the following topics:

- Detection function programming
- Detection setup function
- Detector default setup

### 3.4.1 Program detection functions

The Rosemount 935 incorporates several functions that can be set by the customer using:

- WinHost software
- HART® Field Communicator: The detector is equipped with an intrinsically safe connector to enable HART communication.

### 3.4.2 Set up detection function

See [Setting up detector defaults](#) for default settings.

#### Gas calibration

You can select three gas types for maximum compatibility to the required gas(es).

Gas types:

- Methane: full scale 5 LEL.m
- Propane: full scale 5 LEL.m
- Ethylene: full scale 8 LEL.m

These three calibrations are standard calibrations.

The Rosemount 935 is able to detect other gases, based on cross-sensitivity. Please consult Emerson for information on how to detect other gases.

#### Setting up addresses

The detector provides up to 247 address that can be used in the RS-485 communication link and up to 64 addresses that can be used in the HART® Field Communication link.

#### Heated optic operation

The heated optics for the detector unit can be defined as one of the following modes:

- |             |                                     |
|-------------|-------------------------------------|
| <b>Off</b>  | Not operated                        |
| <b>On</b>   | Operated continuously               |
| <b>Auto</b> | On per temperature change (default) |

When operated in Automatic mode, you can define the start temperature below which the window will be heated between 32 and 122 °F (0 and 50 °C). The detector stops heating the window when the temperature is 27 °F (15 °C) above the defined temperature.

This feature relates to the detector **only**.

The source heated optic must be defined within the model structure in two options:

- Heated continuously
- Start heating below 41 °F (5 °C)

### 3.4.3 Setting up detector defaults

The detector has three functions which can be programmed according to the customer requirements at the factory or at the customer facility using a software host or a Field Communicator, available for download from the product web page.

Please contact Emerson for more information.

The standard setup is as follows:

**Table 3-4: Detector Default Setup**

Function	Setup
Gas type	Methane
Heat mode	Auto
Heat on	41 °F (5 °C)

You can change the source defaults the same way.

**Table 3-5: Source Default Setup**

Function	Setup
Heat mode	Auto
Heat on	41 °F (5 °C)





# 4 Specifications

## 4.1 General specifications

Detected gases: C1 - C8 selective gases

Detection distance range: [Table 4-1](#)

**Table 4-1: Model Numbers and Installation Distances**

Model number	Detector	Source	Minimum installation distance	Maximum installation distance
935	R1F00XXXX	T1FXXXXXX	23 ft. (7 m)	66 ft. (20 m)
935	R1F00XXXX	T2FXXXXXX	50 ft. (15 m)	132 ft. (40 m)
935	R1F00XXXX	T3FXXXXXX	115 ft. (35 m)	330 ft. (100 m)
935	R1F00XXXX	T4FXXXXXX	265 ft. (80 m)	660 ft. (200 m)

**Response time:** 3 sec to T90

**Spectral response:** 2.0 - 3.0 micron

**Sensitivity range:**

		Full scale LEL.m	Warning LEL.m	Alarm LEL.m
Gas 1	Methane	5	1	3
Gas 2	Propane	5	1	3
Gas 3	Ethylene	8	1.6	4.8

**Field of view:** Line of sight

**Alignment tolerance:**  $\pm 0.5^\circ$

**Drift:**  $\pm 7.5\%$  of the reading or  $\pm 4\%$  of the full scale (whichever is greater)

**Minimum detectable gas volume:** 0.15 LEL.m

**Temperature range:**  $-67^\circ\text{F} (-55^\circ\text{C})$  to  $149^\circ\text{F} (65^\circ\text{C})$

**Immunity to false alarm:** Does not produce false alarm and is not influenced by solar radiation, hydrocarbon flames, and other external infrared (IR) radiation sources.

## 4.2 Electrical specifications

**Operating voltage**

18-32 Vdc

## Power consumption

**Table 4-2: Detector and Source Maximum Power Consumption**

	Without heated optic (max.)	With heated optic (max.)
Detector	150 mA	300 mA
Source	200 mA	300 mA

## Electrical input protection

The input circuit is protected against voltage-reversed polarity, voltage transients, surges, and spikes, according to EN50270.

## Electrical outputs

- 0-20 mA current output: The 0-20 mA is an isolated sink option. You can also configure this output as source (see [Wiring configurations](#)).  
The maximum permitted load resistance is 500 Ω.
- Communication network: The detector is equipped with an RS-485 communication link that can be used in installations with computerized controllers. Communication is compatible with the Modbus® protocol.
  - This protocol is standard and widely used.
  - It enables continuous communication between a single standard Modbus controller (master device) and a serial network of up to 247 detectors.
  - It enables connection between different types of Rosemount detectors or other Modbus devices to the same network.
- HART® protocol: A digital communication protocol used to communicate between intelligent field instruments and the host system. Through the HART protocol, the detector can:
  - Display setup.
  - Reconfigure setup.
  - Display and determine the detector status.
  - Perform detector diagnostics.
  - Troubleshoot.

## 4.2.1 Power consumption

**Table 4-3: Detector and Source Maximum Power Consumption**

	Without heated optic (max.)	With heated optic (max.)
Detector	200 mA	250 mA
Source	200 mA	250 mA

## 4.2.2 Electrical input protection

The input circuit is protected against voltage-reversed polarity, voltage transients, surges, and spikes according to EN50270.

## 4.3 Mechanical specifications

### Enclosure

The detector, source, and tilt mount are stainless steel, 316 electro chemical, and passivized coating.

### Explosion proof

ATEX and IECEx

Ex II 2(2) G D

Ex db eb ib [ib Gb] IIB+H2 T4 Gb

Ex tb [ib Db] IIIC T135 °C Db

### Water and dust tight

IP66 and IP68

NEMA® 250 Type 6p

### Electrical modules

Conformal coated

### Electrical connection

Two options, specified at time of order:

- 2 x M25 (ISO)
- 2 x ¼-in.-14 national pipe thread (NPT) conduits

### Dimensions

- Detector: 10.5 x 5.1 x 5.1 in. (267 x 130 x 130 mm)
- Source: 10.5 x 5.1 x 5.1 in. (267 x 130 x 130 mm)
- Tilt mount: 4.7 x 4.7 x 5.5 in. (120 x 120 x 140 mm)

### Weight

Detector: 11 lb. (5 kg)

Source: 11 lb. (5 kg)

Tilt mount: 4.2 lb. (1.9 kg)

## 4.4 Environmental specifications

The Rosemount 935 system is designed to withstand harsh environmental conditions.

The source and detector units compensate for adverse conditions while maintaining accuracy.

### High temperature

The Rosemount 935 conforms to DNVGL-CG-0339, class D.

**Operating temperature** 149 °F (65 °C)

**Storage temperature** 149 °F (65 °C)

### Low temperature

The Rosemount 935 system conforms to DNVGL-CG-0339, class D.

**Operating temperature** -67 °F (-55 °C)

**Storage temperature** -67 °F (-55 °C)

### Humidity

The Rosemount 935 confirms to DNVGL-CG-0339, class B.

### Enclosure

The Rosemount 935 system conforms to DNVGL-CG-0339, class C.

### Water and dust

- IP68 per EN60529
- IP66 per EN60529

**Dust** Completely protected against dust.

**Liquids** Protected against immersion between 5.9 in. (15 cm) and 3.3 ft. (1 m) in depth.  
Protected against water jets from all directions.

### Vibration

The Rosemount 935 system conforms to DNVGL-CG-0339, class B.

### Electromagnetic compatibility (EMC)

This product is in conformance with EMC per EN50270.

**Radiated emission** EN55022

**Conducted emission** EN55022

**Radiated immunity** EN61000-4-3

**Conducted immunity** EN61000-4-6

**Electrostatic discharge (ESD)** EN61000-4-2

**Burst** EN61000-4-4

**Surge** EN61000-4-5

**Magnetic field** EN61000-4-8

To fully comply with EMC directive 2014/30/EU and protect against interference caused by radio frequency interference (RFI) and electromagnetic interference (EMI), the cable to the detector must be shielded, and the detector must be grounded. Ground the shield at the detector end.



# 5 Installation

## 5.1 Introduction

Use general purpose common tools and equipment to install and maintain the detector and source units.

Ensure that suitably qualified personnel install the equipment.

This section does not attempt to cover all of the standard practices and codes of installation. Rather, it emphasizes specific points of consideration and provides some general rules for suitably qualified personnel. It also stresses special safety precautions whenever applicable.

## 5.2 General considerations

### 5.2.1 Personnel

Only employ suitably qualified personnel who are familiar with the local codes and practices and trained for gas detection maintenance.

Ensure that wiring is only performed and supervised by someone with knowledge of electronics and, in particular, wiring installation.

### 5.2.2 Required tools

You can install the detector using general purpose common tools and equipment.

**Table 5-1: Tools**

Tool	Function
Alignment kit	Provides tools to install fine alignment tool.
Hex key 8 mm	Mounts the detector on the tilt mount.
Hex key 3/16 in.	Aligns the detector.
Hex key 5/16 in.	Screws 3/4 stop plug.
Flat screwdriver 4 mm	Connects ground terminal.
Flat screwdriver 2.5 mm	Connects wires to the terminal block.

### 5.2.3 Site requirements

When installing the Rosemount 935, take into account the weight of the monitored gas compared to that of the surrounding air and the individual site requirements.

Ensure that the site selected gives the detector a direct view to the source. The mounting point for each item should be secure and stable with minimal vibrations. Mount the

equipment in a position where it cannot be knocked out of alignment and is guarded from physical impact.

## 5.2.4 Source and detector

Select the appropriate detector for the length of open path to be monitored.

To allow for aging of the source and a reduction of the infrared signal due to adverse weather, Emerson recommends using a detector that is not at the limit of its operating range.

The general recommendation is to install the detector at a distance from the source of not more than 75 percent of the specified operating distance. In severe weather conditions, such as offshore oil production and exploration, reduce this distance to 50 percent.

Keep the open path between the source and detector clear of any obstacles that might hinder the free movement of air in the protected area or block the infrared beam.

## 5.2.5 Tips for gas detector locations

To provide the best detection coverage, install the detector:

- Below potential leak source for gases heavier than air.
- Above potential leak sources for gases lighter than air.
- Near to leak sources along the expected leak trajectory, taking into account prevailing wind directions.

### **⚠ CAUTION**

For optimal performance, avoid placing the detector in locations frequently covered by steam.

## 5.2.6 Separation distances

To avoid cross talk between adjacent Open Path Gas Detector (OPGD) systems where transmitters are installed on the same side, keep the relevant separation distance between the neighboring OPGD systems according to the installation lengths as listed in [Table 5-2](#).

**Table 5-2: Minimum Separation Distances**

Installation line of sight distance, ft. (m)	Minimum separation, ft. (m)
33 (10)	3.3 (1)
66 (20)	5 (1.5)
98 (30)	6.5 (2.5)
131 (40)	11.5 (3.5)
164 (50)	15 (4.5)
197 (60)	16.5 (5)
230 (70)	20 (6)



**Table 5-2: Minimum Separation Distances (continued)**

Installation line of sight distance, ft. (m)	Minimum separation, ft. (m)
262 (80)	23 (7)
295 (90)	26 (8)
328 (100)	28 (8.5)
361 (110)	29.5 (9)
394 (120)	33 (10)
427 (130)	34.5 (10.5)
459 (140)	38 (11.5)
492 (150)	42.5 (13)
525 (160)	47.5 (14.5)
558 (170)	49 (15)
591 (180)	51 (15.5)
623 (190)	52.5 (16)
656 (200)	54 (16.5)

## 5.2.7 Wiring

For wiring, use color-coded conductors or suitable wire markings or labels.

- The wire cross-section must be between 28 to 14 AWG (0.5 mm<sup>2</sup> to 2.5 mm<sup>2</sup>).
- The selected wire gauge should be based on the number of detectors used on the same loop and the distance from the control unit. The maximum number of wire connections in one terminal is two wire cross-sections, each 1 mm<sup>2</sup>.
- To fully comply with electromagnetic compatibility (EMC) directive and protect against interference caused by radio frequency interference (RFI) and electromagnetic interference (EMI), the cable to the detector must be shielded, and the detector must be grounded. Ground the shield at the detector end.

## 5.3 Preparations for installation

Ensure that installation complies with local, national, and international regulations and norms as applicable to gas detectors and approved electrical devices installed in hazardous areas.

### 5.3.1 Equipment

The system should include the following (in addition to the Quick Start Guide):

**Figure 5-1: Box Contents**



Commissioning kit (not pictured)

- A. Source or detector (per box)
- B. Tilt mounts

- Detector unit: 935-R1F00XXXX (see [Table 2-1](#))
- Source unit: 935-TXFXXXXXX (see [Table 2-1](#)).
- Two tilt mount bases (one for the source and one for the detector).<sup>(1)</sup>
- Commissioning kit, three options when ordered:
  - For methane calibration
  - For propane calibration
  - For ethylene calibration

The commissioning kit includes:

- Alignment tool kit
- Function check filters
- HART® hand-held harness kit

Other accessories are available (per customer request):

- 5-in. pole mount kit
- 2 to 3-in. pole mount
- Wall mount
- Protective cover

---

**Note**

See the *Rosemount 935 Product Data Sheet* for accessory part numbers.

---

<sup>(1)</sup> If you order a source or detector separately, you will receive one tilt mount.

## 5.3.2 Unpacking

Upon receipt of your detector, check and record the following:

- Verify the appropriate purchase order. Record the part number and the serial number of the detectors and source units and the installation date in the appropriate log book.
- Open the container package immediately prior to detector installation and visually inspect the detectors, sources, and accessories.
- Verify that all components required for detector installation are readily available before commencing the installation. In the event that the installation is not completed in a single session, secure and seal detectors and conduits.

## 5.4 Certification instructions

### **⚠ WARNING**

#### **EXPLOSION**

Do not open the detector, even when isolated, in a flammable atmosphere.

- The cable entry point may exceed 182 °F (83 °C). Take suitable precautions when selecting the cable.
- The equipment may be used with flammable gases and vapors with apparatus groups IIA and IIB+H2 T4 in the ambient temperature range: -67 to +149 °F (-55 to +65 °C).
- Only suitably trained personnel shall install the detector in accordance with the applicable code of practice, e.g., EN 60079-14: 1997.
- Only suitably trained personnel shall inspect and maintain this equipment in accordance with the applicable code of practice, e.g., EN 60079-19.
- Only suitably trained personnel shall repair this equipment in accordance with the applicable code of practice, e.g., EN 60079-19.
- The certification of this equipment relies upon the following materials used in its construction:
  - Enclosure: Stainless steel 316
  - Windows: sapphire glass
  - Seals: EPDM
- If the equipment is likely to come into contact with aggressive substances, then it is your responsibility to take suitable precautions that prevent it from being adversely affected, thus ensuring that the type of protection provided by the equipment is not compromised.
  - Aggressive substances: For example, acidic liquids or gases that may attack metal or solvents that may affect polymeric materials.
  - Suitable precautions: For example, regular checks as part of routine inspections or establishing from the material's safety data sheets that it is resistant to specific chemicals.

## 5.5 Special conditions for safe use from ATEX IECEx certificate

The dimensions of the flameproof joints differ from the relevant minimum or maximum values required by Table 2 of IEC/EN 60079-1: 2007 for IIB + H<sub>2</sub>, as detailed in [Table 5-3](#).

**Table 5-3: Flamepaths**

Flamepath description	Type of joint	Minimum width "L" in inches (millimeters)	Maximum gap "i <sub>c</sub> " in inches (millimeters)
Cylindrical section of spigot (both ends of Ex d compartment)	Cylindrical	0.59 (15)	0.003 (0.08)
1.2-in. (30 mm) diameter window fitted against enclosure	Flanged	0.42 (10.7)	0.001 (0.02)
1.6-in. (39.5 mm) diameter window fitted against enclosure	Flanged	0.39 (10)	0.001 (0.02)

- Gaps, "i<sub>c</sub>", should not be modified to be any larger, and widths, "L", should not be modified to be any shorter than the values in [Table 5-3](#).
- Connections to the intrinsically safe (I.S.) port on the side of the detector enclosure should be made using equipment that maintains the intrinsically safe levels of protection.
- The Um should be installed in accordance with one of the following:
  - The Um is 18 to 32 Vdc in a SELV/PELV system.
  - Via a safety isolating transformer, complying with the requirements of IEC 61588-2-6 or technically equivalent standard.
  - Directly connected to apparatus, complying with IEC 60950, IEC 61010-1, or technically equivalent standard.
  - Fed directly from cells or batteries.
- If the product is to be used as a safety related device, an appropriate independent certification, would be required meeting all the requirements.

## 5.6 Install conduits and cables

The conduit and cable installation must comply with the following guidelines:

- To avoid water condensation in the detector, install it with the conduits/cable entries facing downwards.
- Use flexible conduits/cables for the last portion connecting to the detector.
- When pulling the cables through the conduits, ensure that they are not tangled or stressed. Extend the cables about 12-in. (30 cm) beyond the detector location to accommodate wiring after installation.

- After pulling the conductor cables through the conduits, perform a continuity test.

## 5.7 Mount detector and source to tilt mount

You can install the detector and source in two ways with the same tilt mount by using the upper or lower mounting access.

**Figure 5-2: Mounting the Tilt Mount and Detector Using the Lower Mounting Access**

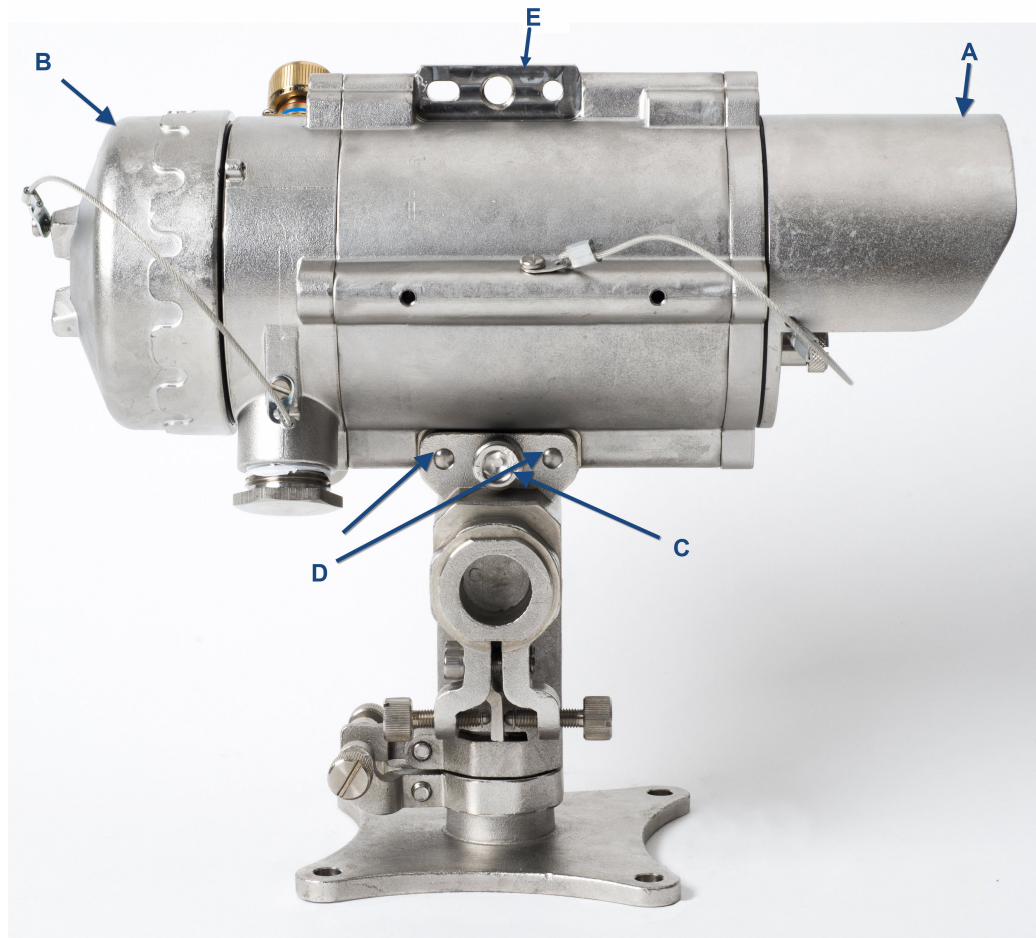

- A. Front shield
- B. Back cover
- C. Security screw
- D. Locating pins
- E. Alternate mounting location

**Figure 5-3: Tilt Mount**

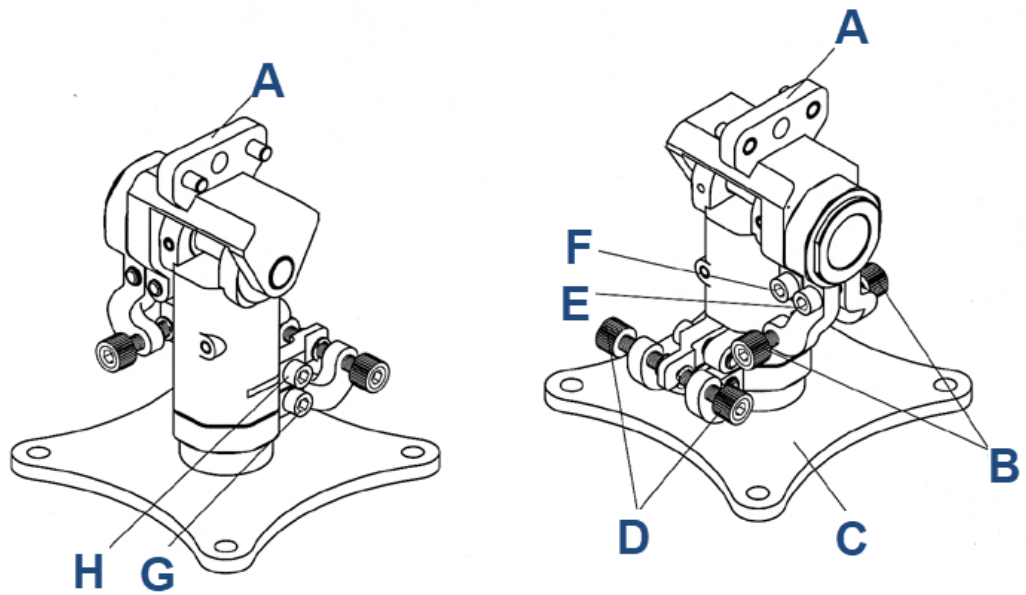

- A. Detector/source holding plate
- B. Vertical fine alignment screw
- C. Tilt mount holding plate
- D. Horizontal fine alignment screw
- E. Vertical crude alignment tightening screw
- F. Vertical fine alignment tightening screw
- G. Horizontal crude alignment tightening screw
- H. Horizontal fine alignment tightening screw

**Figure 5-4: Detector and Tilt Mount Assembly Using Lower Mounting Access**

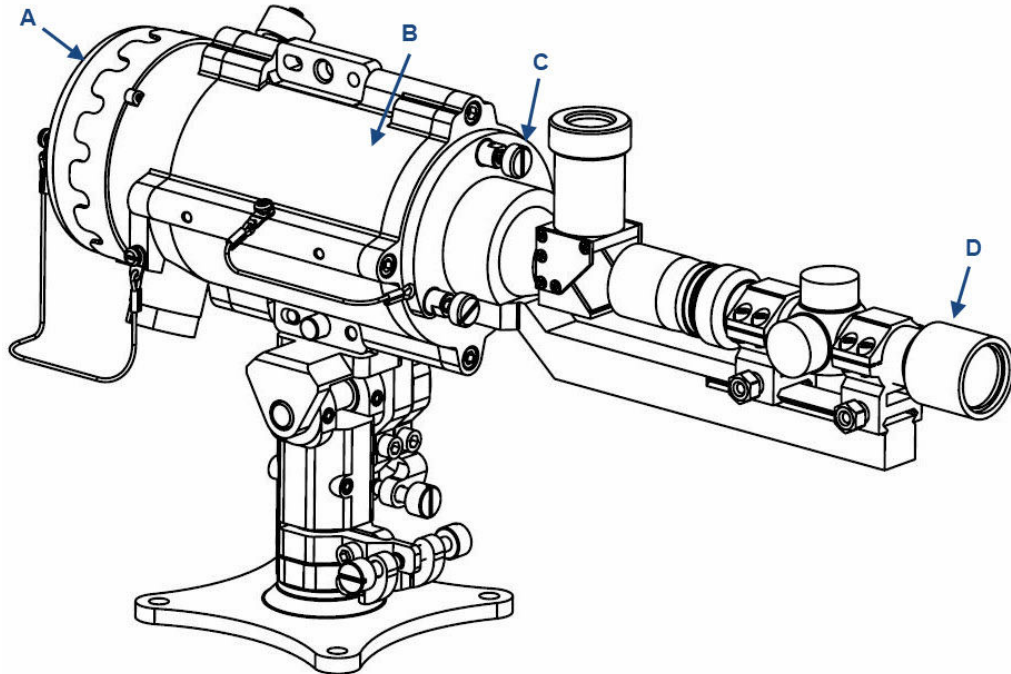

- A. Back cover
- B. Detector
- C. Alignment tool tightening bolt
- D. Alignment tool

**Table 5-4: Tilt Mount Kit**

Item	Quantity	Type / model
Tilt mount	1	N/A
Screw	1	M10 x 1.5
Spring washer	1	No. 10

**Prerequisites**

Prior to mounting the tilt mount to a stable surface, verify that the line of site is unobstructed and corresponds to the detector's installation distance.

**Procedure**

1. Place the tilt mount holding plate in its designated location and secure it with four fasteners through four holes with diameters of 0.3-in. (8.5 mm).

**NOTICE**

Skip this step if the tilt mount is already installed.

Removing the detector for maintenance purposes does not require removing the tilt mount.

2. Place the detector with its conduit/cable inlets pointing downwards on the detector holding plate of the tilt mount.
3. Secure the detector with M10 x 1.5 screws with number M10 spring washers.
4. Secure the detector to the tilt mount using hex key number 7 for M10 x 1.5 screws.
5. Repeat steps [Step 1](#) through [Step 4](#) to install the source.

## 5.8 Wire detector

To install the detector wiring:

**Figure 5-5: Detector with Cover Removed**

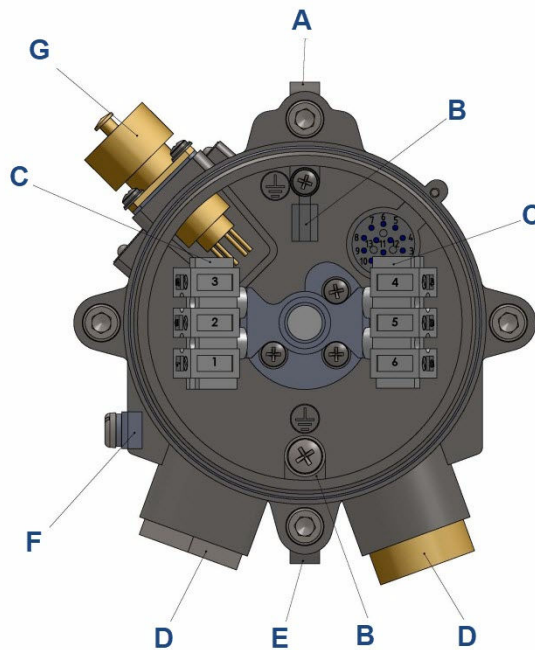

- A. Housing
- B. Internal earth connection
- C. Terminal board
- D. Inlet conduit
- E. Detector holding plate
- F. Earth terminal
- G. Connection to Field Communicator

### Procedure

1. Release the back cover secure bolt and open the detector back cover.
2. Remove the protective plug mounted on the detector conduit/cable entry inlet.
3. Pull the wires through the detector inlet.



4. Use a ¾-in.-14 national pipe thread (NPT) or M25 x 1.5 explosion-proof conduit connection/cable gland to assemble the cable/explosion-proof conduit to the detector.
5. Connect the wires to the required terminals according to the wiring diagram. See [Wiring configurations](#).
6. Connect the grounding wire to the ground screw outside the detector. The detector must be well grounded to earth ground.
7. Place and secure the detector cover by screwing the cover and securing it using the secure bolt.

## 5.9 Wiring to detector terminals

The detector has six wiring terminals. [Table 5-5](#) describes the function of each electrical terminal of the detector.

**Table 5-5: Wiring Options**

Terminal number	Function
1	Power +24 Vdc
2	Return -24 Vdc
3	0-20 mA (input)
4	0-20 mA (output)
5	RS-485 (+)
6	RS-485 (-)

## 5.10 Flash source wiring

### 5.10.1 Install flash source wiring

To install the wiring:

**Figure 5-6: Source with Cover Removed**

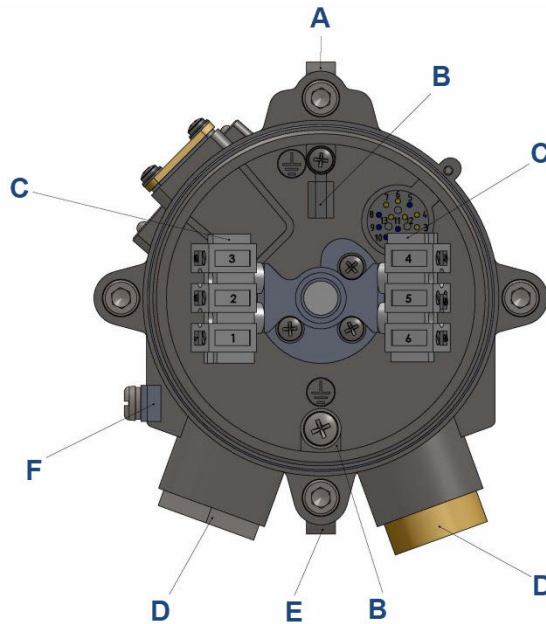

- A. Housing
- B. Internal earth connection
- C. Terminal board
- D. Inlet conduit
- E. Detector holding plate
- F. Earth terminal

#### Procedure

1. Release the back screw bolt and open the source back cover.
2. Remove the protective plug mounted on the source conduit/cable entry inlet; pull the wires through the source inlet.
3. Use a  $\frac{3}{4}$ -in.-14 national pipe thread (NPT) or M25 x 1.5 explosion-proof conduit connection/cable gland to assemble the cable/explosion-proof conduit to the detector.
4. Connect the wires to the required terminals according to the wiring diagram. See [Wiring to source terminals](#) and [Wiring configurations](#).
5. Connect the grounding wire to the ground screw outside the detector. The source must be well grounded to earth ground.

6. Place and secure the source back cover by screwing the cover and securing the back screw bolt.

## 5.10.2 Wiring to source terminals

The source contains six wiring terminals.

**Table 5-6: Flash Source Wiring Options**

Terminal number	Function
1	Power + 24 Vdc
2	Return - 24 Vdc
3	Not used
4	Not used
5	RS-485 (+)
6	RS-485 (-)

## 5.11 Align detector

Use the alignment tool to perform full alignment.

Align the detector in two stages: crude alignment and fine alignment.

The alignment tool includes a periscope that consists of a prism and an ocular located vertical to the alignment tool assembly. This allows you to look into the opposite unit perpendicularly to the alignment when access from the rear of the unit is impossible. For installations where rear access is possible, you don't need to install the periscope. In this case, you can remove it by releasing the periscope fastening screw.

### NOTICE

Prior to installing the alignment tool, verify that the alignment tool and its sight mounting are free from any dirt to ensure proper alignment according to factory calibration. Do not attempt to change any factory calibration at the alignment tool or its mounting.

To align the detector (see [Figure 5-3](#) and [Figure 5-4](#)):

1. Make sure that the detector and flash source are installed properly. [Installation](#) provides installation instructions.
2. Remove the front shield using the two captive screws.
3. Install the alignment tool assembly on the detector/source front.
4. Fasten the alignment tool with fastening screws.

### 5.11.1 Perform crude alignment

#### Prerequisites

Use a ¼-in. Allen screwdriver for all alignment screws.

### Procedure

1. Loosen the horizontal lock screws.
2. Approximately aim the source horizontally towards the detector.
3. Tighten the horizontal lock screw adjacent to the plate.
4. Loosen the vertical lock screws.

#### **⚠ CAUTION**

If the detector is not properly supported when the lock screws are loosened, it could fall and get damaged.

Support the detector when loosening the vertical lock screws.

5. Approximately aim the source vertically towards the detector.
6. Tighten the outer vertical lock screw.
7. Repeat this process for the detector.

## 5.11.2 Perform fine alignment

Refer to [Figure 5-4](#) to see the detector with the alignment tool installed.

### Procedure

1. Remove the front shield and mount the alignment tool on the front of the source using the three screws.  
The alignment tool is supplied in the commissioning kit.
2. Aim the source towards the detector within the horizontal access.
3. Aim the alignment tool to the center of the front window of the detector or source.
4. Tighten the outer horizontal lock screw.
5. Aim the vertical axis.
6. Tighten the inner vertical lock screw.
7. Make sure the alignment tool cross is pointing to the detector and source center of the window.
8. Repeat [Step 2](#) through [Step 7](#) to align the detector.
9. Remove the alignment tool.
10. Install the front shield.

### Postrequisites

Once you have completed fine alignment for both the source and detector, you can turn on the power.

**Figure 5-7: View through the Alignment Tool**





## 6 Operation

### 6.1 Open path system operation

Once the system is positioned, it monitors for possible specified gases, automatically sending signals to a standard control panel or a personal computer (PC).

This section describes calibration and operation.

#### NOTICE

Accurate alignment is essential for proper operation of the open path system.

#### Related information

[Installation](#)

### 6.2 Power up

#### ⚠ WARNING

Prior to operating or maintaining the detector, follow [Safety precautions](#).

#### Procedure

1. Ensure that the source and detector are connected to power.
2. Ensure that the 4-20 mA wiring meter is connected to the detector.
3. Power up the system 18 to 32 Vdc.

After sixty seconds, the current meter indicates 4 mA.

#### Postrequisites

After powering up, zero calibrate the system. See [Zero calibrate](#).

## 6.3 Safety precautions

After powering up, the detector requires minimal attention in order to function properly, but note the following:

### ⚠ WARNING

Follow the instructions in this document; refer to the drawings and specifications issued by the manufacturer.

### ⚠ WARNING

Do not open the detector/source housing while power is applied.

### ⚠ WARNING

Disconnect external devices, such as automatic extinguishing systems, before carrying out any maintenance tasks.

## 6.4 Verify signal

Use an RS-485 or HART® Field Communicator to verify the signal in accordance with [Table 6-1](#).

**Figure 6-1: Light-Emitting Diode (LED) Indication Before Zero Calibration**



1. Verify LED indication.
2. Use Winhost or HART® to verify installation parameters.



## 6.4.1 Signal limitation values

**Table 6-1: Maintenance Channels' Limits**

Channel	Installation distance		
	Minimum	Medium	Maximum
Reference	1 V gain 1	1 V gain 2	1 V gain 5
Signal	1 V gain 1	1 V gain 2	1 V gain 5
Ratio	0.6 - 1.4	0.6 - 1.4	0.6 - 1.4
NQRat	0.98 - 1.02		
Lower explosive limit (LEL)	0 LEL x m		
Temperature	Up to 25 °C beyond ambient temperature		
Voltage	32 Vdc > V > 18 Vdc		

**Note**

The installation information refers to the installation distance.

**Minimum** The minimum distance, as defined according to the model number.

**Medium** Half the maximum distance, as defined according to the model number.

**Maximum** The maximum distance, as defined according to the model number.

Figure 6-2: Maintenance Channels' Limits

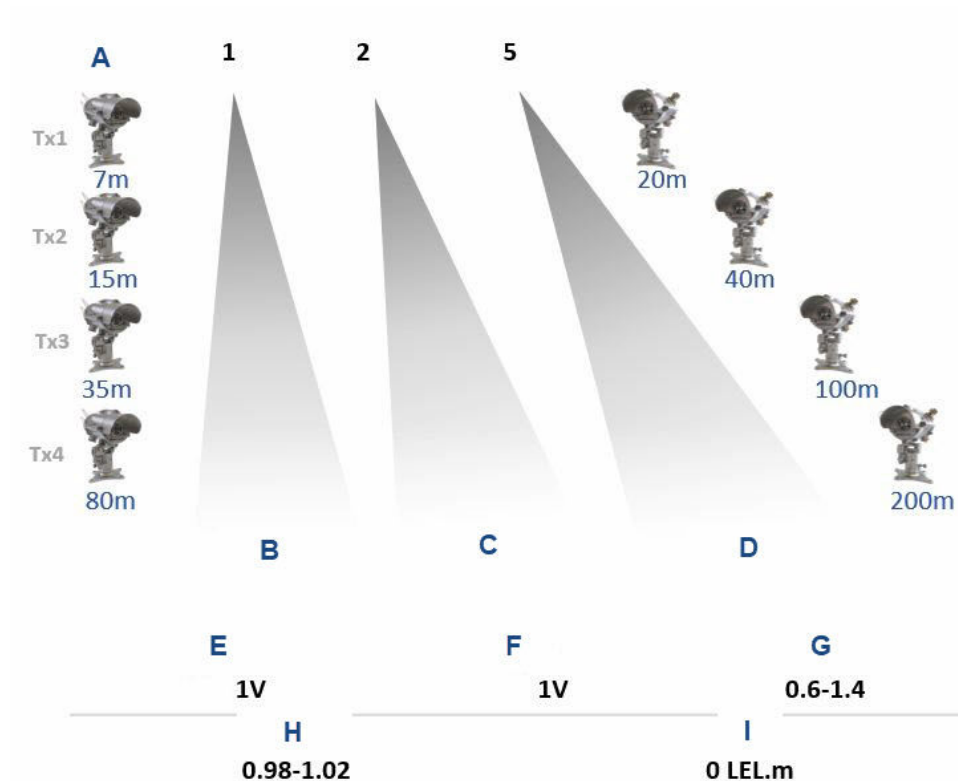

- A. Maximum gain
- B. Minimum range
- C. Median range
- D. Maximum range
- E. Reference minimum
- F. Signal minimum
- G. Ratio
- H. NQ ratio
- I. LEL

## 6.5 Zero calibrate

### Prerequisites

Zero calibrate after any of the following:

- Installation
- Realignment
- Window cleaning
- Any change in detector or source position

**⚠ WARNING**

Only zero calibrate when:

- No combustible gases are present.
- There is a clear path between the source and the detector.
- Weather conditions are clear.

Before zero calibrating, align the detector precisely.

**Figure 6-3: Screens shown when Zero Calibrating with WinHost® Software**

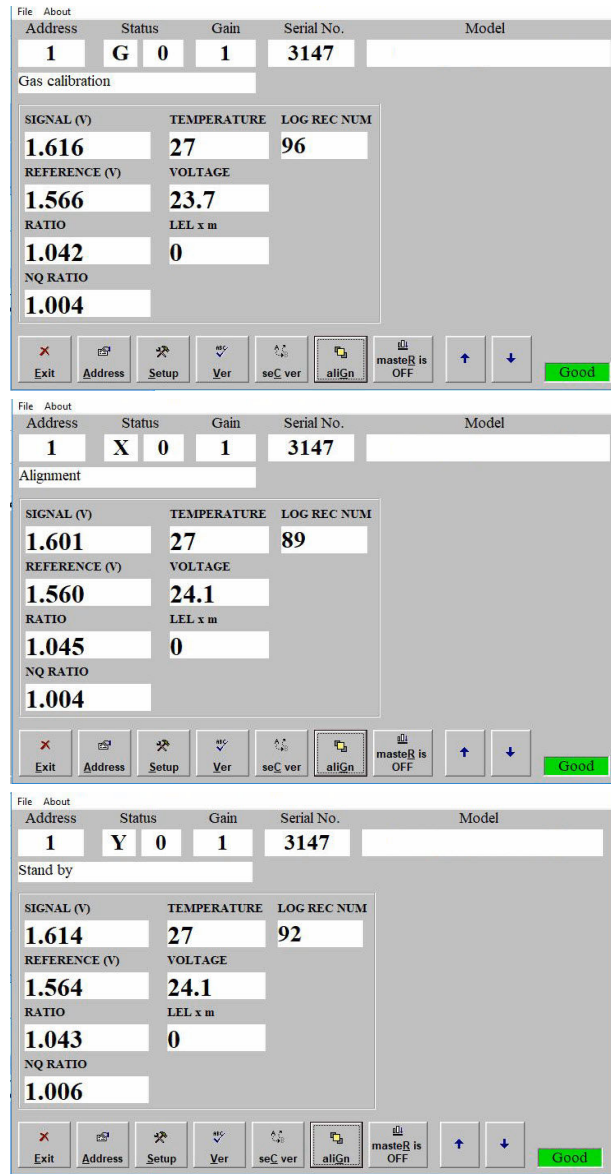

**Figure 6-4: Magnetic Mode Selector**

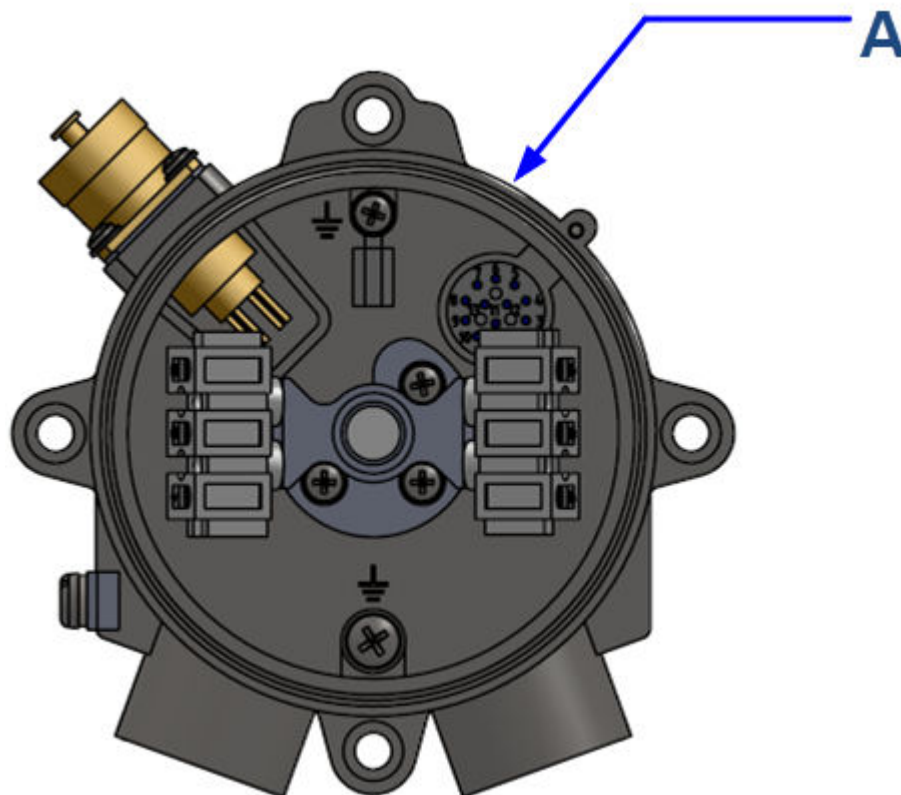

A. Magnet

To switch from each position ([Step 1](#) through [Step 3](#)), use either Winhost, HART®, or RS-485 or move the magnetic mode selector above the magnetic switch (see [Figure 6-4](#)).

#### Procedure

1. Switch from Normal to Alignment mode.
2. Switch from Alignment to Standby mode.
3. Switch from Standby to Zero Calibration mode.  
The 0-20 mA output should now be at 1 mA.
4. Wait up to sixty seconds until it switches to Normal mode.  
The detector reading is now set to Normal. The 0-20 mA output should now indicate 4 mA.

#### Postrequisites

Once zero calibration is complete, refer to [Signal limitation values](#) to verify the installation parameters.

## 6.6 Functional check

Emerson calibrated the Rosemount 935 system at the factory for your specific gas or vapor detection requirements. Use the check filters included in the commissioning kit according to the corresponding calibrating gas to validate correct installation.

The functional check filter is a convenient operational check used to confirm that the response has not changed from previous readings. The filter is not used for calibration, which is unnecessary, nor does it equate to a particular quantity of gas.

### Prerequisites

#### **⚠ WARNING**

Do not allow automatic activation.  
Disconnect any external device that should not be activated during the calibration check.

### Note

This functional verification procedure is for a standard 0-20 mA output. Prior to starting the functional check, verify that the power to the detector is on and that the current of the 0-20 mA channel is stable. Record the reading.

### Procedure

1. Position the functional check filter in front of the detector. Center the functional check filter's window over the viewing window of the detector.  
The check filters are provided in the commissioning kit.

**Figure 6-5: Detector with Functional Check Filter Installed**



2. Wait twenty seconds.
3. Read the 0-20 mA current. Determine the difference between the reading taken with and without the functional check filter.  
The difference is the 0-20 mA current variance.
4. Record the 0-20 mA current variance in the maintenance log book.

**Postrequisites**

If the variance is more than a 30 percent change when compared to the previous check (see delivery form), repeat the alignment.

# 7 Maintenance

## 7.1 General maintenance

The source and detector viewing windows should be kept as clean as possible. The frequency of cleaning operations depends on the existing environmental conditions and the applications used.

## 7.2 Periodic maintenance

Emerson recommends cleaning the optical surfaces periodically.

---

### Note

The frequency of cleaning operations is ultimately dependent upon the existing environmental conditions and the applications used.

---

Things to keep in mind when performing periodic maintenance:

- Proper maintenance will allow the system to retain maximum performance and reliability.
- Keep the optical surfaces of the source and detector viewing window as clean as possible.
- Align the detector each time that the source or the detector has been opened or moved for any reason.
- The signal verification check corroborates the current signals from the flash source compared to that of previous alignments. Emerson recommends performing this check every six to twelve months. Check the signal according to threshold levels.
- Zero calibrate (see [Zero calibrate](#)) every time the detector or source is realigned or the windows are cleaned.

### 7.2.1 Clean optical surfaces

The optical surfaces concerned are the source and detector viewing windows.

#### Procedure

1. Turn off the power to the detector and source.
2. In places where dust or dirt has accumulated on the optical surface, clean the surface with a small, soft bristle brush.
3. Wash the surfaces thoroughly with water and a mild non-abrasive detergent.
4. Thoroughly rinse the glass surface with clean water, ensuring that no residue is left behind.
5. Dry the glass with a clean, dry, soft cloth.
6. Enter the date and the names of the person and company who performed the maintenance service in the maintenance logbook.
7. Turn on power to the detector and source.

8. Verify the signal.
9. Zero calibrate (see [Zero calibrate](#)).
10. Do a functional check (see [Functional check](#)).



# 8 Troubleshooting

## 8.1 Maintenance call

Reference and Signal are below 2 Vdc at gain 9.

Light-emitting diode (LED) = green, blinking, 1 Hz

**Table 8-1: Potential Causes and Resolutions**

Potential cause	Resolution
Poor alignment	Align.
Dirt on the window	Clean the window.
Poor light source	Replace the light source.
Detector fault	Replace or repair the detector.

## 8.2 Detector is in constant Obscuration mode

Host status = O or I

0-20 = 2 mA

Light emitting diode (LED) = yellow, blinking

**Table 8-2: Potential Causes and Resolutions**

Potential cause	Resolution
Poor alignment	Align.
Dirt on the window	Clean the window.
Poor light source	Replace the light source.
Detector fault	Replace or repair the detector.

## 8.3 Detector is in constant Saturation mode

Host status = S

0-20 = 2 mA

Light emitting diode (LED) = yellow, blinking

**Table 8-3: Potential Causes and Resolutions**

Potential cause	Resolution
Installation distance is lower than allowed	Use a different model.
Detector fault	Replace or repair the detector.

## 8.4 Detector is in constant Misalignment mode

Host status = M

0-20 = 2.5 mA

Light emitting diode (LED) = yellow, blinking

**Table 8-4: Potential Causes and Resolutions**

Potential cause	Resolution
Poor alignment	Align.
Detector fault	Replace or repair the detector.

## 8.5 Detector at V fault

Host status = V

0-20 = 1 mA

Light-emitting diode (LED) = yellow, blinking

**Table 8-5: Potential Causes and Resolutions**

Potential cause	Resolution
Low/high input voltage	Check the power supply and installation.
Detector fault	Replace or repair the detector.

## 8.6 Internal fault

Host status = F

0-20 = 1 mA

Light-emitting diode (LED) = yellow, blinking

**Table 8-6: Potential Cause and Resolution**

Potential cause	Resolution
Internal fault	Replace the detector.

## 8.7 NQ Ratio below the permitted limit

Host status = F

0-20 = 1 mA

Light-emitting diode (LED) = yellow, blinking

**Table 8-7: Potential Cause and Resolution**

Potential cause	Resolution
Gas in path	Ensure that the path is clean and the weather conditions are good.

## 8.8 NQ Ratio above the permitted limit

Host status = F

0-20 = 1 mA

Light-emitting diode (LED) = yellow, blinking

**Table 8-8: Potential Cause and Resolution**

Potential cause	Resolution
Poor alignment	Align.

## 8.9 Ratio out of the limit

Host status = F

0-20 = 1 mA

Light-emitting diode (LED) = yellow, blinking

**Table 8-9: Potential Causes and Resolutions**

Potential cause	Resolution
Poor alignment	Align.
Dirt on the window	Clean the window.
Detector fault	Replace or repair the detector.

## 8.10 Source fault

Yellow light-emitting diode (LED) blinking at the source

**Table 8-10: Potential Causes and Resolutions**

Potential cause	Resolution
Low/high input voltage	Check the power supply and installation.
Internal fault	Replace the source.



# A Wiring configurations

Figure A-1: Detector Wiring Terminal

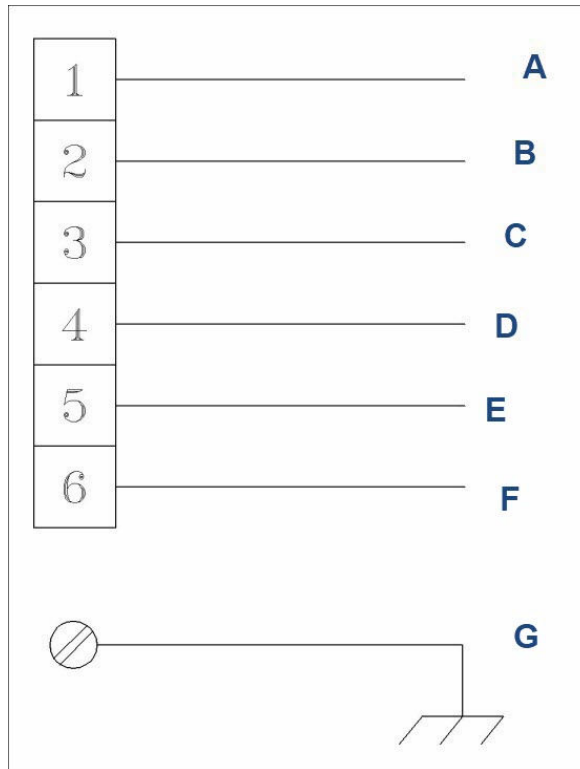

- A. Power (+)  
18 to 32 Vdc
- B. Return (-)
- C. 0-20 mA (input)
- D. 0-20 mA (output)
- E. RS-485 (+)
- F. RS-485 (-)
- G. Ground

**Figure A-2: Source Wiring Terminal**

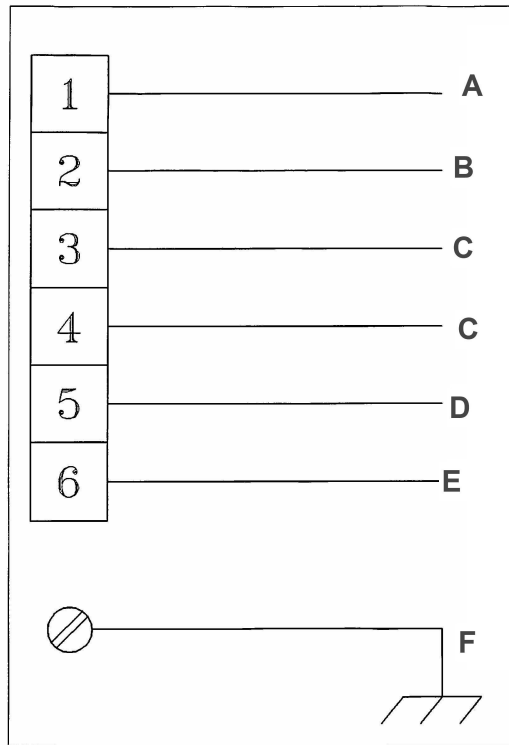

- A. Power (+)  
18 to 32 Vdc
- B. Return (-)
- C. Not used
- D. RS-485 (+)
- E. RS-485 (-)
- F. Ground

Figure A-3: 0-20 mA Sink 4 Wire

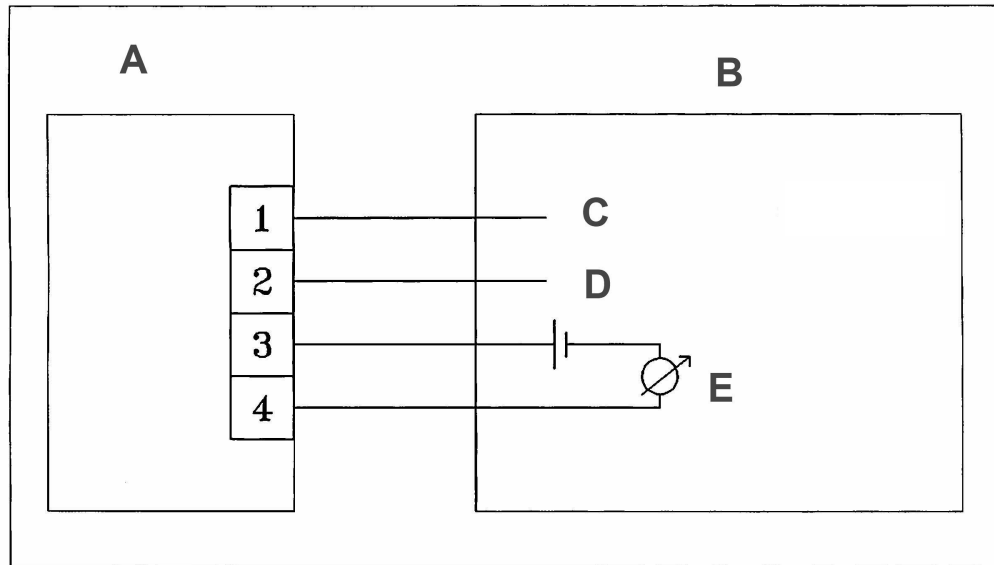

- A. Detector
- B. Controller
- C. Input power: 18-32 Vdc
- D. Return
- E. 0-20 mA meter

**Figure A-4: 0-20 mA Non-Isolated Sink 3 Wire**

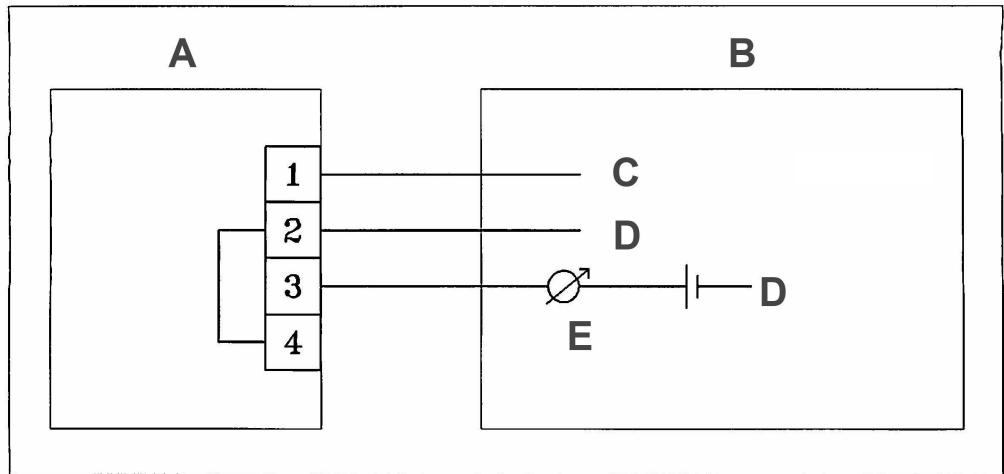

- A. Detector
- B. Controller
- C. Input power: 18-32 Vdc
- D. Return
- E. 0-20 mA meter

**Figure A-5: 0-20 mA Source 3 Wire**

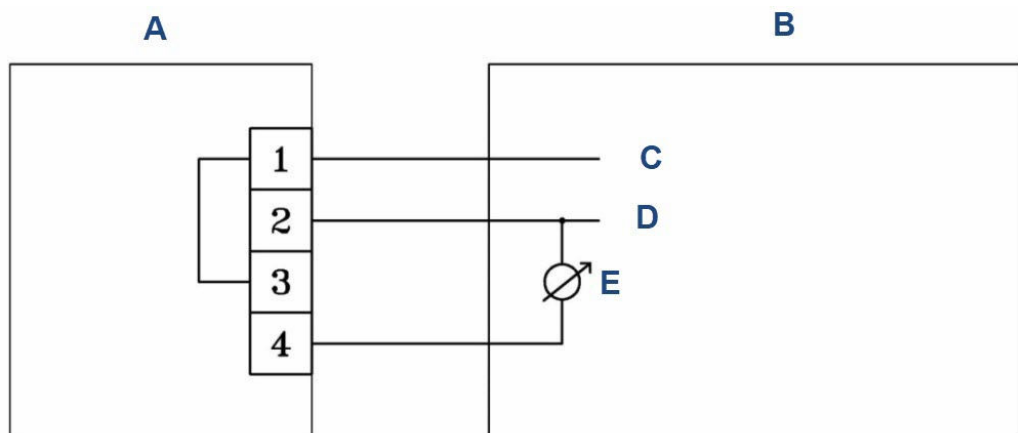

- A. Detector
- B. Controller
- C. Input power: 18-32 Vdc
- D. Return
- E. 0-20 mA meter



## A.1 RS-485 communication network

Using the RS-485 network capability of the Rosemount 935 detector and additional software, it is possible to connect up to 32 detectors in an addressable system with four wires only (two for power and two for communication).

Using repeaters, the number of detectors can be much larger (32 detectors for each repeater) up to 247 on the same four wires. When using the RS-485 network, it is possible to read the detector status (Fault, Warning, and Alarm).

For more details, consult Emerson.

**Figure A-6: RS-485 Networking for Wiring Option 3**

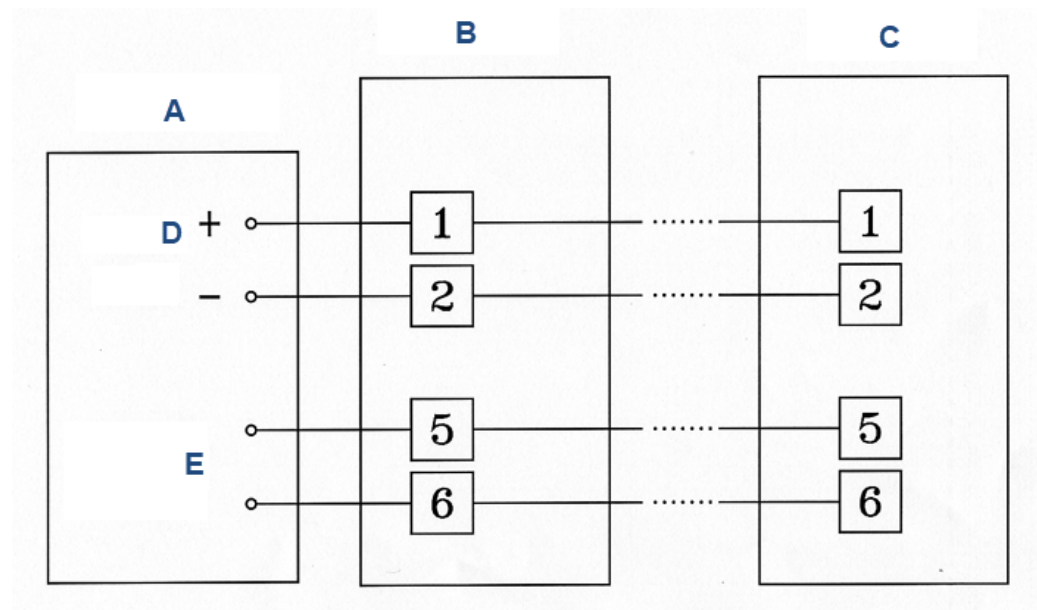

- A. Controller
- B. First detector
- C. Last detector
- D. Power supply
- E. RS-485 computer port



## B SIL-2 features

This appendix details the special conditions to comply with the requirements of EN 61508 for SIL-2.

The Rosemount 935 open path combustible gas detector can be used in low and high demand mode applications. See IEC 61508-4:2010, Chapter 3.5.16.

### B.1 Safety relevant parameters

Type: B

Structure: 1oo1

HFT: 0

Mean time to repair: 72 hours

Ambient temperature: maximum 149 °F (65 °C)

Proof test interval: 52 weeks (1 year)

$\lambda_S = 2056.1$ fit	
$\lambda_D = 1976.1$ fit	
$\lambda_{DU} = 114.8$ fit	
$\lambda_{SD} = 1933.4$ fit	
$\lambda_{DD} = 1861.4$ fit	
SFF = 97%	DC = 94%
$PFD_{avg} = 6.45 \times 10^{-4}$	$PFD_{\%_{SIL2}} = 6.4\%$
$PFH = 1.15 \times 10^{-7}$ 1/h	$PFH_{\%_{SIL2}} = 11.5\%$

### B.2 General conditions for safe use

- The Rosemount 935 should consist only of the approved hardware and software models.
- Consider the application advice and limitations of the Manual. For calibration and maintenance, consider the regional and national regulations.
- The 24 V power supply must fulfill the requirements for PELV/SELV of EN 60950.
- The HART® and RS-485 interfaces are not allowed to be used for the transmission of safety related data.
- The alert conditions according to SIL-2 can be implemented by an alert signal via the 20 mA current loop.
- After installation and configuration, the operator must verify the set-up parameters and check the function of the Rosemount 935.

- The operator must periodically check the transmitter's alarm conditions together with the typical gas calibration checks. The operator must switch the Rosemount 935 **OFF** and **ON**.
- The connected controller must monitor the 0-20 mA signal current for values below 4 mA and above 20 mA.
- The mean time to repair should be 72 hours.

# C Support

For technical support, contact your local Emerson representative or the Rosemount Technical Support department at [safety.csc@emerson.com](mailto:safety.csc@emerson.com).

## C.1 Return of material

To expedite the return of this product, proper communication between the customer and the factory is important.

### Prerequisites

Before returning a product, email [safety.csc@emerson.com](mailto:safety.csc@emerson.com) for a return material authorization (RMA) number.

### Procedure

1. Include the following information when returning equipment:
  - a. RMA number Emerson provided to you
  - b. Company name and contact information
  - c. Purchase order from your company authorizing return
2. Pack all items to protect them from damage and use anti-static bags or aluminum-backed cardboard as protection from electrostatic damage.
3. Mark all packages with *Return* and include the RMA number.
4. Ship all equipment prepaid to the address provided by your Emerson representative.

---

### Important

Ship all equipment prepaid. Emerson will not accept collect shipments.

---



# D Declaration of Conformity

**ROSEMOUNT™**

EU\_R421K

## EU Declaration of Conformity

We, at Rosemount Inc., 6021 Innovation Blvd, Shakopee, MN 55379, United States, declare under our sole responsibility that the product listed below is in conformity with the EC-Type Examination Certificate and with the following directives by application of the listed standards:

### 935 Open Path Combustible Gas Detector

<b>Batch No:</b>	<Batch No.>
<b>Model No:</b>	<Model No.>
SIRA 16ATEX1224X	
	Ex II 2 (2) G D Ex db eb ib [ib Gb] IIB + H2 T4 Gb Ex tb IIIC T135°C Db Ta = -55 °C to +65 °C
Issued by the Notified Body:	CSA Group Netherlands B.V. Utrechtseweg 310 (B42), 6812AR ARNHEM, Netherlands 2813
Surveillance of Quality Assurance Production by:	SGS FIMKO OY, P.O. Box 30 (Särkiniementie 3), 00211 Helsinki, Finland 0598

Provisions of Directive		Number and Date of Issue of Standard
2014/34/EU	ATEX Directive	EN 60079-0:2012+A11:2013, EN 60079-1:2014, EN 60079-7:2015, EN 60079-28:2015, EN 60079-11:2012, EN 60079-31:2014
2014/30/EU	EMC Directive	EN 50270:2015 EN 61000-6-3:2006+AMD1:2010
2011/65/EU	RoHS Directive	EN50581:2012

Approved By



Date:

January 8, 2021

6021 Innovation Blvd, Shakopee, MN 55379, USA | Phone: +1 (866) 347-3427, + 1 (952) 906-8888 |  
Website: [www.emerson.com](http://www.emerson.com); Email: [Safety.CSC@Emerson.com](mailto:Safety.CSC@Emerson.com)

For more information: [www.emerson.com](http://www.emerson.com)

©2021 Emerson. All rights reserved.

Emerson Terms and Conditions of Sale are available upon request. The Emerson logo is a trademark and service mark of Emerson Electric Co. Rosemount is a mark of one of the Emerson family of companies. All other marks are the property of their respective owners.

**ROSEMOUNT™**

