

# Rosemount™ 3490 Controller



## Safety messages

### NOTICE

Read this manual before working with the product. For personal and system safety, and for optimum product performance, ensure you thoroughly understand the contents before installing, using, or maintaining this product. For technical assistance, contacts are listed below:

---

#### Customer Central

Technical support, quoting, and order-related questions.

- United States - 1-800-999-9307 (7:00 am to 7:00 pm CST)
- Asia Pacific- 65 777 8211

#### North American Response Center

Equipment service needs.

- 1-800-654-7768 (24 hours a day — includes Canada)
- Outside of these areas, contact your local Emerson representative.

### ⚠ WARNING

#### **Failure to follow safe installation and servicing guidelines could result in death or serious injury.**

Use the controller only as specified in this Reference Manual.

The controller must be installed, connected, commissioned, operated, and maintained by suitably qualified personnel only, observing national and local requirements that may apply.

The controller must be installed according to the Rosemount 3490 [Product Certifications](#) document.

Before commissioning the controller, ensure that the supply voltage matches the voltage specifications on the main label.

Repair, e.g. substitution of components, etc. may jeopardize safety and is under no circumstances allowed.

#### **Electrical shock could cause death or serious injury.**

Ensure that the controller is not powered when opening the lid and making terminal connections.

If the controller is installed in a high voltage environment and a fault condition or installation error occurs, high voltage may be present on leads and terminals.

---

### ⚠ WARNING

#### **Physical access**

Unauthorized personnel may potentially cause significant damage to and/or misconfiguration of end users' equipment. This could be intentional or unintentional and needs to be protected against.

Physical security is an important part of any security program and fundamental in protecting your system. Restrict physical access by unauthorized personnel to protect end users' assets. This is true for all systems used within the facility.

---

# Contents

<b>Chapter 1</b>	<b>Introduction.....</b>	<b>5</b>
	1.1 Using this manual.....	5
	1.2 Product certifications.....	5
	1.3 Product recycling/disposal.....	5
<b>Chapter 2</b>	<b>Controller overview.....</b>	<b>7</b>
	2.1 Controller functions.....	7
	2.2 Application examples.....	9
	2.3 Components of the controller.....	11
<b>Chapter 3</b>	<b>Installation.....</b>	<b>13</b>
	3.1 Safety messages.....	13
	3.2 Installation considerations.....	13
	3.3 Mount the controller on pipe/wall.....	14
	3.4 Prepare the electrical connections.....	17
	3.5 Connect wiring and power up.....	25
<b>Chapter 4</b>	<b>Configuration.....</b>	<b>31</b>
	4.1 Safety messages.....	31
	4.2 Overview.....	31
	4.3 Configuration tool.....	32
	4.4 Configure the controller using setup wizard.....	32
	4.5 Configure device settings.....	49
	4.6 Configure digital inputs.....	51
<b>Chapter 5</b>	<b>Operation.....</b>	<b>55</b>
	5.1 Safety messages.....	55
	5.2 Display.....	56
	5.3 Keypad.....	58
	5.4 Light emitting diode.....	58
	5.5 Read data from Modbus® register.....	59
	5.6 Security.....	59
<b>Chapter 6</b>	<b>Service and troubleshooting.....</b>	<b>63</b>
	6.1 Safety messages.....	63
	6.2 Diagnostic messages per NAMUR NE 107.....	63
	6.3 Alarm indication selection.....	66
	6.4 Display service menu.....	68
	6.5 Web interface.....	76
	6.6 Service support.....	79
<b>Appendix A</b>	<b>Specifications and reference data.....</b>	<b>81</b>
	A.1 General specifications.....	81
	A.2 Electrical specifications.....	83
	A.3 Mechanical specifications.....	85
	A.4 Environmental specifications.....	86

	A.5 Dimensional drawings.....	88
<b>Appendix B</b>	<b>Configuration parameters.....</b>	<b>91</b>
	B.1 Menu tree.....	91
	B.2 Display.....	94
	B.3 Sensor input.....	96
	B.4 Analog output.....	97
	B.5 Digital inputs.....	99
	B.6 Relay output.....	101
	B.7 Relay mode.....	105
	B.8 Pump modes.....	110
	B.9 Pump control.....	115
	B.10 Alarm conditions configuration.....	119
	B.11 Calculations.....	121
	B.12 Data logging.....	130
<b>Appendix C</b>	<b>Modbus® register table.....</b>	<b>133</b>
	C.1 Introduction.....	133
	C.2 FC04 register area.....	133

# 1 Introduction

## 1.1 Using this manual

The sections in this manual provide information on installing, configuring, operating, and maintaining the Rosemount™ 3490 Controller.

The sections are organized as follows:

[Controller overview](#) provides a description of the controller, information on typical applications, and an introduction to the control function.

[Mechanical installation](#) contains mechanical installation instructions.

[Electrical installation](#) contains electrical installation instructions.

[Configuration](#) provides instructions on configuration of the controller using the display.

[Operation](#) contains operation techniques.

[Service and troubleshooting](#) provides troubleshooting techniques for the most common operating problems.

[Specifications and reference data](#) supplies reference and specification data.

[Configuration parameters](#) provides extended information about the configuration parameters.

## 1.2 Product certifications

See the Rosemount 3490 [Product Certifications](#) document for detailed information on the existing approvals and certifications.

## 1.3 Product recycling/disposal

Recycling of equipment and packaging should be taken into consideration and disposed of in accordance with local and national legislation or regulations.

### **Related information**

[Service support](#)





### Relay control functions

The controller provides up to six freely assignable relay outputs. By default, one relay is a fault relay but can be assigned to a control duty. The other relays are available for controlling pumps or alarms. The controller is pre-programmed with popular pump control routines for wet well and sump control, along with energy saving overrides.

### Digital inputs

There are up to four digital input ports suitable for applications where the controller functionality is linked to other external events. The digital inputs can be individually setup to perform various control actions (e.g. raise an alarm) whenever activated.

### Sensor inputs

There are up to two sensor inputs available for connection of any 4-20 mA or HART<sup>®</sup> sensor, for monitoring of live transmitter level reading.

### Calculations

The controller is pre-programmed with standard tank shapes and flow algorithms to simplify the configuration for calculating volume or flow from the live transmitter level reading. A 20-point programmable look-up table is provided for non-standard applications. In addition, all measurements can be totalized, differenced, and logged.

### Data logging

The Rosemount 3490 provides simple report and documentation handling through logged data, easily accessible and shareable by the controller web interface.

### Modbus<sup>®</sup> TCP/IP communication to host

The Ethernet port can be used for Modbus TCP/IP connection to host systems. By simply connecting the controller to the existing LAN network, communication over Ethernet is established.

**Figure 2-2: Rosemount 3490 Modbus/TCP Communication to Host**

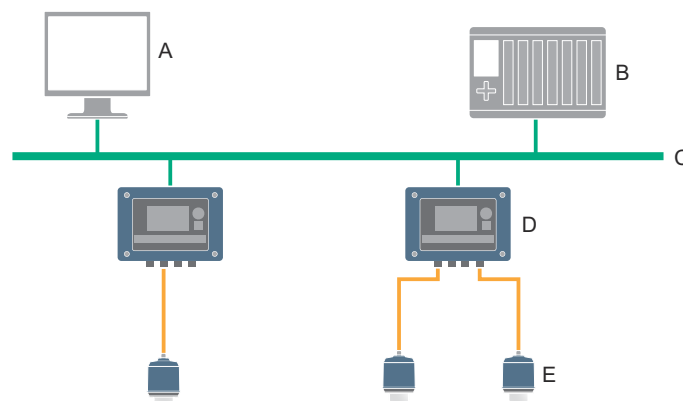

- A. PC
- B. Host
- C. LAN (Local Area Network)
- D. Rosemount 3490 Controller
- E. Rosemount 1208C Level and Flow Transmitter



## 2.2 Application examples

### Level and pump control

Pump stations need accurate measurement and control to ensure an optimal water flow to the next stage of the potabilization process, while also avoiding overflows and pumps from dry-running. Level measurement is essential to ensure a sustainable extraction of water and a sufficient supply of water to the next phases of the potabilization process.

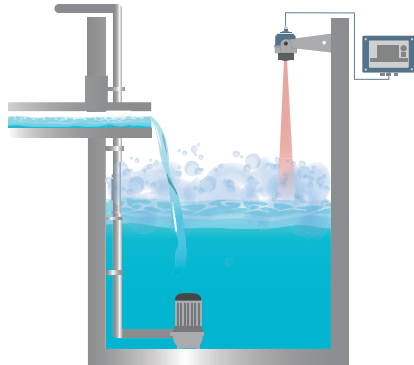

### Open channel flow

Open-air channels transport water from a water source to a water plant where it will be processed. Flow monitoring in open channels is important to know the amount of water that is flowing to comply with regulations and avoid flooding.

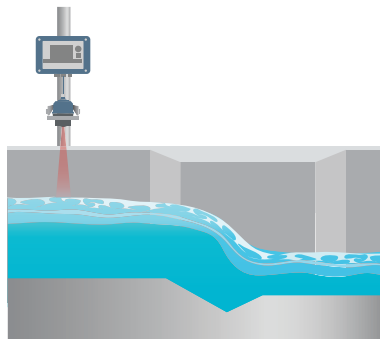

### Differential level

In the screening process level measurement is necessary to monitor the level of water in the different parts of the screen, which will determine when to start the cleaning of the sieve.

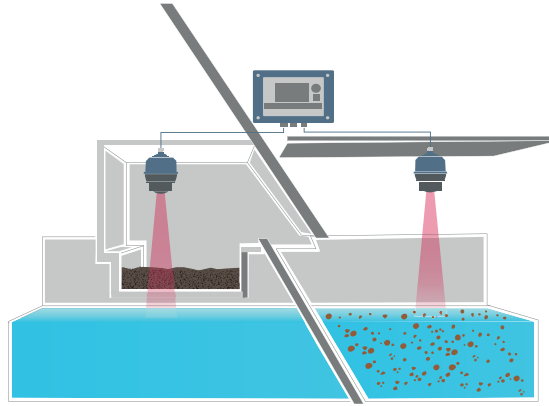

### Tank volume

Storage tanks are used in water processes to store chemical substances, which are needed to treat the water. Level measurement is necessary to monitor, optimize chemical dosing, and avoid overflowing.

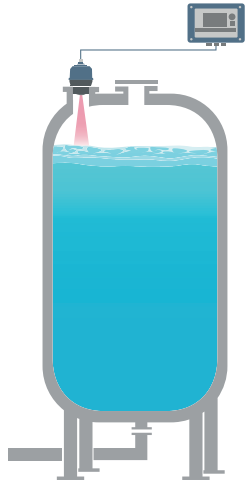

## 2.3 Components of the controller

Figure 2-3 shows the various parts of the controller.

Figure 2-3: Rosemount 3490 Components

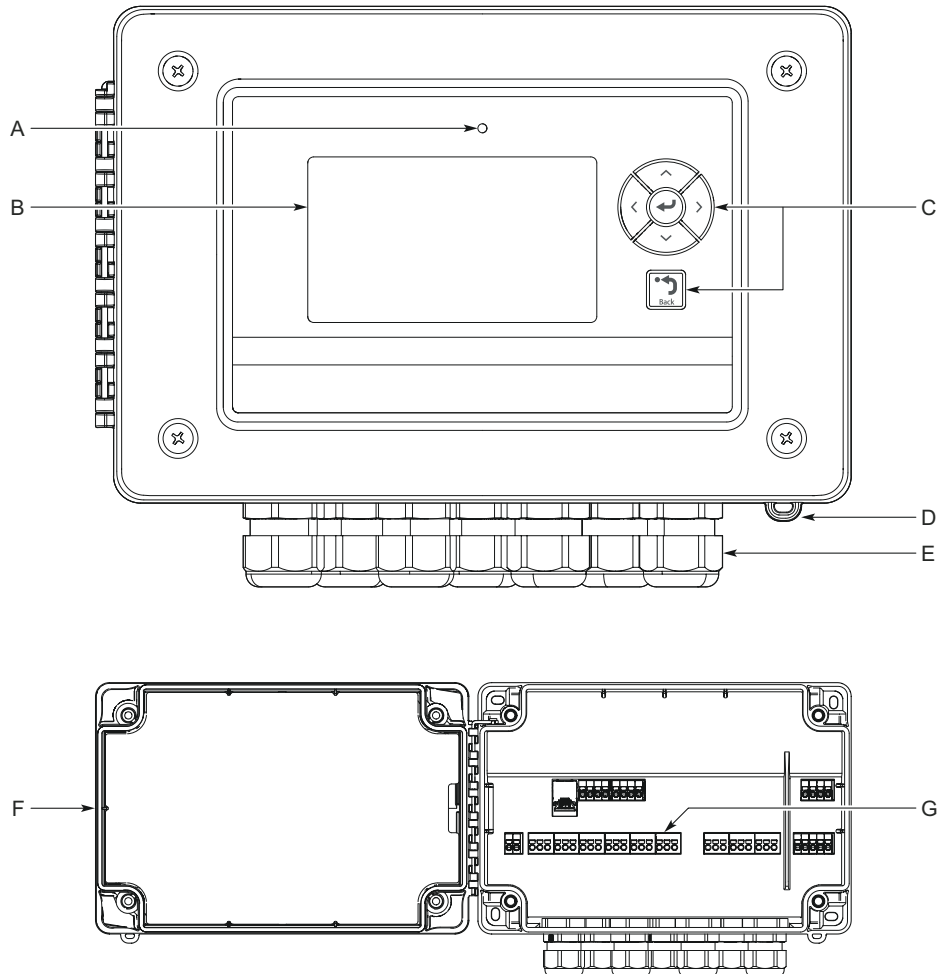

- A. Light Emitting Diode (LED) for status and error information
- B. Display
- C. Keypad
- D. Sealing arc
- E. Cable entries
- F. Lid
- G. Terminal board and ports



## 3 Installation

### 3.1 Safety messages

Instructions and procedures in this section may require special precautions to ensure the safety of the personnel performing the operations. Information that potentially raises safety issues is indicated by a warning symbol (). Refer to the following safety messages before performing an operation preceded by this symbol.

#### **WARNING**

**Failure to follow safe installation and servicing guidelines could result in death or serious injury.**

Use the controller only as specified in this Reference Manual.

The controller must be installed, connected, commissioned, operated, and maintained by suitably qualified personnel only, observing national and local requirements that may apply.

The controller must be installed according to the Rosemount 3490 [Product Certifications](#) document.

Before commissioning the controller, ensure that the supply voltage matches the voltage specifications on the main label.

Repair, e.g. substitution of components, etc. may jeopardize safety and is under no circumstances allowed.

**Electrical shock could cause death or serious injury.**

Ensure that the controller is not powered when opening the lid and making terminal connections.

If the controller is installed in a high voltage environment and a fault condition or installation error occurs, high voltage may be present on leads and terminals.

#### **CAUTION**

**Pollution protection**

Ensure that during installation or maintenance no moisture or dirt can get inside the instrument.

To maintain the housing protection, ensure that the housing lid is closed during operation and locked, if necessary.

### 3.2 Installation considerations

#### General

- The controller is classified type A in accordance with European EMC directive 2014/30/EU. To ensure electro-magnetic compatibility, in any member country, the controller should not be installed in a residential area.
- Supply circuits must be limited to Overvoltage category II, according to IEC 60664-1.
- Ambient temperature range: -40 to +140 °F (-40 to +60 °C)<sup>(1)</sup>

### Mounting and installation

- Do not mount the controller on a structure that is subject to vibration, or in a position where damage may be caused by impact, thermal stress or liquid ingress.
- Do not mount the controller in a position where it might come into contact with aggressive substances, e.g. acidic liquids or gases that may attack metals or solvents that may affect polymeric materials.
- The controller housing is rated IP66/IP67 and Type 4X. It is suitable for mounting outside, but this should be above any flood level, away from any overflow path, and away from direct sunlight.
- The mass of the unit is 3.7 lb (1.7 kg). To conform with safety requirements, the wall on which the unit is mounted should be capable of supporting four times this weight.
- Do not mount the controller in a position where it might be exposed to mechanical damage or friction. The controller can withstand an impact of maximum 2 Joule, level of protection: IK07.

### Wiring

- Ensure that cable glands and connections to the controller are done in accordance with local and national standards. To maintain the type 4X rating of the enclosure, type 4X connections must be used.
- Cable runs should be separate from any high voltage or mains cables to avoid crosstalk or interference.
- A switch or circuit-breaker must be included in the installation, suitable located and easily reached. It must be marked as the disconnecting device for the controller.
- Wires for mains connection should be tied together to prevent from accidental loosening.
- Field wiring shall be rated for 38 °F (21 °C) above maximum ambient temperature.

### Maintenance

- To ensure the controller functionality, periodic visual inspection is recommended for:
  - Secure mounting
  - No mechanical damages or corrosion
  - Worn or otherwise damaged cables

## 3.3 Mount the controller on pipe/wall

The mounting instruction includes the wall and pipe mounting kit and the weather protection accessories. Both items are ordered separately, refer to the [Rosemount 3490 Product Data Sheet](#).

---

(1) Display reading: -4 to +140 °F (-20 to +60 °C).

**Procedure**

1. Mount the bracket on the pipe/wall.

On pipe:

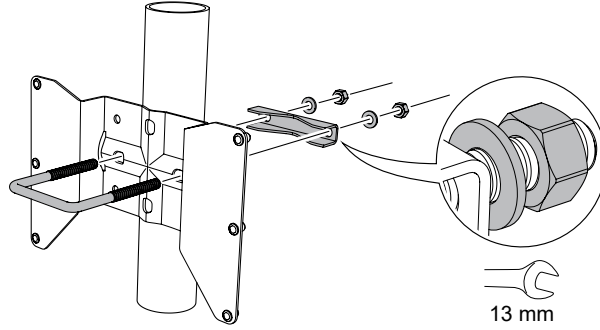

or

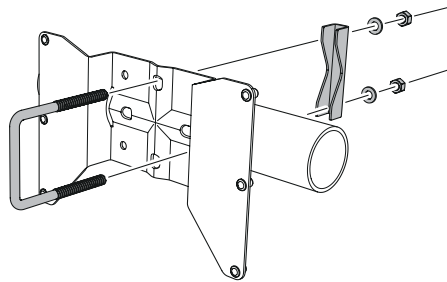

On wall:

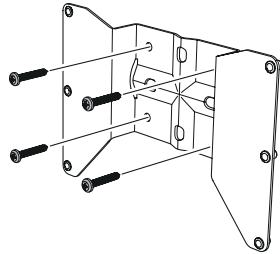

2. Mount the weather protection, using the enclosed screws.

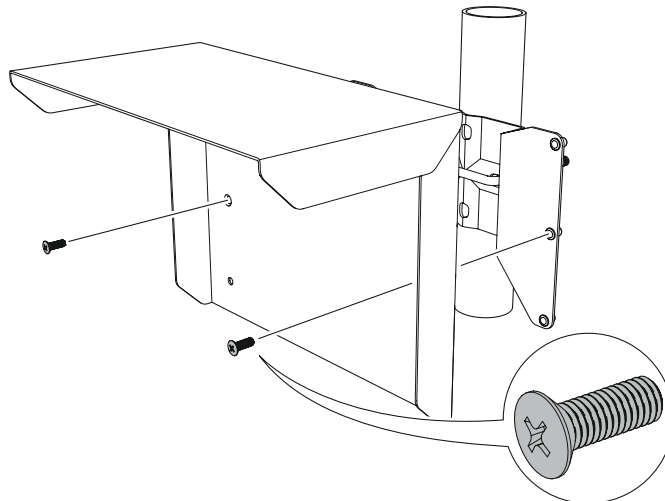

3. Loosen the four screws on the lid.

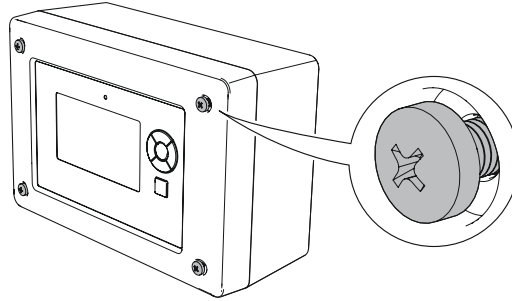

4. Mount the controller.

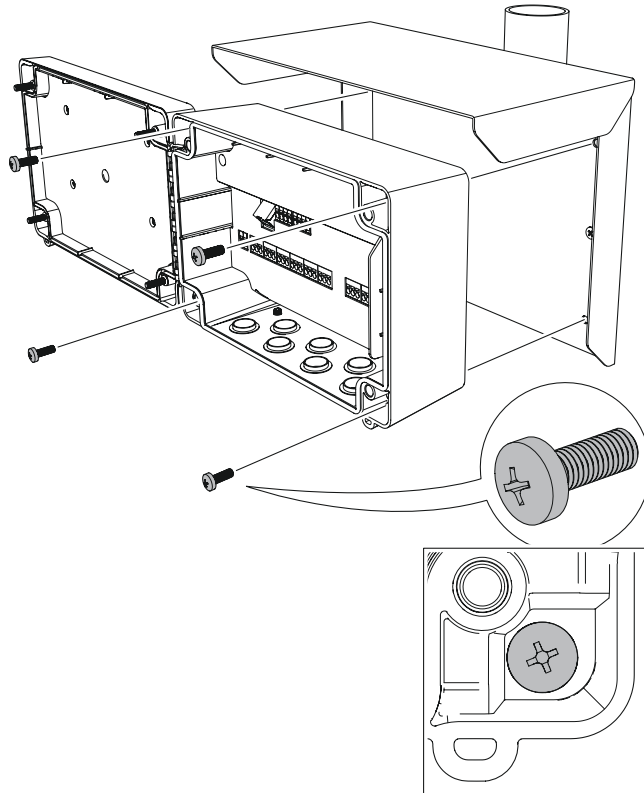

5. Close the lid and tighten the four screws to torque 0.7 lb-ft (1 Nm).

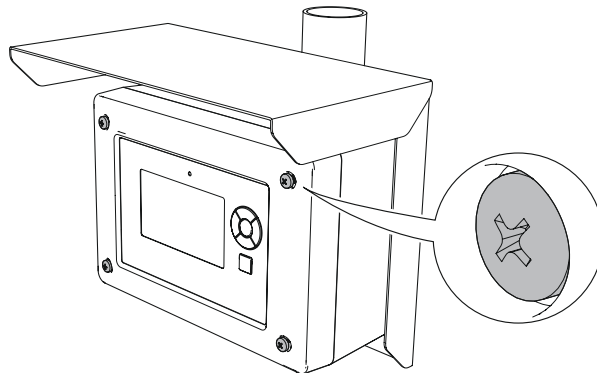



**Related information**

[Bracket hole pattern](#)

## 3.4 Prepare the electrical connections

### 3.4.1 Cable selection

The cable diameter must be suitable for the cable gland used to ensure the seal effect of the cable gland (IP protection).

### 3.4.2 Cable glands

The controller housing has seven entries for M20 cable glands.

**Table 3-1: Tightening Torque for Cable Glands, lb-ft (Nm)**

Item	Cable gland	Ethernet cable gland <sup>(1)</sup>
Cable gland	3.0 (4.0)	3.3 (4.5)
Top nut	2.2 (3.0)	3.3 (4.5)

*(1) Only supplied with accessory gland kit.*

**Table 3-2: Cable Diameter for Glands, in. (mm)**

	Cable gland	Ethernet cable gland <sup>(1)</sup>
Cable Ø	0.16-0.51 (4-13)	0.27 (6.9)

*(1) Only supplied with accessory gland kit.*

### 3.4.3 Conduit hubs

The controller can be installed with conduit hubs. The conduit hub must be installed with a M20 to ½ NPT adapter mounted to the support plate. The adapter is available as accessories.

**Table 3-3: Tightening Torque for Adapter supplied by Emerson, lb-ft (Nm)**

Item	Torque
Adapter, M20 thread	5.2 (7.0)

### 3.4.4 Terminal connection type

Spring loaded terminals

### 3.4.5 Conductors

Ensure that you use cables suitable for the terminal blocks.

**Table 3-4: Cables Suitable for Rosemount 3490 Terminal Blocks**

Conductor connection	Maximum (mm <sup>2</sup> )	AWG
Solid	4	12
Flexible	2.5	13
Flexible, Ferrule with plastic collar	1.5	16

**Figure 3-1: Conductor Stripping Length and Cross-Sectional Area**

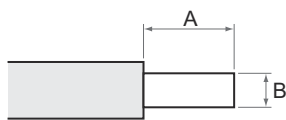

- A. Stripping length: 0.4 in. (10 mm)
- B. Cross-sectional area, see [Table 3-4](#)

### 3.4.6 Power supply

The Rosemount 3490 accepts supply voltage 100-240 Vac 50/60 Hz (-15% to +10%)

### 3.4.7 Power consumption

Maximum 12 W

### 3.4.8 Grounding

Make sure grounding is done according to national and local electrical codes. Failure to do so may impair the protection provided by the equipment. Grounding requirements are dependent on application type:

**Shielded cables**

- Connect cable shield to terminal 42 (terminal 71 for sensor input 2)
- Connect terminal 41 to instrument earth/ground point

**Unshielded cables**

Grounding is not necessary for unshielded sensor cables. Leave terminals 41, 42 and 71 unconnected.

### 3.4.9 Protective earth

The metal support plate should always be grounded in accordance with national and local electrical codes. Failure to do so may impair the protection provided by the equipment. The most effective grounding method is direct connection to earth ground with minimal impedance. There is a grounding screw connection on the metal support plate.

### 3.4.10 Sensor wire cross-section

Appropriate cross-sectional area of wires must be used in order to prevent a too high voltage drop to the connected sensor. Use 0.75 mm<sup>2</sup> to 2.5 mm<sup>2</sup> (18 AWG to 13 AWG) in order to minimize the voltage drop.

### 3.4.11 Terminal board and ports

Figure 3-2: Ports and Terminals - Rosemount 3490A

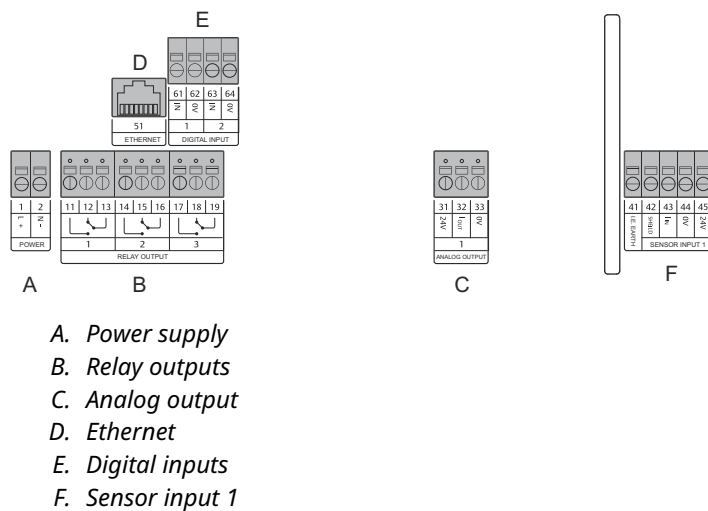
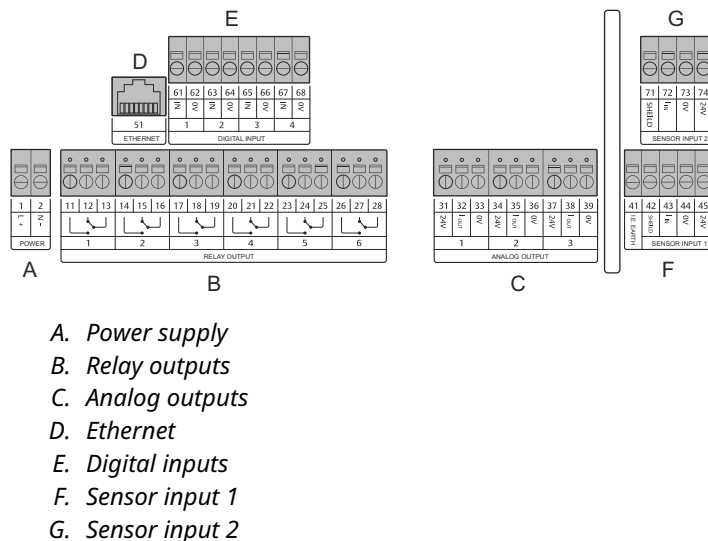

Figure 3-3: Ports and Terminals - Rosemount 3490C



**Table 3-5: Terminal Assignment - Rosemount 3490A**

Terminal	Designation	Function
1	L +	Power, Line
2	N -	Power, Neutral
11	NO 1	Relay output 1, normally open
12	NC 1	Relay output 1, normally closed
13	COM 1	Relay output 1, common
14	NO 2	Relay output 2, normally open
15	NC 2	Relay output 2, normally closed
16	COM 2	Relay output 2, common
17	NO 3	Relay output 3, normally open
18	NC 3	Relay output 3, normally closed
19	COM 3	Relay output 3, common
31	24V	Analog output 1, 24 V
32	I <sub>OUT</sub> 1	Analog output 1, I <sub>OUT</sub>
33	0V	Analog output 1, 0 V
41	I.E. Earth	Instrument earth
42	Shield	Sensor input 1, shield
43	I <sub>IN</sub> 1	SensorInput 1, I <sub>IN</sub>
44	0V	Sensor input 1, 0 V
45	24V	Sensor input 1, 24 V
51	Ethernet	Ethernet <sup>(1)</sup>
61	IN 1	Digital input 1, IN
62	0V	Digital input 1, 0 V
63	IN 2	Digital input 2, IN
64	0V	Digital input 2, 0 V

*(1) In case the controller is connected to a Local Area Network (LAN) via Modbus TCP, ensure the connection is secure and no unauthorized personnel can grant access.*

**Table 3-6: Terminal Assignment - Rosemount 3490C**

Terminal	Designation	Function
1	L +	Power, Line
2	N -	Power, Neutral
11	NO 1	Relay output 1, normally open
12	NC 1	Relay output 1, normally closed
13	COM 1	Relay output 1, common
14	NO 2	Relay output 2, normally open
15	NC 2	Relay output 2, normally closed
16	COM 2	Relay output 2, common
17	NO 3	Relay output 3, normally open
18	NC 3	Relay output 3, normally closed
19	COM 3	Relay output 3, common
20	NO 4	Relay output 4, normally open
21	NC 4	Relay output 4, normally closed
22	COM 4	Relay output 4, common
23	NO 5	Relay output 5, normally open
24	NC 5	Relay output 5, normally closed
25	COM 5	Relay output 5, common
26	NO 6	Relay output 6, normally open
27	NC 6	Relay output 6, normally closed
28	COM 6	Relay output 6, common
31	24V	Analog output 1, 24 V
32	I <sub>OUT</sub> 1	Analog output 1, I <sub>OUT</sub>
33	0V	Analog output 1, 0 V
34	24V	Analog output 2, 24 V
35	I <sub>OUT</sub> 2	Analog output 2, I <sub>OUT</sub>
36	0V	Analog output 2, 0 V
37	24V	Analog output 3, 24 V
38	I <sub>OUT</sub> 3	Analog output 3, I <sub>OUT</sub>
39	0V	Analog output 3, 0 V
41	I.E. Earth	Instrument earth
42	Shield	Sensor input 1, shield
43	I <sub>IN</sub> 1	SensorInput 1, I <sub>IN</sub>
44	0V	Sensor input 1, 0 V
45	24V	Sensor input 1, 24 V
51	Ethernet	Ethernet <sup>(1)</sup>
61	IN 1	Digital input 1, IN

**Table 3-6: Terminal Assignment - Rosemount 3490C (continued)**

Terminal	Designation	Function
62	0V	Digital input 1, 0 V
63	IN 2	Digital input 2, IN
64	0V	Digital input 2, 0 V
65	IN 3	Digital input 3, IN
66	0V	Digital input 3, 0 V
67	IN 4	Digital input 4, IN
68	0V	Digital input 4, 0 V
71	Shield	Sensor input 2, shield
72	I <sub>IN</sub> 2	Sensor input 2, I <sub>IN</sub>
73	0V	Sensor input 2, 0 V
74	24V	Sensor input 2, 24 V

- (1) *In case the controller is connected to a Local Area Network (LAN) via Modbus TCP, ensure the connection is secure and no unauthorized personnel can grant access.*

### 3.4.12 Wiring diagrams

#### Sensor input connections

Loop-powered sensors are connected as shown in [Figure 3-4](#).

**Figure 3-4: Sensor Input - Loop Powered**

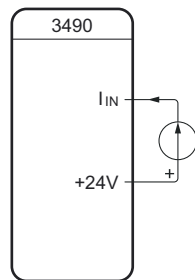

See [Figure 3-5](#) for an example where the Rosemount 1208C is connected to the Rosemount 3490C sensor input 1.

**Figure 3-5: Example: 1208C Connected to 3490C Sensor Input 1**

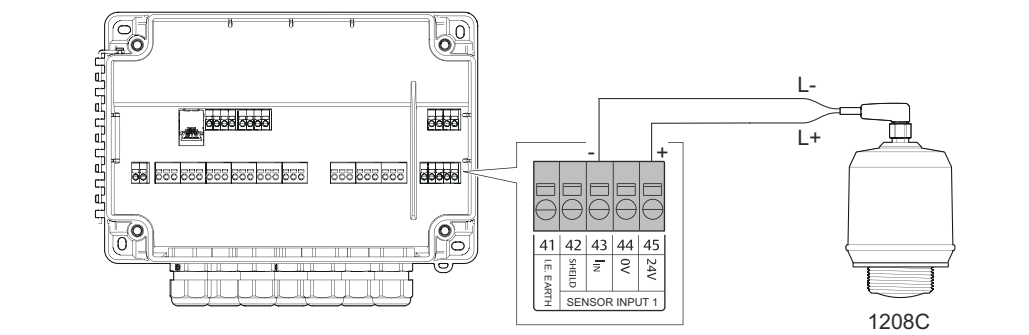

[Figure 3-6](#) and [Figure 3-7](#) displays the connection of self-powered sensors, 3-wire and 4-wire.

**Figure 3-6: Sensor Input - Self Powered, 3-Wire, Safe Area**

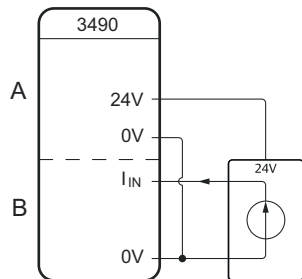

- A. Analog output
- B. Sensor input

**Figure 3-7: Sensor Input - Self Powered, 4-Wire, Safe Area**

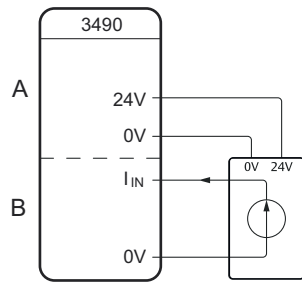

- A. Analog output
- B. Sensor input

### Analog output connections

The analog output may be connected in internally-powered or loop-powered mode. In loop-powered mode, an external power source is required.

**Figure 3-8: Analog Output**

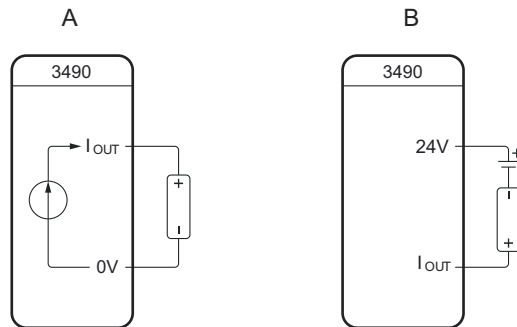

- A. Internal power
- B. Loop power



## Relay output connections

The controller relay outputs are available for normally closed and normally open relay connections.

Limit range: 250 Vac 8 A/24 Vdc 8 A resistive load.

**Figure 3-9: Relay Output**

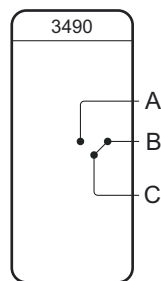

- A. Normally open
- B. Normally closed
- C. Common

## Digital input connections

The digital potential-free contact inputs are connected as shown in [Figure 3-10](#). Limit range: Output voltage 14 V, Output current 6 mA.

**Figure 3-10: Digital Input**

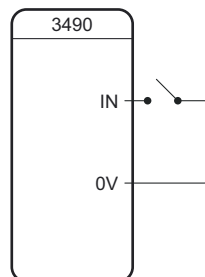

## 3.5

## Connect wiring and power up

### Procedure

1. ⚠ Ensure the power supply is disconnected.

2. Unscrew the four screws on the lid.

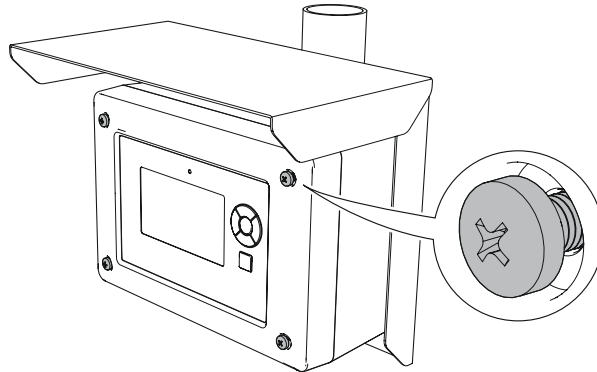

3. Open the lid.

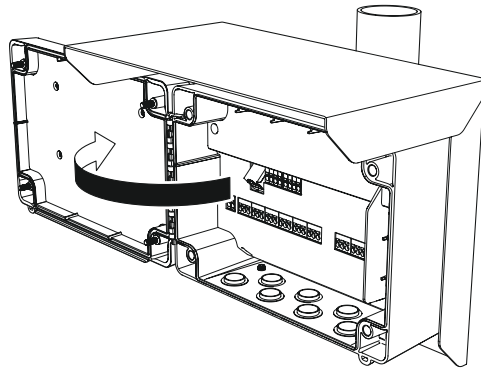

4. Remove the plastic plugs.

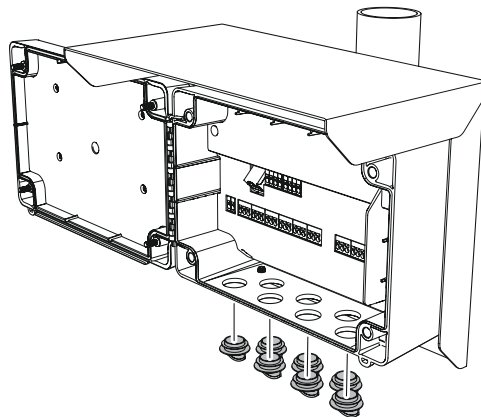

5. Place the support plate into position.

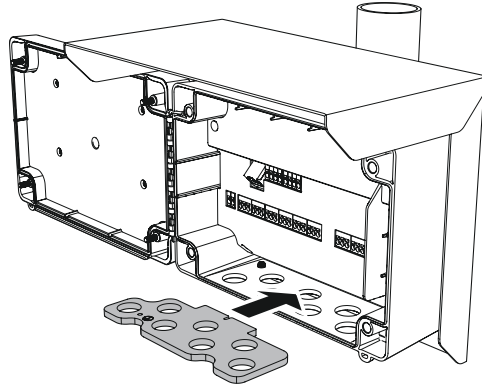

6. Mount the cable glands.

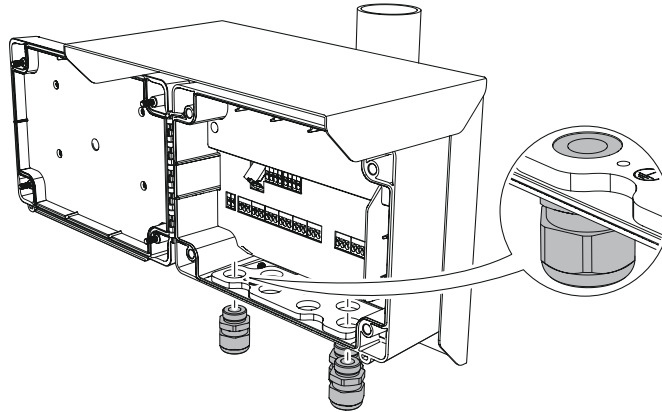

7. Pull the power cable through the cable gland.

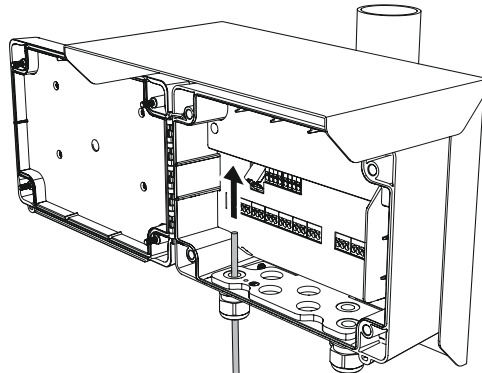

8. Connect the protective earth ground to the support plate with the ring terminal<sup>(2)</sup> and grounding screw (M4) included in the delivery.

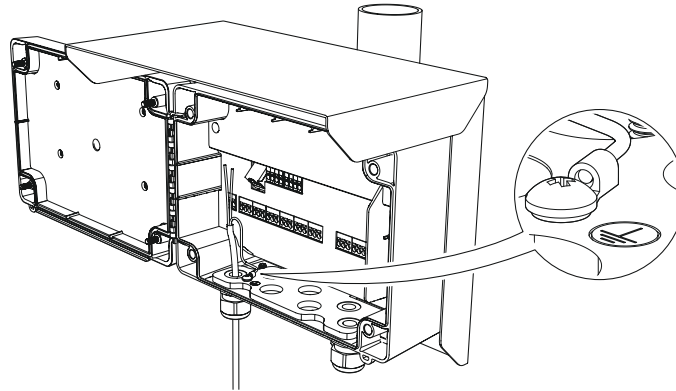

9. Connect the power supply wires to the terminal compartment.

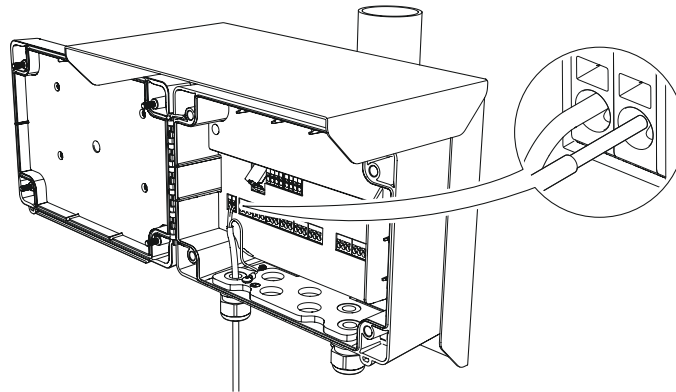

---

**Note**

When connecting a flexible (stranded) conductor, use a small flat head screwdriver to press down and hold the terminal connection open.

---

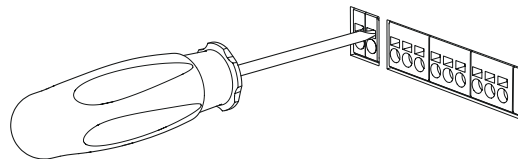

10. Connect the cables to the terminal compartments suitable for your application (see [Prepare the electrical connections](#)).
11. Ensure proper grounding (see [Grounding](#)).

---

<sup>(2)</sup> 14 AWG (2.1 mm<sup>2</sup>) or smaller wire.

12. Tighten the cable glands.

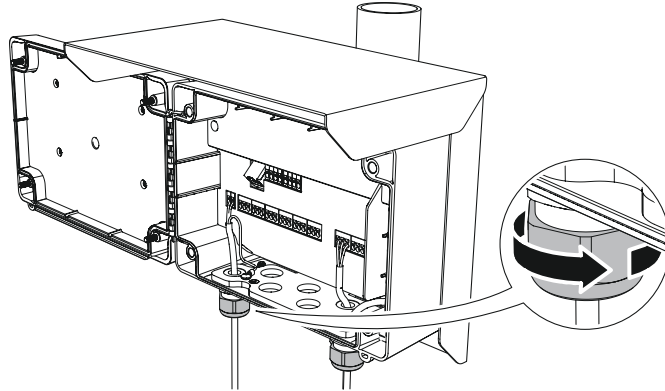

13. Seal any unused port with the enclosed plugs.

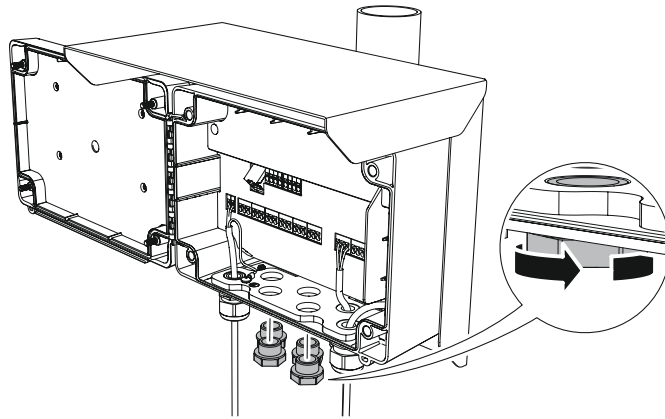

14. Close the lid and tighten the four screws to torque 0.7 lb-ft (1 Nm).

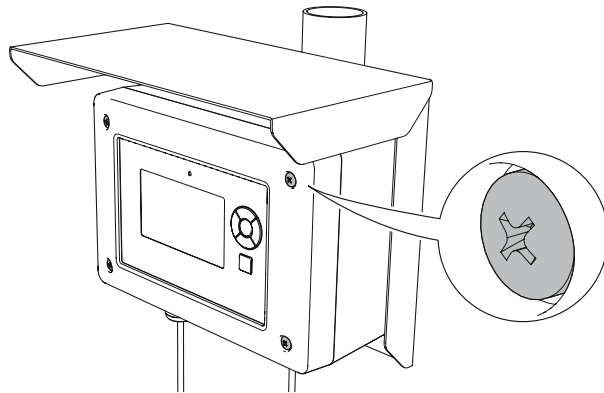

15. Connect the power supply.

During start-up, approximately 30 seconds, the display prompts the following screen:



Once the start-up procedure is finished, the display prompts the following screen:

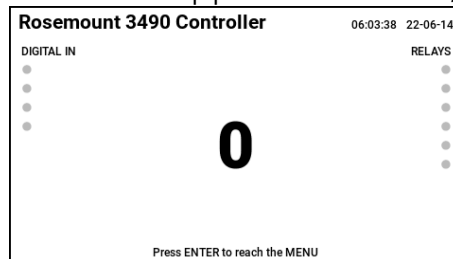

### Postrequisites

The controller is now ready to be configured.

## 4 Configuration

### 4.1 Safety messages

Instructions and procedures in this section may require special precautions to ensure the safety of the personnel performing the operations. Information that potentially raises safety issues is indicated by a warning symbol (). Refer to the following safety messages before performing an operation preceded by this symbol.

#### **WARNING**

**Failure to follow safe installation and servicing guidelines could result in death or serious injury.**

Use the controller only as specified in this Reference Manual.

The controller must be installed, connected, commissioned, operated, and maintained by suitably qualified personnel only, observing national and local requirements that may apply.

The controller must be installed according to the Rosemount 3490 [Product Certifications](#) document.

Before commissioning the controller, ensure that the supply voltage matches the voltage specifications on the main label.

Repair, e.g. substitution of components, etc. may jeopardize safety and is under no circumstances allowed.

**Electrical shock could cause death or serious injury.**

Ensure that the controller is not powered when opening the lid and making terminal connections.

If the controller is installed in a high voltage environment and a fault condition or installation error occurs, high voltage may be present on leads and terminals.

#### **CAUTION**

**Pollution protection**

Ensure that during installation or maintenance no moisture or dirt can get inside the instrument.

To maintain the housing protection, ensure that the housing lid is closed during operation and locked, if necessary.

### 4.2 Overview

This chapter provides information about configuration using the application wizards, and basic settings for the controller.

Appendix [Configuration parameters](#) provides extended information about the configuration parameters.

## 4.3 Configuration tool

The keypad function buttons are used to navigate the menu system where application parameters are configured.

### Related information

[Keypad](#)

## 4.4 Configure the controller using setup wizard

The Rosemount 3490 wizards will setup the majority of applications. Additional changes to configuration parameters can be implemented using the Advanced configuration menu.

The following configuration examples provide a guidance through each application wizard, with specific inputs and outputs stated for each example.

### 4.4.1 Example: Set up a level and pump control application

**Table 4-1: Example Inputs**

Function	Configuration
Level measurement units	Feet
Transmitter bottom reference	22 ft
Sump/lift station working level	20 ft
Number of pumps	2
Pump mode	Duty assist with common off
Autosequence setting: Switch pump after 4 starts	4

**Table 4-2: Example Outputs**

Function	Configuration
Level measurement units	Feet
Relay 1 (Pump 1)	On: 5 ft. / Off: 1 ft.
Relay 2 (Pump 2)	On: 8 ft. / Off: 1 ft.
Relay 3 (High Alarm)	On: 12 ft. / Off: 11 ft.

### Procedure

1. From the Display's **Main menu** select **Setup wizard** → **Level and pump control**.

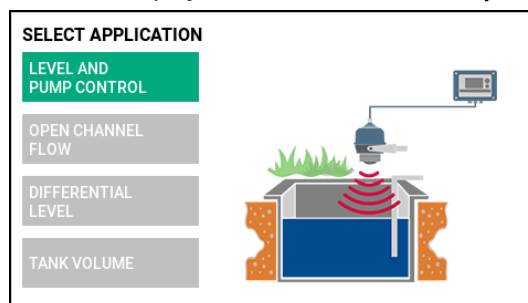



2. In the *Select input* window, select appropriate sensor input.

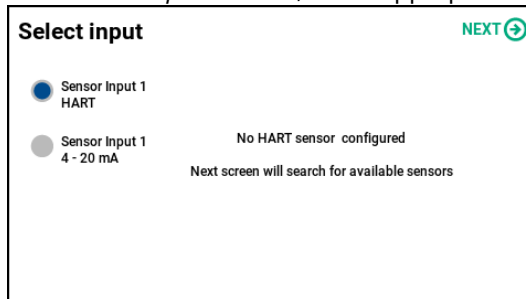

- a) Select **NEXT** , and press the enter key button to confirm your settings.

3. The *Search for HART sensor* window appears.

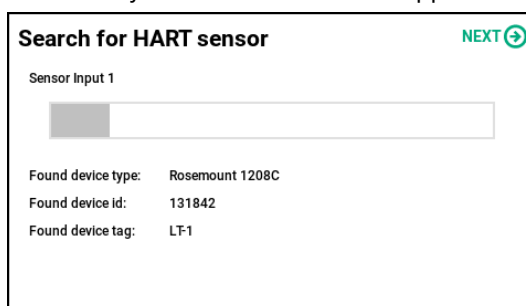

- a) Select **NEXT** , and press the enter key button to confirm your settings.

4. In the *Reference Height for Level Measurement* window, do the following:

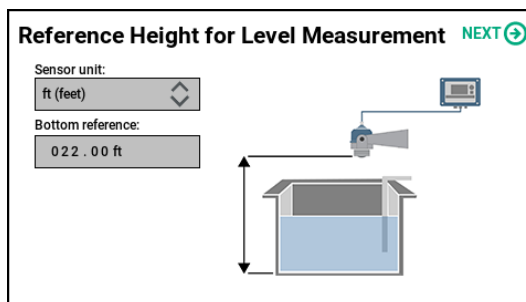

- a) In the *Sensor unit* list, select **ft (feet)**.
- b) In the *Bottom reference* box, enter 022.00 ft.
- c) Select **NEXT** , and press the enter key button to confirm your settings.

5. In the *Pump configuration* input window, do the following:

**Pump configuration** NEXT →

Pump mode: Assist com off

Number of pumps: 2

Auto sequence mode: Starts

Auto sequence value: 4

Pump 1 (relay 1) on: 005.00 ft

Pump 2 (relay 2) on: 008.00 ft

Pump common off: 001.00 ft

- a) In the *Pump mode* list, select **Assist com off**.
  - b) In the *Number of pumps* list, select **2**.
  - c) In the *Auto sequence mode* list, select **Starts**.
  - d) In the *Auto sequence value* list, select **4**.
  - e) In the *Pump 1 (relay 1) on* box, enter 005.00 ft.
  - f) In the *Pump 2 (relay 2) on* box, enter 008.00 ft.
  - g) In the *Pump common off* box, enter 001.00 ft.
  - h) Select **NEXT** →, and press the enter key button to confirm your settings.
6. In the *Relay configuration* input window, do the following:

**Relay configuration** NEXT →

Relay number: 3

Mode: High alarm

Alarm on when more than: 012.00 ft

Alarm off when less than: 011.00 ft

- a) In the *Relay number* list, select **3**.
- b) In the *Mode* list, select **High alarm**.
- c) In the *Alarm on when more than* box, enter 012.00 ft.
- d) In the *Alarm off when less than* box, enter 011.00 ft.
- e) Select **NEXT** →, and press the enter key button to confirm your settings.

7. In the *Analog output 1 configuration* input window, do the following:

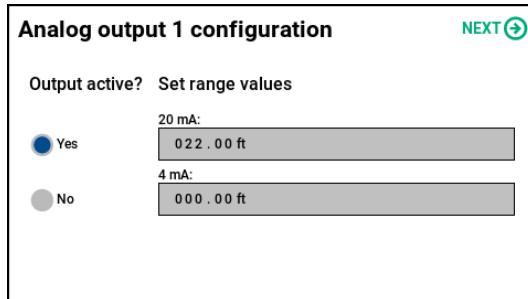

- a) Select the **Output active?** radio button **Yes**.
- b) In the *Set range values: 20 mA* box, enter 020.00 ft.
- c) In the *Set range values: 4 mA* box, enter 000.00 ft.
- d) Select **NEXT** with a right arrow icon, and press the enter key button to confirm your settings.

The *Summary* view is presented at the display:

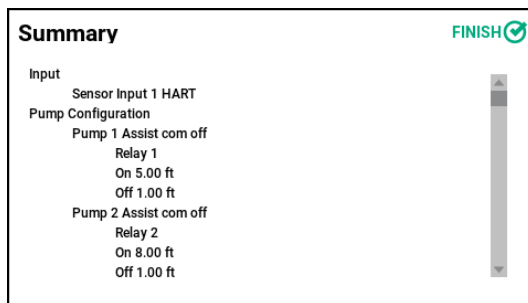

8. Select **FINISH** with a checkmark icon, and press the enter key button to return to the main screen:

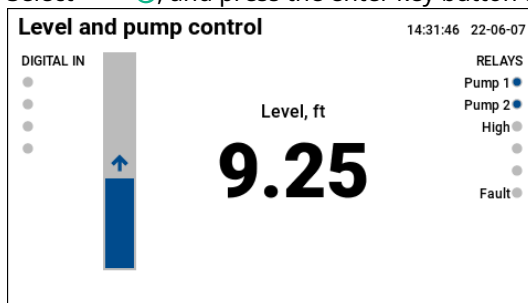

**Related information**

- [Pump modes](#)
- [Pump control](#)

## 4.4.2 Example: Set up an open channel flow application

**Table 4-3: Example Inputs**

Function	Configuration
Level measurement units	Feet
Open channel	60° V-Notch Weir
Maximum flow	645.50 gallons per minute
Height at maximum flow	1 ft.

**Table 4-4: Example Outputs**

Function	Configuration
Flow rate units	Gallons per minute
Totalized flow	Gallons x 100
Low flow cut-off	2 US gal/min

### Note

The data logging function is automatically activated for open channel flow applications (default logger interval: 15 minutes).

### Procedure

1. From the Display's **Main menu** select **Setup wizard** → **Open channel flow**.

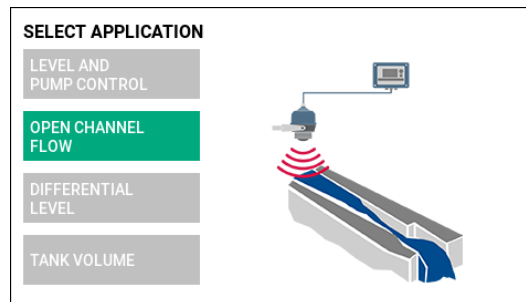

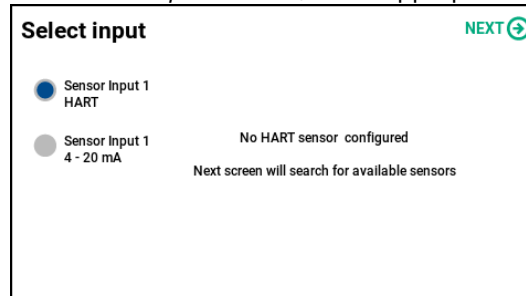

2. In the *Select input* window, select appropriate sensor input.

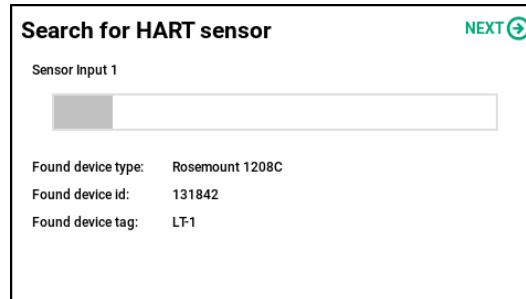

- a) Select **NEXT** , and press the enter key button to confirm your settings.

3. The *Search for HART sensor* window appears.



a) Select **NEXT** , and press the enter key button to confirm your settings.

4. In the *Reference Height for Flume / Weir* window, do the following:

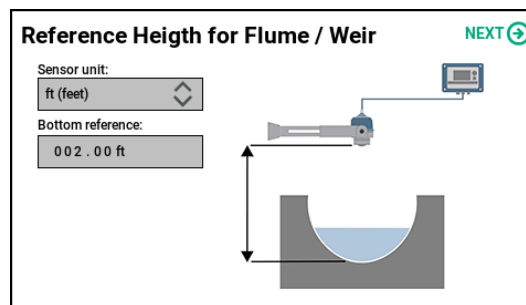

a) In the *Sensor unit* list, select **ft (feet)**.

b) In the *Bottom reference* box, enter 002.00 ft.

c) Select **NEXT** , and press the enter key button to confirm your settings.

5. In the *Select profile* input window, do the following:

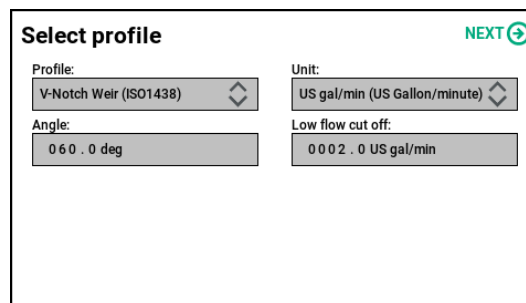

a) In the *Profile* list, select **V-Notch Weir (ISO1438)**.

b) In the *Angle* box, enter 060.0deg.

c) In the *Unit* list, select **US gal/min (US Gallon/minute)**.

d) In the *Low flow cut off* box, enter 0002.0US gal/min.

e) Select **NEXT** , and press the enter key button to confirm your settings.

6. In the *Totalizer configuration* input window, do the following:

**Totalizer configuration** NEXT →

Use totalizer?

Yes

No

Totalizer 1 Unit (Tot1) Accumulated  
US gal x 100

Totalizer 2 Unit (Tot2) Daily total  
US gal x 1

Totalizer 1 Relay

Totalizer 2 Relay

- a) Select the **Use totalizer?** radio button **Yes**.
- b) In the *Totalizer 1 Unit (Tot1) Accumulated* list, select **US gal x 100**.
- c) In the *Totalizer 2 Unit (Tot2) Daily total* list, select **US gal x 1**.
- d) Select **NEXT** →, and press the enter key button to confirm your settings.

7. In the *Relay configuration* input window, do the following:

**Relay configuration** NEXT →

Relay number: 1

Mode: Not in use

- a) In the *Relay number* list, select **1**.
- b) In the *Mode* list, select **Not in use**.
- c) Select **NEXT** →, and press the enter key button to confirm your settings.

8. In the *Analog output 1 configuration* input window, do the following:

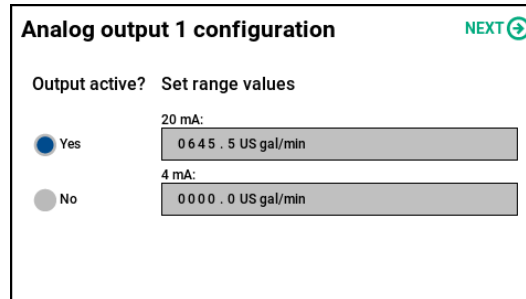

- Select the **Analog out?** radio button **Yes**.
- In the *Set range values: 20 mA* box, enter 0 6 4 5 . 5 US gal/min.
- In the *Set range values: 4 mA* box, enter 0 0 0 0 . 0 US gal/min.
- Select **NEXT** , and press the enter key button to confirm your settings.

The Summary is presented at the display:

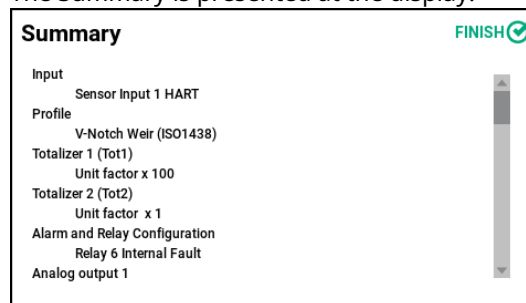

9. Select **FINISH** , and press the enter key button to return to the main screen:

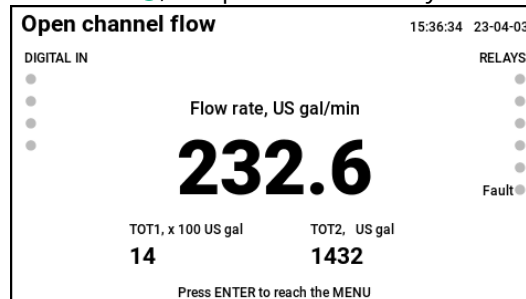

**Related information**

- [Setup logger](#)
- [Download log file to a PC](#)
- [Data logging](#)
- [Flow profiles](#)
- [Totalizer configuration](#)

### 4.4.3 Example: Set up a differential level application

**Table 4-5: Example Inputs**

Function	Configuration
Level measurement units	Meter
Transmitter 1 bottom reference	5 m
Transmitter 2 bottom reference	5 m
Calculation method	Difference

**Table 4-6: Example Outputs**

Function	Configuration
Level measurement units	Meter
Relay 1 (Out of limits alarm)	On: 0.5 m / Off: 0.1 m
Analog output 1	0 to 5 m
Analog output 2	0 to 5 m
Analog output 3	-5 to 5 m

#### Procedure

1. From the Display's **Main menu** select **Setup wizard** → **Differential level**.

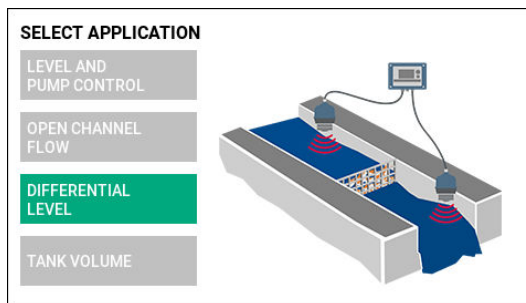

2. In the *Select input* window, select appropriate sensor input.

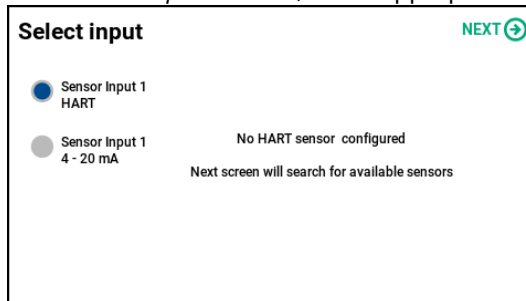

- a) Select **NEXT** →, and press the enter key button to confirm your settings.



3. The *Search for HART sensor* window appears.

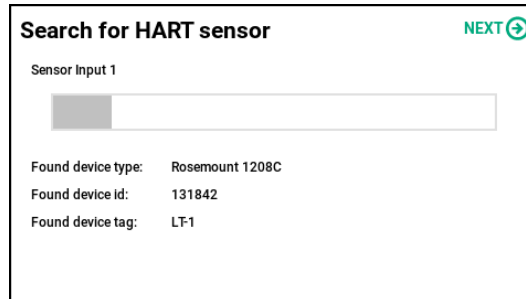

a) Select **NEXT** , and press the enter key button to confirm your settings.

4. In the *Reference Height for Sensor 1* window, do the following:

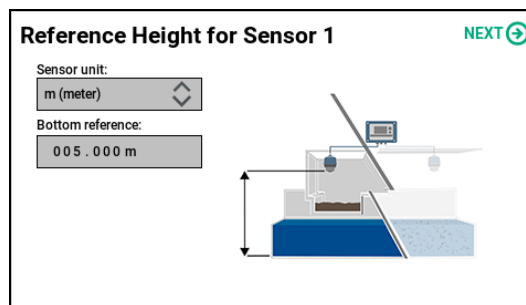

a) In the *Sensor unit* list, select **m (meter)**.

b) In the *Bottom reference* box, enter 005.00 m.

c) Select **NEXT** , and press the enter key button to confirm your settings.

5. In the *Reference Height for Sensor 2* window, do the following:

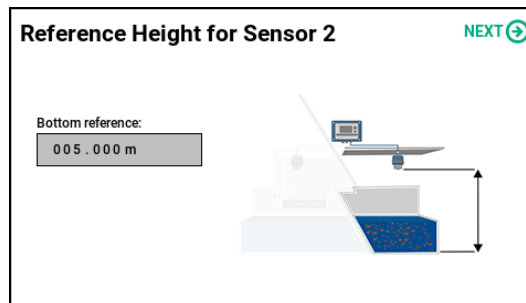

a) In the *Bottom reference* box, enter 005.00 m.

b) Select **NEXT** , and press the enter key button to confirm your settings.

6. In the *Relay configuration* window, do the following:

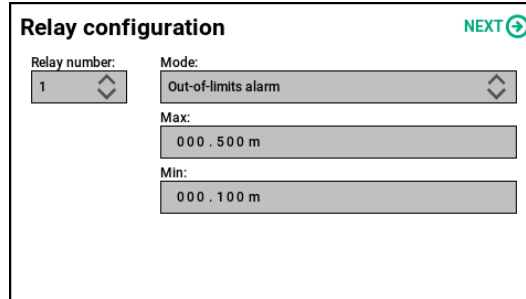

- In the *Relay number* list, select **1**.
  - In the *Mode* list, select **Out-of-limits alarm**.
  - In the *Max* box, enter 000 . 500 m.
  - In the *Min* box, enter 000 . 100 m.
  - Select **NEXT** , and press the enter key button to confirm your settings.
7. In the *Wizard/Analog output 1 configuration* input window, do the following:

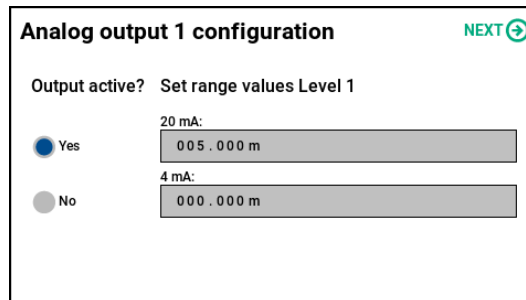

- Select the **Output active?** radio button **Yes**.
- In the *Set range values: 20 mA* box, enter 005 . 00 m.
- In the *Set range values: 4 mA* box, enter 000 . 00 m.
- Select **NEXT** , and press the enter key button to confirm your settings.

8. In the *Wizard/Analog output 2 configuration* input window, do the following:

- Select the **Output active?** radio button **Yes**.
- In the *Set range values: 20 mA* box, enter 005.00 m.
- In the *Set range values: 4 mA* box, enter 000.00m.
- Select **NEXT** , and press the enter key button to confirm your settings.

9. In the *Wizard/Analog output 3 configuration* input window, do the following:

- Select the **Output active?** radio button **Yes**.
- In the *Set range values: 20 mA* box, enter +005.00m.
- In the *Set range values: 4 mA* box, enter -000.00m.
- Select **NEXT** , and press the enter key button to confirm your settings.

The Summary is presented at the display:

10. Select **FINISH** , and press the enter key button to return to the main screen:

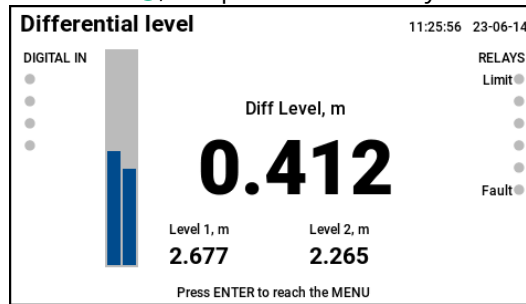

## 4.4.4 Example: Set up a tank volume application

**Table 4-7: Example Inputs**

Function	Configuration
Level measurement units	Feet
Transmitter bottom reference	7.5 ft
Tank type	Horizontal cylinder with flat ends
Tank dimensions	Diameter: 6.5 ft. / Length: 25 ft.
Volume capacity	6205.6 gallons

**Table 4-8: Example Outputs**

Function	Configuration
Contents volume units	US gallons
Relay on	6000 gallons
Relay off	5800 gallons
Current output range	0 to 6200 gallons

### Procedure

1. From the Display's **Main menu** select **Setup wizard** → **Level volume**.

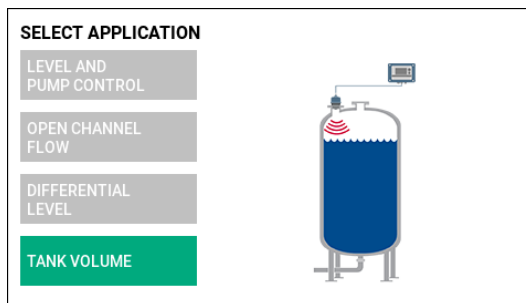

2. In the *Select input* window, select appropriate sensor input.

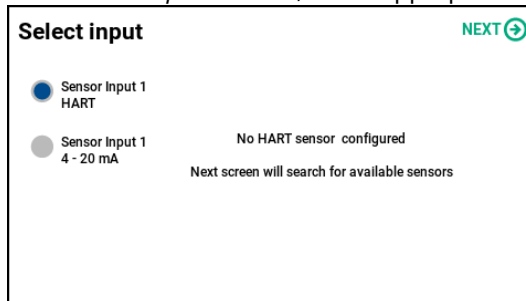

- a) Select **NEXT** →, and press the enter key button to confirm your settings.

3. The *Search for HART sensor* window appears.

- a) Select **NEXT** , and press the enter key button to confirm your settings.

4. In the *Reference Height for Tank Level* window, select appropriate sensor input.

- a) In the *Unit* list, select **ft (feet)**.  
 b) In the *20 mA* box, enter 007.50 ft.  
 c) Select **NEXT** , and press the enter key button to confirm your settings.

5. In the *Select profile* input window, do the following:

- a) In the *Profile* list, select **Horiz Cyl flat**.  
 b) In the *Method* list, select **Tank dimensions**.  
 c) In the *Diameter* box, enter 006.50 ft.  
 d) In the *Length* box, enter 025.00 ft.  
 e) In the *Unit* list, select **US gal (US Gallon)**.  
 f) In the *Height for max volume* box, enter 006.50 ft.  
 g) Select **NEXT** , and press the enter key button to confirm your settings.

6. In the *Wizard / Relay configuration* input window, do the following:

- a) In the *Relay number* list, select **1**.
- b) In the *Mode* list, select **High alarm**.
- c) In the *Alarm on when more than* box, enter 06000.0 US gal.
- d) In the *Alarm off when less than* box, enter 05800.0 US gal.
- e) Select **NEXT** with a right arrow, and press the enter key button to confirm your settings.

7. In the *Wizard/Analog output 1 configuration* input window, do the following:

- a) Select the **Output active?** radio button **Yes**.
- b) In the *Set range values: 20 mA* box, enter 06200.0 US gal.
- c) In the *Set range values: 4 mA* box, enter 00000.0 US gal.
- d) Select **NEXT** with a right arrow, and press the enter key button to confirm your settings.

The *Summary* view is presented at the display:

8. Select **FINISH** , and press the enter key button to return to the main screen:

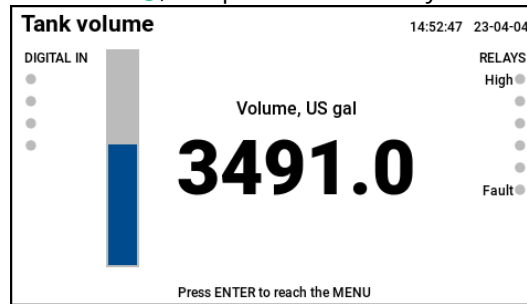

**Related information**

[Volume profiles](#)



## 4.5 Configure device settings

### 4.5.1 Set date and time

Use the Date/Time settings menu to select date format, and set current date and time.

#### Procedure

1. From the Display's **Main menu** select **Settings** → **Date/Time**.
2. In the *Settings/Set Date and Time* window, do the following:

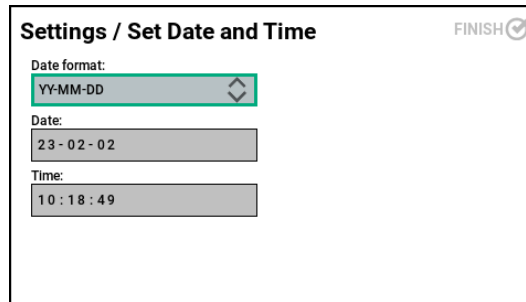

- a) In the *Date format* list, select desired format.
  - b) In the *Date* box, enter current date.
  - c) In the *Time* box, enter current time.
3. Select **FINISH** , and press the enter key button to confirm your settings.

### 4.5.2 Set up display

Use the Display settings menu to set the screen saver timeout and adjust the display brightness.

#### Procedure

1. From the Display's **Main menu** select **Settings** → **Display**.
2. In the *Settings/Display options* window, do the following:

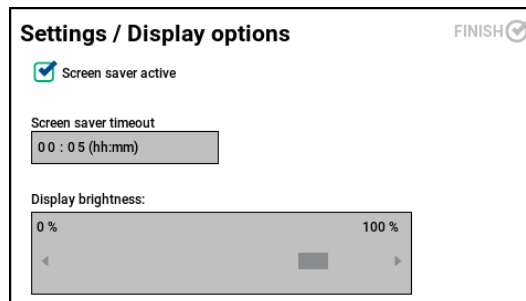

- a) Select the **Screen saver active** check box to enable the screen saver. In the *Screen saver timeout* box, enter desired time.
  - b) Use the left and right key buttons to move the **Display brightness** slider in order to adjust the display brightness.
3. Select **FINISH** , and press the enter key button to confirm your settings.

### 4.5.3 Set device IP address

Use the IP settings menu to enter the desired IP address settings. The controller IP address from factory is: 192.168.4.10.

#### Procedure

1. From the Display's **Main menu** select **Settings** → **Date/Time**.
2. In the *Settings/IP setting* window, do the following:

- a) In the *IP address* box, enter desired IP address.
  - b) In the *Subnet mask* box, enter desired subnet mask.
  - c) In the *Default gateway* box, enter desired default gateway.
3. Select **FINISH** , and press the enter key button to confirm your settings.

### 4.5.4 Set remote services access

#### Procedure

1. From the Display's **Main menu** select **Settings** → **Remote services**.
2. In *Settings/Remote Services* window, select/deselect check boxes to enable/disable desired remote services:

Modbus TCP/IP server	Description
Server enabled	Option to enable Modbus TCP/IP connectivity. Unselect to disable the connectivity in case no data access from host system is required.
Holding register write access	Option to allow connected Modbus TCP/IP client to change controller configuration using holding registers. Unselect to set the Modbus TCP/IP connectivity to read-only mode.

HTTP server	Description
Server enabled	Option to enable HTTP connectivity. Unselect to disable the connectivity in case web interface access is not required.
Firmware upgrade access	Option to allow controller firmware upgrade through the web interface. Unselect to disable this functionality in case firmware upgrade should not be accessible by web interface users.
Logfile download access	Option to allow controller download of log files through the web interface. Unselect to disable this functionality in case logfile download should not be accessible by web interface users.

3. Select **FINISH** , and press the enter key button to confirm your settings.

## 4.6 Configure digital inputs

For applications where the controller functionality is linked to other external events, there are up to four digital input ports for accepting contact closure signals.

The digital inputs can be individually setup to perform various control actions (e.g. raise an alarm) whenever activated. Use the Advanced configuration menu for all digital input configuration.

### 4.6.1 Configure digital input action

#### Procedure

1. From the Display's **Main menu**, select **Advanced configuration** → **Digital input**.
2. In the *Digital input* window, select desired digital input:

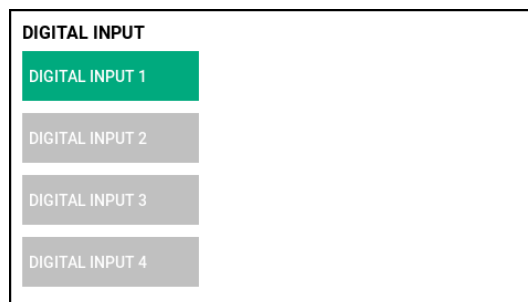

3. Select **Action**.

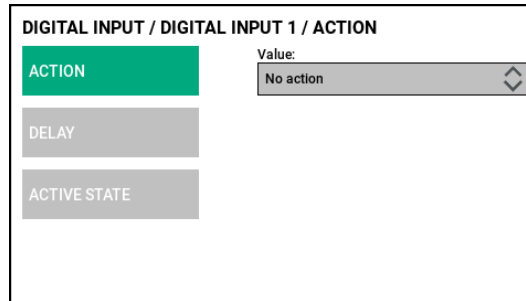

4. In the *Value* list, select desired digital input action, for example Hold Totalizer 1.

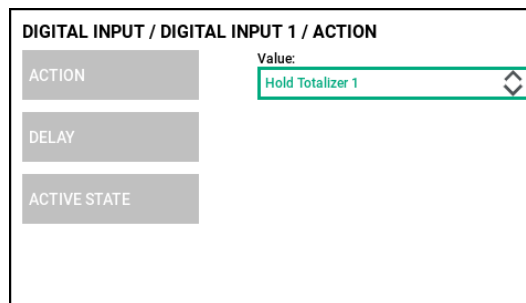

5. Press the back key button to return to the main screen.  
The selected digital input action is indicated at the main screen:

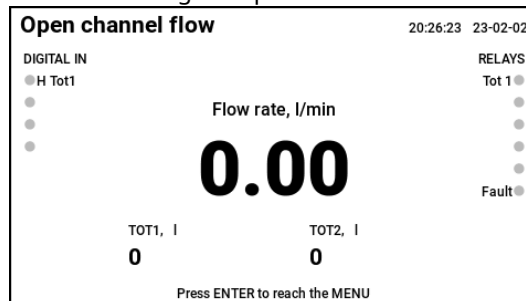

**Related information**

[Digital input actions](#)

## 4.6.2 Set digital input delay

**Procedure**

1. From the Display's *Main menu*, select **Advanced configuration** → **Digital input**.

2. In the *Digital input* window, select desired digital input:

DIGITAL INPUT

DIGITAL INPUT 1

DIGITAL INPUT 2

DIGITAL INPUT 3

DIGITAL INPUT 4

3. Select **Delay**.

DIGITAL INPUT / DIGITAL INPUT 1 / DELAY

ACTION

Value: 0

DELAY

ACTIVE STATE

4. In the *Value* list, specify digital input delay in seconds. Then press the enter key button to confirm your settings.

DIGITAL INPUT / DIGITAL INPUT 1 / DELAY

ACTION

Value: 5

DELAY

ACTIVE STATE

5. Press the back key button to return to the main screen.

#### Related information

[Delay](#)

### 4.6.3 Set digital input active state

To change the logic of a digital input:

#### Procedure

1. From the Display's *Main menu*, select **Advanced configuration** → **Digital input**.

- In the *Digital input* window, select desired digital input:

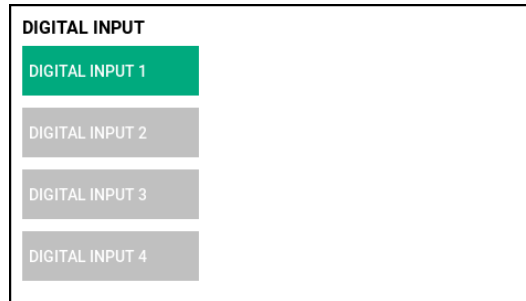

DIGITAL INPUT

DIGITAL INPUT 1

DIGITAL INPUT 2

DIGITAL INPUT 3

DIGITAL INPUT 4

- Select **Active state**.

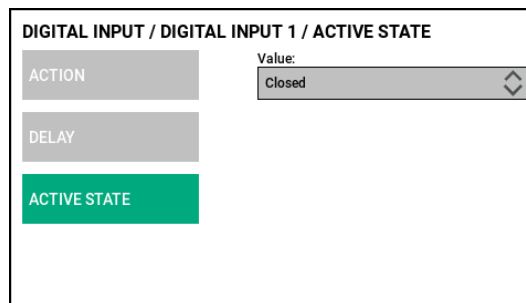

DIGITAL INPUT / DIGITAL INPUT 1 / ACTIVE STATE

ACTION

Value: Closed

DELAY

ACTIVE STATE

- In the *Value* list, select desired option:

Option	Description
Closed	Action is triggered when the voltage-free contact is closed.
Open	Action is triggered when the voltage-free contact is open.

- Press the enter key button to confirm your settings, and then press the back key button to return to the main screen.

### Related information

[Active state](#)

# 5 Operation

## 5.1 Safety messages

Instructions and procedures in this section may require special precautions to ensure the safety of the personnel performing the operations. Information that potentially raises safety issues is indicated by a warning symbol () . Refer to the following safety messages before performing an operation preceded by this symbol.

### **WARNING**

**Failure to follow safe installation and servicing guidelines could result in death or serious injury.**

Use the controller only as specified in this Reference Manual.

The controller must be installed, connected, commissioned, operated, and maintained by suitably qualified personnel only, observing national and local requirements that may apply.

The controller must be installed according to the Rosemount 3490 [Product Certifications](#) document.

Before commissioning the controller, ensure that the supply voltage matches the voltage specifications on the main label.

Repair, e.g. substitution of components, etc. may jeopardize safety and is under no circumstances allowed.

**Electrical shock could cause death or serious injury.**

Ensure that the controller is not powered when opening the lid and making terminal connections.

If the controller is installed in a high voltage environment and a fault condition or installation error occurs, high voltage may be present on leads and terminals.

### **CAUTION**

**Pollution protection**

Ensure that during installation or maintenance no moisture or dirt can get inside the instrument.

To maintain the housing protection, ensure that the housing lid is closed during operation and locked, if necessary.

## 5.2 Display

The controller display serves as an interface for the user to visualize measured values and status of inputs and outputs. Depending on the selected application, different calculated values will also be presented on the display.

**Figure 5-1: Typical Display Presentation**

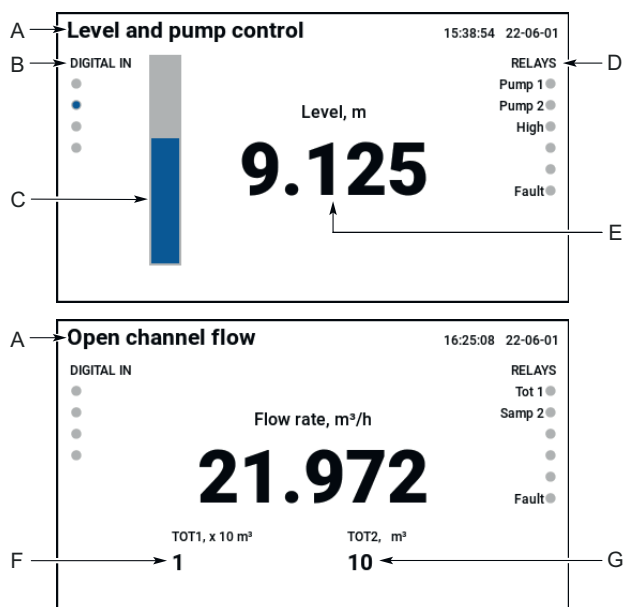

- A. Selected application
- B. Digital input status
- C. Bar graph of calculated value
- D. Relay status
- E. Calculated value
- F. Totalizer 1 value (accumulated)
- G. Totalizer 2 value (daily)

### 5.2.1 Variable screens

The controller can display the following variables:

**Table 5-1: LCD Display Variables**

Parameter	Presentation on (main) screen	Description
Level	Level	The current level measurement value.
Volume	Volume	The current volume measurement value.
Flow rate	Flow rate	The current velocity at which the volume is moving.
Totalizer 1	TOT1	The current accumulated totalizer value.
Totalizer 2	TOT2	The current daily totalizer value.



**Table 5-1: LCD Display Variables (continued)**

Parameter	Presentation on (main) screen	Description
Rate of Change	Level, Volume, or Flow Rate	The current rate of change of the Level, Volume, or Flow Rate value, depending on configured application.

**Related information**

- [Middle, left, and right field content](#)
- [Bargraph field content](#)

## 5.2.2 Status presentation on display

The overall controller status is presented on the display main screen. Diagnostic alerts are reported when there is a device malfunction. The different fault categories are displayed in [Table 5-2](#).







**Table 5-2: Presentation of Controller Status Images as per NAMUR NE 107**

Status image	Category	Description
	Failure	At least one Failure alert is active.
	Function Check	At least one Function Check alert is active (and no active Failure alert).
	Out of Specification	At least one Out of Specification alert is active (and no active Failure or Function Check alert).
	Maintenance Required	At least one Maintenance Required alert is active (and no active Failure, Function Check, or Out of Specification alert).

## 5.3 Keypad

The keypad function buttons are used to navigate through the software menu system, to configure and setup the controller.

**Table 5-3: Keypad Function Buttons**

Button	Action
	The enter button is used to access the menu system, select a menu option, or to confirm settings.
	The up arrow button is used to move upwards when navigating the menu system, or to scroll through a list of options. When editing a parameter value, the up arrow button is used to increase a digit.
	The down arrow button is used to move downwards when navigating the menu system, or to scroll through a list of options. When editing a parameter value, the down arrow button is used to decrease a digit.
	The left arrow button is used to move left when navigating the menu system. When editing a parameter value, the left arrow button is used to move left to another digit.
	The right arrow button is used to move right when navigating the menu system. When editing a parameter value, the right arrow button is used to move right to another digit.
	When navigating the menu system, the back button is used to return to a previous menu level or the main screen. At other times, e.g. while editing, the button is used to restore a setting that is being edited.

## 5.4 Light emitting diode

There is one Light Emitting Diode (LED) located on the front of the controller for status and error information.

### 5.4.1 LED status presentation

The overall controller status is indicated by the LED color code. Diagnostic alerts are reported when there is a device malfunction, the different fault categories are displayed in [Table 5-4](#).

**Table 5-4: LED Color Codes as per NAMUR NE 107**

LED color	Category	Description
Red	Failure	At least one Failure alert is active.
Orange	Function Check	At least one Function Check alert is active (and no active Failure alert).
Yellow	Out of Specification	At least one Out of Specification alert is active (and no active Failure or Function Check alert).
Blue	Maintenance Required	At least one Maintenance Required alert is active (and no active Failure, Function Check, or Out of Specification alert).

## 5.4.2 LED start-up information

When the controller is starting up, the LED indicates possible hardware or software errors as shown in [Table 5-5](#).

**Table 5-5: LED Error Indication at Start-Up**

Color	Blink interval	Description
Green	0.5 seconds	Normal boot in progress
Green	2 seconds	Firmware upgrade in progress
Yellow	2 seconds	Recovery phase in progress
Red	0.5 seconds	Critical failure, unknown reason
Red	1second	Critical failure, no good firmware found or broken flash
Red	2 seconds	Critical failure, bad RAM or SDRAM

## 5.5 Read data from Modbus® register

The Rosemount 3490 Controller stores measurement data, calculated values, and status information in Modbus input registers. The controller Ethernet port can be used for Modbus TCP/IP connection to host systems. By connecting the controller to an existing LAN network, the input registers can be scanned in queries from a Modbus master, such as a local PC or host system.

### Related information

[Modbus register table](#)

## 5.6 Security

### 5.6.1 Write protection

By default, security restrictions are switched off and the user has access to all configuration settings. The controller can be write protected to prevent unauthorized changes to the configuration. A digital input can be configured to activate write protection. The controller is write protected while the digital input is active.

### Related information

[Digital input actions](#)

[Configure digital input action](#)

### 5.6.2 Access protection

By default, security restrictions are switched off and the user has access to all configuration settings. After configuration is complete, a pin security code can be setup to prevent unauthorized access.

Pin code can be setup to protect the device from any unwanted changes from the local display and/or webserver.

## Set pin code for device access

### Procedure

1. From the Display's **Main menu** select **Settings** → **IP settings**.
2. In the *Settings/Security* window, do the following:

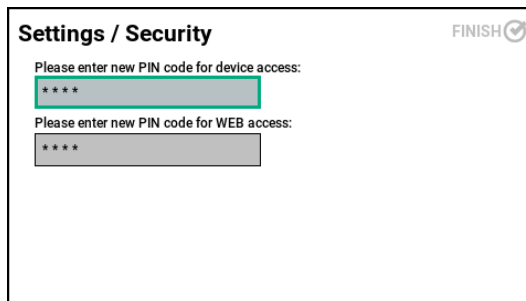

The screenshot shows a window titled "Settings / Security" with a "FINISH" button and a checkmark icon in the top right corner. Below the title, there are two input fields. The first field is labeled "Please enter new PIN code for device access:" and contains four asterisks. This field is highlighted with a green border. The second field is labeled "Please enter new PIN code for WEB access:" and also contains four asterisks.

- a) In the **Please enter new PIN code for device access** box, enter desired four-digit device pin code.
3. Select **FINISH** , and press the enter key button to confirm your settings.

## Set pin code for web access

Use the PIN security settings to set the pin code for access to the controller's web interface. The pin code from factory is: 0000.

### Procedure

1. From the Display's **Main menu** select **Settings** → **IP setting**.
2. In the *Settings/Security* window, do the following:

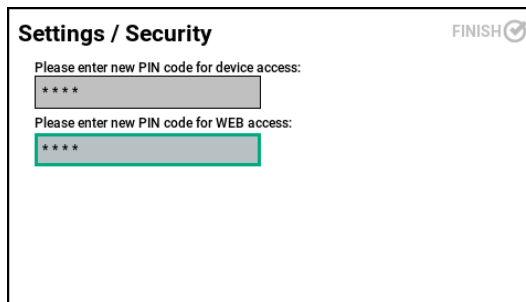

The screenshot shows a window titled "Settings / Security" with a "FINISH" button and a checkmark icon in the top right corner. Below the title, there are two input fields. The first field is labeled "Please enter new PIN code for device access:" and contains four asterisks. The second field is labeled "Please enter new PIN code for WEB access:" and contains four asterisks. This second field is highlighted with a green border.

- a) In the **Please enter new PIN code for WEB access** box, enter desired web pin code.
3. Select **FINISH** , and press the enter key button to confirm your settings.

### 5.6.3 Securing lid

To prevent unauthorized access, the controller lid can be secured by using the sealing arc.

**Figure 5-2: Sealing arc to secure the lid**

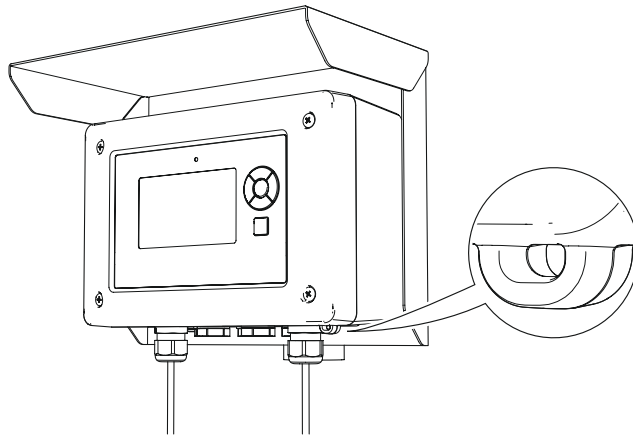



## 6 Service and troubleshooting

### 6.1 Safety messages

Instructions and procedures in this section may require special precautions to ensure the safety of the personnel performing the operations. Information that potentially raises safety issues is indicated by a warning symbol (⚠). Refer to the following safety messages before performing an operation preceded by this symbol.

#### **⚠ WARNING**

**Failure to follow safe installation and servicing guidelines could result in death or serious injury.**

Use the controller only as specified in this Reference Manual.

The controller must be installed, connected, commissioned, operated, and maintained by suitably qualified personnel only, observing national and local requirements that may apply.

The controller must be installed according to the Rosemount 3490 [Product Certifications](#) document.

Before commissioning the controller, ensure that the supply voltage matches the voltage specifications on the main label.

Repair, e.g. substitution of components, etc. may jeopardize safety and is under no circumstances allowed.

**Electrical shock could cause death or serious injury.**

Ensure that the controller is not powered when opening the lid and making terminal connections.

If the controller is installed in a high voltage environment and a fault condition or installation error occurs, high voltage may be present on leads and terminals.

#### **⚠ CAUTION**

**Pollution protection**

Ensure that during installation or maintenance no moisture or dirt can get inside the instrument.

To maintain the housing protection, ensure that the housing lid is closed during operation and locked, if necessary.

### 6.2 Diagnostic messages per NAMUR NE 107

Diagnostic alerts are reported when there is a device malfunction. The alert messages are presented on the display main screen with recommended actions.

The diagnostic messages in this section are organized according to the four NAMUR NE 107 alert categories.

**Related information**

[Status presentation on display](#)

LED status presentation

## 6.2.1 Failure alarms

**Table 6-1: Failure Alarms for Rosemount 3490**

Failure alarm	Description
Sensor Input 1 open loop	Open loop detected for Sensor Input 1 connection. The control loop output is invalid.
Sensor Input 1 failure low	The transmitter connected to Sensor Input 1 indicates failure low current. The control loop output is invalid.
Sensor Input 1 failure high	The transmitter connected to Sensor Input 1 indicates failure high current. The control loop output is invalid.
Sensor Input 1 short circuit	Short-circuit detected for Sensor Input 1 connection. The control loop output is invalid.
Sensor Input 2 open loop	Open loop detected for Sensor Input 2 connection. The control loop output is invalid.
Sensor Input 2 failure low	The transmitter connected to Sensor Input 2 indicates failure low current. The control loop output is invalid.
Sensor Input 2 failure high	The transmitter connected to Sensor Input 2 indicates failure high current. The control loop output is invalid.
Sensor Input 2 short circuit	Short-circuit detected for Sensor Input 2 connection. The control loop output is invalid.
HART Device 1 not responding	The HART transmitter connected to Sensor Input 1 is not responding. The control loop output is invalid.
HART Device 1 invalid measurement value	The HART transmitter connected to Sensor Input 1 reports invalid measurement value. The control loop output is invalid.
HART Device 2 not responding	The HART transmitter connected to Sensor Input 2 is not responding. The control loop output is invalid.
HART Device 2 invalid measurement value	The HART transmitter connected to Sensor Input 2 reports invalid measurement value. The control loop output is invalid.
Digital Input IN 1 fault indication	Digital Input IN 1 indicates fault condition. The control loop output is invalid.
Digital Input IN 2 fault indication	Digital Input IN 2 indicates fault condition. The control loop output is invalid.
Digital Input IN 3 fault indication	Digital Input IN 3 indicates fault condition. The control loop output is invalid.
Digital Input IN 4 fault indication	Digital Input IN 4 indicates fault condition. The control loop output is invalid.
Configuration error	The controller has detected a configuration error. The control loop output is invalid.
Electronics Failure, MCU Board	An electronic error has occurred. The control loop output is invalid.
Electronics Failure, I/O Board	An electronic error has occurred. The control loop output is invalid.
Field calibration fault	Analog field calibration failed. The control loop output is invalid.
Electronics Failure, HART 1 Modem	An electronics error has occurred. The control loop output is invalid.
Electronics Failure, HART 2 Modem	An electronics error has occurred. The control loop output is invalid.
Device Memory Failure	A device memory error has occurred. The control loop output is invalid.
Startup Failure	Controller repeatedly failed to start up with current configuration settings. The control loop output is invalid.



**Table 6-1: Failure Alarms for Rosemount 3490 (continued)**

Failure alarm	Description
Software Error	The software in the controller encountered a problem and stopped running which may cause invalid control loop output.

## 6.2.2 Function check alarms

**Table 6-2: Function check Alarms for Rosemount 3490**

Function check alarm	Description
Analog Output 1 out of range	The configured span for analog output 1 is too small.
Analog Output 2 out of range	The configured span for analog output 2 is too small.
Analog Output 3 out of range	The configured span for analog output 3 is too small.
Control loop not configured	Incomplete or missing control loop configuration. The controller is unable to perform its primary function.
Control loop not running	Controller is in configuration mode and is not reporting actual information.
Simulation mode active	The controller is in simulation mode and is not reporting actual information.
Alarm suppression enabled	Alarm suppression is enabled and the controller is thus not reporting alarms-on-screen, nor on analog outputs or relay outputs.

## 6.2.3 Maintenance required alarms

**Table 6-3: Maintenance Required Alarms for Rosemount 3490**

Maintenance required alarm	Description
Relay inactive for too long	The configured relay has exceeded its user defined limit for time being inactive.
Relays number of operations exceeded	The configured Relay has exceeded its user defined limit of number of operations.
Relay runtime exceeded	The configured relay has exceeded its user defined limit for time being energized.
Rising level alarm	Level is unexpectedly rising while pumps are running.
Keypad key is stuck	One or more keys are stuck in pressed state.
Logging memory almost full	Unused logging memory is below the user defined limit. When logging memory is full, logged data is overwritten or logging is stoppet depending on configuration.
Logging memory is full	Logging memory is full. When logging memory is full, logged data is overwritten or logging is stopped depending on configuration.
Pump efficiency alarm	Pump have loss efficiency.

## 6.2.4 Out of specification alarms

**Table 6-4: Out of Specification Alarms for Rosemount 3490**

Out of specification alarm	Description
Sensor Input 1 saturation low	The transmitter connected to Sensor Input 1 indicates saturation low current. The control loop may be affected.
Sensor Input 1 saturation high	The transmitter connected to Sensor Input 1 indicates saturation high current. The control loop may be affected.
Sensor Input 2 saturation low	The transmitter connected to Sensor Input 2 indicates saturation low current. The control loop may be affected.
Sensor Input 2 saturation high	The transmitter connected to Sensor Input 2 indicates saturation high current. The control loop may be affected.
HART Device 1 outside sensor limits	The HART transmitter connected to Sensor Input 1 reports measurement outside sensor limits. The control loop may be affected.
HART Device 2 outside sensor limits	The HART transmitter connected to Sensor Input 2 reports measurement outside sensor limits. The control loop may be affected.
Linearized Variable out-of-range	The level measurement is outside the configured range for volume or flow. Accuracy of volume/flow calculation may be degraded.
Electronics temperature out-of-range	The temperature of the electronics board has exceeded the operating range.
HART Device 1 outside output range	The HART transmitter connected to Sensor Input 1 reports measurement outside sensor limits. The control loop output may be affected.
HART Device 2 outside output range	The HART transmitter connected to Sensor Input 2 reports measurement outside sensor limits. The control loop output may be affected.

## 6.3 Alarm indication selection

The controller can detect the alarm conditions listed in [Alarm conditions configuration](#). These alarms may be externally signaled using the fault relay output and/or analog current outputs. The method of indication can be selected for each alarm condition.

### 6.3.1 Configure alarms for analog output

To select alarms to be externally signaled by analog output:

#### Procedure

1. From the Display's **Main menu**, select **Advanced configuration** → **Analog output**.
2. In the **Analog output** window, select desired analog output:

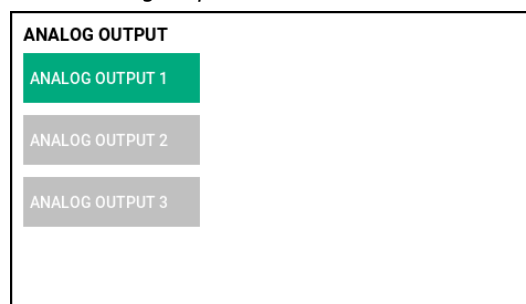

3. In the *Alarm config* window, do the following:

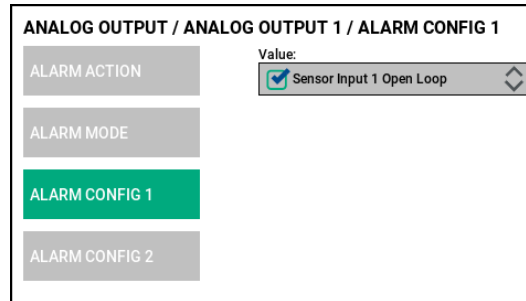

- a) Select **Alarm config 1** or **Alarm config 2**.  
Refer to [Alarm conditions configuration](#) for available alarm conditions and factory settings.
- b) In the *Value* list, select the check box to enable desired alarms.
- c) Press the enter key button to confirm your settings.
- d) Press the back key button to return to the main screen.

## 6.3.2 Configure alarms for fault relay

To select alarms to be externally signaled by the fault relay:

### Procedure

1. From the Display's *Main menu*, select **Advanced configuration** → **Relay output**.
2. In the *Relay output* window, select **Fault relay**.

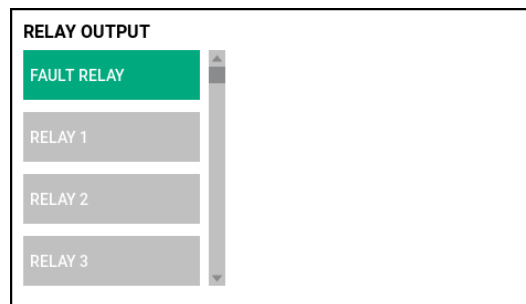

3. In the *Alarm config* window, do the following:

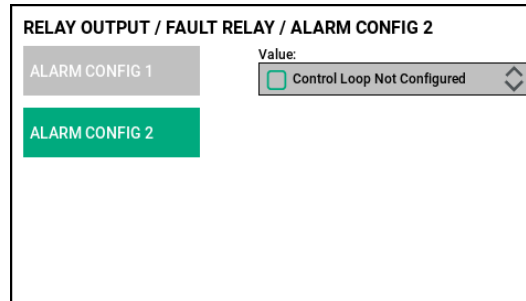

- a) Select **Alarm config 1** or **Alarm config 2**.  
Refer to [Alarm conditions configuration](#) for available alarm conditions and factory settings.
- b) In the *Value* list, select the check box to enable desired alarms.
- c) Press the enter key button to confirm your settings.
- d) Press the back key button to return to the main screen.

## 6.4 Display service menu

### 6.4.1 View the about information

The About view presents controller information such as; part number, serial number, software version, Ethernet IP address, and licences.

#### Procedure

1. From the Display's **Main menu**, select **Service** → **About**.  
The About view appears, displaying specific device information:

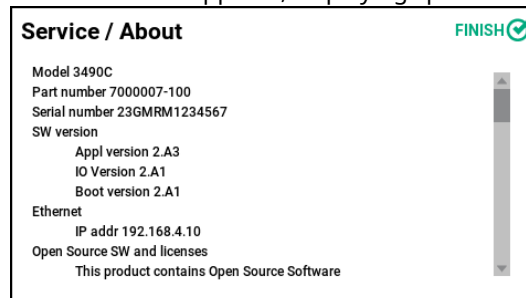

2. Select **FINISH** , and press the enter key button to return to the main screen.

## 6.4.2 Check status

The Status view presents controller status information such as; relay status, sensor input status, analog output status, logger, device operation time, temperature, and CPU load.

### Procedure

1. From the Display's **Main menu**, select **Service** → **Status**.  
The Status view appears, showing the current controller status:

Service / Status			FINISH
<b>Relay status</b>			
Relay	Run time	Operation counter	
Relay 1	0:00 (H:mm)	0	
Relay 2	0:00 (H:mm)	0	
Relay 3	0:00 (H:mm)	0	
Relay 4	0:00 (H:mm)	0	
Relay 5	0:00 (H:mm)	0	
Relay 6	0:00 (H:mm)	1	
<b>Sensor input 4-20mA status</b>			
Sensor	Value	Status	
1	0.0000 mA	Short low open loop	

2. Select **FINISH**, and press the enter key button to return to the main screen.

## 6.4.3 Reset totalizer

To reset the totalizer value to zero:

### Procedure

1. From the Display's **Main menu**, select **Service** → **Reset**.
2. Select the desired totalizer:

Option	Description
Reset totalizer 1	Reset totalizer 1 (accumulated)
Reset totalizer 2	Reset totalizer 2 (daily)

3. Select **OK** to confirm totalizer reset.

## 6.4.4 Reset alarm

To clear alarms and alerts that are no longer applicable due to changes in configuration:

### Procedure

1. From the Display's **Main menu**, select **Service** → **Reset**.
2. In the *Service/Reset* window select **Reset alarm**.
3. Select **OK** to confirm alarm reset.

## 6.4.5 Clear logger memory

To erase all logger memory entries:

### Prerequisites

All data will be lost. Consider downloading the log file prior to clearing logger memory.

#### Procedure

1. From the Display's **Main menu**, select **Service** → **Reset**.
2. In the *Service/Reset* window select **Clear logger memory**.
3. Select **OK** to confirm all logger entries to be erased.

#### Related information

[Download log file to a PC](#)

## 6.4.6 Reset field calibration

To reset field calibration to factory settings:

#### Procedure

1. From the Display's **Main menu**, select **Service** → **Reset**.
2. In the *Service/Reset* window select **Reset field calibration**.
3. Select **OK** to confirm field calibration to be reset to factory settings.

#### Related information

[Perform field calibration of sensor input 4-20 mA](#)

[Perform field calibration of analog output](#)

## 6.4.7 Restore to factory settings

This function restores the controller to factory settings (user configuration is overwritten).

#### Prerequisites

#### Note

Restoring the controller to factory default settings can not be reversed.

#### Procedure

1. From the Display's **Main menu**, select **Service** → **Reset**.
2. In the *Service/Reset* window select **Factory Reset**.

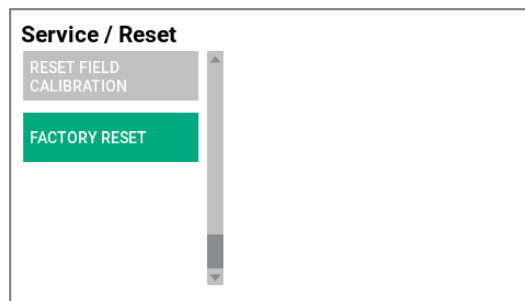

3. Select **OK** to confirm the factory reset.

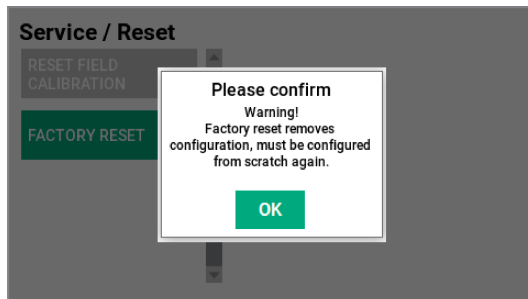

The controller is now restored to factory settings.

## 6.4.8 Turn off the control loop

Prior to performing field calibration or output signal simulation, the control loop must be turned off. When the control loop is turned off, processing of input signals is disabled, outputs are frozen, and totalizers are disabled.

### Procedure

1. From the Display's **Main menu**, select **Service** → **Control loop**.
2. In the *Service/Control loop* window, uncheck the **Control loop on** check box.

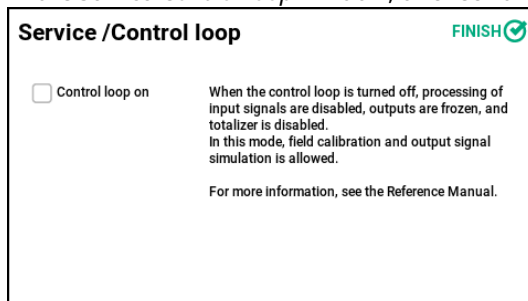

3. Select **FINISH** , and press the enter key button to confirm your settings.
4. Select **OK** to confirm control loop disabling.

## 6.4.9 Turn on the control loop

Turn on the control loop in order for the controller to resume normal operation.

### Procedure

1. From the Display's **Main menu**, select **Service** → **Control loop**.
2. In the *Service/Control loop* window, select the **Control loop on** check box.

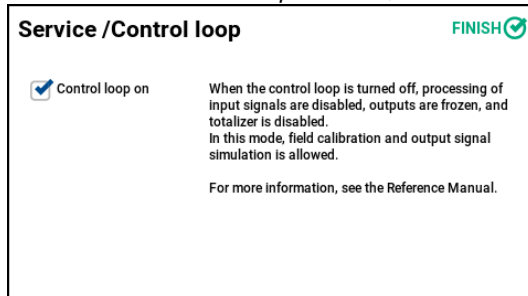

3. Select **FINISH** , and press the enter key button to confirm your settings.

## 6.4.10 Perform field calibration of sensor input 4-20 mA

To perform field calibration of sensor input 4-20 mA:



### Prerequisites

The control loop must be turned off prior to field calibration.

### Procedure

1. From the Display's **Main menu**, select **Service** → **Field calibration**.
2. In the *Calibration* window select **Sensor input 4-20 mA**.
3. In the *Sensor input 4-20 mA calibration* window select desired sensor input:

Option	Description
Input 1	Sensor input 1
Input 2	Sensor input 2 (only 3490C)

4. Ensure the calibration equipment is connected to the unit.
5. Apply 4 mA to the Sensor input terminal.
6. Select the **4 mA Applied** button.  
The Measured Sensor Input Current (mA) value is displayed.
7. Select **NEXT** , and press the enter key button.
8. Apply 20 mA to the Sensor input terminal.
9. Select the **20 mA Applied** button.  
The Measured Sensor Input Current (mA) value is displayed.
10. Select **NEXT** , and press the enter key button.
11. Verify that the expected measurement result appears in the *Measured Sensor Input Current (mA)* field.
12. Select **FINISH** , and press the enter key button.

### Postrequisites

Turn on the control loop to resume normal operation.

### Related information

[Reset field calibration](#)

[Turn off the control loop](#)

[Turn on the control loop](#)

## 6.4.11 Perform field calibration of analog output

To perform field calibration of analog input:

### Prerequisites

The control loop must be turned off prior to field calibration.



### Procedure

1. From the Display's **Main menu**, select **Service** → **Field calibration**.
2. In the *Calibration* window select **Analog output**.



- In the *Analog output calibration* window select desired analog output.

Option	Description
Output 1	Analog output 1
Output 2	Analog output 2 (only 3490C)
Output 3	Analog output 3 (only 3490C)

- Ensure the measuring equipment is connected to the Analog output terminals.
- Select the **Output 4 mA** button to apply 4 mA to the analog output.
- Enter the read analog output value in the **Analog Output Current (mA)** field, and press the enter key button.
- Select **NEXT** , and press the enter key button.
- Select the **Output 20 mA** button to apply 20 mA to the analog output.
- Enter the read analog output value in the **Analog Output Current (mA)** field, and press the enter key button.
- Select **NEXT** , and press the enter key button.  
The analog output calibration is completed.
- To validate the calibration, select the **Output 4 mA** button and verify the value in measuring unit.
- To validate the calibration, select the **Output 20 mA** button and verify the value in measuring unit.
- Select **FINISH** , and press the enter key button.

#### Postrequisites

Turn on the control loop to resume normal operation.

#### Related information

[Reset field calibration](#)

[Turn off the control loop](#)

[Turn on the control loop](#)

## 6.4.12 Use the input simulation mode

To use the input simulation mode:

#### Procedure

- From the Display's **Main menu**, select **Service** → **Simulation**.
- In the *Simulation menu* window select **Input simulation**.

3. In the *Simulation/Input Control* window, do the following:

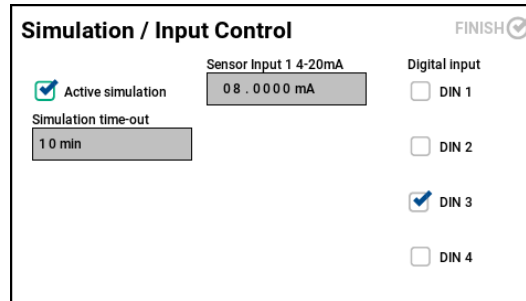

- Select the **Active simulation** check box to activate the input simulation mode.
- In the *Simulation time-out* box enter desired simulation duration, maximum 59 minutes.
- Enter desired input simulation settings, for example *Sensor Input 4-20 mA* and *Digital Input*.
- Select **FINISH** , and press the enter key button to activate simulation mode.

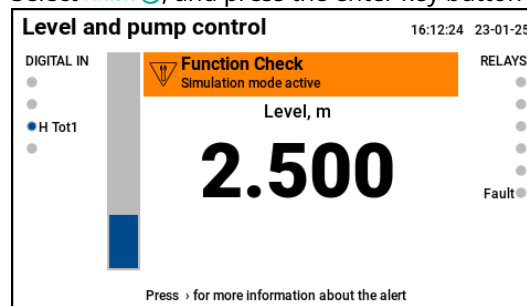

**Tip**

To quickly return to the *Simulation/Input Control* window, press the left key button.

**Note**

Simulation continues for the specified period of time. It can also be stopped manually at any time by unchecking the **Active simulation** check box.

## 6.4.13 Use the output simulation mode

To use the output simulation mode:

**Prerequisites**

The control loop must be turned off prior to using the output simulation mode.

**Procedure**

- From the Display's *Main menu*, select **Service** → **Simulation**.
- In the *Simulation menu* window select **Output simulation**.

3. In the *Simulation/Output Control* window, enter desired values and settings for output simulation.

**Simulation / Output Control** FINISH ✓

Analog output 1: 04.0000 mA

Analog output 2: 08.0000 mA

Analog output 3: 20.0000 mA

Relay output:

1: Not in use    4: Not in use

2: Not in use    5: Not in use

3: Not in use    6: Fault

**Note**

Output simulation is only active in the *Simulation/Output Control* window.

4. Select **FINISH** ✓, and press the enter key button to end the output simulation and return to the main screen.

**Postrequisites**

Turn on the control loop to resume normal operation.

**Related information**

[Turn off the control loop](#)

[Turn on the control loop](#)

## 6.4.14 Setup logger

**Procedure**

1. From the Display's *Main menu*, select **Service** → **Logger**. The *Setup/Logger* window appears:

**Setup / Logger** FINISH ✓

Logger interval: 1 min

Bad data trigger: DIN 1

Logging mode: Continuous

Alarm level (free space): 002.0%

Alarm relay: Yes

2. In the *Logger interval* list, select desired logger interval; 1-60 minutes (default: off).

3. In the *Bad data trigger* list, select desired option:

Option	Description
None	Bad data trigger not in use (default setting).
DIN 1	Set digital input 1 action to Bad data trigger.
DIN 2	Set digital input 2 action to Bad data trigger.
DIN 3	Set digital input 3 action to Bad data trigger (only 3490C).
DIN 4	Set digital input 4 action to Bad data trigger (only 3490C).

4. In the *Logging mode* list, select desired option:

Option	Description
Continuous	Continue data logging and overwrite the oldest data after the logging memory is full.
Stop when full	Stop data logging after the logging memory is full.

5. In the *Alarm level (free space)* box, enter limit value for unused logging memory.  
6. In the *Alarm relay* list, select desired option:

Option	Description
Yes	Set alarm option Logger memory almost full, to be indicated by a relay output.
No	Do not use relay output for alarm option Logger memory almost full.

7. Select **FINISH** , and press the enter key button to confirm your settings.

#### Related information

[Data logging](#)

## 6.5 Web interface

The Rosemount 3490 has a web-based graphical user interface that provides the following functions:

- Firmware upgrade
- Managing log files

### 6.5.1 Access the web interface

To access the controller's web interface:

#### Procedure

1. Connect a laptop to the controller's Ethernet port.

2. Set your laptop Ethernet port to a static IP address on the same subnet as the controller.
3. Enter the controller's IP address into your web browser.  
IP address from factory: 192.168.4.10
4. Enter the requested pin code.  
Pin code from factory: 0000



5. Once you are logged in, the web interface appears with a number of service menus.



#### Related information

[Set pin code for web access](#)

## 6.5.2 Upgrade firmware

### Prerequisites

#### Note

The firmware upgrade process must not be interrupted. When upgrading, do not unplug power supply or close the web browser until the process is complete. In case the upgrade process was interrupted, repeat the procedure.

### Procedure

1. Open the Web interface for the Rosemount 3490.
2. Select **Firmware upgrade** → **Select file**.
3. Browse to the firmware file and select **Open**.

After pressing the **Open** button a progress bar will be visible to indicate remaining time. When the upgrade is done, the system will switch to the log on window.

---

### Note

Upgrading the firmware may take several minutes. The system may seem unresponsive during the upgrade but will eventually reboot and come back online. Use the refresh function in the web browser to check if the web interface is back online.

---

4. Verify that the presented firmware version is updated by opening the **About** tab once the firmware upgrade is completed.

### Related information

[Access the web interface](#)

## 6.5.3 Download log file to a PC

### Procedure

1. Open the Web interface for the Rosemount 3490.
2. Select **Log data** → **Save log**.
3. In the *Log type* list, select desired log data type:

Option	Description
Parameter	Parameters configured to be shown on the main screen (main, left and right values and units), typically flow.
Totalizer	Values for accumulated totalizer (Tot1) and daily totalizer (Tot 2).

4. Select **Download**.  
Depending on the particular web browser that is used, the log file will be downloaded to the default folder for file download on the PC, or you may choose the desired destination folder.
5. Once the log file is downloaded, the file can be moved to the preferred location.

### Related information

[Access the web interface](#)

## Log files

Log files are stored in plain text file format (.csv) and can be viewed in any word processing program, customized for Microsoft® Excel® import.

Figure 6-1: Totalizer Log File Example

	A	B	C	D	E	F
1	Timestamp	Parameter	Value	Unit		
2	22-05-17 15:15	Totalizer1	101	m3		
3	22-05-17 15:30	Totalizer1	103	m3		
4	22-05-17 15:45	Totalizer1	105	m3		
5	22-05-17 16:00	Totalizer1	107	m3		
6	22-05-17 16:15	Totalizer1	109	m3		
7	22-05-17 16:30	Totalizer1	112	m3		
8	22-05-17 16:45	Totalizer1	114	m3		
9	22-05-17 17:00	Totalizer1	116	m3		

### 6.5.4

## Clear log file

To clear the log file:

### Prerequisites

All data will be lost. Consider downloading the log file prior to clearing the log file.

### Procedure

1. Open the Web interface for the Rosemount 3490.
2. Select **Log data** → **Clear log**.
3. Select **Ok** to confirm removal of all parameter data from the log.  
When finished, a message appears that the parameter data was successfully cleared.
4. Select **Ok** to return to the *Log Data* view.

### Related information

[Access the web interface](#)

[Download log file to a PC](#)

## 6.6

## Service support

To expedite the return process, refer to [Emerson.com](https://www.emerson.com) and contact the nearest Emerson representative.

### ⚠ CAUTION

Individuals who handle products exposed to a hazardous substance can avoid injury if they are informed of and understand the hazard. Returned products must include a copy of the required Safety Data Sheet (SDS) for each substance.

Emerson representatives will explain the additional information and procedures necessary to return goods exposed to hazardous substances.



# A Specifications and reference data

## A.1 General specifications

### A.1.1 Models

- Rosemount 3490A Controller
- Rosemount 3490C Controller

**Table A-1: Supported Applications**

Application	Rosemount 3490A	Rosemount 3490C
Level and pump control	✓	✓
Open channel flow	✓	✓
Differential level	-	✓
Tank volume	✓	✓

**Table A-2: Number of Ports**

Terminal	Number of ports	
	Rosemount 3490A	Rosemount 3490C
Sensor input	1	2
Digital input	2	4
Analog output	1	3
Relay output	3	6
Ethernet	1	1

### A.1.2 Power supply

#### Power consumption

Maximum 12 W

#### Supply voltage

- AC: 100-240 Vac 50/60 Hz -15% to +10%

#### Fuse

2 A, 350 V

### A.1.3 Start-up time

Approximately 30 seconds

## A.1.4 Write protection

Yes

## A.1.5 Memory card

Built-in memory card for logging function, up to 200.000 data points can be logged.

## A.1.6 Update rate (software)

10 Hz

## A.1.7 Supported HART® transmitters

### Supported Rosemount transmitters

- Rosemount 1208C Level and Flow Transmitter
- Rosemount 3408 Level Transmitter
- Rosemount 5408 Level Transmitter
- Rosemount 5300 Level Transmitter
- Rosemount 3300 Level Transmitter
- Rosemount 3100 Level Transmitter

### Generic support for HART transmitters

Support for data collection from other HART 5/7 level transmitters in accordance with HART practice

## A.1.8 Display

### Type

4.3 inch 480 x 272, backlit TFT LCD module color

### Output units

- Level and distance: ft., in., m, cm, mm, %
- Volume: ft<sup>3</sup>, US gallon, imperial gallon, barrel, m<sup>3</sup>, l
- Flow rate: ft<sup>3</sup>/s, ft<sup>3</sup>/min, ft<sup>3</sup>/h, ft<sup>3</sup>day, US gallon/min, US gallon/h, US gallon/day, UK gallon/min, UK gallon/h, UK gallon/day, Mega gallon/day, barrel/h, barrel/day, m<sup>3</sup>/s, m<sup>3</sup>/h, l/s, l/min, l/h

## A.1.9 Keypad

Six buttons; up, down, left, right, back, and enter

## A.1.10 Light emitting diode (LED)

One multi-colored LED for health status

## A.2 Electrical specifications

### A.2.1 Relay outputs

Up to six relay outputs  
250 Vac 8 A/24 Vdc 8 A resistive load

### A.2.2 Analog outputs

Up to three analog outputs

#### Signal range

4-20 mA

#### Accuracy

±0.02 mA (0.1% of 20 mA)

#### Resolution

12 bit

#### Maximum load

Load resistance must be in the interval: 120 Ω to 900 Ω

#### Power supply out

24 Vdc

#### Analog signal on alarm

The controller automatically and continuously performs self-diagnostic routines. If a failure or a calculated value error is detected, the analog signal will be driven offscale to alert the user. The fixed analog signal on alarm is user-configurable.

**Table A-3: Signal on Alarm**

Standard	High	Low
Rosemount standard	21.75 mA	3.75 mA
NAMUR NE43	22.5 mA	3.6 mA

#### Analog saturation levels

The controller will continue to set a current that corresponds to the calculated value until reaching the associated saturation limit (and then freeze).

**Table A-4: Saturation Levels**

Standard	High	Low
Rosemount standard	≥ 20.8 mA	≤ 3.9 mA
NAMUR NE43	≥ 20.5 mA	≤ 3.8 mA

## A.2.3 Digital inputs

Up to four digital inputs, for use with potential-free contacts

### Output voltage

14 V

### Output current

6 mA

## A.2.4 Sensor inputs

Up to two inputs, isolated from ground, for loop-powered/self-powered 4-20 mA/HART® transmitters

### Signal range

4-20 mA

### Accuracy

±0.02 mA (0.1% of 20 mA)

### Resolution

12 bit

### Load limitations

Minimum output voltage is 14.4 Vdc. The maximum loop resistance quoted ensures there will be at least 12 Vdc available at the transmitter.

**Table A-5: Minimum Terminal Output Voltages**

Load current (mA)	Rosemount 3490 terminal voltage (Vdc)	Maximum loop resistance (Ohms)
3.75	21.1	2427
4.0	21.1	2275
20.0	15.3	165
21.75	14.6	120
22.5	14.4	107

## A.2.5 Ethernet

Modbus® TCP connection to host system, and/or web interface access for service functions and data log download

- 10/100 Mbps
- RJ45 connector

## A.2.6 Isolation

### Sensor inputs to other terminals

1.8 kV

## A.3 Mechanical specifications

### A.3.1 Material selection

Emerson provides a variety of Rosemount products with various product options and configurations, including materials of construction that can be expected to perform well in a wide range of applications. The Rosemount product information presented is intended as a guide for the purchaser to make an appropriate selection for the application. It is the purchaser's sole responsibility to make a careful analysis of all process parameters (such as all chemical components, temperature, pressure, flow rate, abrasives, contaminants, etc.), when specifying product, materials, options, and components for the particular application. Emerson is not in a position to evaluate or guarantee the compatibility of the process fluid or other process parameters with the product, options, configuration, or materials of construction selected.

### A.3.2 Materials

#### Controller housing

Polybutylene Terephthalate/Polycarbonate (PBT)

#### Wall and pipe mounting kit

SST 316L

#### Weather protection

SST 316L

### A.3.3 Weight

3.7 lb (1.7 kg)

### A.3.4 Cable/conduit entries

- Seven M20 cable entries
- Support plate in stainless steel with M20 threads for cable glands or NPT adapters/conduit hubs

### A.3.5 Terminal connection type

Spring loaded terminals

## A.4 Environmental specifications

### A.4.1 Temperature limits

#### Ambient temperature

-40 to +140 °F (-40 to +60 °C)<sup>(3)</sup>

#### Storage temperature

-40 to +140 °F (-40 to +60 °C)

### A.4.2 Humidity

0 - 100% relative humidity

### A.4.3 Electrical safety

EN 61010-1:2010 (LVD)

### A.4.4 Ingress protection

- Enclosure meets IP66/IP67 according to IEC 60529
- Enclosure meets Type 4X according to UL50E

### A.4.5 Impact protection

Enclosure meets IK07

### A.4.6 Maximum vibration

Vibration according to IEC 61298-3, level "field with general application"

### A.4.7 Installation category

Overvoltage category II (according to IEC 60664-1)

### A.4.8 Pollution degree

Degree 2 according to IEC 61010-1

### A.4.9 Metrology sealing possibility

Yes

### A.4.10 Transient/built-in lightning protection

According to IEC 61326-1:2013

---

<sup>(3)</sup> Display reading: -4 to +140 °F (-20 to +60 °C).

### **Surge**

1 kV line-to-line

2 kV line-to-ground

### **Burst**

2 kV (5 % 50 ns, 5 kHz)

## **A.4.11 Electromagnetic compatibility (EMC)**

### **Emissions and immunity**

EN 61326-1

## **A.4.12 Maximum altitude**

6560 ft. (2000 m)

## A.5 Dimensional drawings

### A.5.1 Controller

Figure A-1: Rosemount 3490

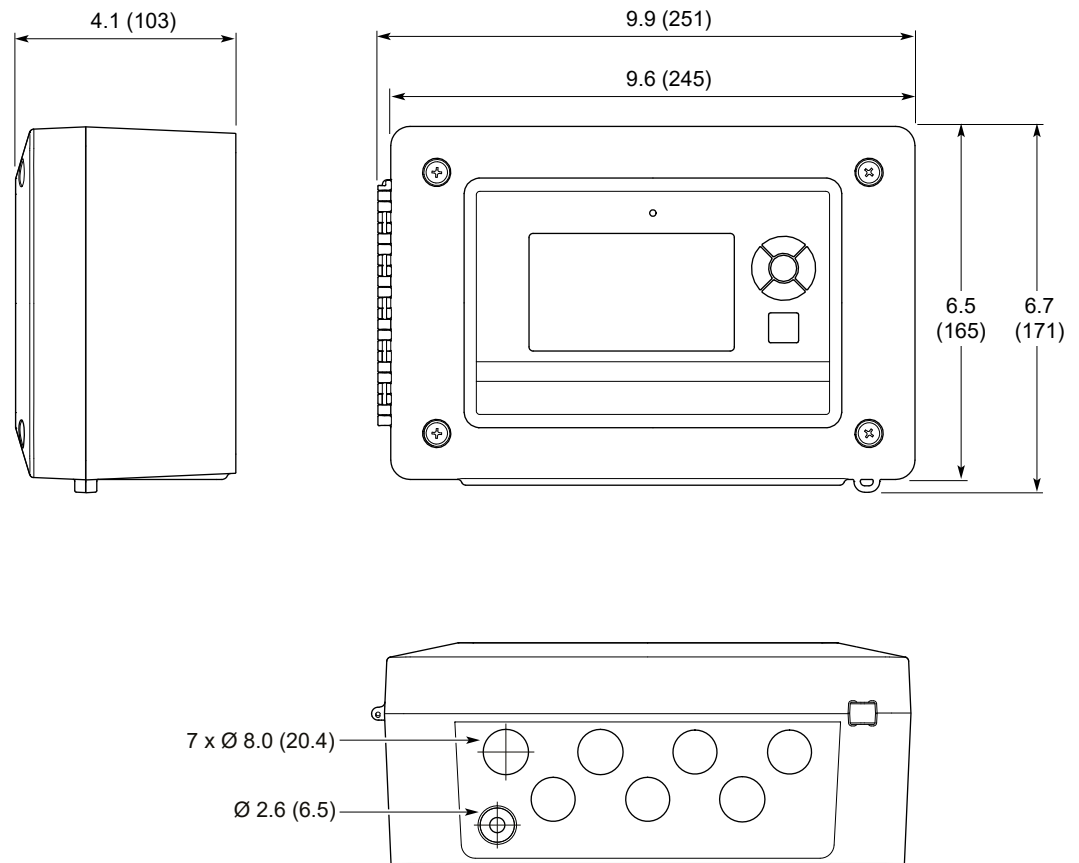

Dimensions are in inches (millimeters).

### A.5.2 Support plate

Figure A-2: Support Plate

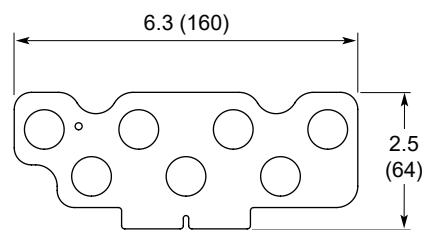

Dimensions are in inches (millimeters).



## A.5.3 Wall and pipe mounting kit

**Figure A-3: Mounting Bracket**

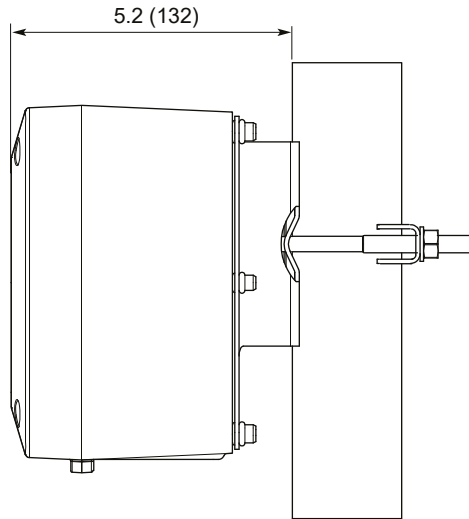

Dimensions are in inches (millimeters).

### Bracket hole pattern

**Figure A-4: Hole Pattern for Wall Mounting**

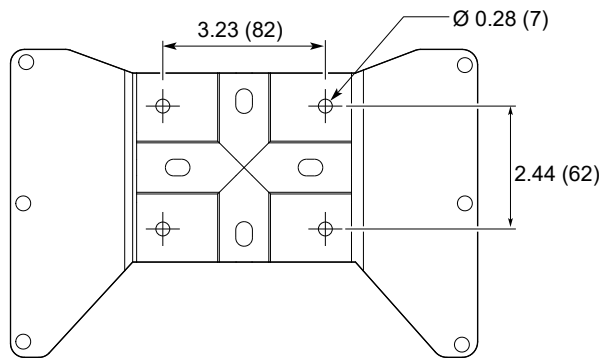

Dimensions are in inches (millimeters).

## A.5.4 Weather protection

**Figure A-5: Weather protection**

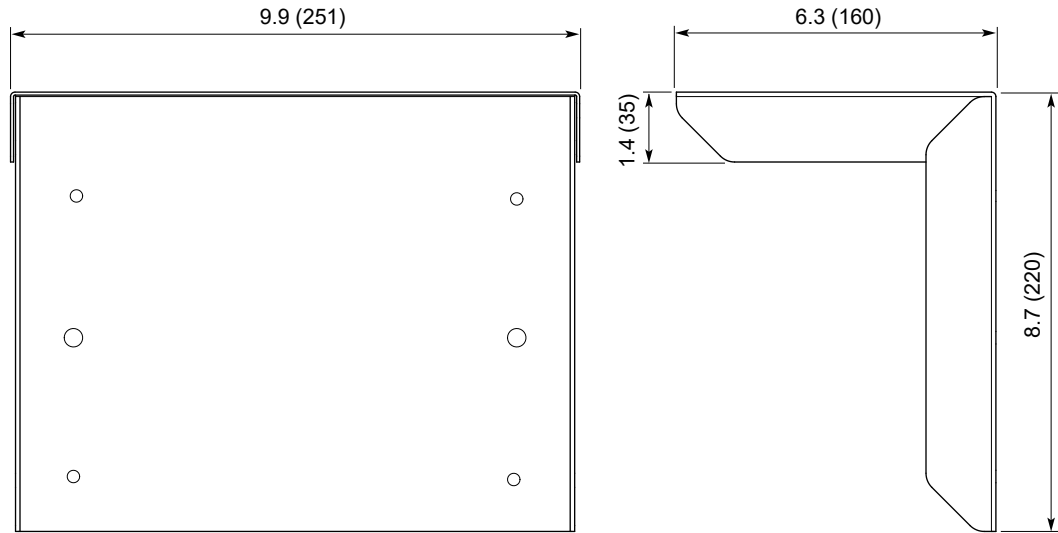

Dimensions are in inches (millimeters).

## B Configuration parameters

### B.1 Menu tree

The Rosemount 3490 lets you navigate in a menu structure as illustrated in [Figure B-1](#) and [Figure B-2](#).

Figure B-1: Rosemount 3490C Menu Tree

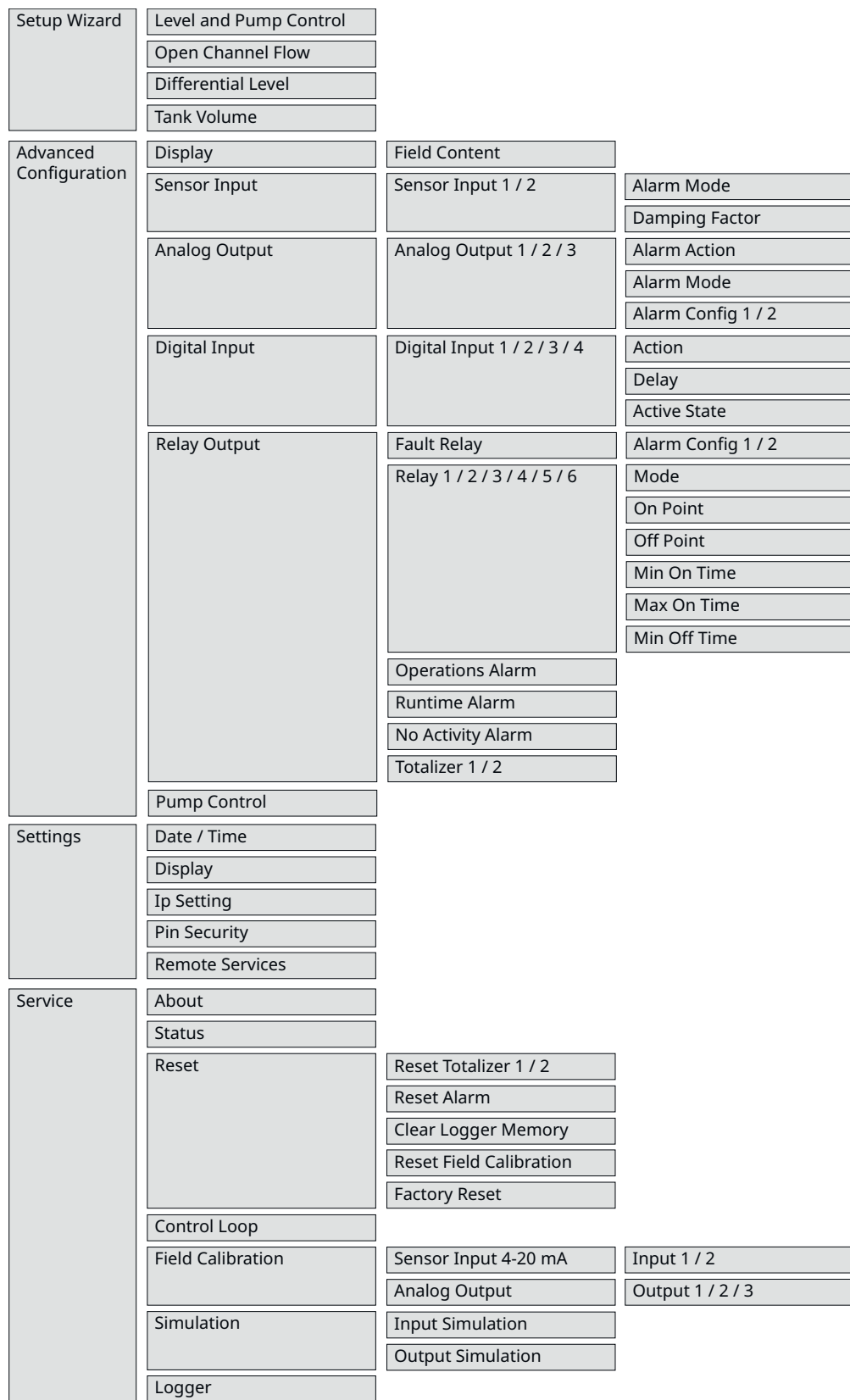
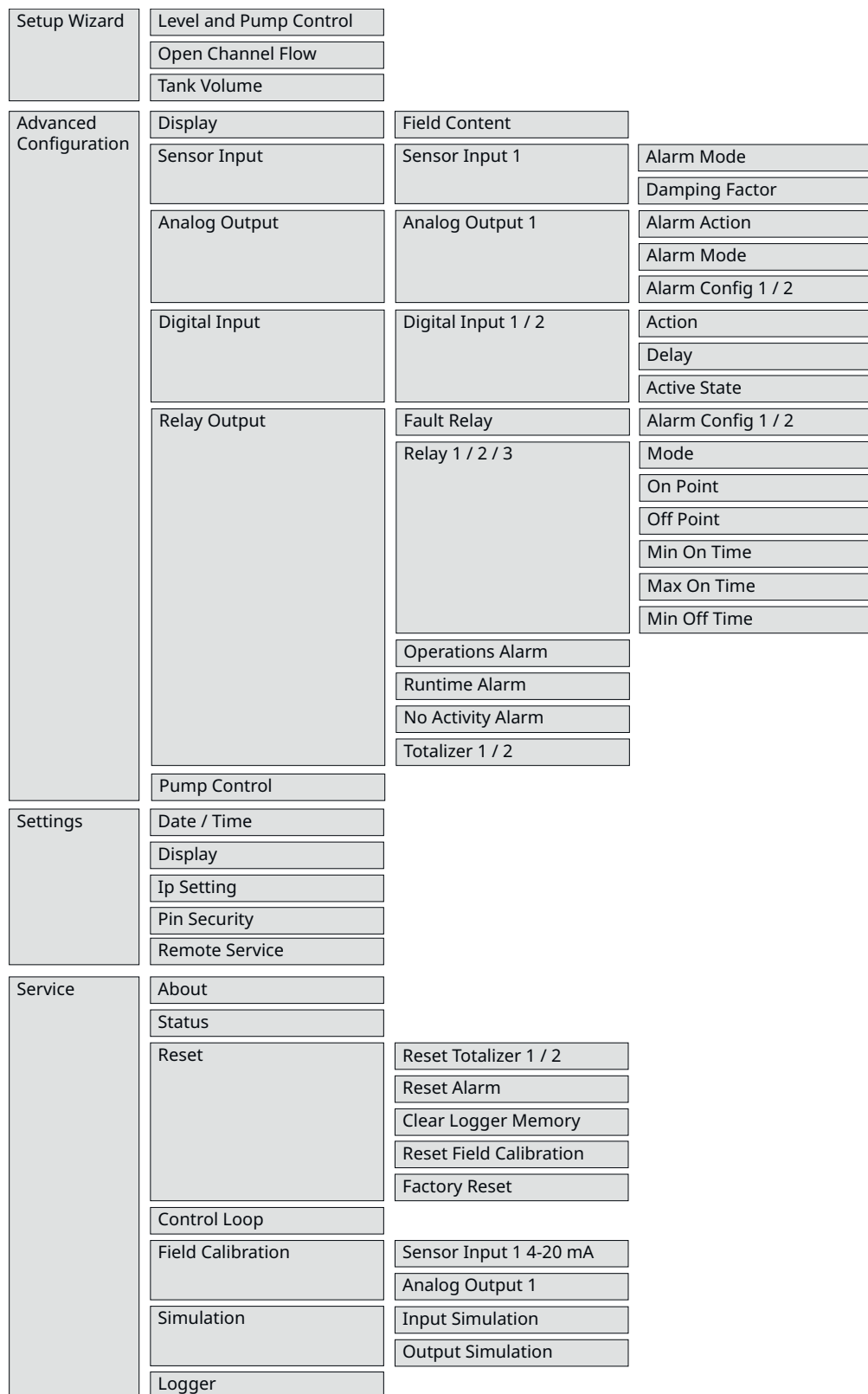

Figure B-2: Rosemount 3490A Menu Tree



## B.2 Display

### B.2.1 Field content

#### Middle, left, and right field content

The field content can be set up to display desired variables on the main screen.

**Figure B-3: Middle, left, and right field content**

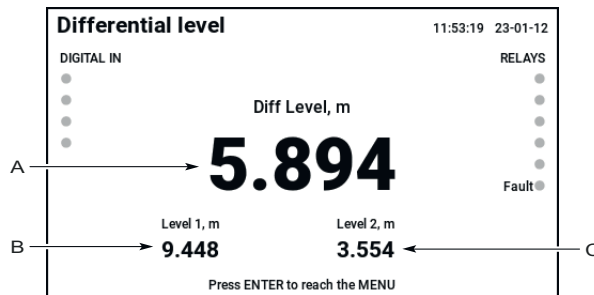

- A. Middle field content
- B. Left field content
- C. Right field content

Use the Display menu from Advanced configuration to setup the middle, left, and right field content.

**Table B-1: Field Content Options**

Option	Description
None	The selected display field is not used (default setting)
Analog Output 1	Set selected field to show Analog output 1 value
Analog Output 2	Set selected field to show Analog output 2 value
Analog Output 3	Set selected field to show Analog output 3 value
Totalizer 1	Set selected field to show Totalizer 1 value
Totalizer 2	Set selected field to show Totalizer 2 value
Sensor Input 1	Set selected field to show Sensor input 1 value
Sensor Input 2	Set selected field to show Sensor input 2 value
Rate of Change 1	Set selected field to show Rate of Change 1 value
Rate of Change 2	Set selected field to show Rate of Change 2 value
Rate of Change 3	Set selected field to show Rate of Change 3 value

#### Related information

- [Analog output](#)
- [Totalizer configuration](#)
- [Sensor input](#)

## Bargraph field content

The display field content bargraph can be setup according to user preference.

**Figure B-4: Bargraph field content**

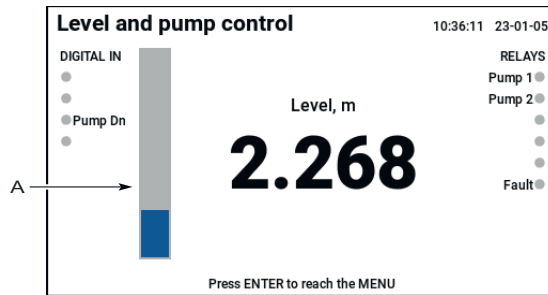

*A. Bargraph field content*

Use the Display menu from Advanced configuration to setup the bargraph field content.

**Table B-2: Bargraph Field Content Options**

Option	Description
None	Bargraph is not used (default setting)
Analog Output 1	Set bargraph to display Analog output 1 value
Analog Output 2	Set bargraph to display Analog output 2 value
Analog Output 3	Set bargraph to display Analog output 3 value
Analog Output 1 + 2	Set bargraph to display both Analog output 1 and Analog 2 values

### Related information

[Analog output](#)

## B.3 Sensor input

The application wizards will setup the majority of applications with no need of direct changes to sensor input parameters. A few additional sensor input settings can be configured using the Advanced configuration menu.

### B.3.1 Alarm mode

The Alarm mode is used to select sensor input alarm and saturation levels.

**Table B-3: Sensor Input Alarm Mode Options**

Option	Description
Rosemount	Set sensor input alarm and saturation levels according to Rosemount standard (default setting).
NAMUR	Set sensor input alarm and saturation levels according to NAMUR standard.

#### Related information

[Analog signal on alarm](#)

[Analog saturation levels](#)

### B.3.2 Damping factor

The analog measurement is input to the controller as a 4-20 mA signal, and pass through a damping stage to smooth out large jumps in signals.

**Table B-4: Sensor Input Damping Factor Settings**

Option	Description
Damping factor	The damping can be adjusted by changing the time setting in seconds. Limits: 0-99.9 seconds. Default: 5 seconds.



## B.4 Analog output

The current output is for transmitting the controller calculated value as a 4–20 mA signal. [Table B-5](#) displays transmitted calculated value for each application wizard.

**Table B-5: Calculated Values for Analog Outputs**

Application Wizard	Analog Output 1	Analog Output 2	Analog Output 3
Level and pump control	Calculated level	N/A	N/A
Open channel flow	Calculated flow	N/A	N/A
Differential level	Calculated level for Sensor input 1	Calculated level for Sensor input 2	Calculated differential level
Tank Volume	Calculated volume	N/A	N/A

The output is calculated by using the range values, according to [Range values](#).

### B.4.1 Range values

The Lower and Upper range values are used to set the source values that correspond to the analog output values 4 mA and 20 mA.

**Table B-6: Analog Output Range Values**

Parameter	Description
Lower range value	Select the minimum controller calculated value to be represented by a 4 mA signal. Default: 0.0
Upper range value	Select the maximum controller calculated value to be represented by a 20 mA signal. Default: 100.0

[Figure B-5](#) displays an example with range values 0 to 10 meters. Therefore, a controller calculated value of 5 meters would be output as a 12 mA signal by the analog output.

**Figure B-5: Example: Controller Calculated Value Range 0 to 10 Meters**

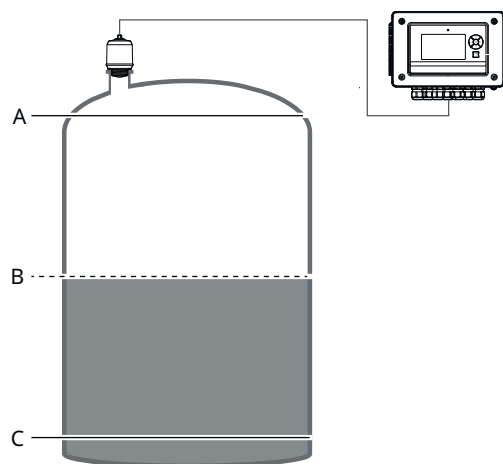

- A. Upper range value: 10 meters represented by 20 mA
- B. 5 meters represented by 12 mA
- C. Lower range value: 0 meters represented by 4 mA

## B.4.2 Alarm action

The Alarm action is used to determine how an active alarm is indicated on the current output.

**Table B-7: Analog Output Alarm Action Options**

Option	Description
Set 3.6 mA (NAMUR)	Fix current output to 3.6 mA to force a low current limit alarm (default setting).
Set 3.75 mA (Rosemount)	Fix current output to 3.75 mA to force a low current limit alarm.
Hold current output	Freeze the current output at the present value.
Set 21.0 mA	Fix current output to 21 mA to force high current limit alarm.
Set 21.75 mA (Rosemount)	Fix current output to 21.75 mA to force high current limit alarm.
Set 22.5 mA (NAMUR)	Fix current output to 22.5 mA to force high current limit alarm.

### Related information

[Analog signal on alarm](#)

## B.4.3 Alarm mode

The controller will continue to set a current that corresponds with the calculated value until reaching the upper/lower limit i.e. saturated (and then freeze).

**Table B-8: Analog Output Alarm Mode Options**

Option	Description
Rosemount	Set analog output saturation levels according to Rosemount standard (default setting).
NAMUR	Set analog output saturation levels according to NAMUR standard.

### Related information

[Analog saturation levels](#)

## B.4.4 Alarm configuration

The controller can detect the alarm conditions presented in [Alarm conditions configuration](#). These alarms may be externally signaled using the current outputs.

### Related information

[Configure alarms for analog output](#)

## B.5 Digital inputs

For applications where the controller functionality is linked to other external events, there are up to four digital input ports for accepting contact closure signals. The digital inputs can be individually setup to perform various control actions (e.g. raise an alarm) whenever activated.

### B.5.1 Digital input actions

The digital inputs can be setup to perform an action whenever they are triggered. The digital input statuses are shown on the left-hand side of the display.

Available digital input actions are listed in [Table B-9](#).

**Table B-9: Digital Input Action Settings**

Option	Description
No action	The digital input has no allocated action (default setting).
Alarm	An alarm is activated for the specific digital input.
Hold Totalizer 1 Hold Totalizer 2	The selected totalizer is frozen.
Hold Sensor Input 1 Value Hold Sensor Input 2 Value Hold Diff Level Value	The calculated value is prevented from being updated.
Pump Down	A Pump down operation is invoked.
Protect Totalizer 1 Protect Totalizer 2 Protect Totalizers	Selected totalizer is prevented from being reset.
Reset Totalizer1 Reset Totalizer2	Selected totalizer is reset.
Bad Data Trigger	When the digital input is activated, data is flagged as a 'bad sample' in the data logger.
Write Protection	The controller is write-protected while digital input is active.
Lock Control Loop	All calculated values are frozen.
Alarm Suppression	If an alarm condition is present when the digital input is active, a message is displayed indicating the alarm is being overridden. Alarm relay is held on.

#### Related information

[Configure digital input action](#)

### B.5.2 Delay

If a delay is needed before an action is performed, the Delay option can be set for that specific digital input. The action is carried out after the preset time expires.

**Table B-10: Digital Input Delay Settings**

Option	Description
Value	Set desired digital input delay in seconds. Limits: 0-9 seconds. Default: 0 seconds.

**Related information**

[Set digital input delay](#)

### B.5.3 Active state

The logic of a digital input for triggering an action can be changed by using the Active state option.

**Table B-11: Digital Input Active State Settings**

Option	Description
Closed	Action is triggered when the voltage-free contact is closed (default setting).
Open	Action is triggered when the voltage-free contact is open.

**Related information**

[Set digital input active state](#)

## B.6 Relay output

The controller provides up to six freely assignable relay outputs. By default, one relay is a fault relay but can be assigned to a control duty. The other relays are available for controlling pumps or alarms.

### B.6.1 Fault relay

Fault relays de-energize while there is an internal controller fault, and re-energize when the fault condition no longer applies.

#### Alarm configuration

The controller can detect the alarm conditions listed in [Alarm conditions configuration](#). These alarms may be externally signaled using the fault relay output.

#### Related information

[Configure alarms for fault relay](#)

### B.6.2 On point

The On Point of a relay function sets the trigger level that the measured value must pass in order to energize the relay. The type of comparison (greater than or less than) between On Point and measured value differs depending on the relay function.

For example, in a basic emptying application, the On Point is set to be greater than the Off Point. The applicable relay energizes when the measured value exceeds the On Point and de-energizes when the value drops below the Off Point. On the other hand, in a basic filling application, the On Point is set to be less than the Off Point. The applicable relay energizes when the measured value falls below the On Point and de-energizes when the value exceeds the Off Point.

#### Related information

[Off point](#)

### B.6.3 Off point

The Off Point of a relay function sets the trigger level that the measured value must pass in order to de-energize the relay again. The type of comparison (greater than or less than) between Off Point and measured value differs depending on the relay function.

For example, in a basic emptying application, the On Point is set to be greater than the Off Point. The applicable relay energizes when the measured value exceeds the On Point and de-energizes when the value drops below the Off Point. On the other hand, in a basic filling application, the On Point is set to be less than the Off Point. The applicable relay energizes when the measured value falls below the On Point and de-energizes when the value exceeds the Off Point.

#### Related information

[On point](#)

## B.6.4 Min on time

This is an optional override (safeguard) to allow sufficient time for connected equipment to respond. The Min on time option defines the minimum time (in seconds) that a relay will stay energized before de-energizing. Default value is 0 seconds.

## B.6.5 Max on time

This is an optional override (safeguard) to prevent overuse of connected equipment. The Max on time option defines the maximum time (in seconds) that a relay will stay energized before de-energizing. Default value is 0 seconds.

## B.6.6 Min off time

This is an optional override (safeguard) to avoid overuse of connected equipment. The Min off time option defines the minimum time (in seconds) that a relay will stay de-energized before energizing. Default value is 0 seconds.

This option is only available through the advanced configuration menu.

## B.6.7 Operations alarm

The Operations alarm is active when the number of operations performed by a monitored relay exceeds its user defined limit of number of operations.

For the Operations alarm condition to be indicated by an analog output and/or a fault relay, it must be configured using the Advanced configuration menu.

**Table B-12: Operations Alarm Settings**

Parameter	Description
Limit	Set limit for number of operations performed by selected relay. Default value: 0.
Relay Select	Select desired relay for the operations alarm monitoring. Default setting: Disabled (function disabled, no relay selected).

## B.6.8 Runtime alarm

The Runtime alarm is active when a monitored relay has exceeded its user-defined limit for time being energized.

For the Runtime alarm to be indicated by an analog output and/or a fault relay, it must be configured using the Advanced configuration menu.

**Table B-13: Runtime Alarm Settings**

Parameter	Description
Limit	Set time limit for selected relay to be energized, in seconds. Default value: 0 s.
Relay Select	Select desired relay for the Runtime alarm monitoring. Default setting: Disabled (function disabled, no relay selected).

## B.6.9 No activity alarm

The No activity alarm is active when the monitored relay has exceeded its user-defined limit for time being inactive. The alarm condition is cleared when the relay is energized.

For the No activity alarm to be indicated by an analog output and/or a fault relay, it must be configured using the Advanced configuration menu.

**Table B-14: No Activity Alarm Settings**

Parameter	Description
Limit	Set time limit for selected relay to be inactive, in seconds. Default value: 0 s.
Relay Select	Select desired relay for the No activity alarm monitoring. Default setting: Disabled (function disabled, no relay selected).

## B.6.10 Totalizer relay output

A totalizer relay can output a pulse for each time that the internal totalizer count increments. If the totalizer count is running faster than the relay can produce pulses, an internal accumulator stores the excess pulses. The stored excess pulses are output by the totalizer relay after the totalizer count rate reduces.

### Pulse width

The Pulse width parameter is used to set the time duration that the relay is active for. The Pulse width value applies to both totalizer and sampler relay outputs.

For example, a Pulse width set to 50 ms means that the relay will pulse for 50 ms.

**Table B-15: Pulse width settings**

Parameter	Description
Pulse width value	Set the time duration that the relay is active for, in milliseconds. Default value: 100 ms.

### Sampler factor

A sampler relay outputs pulses at a slower rate than a totalizer relay. The Sampler factor parameter defines the pulse frequency for a sampler relay output.

For example, a Sampler factor set to Times100 means that the sampler relay outputs a single pulse for every 100th increment to the totalizer count.

**Table B-16: Sampler Factor Settings**

Parameter	Description
None	No Sampler factor used (default setting).
Times1	The sampler relay outputs a single pulse for every increment to the totalizer count.
Times10	The sampler relay outputs a single pulse for every 10th increment to the totalizer count.
Times100	The sampler relay outputs a single pulse for every 100th increment to the totalizer count.
Times1000	The sampler relay outputs a single pulse for every 1000th increment to the totalizer count.

**Related information**

[Totalizer relay mode](#)

[Sampler relay mode](#)



## B.7 Relay mode

The relay mode is used to assign a particular function to a specific relay output. Relay modes automatically enable and disable special control functions, special alarms and totalizing.

The relay mode configuration forms a part of the setup wizards. In addition, relay modes can be setup using the Advanced configuration menu.

### B.7.1 High alarm

The high alarm relay mode uses the On Point and Off Point settings to define a high alarm for the calculated value. The relay is energized when the value exceeds the On Point value and remains energized until the value drops below the Off Point value.

**Figure B-6: Example: High Alarm**

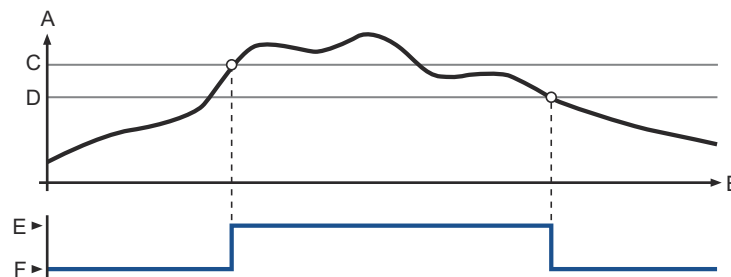

- A. Level
- B. Time
- C. On Point
- D. Off Point
- E. Relay energized
- F. Relay de-energized

#### Tip

By setting the Off Point slightly below the On Point, you achieve a hysteresis function for the high alarm to avoid it going on and off if the calculated value fluctuates near the On Point value.

For the differential level application, you can enable high alarm relays for the level 1 and level 2 measurement values in addition to the calculated differential level.

#### Related information

- [On point](#)
- [Off point](#)

## B.7.2 Low alarm

The low alarm relay mode uses the On Point and Off Point settings to define a low alarm for the calculated value. The relay is energized when the value falls below the On Point value and remains energized until the value exceeds the Off Point value.

**Figure B-7: Example: Low Alarm**

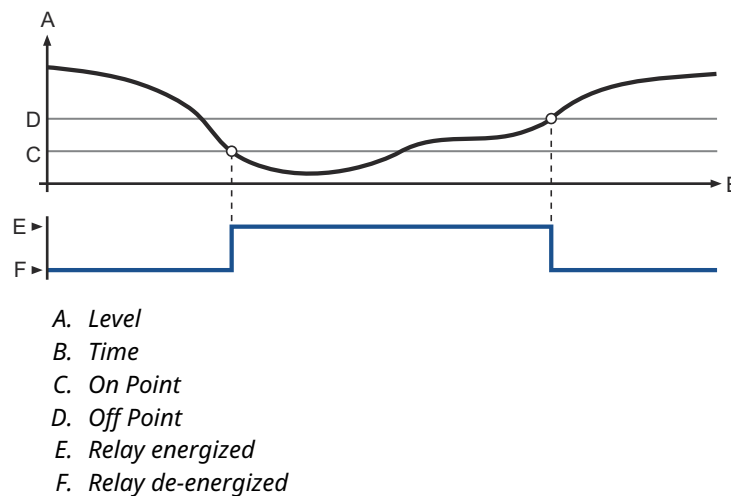

### Tip

By setting the Off Point slightly above the On Point, you achieve a hysteresis function for the low alarm to avoid it going on and off if the calculated value fluctuates near the On Point value.

For the differential level application, you can enable low alarm relays for the level 1 and level 2 measurement values in addition to the calculated differential level.

### Related information

[On point](#)

[Off point](#)

## B.7.3 Rate of change alarm

A rate of change for the main controller value is calculated every 5 seconds in units of main value per minute, e.g.  $\text{m}^3/\text{min}$  if main value unit is  $\text{m}^3$ .

The rate of change alarm mode uses the On Point and Off Point settings to define the normal operating range for the rate of change. The limits are set in units of main value per minute. The relay is energized while the rate of change exceeds the On Point value or while it is below the Off Point value.

**Figure B-8: Example: Rate of Change Alarm**

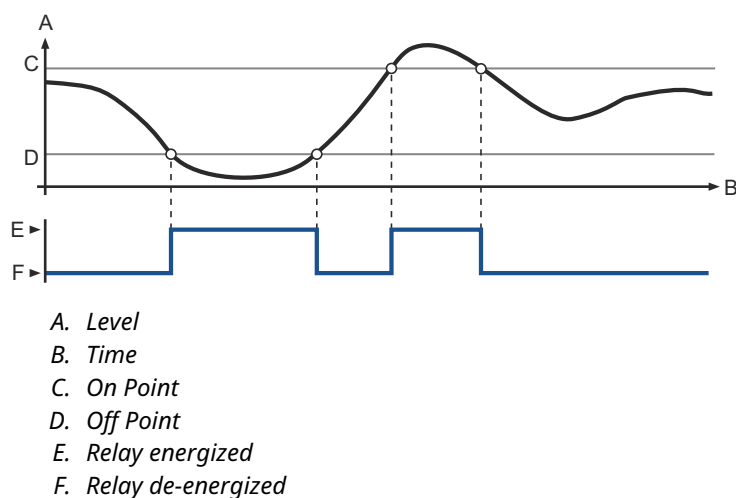

Typically, where the main calculated value is a liquid level or volume measurement, the RoC relay can be used to warn of a quickly rising or falling liquid level.

For the Differential Level application, you can enable RoC alarm relays for the level 1 and level 2 measurement values in addition to the calculated differential level.

**Related information**

[On point](#)

[Off point](#)

## B.7.4

### Out-of-limits alarm

This relay mode uses the On Point and Off Point settings to define the normal operating range for the calculated value. Limits are set in the same unit as the calculated value. The relay is energized while the calculated value exceeds the On Point or while it is below the Off Point.

**Figure B-9: Example: Out-of-Limits Alarm**

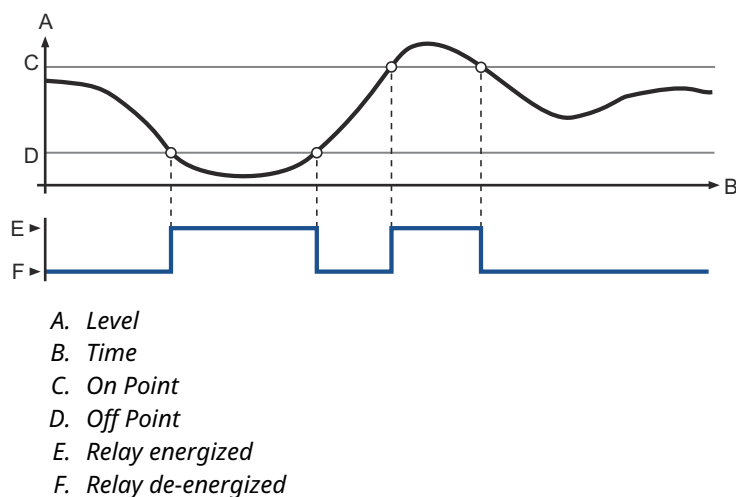

For the Differential Level application, you can enable Out-of-limits alarm relays for the Level 1 and Level 2 measurement values in addition to the calculated differential level.

**Related information**

[On point](#)  
[Off point](#)

## B.7.5 Fault

The selected relay is set function as a fault relay.

## B.7.6 Not in use

The selected relay is not used.

## B.7.7 Follow digital input

A relay can be configured to be energized while a specific digital input is active, or several digital inputs are all active.

## B.7.8 Totalizer relay mode

A totalizer relay can output a pulse for each time that the internal totalizer count increments. The totalizer relay mode is used to set the selected relay to either Totalizer 1 (accumulating) or Totalizer 2 (daily).

**Table B-17: Totalizer Relay Mode Options**

Option	Description
Totalizer 1	Set the selected relay to Totalizer 1 (accumulating) relay mode.
Totalizer 2	Set the selected relay to Totalizer 2 (daily) relay mode.

**Related information**

[Totalizer relay output](#)

## B.7.9 Sampler relay mode

A sampler relay outputs pulses at a slower rate than a totalizer relay. The sampler relay can be used as a coarse totalizer or as a trigger to an external event. The pulse width is the same as selected for the totalizer relay.

The sampler relay mode is used to set the selected relay to either Sampler 1 (accumulating) or Sampler 2 (daily).

**Table B-18: Sampler Relay Mode Options**

Option	Description
Sampler 1	Set the selected relay to Sampler 1 (accumulating) relay mode.
Sampler 2	Set the selected relay to Sampler 2 (daily) relay mode.

**Related information**

[Totalizer relay output](#)

### B.7.10      On

A relay where the relay mode is set to On, is always energized.

### B.7.11      Off

A relay where the relay mode is set to Off, is always de-energized.

## B.8 Pump modes

### B.8.1 Standby, split off point

This function requires two or more relays set to Stby, split off mode. Only one of these relays is energized at any one time and the others are on standby to take over when needed. The example below illustrates how the function works.

#### Example: Wet well/lift station application (emptying operation due to rising level)

Consider an application with two relays, connected to individual pumps in a wet well. The calculated value is a liquid level measurement in meters. The relays use their on and off parameters, according to [Table B-19](#).

**Table B-19: Example Settings**

Parameter	Value
Pump 1 (relay 1) on	5 m
Pump 1 (relay 1) off	2 m
Pump 2 (relay 2) on	8 m
Pump 2 (relay 2) off	5 m

**Figure B-10: Example: Wet Well/Lift Station Application**

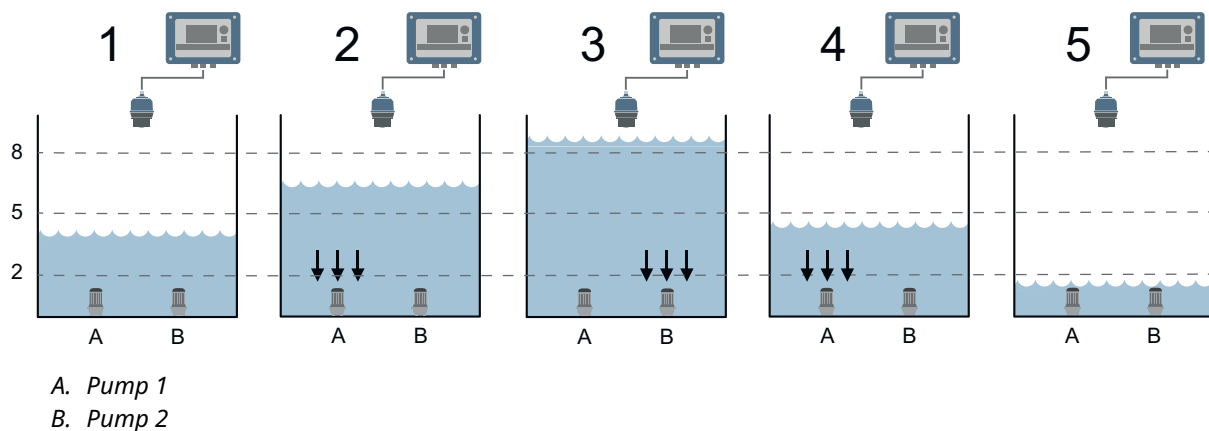

1. Both pump 1 and pump 2 are off because the liquid level is at a satisfactory level, below 5 m.
2. When the level exceeds 5 m, relay 1 is energized to start pump 1.
3. When the level exceeds 8 m, relay 2 is energized to start pump 2. Relay 1 is de-energized to switch off pump 1.
4. When the level falls to below 5 m, relay 2 de-energizes to switch off pump 2. Relay 1 is energized to switch on pump 1.
5. When the level falls below 2 m, relay 1 de-energizes to switch off pump 1.

#### Note

If pump 1 keeps the level below 8 m, it would stay switched on until the level is 2 m.

## B.8.2 Standby, common off

This function requires two or more relays set to Stby, com off mode. Only one of these relays is energized at any one time and the others are on standby to take over when needed. The example below illustrates how the function works.

### Example: Wet well application (emptying operation due to rising level)

Consider an application with two relays, connected to individual pumps in a wet well. The calculated value is a liquid level measurement in meters. The relays use their on and off parameters, according to [Table B-20](#).

**Table B-20: Example Settings**

Parameter	Value
Pump 1 (relay 1) on	5 m
Pump 2 (relay 2) on	8 m
Pump common off	2 m

**Figure B-11: Example: Wet Well Application**

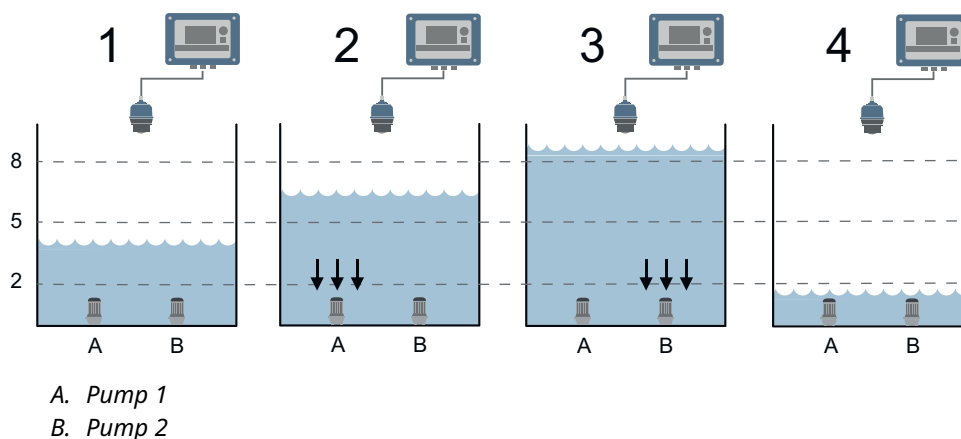

1. Both pump 1 and pump 2 are off because the liquid level is at a satisfactory level, below 5 m.
2. When the level exceeds 5 m, relay 1 is energized to start pump 1.
3. If the level exceeds 8 m, relay 2 is energized to start pump 2. Relay 1 is de-energized to switch off pump 1.
4. Pump 2 continues to pump until the level falls below 2 m, at which relay 2 will de-energize to switch off pump 2. (Pump 1 is already switched off).

### Note

If pump 1 keeps the level below 8 m, it would stay switched on until the level is 2 m.

### B.8.3 Assist with split off points

This function requires two or more relays set to Assist split off mode. Two or more of these relays can be energized at the same time (assisting), and they all de-energize at a split off points. The example below illustrates how the function works.

#### Example: Wet well/lift station application (emptying operation due to rising level)

Consider an application with two relays, connected to individual pumps in a wet well. The calculated value is a liquid level measurement in meters. The relays use their on and off parameters, according to [Table B-21](#).

**Table B-21: Example Settings**

Parameter	Value
Pump 1 (relay 1) on	5 m
Pump 1 (relay 1) off	2 m
Pump 2 (relay 2) on	8 m
Pump 2 (relay 2) off	4 m

**Figure B-12: Example: Wet Well/Lift Station Application**

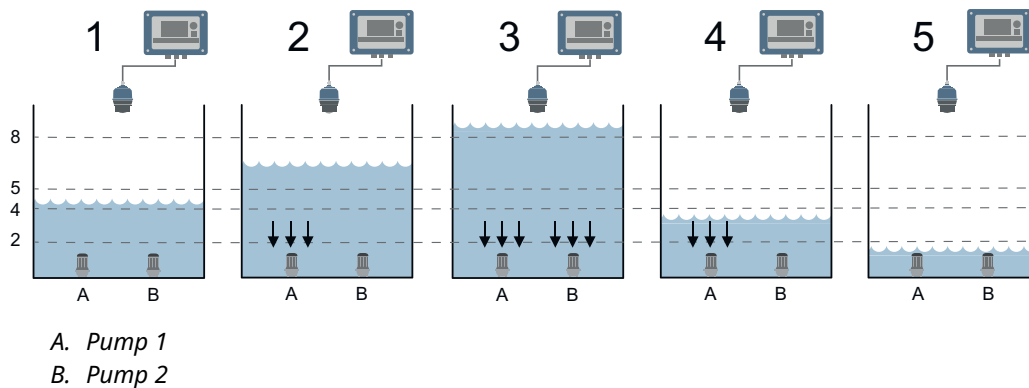

1. Both pump 1 and pump 2 are off because the liquid level is at a satisfactory level, below 5 m.
2. When the level exceeds 5 m, relay 1 is energized to start pump 1.
3. When the level exceeds 8 m, relay 2 is energized to start pump 2 and assist pump 1. Relay 1 stays energized to keep pump 1 pumping.
4. When the level falls to below 4 m, relay 2 de-energizes to switch off pump 2. Relay 1 stays energized to keep pump 1 pumping.
5. When the level falls to below 2 m, relay 1 de-energizes to switch off pump 1.

#### Note

If pump 1 keeps the level below 8 m, it would stay switched on until the level is 2 m.



## B.8.4 Assist relay with common off points

This function requires two or more relays set to Assist com off mode. Two or more of these relays can be energized at the same time (assisting), and they all de-energize at a common off point. The example below illustrates how the function works.

### Example: Wet well/lift station application (emptying operation due to rising level)

Consider an application with two relays, connected to individual pumps in a wet well/lift station. The calculated value is a liquid level measurement in meters. The relays use their on and off parameters, according to Table B-22.

**Table B-22: Example Settings**

Parameter	Value
Pump 1 (relay 1) on	5 m
Pump 2 (relay 2) on	8 m
Pump common off	2 m

**Figure B-13: Example: Wet Well/Lift Station Application**

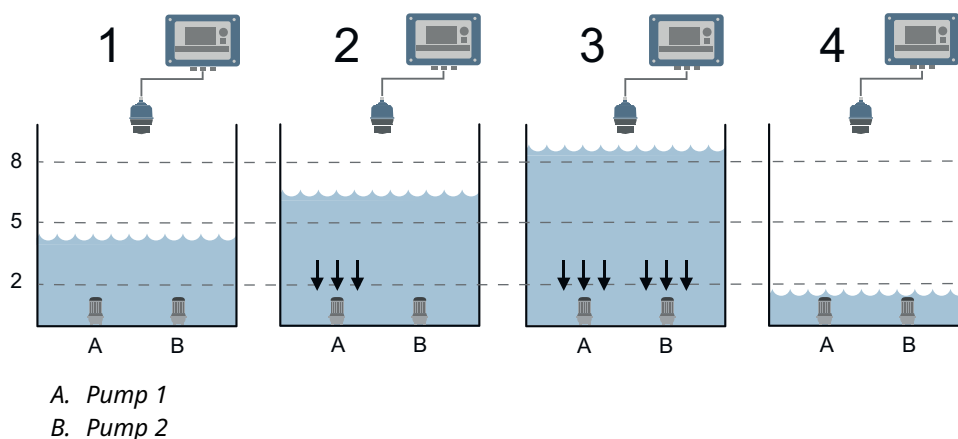

1. Both pump 1 and pump 2 are off because the liquid level is at a satisfactory level, below 5 m.
2. When the level exceeds 5 m, relay 1 is energized to start pump 1.
3. When the level exceeds 8 m, relay 2 is energized to start pump 2 and assist pump 1. Relay 1 stays energized to keep pump 1 pumping.
4. Pump 1 and pump 2 continue to pump down until the level falls to below 2 m, at which both relays de-energize to switch off both pumps.

#### Note

If pump 1 had kept the level below 8 m, it would stay switched on until the level is 2 m.

## B.8.5 Individual pump

The individual pump function may be used to start/stop pumps or open/close valves at different level points. By using the On Point/Off Point control relay settings, the relay energizes at one level point and then de-energizes at a different level point.

**Related information**

[On point](#)

[Off point](#)

## B.9 Pump control

### B.9.1 Scum line prevent

Scum line prevention is used with a pump control application to provide a small variance in the start and stop level for the pump. It will help to prevent a build-up of scum on the side of a wet well or sump.

This pump control function divides the user-defined Variation value in 10 steps and changes the On/Off points with 1/10 of its value every time the pump is turned on.

**Table B-23: Scum Line Prevent Settings**

Parameter	Description
Variation	The variation parameter defines a maximum variance in the On Points and Off Points of selected relays. The Variation value is entered in the On/Off Point units, spaced in ten equal increments within the On Point and Off Point limits. Each time the selected relays de-energize, the variance moves on an increment.

#### Related information

[On point](#)  
[Off point](#)

### B.9.2 Energy saving

The Energy saving function is used to schedule the time of day at which selected relay(s) will energize until each relay Off Point is reached.

**Table B-24: Energy Saving Settings**

Option	Description
Pump select	Select desired relay for energy saving, multiple relays can be selected. Default setting: Disabled (function disabled, no relay selected).
Start time	Schedule start time for the energy saving function. Enter start time in seconds from 00:00. Default value: 0 s.

#### Related information

[Off point](#)

## B.9.3 Pump down

The Pump down function is used to clear a sump of sludge that may have collected at the bottom.

In a pump down application, the lowest relay Off Point ('pump off' level) is normally a fixed level above the Transmitter Bottom Reference point. However, it is sometimes required to make the pumps continue to run for a period past the Off Point or run down the level to the Transmitter Bottom Reference point.

The pump down operation automatically stops when the controller calculated value reaches the user-defined Off value, or after the user-defined Duration, whichever is the shorter period.

Pump down can be initiated automatically at preset intervals. A digital input can also initiate pump down at any time and this will reset the interval before the next pump down.

**Table B-25: Pump Down Settings**

Parameter	Description
Pump select	Select desired relay for the pump down operation, multiple relays can be selected. Default setting: Disabled (function disabled, no relay selected).
Interval	Set interval time between function activation.
Duration	Set maximum time (minutes) the pump down function will be active. Default value: 20 minutes.
Off value	Set the Off value to the level that the controller calculated value shall reach for the pump to be turned off. Same units as configured for the controller calculated value.

### Note

The pump down function should only be used for a pump-out station. Do not use this function for a pump-in station.

### Related information

[Digital input actions](#)

[Off point](#)

## B.9.4 Rising level

The Rising level function supervises that the pump really causes level to decrease. This alarm requires a minimum of one Assist or Standby mode relay. If any Standby relay is energized, monitoring of the rising level is activated. For Assist relays, they must all be energized for monitoring of the rising level to be activated.

A timed delay starts after the monitoring is activated. If the level is still rising after the delay time has expired, the result is an activated Rising level alarm. The alarm is deactivated as soon as the level starts falling.

For the Rising level alarm to be indicated by an analog output and/or a fault relay, that specific alarm condition must be configured using the Advanced configuration menu.

**Table B-26: Rising Level Settings**

Parameter	Description
Alarm delay	Set Alarm delay time for rising level monitoring, in seconds. Default value: 0 s.

## B.9.5 Pump efficiency

The Pump efficiency function allows an alarm to be indicated if the calculated pump efficiency falls below a user-defined limit.

The pump efficiency calculation is based on the rate of change of the calculated value and is independently monitored for each selected relay. While the calculated pump efficiency is below the Limit value, the Pump efficiency alarm is active. The alarm is deactivated as soon as the calculated pump efficiency rises above the defined limit by 5 percent or more.

For the Pump efficiency alarm to be indicated by an analog output and/or a fault relay, that specific alarm condition must be configured using the Advanced configuration menu.

**Table B-27: Pump Efficiency Settings**

Parameter	Description
Pump select	Select desired relay for pump efficiency limit monitoring operation, multiple relays can be selected. Default setting: Disabled (function disabled, no relay selected).
Limit	Define the Limit value (in percent) for the pump efficiency. While the calculated pump efficiency is below the Limit value, the Pump efficiency alarm is active. The pump efficiency calculation is based on the rate of change of the controller and is independently monitored for each selected relay. Default value: 0 percent.

## B.9.6 Auto sequence mode

The Auto sequence mode is an optional automatic rotation of the leading (most used) relay that can be applied to Assist or Standby mode relays. To use this option, two or more relays must have the same relay mode. The lowest numbered relay is initially the lead relay.

The rotation can be initiated after a specific number of starts, or at a specific time of day. Auto sequence mode is only available through the Level and pump control setup wizard.

**Table B-28: Auto Sequence Mode Settings**

Option	Description
None	No automatic rotation (default setting).
Starts	Use the Starts option to define the number of starts before applying an auto sequence to rotate the 'lead' to the next relay. Default: 0. Limits: 0-9.
On time	Use the On time option to schedule a time of day for the auto sequence to rotate the 'lead' to the next relay. Default: 00:00 (hh:mm). Limits: 00:00-23:59.

### Related information

[Standby, split off point](#)

[Standby, common off](#)

[Assist with split off points](#)

Assist relay with common off points

## B.10 Alarm conditions configuration

The controller can detect the alarm conditions listed in [Table B-29](#). Alarms are indicated using fault relay outputs and/or analog current outputs.

**Table B-29: Alarm Configuration 1 Conditions**

Option	Description	Factory default
Sensor Input 1 Open Loop Sensor Input 2 Open Loop	Open loop detected for Sensor Input connection	On
Sensor Input 1 Failure Low Sensor Input 2 Failure Low	The transmitter connected to Sensor Input indicates failure low current	On
Sensor Input 1 Failure High Sensor Input 2 Failure High	The transmitter connected to Sensor Input indicates failure high current	On
Sensor Input 1 Short Circuit Sensor Input 2 Short Circuit	Short-circuit detected for Sensor Input connection	On
Sensor Input 1 Saturated Low Sensor Input 2 Saturated Low	The transmitter connected to Sensor Input indicates saturation low current	Off
Sensor Input 1 Saturated High Sensor Input 2 Saturated High	The transmitter connected to Sensor Input indicates saturation high current	Off
HART Input 1 No Response HART Input 2 No Response	The HART transmitter connected to Sensor Input is not responding	On
HART Input 1 Invalid Value HART Input 2 Invalid Value	The HART transmitter connected to Sensor Input reports invalid measurement value	On
HART Input 1 Out Of Limit HART Input 2 Out Of Limit	The HART transmitter connected to Sensor Input reports measurement outside sensor limits	Off
HART Input 1 Modem Error HART Input 2 Modem Error	An electronics error has occurred	Off
Analog Output 1 Out Of Range Analog Output 2 Out Of Range Analog Output 3 Out Of Range	The configured span for analog output is too small	Off
Digital Input 1 Alarm Digital Input 2 Alarm Digital Input 3 Alarm Digital Input 4 Alarm	Digital Input indicates fault condition	On

**Table B-30: Alarm Configuration 2 Conditions**

Option	Description	Factory default
Control Loop Not Configured	Incomplete or missing control loop configuration	Off
Control Loop Not Running	Controller is in configuration mode and is not reporting actual information	Off
Configuration Error	The controller has detected a configuration error	On
Variable Out Of Range	The level measurement is outside the configured range for volume or flow	Off

**Table B-30: Alarm Configuration 2 Conditions (continued)**

Option	Description	Factory default
Simulation Mode Active	The controller is in simulation mode and is not reporting actual information	Off
Relay No Activity Alarm	The configured relay has exceeded its user defined limit for time being inactive	Off
Relay Operations Alarm	The configured Relay has exceeded its user defined limit of number of operations	Off
Relay Runtime Alarm	The configured relay has exceeded its user defined limit for time being energized	Off
Temperature Out Of Range	The temperature of the electronics board has exceeded the operating range	Off
Electronic Failure (MCU)	An electronic error has occurred	On
Electronic Failure (IOB)	An electronic error has occurred	On
Keypad Key Stuck	One or more keys are stuck in pressed state	On
Calibration Failure	Calibration of unit is incorrect; field calibration is needed.	On
Device Memory Failure	A device memory error has occurred	On
Startup Failure	Controller repeatedly failed to start up with current configuration settings	On
Software Error	The software in the controller encountered a problem and stopped running	On
Rising Level Alarm	Level is unexpectedly rising while pumps are running	Off
Logger Memory Almost Full	Unused logging memory is below the user defined limit	Off
Logger Memory Full	Logging memory is full	Off
Pump Efficiency Alarm	Pump have loss efficiency	Off
HART Input 1 Output Range HART Input 2 Output Range	Field sensor indicates fault, please consult sensor manual.	Off
Alarm Suppression	Alarm suppression is enabled and the controller is thus not reporting alarms-on-screen, nor on analog outputs or relay outputs	Off

**Related information**

[Configure alarms for fault relay](#)

[Configure alarms for analog output](#)



## B.11 Calculations

### B.11.1 Flow profiles

The Rosemount 3490 Controller can use level measurement to calculate flow in open channel, which can then be totalized. The controller has a library of popular non-linear profiles for flow calculations, and also provides a 20-point programmable look-up table for non-standard applications.

The Low flow cut off feature is useful in an open channel flow application where a small standing or remaining liquid level in the channel would cause continued totalizing of flow when no actual flow exists. The calculated flow can be forced to zero when it falls below a positive threshold, the low flow cut off point.

The pre-defined flow calculation profiles are based on the assumption that flow rate is 0.0 when measured liquid height (level) is 0.0. The sensor input must be configured accordingly in the setup wizard.

#### Parshall

The Rosemount 3490 Controller has a library of data to set-up open channel flow calculations for Parshall flumes.

Select a pre-programmed Parshall flume profile and select desired engineering unit of the calculated flow. Optionally, enter a low-flow cut off point for the calculated flow.

#### Note

Engineering units for Parshall flumes are typically level measurement in feet and flow rate in US gallons per minute (GPM), but the controller will automatically convert measurements values according to actual selected units.

**Table B-31: Parshall Flow Calculation Parameters**

Parameter	Description
Unit	Select desired measurement unit of the calculated flow.
Factor	Select a pre-programmed Parshall flume profile from the drop-down list.
Low flow cut off	Optionally, enter a low-flow cut off point for the calculated flow.

## Vlarem

The Rosemount 3490 Controller has a library of data to set-up open channel flow calculations for Vlarem flat and parabolic flumes.

Select a pre-programmed flat or parabolic flume profile and select desired engineering unit of the calculated flow. Optionally, enter a low-flow cut off point for the calculated flow.

### Note

Engineering units for Vlarem flumes are typically level measurement in meters and flow rate in cubic meters per hour, but the controller will automatically convert measurements values according to actual selected units.

**Table B-32: Vlarem Flow Calculation Parameters**

Parameter	Description
Unit	Select desired measurement unit of the calculated flow.
Factor	Select a pre-programmed flat or parabolic flume profile from the drop-down list.
Low flow cut off	Optionally, enter a low-flow cut off point for the calculated flow.

## Manning

Flow calculations for the Manning profile are based on the Manning formula. Values for the coefficients of the formula are automatically calculated based on the entered settings for maximum flow and height for maximum flow.

Select desired engineering unit for the calculated flow and then enter the maximum flow rate for the weir and the height (level) at which the maximum flow occurs. Optionally, enter a low-flow cut off point for the calculated flow.

**Table B-33: Manning Flow Calculation Parameters**

Parameter	Description
Unit	Select desired measurement unit of the calculated flow.
Max flow	Enter the maximum flow rate for the weir.
Low flow cut off	Optionally, enter a low-flow cut off point for the calculated flow.
Height for max flow	Enter the height (level) at which the maximum flow occurs.

## 20 point look-up flow profile table

The 20-point look-up table can be used to pre-program the controller for custom flow calculation profiles.

Each point in the look-up table is a Cartesian coordinate (X,Y). The X value represents a level, and the Y value is the corresponding flow rate. The X points are user-defined intervals, typically in equal increments of maximum height, and must be entered in increasing order of X values. X values are entered in the selected engineering unit for level measurement, while Y values are entered in the selected engineering unit for flow rate.

**Figure B-14: X: Actual level, Y: Corresponding flow rate**

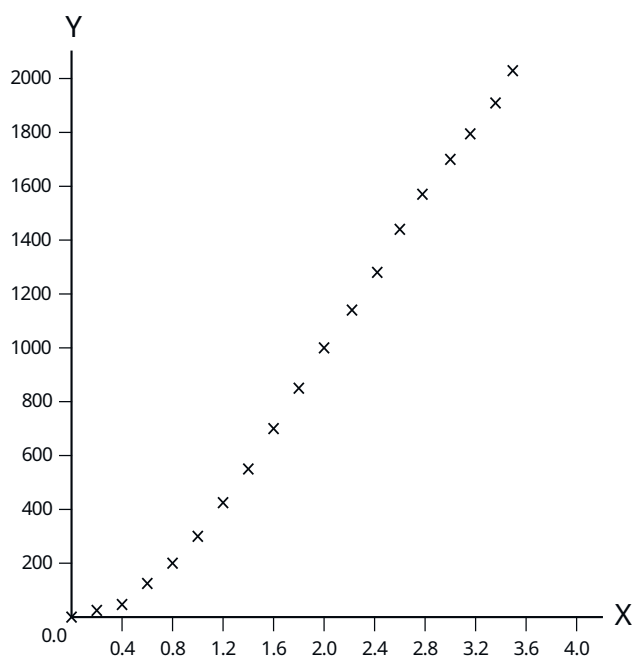

Optionally, enter a low-flow cut off point for the calculated flow.

### Flume/Weir (3/2)

Flow calculations for the Flume 3/2 profile are based on the generic  $Q = K * H^{1.5}$  formula. Values for the coefficients are automatically calculated based on the entered settings for maximum flow and height for maximum flow.

Select desired engineering unit for the calculated flow and then enter the maximum flow rate for the flume and the height (level) at which the maximum flow occurs. Optionally, enter a low-flow cut off point for the calculated flow.

**Table B-34: Flume/Weir (3/2) Flow Calculation Parameters**

Parameter	Description
Unit	Select desired measurement unit of the calculated flow.
Max flow	Enter the maximum flow rate for the flume.
Low flow cut off	Optionally, enter a low-flow cut off point for the calculated flow.
Height for max flow	Enter the height (level) at which the maximum flow occurs.

### V-Notch Weir (5/2)

Flow calculations for the V-Notch 5/2 profile are based on the generic  $Q = K * H^{2.5}$  formula. Values for the coefficients are automatically calculated based on the entered settings for maximum flow and height for maximum flow.

Select desired engineering unit for the calculated flow and then enter the maximum flow rate for the weir and the height (level) at which the maximum flow occurs. Optionally, enter a low-flow cut off point for the calculated flow.

**Table B-35: V-Notch Weir (5/2) Flow Calculation Parameters**

Parameter	Description
Unit	Select desired measurement unit of the calculated flow.
Max flow	Enter the maximum flow rate for the weir.
Low flow cut off	Optionally, enter a low-flow cut off point for the calculated flow.
Height for max flow	Enter the height (level) at which the maximum flow occurs.

### V-Notch Weir (ISO1438)

Flow calculations for a “Kindsvater Shen” V-Notch ISO1438 weir only require the angle of the V-notch to be entered in order to calculate the flow over the weir.

Enter the v-notch angle for the weir and select desired engineering unit of the calculated flow. Optionally, enter a low-flow cut off point for the calculated flow.

#### Note

Engineering units for ISO1438 weirs are typically level measurement in meters and flow rate in cubic meters per second, but the controller will automatically convert measurements values according to actual selected units.

**Table B-36: V-Notch Weir (ISO1438) Flow Calculation Parameters**

Parameter	Description
Unit	Select desired measurement unit of the calculated flow.
Angle	Enter the v-notch angle for the weir.
Low flow cut off	Optionally, enter a low-flow cut off point for the calculated flow.

## B.11.2 Volume profiles

The Rosemount 3490 Controller can use level measurements to calculate the volumetric contents of a linear shaped, closed vessel e.g. a vertical cylinder or rectangular vessel.

The controller can also use level measurements to calculate the volumetric contents of a non-linear shaped, closed vessel. The controller has a library of popular non-linear vessel shapes, for example horizontal cylinder with flat ends, spherical vessel, and horizontal cylinder with domed ends. A 20-point programmable look-up table is provided for non-standard applications.

The calculated volume can be forced to zero when it falls below a positive threshold, the low volume cut off point.

The pre-defined volume calculation profiles are based on the assumption that volume is 0.0 when measured liquid height (level) is 0.0. The sensor input must be configured accordingly in the setup wizard.

## Vertical cylinder

The controller can use level measurements to calculate the volumetric contents of a vertical cylinder.

**Figure B-15: Vertical Cylinder**

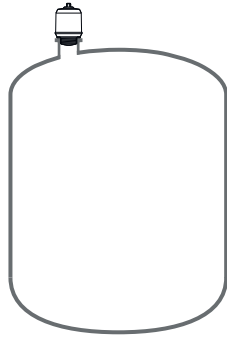

**Table B-37: Vertical Cylinder Volume Calculation Parameters**

Parameter	Description
Unit	Select desired measurement unit of the calculated volume.
Low volume cut off	Optionally, enter a low-volume cut off point for the calculated volume.
Height for max volume	Enter the height (level) at which the maximum volume occurs.

**Table B-38: Vertical Cylinder Volume Method Parameters**

Parameter	Description
Maximum volume	Enter the maximum contents volume of the vessel.
Tank dimensions	Enter the tank diameter.

## Horizontal cylinder flat

The controller can use level measurements to calculate the volumetric contents of a horizontal cylinder with flat ends.

**Figure B-16: Horizontal Cylinder with Flat Ends**

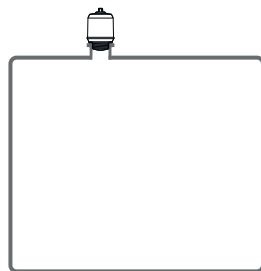

**Table B-39: Horizontal Cylinder Flat Volume Calculation Parameters**

Parameter	Description
Unit	Select desired measurement unit of the calculated volume.
Low volume cut off	Optionally, enter a low-volume cut off point for the calculated volume.
Height for max volume	Enter the height (level) at which the maximum volume occurs.

**Table B-40: Horizontal Cylinder Flat Volume Method Parameters**

Parameter	Description
Maximum volume	Enter the maximum contents volume of the tank.
Tank dimensions	Enter the tank diameter and length.

## Horizontal cylinder domed

The controller can use level measurements to calculate the volumetric contents of a horizontal cylinder with domed ends.

**Figure B-17: Horizontal Cylinder with Domed Ends**

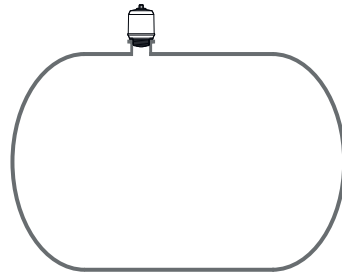

**Table B-41: Horizontal Cylinder Domed Volume Calculation Parameters**

Parameter	Description
Unit	Select desired measurement units
Low volume cut off	Optionally, enter a low-volume cut off point for the calculated volume.
Height for max volume	Enter the height (level) at which the maximum volume occurs.
Maximum volume	Enter the maximum contents volume of the tank.

## Rectangular

The controller can use level measurements to calculate the volumetric contents of a rectangular vessel.

**Figure B-18: Rectangular**

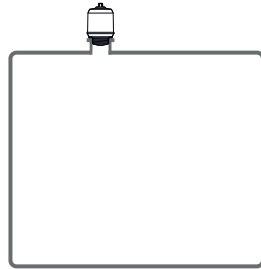

**Table B-42: Rectangular Volume Calculation Parameters**

Parameter	Description
Unit	Select desired measurement unit of the calculated volume.
Low volume cut off	Optionally, enter a low-volume cut off point for the calculated volume.
Height for max volume	Enter the height (level) at which the maximum volume occurs.

**Table B-43: Rectangular Volume Method Parameters**

Parameter	Description
Maximum volume	Enter the maximum contents volume of the vessel.
Tank dimensions	Enter the tank width and length.

## Spherical

The controller can use level measurements to calculate the volumetric contents of a spherical vessel.

**Figure B-19: Spherical**

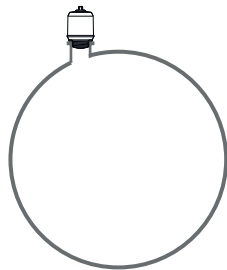

**Table B-44: Spherical Volume Calculation Parameters**

Parameter	Description
Unit	Select desired measurement unit of the calculated volume.
Low volume cut off	Optionally, enter a low-volume cut off point for the calculated volume.
Height for max volume	Enter the height (level) at which the maximum volume occurs.
Maximum tank volume	Enter the maximum contents volume of the tank.

## Conical bottom

The controller can use level measurements to calculate the volumetric contents of a vessel with conical bottom.

**Figure B-20: Conical bottom**



**Table B-45: Conical Bottom Volume Calculation Parameters**

Parameter	Description
Unit	Select desired measurement unit of the calculated volume.
Low volume cut off	Optionally, enter a low-volume cut off point for the calculated volume.
Height for max volume	Enter the height (level) at which the maximum volume occurs.
Maximum tank volume	Enter the maximum contents volume of the tank.

## 20 point look-up volume profile table

The 20-point look-up table can be used to pre-program the controller for custom volume calculation profiles.

Each point in the look-up table is a Cartesian coordinate (X,Y). The X value represents a level, and the Y value is the corresponding volume. The X points are user-defined intervals, typically in equal increments of maximum height, and must be entered in increasing order of X values. X values are entered in the selected engineering unit for level measurement, while Y values are entered in the selected engineering unit for volume.



Figure B-21: X: Actual level, Y: Corresponding volume

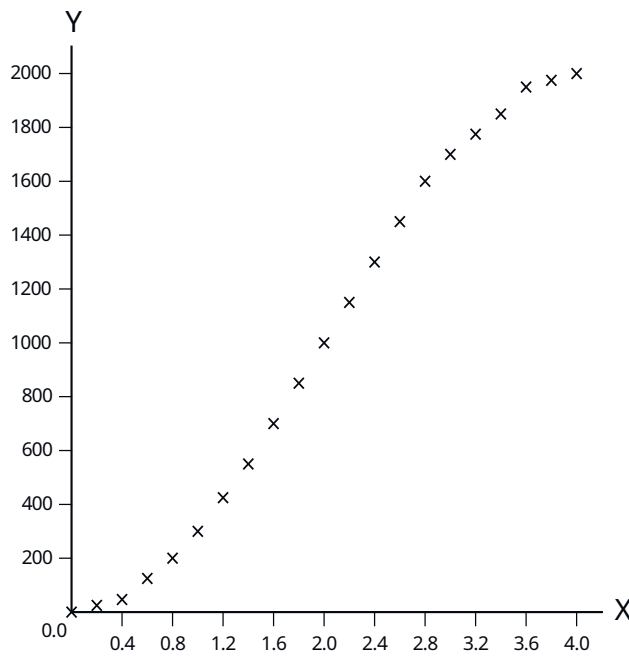

Optionally, enter a low-flow cut off point for the calculated volume.

### B.11.3 Totalizer configuration

The purpose of a totalizer is to accumulate for example the amount of liquid that has passed through a ditch. When the calculated value is a volumetric flow rate (e.g. m<sup>3</sup>/hour), the totalizer can accumulate this flow volume and give the total volume throughput. A new totalizer value is calculated every second.

The controller provides two internal 8-digit totalizers: Totalizer 1 (accumulated) and Totalizer 2 (daily). Totalizer 2 provides the daily flow total for the present day. It is reset to zero at midnight.

The totalizer function can be easily setup using the Open Channel Flow Wizard, as shown in Figure B-22.

Figure B-22: Totalizer Configuration in the Open Channel Flow Wizard

**Totalizer configuration** NEXT

Use totalizer? Totalizer 1 Unit (Tot1) Accumulated

Yes m<sup>3</sup> x 1

No Totalizer 2 Unit (Tot2) Daily total

Totalizer 1 Relay (relay 1) m<sup>3</sup> x 100

Totalizer 2 Relay

A totalizer relay can output a pulse for each time that the internal totalizer count increments. The totalizer relay mode is used to set the selected relay to either Totalizer 1 (accumulating) or Totalizer 2 (daily).

For some units, the totalizer increments rapidly and rolls over too frequently. To help, alternative totalizer units are available for selection, see [Table B-46](#). When these special units are selected the totalizer factor is automatically rescaled by x10, x100, x1000, or x1000000 depending on the selection.

**Table B-46: Totalizer Unit Settings**

Value	Description
Unit x 1	Select desired measurement units.
Unit x 10	Select desired measurement units, the totalizer factor is rescaled by x10.
Unit x 100	Select desired measurement units, the totalizer factor is rescaled by x100.
Unit x 1000	Select desired measurement units, the totalizer factor is rescaled by x1000.
Unit x million	Select desired measurement units, the totalizer factor is rescaled by x1000000.

The two totalizers are displayed on the main screen, as shown in [Figure B-23](#).

**Figure B-23: Totalizer Values Presented on Main Screen**

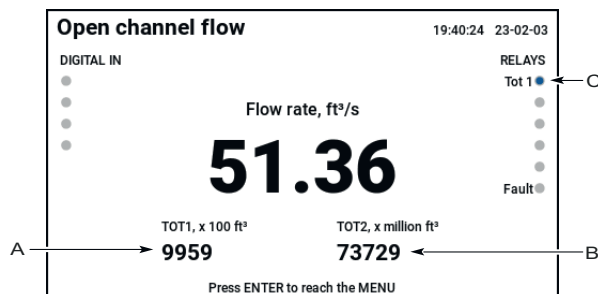

- A. Totalizer 1 (accumulated) value
- B. Totalizer 2 (daily) value
- C. Relay mode set to Totalizer 1

**Related information**

- [Example: Set up an open channel flow application](#)
- [Totalizer relay output](#)
- [Totalizer relay mode](#)
- [Reset totalizer](#)

## B.12 Data logging

The data logging function handles logging of totalizer and parameter values. The controller can log up to 200 000 events at regular intervals. Logged data may be downloaded any time using the web interface.

The totalizers data is logged on daily basis, if at least one of the totalizers are in use. This is done just before reset of the daily totalizer is performed.

The parameters to be logged are the ones that are configured to be shown on the main screen; middle, left and right field content values together with current units. The parameters are saved based on user defined interval settings.

Data logging is setup using the Setup/Logger from the Service menu. The data logging function is automatically activated for open channel flow applications configured by the setup wizard.

**Figure B-24: Data Logger Settings in the Service Menu**

The screenshot shows the 'Setup / Logger' configuration screen. It contains the following settings:

- Logger interval: 1 min
- Bad data trigger: DIN 1
- Logging mode: Continuous
- Alarm level (free space): 002.0%
- Alarm relay: Yes

A 'FINISH' button with a checkmark is located in the top right corner of the screen.

**Table B-47: Data Logging Settings**

Parameter	Description
Logger interval	The data logger function is by default inactive (Logger interval default value: off). To activate the logger set the Logger interval to a value in the range 1 to 60 minutes. This interval defines at what rate the parameters shall be saved.
Bad data trigger	A digital input can be setup to indicate a bad data in the logger when activated. If the digital input has been active during the logger interval, the logged data is flagged as a 'bad sample'.
Logging mode	The Logging mode is used to select action when the logger memory is full. If the Logging mode is set to Continuous, data logging will continue and overwrite the oldest data when the logger memory is full. If the Logging mode is set to Stop when full, data logging will stop when the logger memory is full. If Logging mode is set to Continuous, the Logger Memory Full alarm will be inactive.
Alarm level (free space)	An alarm can be activated to indicate when the unused memory falls to below a user-defined percentage. The Alarm level (free space) is used to specify the limit of free space for the logger memory where the alarm condition Logger Memory Almost Full shall be activated.
Alarm relay	If the Alarm relay is set to Yes, the alarms Logger Memory Almost Full and Logger Memory Full are setup to be indicated by the fault relay when triggered.

**Related information**

[Setup logger](#)

[Example: Set up an open channel flow application](#)

[Download log file to a PC](#)

## B.12.1 Log files

Log files are stored in plain text file format (.csv) and can be viewed in any word processing program, customized for Microsoft® Excel® import.

**Figure B-25: Totalizer Log File Example**

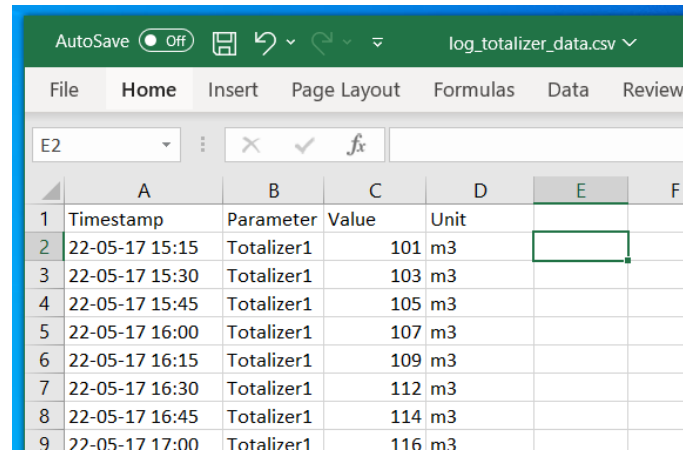

	A	B	C	D	E	F
1	Timestamp	Parameter	Value	Unit		
2	22-05-17 15:15	Totalizer1	101	m3		
3	22-05-17 15:30	Totalizer1	103	m3		
4	22-05-17 15:45	Totalizer1	105	m3		
5	22-05-17 16:00	Totalizer1	107	m3		
6	22-05-17 16:15	Totalizer1	109	m3		
7	22-05-17 16:30	Totalizer1	112	m3		
8	22-05-17 16:45	Totalizer1	114	m3		
9	22-05-17 17:00	Totalizer1	116	m3		

# C Modbus® register table

## C.1 Introduction

The Rosemount 3490 Controller stores measurement data, calculated values, and status information in Modbus® input registers.

The input registers can be scanned in queries from a Modbus master using Modbus TCP/IP communication, connected to port 502. The controller responds on all Modbus addresses; 1-255. This appendix lists the available input registers.

### Related information

[Set device IP address](#)

## C.2 FC04 register area

This section presents the predefined register area for each application. Read the register area for your configured application to get sufficient data.

### C.2.1 Register area: Level and pump control

**Table C-1: Register Area: Level and Pump Control**

Register Number	Register Name	Type	Unit	Description
20000	Level	FLOAT		Level (Sensor input 1) Unit is specified in Level Unit Register Area below, see register 20006.
20002	Level, Rate of Change	FLOAT		Rate of change
20004	Level Status	BITFIELD		Level calculation status Bit 0: Invalid Bit 1: Frozen Bit 2: Locked by din
20006	Level Unit	ENUM		Level unit 44: Feet 45: Meter 47: Inch 48: Centimeter 49: Millimeter 57: Percent 251: None
20008	Relay Output Status	BITFIELD		Relay status Bit 0: Relay 1 Energized Bit 1: Relay 2 Energized Bit 2: Relay 3 Energized Bit 3: Relay 4 Energized Bit 4: Relay 5 Energized Bit 5: Relay 6 Energized

**Table C-1: Register Area: Level and Pump Control (continued)**

Register Number	Register Name	Type	Unit	Description
20010	Digital Input Status	BITFIELD		Digital input status Bit 0: Digital input 1 Active Bit 1: Digital input 2 Active Bit 2: Digital input 3 Active Bit 3: Digital input 4 Active

## C.2.2 Register area: Open channel flow

**Table C-2: Register Area: Open channel flow**

Register Number	Register Name	Type	Unit	Description
23000	Flow	FLOAT		Flow (Sensor input 1) Unit is specified in Flow Unit Register Area below, see register 23006.
23002	Flow, Rate of Change	FLOAT		Flow rate of change
23004	Flow Status	BITFIELD		Flow calculation status Bit 0: Invalid Bit 1: Frozen Bit 2: Locked by din
23006	Flow Unit	ENUM		Flow unit 15: Cubic Feet Per Minute 16: US Gallon Per Minute 17: Liters Per Minute 18: UK Gallon Per Minute 19: Cubic Meter Per Hour 20: Feet Per Second 21: Meter Per Second 23: Megagallon Per Day 24: Liter Per Second 26: Cubic Feet Per Second 27: Cubic Feet Per Day 28: Cubic Meter Per Second 30: UK Gallon Per Hour 31: UK Gallon Per Day 120: Meter Per Hour 130: Cubic Feet Per Hour 134: Barrel Per Hour 136: US Gallon Per Hour 138: Liters Per Hour 235: US Gallon Per Day 247: Feet Per Hour 251: None

**Table C-2: Register Area: Open channel flow (continued)**

Register Number	Register Name	Type	Unit	Description
23008	Relay Output Status	BITFIELD		Relay status Bit 0: Relay 1 Energized Bit 1: Relay 2 Energized Bit 2: Relay 3 Energized Bit 3: Relay 4 Energized Bit 4: Relay 5 Energized Bit 5: Relay 6 Energized
23010	Digital Input Status	BITFIELD		Digital input status Bit 0: Digital input 1 Active Bit 1: Digital input 2 Active Bit 2: Digital input 3 Active Bit 3: Digital input 4 Active
23012	Totalizer 1	DWORD		Current Totalizer 1 value
23014	Totalizer 1 Factor	ENUM	1, 10, 100, 1000, Million	Totalizer 1 factor 0: None 1: Times1 2: Times10 3: Times100 4: Times1000 5: Times Million
	Totalizer 2	DWORD		Current Totalizer 2 value
	Totalizer 2 Factor	ENUM	1, 10, 100, 1000, Million	Totalizer 2 factor 0: None 1: Times1 2: Times10 3: Times100 4: Times1000 5: Times Million

### C.2.3 Register area: Differential level

**Table C-3: Register Area: Differential level**

Register Number	Register Name	Type	Unit	Description
21000	Diff Level	FLOAT		Diff level value Unit is specified in Level Unit Register Area below, see register 21018.
21002	Diff Level, Rate of Change	FLOAT		Diff level rate of change
21004	Diff Level Status	BITFIELD		Diff level calculation status Bit 0: Invalid Bit 1: Frozen Bit 2: Locked by din

**Table C-3: Register Area: Differential level (continued)**

Register Number	Register Name	Type	Unit	Description
21006	Level 1	FLOAT		Level 1 value Unit is specified in Level Unit Register Area below, see register 21018.
21008	Level 1, Rate of change	FLOAT		Level 1 rate of change
21010	Level 1 Status	BITFIELD		Level 1 calculation status Bit 0: Invalid Bit 1: Frozen Bit 2: Locked by din
21012	Level 2	FLOAT		Level 2 value Unit is specified in Level Unit Register Area below, see register 21018.
21014	Level 2, Rate of change	FLOAT		Level 2 rate of change
21016	Level 2 Status	BITFIELD		Level 2 calculation status Bit 0: Invalid Bit 1: Frozen Bit 2: Locked by din
21018	Level Unit	ENUM		Level unit 44: Feet 45: Meter 47: Inch 48: Centimeter 49: Millimeter 57: Percent 251: None
21020	Relay Output Status	BITFIELD		Relay status Bit 0: Relay 1 Energized Bit 1: Relay 2 Energized Bit 2: Relay 3 Energized Bit 3: Relay 4 Energized Bit 4: Relay 5 Energized Bit 5: Relay 6 Energized
21022	Digital Input Status	BITFIELD		Digital input status Bit 0: Digital input 1 Active Bit 1: Digital input 2 Active Bit 2: Digital input 3 Active Bit 3: Digital input 4 Active



## C.2.4 Register area: Tank volume

Table C-4: Register Area: Tank volume

Register Number	Register Name	Type	Unit	Description
22000	Volume	FLOAT		Volume (Sensor input 1)  Unit is specified in Volume Unit Register Area below, see register 22006.
22002	Volumel, Rate of Change	FLOAT		Volume rate of change
22004	Volume Status	BITFIELD		Volume calculation status Bit 0: Invalid Bit 1: Frozen Bit 2: Locked by din
22006	Volume Unit	ENUM		Volume unit 40: US Gallon 41: Liter 42: UK Gallon 43: Cubic meter 46: Barrel 112: Cubic Feet 173: Megagallon 251: None
22008	Relay Output Status	BITFIELD		Relay status Bit 0: Relay 1 Energized Bit 1: Relay 2 Energized Bit 2: Relay 3 Energized Bit 3: Relay 4 Energized Bit 4: Relay 5 Energized Bit 5: Relay 6 Energized
22010	Digital Input Status	BITFIELD		Digital input status Bit 0: Digital input 1 Active Bit 1: Digital input 2 Active Bit 2: Digital input 3 Active Bit 3: Digital input 4 Active

For more information: [Emerson.com/global](https://emerson.com/global)

©2024 Emerson. All rights reserved.

Emerson Terms and Conditions of Sale are available upon request. The Emerson logo is a trademark and service mark of Emerson Electric Co. Rosemount is a mark of one of the Emerson family of companies. All other marks are the property of their respective owners.

**ROSEMOUNT™**

