

# M-VF

Safety Excess Flow Valve for Corrosive and Non-corrosive Fluids

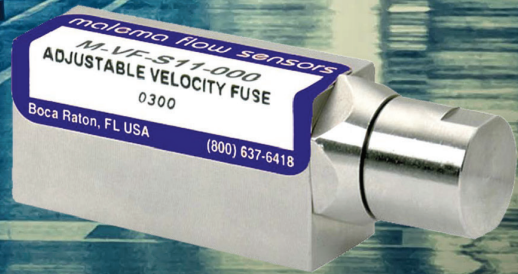

Where Innovation Flows



The stainless steel M-VF Series Safety Excess Flow Valves are engineered for fast automatic shut-off in case of line, hose or fitting failures, protecting employees, plant, and valuable instruments. The M-VF comes in five port sizes – 1/8", 1/4", 3/8", 1/2" and 3/4" sizes, and the option to chose a FKM or FFKM o-ring for optimal chemical compatibility. Designed for protection of systems handling corrosive, toxic, radioactive and flammable materials; the valve will instantly detect surge in the system and stop fluid flow. When the line break is repaired and pressure is equalized in the system, the valve will open to allow the fluid to flow through the system. The M-VF operates effectively with all fluids, liquids or gases.

## Operation

As the fluid (liquid or gas) enters the valve, the Pressure differential across the piston creates a venturi effect, accelerating the flow through the valve. At a preset flow rate, when the differential exceeds the magnetic attraction between the piston magnet and the adjusting screw magnet, the piston travels instantaneously over towards the output port, thereby shutting off the flow. When the pressure is equalized between both sides of the valve, the piston automatically returns to its previous adjusted flow setpoint. The shut off point is field adjustable and this is achieved by turning the adjusting screw.

## Applications

- Pollution control
- Compressed air and gas system
- Leak detection
- Gas analysers
- Hydraulic lines
- Sampling station operator protection
- Regulator protection
- Catastrophic failure protection

## Key Features

- High reliability
- Field adjustable
- Low pressure drop
- All mechanical
- Right angle flow

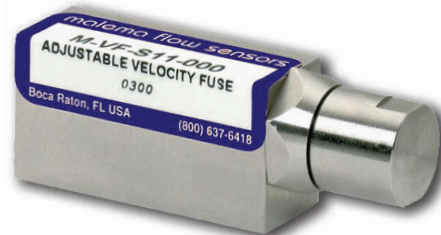
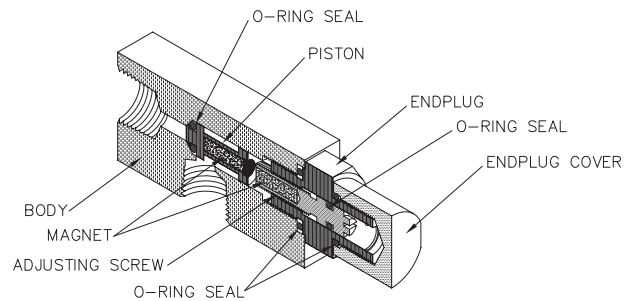

## Specifications

Set Point Accuracy	± 10% maximum
Repeatability	3%
Port Sizes	<ul style="list-style-type: none"> <li>• 1/8" • 1/4" • 3/8"</li> <li>• 1/2" • 3/4"</li> </ul>

## Material Versions

Housing, End Plug and Adjusting Screw	316SS
Magnet in Adjusting Screw & Pistons	Alnico
Piston	316SS
O-rings	<ul style="list-style-type: none"> <li>• FKM</li> <li>• FFKM</li> </ul>
Pressure and Temperature Specifications Maximum Operating (psig)** Burst (psig) Maximum Operating Temperature***	3,500 5,000 149°C (300°F)

## Flow Range Table

Port Size (FNPT)	M-VF adjustable range for water at 70°F	M-VF adjustable range for Air at 14.7 PSIA and 70°F
	Min-Max (ccm)	Min-Max (sccm)
1/8"	5 - 1,200	100 - 50,000
1/4"	40 - 6,000	1,000 - 200,000
3/8"	100 - 7,000	1,500 - 250,000
1/2"	200 - 14,000	2,000 - 500,000
3/4"	500 - 25,000	10,000 - 900,000

## Installation and Flow Rate Adjustment

1. The preferred mounting orientation for the valve is in the horizontal position, although it can be mounted vertically.
2. Turn the adjusting screw fully counter-clockwise.
3. Connect hose or piping to outlet and operate at maximum flow rate (liquid or gas).
4. Turn the adjusting screw clockwise until the valve actuates and shuts off flow.
5. Turn the flow off. The valve will automatically reset because of its controlled bleed. For positive shut-off models, equalize the pressure on both sides of the valve. The valve will reset as the pressure is equalized and automatically return to its previously adjusted flow setting.
6. Turn the adjusting screw (one turn) counter-clockwise and system is ready to function.

Note: In high pressure environments, step 4 may need to be done iteratively under no flow conditions, after which flow can be resumed to test for valve actuation.

## Maintenance

It is beneficial to have adequate filtration in the system prior to the valve as otherwise, its functioning may be hampered by large particles interfering with the travel of the piston. Using an adjustable wrench, gently remove the end-plug from the valve body. Examine the piston, the O-rings, and the surfaces of the valve bore and clean with trichloroethane if necessary, prior to reassembling (Replacement parts are available on request). Adequate sealing methods must be used at all connections to the valve to prevent leakage.

# Dimensional Drawings

Illustrated is the M-VF model with 1/8" ports

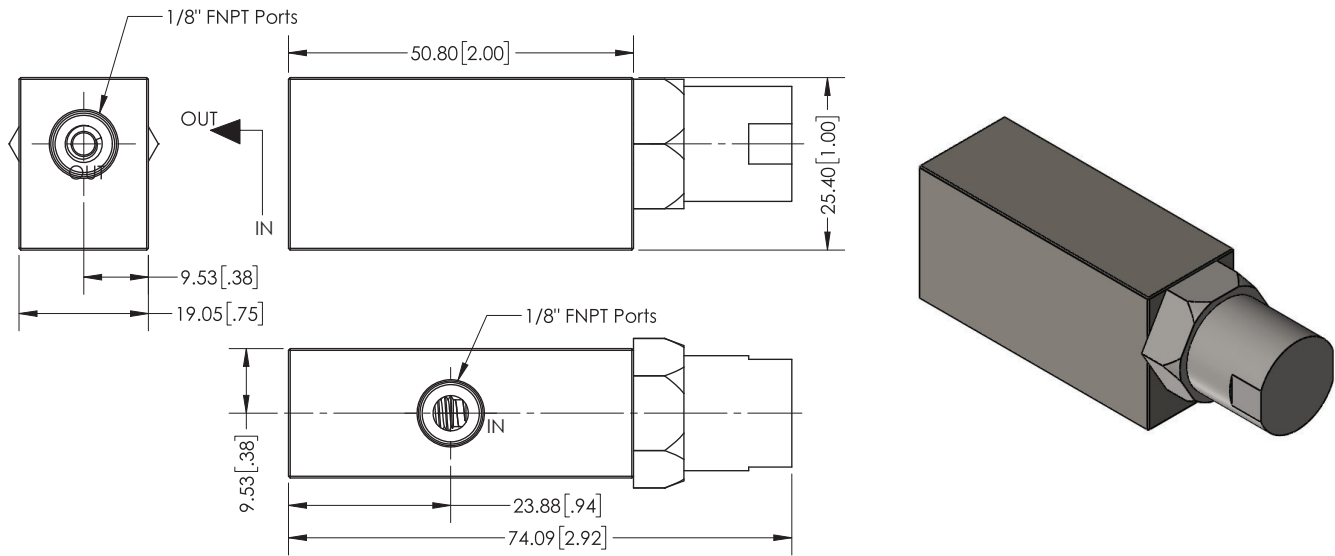

Illustrated is the M-VF model with 1/4" ports

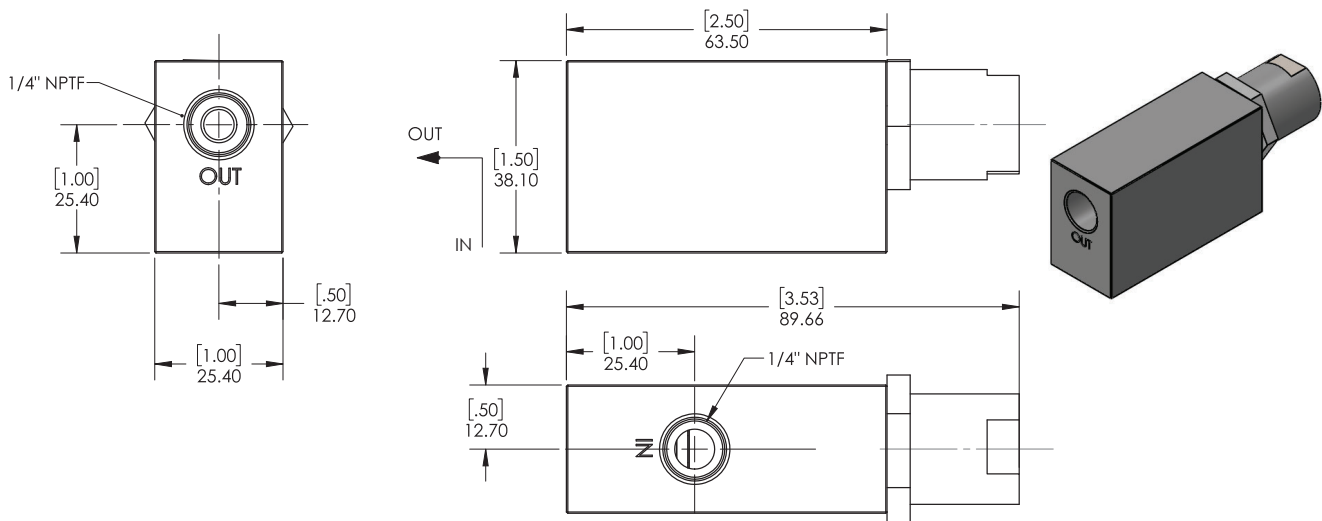

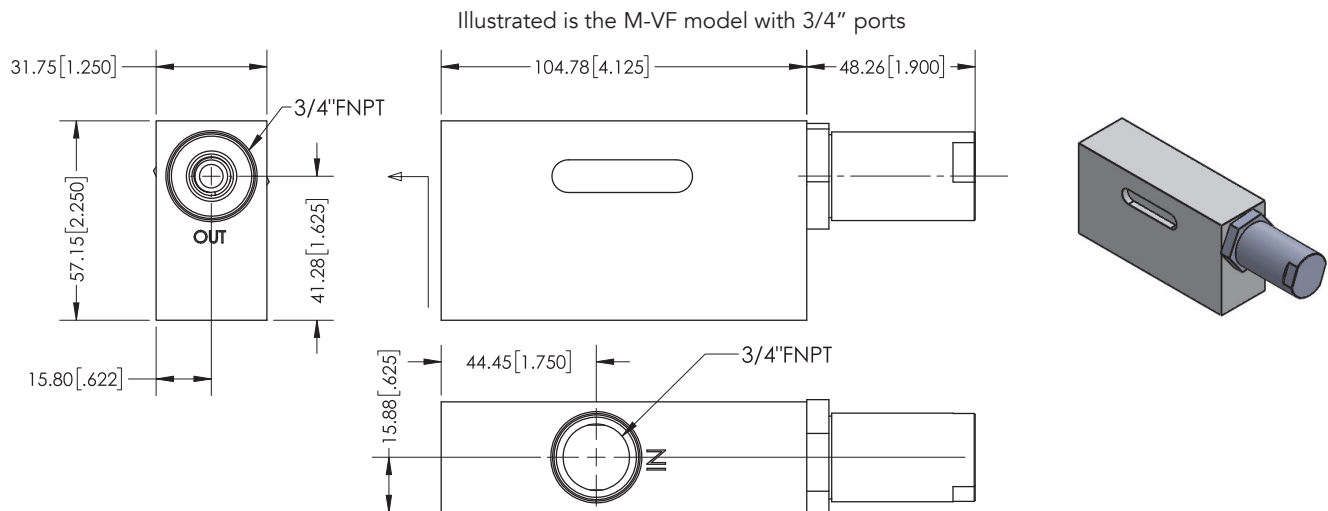
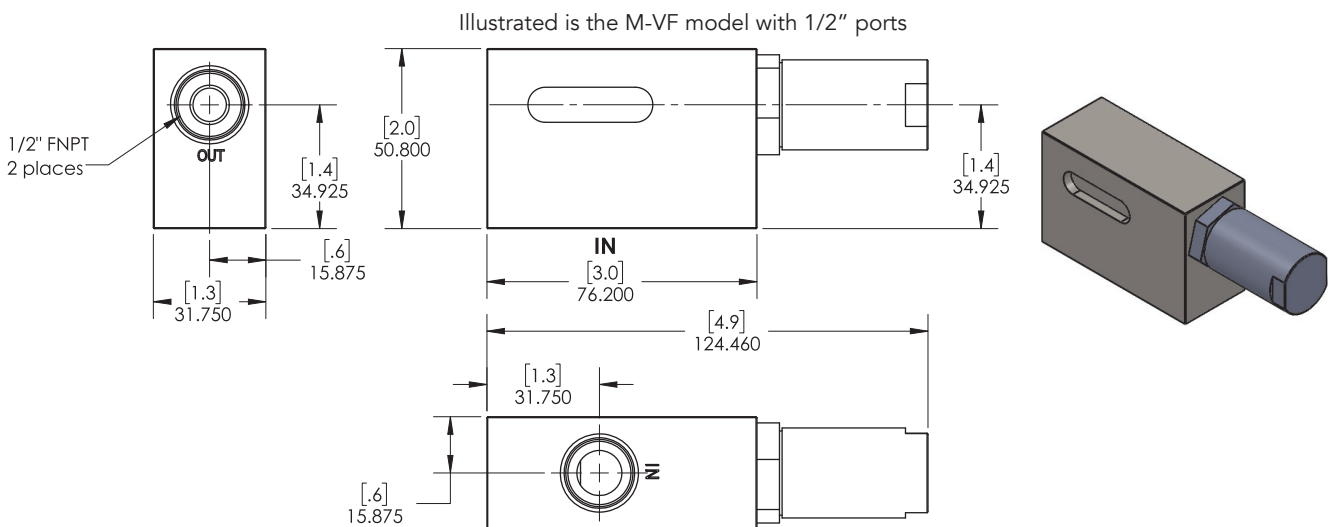
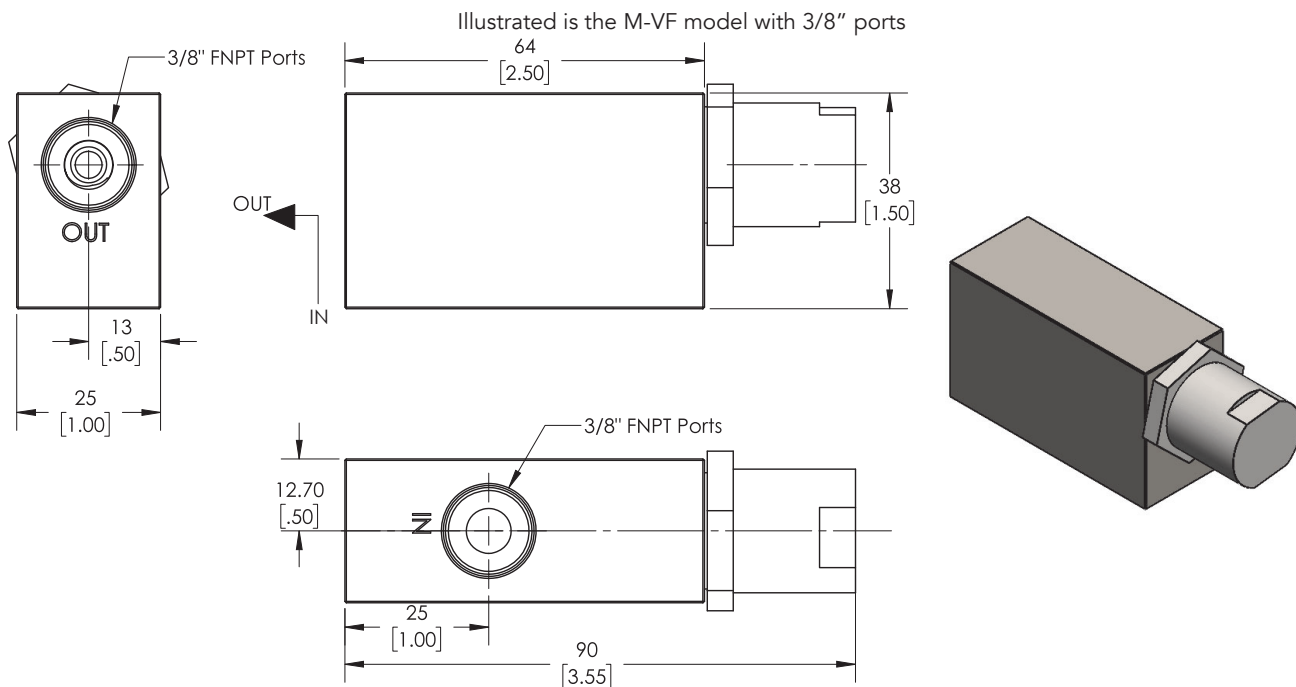

## Ordering Information

Standard Part Numbers					
Model	Port Size	M-VF adjustable range for water at 70°F	M-VF adjustable range for Air at 14.7 psia and 70°F	Part number	
				M-VF with FKM O-ring seal	M-VF with FFKM O-ring seal
M-VF	1/8" FNPT	5 - 1,200 ccm	100 - 50,000 sccm	M-VF-S11-010-S001	M-VF-S11-011-S001
	1/4" FNPT	40 - 6,000 ccm	1,000 - 200,000 sccm	M-VF-S21-010-S001	M-VF-S21-011-S001
	3/8" FNPT	100 - 7,000 ccm	1,500 - 250,000 sccm	M-VF-S31-010-S001	M-VF-S31-011-S001
	1/2" FNPT	200 - 14,000 ccm	2,000 - 500,000 sccm	M-VF-S41-010-S001	M-VF-S41-011-S001
	3/4" FNPT	500 - 25,000 ccm	10,000 - 900,000 sccm	M-VF-S61-010-S001	M-VF-S61-011-S001

- Note:**
- Material compatibility choices are solely the responsibility of the end user.
  - Specifications are subject to change without notice.
  - Selection and use of the excess flow valve for the fluids and conditions other than listed above is solely the responsibility of the end user.
  - For M-VF with a custom factory-set shut-off flow rate for liquid or gas flow applications, please contact the factory with the application information as needed in the Malema Excess Flow Valve application questionnaire.



PSG  
Malema  
1060 S Rogers Circle  
Boca Raton, FL 33487  
USA  
P: +1 (800) 637-6418  
[psgdover.com/malema](http://psgdover.com/malema)



Where Innovation Flows

INSTMRT-DS-MVF-32027071

Authorized PSG® Partner:

Copyright 2023 PSG®, a Dover company