

M-60X

Explosion Proof Flow Switch with Fixed Set Point and In-Line Flow



Where Innovation Flows



The M-60X Explosion Proof Series Flow Switches monitor increasing and decreasing flow. With the ability to monitor low flow ranges from 750 to 1,600 cc/min for water and 25,000 to 55,000 scc/min for air. They utilize a single moving part which responds to fluid (liquid or gas) flowing within a system. These extremely sensitive explosion-proof flow switches are engineered to monitor vital sample flow parameters for instrumentation in process control and inert blanket gases. When triggered, the fixed set point models will be within 10% of the desired set point, while all models offer repeatability of 5%. These switches are suitable for a wide range of applications in industrial, biomedical and OEM products. The flow monitors operate only when fluid flows is absolutely established.

Custom set point calibration of the M-60X Flow Switches can be programed at our Malema facility before shipping. Additionally, the M-60X Explosion Proof Flow Switches have the option of standard pre-calibrated set point ranges for immediate use and distribution. These switches come in SPDT configurations and are UL listed, ATEX and IECEx certified.

Operating Principle

The operating principle is based on a free floating magnetic piston which responds only to the motion of fluids within the line, not to static or system pressures. In the presence of fluid flow, controlled movement of the piston actuates an external hermetically sealed reed switch thus opening or closing the required signal circuit. This signal can be used to actuate audible or visual alarms as well as relays, or other controls. Piston travel is short which insures low hysteresis. Pressure drop across flowswitch varies from 0.035 to 2 psi (at maximum flowrates for air and liquid). Universal mounted units are outfitted with a spring which resets the piston. The spring is held in place using a perforated disc.

Applications

- Gas panels
- Hazardous fluid systems
- Pollution control monitors
- Gas leak monitors
- Sample flow monitoring
- Purge flows

Key Features

- Well suitable for corrosive and non-corrosive liquids or gases
- UL recognized for hazardous location
- ATEX certified for intrinsic safety and encapsulation and dust environments
- Community Europe compliant
- Universal mounting available



Material Versions

Housing	316 SS
Pistons	316 SS
Orifice Plate or disc (Only in Universal Mounting Version)	316 SS
Spring	Stainless Steel
Retaining ring	Stainless Steel

Calibration range

Air	25,000 - 55,000 scc/min
Water	750 - 1,600 cc/min

For lower and higher trip points contact factory. Maximum flow through switch are higher.

Specifications

Set Point Accuracy	± 10% maximum
Hysteresis	15% - 30%
Repeatability	± 2%

Port size

1/4" FNPT

Standard Specifications

Maximum Operating (psig)	3,000
Burst (psig)	5,000
Maximum Operating temperature	175°C (347°F)

Electrical Specifications

Reed Switch data (Electical Ratings)	10 Watts SPST or 3 Watts SPDT (Hermetically Sealed) UL Recognized. File E47258
Operating temperature	-40°C to 175°C
Switch voltage	200 Vdc (170 Vdc for SPDT)
Breakdown voltage	250 Vdc (200 Vdc for SPDT)
DC Resistive	10 VA (3 VA for SPDT)
AC Resistive	10 Watts (3 Watts for SPDT)
Switching current	0.5 A (0.25 A for SPDT)
Carrying current	1.2 A (0.5 A for SPDT)
Lead Wires	No 24 to 18 AWG. 18" length, Polymeric UL Recognized (Belden cable or special shielded cable is available)
Lead Wires Color	SPDT: Green - Common, Yellow - Normally Closed, Orange - Normally Open

Reed Switch Ratings as Recognized by UL

SPDT	120 Vac 10 Vdc 24 Vdc	0.1 A general purpose 0.25 A resistive 0.1 A resistive
------	-----------------------------	--

Fixed Flow Setting Information

This model is a FIXED flow switch. The flow set point is fixed at the factory and is NOT field adjustable. Proper calibration of the set point requires additional information. Typical application details required before purchasing the product are:



- Calibration set point
- Increasing or decreasing flow
- Fluid type (i.e. liquid or gas)
- Density or specific gravity
- Viscosity
- System pressure and temperature
- Flow direction (i.e. upward or downward)
- Mounting orientation (i.e. horizontal or vertical)



Installation and Maintenance

The standard switch has to be mounted vertically in the position shown above for normally open conditions and inverted position for normally closed conditions. When inverted, the switch set point will change by $\pm 5\%$; please use the product in the orientation it was calibrated (as indicated by reading the label). Universal units can be mounted horizontally or vertically. Please advise mounting orientation while ordering, so that the factory can calibrate in the required orientation as calibration does change slightly when changing orientation. Adequate filtration and sealing procedures should be used when mounting in flow lines. For detailed directions, please refer to our manual.





Certifications

- UL and Canadian UL Recognized for use in USR, CNR - Class I, Groups A, B, C and D; Class II, Groups E, F and G, all divisions (applicable to M-100X, M-50X and M-60X), under UL File # E153446
- UL and Canadian UL Recognized for use in USR, CNR - Class I, Groups C and D; Class II, Groups E, F and G, all divisions – (applicable to M-200X), under UL File # E153446
- ATEX Certification for Intrinsic Safety and Encapsulation (under DEMKO 19 ATEX 2278X and DEMKO 19 ATEX 2270X) (Refer to control drawing for additional details)

 II 1 G Ex ia IIC T6...T3 Ga
 II 1 D Ex ia IIIC T80°C ... T150°C Da

 II 2 G Ex mb IIC T3 Gb
 II 2 D Ex mb IIIC T150°C Db

- IECEx Certification for Encapsulation and Intrinsic Safety (under IECEx UL 13.0067X and IECEx UL 13.0065X) (Refer to control drawing for additional details)

 ia IIC T6...T3
 ia III C T80...T150°C Da
 mb IIC T3 Gb
 mb IIIC T150°C Db (-40°C to +145°C)

Electrical parameters
Um = 250 V and Im = 1 A

Electrical parameters
Ui ≤ 30 V
Pi ≤ 0,7 W
Ci = 40pf
Li = 4 μH

Ambient temperature range	Temperature class for Gas	Temperature class for Dust
- 40°C to 60°C	T6	T95°C
- 40°C to 75°C	T5	T95°C
- 40°C to 117°C	T3	T140°C
- 40°C to 149°C	T3	T175°C

- **CE Mark:** All EX flow switches are CE certified per ATEX Directive 2014/34/EU

Cut Dimensional Drawings

Illustrated is the M-60X model with 1/4" ports and SPDT switch.

For Reference Only

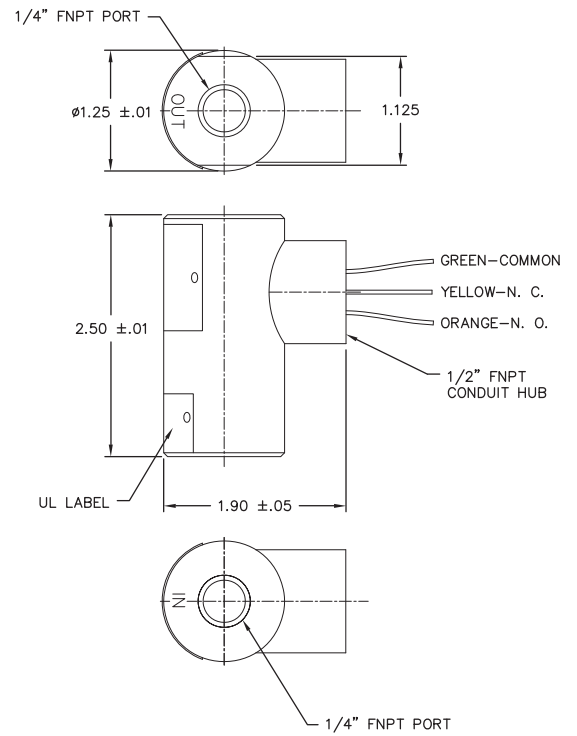
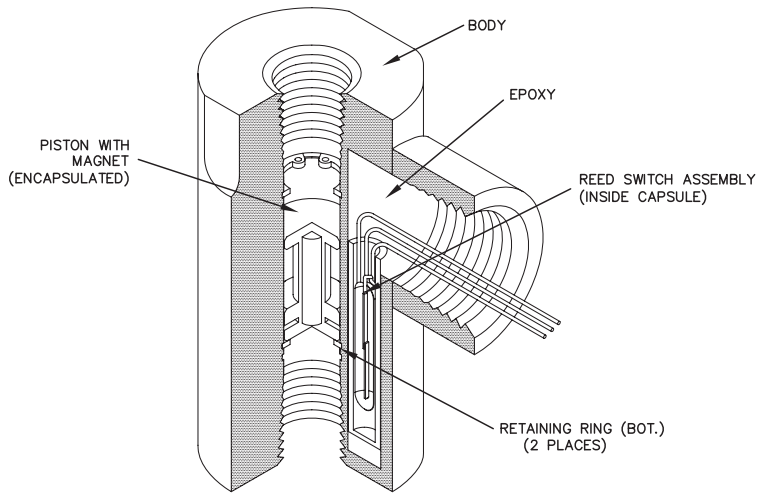

Ordering Information

Model Ordering Code										Option
M-60X	-	*	*	*	-	*	*	-	***	
	-									
Material	S									316SS
Port		2								1/4"
Switch			3							SPDT
					-					
Mounting					0					Standard (Vertical)
					1					Universal Mounting (with Disc and Spring)
Piston					0					316SS with Epoxy
					1					PTFE Encapsulated
					2					All-316SS (No Epoxy)
								-	XXX	Unique PN Identifier



PSG
Malema
1060 S Rogers Circle
Boca Raton, FL 33487
USA
P: +1 (800) 637-6418
psgdover.com/malema



Where Innovation Flows

DS-M60X-32028010

Authorized PSG® Partner:

Copyright 2023 PSG®, a Dover company