



OPTIFLUX 5000 **Technical Datasheet**

Electromagnetic flowmeter in flanged version

- Exceptional long-term stability and accuracy
- For highly aggressive and abrasive fluids
- Fully vacuum-resistant with high-tech ceramics liner



The documentation is only complete when used in combination with the relevant documentation for the signal converter.

1	Product features	3
<hr/>		
1.1	Solution with high-tech ceramics	3
1.2	Options and variants	5
1.3	Measuring principle.....	6
2	Technical data	7
<hr/>		
2.1	Technical data.....	7
2.2	Dimensions and weights	11
2.3	Measuring accuracy	14
3	Installation	15
<hr/>		
3.1	Notes on installation	15
3.2	Intended use	15
3.3	Installation conditions	15
3.3.1	Inlet and outlet	15
3.3.2	Mounting position.....	15
3.3.3	Flange deviation.....	16
3.3.4	T-section	16
3.3.5	Vibration	16
3.3.6	Magnetic field.....	17
3.3.7	Bends	17
3.3.8	Open discharge	18
3.3.9	Control valve	18
3.3.10	Air venting	18
3.3.11	Pump	19
4	Electrical connections	20
<hr/>		
4.1	Safety instructions.....	20
4.2	Grounding	20
4.3	Virtual reference for IFC 300 (C, W and F version)	21
5	Notes	22
<hr/>		

1.1 Solution with high-tech ceramics

The **OPTIFLUX 5000** is one of the most accurate flowmeters available in the market today. This is the result of a special tube design with conical parts, optimizing the flow profile. Leading metrological institutes use the **OPTIFLUX 5000** as their master meter.



- ① Flanged design
- ② Ceramic liner
- ③ Cermet electrodes

Highlights

- Exceptional long-term stability and accuracy
- Unique flow tube
- Fused in-place Cermet or platinum electrodes
- For highly aggressive and abrasive fluids
- Fully vacuum-resistant
- High-tech ceramics liner
- Insensitive against temperature shocks

Industries

- Chemical
- Paper & pulp
- Water & wastewater
- Minerals & mining
- Food & beverage
- Machinery

Applications

- Master transfer meter
- Precise volumetric dosing of additives
- Chemical injection
- For acids, alkaline, paste, slurries and many other aggressive media even with high solid contents

1.2 Options and variants



- Nominal diameter range DN15...300
- Several pressure ratings
- Configurable with IFC 100 and IFC 300 converter
- Hazardous areas
- Groundings rings available in high grade alloy's
- Virtual reference
- Stainless steel versions

1.3 Measuring principle

An electrically conductive fluid flows inside an electrically insulated pipe through a magnetic field. This magnetic field is generated by a current, flowing through a pair of field coils. Inside of the fluid, a voltage U is generated:

$$U = v * k * B * D$$

in which:

v = mean flow velocity

k = factor correcting for geometry

B = magnetic field strength

D = inner diameter of flow meter

The signal voltage U is picked off by electrodes and is proportional to the mean flow velocity v and thus the flow rate q . A signal converter is used to amplify the signal voltage, filter it and convert it into signals for totalising, recording and output processing.

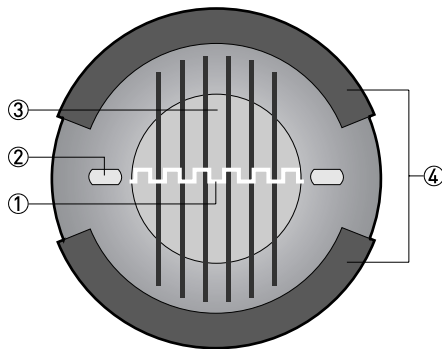

- ① Induced voltage (proportional to flow velocity)
- ② Electrodes
- ③ Magnetic field
- ④ Field coils

2.1 Technical data

- The following data is provided for general applications. If you require data that is more relevant to your specific application, please contact us or your local representative.
- Additional information (certificates, special tools, software,...) and complete product documentation can be downloaded free of charge from the website (Download Center).

Measuring system

Measuring principle	Faraday's law of induction
Application range	Electrically conductive fluids
Measured value	
Primary measured value	Flow velocity
Secondary measured value	Volume flow, mass flow, electrical conductivity, coil temperature

Design

Features	Flanged version with optimized flow tube.
Modular construction	The measurement system consists of a flow sensor and a signal converter. It is available as compact and as separate version. More information about the signal converter can be found in the relevant documentation.
Compact version	With IFC 100 converter: OPTIFLUX 5100 C
	With IFC 300 converter: OPTIFLUX 5300 C
Remote version	In wall (W) mount version with IFC 100 converter: OPTIFLUX 5100 W
	In field (F), wall (W) or rack (R) mount version with IFC 300 converter: OPTIFLUX 5300 F, W or R
Nominal diameter	DN15...300 / ½...12"
Measurement range	-12...+12 m/s / -40...+40 ft/s

Measuring accuracy

Reference conditions	Medium: water
	Temperature: 20°C / 68°F
	Flow velocity: > 1 m/s / > 3 ft/s
	Operating pressure: 1 bar / 14.5 psig
	Valve closing time variation: < 1 ms
	Wet calibrated on EN 17025 accredited calibration rig by direct volume comparison.
Maximum measuring error	Related to volume flow (MV = measured value).
	These values are related to the pulse / frequency output.
	The additional typical measuring deviation for the current output is $\pm 10 \mu\text{A}$.
	For information refer to <i>Measuring accuracy</i> on page 14.
Repeatability	$\pm 0.1\%$ of MV, minimum 1 mm/s
Long term stability	$\pm 0.1\%$ of MV
Special calibration	On request

Operating conditions

Temperature	
Process temperature	Compact version: -40...+140°C / -40...+284°F
	Remote version: -40...+180°C / -40...+356°F
	For Ex versions different temperatures are valid. Please check the relevant Ex documentation for details.
Maximum temperature change (shock)	120°C / 248°F
Ambient temperature	-40...+65°C / -40...+149°F
	For Ex versions different temperatures are valid. Please check the relevant Ex documentation for details.
Storage temperature	-50...+70°C / -58...+158°F
Pressure	
Ambient	Atmospheric
Nominal flange pressure	Standard:
EN 1092-1	DN200...300: PN10
	DN100...150: PN16
	DN15...80: PN40
ASME B16.5	Standard:
	1...12": 150 lb
	½": 300 lb
	Option:
	1...3": 300 lb
Vacuum load	0 mbar / 0 psi
Pressure ranges for secondary containment	Pressure resistant up to 40 bar / 580 psi
	Burst pressure up to approx. 160 bar / 2320 psi
Chemical properties	
Physical condition	Conductive liquids
Electrical conductivity	Non water:
	DN25...300: $\geq 1 \mu\text{S/cm}$
	DN15: $\geq 5 \mu\text{S/cm}$
	Demineralised cold water:
	DN15...300: $\geq 20 \mu\text{S/cm}$
Permissible gas content (volume)	$\leq 5\%$
Permissible solid content (volume)	IFC 100: $\leq 10\%$
	IFC 300: $\leq 70\%$
Recommended flow velocity	-12...+12 m/s / -40...+40 ft/s

Installation conditions

Installation	Take care that the flow sensor is always fully filled.
	For detailed information refer to <i>Installation</i> on page 15.
Flow direction	Forward and reverse.
	Arrow on flow sensor indicates positive flow direction.

Inlet run	≥ 5 DN (without disturbing flow, after a single 90° bend)
	≥ 10 DN (after a double bend 2x 90°)
	≥ 10 DN (behind a control valve)
Outlet run	≥ 2 DN
Dimensions and weights	For detailed information refer to <i>Dimensions and weights</i> on page 11.

Materials

Sensor housing	DN15...100: stainless steel AISI 316 (1.4408)
	DN150...300: sheet steel (carbon steel)
Measuring tube	ceramic
Connection box (only remote versions)	Standard: polyurethane coated die-cast aluminium
	Option: stainless steel
Grounding rings	Standard:
	DN15...100: not included
	DN150...300: integrated, stainless steel AISI 316L (1.4404)
	Option:
	DN15...100: virtual reference (only with IFC 300 converter)
Gaskets	DN15...100: PTFE
	DN150...300: FPM / FKM O-ring
Measuring electrodes	Standard:
	DN15...100: cermet
	DN150...300: stainless steel AISI 316 Ti (1.4571)
	Option:
DN150...300: platinum, Hastelloy® C, low noise (basis Hastelloy C4, tantalum, titanium)	

Process connections

EN 1092-1	DN200...300: PN10
	DN100..150: PN16
	DN15...80: PN40
ASME	Standard:
	1...12": 150 lb
	½": 300 lb
	Option:
1...3": 300 lb	

Electrical connections

Signal cable	Only for remote systems.
Type A	Standard cable, double shielded. Max. length: 600 m / 1950 ft (dep. on electrical conductivity and measuring sensor). See documentation of the converter for more information.
Type B	Optional cable, triple shielded. Max. length: 600 m / 1950 ft (dep. on electrical conductivity and measuring sensor). See documentation of the converter for more information.

Approvals and certifications

CE Sign	
	This device fulfills the statutory requirements of the EC directives. The manufacturer certifies successful testing of the product by applying the CE mark.
Electromagnetic compatibility	Directive: 2004/108/EC, NAMUR NE21/04
	Harmonized standard: EN 61326-1 : 2006
Low Voltage Directive	Directive: 2006/95/EC
	Harmonized standard: EN 61010 : 2001
Pressure Equipment Directive	Directive: 97/23/EC
	Category I, II or SEP
	Fluid group 1
	Production module H
Other approvals and standards	
Non-Ex	Standard
Hazardous areas	
ATEX	Please check the relevant Ex documentation for details.
	In combination with IFC 100 W converter
	II 2 G or II 2 D
	In combination with IFC 300 C or F converter
	II 2 GD or II 2 (1) GD
	Remote version
II 2 GD	
FM	In combination with IFC 300 C or F converter
	Class I, Div. 2, groups A, B, C and D
	Class II, Div. 2, groups F and G
	Class III, Div. 2, groups F and G
	Only for diameters DN15...100
CSA	In combination with IFC 300 C or F converter
	Class I, Div. 2, groups A, B, C and D
	Class II, Div. 2, groups F and G
	Only for diameters DN15...100
IEC-Ex	pending
NEPSI	GYJ101206 / GYJ101207
	Ex me ia IIC T6...T3
	Ex de ia IIC T6...T3
Custody transfer	Standard: without verification
	Only in combination with IFC 300 converter.
	Option: MI-001, MI-005 type examination certificate
Protection category acc. to IEC 529 / EN 60529	Standard: IP 66/67 (NEMA 4/4X/6)
	Option: IP 68 (NEMA 6P)
Hygiene	Ceramic measuring tube is FDA approved.
Vibration resistance	IEC 68-2-6

2.2 Dimensions and weights

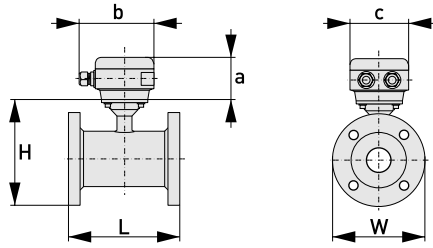
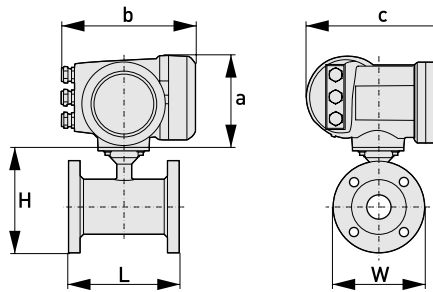
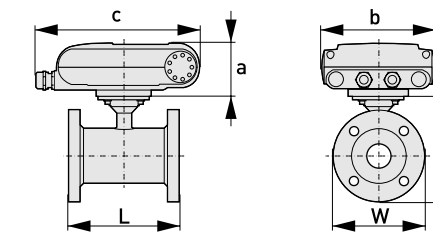
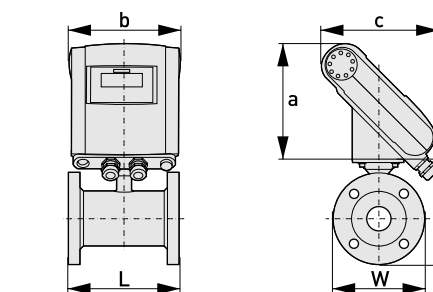
Remote version		<p>a = 77 mm / 3.1"</p> <p>b = 139 mm / 5.5" ①</p> <p>c = 106 mm / 4.2"</p> <p>Total height = H + a</p>
Compact version with IFC 300		<p>a = 155 mm / 6.1"</p> <p>b = 230 mm / 9.1" ①</p> <p>c = 260 mm / 10.2"</p> <p>Total height = H + a</p>
Compact version with IFC 100 (0°)		<p>a = 82 mm / 3.2"</p> <p>b = 161 mm / 6.3"</p> <p>c = 257 mm / 10.1" ①</p> <p>Total height = H + a</p>
Compact version with IFC 100 (45°)		<p>a = 186 mm / 7.3"</p> <p>b = 161 mm / 6.3"</p> <p>c = 184 mm / 7.3" ①</p> <p>Total height = H + a</p>

① The value may vary depending on the used cable glands.

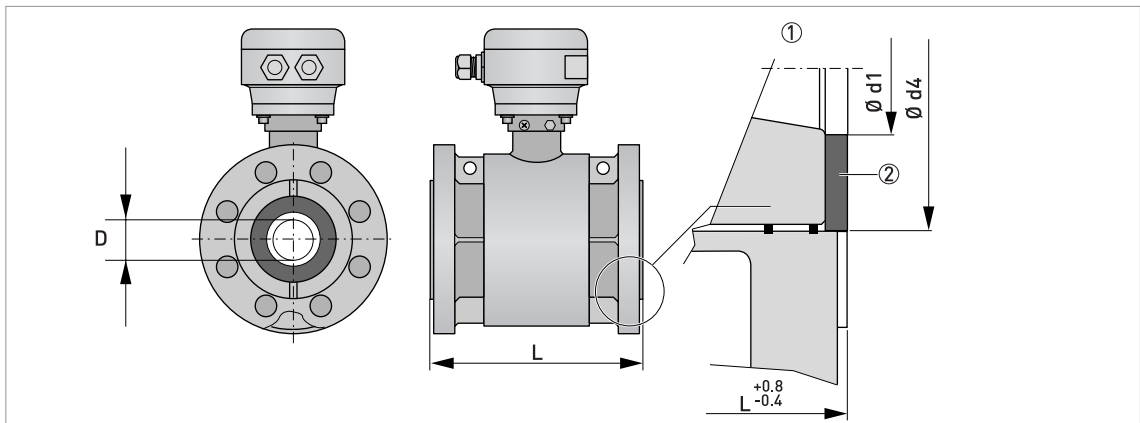

Figure 2-1: Construction details DN15...100

- ① Detail ceramics / flange / gaskets
- ② PTFE sealing ring

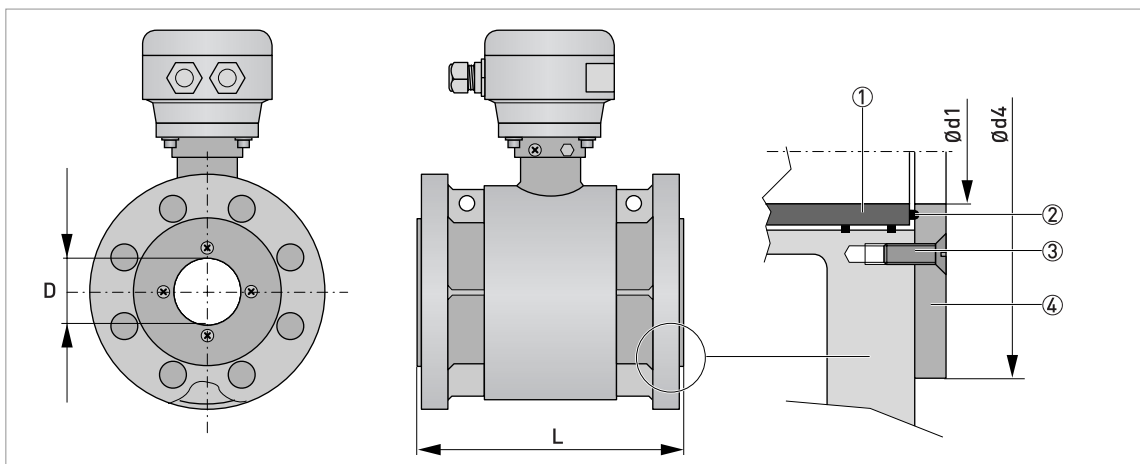

Figure 2-2: Construction details DN150...300

- ① Ceramic liner
- ② O-ring
- ③ Screw
- ④ Grounding ring

- All data given in the following tables are based on standard versions of the sensor only.
- Especially for smaller nominal sizes of the sensor, the converter can be bigger than the sensor.
- Note that for other pressure ratings than mentioned, the dimensions may be different.
- For full information on converter dimensions see relevant documentation.

EN 1092-1

Nominal size	Dimensions [mm]						Approx. weight [kg]
DN	L	H	W	D	Ød1	Ød4	
15	150	127	95	12	15	44	3
25	150	143	115	20	26	46	4
40	150	168	150	30	39	62	6
50	200	184	165	40	51	74	9
80	200	217	200	60	80	106	15
100	250	242	220	80	101	133	21
150	265	355	283	150	150	215	37
200	315	396	342	200	198	270	53
250	365	458	395	250	250	322	87
300	500	493	445	300	300	375	145

ASME B 16.5 150 lb

Nominal size	Dimensions [inches]						Approx. weight [lb]
inch	L	H	W	D	Ød1	Ød4	
1"	5.91	5.47	4.25	0.79	1.02	1.81	8.8
1½"	5.91	6.18	5	1.18	1.54	2.44	13.2
2"	7.87	6.89	6	1.57	2.01	2.91	19.8
3"	7.87	8.39	7.5	2.36	3.15	4.17	33.1
4"	9.84	9.65	9	3.15	3.98	5.24	46.3
6"	10.43	13.98	11	5.91	5.91	8.46	81.6
8"	12.4	15.59	13.5	7.80	7.80	10.63	116.8
10"	14.37	18.03	16	9.84	9.84	12.68	191.8
12"	19.69	19.41	19	11.81	11.81	14.76	366

ASME B 16.5 300 lb

Nominal size	Dimensions [inches]						Approx. weight [lb]
inch	L	H	W	D	Ød1	Ød4	
½"	5.91	5.0	3.74	0.47	0.59	-	6.8
1"	5.91	5.91	4.92	0.79	1.02	1.81	8.8
2"	7.87	7.20	6.50	1.57	2.01	2.91	22.9
3"	7.87	8.86	8.27	2.36	3.15	4.17	40.6

1½": not possible because of ASTM-NUT

- Pressures at 20°C / 68°F.
- For higher temperatures, the pressure and temperature ratings are as per ASME B16.5.

2.3 Measuring accuracy

Reference conditions

- Medium: water
- Temperature: 20°C / 68°F
- Pressure: 1 bar / 14.5 psi

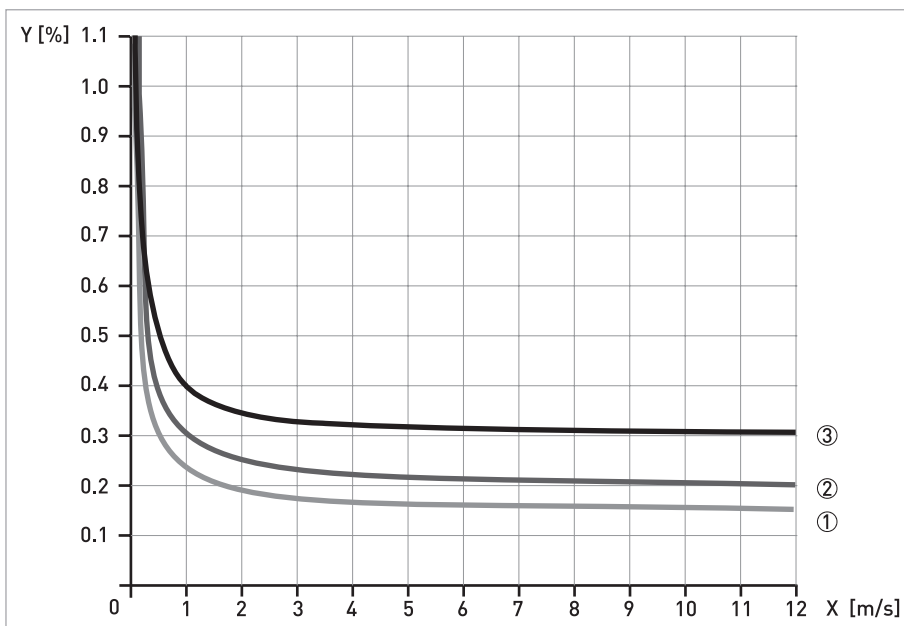

Y [m/s]: flow velocity

Y [%]: deviation from the actual measured value (MV)

Compact with IFC 300	Accuracy	Curve
DN15...100 / ½...4"	±0.15% of MV + 1 mm/s	①
DN150...300 / 6...12"	±0.2% of MV + 1 mm/s	②

Compact with IFC 100	Accuracy	Curve
DN15...300 / ½...12"	±0.3% of MV + 1 mm/s	③

3.1 Notes on installation

Inspect the cartons carefully for damage or signs of rough handling. Report damage to the carrier and to the local office of the manufacturer.

Check the packing list to check if you received completely all that you ordered.

Look at the device nameplate to ensure that the device is delivered according to your order. Check for the correct supply voltage printed on the nameplate.

3.2 Intended use

The **OPTIFLUX 5000 FL** flowmeter measures the volumetric flow rate of electrically conductive liquids, acids, alkaline solutions, pastes and slurries, also with very high solid contents.

3.3 Installation conditions

3.3.1 Inlet and outlet

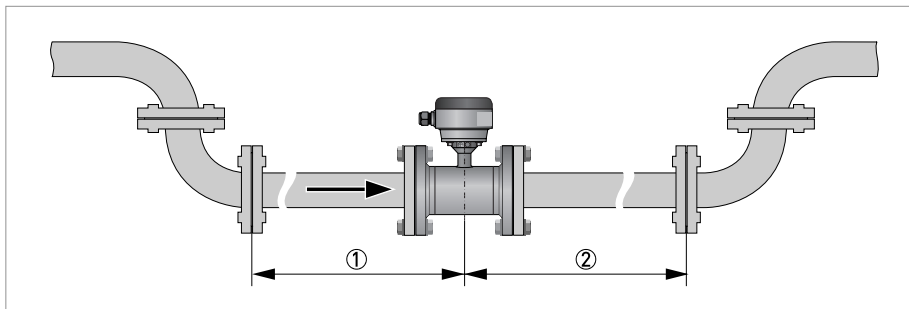

Figure 3-1: Recommended inlet and outlet sections

① ≥ 5 DN

② ≥ 2 DN

3.3.2 Mounting position

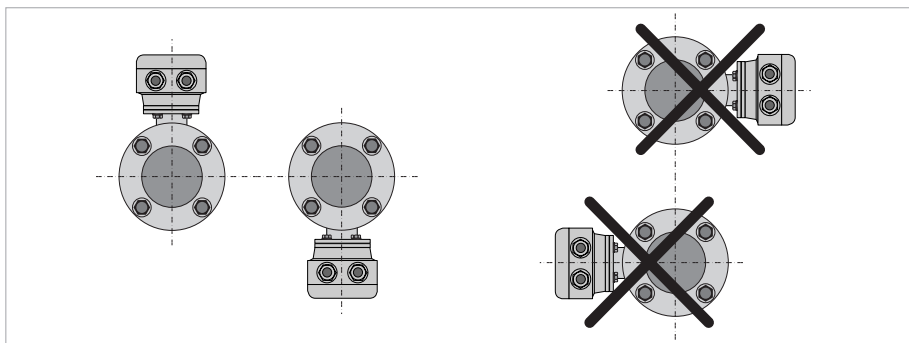

Figure 3-2: Mounting position

3.3.3 Flange deviation

Max. permissible deviation of pipe flange faces:
 $L_{max} - L_{min} \leq 0.5 \text{ mm} / 0.02''$

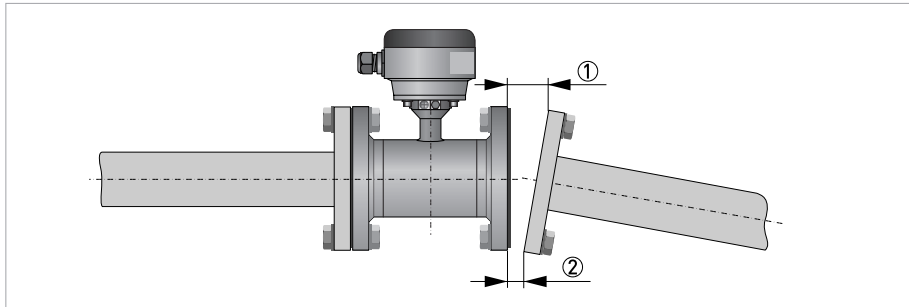

Figure 3-3: Flange deviation

- ① L_{max}
- ② L_{min}

3.3.4 T-section

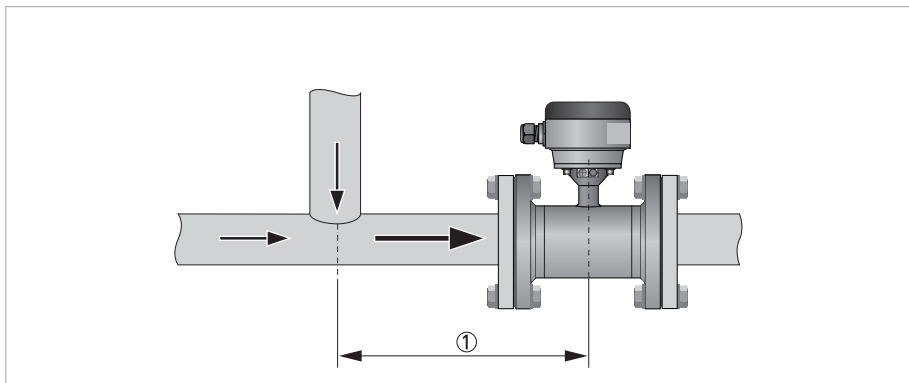

Figure 3-4: Distance after T-sections

- ① $\geq 10 \text{ DN}$

3.3.5 Vibration

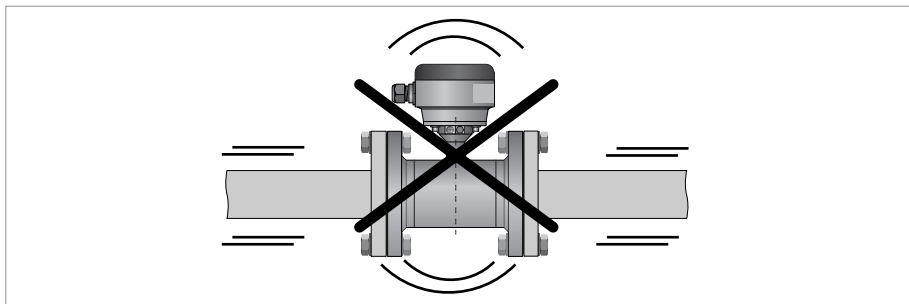

Figure 3-5: Avoid vibrations

3.3.6 Magnetic field

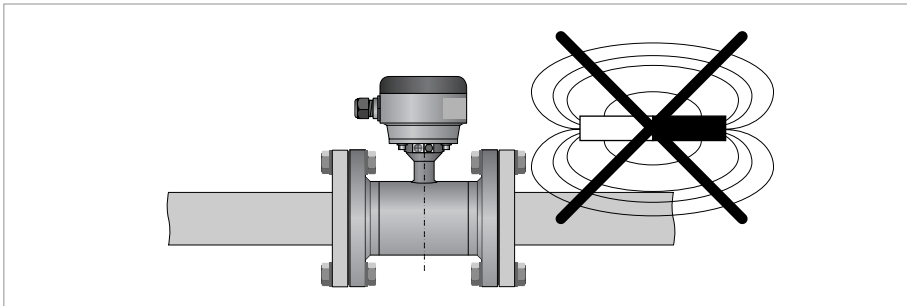

Figure 3-6: Avoid magnetic fields

3.3.7 Bends

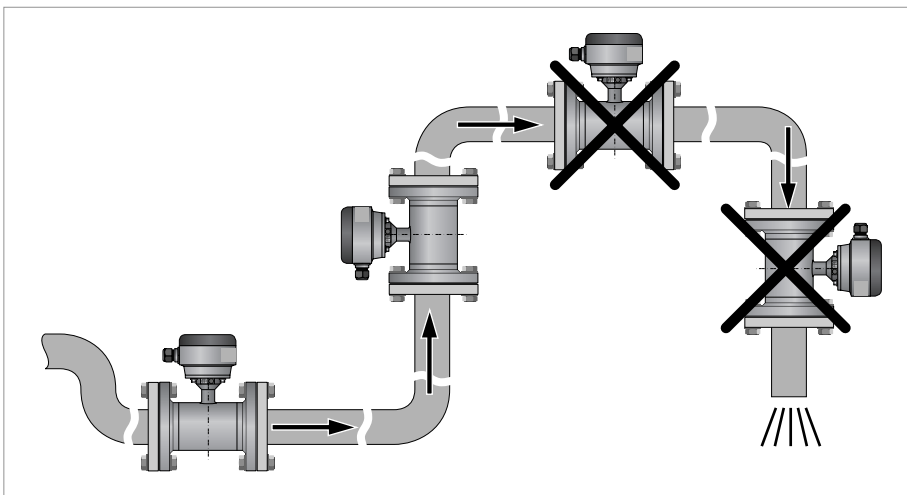

Figure 3-7: Installation in bending pipes

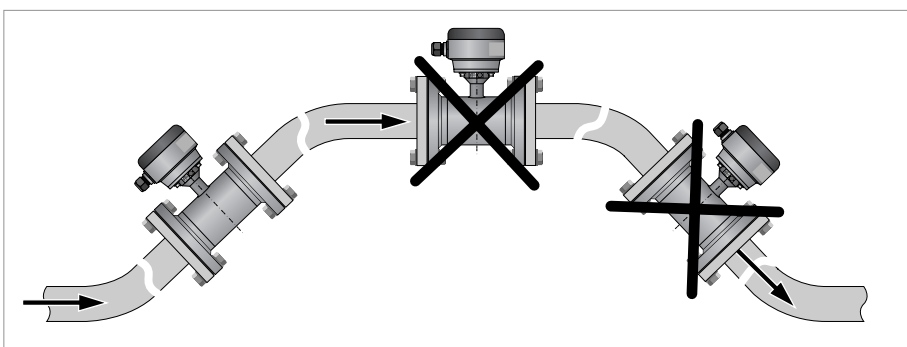

Figure 3-8: Installation in bending pipes

3.3.8 Open discharge

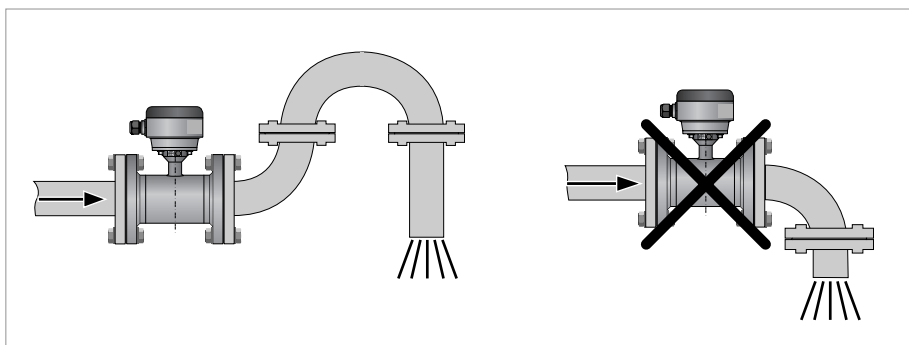

Figure 3-9: Installation before an open discharge

3.3.9 Control valve

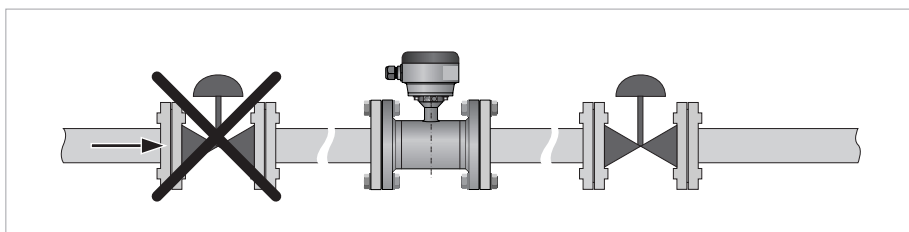

Figure 3-10: Installation before control valve

3.3.10 Air venting

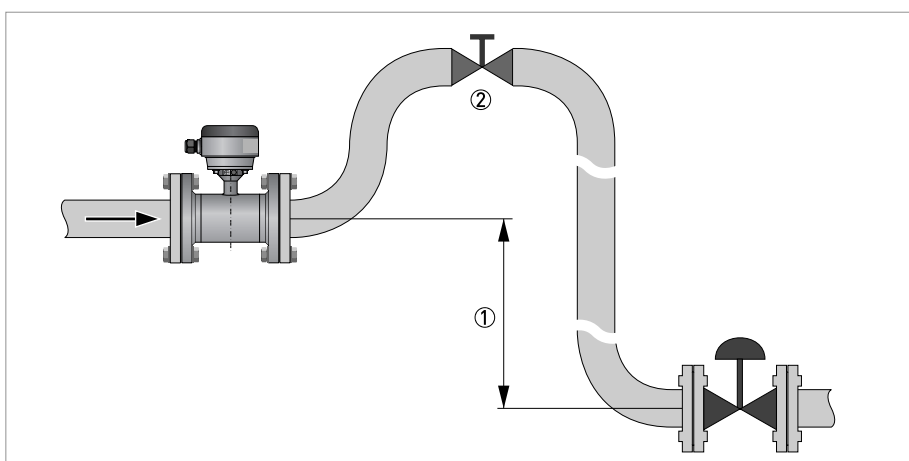

Figure 3-11: Air venting

① ≥ 5 m

② Air ventilation point

3.3.11 Pump

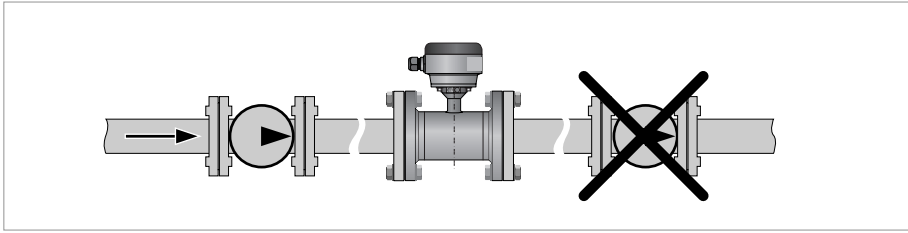

Figure 3-12: Installation after pump

4.1 Safety instructions

All work on the electrical connections may only be carried out with the power disconnected. Take note of the voltage data on the nameplate!

Observe the national regulations for electrical installations!

For devices used in hazardous areas, additional safety notes apply; please refer to the Ex documentation.

Observe without fail the local occupational health and safety regulations. Any work done on the electrical components of the measuring device may only be carried out by properly trained specialists.

Look at the device nameplate to ensure that the device is delivered according to your order. Check for the correct supply voltage printed on the nameplate.

4.2 Grounding

The device must be grounded in accordance with regulations in order to protect personnel against electric shocks.

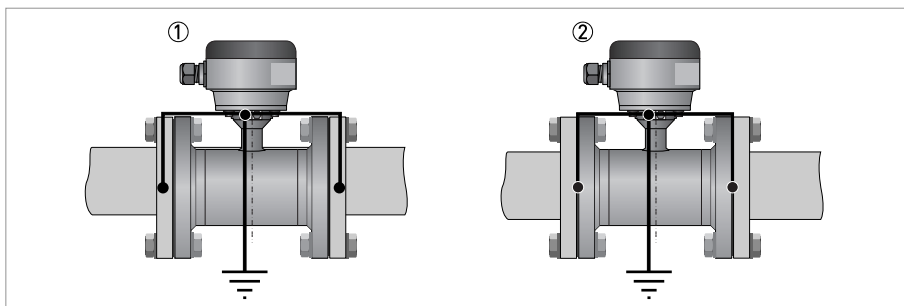

Figure 4-1: Grounding

- ① Metal pipelines, not internally coated. Grounding without grounding rings.
- ② Metal pipelines with internal coating and non-conductive pipelines. Grounding with grounding rings.

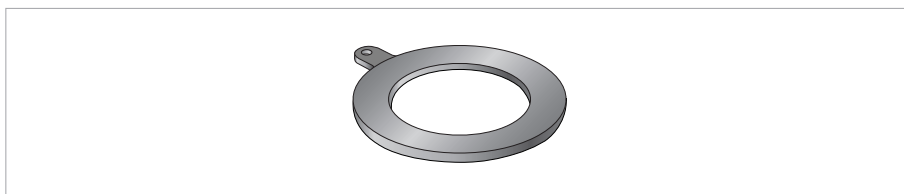

Figure 4-2: Grounding ring number 1

Grounding ring number 1 (for type VN20):

- 3 mm / 0.1" thick (tantalum: 0.5 mm / 0.1")

4.3 Virtual reference for IFC 300 (C, W and F version)

The virtual reference option on the IFC 300 flow converter provides complete isolation of the measurement circuit.

The benefits of virtual reference are that grounding rings or grounding electrodes can be omitted, safety increases by reducing the number of potential leakage points and the installation of the flowmeters is much easier.

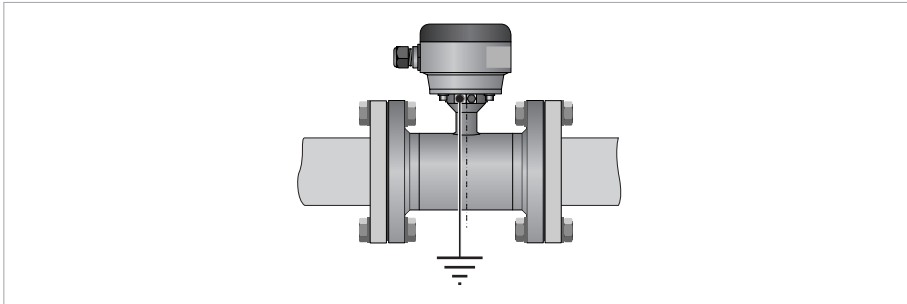

Figure 4-3: Virtual reference

Possible if:

- \geq DN10
- Electrical conductivity $\geq 200 \mu\text{S}/\text{cm}$
- Electrode cable max. 50m., type DS





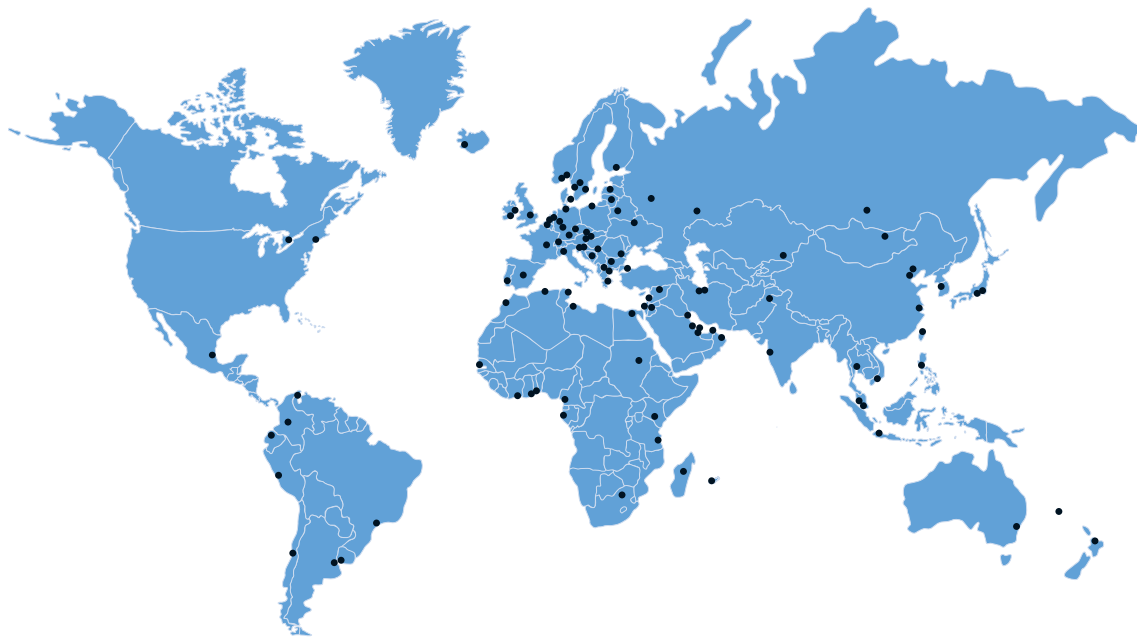

KROHNE product overview

- Electromagnetic flowmeters
- Variable area flowmeters
- Ultrasonic flowmeters
- Mass flowmeters
- Vortex flowmeters
- Flow controllers
- Level meters
- Temperature meters
- Pressure meters
- Analysis products
- Measuring systems for the oil and gas industry
- Measuring systems for sea-going tankers

Head Office KROHNE Messtechnik GmbH
Ludwig-Krohne-Str. 5
D-47058 Duisburg (Germany)
Tel.: +49 (0)203 301 0
Fax: +49 (0)203 301 10389
info@krohne.de

The current list of all KROHNE contacts and addresses can be found at:
www.krohne.com

KROHNE