

Operating Instructions

OPTISWITCH 3300 C

with relay output



Variable area flowmeters

Vortex flowmeters

Flow controllers

Electromagnetic flowmeters

Ultrasonic flowmeters

Mass flowmeters

Level measuring instruments

Communications engineering

Engineering systems & solutions

Switches, counters, displays and recorders

Heat metering

Pressure and temperature

Contents

1 About this document

1.1	Function	4
1.2	Target group	4
1.3	Symbolism used	4

2 For your safety

2.1	Authorised personnel	5
2.2	Appropriate use	5
2.3	Warning about misuse	5
2.4	CE conformity	5
2.5	SIL conformity	6
2.6	Safety instructions for Ex areas	6

3 Product description

3.1	Configuration	7
3.2	Principle of operation	7
3.3	Operation	9
3.4	Storage and transport	9

4 Mounting

4.1	General instructions	10
4.2	Mounting instructions	11

5 Connecting to voltage supply

5.1	Preparing the connection	16
5.2	Connection steps	16
5.3	Wiring plan, single chamber housing	17

6 Set up

6.1	General	20
6.2	Adjustment elements	20
6.3	Function chart	21

7 Maintenance and fault rectification

7.1	Maintenance	23
7.2	Rectify faults	23
7.3	Exchange the electronics	24
7.4	Instrument repair	25

8 Dismounting

8.1	Dismounting procedure	26
8.2	Disposal	26

9 Supplement

9.1	Technical data	27
9.2	Dimensions	31

Supplementary operating instructions manuals



Information:

OPTISWITCH 3300 C is available in different versions. Depending on the selected version, supplementary operating instructions manuals may also come with the shipment. The supplementary operating instructions manuals are listed in section "*Product description*".

Operating instructions manuals for accessories and replacement parts



Tip:

To ensure reliable setup and operation of your OPTISWITCH 3300 C, we offer accessories and replacement parts. The associated documents are:

- Operating instructions manual "*Oscillator*"
- Operating instructions manual "*Lock fitting*"

1 About this document

1.1 Function

This operating instructions manual has all the information you need for quick setup and safe operation. Please read this manual before you start setup.

1.2 Target group

This operating instructions manual is directed to trained, qualified personnel. The contents of this manual should be made available to these personnel and put into practice by them.

1.3 Symbolism used



Information, tip, note

This symbol indicates helpful additional information.



Caution: If this warning is ignored, faults or malfunctions can result.

Warning: If this warning is ignored, injury to persons and/or serious damage to the instrument can result.

Danger: If this warning is ignored, serious injury to persons and/or destruction of the instrument can result.



Ex applications

This symbol indicates special instructions for Ex applications.



List

The dot set in front indicates a list with no implied sequence.



Action

This arrow indicates a single action.



Sequence

Numbers set in front indicate successive steps in a procedure.

2 For your safety

2.1 Authorised personnel

All operations described in this operating instructions manual must be carried out only by trained specialist personnel authorised by the operator. For safety and warranty reasons, any internal work on the instruments must be carried out only by personnel authorised by the manufacturer.

2.2 Appropriate use

OPTISWITCH 3300 C is a sensor for level detection.

Detailed information on the application range of OPTISWITCH 3300 C is available in chapter "*Product description*".

2.3 Warning about misuse

Inappropriate or incorrect use of the instrument can give rise to application-specific hazards, e.g. vessel overfill or damage to system components through incorrect mounting or adjustment.

2.4 General safety instructions

OPTISWITCH 3300 C is a high-tech instrument requiring the strict observance of standard regulations and guidelines. The user must take note of the safety instructions in this operating instructions manual, the country-specific installation standards (e.g. the VDE regulations in Germany) as well as all prevailing safety regulations and accident prevention rules.

2.5 CE conformity

OPTISWITCH 3300 C is in CE conformity with EMC (89/336/EWG), fulfils NAMUR recommendation NE 21 and is in CE conformity with LVD (73/23/EWG).

Conformity has been judged according to the following standards:

- EMC:
 - Emission EN 61326: 1997 (class B)
 - Susceptibility EN 61326: 1997/A1:1998
- LVD: EN 61010-1: 2001

2.6 SIL conformity

OPTISWITCH 3300 C fulfills the requirements of functional safety according to IEC 61508/IEC 61511. You can find further information in the supplementary instructions manual "*Safety Manual - Functional safety (SIL) OPTISWITCH 3XXX*".

2.7 Safety instructions for Ex areas

Please note the Ex-specific safety information for installation and operation in Ex areas. These safety instructions are part of the operating instructions manual and come with the Ex-approved instruments.

3 Product description

3.1 Configuration

Scope of delivery

The scope of delivery encompasses:

- OPTISWITCH 3300 C level sensor
- Documentation
 - this operating instructions manual
 - Supplementary instructions manual "*Plug connector for level sensors*" (optional)
 - Ex specific safety instructions (with Ex versions), if necessary further certificates

Components

OPTISWITCH 3300 C consists of the following components:

- Housing cover
- Housing with electronics
- process fitting with tuning fork

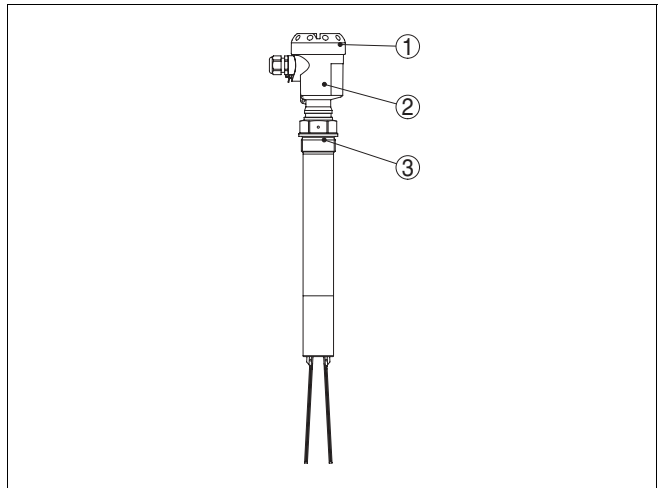

Fig. 1: OPTISWITCH 3300 C with plastic housing

- 1 Housing cover
- 2 Housing with electronics
- 3 Process fitting

3.2 Principle of operation

OPTISWITCH 3300 C is a level sensor with tuning fork for level detection.

Area of application

It is designed for industrial use in all areas of process technology and is preferably used for bulk solids.

Typical applications are overfill and dry run protection. Thanks to its simple and robust measuring system, OPTISWITCH 3300 C is virtually unaffected by the chemical and physical properties of the bulk solid.

It functions even when exposed to strong external vibration or changing products.

Solid detection in water

If OPTISWITCH 3300 C was ordered for detection of solids in water, the tuning fork is adjusted to the density of water. In the air or when covered by water (density: 1 g/cm³/0.036 lbs/in) OPTISWITCH 3300 C signals "uncovered". Only if the vibrating element is also covered with solids (e.g. sand, sludge, gravel etc.) will the sensor signal "covered".

Fault monitoring

The electronics of OPTISWITCH 3300 C continuously monitors the following criteria:

- Correct vibrating frequency
- Line break to the piezo drive

If one of the stated malfunctions is detected or in case of power failure, the electronics takes on a defined switching condition, i.e. the relay deenergises (safe condition).

Physical principle

The tuning fork is piezoelectrically energised and vibrates at its mechanical resonance frequency of approx. 150 Hz. When the tuning fork is submerged in the product, the vibration amplitude changes. This change is detected by the integrated oscillator and converted into a switching command.

Power supply

OPTISWITCH 3300 C is a compact instrument, i.e. it can be operated without external evaluation system. The integrated electronics evaluates the level signal and outputs a switching signal. With this switching signal, a connected device can be directly activated (e.g. a warning system, a PLC, a pump etc.).

The exact range of the power supply is stated in the "*Technical data*" in the "*Supplement*".

3.3 Operation

With the factory setting, products with a density of $>0.02 \text{ g/cm}^3$ ($>0.0008 \text{ lbs/in}^3$) can be measured. The instrument can also be adapted to products with lower density $>0.008 \text{ g/cm}^3$ ($>0.0003 \text{ lbs/in}^3$).

On the electronics module you will find the following indicating and adjustment elements:

- signal lamp for indication of the switching condition (green/red)
- potentiometer for adaptation to the product density
- Mode switch for selecting the switching condition (min./max.)

3.4 Storage and transport

Packaging

Your instrument was protected by packaging during transport. Its capacity to handle normal loads during transport is assured by a test according to DIN 55439.

The packaging of standard instruments consists of environment-friendly, recyclable cardboard. In addition, the sensor is provided with a protective cover of cardboard. For special versions PE foam or PE foil is also used. Dispose of the packaging material via specialised recycling companies.

Storage and transport temperature

- Storage and transport temperature see "*Supplement - Technical data - Ambient conditions*"
- Relative humidity 20 ... 85 %

4 Mounting

4.1 General instructions

Switching point

In general, OPTISWITCH 3300 C can be mounted in any position. The instrument must be mounted in such a way that the vibrating element is at the height of the requested switching point.

Moisture

Use the recommended cables (see chapter "*Connecting to power supply*") and tighten the cable gland.

You can give your OPTISWITCH 3300 C additional protection against moisture penetration by leading the connection cable downward in front of the cable entry. Rain and condensation water can thus drain off. This applies mainly to mounting outdoors, in areas where moisture is expected (e.g. by cleaning processes) or on cooled or heated vessels.

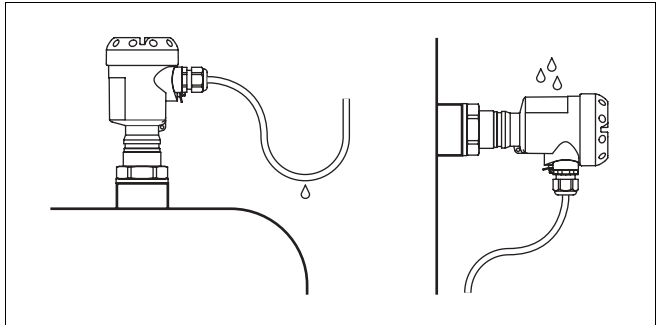

Fig. 2: Measures against moisture penetration

Transport

Do not hold OPTISWITCH 3300 C on the vibrating element. Especially with flange and tube versions, the sensor can be damaged by the weight of the instrument.

Remove the protective cover just before mounting.

Pressure/Vacuum

The process fitting must be sealed if there is gauge or low pressure in the vessel. Before use, check if the seal material is resistant against the measured product and the process temperature.

The max. permissible pressure is stated in the "*Technical data*" in the "*Supplement*" or on the type label of the sensor.

Handling

The vibrating level switch is a measuring instrument and must be treated accordingly. Bending the vibrating element will destroy the instrument.

**Warning:**

The housing must not be used to screw in the instrument! Applying tightening force on the housing can damage its internal mechanical parts.

To screw in, use the hexagon above the thread.

4.2 Mounting instructions

Agitators and fluidization

Agitators, equipment vibration, etc., can cause the level switch to be subjected to strong lateral forces. For this reason, do not use an overly long extension tube for OPTISWITCH 3300 C, but check if you can mount a short level switch on the side of the vessel in horizontal position.

Extreme vibration caused by the process or the equipment, e. g. agitators or turbulence in the vessel e.g. from fluidization, can cause the extension tube of OPTISWITCH 3300 C to vibrate in resonance. This leads to increased stress on the upper weld joint. Should a longer tube version be necessary, you can provide a suitable support or guy directly above the tuning fork to secure the extension tube.



This measure applies particularly to applications in Ex areas. Make sure that the tube is not subjected to bending forces through this measure.

Inflowing medium

If OPTISWITCH 3300 C is mounted in the filling stream, unwanted switching signals may be generated. Mount OPTISWITCH 3300 C at a location in the vessel where no disturbing influence from e.g. filling openings, agitators etc. can occur.

This applies particularly to instrument types with long extension tube.

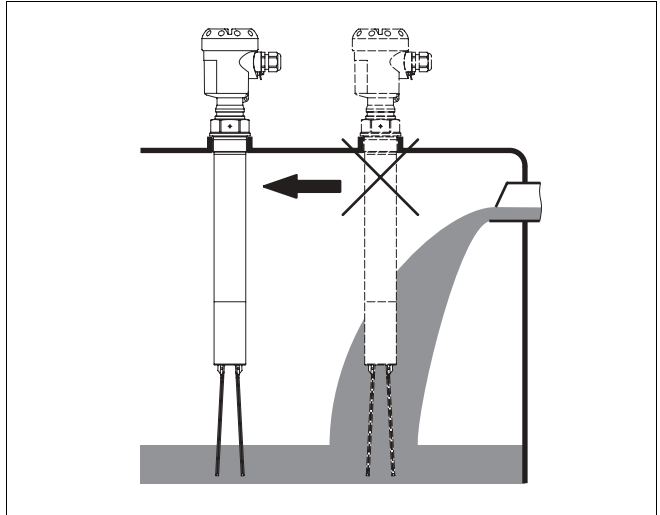

Fig. 3: Inflowing medium

Lock fitting

OPTISWITCH 3300 C can be mounted with a lock fitting for height adjustment. Take note of the pressure information of the lock fitting.

Socket

The vibrating element should protrude into the vessel to avoid buildup. For that reason, avoid using mounting bosses for flanges and screwed fittings. This applies particularly to use with adhesive products.

Material cone

In silos for bulk solids, material cones can form and change the switching point. Please keep this in mind when installing the sensor in the vessel. We recommend selecting an installation location where the vibrating fork detects an average value of the material cone.

The tuning fork must be mounted at a location that takes the arrangement of the filling and emptying apertures into account.

To compensate measurement errors caused by the material cone in cylindrical vessels, the sensor must be mounted at a distance of $d/6$ from the vessel wall.

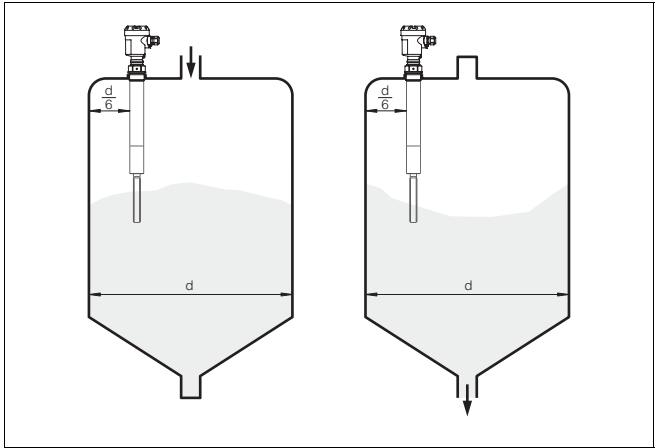

Fig. 4: Filling and emptying centered

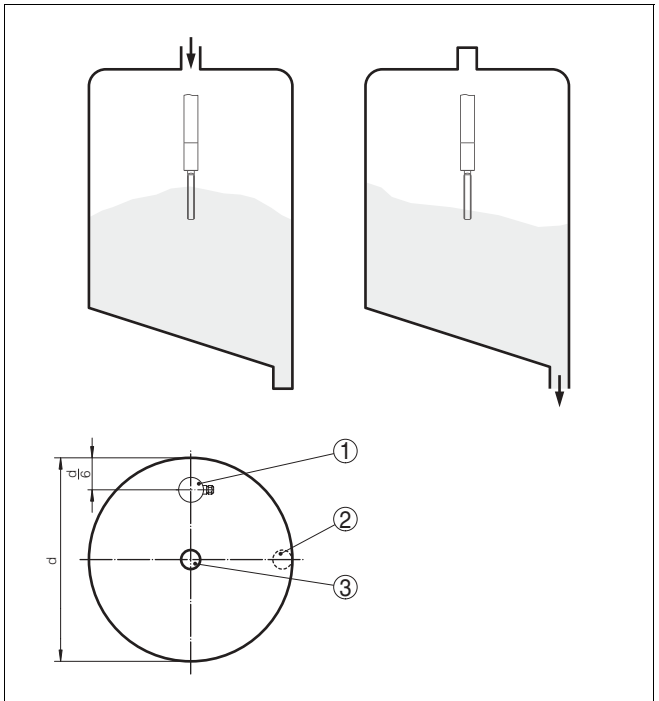

Fig. 5: Filling in the center, emptying laterally

- 1 OPTISWITCH 3300 C
- 2 Emptying opening
- 3 Filling opening

Flows

To minimise flow resistance caused by the tuning fork, OPTISWITCH 3300 C should be mounted in such a way that the surfaces of the blades are parallel to the product movement.



Fig. 6: Orientation of the tuning fork in case of flow

- 1 Marking with screwed version
- 2 Direction of flow

Baffle protection against falling rocks

In applications such as grit chambers or settling basins for coarse sediments, the vibrating element must be protected against damage with a suitable baffle.

This baffle must be manufactured by you.

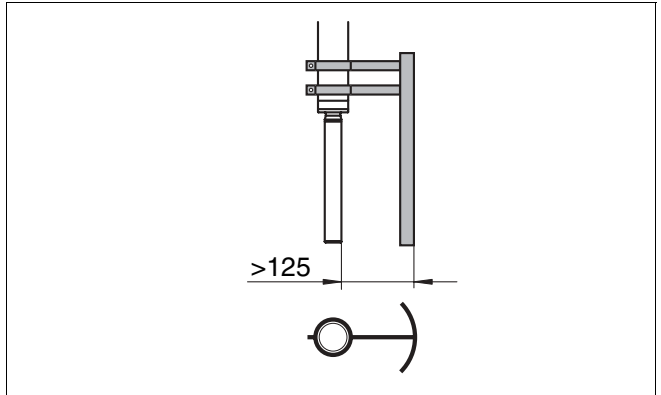

Fig. 7: Baffle protection against damages

5 Connecting to voltage supply

5.1 Preparing the connection

Note safety instructions

Generally not the following safety instructions:

- Connect only in the complete absence of line voltage

Take note of safety instructions for Ex applications



In hazardous areas you should take note of the appropriate regulations, conformity and type approval certificates of the sensors and power supply units.

Select power supply

Connect the power supply according to the following diagrams. Oscillator WE60R is designed in protection class 1. To maintain this protection class, it is absolutely necessary that the ground conductor be connected to the internal ground terminal. Take note of the general installation regulations. As a rule, connect OPTISWITCH 3300 C to vessel ground (PA), or in case of plastic vessels, to the next ground potential. On the side of the housing there is a ground terminal between the cable entries. This connection serves to drain off electrostatic charges. In Ex applications, the installation regulations for hazardous areas must be given priority.

The data for power supply are stated in the "*Technical data*" in the "*Supplement*".

Selecting the connection cable

OPTISWITCH 3300 C is connected with standard cable with round cross-section. An outer cable diameter of 5 ... 9 mm (0.2 ... 0.35 in) ensures the seal effect of the cable entry.

If cable with a different diameter or wire cross section is used, exchange the seal or use an appropriate cable connection.



In hazardous areas, only use approved cable connections for OPTISWITCH 3300 C.

Select connection cable for Ex applications



Take note of the corresponding installation regulations for Ex applications.

5.2 Connection steps



With Ex instruments, the housing cover may only be opened if there is no explosive atmosphere present.

Proceed as follows:

- 1 Unscrew the housing cover
 - 2 Loosen compression nut of the cable entry
 - 3 Remove approx. 10 cm (4 in) of the cable mantle, strip approx. 1 cm (0.4 in) insulation from the ends of the individual wires
 - 4 Insert the cable into the sensor through the cable entry
 - 5 Lift the opening levers of the terminals with a screwdriver (see following illustration)
 - 6 Insert the wire ends into the open terminals according to the wiring plan
 - 7 Press the opening lever of the terminals downward, you will hear the terminal spring closing
 - 8 Check the hold of the wires in the terminals by lightly pulling on them
 - 9 Tighten the compression nut of the cable entry, the seal ring must completely encircle the cable
 - 10 If necessary, carry out a fresh adjustment
 - 11 Screw the housing cover back on
- The electrical connection is hence finished.

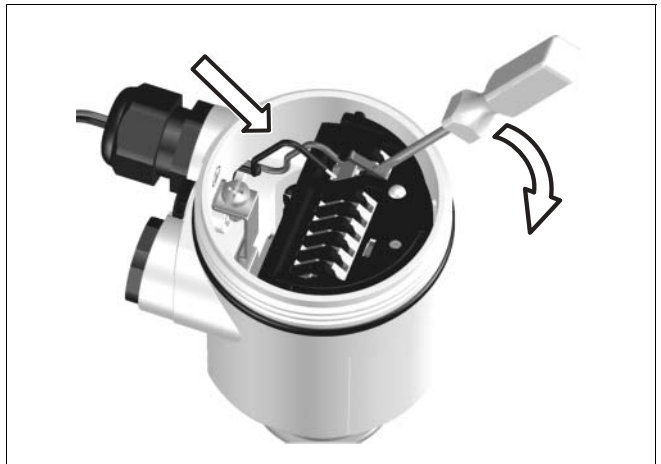

Fig. 8: Connection steps 5 and 6

5.3 Wiring plan, single chamber housing



The following illustrations apply to the non-Ex as well as to the EEx d version.

Housing overview

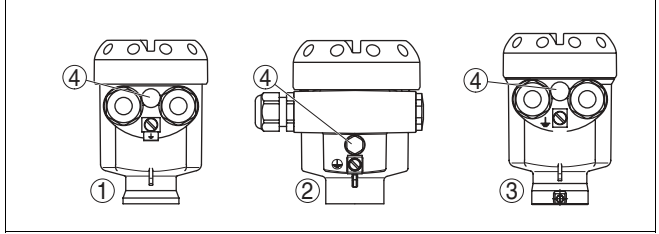

Fig. 9: Material versions, single chamber housing

- 1 Plastic (not with EEx d)
- 2 Aluminium
- 3 Stainless steel (not with EEx d)
- 4 Filter element for pressure compensation (not with EEx d)

Electronics and connection compartment

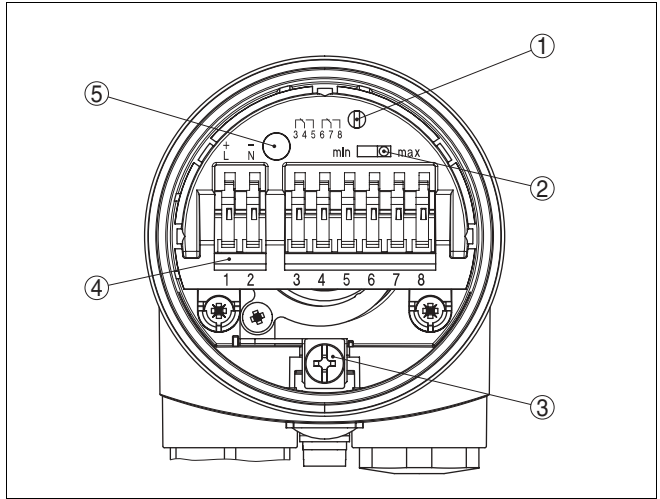

Fig. 10: Electronics and connection compartment

- 1 Potentiometer for switching point adaptation (covered)
- 2 DIL switch for mode adjustment
- 3 Ground terminal
- 4 Screwed terminals
- 5 Control lamp

Wiring plan

We recommend connecting OPTISWITCH 3300 C in such a way that the switching circuit is open when there is a level signal, line break or failure (safe condition).

The relays are always shown in non-operative condition.

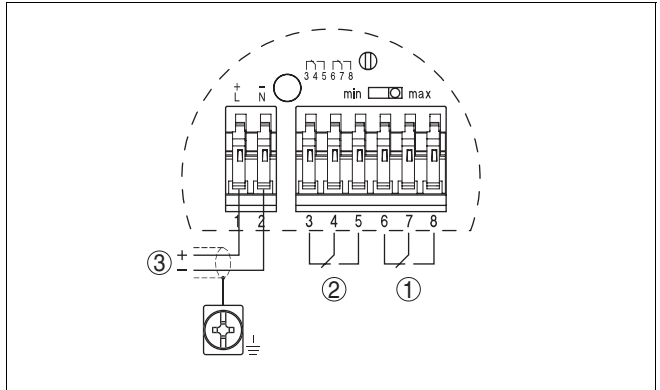

Fig. 11: Wiring plan

- 1 Relay output
- 2 Relay output
- 3 Voltage supply

6 Set up

6.1 General

The numbers in brackets refer to the following illustrations.

Function/Configuration

On the electronics module you will find the following indicating and adjustment elements:

- Potentiometer for switching point adaptation (1)
- DIL switch for mode adjustment - min./max. (2)
- Signal lamp (5)



Note:

As a rule, always set the mode with mode switch (2) before starting the setup of OPTISWITCH 3300 C. The switching output will change if you set the mode switch (2) afterwards. This could possibly trigger other connected instruments or devices.

6.2 Adjustment elements

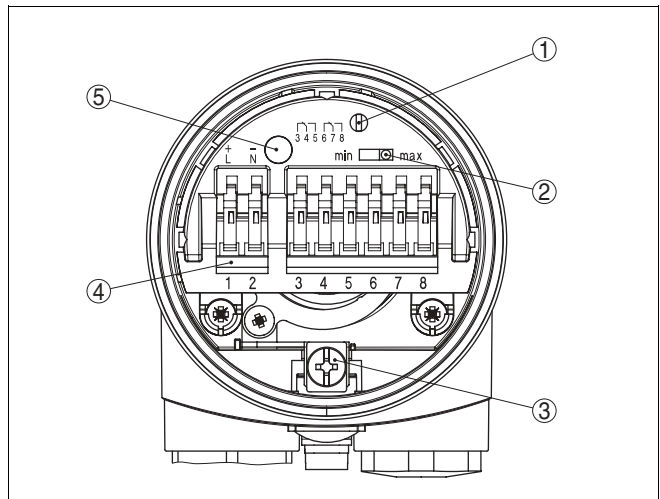

Fig. 12: Oscillator WE60R - Relay output

- 1 Potentiometer for switching point adaptation
- 2 DIL switch for mode adjustment
- 3 Ground terminal
- 4 Screwed terminals
- 5 Control lamp

Switching point adaptation (1) With the potentiometer you can adapt the switching point to the solid. It is already preset and must only be modified in special cases.

By default, the potentiometer of OPTISWITCH 3300 C is set to the right stop ($>0.02 \text{ g/cm}^3$ or $>0.0008 \text{ lbs/in}^3$). In case of very light-weight solids, turn the potentiometer to the left stop ($>0.008 \text{ g/cm}^3$ or $>0.0003 \text{ lbs/in}^3$). OPTISWITCH 3300 C will thus be more sensitive and can detect light-weight solids more reliably.

For instruments detecting solids in water, these values are not applicable. The potentiometer is preset and must not be changed.

Mode adjustment (2) With the mode adjustment (min./max.) you can change the switching condition of the relay. You can set the required mode acc. to the "Function chart" (max. - max. detection or overflow protection, min. - min. detection or dry run protection).







We recommend connecting according to the quiescent current principle (replay contact deenergizes when reaching the switching point), because the relay takes on the same (safe) condition if a failure is detected.











Signal lamp (5) Control lamp for indication of the switching condition.

- green = relay energized
- red = relay deenergized
- red (flashing) = failure

6.3 Function chart

The following chart provides an overview of the switching conditions depending on the adjusted mode and level.

	Level	Switching status	Control lamp
Mode max. Overflow protection		 Relay energized	 Green
Mode max. Overflow protection		 Relay deenergized	 red

	Level	Switching status	Control lamp
Mode min. Dry run protection		 Relay energized	 Green
Mode min. Dry run protection		 Relay deenergized	 red
Failure of the supply voltage (min./max. mode)	any	 Relay deenergized	
Failure	any	 Relay deenergized	 flashes red

7 Maintenance and fault rectification

7.1 Maintenance

When used as directed in normal operation, OPTISWITCH 3300 C is completely maintenance free.

7.2 Rectify faults

Causes of malfunction

OPTISWITCH 3300 C offers maximum reliability. Nevertheless faults can occur during operation. These may be caused by the following, e.g.:

- Sensor
- Process
- Power supply
- Signal processing

Fault rectification

The first measure to be taken is to check the output signal. In many cases, the causes can be determined this way and the faults rectified.

Checking the switching signal

- ? OPTISWITCH 3300 C signals "covered" when the vibrating element is not submerged (overflow protection)
- ? OPTISWITCH 3300 C signals "uncovered" when the vibrating element is submerged (dry run protection)
 - Supply voltage too low
 - Check the power supply
 - Electronics defective
 - Press the mode switch (min./max.). If the instrument then changes the mode, the instrument may be mechanically damaged. Should the switching function in the correct mode still be faulty, return the instrument for repair.
 - Push the mode switch. If the instrument then does not change the mode, the oscillator may be defective. Exchange the oscillator.
 - Check if there is buildup on the vibrating element, and if so, remove it.
 - Unfavourable installation location
 - Mount the instrument at a location in the vessel where no dead zones or mounds can form.
 - Check if the vibrating element is covered by buildup on the socket.

- Wrong mode selected
 - Set the correct mode on the mode switch (max.: overfill protection; min.: dry run protection). Wiring should be carried out according to the quiescent current principle.

? Signal lamp flashes red

- Electronics has detected a failure
 - Exchange instrument or return instrument for repair

7.3 Exchange the electronics

In general, all oscillators of series WE60 can be interchanged. If you want to use an oscillator with a different signal output, you can download the corresponding operating instructions manual from our homepage under Downloads.



With EEx d instruments, the housing cover must only be opened if there is no explosive atmosphere.

Proceed as follows:

- 1 Switch off power supply
- 2 Unscrew the housing cover
- 3 Lift the opening levers of the terminals with a screwdriver
- 4 Pull the connection cables out of the terminals
- 5 Loosen the two screws with a screw driver (Torx size T10 or slot 4)

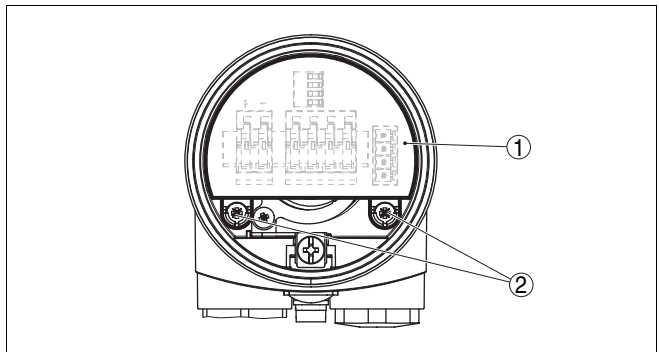

Fig. 13: Loosen the screws

- 1 Electronics module
- 2 Screws (2 pcs.)

- 6 Remove the old oscillator
- 7 Compare the new oscillator with the old one. The type label of the oscillator must correspond to that of the old oscillator. This applies particularly to instruments used in hazardous areas.
- 8 Compare the settings of the two oscillators. Set the adjustment elements of the new oscillator to the same setting of the old one.

**Information:**

Make sure that the housing is not rotated during the electronics exchange. Otherwise the plug may be in a different position later.

- 9 Insert the oscillator carefully. Make sure that the plug is in the correct position.
 - 10 Tighten the two screws with a screwdriver (Torx size T10 or slot 4).
 - 11 Insert the wire ends into the open terminals according to the wiring plan
 - 12 Press the opening lever of the terminals downward, you will hear the terminal spring closing
 - 13 Check the hold of the wires in the terminals by lightly pulling on them
 - 14 Check the tightness of the cable entry. The seal ring must completely encircle the cable.
 - 15 Screw the housing cover back on
- The electronics exchange is now finished.

7.4 Instrument repair

If a repair is necessary, please proceed as follows:

You can download a return form from our website http://www.krohne-mar.com/fileadmin/media-lounge/PDF-Download/Specimen_e.pdf.

By doing this you help us carry out the repair quickly and without having to call back for needed information.

- Print and fill out one form per instrument
- Clean the instrument and pack it damage-proof
- Attach the completed form and possibly also a safety data sheet to the instrument

8 Dismounting

8.1 Dismounting procedure

**Warning:**

Before dismounting, be aware of dangerous process conditions such as e.g. pressure in the vessel, high temperatures, corrosive or toxic products etc.

Take note of chapters "*Mounting*" and "*Connecting to power supply*" and carry out the listed steps in reverse order.



With Ex instruments, the housing cover may only be opened if there is no explosive atmosphere present.

8.2 Disposal

The instrument consists of materials which can be recycled by specialised recycling companies. We use recyclable materials and have designed the electronic modules to be easily separable.

WEEE directive 2002/96/EG

This instrument is not subject to the WEEE directive 2002/96/EG and the respective national laws (in Germany, e.g. ElektroG). Pass the instrument directly on to a specialised recycling company and do not use the municipal collecting points. These may be used only for privately used products according to the WEEE directive.

Correct disposal avoids negative effects to persons and environment and ensures recycling of useful raw materials.

Materials: see "*Technical data*"

If you cannot dispose of the instrument properly, please contact us about disposal methods or return.

9 Supplement

9.1 Technical data

General data

Material 316L corresponds to 1.4404 or 1.4435

Materials, wetted parts

- | | |
|---|-------------------|
| – Process fitting - thread | 316L |
| – Process fitting - flange | 316L |
| – Process seal | Klingersil C-4400 |
| – Tuning fork | 316L |
| – Extension tube \varnothing 43 mm (1.7 in) | 316L |

Materials, non-wetted parts

- | | |
|---|---|
| – Housing | Plastic PBT (Polyester), Alu die-casting powder-coated, 316L |
| – Seal ring between housing and housing cover | NBR (stainless steel housing), silicone (Alu/plastic housing) |
| – Ground terminal | 316L |

Weight

- | | |
|--------------------------------|-------------------------------|
| – with plastic housing | 1500 g (53 oz) |
| – with Aluminium housing | 1950 g (69 oz) |
| – with stainless steel housing | 2300 g (81 oz) |
| – Extension tube | approx. 2000 g/m (21.5 oz/ft) |

Sensor length	0.3 ... 6 m (1 ... 20 ft)
---------------	---------------------------

Output variable

Output	relay output (DPDT), 2 floating spdts
--------	---------------------------------------

Turn-on voltage

- | | |
|--------|--------------------|
| – min. | 10 mV |
| – max. | 253 V AC, 253 V DC |

Switching current

- | | |
|--------|----------------|
| – min. | 10 μ A |
| – max. | 3 A AC, 1 A DC |

Breaking capacity

- min. 50 mW
- max.

750 VA AC, 54 W DC

If inductive loads or stronger currents are switched through, the gold plating on the relay contact surface will be permanently damaged. The contact is then no longer suitable for switching low-level signal circuits.

Contact material (relay contacts)

AgNi or AgSnO and Au plated

Modes (adjustable)

min./max.

Integration time

- when immersed approx. 0.5 s
- when laid bare approx. 1 s

Ambient conditions

Ambient temperature on the housing -40 ... +80 °C (-40 ... +176 °F)

Storage and transport temperature -40 ... +80 °C (-40 ... +176 °F)

Process conditions

Parameter Limit level of solids

Process pressure -1 ... 16 bar/-100 ... 1600 kPa (-14.5 ... 232 psi)

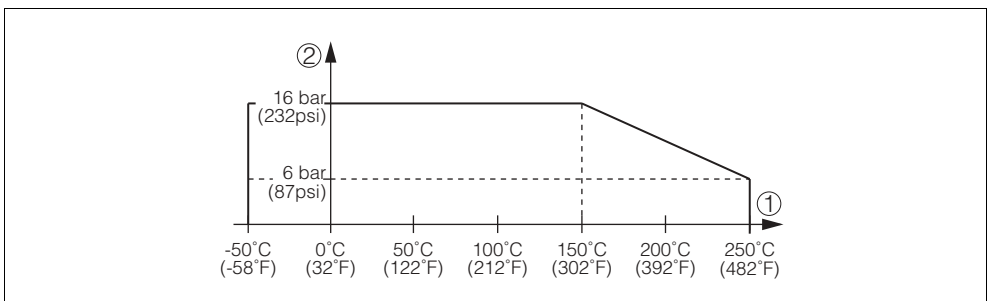

Fig. 14: Process pressure - Product temperature

1 Product temperature

2 Process pressure

OPTISWITCH 3300 C of 316L

-50 ... +150 °C (-58 ... +302 °F)

Process temperature (thread or flange temperature) with temperature adapter (option) -50 ... +250 °C (-58 ... +482 °F)

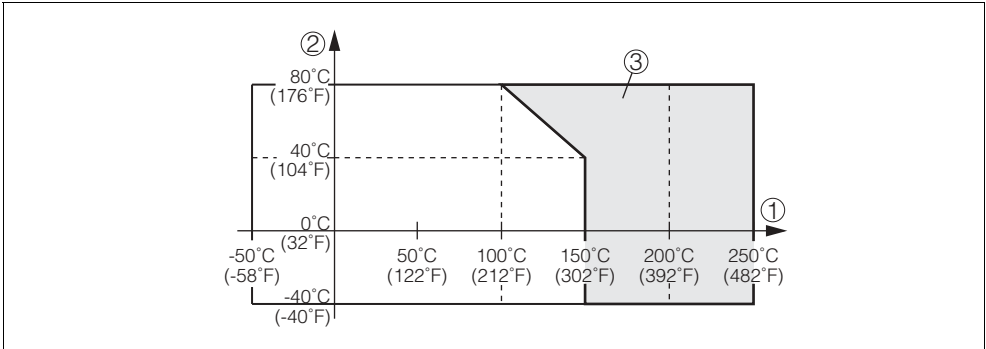

Fig. 15: Ambient temperature - Product temperature

- 1 Product temperature
- 2 Ambient temperature
- 3 Temperature range with temperature adapter

Density

- Standard >0.02 g/cm³ (0.0007 lbs/in³)
- adjustable >0.008 g/cm³ (0.0003 lbs/in³)

Electromechanical data

Cable entry/plug (dependent on the version)

- Single chamber housing
 - 1x cable entry M20x1.5 (cable-ø 5 ... 9 mm), 1x blind stopper M20x1.5, attached 1x cable entry M20x1.5
 - or:
 - 1x cable entry ½ NPT, 1x blind stopper ½ NPT, 1x cable entry ½ NPT
 - or:
 - 1x plug M12x1, 1x blind stopper M20x1.5
- Spring-loaded terminals for wire cross-section up to 1.5 mm² (0.0023 in²)

Adjustment elements

Mode switch

- | | |
|--------|---------------------------------------|
| – min. | Min. detection or dry run protection |
| – max. | Max. detection or overflow protection |
-

Voltage supply

- | | |
|-------------------|---|
| Supply voltage | 20 ... 253 V AC, 50/60 Hz, 20 ... 72 V DC (at U >60 V DC, the ambient temperature can be max. 50 °C/122 °F) |
| Power consumption | 1 ... 8 VA (AC), approx. 1.3 W (DC) |
-

Electrical protective measures

- | | |
|----------------------|-------------|
| Protection | IP 66/IP 67 |
| Overvoltage category | III |
| Protection class | I |
-

Approvals¹⁾

ATEX II 1/2G, 2G EExd d IIC T6

ATEX II 1/2 D IP66 T

¹⁾ Deviating data in Ex applications: see separate safety instructions.

9.2 Dimensions

OPTISWITCH 3300 C

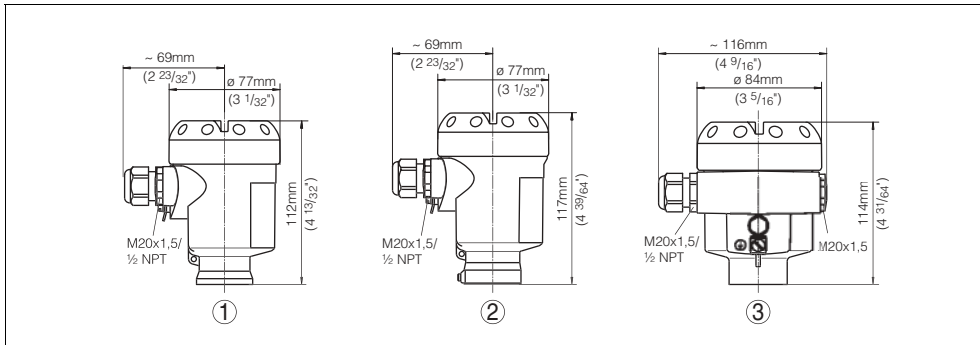

Fig. 16: Housing versions

- 1 Plastic housing
- 2 Stainless steel housing
- 3 Aluminium housing

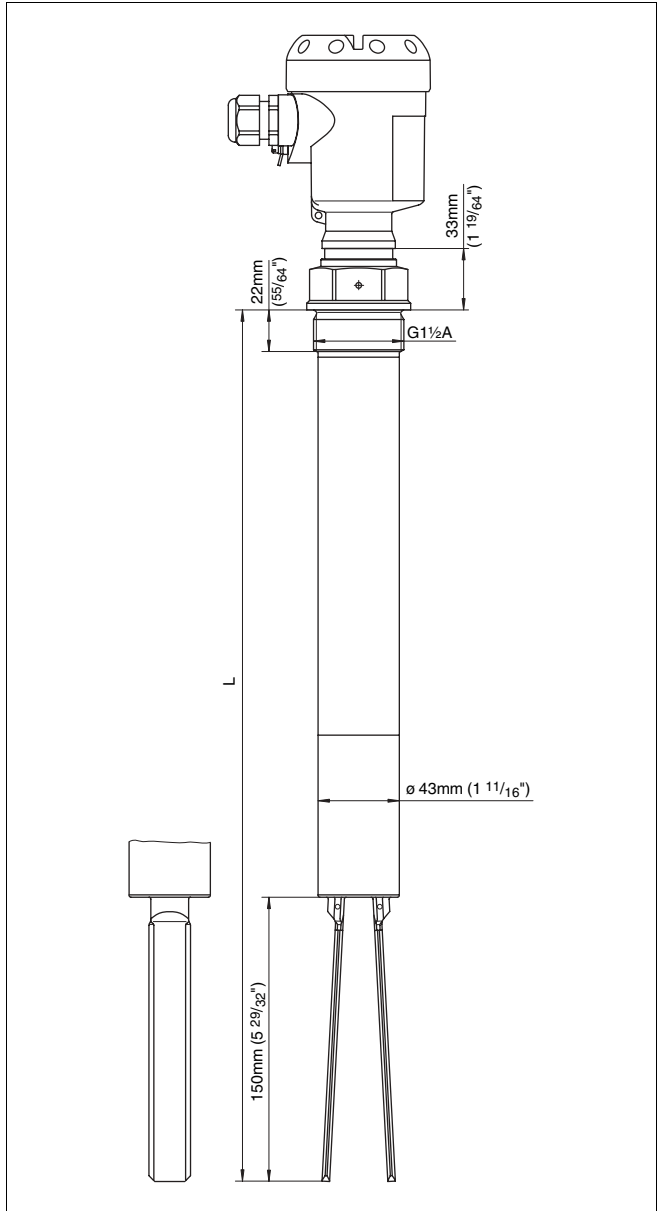

Fig. 17: OPTISWITCH 3300 C, threaded version G1 1/2 A
 L = Sensor length, see "Technical data"

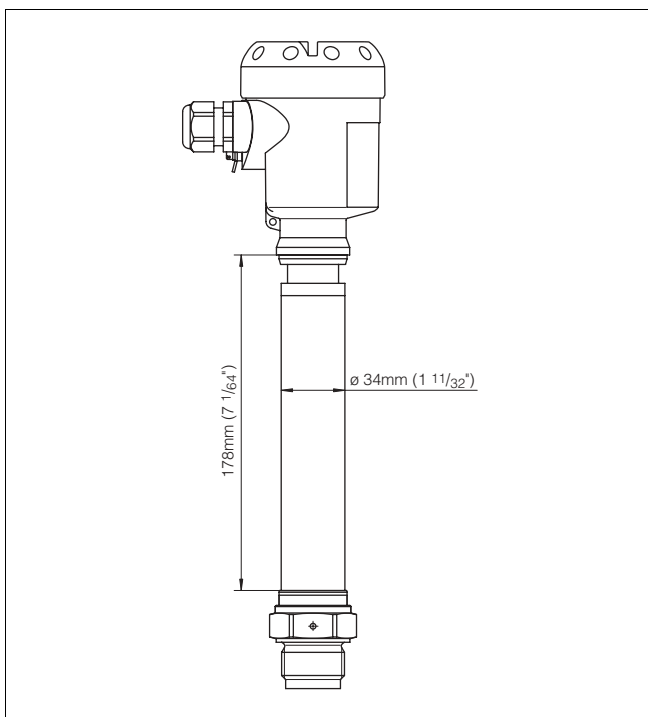

Fig. 18: Temperature adapter

Subject to change without notice