

Industrial Grade **PVDF** **TURBINE HOUSING** Owner's Manual

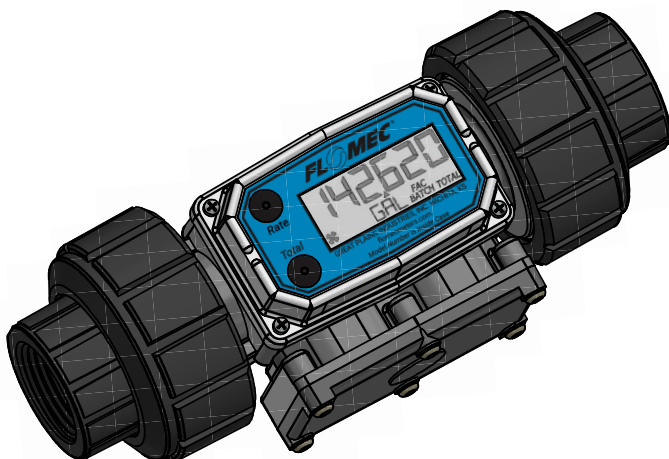

Turbine shown here with Computer Electronics which are sold separately.

To the owner . . .

Congratulations on receiving your FLOMEC® Industrial Grade Turbine. We are pleased to provide you with a product designed to give you maximum reliability and efficiency.

Our business is the design, manufacture, and marketing of liquid handling, agricultural, and recreational products. We succeed because we provide customers with innovative, reliable, safe, timely, and competitively-priced products. We pride ourselves in conducting our business with integrity and professionalism.

We are proud to provide you with a quality product and the support you need to obtain years of safe, dependable service.



Victor Lukic, President
Great Plains Industries, Inc.

TABLE OF CONTENTS

General Information.....	2
Installation	4
Operation.....	5
Maintenance.....	5
Troubleshooting.....	7
Model Number Chart.....	7
Specifications	8
Parts	9
Service.....	10
Agency Approvals Table	11

GENERAL INFORMATION

This manual will assist you in installing and maintaining your PVDF turbine housing. (See Figure 1) Information on computer electronics and accessory modules are contained in other manuals. Please reference those as necessary.

Figure 1

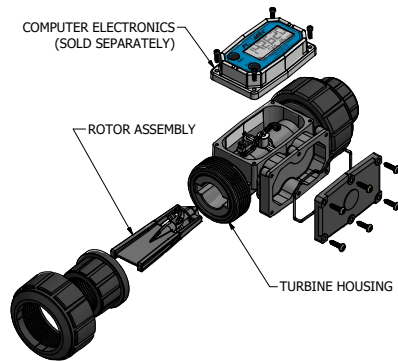

For best results, take the time to fully acquaint yourself with all information about all components of your FLOMEC Electronic Digital Metering System prior to installation and use. If you need assistance, contact the distributor from whom you purchased your turbine.

SAFETY INSTRUCTIONS



This symbol is used throughout the manual to call your attention to safety messages.

WARNING

WARNINGS alert you to the potential for personal injury.

CAUTION

CAUTIONS call your attention to practices or procedures which may damage your equipment.

NOTES give information that can improve efficiency of operations.

It is your responsibility to make sure that all operators have access to adequate instructions about safe operating and maintenance procedures.

Read Me!

For your safety, review the major warnings and cautions below before operating your equipment.

WARNING

The apparatus enclosure may contain aluminum and is considered to constitute a potential risk of ignition by impact or friction. Care must be taken into account during installation and use to prevent impact or friction.

WARNING

Part of the enclosure is constructed from plastic. To prevent the risk of electrostatic sparking the plastic surface should only be cleaned with a damp cloth.

1. This equipment is approved to handle only fluids that are compatible with all materials of construction.
2. When measuring flammable liquids, observe precautions against fire or explosion.
3. When handling hazardous liquids, always follow the liquid manufacturer's safety precautions.
4. When working in hazardous environments, always exercise appropriate safety precautions.
5. Always dispose of used cleaning solvents in a safe manner according to the solvent manufacturer's instructions.
6. During turbine removal, liquid may spill. Follow the liquid manufacturer's safety precautions for clean up of minor spills.
7. Do not blow compressed air through the turbine.
8. Do not allow liquids to dry inside the turbine.
9. Handle the rotor carefully. Even small scratches or nicks can affect accuracy.
10. When tightening the turbine, do not use a wrench or pliers to tighten the turbine. Hand tighten only.
11. For best results, always verify accuracy before use.

Product Description

FLOMEC Industrial Meter Turbines are identified by the internal diameter of the inlet and outlet.

Model 05 - 1/2 inch

Model 10 - 1 inch

Each turbine is designed to work with on-board computer electronics and/or with one of several accessory modules that can interface to a wide variety of reporting and collecting devices.

Liquid flows through the turbine housing causing an internal rotor to spin. As the rotor spins, an electrical signal is generated in the pickup coil. The electrical signal provides the output necessary to operate the on-board computer electronics for local indication directly on the turbine or one of several accessory modules that transmit the signal to external equipment.

Upon receipt, examine your meter for visible damage. The turbine is a precision measuring instrument and should be handled as such. Remove the protective plugs and caps for a thorough inspection. If any items are damaged or missing, contact your distributor.

Make sure the turbine model meets your specific needs. Refer to the Specifications Section and confirm the following:

1. The flowrate is within the limits of your model.
2. The liquid is compatible with the turbine's wetted components.
3. The system's pressure does not exceed the turbine's maximum pressure rating.

Each FLOMEC® Turbine has a unique identification number that includes the Serial Number, K-Factor and Manufacturing Date. This identification number is etched into the surface of the turbine. Record this identification number in the back of the Owner's Manual in the space provided.

INSTALLATION

All FLOMEC turbines are designed to measure flow in only one direction. The direction is indicated by the arrow cast-molded in the turbine outlet. If the opposite direction is desired, and you are using on-board computer electronics, rotate the computer electronics 180 degrees prior to installation.

Figure 2

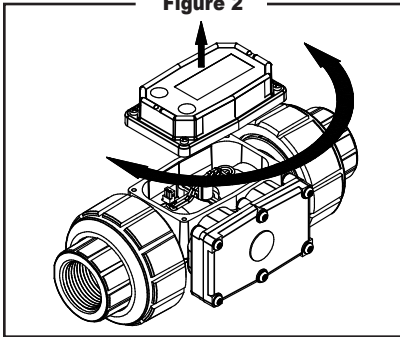

Flow altering devices such as elbows, valves, and reducers can affect accuracy. The following recommended guidelines are given to enhance accuracy and maximize performance. Distances given here are minimum requirements; double them for desired straight pipe lengths.

Upstream from the turbine, allow a minimum straight pipe length at

least 10 times the internal diameter of the turbine. For example, with the 1 inch turbine, there should be 10 inches (25.4 cm) of straight pipe immediately upstream. The desired upstream straight pipe length is 20 inches (50.8 cm).

Downstream from the turbine, allow a minimum straight pipe length at least 5 times the internal diameter of your turbine. For example, with the 1 inch turbine, there should be 5 inches (12.7 cm) of straight pipe immediately downstream. The desired downstream distance is 10 inches (25.4 cm).

A typical back pressure of 5 to 50 PSI (0.34 to 3.4 bar) will prevent cavitation. Create back pressure by installing a control valve on the downstream side of the meter at the proper distance detailed above.

Foreign material in the liquid being measured can clog the turbine's rotor and adversely affect accuracy. If this problem is anticipated or experienced, install screens to filter impurities from incoming liquids.

Model 05

Maximum Particulate Size

Inches: 0.005

Microns: 125

Mesh: 120

Standard Sieve: 125 µm

Alternative Sieve: No. 120

Model 10

Maximum Particulate Size

Inches: 0.018

Microns: 500

Mesh: 35

Standard Sieve: 500 µm

Alternative Sieve: No. 35

To ensure accurate measurement, remove all air from the system before use. To purge the system of air:

1. Ensure some back pressure exists on the turbine in the line.
2. Open the discharge valve or

nozzle and allow fluid to completely fill the system. Make sure the stream is full and steady.

3. Close the discharge valve or nozzle.
4. Start normal operations.

Each turbine contains a removable back coverplate. Leave the coverplate installed unless accessory modules specify removal.

Connections

1. To protect against leakage, seal all threads with an appropriate sealing compound. Make sure the sealing compound does not intrude into the flow path.
2. Make sure the flow direction arrow on housing back is pointed in the direction of the flow.
3. Install union ring over pipe end prior to installing pipe fitting.
4. Install pipe fittings on pipe ends, and tighten.
5. Tighten union ring to the turbine. Make sure O-ring is positioned in housing ends. Do not use a wrench or pliers. Hand tighten only.

NOTE: If connecting to new male threads, burrs and curls can adversely affect accuracy. Correct the problem prior to turbine installation.

Verify accuracy using the procedure found in the Operation Section.

OPERATION

Verify Accuracy

Before use, check the turbine's accuracy and verify calibration.

1. Make sure there is no air in the system.

2. Measure an exact known volume into an accurate container.
3. Verify the volume against the readout or recording equipment.

NOTE: If necessary, use a correction factor to figure final volume.

For best results, accuracy should be verified periodically as part of a routine maintenance schedule.

MAINTENANCE

Remove the Turbine

⚠ WARNING

During turbine removal, liquid may spill. Follow the liquid manufacturer's safety precautions for clean up of minor spills.

1. Drain all liquid from the turbine. Wear protective clothing as necessary.
2. Loosen both union rings at the ends of the turbine.
3. If the turbine is not immediately installed again, cap lines as necessary.

Replace Internal Parts

1. Remove the turbine from the system. See Figure 3.

Figure 3

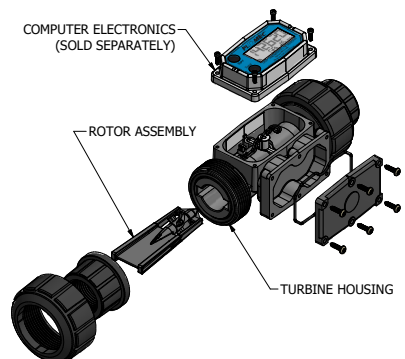

2. Use your fingers to gently remove the rotor assembly from the groove. Do not use force to remove the rotor assembly.

⚠ CAUTION

Handle the rotor assembly carefully. Even small scratches or nicks can affect accuracy.

3. Use the procedure below to clean the turbine.
4. Install the rotor assembly into the turbine housing. Make sure the pointed end of the rotor assembly is inserted first. (see Figure 3) Guide the assembly into place using a smooth motion, little or no force is required.
5. Reinstall the turbine, purge the system of air, and verify accuracy before use.

Clean the Turbine

During use, the turbine should be kept full of liquid to ensure that drying does not occur inside the turbine. If drying or caking should occur, the rotor will stick or drag, affecting accuracy. To determine if the rotor is stuck or dragging, remove rotor from housing and physically turn rotor.

⚠ CAUTION

Never blow compressed air through the meter. It could damage the rotor.

1. Remove the turbine from the system following the directions above.
2. Carefully clean residue off all parts. Remove internal parts as detailed above. Note orientation carefully for correct assembly. Internal parts can be soaked for 10 to 15 minutes in compatible cleaning solutions. Use a soft brush or small probe to *carefully* remove residue from the rotor.

⚠ WARNING

Follow the liquid manufacturer's instructions for the disposal of contaminated cleaning solvents.

3. When the rotor turns freely, assemble and install it again following the instructions above.
4. Check accuracy after cleaning. See Figure 4 for bucket test method.

Figure 4

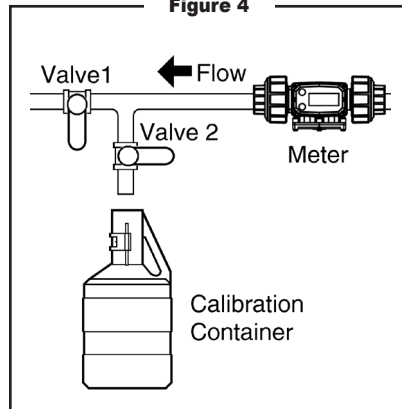

TROUBLESHOOTING

SYMPTOM	PROBABLE CAUSE	CORRECTIVE ACTION
MEASUREMENT IS NOT ACCURATE	1. Turbine operated below minimum rate.	Increase flow rate. See Specifications.
	2. Turbine partially clogged with dried liquid.	Remove turbine. Clean carefully. Make sure rotor spins freely.
	3. Turbine bearings partially clogged with dried liquid.	Remove turbine. Clean carefully. Make sure rotor spins freely.
	4. Sealant wrapped around rotor.	Remove turbine. Clear material from rotor. Make sure rotor spins freely.
	5. Installed too close to fittings.	Install correctly. See Installation Section.
	6. Improper connections to recording device.	Check all electrical connections. Reference appropriate installation instructions.
	7. Accuracy needs verification.	Complete normal accuracy verification procedures. Repeat periodically.

MODEL NUMBER CHART

Model	Normal Range GPM Water	Normal Range LPM Water	Fitting Size NPT
P05	1.2 - 12	4.54 - 45.42	1/2 inch
P10	5 - 50	18.9 - 190	1 inch

SPECIFICATIONS

All data on Models 05 and 10 determined with 1 centipoise stoddard solvent test fluid at 70° F (21° C).

Models Size	Model 05 1/2 inch	Model 10 1 inch
Linear Flow Range Gallons/minute (GPM) Litres/minute (LPM)	1.2 - 12 4.5 - 45.4	5 - 50 18.9 - 190
Maximum Flow Gallons/minute (GPM) Liters/minute (LPM)	15 56.8	75 284
Maximum Pressure Drop in 10:1 Range: PSIG bar	10.0 0.68	6.0 0.40
Frequency Range in Linear Flow Range	45 - 450 Hz	45 - 475 Hz
Fitting Type	NPT (Female) ISO (Female)	NPT (Female) ISO (Female)
Weight* Pounds Kilograms	.75 lbs. .340 kg	1.28 lbs. .580 kg
Ship Weight* Pounds Kilograms	1.13 lbs. .535 kg	1.70 lbs. .770 kg

* Computer electronics add 0.2 lbs. (0.1 kg) to total weight.

Performance	Model 05	Model 10
Linear Range:	10:1 @ ± 2% of reading	10:1 @ ± 1.5% of reading
Repeatability:	± 0.3%	± 0.3%

Pressure Rating 100 PSIG (6.9 bar)

Wetted Components

Housing:	PVDF
Journal Bearings:	Ceramic (98% Alumina)
Shaft:	Ceramic (98% Alumina)
Rotor & Supports:	PVDF
O-Ring:	FKM (Standard) PTFE (Optional - Sold Separately)

Temperature Range

These temperatures are for the turbine without computer electronics. Final operational temperature range is determined by computer electronics or accessory modules.

Operating Temperature

-20° F to +180° F (-28° C to 82° C)

Storage Temperature

-40° F to 250° F (-40° C to 121° C)

Sample Dimensions (Model 10 Shown)

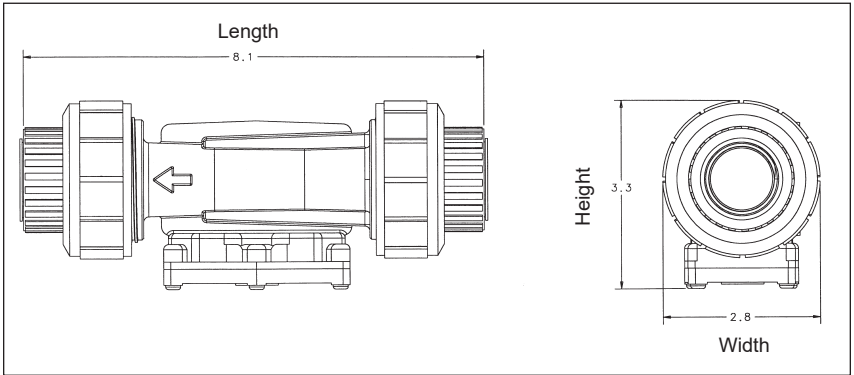

Dimensions

Models Size	Model 05 1/2 inch	Model 10 1 inch
A = Height:		
Inches	3.2 in.	3.3 in.
Centimeters	8.1 cm	8.3 cm
B = Width:		
Inches	2.1 in.	2.8 in.
Centimeters	5.3 cm	7.1 cm
C = Length:		
Inches	7.3 in.	8.1 in.
Centimeters	18.5 cm	20.5 cm

Computer electronics add 0.7 in. (1.8 cm) to height of turbine.

PARTS

Order Replacement Kits with the part numbers given here.

Part No.	Description
901002-52	Seal (Computer)
125500-7	Model 05 (1/2 inch) Rotor Assembly Replacement Kit
125500-6	Model 10 (1 inch) Rotor Assembly Replacement Kit
901003-12	O-Ring Viton Union Fitting (1/2 inch)
901003-17	O-Ring Viton Union Fitting (1 inch)
125206-1	Model 10 O-Ring Kit (two O-Rings) - Teflon
125206-2	Model 05 O-Ring Kit (two O-Rings) - Teflon

SERVICE

For warranty consideration, parts, or other service information, please contact your local distributor. If you need further assistance, call the GPI Customer Service Department C.S.T.

1-888-996-3837

To obtain prompt, efficient service, always be prepared with the following information:

1. The model number of your turbine.
2. The serial number or manufacturing date code of your turbine.
3. Specific information about part numbers and descriptions.

For warranty work always be prepared with your original sales slip or other evidence of purchase date.

Returning Parts

Please contact the factory before returning any parts. It may be possible to diagnose the trouble and identify needed parts in a telephone call. GPI can also inform you of any special handling requirements you will need to follow covering the transportation and handling of equipment which has been used to transfer hazardous or flammable liquids.

CAUTION

Do not return turbines without specific authority from the GPI Customer Service Department. Due to strict regulations governing transportation, handling, and disposal of hazardous or flammable liquids, GPI will not accept turbines for rework unless they are completely free of liquid residue.

CAUTION

Turbines not flushed before shipment can be refused and returned to the sender.

Customer Service will ask for the following at the time of service.

Model No: _____

Serial Number: _____

K-Factor: _____

Manufacturing Date: _____

Distributor Name: _____

Distributor Phone Number: _____

Note: The Manufacturing Date, K-Factor and Serial Number are etched into the Turbine Housing.

AGENCY APPROVALS TABLE

TURBINE BODY ONLY:

PVDF



TURBINE BODY WITH MOUNTED INDUSTRIAL GRADE 09 COMPUTER ELECTRONICS:



Factory Mutual Approved
Intrinsically Safe for Class I, II, III, Division 1,
All Groups



IECEEx



ATEX

NEMA
4

TURBINE BODY WITH QSB PULSE-OUT:



TURBINE BODY WITH QSB PULSE-OUT WITH Q09 DISPLAY:



**TURBINE BODY WITH QSB PULSE-OUT (OR) QSB PULSE-OUT WITH Q09 DISPLAY,
COUPLED WITH ANY QSI COMMUNICATIONS SUITE (VERSION 1, 2, OR 3):**



NOTE: When a component with Agency Approval ratings is mated to another component with the same Approval Agency ratings, the combination may gain environmental approvals. When one of the components has lesser or no Approval Agency ratings, the resultant combination assumes the ratings of the lesser rated component. If one component has no ratings, the resultant combination has no ratings.

Limited Warranty Policy

Great Plains Industries, Inc. 5252 E. 36th Street North, Wichita, KS USA 67220-3205, hereby provides a limited warranty against defects in material and workmanship on all products manufactured by Great Plains Industries, Inc. This product includes a 1 year warranty. Manufacturer's sole obligation under the foregoing warranties will be limited to either, at Manufacturer's option, replacing or repairing defective Goods (subject to limitations hereinafter provided) or refunding the purchase price for such Goods theretofore paid by the Buyer, and Buyer's exclusive remedy for breach of any such warranties will be enforcement of such obligations of Manufacturer. The warranty shall extend to the purchaser of this product and to any person to whom such product is transferred during the warranty period.

The warranty period shall begin on the date of manufacture or on the date of purchase with an original sales receipt. This warranty shall not apply if:

- A. the product has been altered or modified outside the warrantor's duly appointed representative;
- B. the product has been subjected to neglect, misuse, abuse or damage or has been installed or operated other than in accordance with the manufacturer's operating instructions.

To make a claim against this warranty, contact the GPI Customer Service Department at 316-686-7361 or 888-996-3837. Or by mail at:

Great Plains Industries, Inc.
5252 E. 36th St. North
Wichita, KS, USA 67220-3205

If you are outside North or South America contact:

Great Plains Industries – Australia
1/16 Atkinson Road,
Taren Point NSW 2229, Sydney, Australia

The company shall, notify the customer to either send the product, transportation prepaid, to the company at its office in Wichita, Kansas, or to a duly authorized service center. The company shall perform all obligations imposed on it by the terms of this warranty within 60 days of receipt of the defective product.

GREAT PLAINS INDUSTRIES, INC., EXCLUDES LIABILITY UNDER THIS WARRANTY FOR DIRECT, INDIRECT, INCIDENTAL AND CONSEQUENTIAL DAMAGES INCURRED IN THE USE OR LOSS OF USE OF THE PRODUCT WARRANTED HEREUNDER.

The company herewith expressly disclaims any warranty of merchantability or fitness for any particular purpose other than for which it was designed.

This warranty gives you specific rights and you may also have other rights which vary from U.S. state to U.S. state.

Note: In compliance with MAGNUSON MOSS CONSUMER WARRANTY ACT – Part 702 (governs the resale availability of the warranty terms).

Wichita · Sydney

GREAT PLAINS INDUSTRIES



Great Plains Industries, Inc. / 888-996-3837 / GPI.net