

# Technical Information

## Micropilot S FMR540

### Level-Radar

Level transmitter for continuous and non-contact precision level measurement

For custody transfer and inventory control applications with NMI- and PTB-approvals.



#### Application

The Micropilot S is used for highly accurate level measurement in storage tanks and can be applied in custody transfer applications. It meets the relevant requirements according to OIML R85 and API 3.1B.

Typical areas of application are:

- The Micropilot S with parabolic antenna is excellently suited for free space applications up to 40 m (131 ft).
- The Micropilot S with horn antenna is suitable for free space applications that disallow the use of a parabolic antenna due to tank/nozzle geometry.

The FMR540 with a DN200 (8") or DN250 (10") parabolic antenna offers high beam focussing of 4.4° or 3.3° respectively, and is therefore ideally suited to applications with nozzles situated close to the tank wall. The FMR540 with DN100 (4") horn antenna is designed for all small nozzle sizes.

#### Your benefits

- Accuracy: better than 1 mm (0.04 in).
- National approvals (NMI, PTB) for custody transfer.
- Easy integration into tank gauging systems via the Tank Side Monitor NRF590.
- Low-cost, easy installation via 4-wire cable with HART and 24 V DC (intrinsically safe).
- Low cost, low weight universal flanges.
- Alignment device to compensate any flange inclination.
- Easy on-site operation via menu-driven alphanumeric display.
- Easy commissioning, documentation and maintenance/diagnostics via operating software (FieldCare).
- HART communication.





## Table of Content

<b>Document information</b> .....	<b>3</b>	Integrated air purge connection .....	21
Document conventions .....	3		
<b>Function and system design</b> .....	<b>5</b>	<b>Environment</b> .....	<b>22</b>
Measuring principle .....	5	Ambient temperature range .....	22
Equipment architecture .....	6	Storage temperature .....	22
Custody transfer applications .....	7	Climate class .....	22
Integrated in tank gauging system .....	7	Degree of protection .....	22
		Vibration resistance .....	22
		Cleaning of the antenna .....	22
		Electromagnetic compatibility (EMC) .....	22
		Approvals for custody transfer applications .....	22
<b>Input</b> .....	<b>8</b>		
Measured variable .....	8	<b>Process</b> .....	<b>22</b>
Measuring range .....	8	Process temperature range .....	22
Operating frequency .....	9	Process pressure limits .....	22
		Alignment device .....	22
<b>Output</b> .....	<b>9</b>	<b>Mechanical construction</b> .....	<b>23</b>
Output signal .....	9	Design, dimensions .....	23
Signal on alarm .....	9	Weight .....	24
Load HART .....	9	Materials .....	25
Linearization .....	9	Type plate for custody transfer applications .....	27
Galvanic isolation .....	9	Endress+Hauser UNI flange .....	29
Protocol specific data .....	9		
		<b>Operability</b> .....	<b>31</b>
<b>Power supply</b> .....	<b>10</b>	Operation concept .....	31
Terminal assignment .....	10	Local operation .....	31
Supply voltage .....	11	Remote configuration .....	32
Power consumption .....	11	Display elements .....	34
Current consumption .....	11	Operating elements .....	35
Electrical connection .....	12		
Cable entry .....	12	<b>Certificates and approvals</b> .....	<b>36</b>
Residual ripple HART .....	12	CE approval .....	36
Max noise HART .....	12	C-Tick symbol .....	36
Overvoltage protection .....	12	Ex approval .....	36
Power supply .....	12	Overfill prevention .....	36
Highly accurate measurement .....	12	RF approvals .....	36
		CRN approvals .....	36
		Approvals for custody transfer applications .....	36
		External standards and guidelines .....	36
<b>Performance characteristics</b> .....	<b>13</b>		
Reference operating conditions .....	13	<b>Ordering information</b> .....	<b>37</b>
Maximum measured error .....	13	Ordering information .....	37
Resolution .....	13	Scope of delivery .....	37
Settling time .....	13		
Hysteresis .....	13	<b>Accessories</b> .....	<b>37</b>
Non-repeatability .....	13	Device-specific accessories .....	37
Reaction time .....	13	Communication-specific accessories .....	38
Long-term drift .....	13	Service-specific accessories .....	38
Influence of ambient temperature .....	13		
Proof of accuracy of custody transfer versions .....	13	<b>Documentation</b> .....	<b>39</b>
Maximum fill speed .....	13	Standard documentation .....	39
Software reliability .....	13	Supplementary device-dependent documentation .....	39
Inventory control versions .....	14	Safety Instructions .....	39
<b>Installation</b> .....	<b>15</b>		
Installation conditions .....	15		
Installation instructions .....	15		
Measuring conditions .....	16		
Installation on tank .....	17		
Alignment device .....	19		
Beam angle .....	20		







## Document information

### Document conventions





### Safety symbols



Symbols	Meaning
 A0011189-EN	<b>DANGER!</b> This symbol alerts you to a dangerous situation. Failure to avoid this situation will result in serious or fatal injury.
 A0011190-EN	<b>WARNING!</b> This symbol alerts you to a dangerous situation. Failure to avoid this situation can result in serious or fatal injury.
 A0011191-EN	<b>CAUTION!</b> This symbol alerts you to a dangerous situation. Failure to avoid this situation can result in minor or medium injury.
 A0011192-EN	<b>NOTICE!</b> This symbol contains information on procedures and other facts which do not result in personal injury.

### Electrical symbols



Symbols	Meaning
 A0018335	<b>Direct current</b> A terminal at which DC voltage is present or through which direct current flows.
 A0018336	<b>Alternating current</b> A terminal at which AC voltage is present or through which alternating current flows.
 A0018337	<b>Direct current and alternating current</b> <ul style="list-style-type: none"> <li>▪ A terminal at which AC voltage or DC voltage is present.</li> <li>▪ A terminal through which alternating current or direct current flows.</li> </ul>
 A0018338	<b>Ground connection</b> A grounded terminal which, from the operator's point of view, is grounded via a grounding system.
 A0018339	<b>Protective ground connection</b> A terminal that must be connected to ground before establishing other connections.
 A0011201	<b>Equipotential connection</b> A connection that must be made with the plant grounding system. This could, for example, be a potential matching line or a star-shaped grounding system, depending on national or company codes of practice.

### Symbols for certain types of information

Symbols	Meaning
 A0011182	<b>Allowed</b> Indicates procedures, processes or actions that are allowed.
 A0011183	<b>Preferred</b> Indicates procedures, processes or actions that are preferred.
 A0011184	<b>Forbidden</b> Indicates procedures, processes or actions that are forbidden.
 A0011193	<b>Tip</b> Indicates additional information.
 A0015483	<b>Reference to documentation</b> Refers to the relevant device documentation.

 <small>A0015484</small>	<b>Reference to page</b> Refers to the relevant page number.
 <small>A0015486</small>	<b>Reference to diagrams</b> Refers to the relevant graphic number and page number.
1. , 2. , ...	Series of steps
 <small>A0015488</small>	<b>Help in the event of a problem</b>

### Symbols in graphics

Symbols	Meaning
1, 2, 3, 4, ...	Numbering for main positions
1. , 2. , ...	Series of steps
A, B, C, D, ...	Views
A-A, B-B, ...	Sections
 <small>A0011187</small>	<b>Hazardous area</b> Indicates a hazardous area.
 <small>A0011188</small>	Safe area (non-hazardous area) Indicates a non-hazardous area.

## Function and system design

### Measuring principle

The Micropilot is a "downward-looking" measuring system, operating based on the time-of-flight method. It measures the distance from the reference point (process connection) to the product surface. Radar impulses are emitted by an antenna, reflected off the product surface and received again by the radar system.

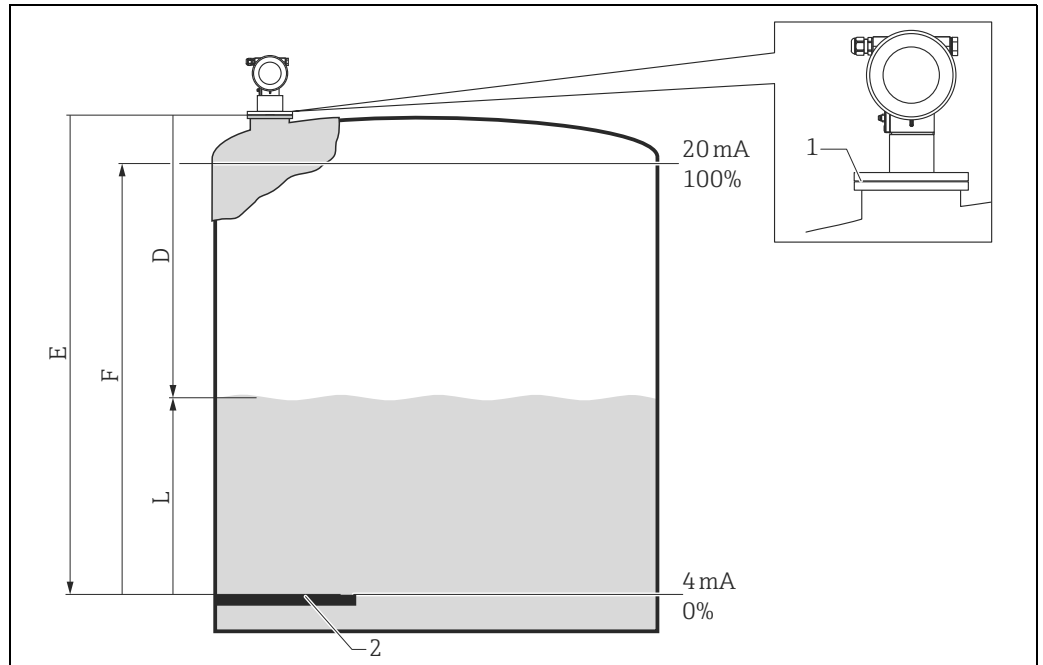

- 1 GRH reference point of measurement (bottom edge of flange or threaded connection)  
 2 Level zero point (gauge reference plate)

- E Empty calibration (= zero point)  
 F Full calibration (= span)  
 D Distance measured  
 L Level ( $L = E - D$ )

### Input

The reflected radar impulses are received by the antenna and transmitted into the electronics. A microprocessor evaluates the signal and identifies the level echo caused by the reflection of the radar impulse at the product surface.

The unambiguous signal identification is accomplished by the PulseMaster® software, based on many years of experience with time-of-flight technology. The mm-accuracy of the Micropilot S could be achieved with the patented algorithms of the PulseMaster® software.

The distance "D" to the product surface is proportional to the time of flight "t" of the impulse:

$$D = c \cdot t / 2,$$

with "c" being the speed of light.

Based on the known empty distance "E", the level "L" is calculated:

$$L = E - D$$

Reference point for "E" is the lower surface of the process connection. For highly precise level measurements, it is of crucial importance to have a stable mounting position (GRH) of the radar gauge or to compensate for the effects of tank movements during filling and emptying cycles. This can be done by either using the dip chart integrated in the Micropilot S FMR53x/540 or by using the compensation methods integrated into the Tank Side Monitor NRF590. The stability of the reference point for the measurement (GRH) has a decisive influence on the accuracy of the measurement! The Micropilot is equipped with functions to suppress interference echoes. The user can activate these functions. They ensure that interference echoes (e.g. from edges and weld seams) are not interpreted as level echo.

## Output

The Micropilot is commissioned by entering an empty distance "E" (= zero), a full distance "F" (= span) and an application parameter. The application parameter automatically adapts the device to the process conditions. The data points "E" and "F" correspond with 4 mA and 20 mA for devices with current output. They correspond with 0 % and 100 % for digital outputs and the display module. For inventory control or custody transfer applications, the measurement should always be transferred via digital communication (HART).

A linearization with max. 32 points, based on a table entered either manually or semi-automatically, can be activated locally or remotely. This function allows, for example, measurement in engineering units and provides a linear output signal for spherical and horizontal cylindrical tanks, or tanks with a conical outlet.

## Equipment architecture

### Stand-alone

The device has a 4-20 mA output with HART protocol.

The complete measuring system consists of:

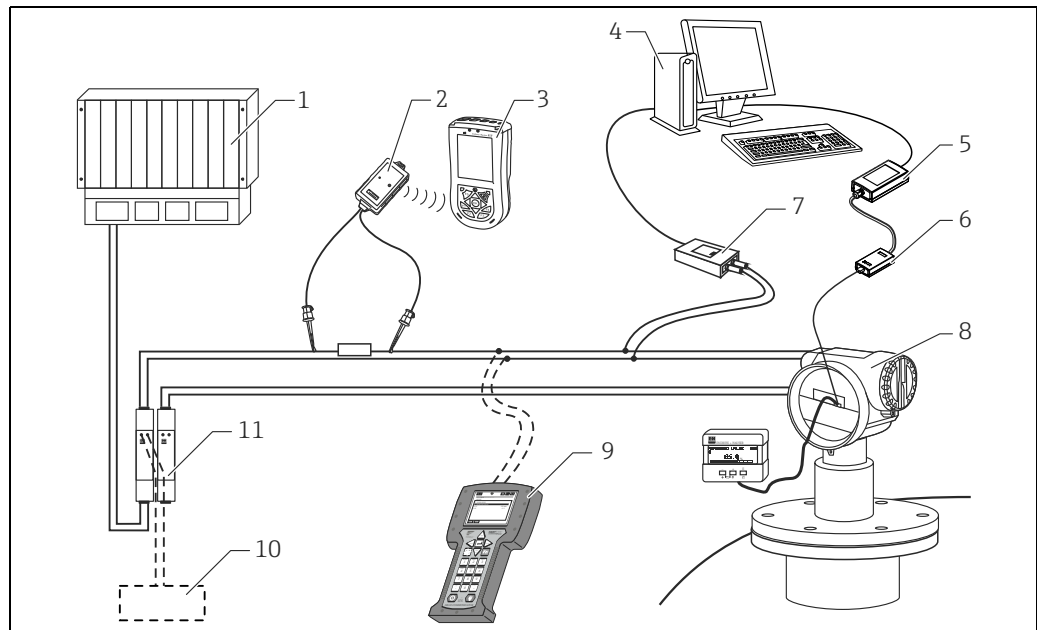

- 1 PLC (programmable logic controller)
- 2 VIATOR Bluetooth modem with connecting cable
- 3 Field Xpert
- 4 Computer with operating tool (e.g. FieldCare)
- 5 Commubox FXA291
- 6 ToF adapter FXA291
- 7 Commubox FXA195 (USB)
- 8 Micropilot with display module
- 9 Field Communicator 475
- 10 FXA195 or Field Communicator 475
- 11 Transmitter power supply unit RN221N (with communication resistor)

### Local configuration

- with display and operating module VU331,
- with a Personal Computer, FXA291 with ToF Adapter FXA291 (USB) and the operating software "FieldCare". FieldCare is a graphical operating software for devices from Endress+Hauser (radar, ultrasonic, guided micro-impulse). It assists with commissioning, securing data, signal analysis and documentation of the measuring point.

### Remote configuration

- with Field Communicator 475
- with Field Xpert
- with a personal computer, Commubox FXA195 and "FieldCare" operating software

### Remote operation

With a Personal Computer, NRF590 (Tank Side Monitor) and the inventory management software.

### Integration into the Asset Management System

The HART interface allows the integration into the AMS® (Asset Management System) from Emerson.

#### Custody transfer applications

The Micropilot S is suitable for custody transfer and inventory control applications. The on-site testing has to be done in compliance with the applicable regulatory standards. The Micropilot S can be sealed after successful on-site calibration to be protected against any access to the electronics compartment and any changes of software settings. If the Micropilot S is used for custody transfer or inventory control, any temperature influence on the tank shell height can be compensated for using the Tank Side Monitor. In addition, the vertical movement of the gauge reference point due to the hydrostatic tank deformation can be compensated in the Tank Side Monitor. A Tank Side Monitor can provide 24 V DC for a Micropilot S. The Tank Side Monitor can communicate with up to 6 devices via HART Multidrop.

#### Integrated in tank gauging system

The Endress+Hauser Tank Side Monitor NRF590 provides integrated communications for sites with multiple tanks, each with one or more sensors on the tank, such as radar, spot or average temperature, capacitive probe for water detection and/or pressure sensors. Multiple protocols out of the Tank Side Monitor guarantee connectivity to nearly any of the existing industry standard tank gauging protocols. Optional connectivity for 4-20 mA sensors, digital I/O and analog outputs facilitate full integration of all sensors at the tank. Use of the proven concept of the intrinsically safe HART bus for all on-tank sensors yields extremely low wiring costs, while at the same time providing maximum safety, reliability and data availability.

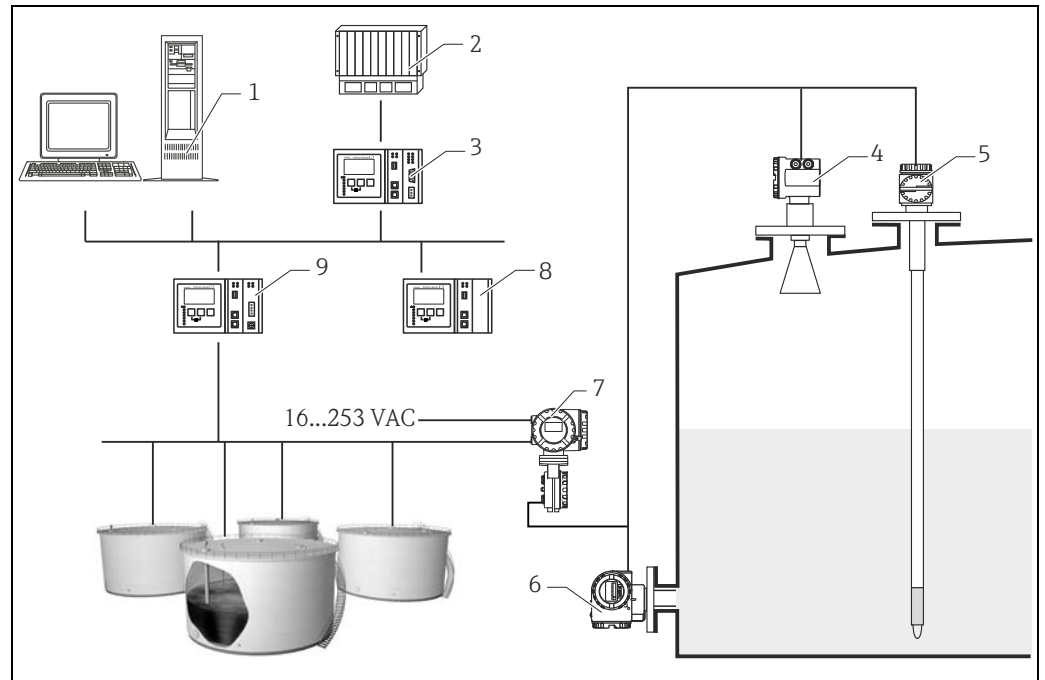

- 1 Tankvision workstation
- 2 Process control system
- 3 Host Link
- 4 Micropilot S
- 5 Prothermo
- 6 Pressure transmitter
- 7 Tank Side Monitor
- 8 Data Concentrator
- 9 Tankvision Tank Scanner NXA820

A0020697

## Input

### Measured variable

The measured variable is the distance between the reference point (GRH, refer to fig., → 5) and a reflective surface (i.e. medium surface). The measured value as well as all parameters can be displayed in either metrical SI units or US/UK units (inch, ft, ...).

The level is calculated based on the tank height entered. The level can be converted into other units (volume, mass) by means of a linearization. To compensate for non-linear effects such as movement of the tank roof, a correction table (dip chart) can also be entered.

### Measuring range

The usable measuring range depends on the size of the antenna, the reflectivity of the medium, the mounting location and possible interference reflections.

To achieve an optimised signal strength it is recommended to use an antenna with as large as possible diameter (DN200 (8") or DN250 (10") parabolic antenna).

The following tables describe the groups of media as well as the achievable measuring range as a function of application and media group. If the dielectric constant of the medium is unknown, we recommend that you assume media group **B**, in order to ensure a reliable measurement.

Media group	DC ( $\epsilon_r$ )	Examples
<b>A1</b>	1.4 to 1.6	propane, butane
<b>A2</b>	1.6 to 1.9	Non-conducting liquids, e.g. liquefied gas (LPG). For more information, please contact your Endress+Hauser sales center.
<b>B</b>	1.9 to 4	Non-conducting liquids, e.g. gasoline, oil, toluene, white products, crude oil, bitumen, asphalt ...
<b>C</b>	4...10	e.g. concentrated acids, organic solvents, esters, aniline, alcohol, acetone, ...
<b>D</b>	> 10	Conducting liquids, e.g. aqueous solutions, diluted acids and alkalies

### Measuring range depending on sensor type and media group

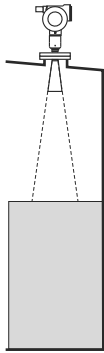
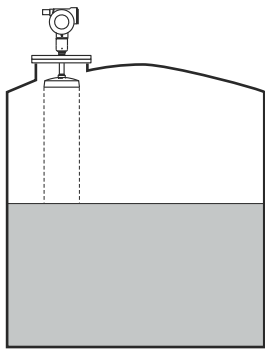
Media group		Horn antenna without sensor extension	Parabolic antenna without sensor extension
			
		Measuring range <sup>1)</sup>	Measuring range <sup>1)</sup>
<b>A1</b>	DC ( $\epsilon_r$ ) = 1.4 to 1.6	Please contact your Endress+Hauser sales center.	
<b>A2</b>	DC ( $\epsilon_r$ ) = 1.6 to 1.9	0.6 to 20 m (2 to 66 ft)	0.6 to 40 m (2 to 131 ft)
<b>B</b>	DC ( $\epsilon_r$ ) = 1.9 to 4		
<b>C</b>	DC ( $\epsilon_r$ ) = 4 to 10		
<b>D</b>	DC ( $\epsilon_r$ ) > 10	0.6 to 30 m (2 to 98 ft)	
<b>Max. measuring range with custody transfer approval</b>		NMi: 23 m (75 ft) PTB: 23 (75 ft)	NMi: 26 m (85 ft) PTB: 30 m (98 ft)

1) All values are based on reference conditions.



For stilling well applications Micropilot S FMR532 is recommended (see TI01122F/00/EN).



**Operating frequency** K band (~ 26 GHz)  
Up to 8 Micropilot devices can be installed in the same tank, as the transmitter pulses are statistically coded.

## Output

**Output signal** 4-20 mA (invertible) with HART protocol (e.g. for multi-drop connection to Tank Side Monitor NRF590): This version can be operated using the PC and the operating software FieldCare. The device supports both point-to-point and multidrop operation. For measurements with mm precision, the measured value must be transmitted via HART protocol to ensure the necessary resolution.

Order code in Product Configurator under "Output; Operation" signal: Version A (4-line display VU331, envelope curve display on site)

**Signal on alarm** Error information can be accessed via the following interfaces:

- Local display:
  - Error symbol
  - Plain text display
  - LED's: red LED continuously on = alarm, red LED flashes = warning
- Current output
- Digital interface

**Load HART** Minimum load for HART communication: 250 Ω

**Linearization** The linearization function of the Micropilot S allows the conversion of the measured value into any unit of length or volume. Linearization tables for calculating the volume in cylindrical tanks are pre-programmed. Other tables of up to 32 value pairs can be entered manually or semi-automatically.

**Galvanic isolation** 500 V towards

- power supply and ground
- power supply and signal

**Protocol specific data**

**HART**

Manufacturer ID	000011 hex
Device Type Code	001F hex
Transmitter-specific revision	01 hex
Device Revision	1 (for SW 01.01.00) 2 (for SW 01.01.02)
Features supported	<ul style="list-style-type: none"> <li>■ Burst mode</li> <li>■ Additional Transmitter Status</li> </ul>
DD-Files	Actual information and files can be found: <ul style="list-style-type: none"> <li>■ <a href="http://www.endress.com">www.endress.com</a></li> <li>■ <a href="http://www.hartcomm.org">www.hartcomm.org</a></li> </ul>
Load HART	Min. 250 Ω
Device variables	Primary value: level or volume <sup>1)</sup>

1) depending on configuration

## Power supply

### Terminal assignment

#### 4-20 mA with HART

The 4-wire cable is connected to the screw terminals (wire diameters 0.5 to 2.5 mm<sup>2</sup> [20 to 14 AWG]) in the terminal compartment. Use 4-wire twisted pair cable with screen for the connection. Protective circuitry against reverse polarity, RFI, and over-voltage peaks is built into the device (TI00241F/00/EN, "basics for EMC-tests").

#### Connection to Tank Side Monitor NRF590

The Micropilot S may be connected, together with other devices in a hazardous area, to a Tank Side Monitor. In this case, it is recommended that the shielding on the cables be grounded centrally at the Tank Side Monitor and that all devices be connected to the same potential matching line (PML). If, for functional reasons, a capacitive coupling is required between the local ground and the shield (multiple grounding), ceramic capacitors with a minimum dielectric strength of 1500 Veff must be used. The overall capacity of 10 nF must not be exceeded in this case. The FISCO model provides information on grounding intrinsically safe, interconnected devices.

If it is not possible to lay a grounding cable between the NRF590 and the Micropilot S, it is possible to ground on one side at the NRF590. In this case, it is essential that the cable shield on the Micropilot S be grounded using a ceramic capacitor with a maximum capacitance of 10 nF and a minimum isolation voltage of 1500 V.

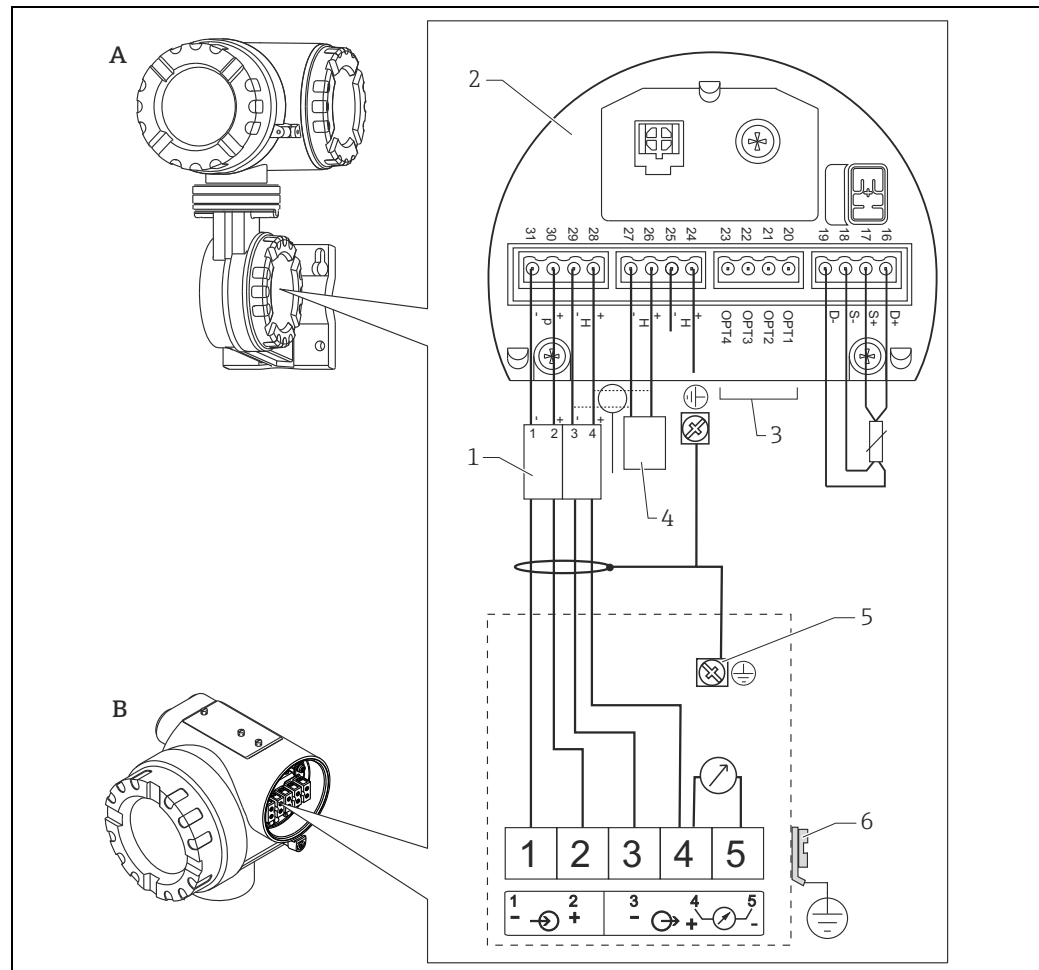

- A Tank Side Monitor NRF590
- B Micropilot S
- 1 For Micropilot S only
- 2 Intrinsically safe terminal strip
- 3 Shield, grounded on one side at Tank Side Monitor NRF590
- 4 HART sensor
- 5 Shielding cable
- 6 PML (potential matching line)

A0020823

Connection as a stand-alone device

The Micropilot S located in a hazardous area is connected as a stand-alone device to a power supply unit and transmitter located outside the hazardous area. In this case, it is recommended that the shielding directly on the Micropilot be connected to the housing ground; the Micropilot S and the supply unit are connected to the same potential matching line (PML).

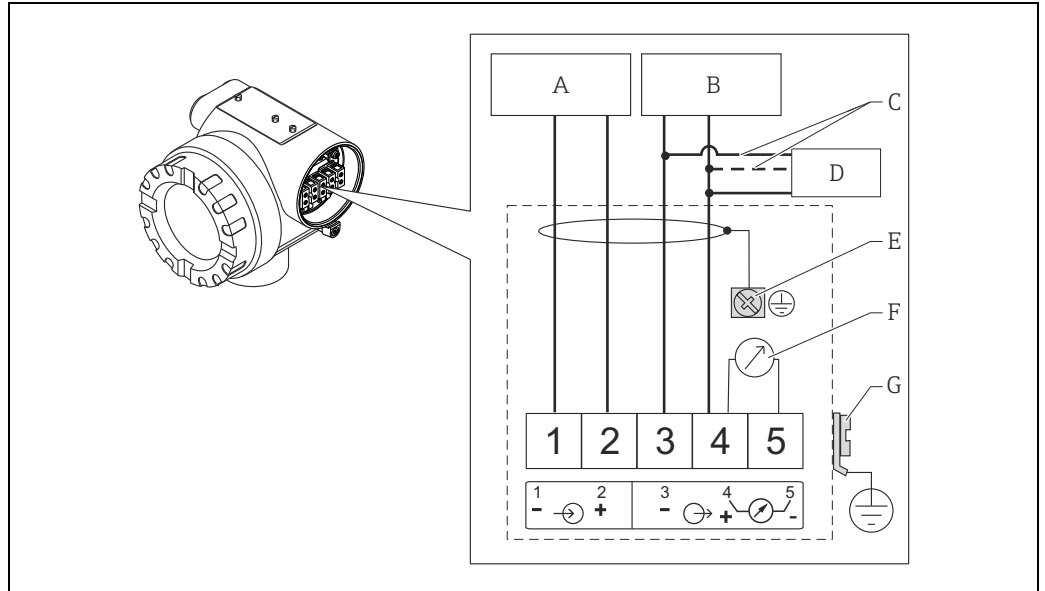

- A Power supply 24 VDC; provided by a supply unit
- B Signal 24 VDC; provided by a supply unit
- C Alternative connection
- D CommuBox FXA195, Field Communicator
- E Shielding cable
- F Test socket; Output current
- G PML (potential matching line)

A0020824

Supply voltage

DC voltage: see the following table

Communication		Terminal voltage	minimum	maximum
Power supply	Standard	U (20 mA) =	16 V	36 V
	Ex	U (20 mA) =	16 V	30 V
Signal	Ex	U (4 mA) =	11.5 V	30 V
		U (20 mA) =	11.5 V	30 V

Power consumption

- max. 400 mW at 16 V
- max. 600 mW at 24 V
- max. 750 mW at 30 V
- Non-Ex: max. 900 mW at 36 V

Current consumption

Max. 25 mA (55 mA inrush current).

**Electrical connection**

The electronics and current output are galvanically isolated from the antenna circuit.

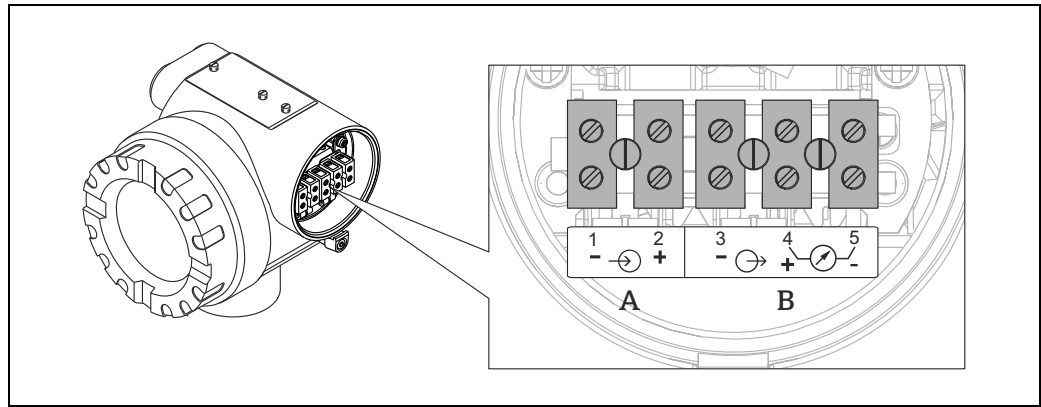

A Power supply  
B Voltage

**Cable entry**

Designation	Version*
Thread M20 Plastics M20x1.5 for cable $\phi$ 5 to 10 mm (0.2 to 0.39 in)	1
Cable gland M20	2
Thread for cable entry G 1/2"	3
Thread for cable entry NPT 1/2"	4

\* Order code in Product Configurator (→ [37](#))

**Residual ripple HART**

47 to 125 Hz:  $U_{pp} = 200$  mV

**Max noise HART**

500 Hz to 10 kHz :  $U_{eff} = 19$  mV (at 500  $\Omega$ )

**Overvoltage protection**

- The level transmitter Micropilot S is equipped with an internal overvoltage protector (600 Vrms surge arrester) according to EN/IEC 60079-14 or EN/IEC 60060-1 (impulse current test 8/20 s,  $\hat{I} = 10$  kA, 10 pulses). Additionally, the device is protected by a galvanic insulation of 500 Vrms between the power supply and the (HART) current output. Connect the metallic housing of the Micropilot S to the tank wall or shield directly using an electrically conductive lead to ensure reliable potential matching.
- Installation with additional overvoltage protection HAW560Z/HAW562Z (see XA00081F, "Safety instructions for electrical apparatus certified for use in explosion-hazardous areas").
  - Connect the external overvoltage protector and the Micropilot S transmitter to the local potential matching system.
  - Potentials shall be equalised both inside and outside the explosion hazardous area.
  - The length of the cable connecting the overvoltage protection and the Micropilot S level transmitter must not exceed 1 m (3.3 ft).
  - The cable must be protected e.g. routed through a metal tube.



**Power supply**



- As a stand-alone version, power supply for example via two RN221N from Endress+Hauser.
- Integrated in tank gauging systems via Endress+Hauser Tank Side Monitor NRF590 (recommended use).

**Highly accurate measurement**

For highly accurate measurements the measured variable must be transmitted using HART protocol to ensure the necessary resolution.

## Performance characteristics

 For accuracy data for devices suitable for custody transfer measurement in accordance with OIML R85, see Ambient temperature range. →  22.

<b>Reference operating conditions</b>	<p><b>According to OIML R85:</b></p> <ul style="list-style-type: none"> <li>■ Temperature = -25 °C to +55 °C (-13 °F to +131 °F)</li> <li>■ Atmospheric pressure</li> <li>■ Relative humidity (air) = 60 % ±15 %</li> <li>■ Medium properties: e.g. medium with good reflectivity and calm surface.</li> <li>■ Tank diameter: signal beam hits the tank wall only at one side.</li> <li>■ No major interference reflections inside the signal beam.</li> </ul>
<b>Maximum measured error</b>	<p>Absolute accuracy better than ±1 mm (0.04 in) (better than 1/16")</p> <p> The Micropilot S versions for free space applications have a typical accuracy of &lt;1.0 mm (2 sigma value). Depending on national calibration regulations, the permitted errors after the device has been installed on the tank are ±3 mm (0.12 in), (OIML, API)...</p>
<b>Resolution</b>	Digital 0.1 mm / analogue: 0.03 % of measuring range
<b>Settling time</b>	Typical: 15 sec
<b>Hysteresis</b>	0.1 mm
<b>Non-repeatability</b>	0.1 mm
<b>Reaction time</b>	The reaction time depends on the parameter settings (min. 1 s). In case of fast level changes, the device needs the reaction time to indicate the new value.
<b>Long-term drift</b>	The long-term drift is within the specified accuracy.
<b>Influence of ambient temperature</b>	<p>Current output (additional error, in reference to the span of 16 mA):</p> <ul style="list-style-type: none"> <li>■ <b>Zero point (4 mA)</b> average <math>T_K</math>: 0.025 %/10 K, max. 0.291 % over the entire temperature range -40 °C to +80 °C (-40 °F to 176 °F)</li> <li>■ <b>Span (20 mA)</b> average <math>T_K</math>: 0.07 %/10 K, max. 0.824 % over the entire temperature range -40 °C to +80 °C (-40 °F to 176 °F)</li> </ul>
<b>Proof of accuracy of custody transfer versions</b>	The degree of accuracy is confirmed by a calibration certificate that records the absolute and relative error at 10 measuring points during the final test. A Laser Interferometer (Jenaer Messtechnik ZLM 500) with an absolute accuracy of 0.1 mm is used as a reference for free space measurements. In addition, certificates confirming initial verification are available on request for all radar devices in the FMR540 series.
<b>Maximum fill speed</b>	By the first pass trough of measuring range: 100 mm/min., thereafter unlimited.
<b>Software reliability</b>	<p>The software used in the radar devices FMR540 fulfills the requirements of OIML R85. This particularly includes:</p> <ul style="list-style-type: none"> <li>■ Cyclical testing of data consistency</li> <li>■ Non-volatile memory</li> <li>■ Segmented data storage</li> </ul> <p>The radar devices Micropilot S continuously monitor the compliance with accuracy requirements for custody transfer measurements according to OIML R85. If the accuracy cannot be maintained, a specific alarm is generated on the local display and via the digital communication (→  34).</p>

**Inventory control versions**

All device versions can be delivered as "Inventory Control" versions with reduced accuracy (3 mm [0.12 in]) under reference conditions. **No** calibration certificate or type approval is supplied with these versions. The "Inventory Control" versions are selected by specifying Version "R - Not selected; Inventory control version" in the Product Configurator under "Weight + measure approval".

## Installation

### Installation conditions

- Recommended distance (1) from tank wall to center of nozzle:  
minimum as specified in table, "Beam angle",  
→ 20.
- Not in the centre (3), interference can cause signal loss.
- Not above the fill stream (4).
- It is recommended to use a weather protection cover (2) in order to protect the transmitter from direct sun or rain.  
Assembly and disassembly is simply done by means of a tension clamp ("Accessories",  
→ 37).

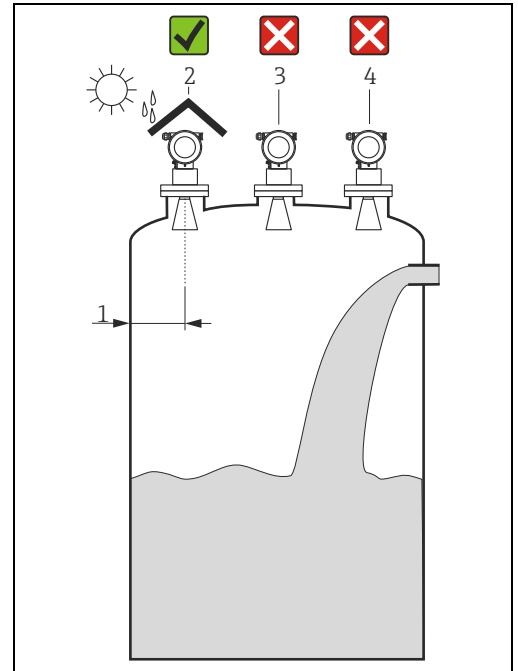

A0021541

### Tank installations

- Avoid any installations (1), like limit switches, temperature sensors, etc., inside the signal beam ("Beam angle", → 20).
- It is essential that HiHi alarm is below the blocking distance (BD) and the safety distance (SD).
- Symmetrical installations (2), e.g. vacuum rings, heating coils, baffles, etc., can also interfere with the measurement.
- Metallic screens (3) mounted at an angle disperse the radar signals and can therefore reduce interference echoes.

For more information, please contact your Endress+Hauser sales center.

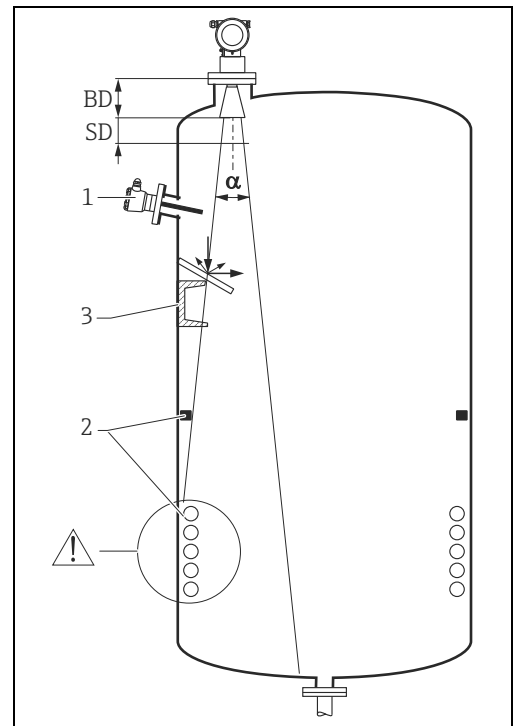

A0020826

### Installation instructions

With a DN100 (4") **horn**, this antenna is suitable for free space applications up to a measuring distance of 20 m/30 m (66 ft/98 ft), (depending on dielectric constant). With the narrow beam angle (8 deg), this horn antenna is suitable for closer to tank wall application ("Beam angle", → 20). When installing, it is essential that the horn extends below the nozzle ("Installation on tank", → 17). If condensation occurs, try using the parabolic antenna, or contact your Endress+Hauser sales center. The **parabolic antenna** offers the smallest beam angle (3.3 deg) for free space applications. It also offers the longest possible measuring distance of 40 m (131 ft) (dielectric constant > 1.8). It is ideal for applications close to the tank walls.

**Optimisation options**

- Antenna size: the bigger the antenna, the smaller the beam angle, the less interference echoes.
- Mapping: the measurement can be optimized by means of electronic suppression of interference echoes.
- Antenna alignment: "**Optimum mounting position**", → 17.
- Stilling well: a stilling well can always be used to avoid interference. The FMR532 with planar antenna is recommended for stilling wells with a diameter DN150 (6") and larger.

**Measuring conditions**

- Tank diameter and height should be at least dimensioned such that a reflection of the radar signal on both sides of the tank can be avoided.
- In case of media with a low dielectric constant (groups A and B), the tank bottom can be visible through the medium at low levels (low height C). Reduced accuracy has to be expected in this range. If this is not acceptable, we recommend positioning the zero point at a distance C (see Fig.) above the tank bottom in these applications.
- In principle, it is possible to measure up to the tip of the antenna with the FMR540. However, due to corrosion and build-up, the end of the measuring range should not be any closer than A (see Fig.).

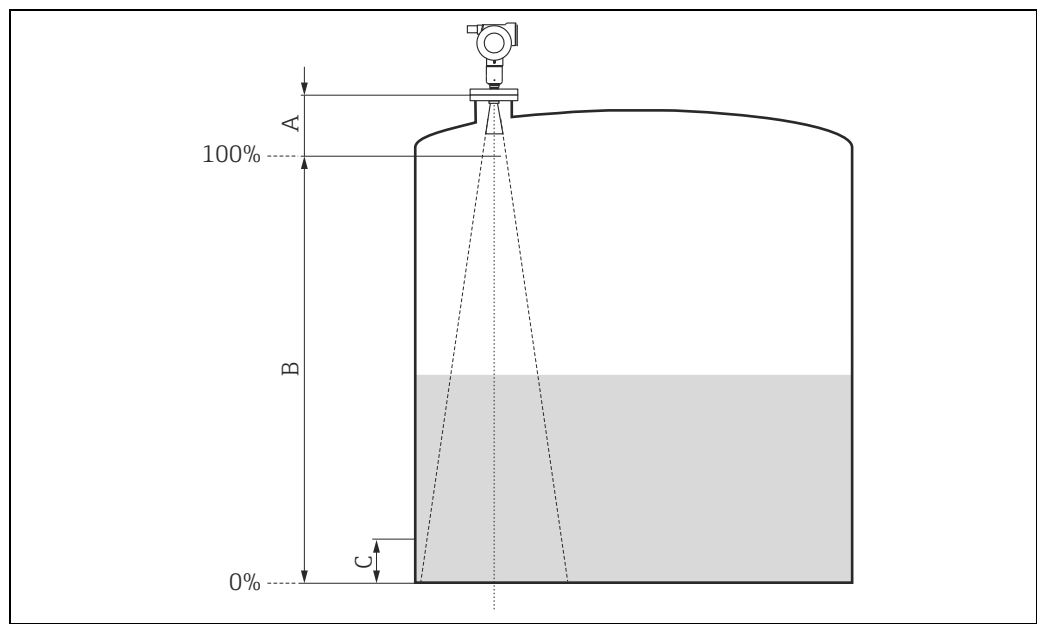

A0020737

1)	A [mm (in)]			B [m (ft)]	C [mm (in)]
	4" Horn antenna	8" Parabolic antenna	10" Parabolic antenna	All antennas	
FMR540 (without extension)	870 (34.3)	502 (19.8)	530 (20.9)	>0.5 (1.6)	>300 (11.8)
FMR540 with Extension 150 mm (5.9 in)	1020 (40.2)	652 (25.7)	680 (26.8)	>0.5 (1.6)	>300 (11.8)
FMR540 with Extension 250 mm (9.8 in)	1120 (44.1)	752 (29.6)	780 (30.7)	>0.5 (1.6)	>300 (11.8)
FMR540 with Extension 450 mm (18 in)	1320 (52.0)	952 (37.5)	980 (38.6)	>0.5 (1.6)	>300 (11.8)

1) All values are based on reference conditions.

**Behaviour if measuring range is exceeded**

The behaviour in case of the measuring range being exceeded can be freely set:  
 The default setting is a current of 22 mA and the generation of a digital warning (E651).



Installation on tank

Optimum mounting position

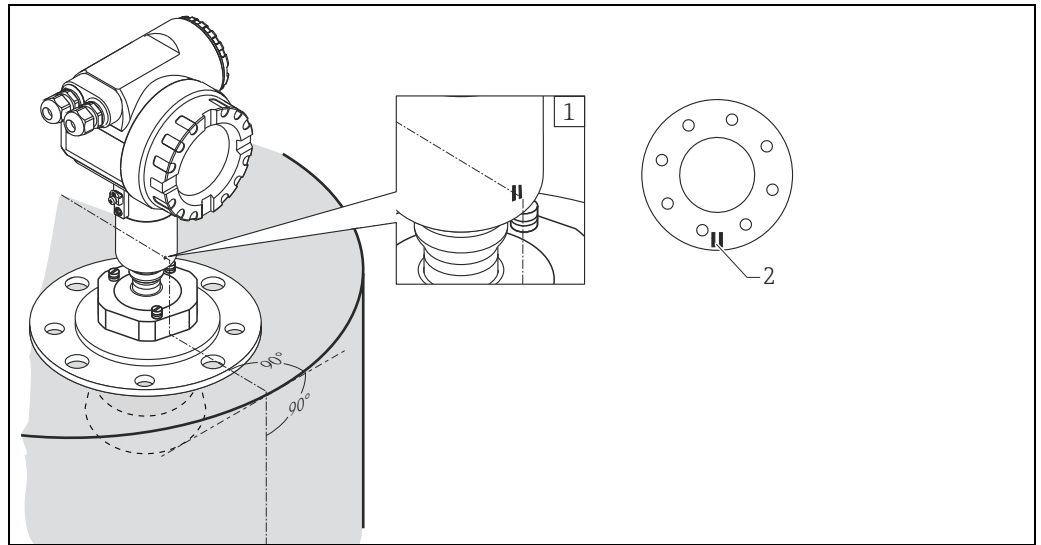

- 1 Marking on sensor
- 2 Marking on flange

A0020810

Standard installation with horn antenna

- Follow installation instructions (→ 15).
- Marker must be aligned towards tank wall. The marker is located clearly visible on the sensor neck or the flange.
- After mounting, the housing can be turned 350° in order to simplify access to the display and the terminal compartment.
- Adjust vertical sensor alignment in case the flange is not parallel to the face is medium surface.
- The horn antenna should protrude from the nozzle. If necessary, choose version with antenna extension (→ 23).  
For applications with higher nozzles, please contact your Endress+Hauser sales center.
- The horn antenna should be installed with 3° inclination towards the tank center. To avoid interference reflections or for optimum alignment within the tank, the FMR540 with optional alignment device can be swiveled by 15° in all directions.

For more information, please see Operating Instructions KA00274F/00/EN.

If you have any questions regarding commissioning, please contact your Endress+Hauser sales center.

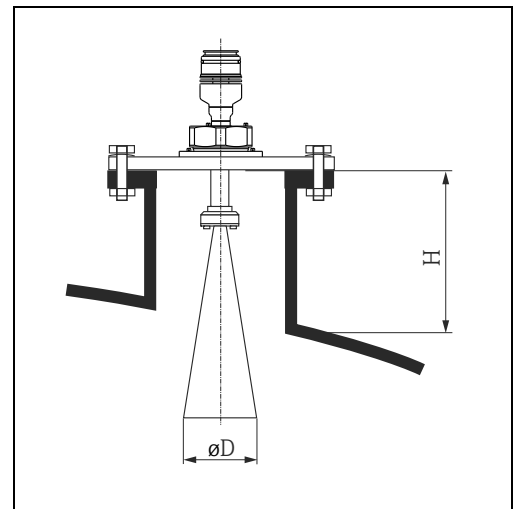

A0020809

Antenna size	100 mm (4")
D (mm[in])	95 (3.74)
H (mm [in]) (without antenna extension)	< 430 (16.9)

### Standard installation with parabolic antenna

- Follow installation instructions (→  15).
- Marker is aligned towards tank wall. The marker is located clearly visible on the sensor neck or the flange.
- After mounting, the housing can be turned 350° in order to simplify access to the display and the terminal compartment.
- Ideally, the parabolic antenna should extend completely out of the nozzle (A).  
Particularly when using the alignment device, please ensure that the parabolic reflector is protruding from the nozzle/roof so as not to inhibit alignment.

 For applications with higher nozzles, install the parabolic antenna completely in the nozzle (B), including RF waveguide.

- The parabolic antenna should be installed vertically. To avoid interference reflections or for optimum alignment within the tank, the FMR540 with optional alignment device can be swiveled by 15° in all directions. For more information, please see Operating Instructions KA00274F/00/EN.  
If you have any questions regarding commissioning, please contact your Endress+Hauser sales center.

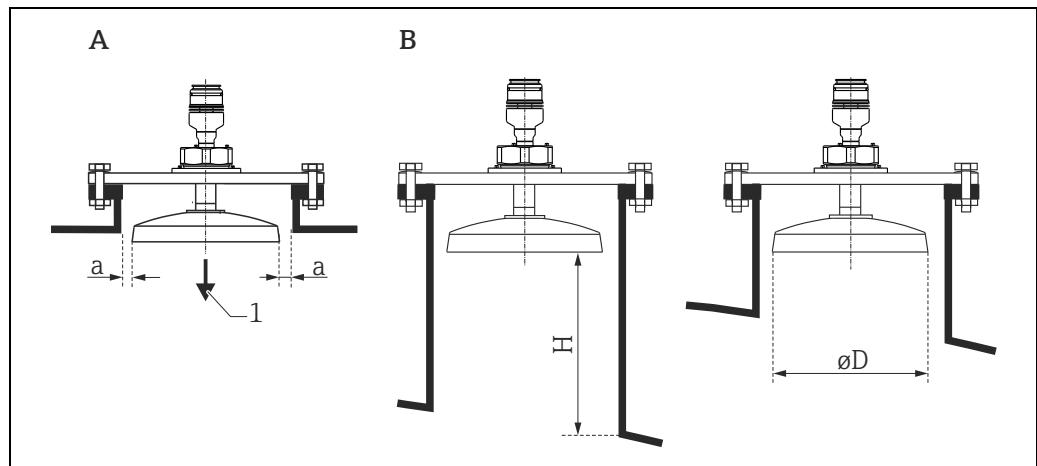

A0020806

- A Antenna is extending out of the nozzle  
 B Antenna installation in the nozzle  
 1 Installation perpendicular to surface of medium  
 a Observe distance

Antenna size	200 mm (8")	250 mm (10")
D (mm [in])	173 (6.81)	236 (9.29)
H (mm [in]) (without antenna extension)	< 200 (7.87)	< 200 (7.87)

**Alignment device****Optimum mounting position**

The Micropilot S should be installed at right angles to the surface of the medium for optimum measuring performance of  $\pm 1$  mm (0.04 in). Using the alignment device it is possible to tilt the antenna axis by up to  $15^\circ$  in all directions. The alignment device is used for the optimum alignment of the radar beam to the liquid surface.

The Sensor should be positioned vertical to the liquid surface in inclination of  $0^\circ$  for Parabolic Antenna and up to  $3^\circ$  for Horn Antenna.

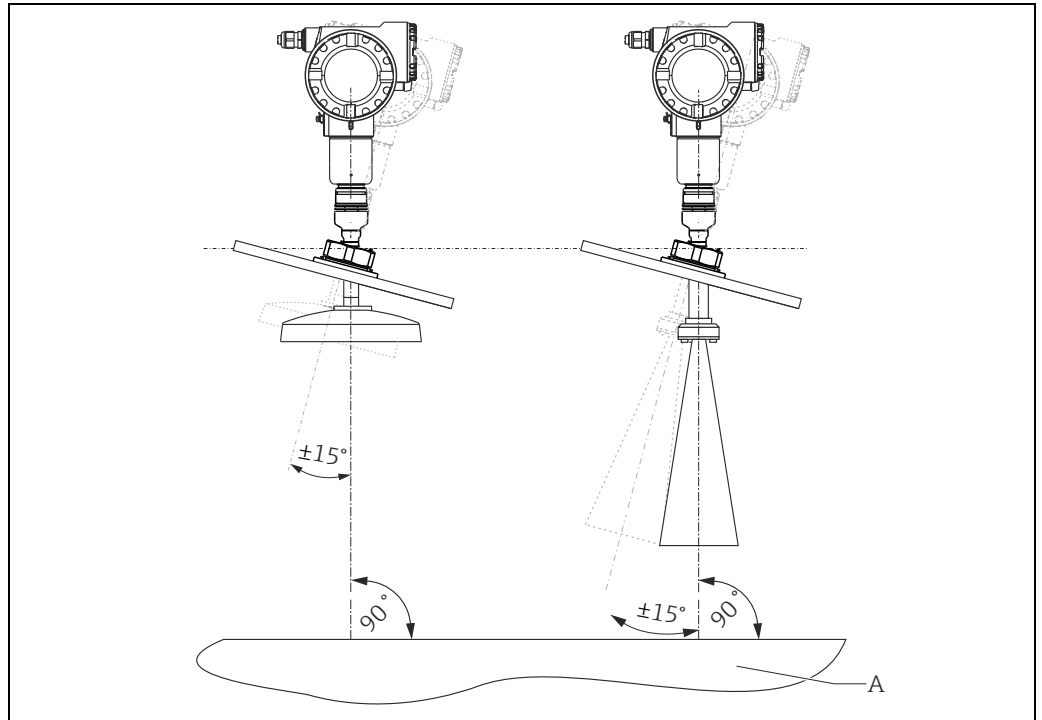

A Medium

A0020807

To align the antenna as precisely as possible, it is recommended to use the Level Tool, which is available as an accessory. For more information, please see Operating Instructions KA00274F/00/EN. In case of custody Application, the screws must be locked with wires.

**Beam angle**

The beam angle is defined as the angle  $\alpha$  where the energy density of the radar waves reaches half the value of the maximum energy density (3dB-width). Microwaves are also emitted outside the signal beam and can be reflected off interfering installations. The beam diameter  $W$  is a function of antenna type (beam angle  $\alpha$ ) and distance  $D$ . The recommended distance to the tank wall is indicated in the tables below. It is strongly recommended to avoid any mechanical obstacles within the highlighted area.

Horn antenna			
<b>Antenna size</b>	100 mm (4")		
<b>Beam angle (<math>\alpha</math>)</b>	8°		

Distance (D) (m [ft])	Beam diameter (W) (m [ft])	Recommended distance to wall (m [ft])	
		0° tilting	3° tilting
5 (16)	0.70 (2.3)	0.89 (2.9)	0.62 (2.0)
10 (33)	1.40 (4.6)	1.77 (5.8)	1.23 (4.0)
15 (49)	2.10 (6.9)	2.65 (8.7)	1.85 (6.1)
20 (66)	2.80 (9.2)	3.53 (12)	2.46 (8.1)
25 (82)	3.50 (11)	4.41 (14)	3.07 (10)
30 (98)	4.20 (14)	5.29 (17)	3.69 (12)

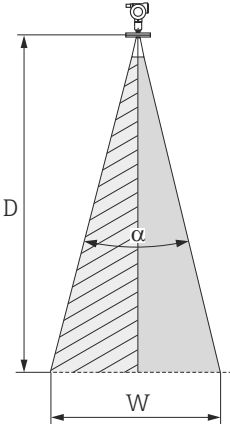

A0020805

Parabolic antenna		
<b>Antenna size</b>	200 mm (8")	250 mm (10")
<b>Beam angle (<math>\alpha</math>)</b>	4.4°	3.3°

Distance (D) (m [ft])	Recommended distance to wall (m [ft])	
5 (16)	0.35 (1.1)	0.2 (0.7)
10 (33)	0.70 (2.3)	0.5 (1.6)
15 (49)	1.05 (3.4)	0.75 (2.5)
20 (66)	1.40 (4.6)	1.05 (3.4)
25 (82)	1.75 (5.7)	1.3 (4.3)
30 (98)	2.10 (6.9)	1.6 (5.2)
35 (115)	2.45 (8.0)	1.85 (6.1)
40 (131)	2.80 (9.2)	2.10 (6.9)

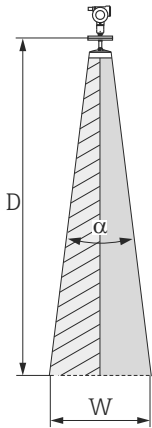

A0020806

**HINWEIS**

**Measuring error due to multiple echoes!**

- ▶ Ensure that **only one** tank wall (**not two** tank walls) is hit directly by the radar beam!

### Integrated air purge connection

In some applications, the integrated purge air connection can prevent clogging of the antenna.

- Permanent operation:  
recommended pressure range for purge air: 1.2 to 1.5 bar (18 to 22.5 psi) abs.
- Pulsed operation:  
max. pressure of purge air: 6 bar (90 psi) abs.

#### **HINWEIS**

**Moisture or humidity can accumulate and result in incorrect measurement results!**

- ▶ Use dry purge air!

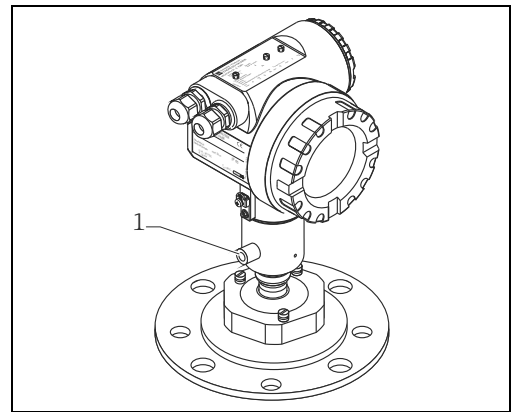

1 Purge air connection G 1/4"  
(max. torque 3.5 Nm (2.581 lbf ft))

A0020799

## Environment

<b>Ambient temperature range</b>	<p>Ambient temperature for the transmitter:</p> <ul style="list-style-type: none"> <li>Standard: -40 °C to +80 °C (-40 °F to +176 °F)</li> <li>For custody transfer measurement: -25 °C to +55 °C (-13 °F to +131 °F)</li> </ul> <p>For <math>T_u &lt; -20</math> °C (-4 °F) and <math>T_u &gt; +60</math> °C (+140 °F), the operation of the LCD is restricted. A weather protection cover should be used for outdoor operation if the device is exposed to direct sunlight.</p>
<b>Storage temperature</b>	-40 °C to +80 °C (-40 °F to +176 °F)
<b>Climate class</b>	DIN EN 60068-2-38 (test Z/AD)
<b>Degree of protection</b>	<ul style="list-style-type: none"> <li>Housing: IP65/68, NEMA 4X/6P</li> <li>Antenna: IP65/68, NEMA 4X/6P</li> </ul>
<b>Vibration resistance</b>	DIN EN 60068-2-64 / IEC 68-2-64: 20 to 2000 Hz, 1 (m/s <sup>2</sup> )/Hz
<b>Cleaning of the antenna</b>	The antenna can get contaminated, depending on the application. The emission and reception of microwaves can thus eventually be hindered. The degree of contamination leading to an error depends on the medium and the reflectivity, mainly determined by the dielectric constant $\epsilon_r$ . If the medium tends to cause contamination and deposits, cleaning on a regular basis is recommended. Care must be taken during spray-washing or mechanical cleaning to avoid damage to the antenna. The material compatibility has to be considered if cleaning agents are used! The maximum permitted temperature at the flange should not be exceeded.
<b>Electromagnetic compatibility (EMC)</b>	<ul style="list-style-type: none"> <li>Electromagnetic compatibility in accordance with all relevant requirements of the EN 61326 series and NAMUR recommendation (NE21). For details refer to the Declaration of Conformity. Maximum deviation &lt; 0.5 % of the span.</li> <li>A standard installation cable is sufficient if only the analogue signal is used. Use a screened cable when working with a superimposed communications signal (HART).</li> </ul>
<b>Approvals for custody transfer applications</b>	All aspects of OIML R85 are fulfilled.

Approvals for custody transfer applications	Version*
NMi + PTB (<1 mm [0.04 in]) type approval (→ <a href="#">14</a> )	A
NMi-witnessed initial verification (<1 mm [0.04 in]) (→ <a href="#">14</a> )	F
PTB-witnessed initial calibration (<1 mm [0.04 in]) (→ <a href="#">14</a> )	G
not selected; Inventory control (→ <a href="#">14</a> )	R

\* Order code in Product Configurator (→ [37](#))

## Process

<b>Process temperature range</b>	GLT, -40 °C to +200 °C (-40 °F to 391 °F)
<b>Process pressure limits</b>	<ul style="list-style-type: none"> <li>Parabolic antenna -1 to 16 bar (-15 to 240 psi)</li> <li>Horn antenna -1 to 16 bar (-15 to 240 psi)</li> <li>With Endress+Hauser UNI flange -1 to 1 bar (-15 to 15 psi)</li> </ul>
<b>Alignment device</b>	± 15° inclination seal: FKM Viton GLT



Antenna, seal	L1 (mm [in])	ød (mm [in])	L2 (mm [in])		Version* for standard flange
			UNI <sup>1)</sup>	Standard	
<b>Horn antenna</b>					
4" 100 mm	430 (16.9)	95 (3.74)	33 (1.3)	26.9 (1.06)	E
<b>Parabolic antenna</b>					
8" 200 mm	61 (2.4)	173 (6.81)	32 (1.26)	24.8 (0.98)	G
10" 250 mm	88 (3.5)	236 (9.29)	20 (0.8)	12.5 (0.49)	H

1) For the version in the order code, see Endress+Hauser UNI flange → [39](#)

Flange / Process connection	b (mm [in])	øD (mm [in])	Version*
<b>ANSI B16.5</b>			
4" 150 lbs	23.9 (0.94)	228.6 (9.0)	APJ
6" 150 lbs	25.4 (1.0)	279.4 (11.0)	AVJ
8" 150 lbs	28.4 (1.12)	342.9 (13.5)	AKJ
10" 150 lbs	30.2 (1.19)	406.4 (16.0)	A5J
<b>Flange JIS B2220</b>			
10K 100A	18 (0.71)	210 (8.27)	KHJ
10K 150A	22 (0.87)	280 (11.0)	KVJ
10K 200A	22 (0.87)	330 (13.0)	KDJ
10K 250A	24 (0.94)	400 (15.7)	K5J
<b>Flange JPI 7S -15</b>			
4" 100A 150 lbs	24,3 (0,96)	230 (9.06)	APJ
6" 150A 150 lbs	25,9 (1,2)	280 (11.0)	LJJ
8" 200A 150 lbs	29,0 (1,14)	345 (13.6)	LKJ
10" 250A 150 lbs	30,6 (1,2)	405 (15.9)	LLJ
<b>Flange EN1092-1 (suitable for DIN2527 C)</b>			
DN100 PN10/16	20 (0.79)	220 (8.66)	CQJ
DN150 PN10/16	22 (0.87)	285 (11.2)	CWJ
DN200 PN16	24 (0.94)	340 (13.4)	CXJ
DN250 PN16	26 (1.02)	405 (15.9)	C6J

\* Order code in Product Configurator (→ [37](#))

**Weight** 6 kg (13.23 lbs) + flange weight<sup>1)</sup>

1) Flange weights according to form sheet



Materials

Materials in contact with process

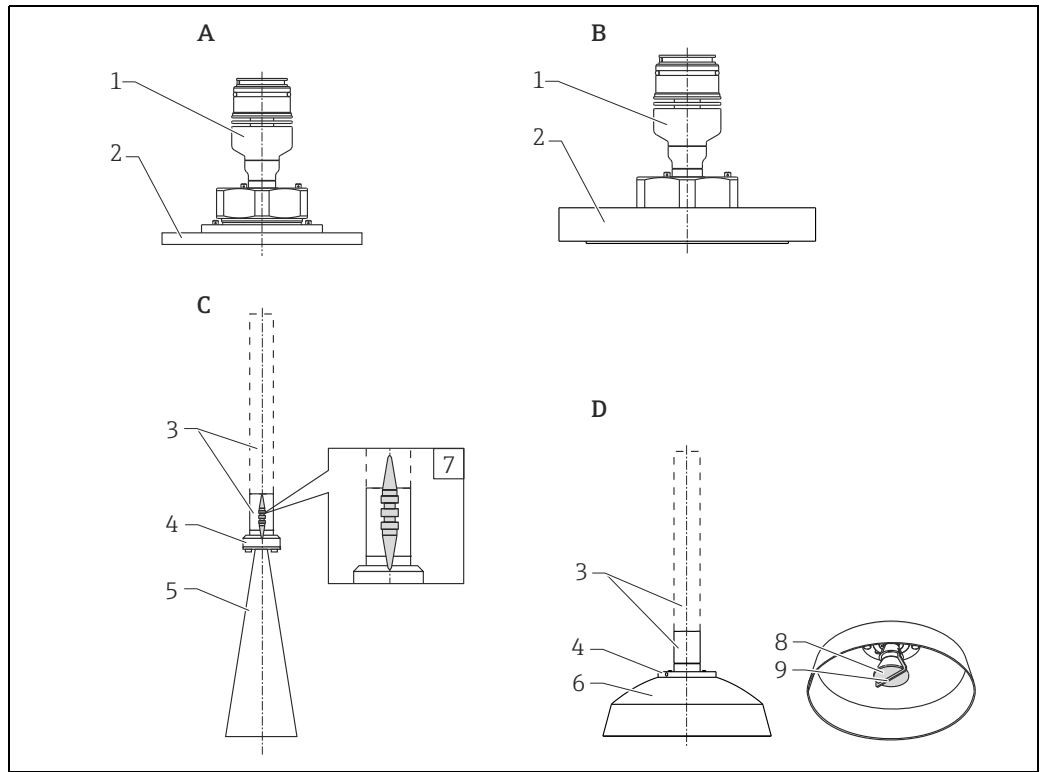

- A Alignment device with Endress+Hauser UNI flange
- B Alignment device with standard flanges
- C Horn antenna (with antenna extension)
- D Parabolic antenna (with antenna extension)

Pos.	Part	Material	
1	Adapter	316L (1.4404)	
	Plug	A4	316L (1.4404)
	Adapter (G → NPT)	316L (1.4404)	
	Seal	Viton	
2	Flange	316L (1.4404/1.4435)	
	Adapter	316L (1.4404)	
	Ball	316L (1.4404)	
	Screw nut	304 (1.4301)	
	Jammes ring	304 (1.4301)	
	Starting disk	304 (1.4301) with slide coating	
	Capstan head screw	A2	
	Seal	Viton	
3	Pipe	316L (1.4404)	
4	Parts for process separation	316L (1.4404)	
	Adapter Horn / Parabolic	316L (1.4404)	
5	Horn	316L (1.4404)	
	Screws	A4	
	Seal	FKM	

Pos.	Part	Material
6	Parabolic reflector	316L (1.4404)
	Screws	A4
	Seal	FKM
7	Process separating cone (horn antenna)	PEEK
8	Process separating cone (parabolic antenna)	PTFE
	Reflector	316L
	Bracket	316L

### Materials not in contact with process

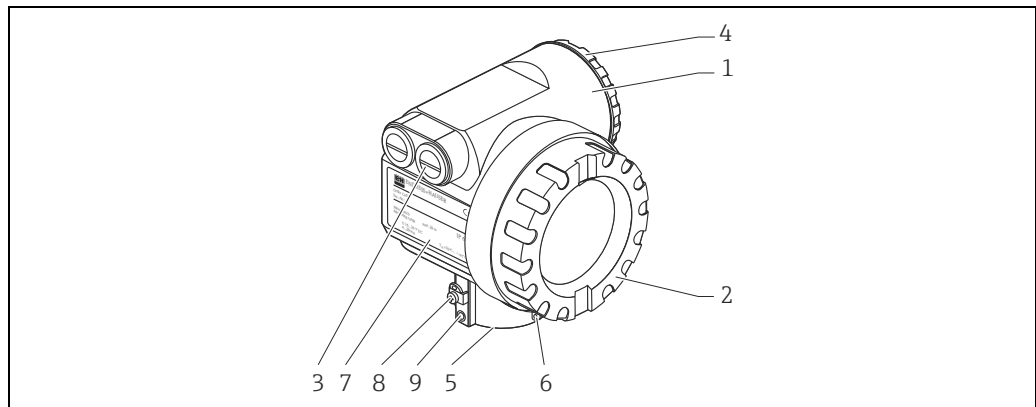

A0020714

Housing T12, aluminum

Pos.	Part	Material	
1	T12 housing	AlSi10Mg (aluminum, powder-coated)	
2	Cover (Display)	AlSi10Mg	
	Seal	Fa. SHS: EPDM 70pW FKN	
	Window	ESG-K-Glass (Toughened safety glass)	
	Sealing of the glass	Silicone sealing compound Gomastit 402	
3	Seal	Fa. SHS: EPDM 70 pW FKN	Trelleborg: EPDM E7502
	Cable gland	Polyamid (PA), CuZn nickel-plated	
	Plug	PBT-GF30	1.0718 galvanized
		PE	3.1655
Adapter	316L (1.4435)	AlMgSiPb (anodized)	
4	Cover (Connection compartment)	AlSi10Mg	
	Sealing	Fa. SHS: EPDM 70pW FKN	Trelleborg: EPDM E7502/ E7515
	Clamp	Screws: A4; Clamp: Ms nickel-plated; Spring washer: A4	
5	Sealing ring	Fa. SHS: EPDM 70pW FKN	Trelleborg: EPDM E7502/ E7515
6	Tag	304 (1.4301)	
	Rope	VA	
	Crimp sleeve	Aluminium	
7	Nameplate	316L (1.4404)	
	Groove pin	A4 (1.4571)	

Pos.	Part	Material
8	Ground terminal	Screws: A2; Spring washer: A4; Clamp: 304 (1.4301) Holder: 1.4310
9	Screw	A2-70

 Endress+Hauser supplies DIN/EN flanges made of stainless steel according to AISI 316L (DIN/EN material number 1.4404 or 1.4435). With regard to their temperature stability properties, the materials 1.4404 and 1.4435 are grouped under 13EO in EN 1092-1 Tab. 18. The chemical composition of the two materials can be identical.

**Type plate for custody transfer applications**

In addition to the standard type plate, the device features a type plate for custody transfer applications with the following statements:

- manufacturer
- device type
- label for custody transfer approval  
PTB : Label for custody transfer approval ("Z") and approval number  
NMI : Field for five-digit approval number
- year of manufacturing
- space for imprinted tank identification number
- statement of measuring range suitable for custody transfer approval including unit
- statement of ambient temperature range suitable for calibration to regulatory standards

The following statements are also required for calibration to regulatory standards. They are listed on the standard type plate and are not repeated here:

- date of manufacturing
- tester

The type plate for calibration to regulatory standards can be sealed. It is mounted with screws, therefore also available as a spare part. The "stamping" of the electronic compartment is achieved with the custody locking switch (compare figure, →  34) and does not require any additional stamping location.

 The fields are completed only if the version "F" or "G" was selected in the order code under "Weight + measure approval".

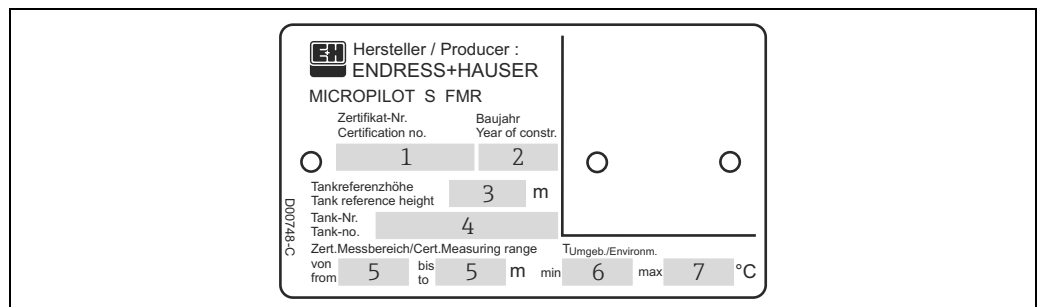

**NMI type plate (example)**



- 1 Certificate number
- 2 Year of manufacture
- 3 Tank reference height
- 4 Tank number
- 5 Certified measuring range from ... to ....
- 6 Min. ambient temperature
- 7 Max. ambient temperature

A0020413

## PTB type plate (example)

D00549-B	 Hersteller / Producer : <b>ENDRESS+HAUSER</b>								
	MICROPILOT S FMR								
	1	Baujahr Year of constr.							
	2	3							
	Tankreferenzhöhe Tank reference height								
	4	m							
	Tank-Nr. Tank-no.								
	5								
Zert.Messbereich/Cert.Measuring range		T <sub>Umgeb./Environn.</sub>							
von from	6	bis to	6	m	min	7	max	8	°C

A0020446

- 1 Approval number
- 2 Year and month of type approval
- 3 Year of manufacture
- 4 Tank reference height
- 5 Tank number
- 6 Certified measuring range from ... to ....
- 7 Min. ambient temperature
- 8 Max. ambient temperature

**Endress+Hauser UNI flange**

**Installation hints**

The number of bolts has sometimes been reduced. The bolt-holes have been enlarged to allow for the dimensions to be adapted. Therefore, the flange must be properly aligned with the counterflange before the bolts are tightened.

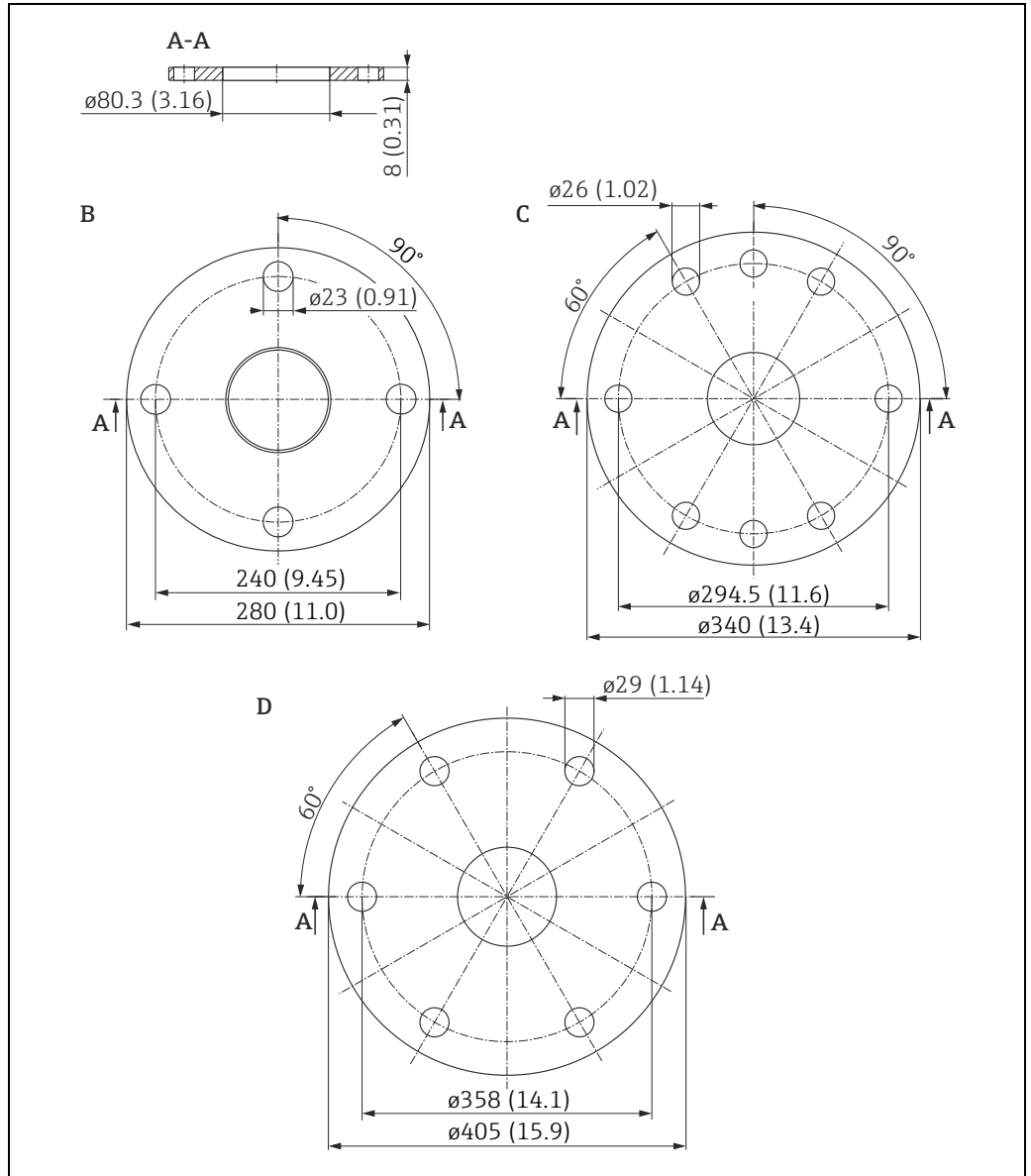

A0020793

Engineering unit mm (in)

Endress+Hauser UNI flange	Compatible with	Version*
B	DN150 PN16; ANSI 6" 150lbs; JIS 10K 150	XVJ
C	DN200 PN16; ANSI 8" 150lbs; JIS 10K 200	X3J
D	DN250 PN16; ANSI 10" 150lbs; JIS 10K 250	X5J

\* Order code in Product Configurator (→ 37)

## Alignment device with Endress+Hauser UNI flange

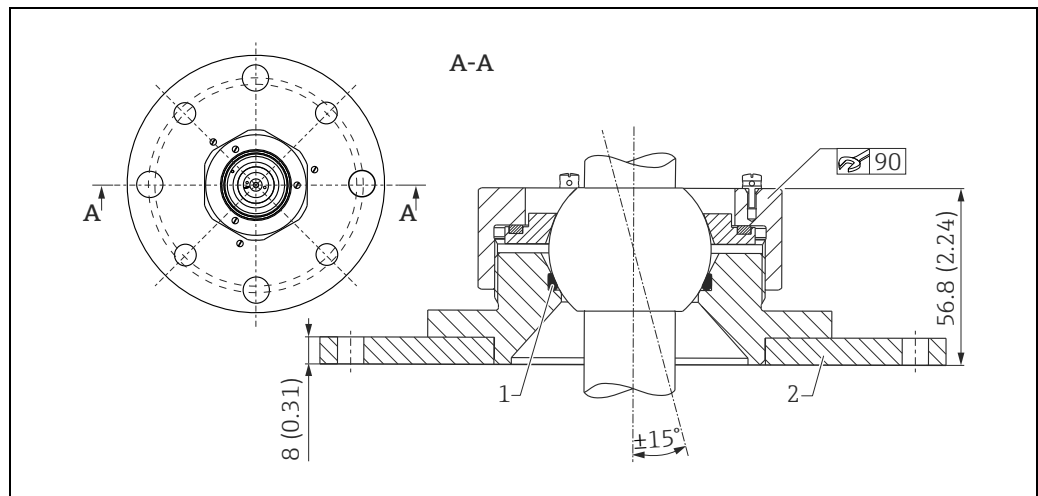

Engineering unit mm (in)

- 1 Viton seal
- 2 Endress+Hauser UNI flange DN200/DN250

See also sensor alignment tool → 38.

## Operability

### Operation concept

The display of the process value and the configuration of the Micropilot is done locally by means of a large 4-line alphanumeric display with plain text information. The guided menu system with integrated help texts ensures a quick and safe commissioning. Display and operation is selectable from one out of six languages (English, German, French, Italian, Dutch, Spanish and Japanese). During the first start-up, the device explicitly asks for the desired unit / language. To access the display the cover of the electronic compartment may be removed even in hazardous area (Ex ia, IS). Remote commissioning, including documentation of the measuring point and in-depth analysis functions, is supported via the FieldCare, the graphical operating software for Endress+Hauser time-of-flight systems.

Access to the electronics can be prevented by means of a custody locking switch that locks the device settings.

The custody locking switch can be sealed for custody transfer applications.

### Local operation

#### Operation with VU331

Using the LC-Display, configuration is possible directly at the device via the operating keys. All device functions can be set through a menu system. The menu consists of function groups and functions. Within a function, application parameters can be read or adjusted. The user is guided through a complete configuration procedure.

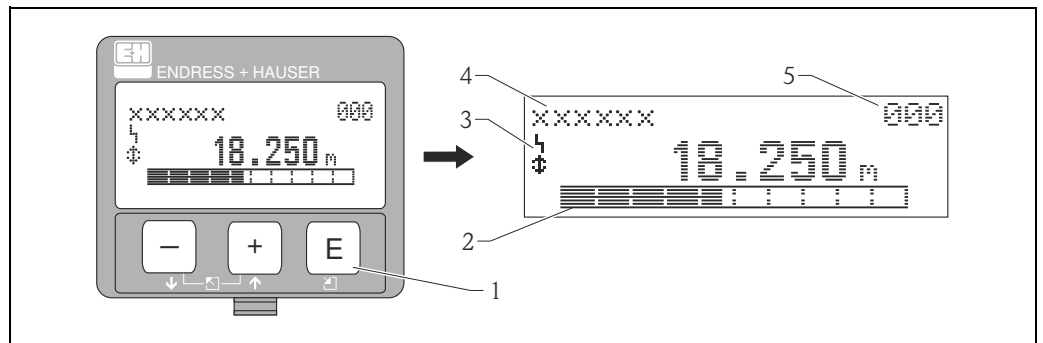

- 1 Operating keys
- 2 Bar graph
- 3 Symbols
- 4 Function name
- 5 Parameter identification number

Remote configuration

The Micropilot S can be remotely operated via HART. On-site adjustments are also possible.

Operation with FieldCare

FieldCare is an asset management tool based on FDT technology from Endress+Hauser. With FieldCare, you can configure all Endress+Hauser devices as well as devices from other manufacturers that support the FDT standard. Hardware and software requirements can be found on the internet at: [www.de.endress.com](http://www.de.endress.com) → Search: FieldCare → FieldCare → Technical data.

FieldCare supports the following functions:

- Configuration of transmitters in online operation
- Signal analysis via envelope curve
- Tank linearization
- Loading and saving device data (upload/download)
- Documentation of measuring point

Connection options:

- HART via Commubox FXA195 and the USB port on a computer
- Commubox FXA291 with ToF Adapter FXA291 (USB) via service interface

Menu-guided commissioning

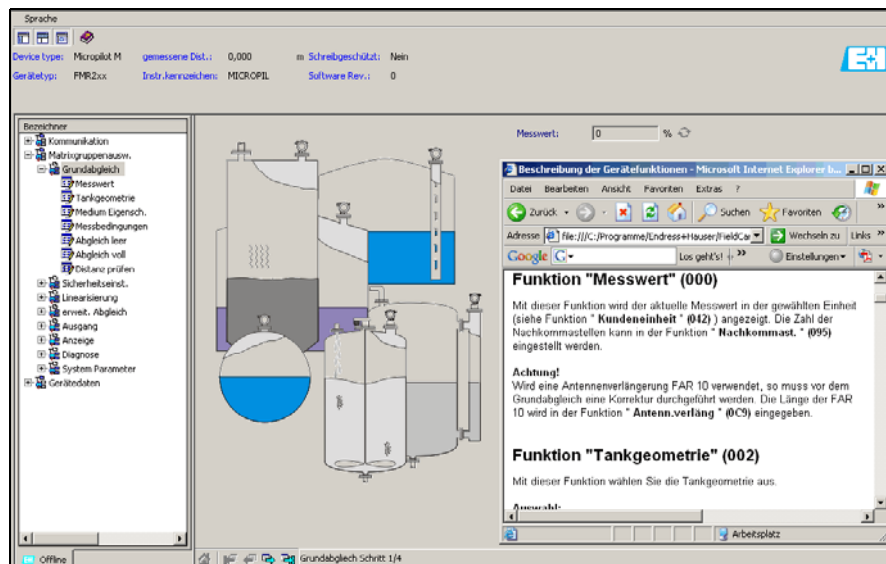

A0021211-EN

Signal analysis via envelope curve

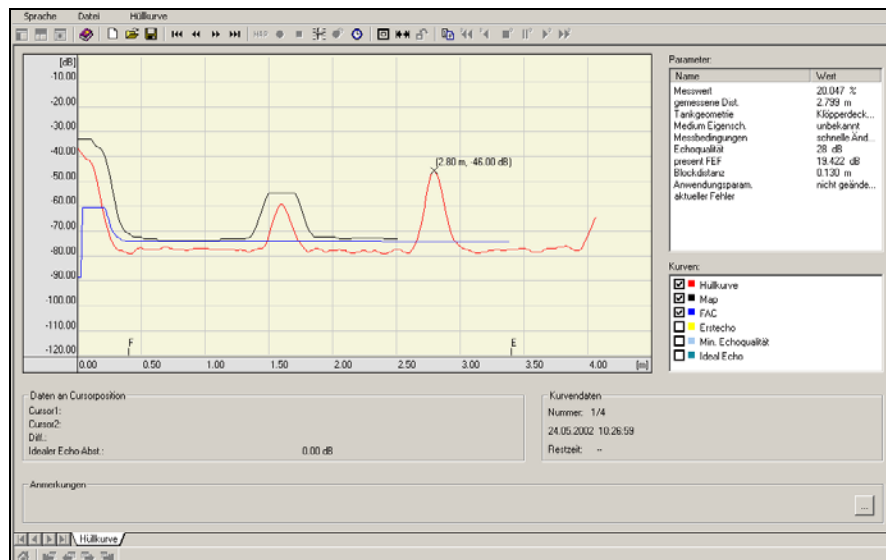

A0021212-EN



### Tank linearization

The screenshot shows the 'Tank linearization' software interface. On the left is a table with the following data:

Index	Eingabe Füllst. (m)	Eingabe Volumen (l)
1	0.000	0.000
2	0.085	1.772
3	0.129	3.765
4	0.194	5.980
5	0.250	8.417
6	0.323	11.080
7	0.387	13.866
8	0.452	17.078
9	0.516	20.411
10	0.591	23.965
11	0.645	27.736
12	0.710	31.702
13	0.774	35.884
14	0.839	39.959
15	0.900	44.256
16	0.960	48.546
17	1.032	53.243
18	1.087	57.120
19	1.161	61.949
20	1.226	65.580
21	1.290	69.530
22	1.355	73.409
23	1.419	77.068
24	1.494	80.588
25	1.548	83.727
26	1.613	86.722
27	1.677	89.452
28	1.742	92.030
29	1.806	94.360
30	1.871	96.459
31	1.935	98.339
32	2.000	100.000

The right side of the interface features a 3D diagram of a tilted cylindrical tank with dimensions H, E, F, D, L, and P. Below the diagram are input fields for:

- H: 2.2 [m]
- Winkel: 15
- Leer (E): 2.2 [m]
- Boden Typ (rechts): flach
- Voll (F): 2 [m]
- Boden Typ (links): flach
- Durchmesser (D): 2 [m]
- Länge (L): 5 [m]
- Stützenposition (P): 2.5 [m]

At the bottom, there are controls for 'Typ' (zylindrisch liegende Tanks), 'Füllhöhe' (automatisch/benutzerdefiniert), and 'Start Volumen' (null/berechnet). A 'Tabelle berechnen' button is also present.

A0021213-EN

### Operation with Field Communicator 475

With the Field Communicator 475, all device functions can be configured via a menu operation.



Further information on the handheld terminal can be found in the relevant Operating Instructions included in the transport bag of the Field Communicator 475.

Display elements

**Liquid crystal display (LCD):**

Four lines with 20 characters each. Display contrast adjustable through key combination.

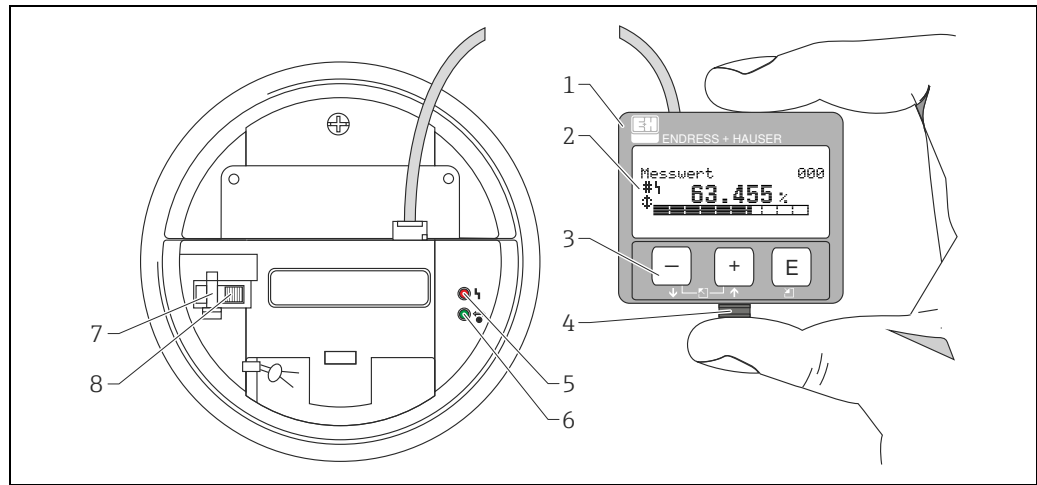

A0020494-EN

- |   |                        |   |                        |
|---|------------------------|---|------------------------|
| 1 | Liquid crystal display | 5 | Red LED                |
| 2 | Symbols                | 6 | Green LED              |
| 3 | Operating keys         | 7 | Custody locking switch |
| 4 | Snap fit               | 8 | Sealing pin            |

**i** To access the display, it is possible to open the cover of the electronics compartment even in an explosion hazardous area. The LCD can be removed for easy operation by simply pressing the snap fit (see graphic above). It is connected to the device by means of a 500 mm (19.7 in) long cable.

**Display symbols**

The following table describes the symbols that appear on the liquid crystal display:

Symbols	Meaning
	<b>ALARM_SYMBOL</b> This alarm symbol appears when the device is in an alarm state. If the symbol flashes, this indicates a warning.
	<b>LOCK_SYMBOL</b> This lock symbol appears when the device is locked, i.e. if no input is possible.
	<b>COM_SYMBOL</b> This communication symbol appears when a data transmission via e.g. HART is in progress.
	<b>Calibration to regulatory standards disturbed</b> If the device is not locked or suitability for custody transfer measurement cannot be guaranteed, this will be indicated on the display by this symbol.

*Light emitting diodes (LEDs):*















There is a green and a red LED beside the LCD.

LED	Meaning
red LED continuously on	Alarm
red LED flashes	Warning
red LED off	No alarm
green LED continuously on	Operation
Green LED flashes	Communication with external device



**Operating elements**

The operating elements are located inside the housing and are accessible for operation by opening the lid of the housing.

**Function of the keys**

Key(s)	Meaning
 or 	<ul style="list-style-type: none"> <li>▪ Navigate upwards in the selection list.</li> <li>▪ Edit numeric value within a function.</li> </ul>
 or 	<ul style="list-style-type: none"> <li>▪ Navigate downwards in the selection list.</li> <li>▪ Edit numeric value within a function.</li> </ul>
  or 	Navigate to the left within a function group.
	<ul style="list-style-type: none"> <li>▪ Navigate to the right within a function group.</li> <li>▪ Confirm entries.</li> </ul>
 and  or  and 	Contrast settings of the LCD.
 and  and 	Hardware lock / unlock After a hardware lock, an operation of the device via display or communication is not possible! The hardware can only be unlocked via the display. An unlock parameter must be entered to do so.

## Certificates and approvals

<b>CE approval</b>	The measuring system meets the legal requirements of the EC-guidelines. Endress+Hauser confirms the device passing the required tests by attaching the CE-mark.
<b>C-Tick symbol</b>	The measuring system meets the EMC requirements of the "Australian Communications and Media Authority (ACMA)".
<b>Ex approval</b>	<ul style="list-style-type: none"> <li>▪ ATEX</li> <li>▪ CSA</li> <li>▪ FM</li> <li>▪ NEPSI</li> <li>▪ TIIS</li> </ul> <p>When operating in hazardous areas, additional safety instructions must be observed. These can be found in the separate document entitled "Safety Instructions" (XA), which is included in the scope of delivery. The applicable XA is indicated on the nameplate.</p> <p> Details on the certificates available and the relevant XAs can be found in the "Documentation" section under "Safety instructions" →  39.</p>
<b>Overfill prevention</b>	WHG, see ZE00243F/00/DE.
<b>RF approvals</b>	R&TTE 1999/5/EG, FCC CRF 47, part 15
<b>CRN approvals</b>	Versions with a CRN approval (Canadian Registration Number) are listed in the corresponding registration documents. CRN-approved devices are assigned the registration number OF10904.5CADD2.
<b>Approvals for custody transfer applications</b>	All aspects of OIML R85 are fulfilled.
<b>External standards and guidelines</b>	<p>To conception and development for Micropilot S have been followed the external standards and guidelines:</p> <p><b>EN 60529</b> Protection class of housing (IP-code)</p> <p><b>EN 61010</b> Safety regulations for electrical devices for measurement, control, regulation, and laboratory use</p> <p><b>EN 61326</b> Emissions (equipment class B), compatibility (appendix A – industrial area)</p> <p><b>NAMUR</b> Standards committee for measurement and control in the chemical industry</p> <p><b>API (American Petroleum Institute)</b> Particulary "Manual of Petroleum Measurement Standards"</p> <p><b>OIML R85 (Organisation Internationale de Métrologie Légale)</b></p>

## Ordering information

### Ordering information

Detailed ordering information is available as follows:

- In the Product Configurator on the Endress+Hauser website: [www.endress.com](http://www.endress.com) ▶ Select country ▶ Instruments ▶ Select device ▶ Product page function: Configure this product
- From your Endress+Hauser sales center: [www.endress.com/worldwide](http://www.endress.com/worldwide)



### Product Configurator - the tool for individual product configuration

- Configuration data updated on a daily basis
- Depending on the device: Direct input of data specific to measuring point, such as measuring range or operating language
- Automatic verification of exclusion criteria
- Automatic generation of order code with breakdown in PDF or Excel output format
- Possibility to order directly from the Endress+Hauser online shop

### Scope of delivery

The scope of delivery comprises:

- Device, mounted
- Optional accessories
- 2 lead seals
- CD-ROM with Endress+Hauser operating software
- Brief Operating Instructions KA01059F/00/EN for fast commissioning (included with device)
- Brief Operating Instructions KA00255F/00/A2 (basic calibration/trouble-shooting), stored in device
- Approval documentation, if not included in the Operating Instructions
- CD-ROM with additional technical documentation, e.g.
  - Operating Instructions
  - Description of Instrument Functions

## Accessories

A variety of accessories is available for the Micropilot S. They can be ordered separately from Endress+Hauser.

### Device-specific accessories

#### Weather protection cover

A weather protection cover made of stainless steel is available for outdoor installation (order code: 543199-0001). The shipment includes the protective cover and tension clamp.

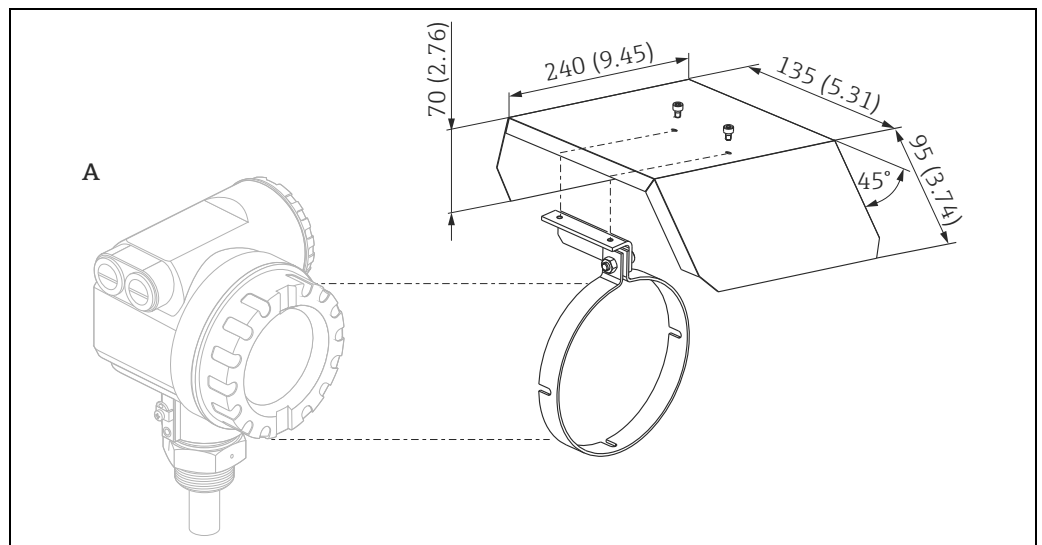

Engineering unit mm (in)

A Housing T12

A0020691

**Sensor alignment tool for alignment device**

A sensor alignment tool is recommended to be used at the time of installation for FMR540 with alignment device. Order no.: 52026756. For details, see instructions KA00274F/00/A2.

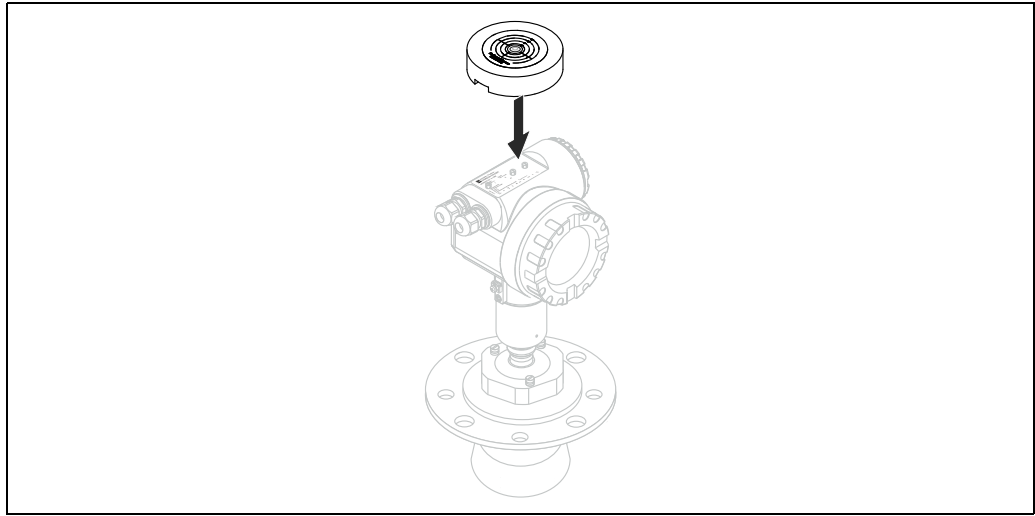

A0020790

**Communication-specific accessories****Commubox FXA195 HART**

For intrinsically safe communication with FieldCare via the USB interface. For details, see Technical Information TI00404F/00/EN.

**Commubox FXA291**

The Commubox FXA291 connects Endress+Hauser field devices with CDI interface (= Endress+Hauser Common Data Interface) to the USB interface of a personal computer or a notebook. For details, see Technical Information TI00405C/07/EN.



For the device you need the "ToF Adapter FXA291" as an additional accessory.

**ToF Adapter FXA291**

The ToF Adapter FXA291 connects the Commubox FXA291 via the USB interface of a personal computer or a notebook to the device. For details, see instructions KA00271F/00/A2.

**Field Xpert**

Compact, flexible and robust industrial handheld terminal for remote configuration and measured value retrieval via HART current output and via FOUNDATION Fieldbus. For details, see Operating Instructions BA00060S.

**Service-specific accessories****FieldCare**

FDT-based Plant Asset Management Tool from Endress+Hauser. It can configure all smart field units in your system and helps you manage them. By using the status information, it is also a simple but effective way of checking their status and condition. For details, see Operating Instructions BA00027S and BA00059S.

## Documentation

### Standard documentation

The following document types are available:

- On the CD supplied with the device
- In the Download Area of the Endress+Hauser website → [www.de.endress.com](http://www.de.endress.com) → Download

Documentation	
Operating Instructions	BA00326F/00/EN
Description of instrument functions	BA00341F/00/EN
Brief Operating Instructions (for fast commissioning)	KA01059/00/EN
Brief Operating Instructions (in the device)	KA00255F/00/A2

### Supplementary device-dependent documentation

Device	Documentation	
Tank Side Monitor NRF590	Technical Information	TI00402F/00/EN
	Operating Instructions	BA00256F/00/EN
	Description of Instrument Functions	BA00257F/00/EN

### Safety Instructions

Depending on the approval, Safety Instructions (XA) are supplied with the device. These instructions are an integral part of the Operating Instructions.

Certificate/type of protection	Documentation	Version*
ATEX II 1/2 G Ex ia IIC T6	XA00338F	1
ATEX II 1/2 G Ex ia IIC T6 + WHG	XA00338F + ZE00243F/00/EN	6
ATEX II 3G Ex nA IIC T6	XA00231F	G
FM IS Cl.I Div.1 Gr.A-D	XA00554F	S
CSA IS Cl.I Div.1 Gr.A-D	XA00539F	U
NEPSI Ex ia IIC T6	XA00579F	I
TIIS Ex ia IIC T2	–	K
TIIS Ex ia IIC T6	–	L

\* Order code in Product Configurator (→  37)



The nameplate indicates which Safety Instructions (XA) apply to the device.



[www.addresses.endress.com](http://www.addresses.endress.com)

---