

**FLUKE®**

# Laser Alignment Tool

*Fluke 832*

• **Users Manual**

# Fluke 832

**On-board help**

Version: 1.0

Edition: 02.2026

Part No.: DOC 54.200.EN

# Contents

---

<b>Contents</b> .....	<b>3</b>
<b>Introduction</b> .....	<b>9</b>
How to use the on-board help .....	9
Documentation .....	10
<b>Home screen</b> .....	<b>11</b>
<b>Configuration</b> .....	<b>12</b>
Product features .....	14
<b>Built-in camera</b> .....	<b>15</b>
Gallery .....	15
<b>RFID</b> .....	<b>17</b>
Assign a saved asset to an RFID tag .....	17
Open an asset measurement assigned to an RFID tag .....	18
<b>Using Cloud drive</b> .....	<b>20</b>
Transfer an asset to the Cloud drive .....	20
Download an asset from Cloud drive .....	20
<b>Components</b> .....	<b>21</b>
Rugged device .....	21
Device interface .....	23
Charge the battery .....	23
<b>Core components</b> .....	<b>25</b>
Core laser .....	25
Core sensor .....	26
Sensor LEDs .....	27
Charge sensor and/or laser .....	27
Open the sensor/laser aperture .....	27
Laser and sensor labels .....	28
<b>Mounting components</b> .....	<b>29</b>
Mount brackets .....	29

Mount sensor and laser .....	30
<b>Dimensions .....</b>	<b>31</b>
Train setup and fixation .....	32
<b>Machine properties .....</b>	<b>34</b>
Toggle .....	34
Machine colour .....	34
Thermal growth .....	35
Thermal growth calculator .....	36
Multiple feet .....	38
<b>Coupling properties .....</b>	<b>40</b>
Targets .....	40
<b>Tolerances .....</b>	<b>42</b>
Available tolerance tables .....	42
ANSI standard specification tolerances .....	43
User defined tolerances .....	44
Asymmetric and symmetric tolerances .....	45
Tolerance table based on coupling format .....	46
Suggested consolidated shaft alignment tolerances .....	47
<b>Laser beam adjustment .....</b>	<b>49</b>
Laser adjustment wizard .....	49
<b>Laser beam adjustment (Core) .....</b>	<b>51</b>
Core laser and sensor .....	51
<b>XY View .....</b>	<b>53</b>
<b>Initializing sensor .....</b>	<b>56</b>
<b>Measurement .....</b>	<b>57</b>
Averaging .....	58

<b>Measurement modes</b> .....	<b>59</b>
<b>Static measurement</b> .....	<b>60</b>
<b>Active Clock measurement</b> .....	<b>62</b>
Take measurement points automatically .....	64
<b>Extend measurement range manually</b> .....	<b>66</b>
<b>Measurement table</b> .....	<b>68</b>
Measurement quality .....	69
<b>Results</b> .....	<b>71</b>
Results options .....	73
Sign convention .....	73
<b>Multiple feet results</b> .....	<b>74</b>
Foot corrections .....	74
<b>Saving asset measurements</b> .....	<b>76</b>
Saving an asset .....	76
Asset list options .....	77
Default template .....	81
<b>Generate reports</b> .....	<b>83</b>
Generate measurement reports .....	83
Sections of the report .....	84
Other generating report screen elements .....	85
Report logo .....	86
Add signature to report .....	87
<b>Live Move screen</b> .....	<b>88</b>
Live Move .....	88
<b>What is soft foot</b> .....	<b>91</b>
Parallel soft foot .....	91
Angular soft foot .....	91
Checking and correcting soft foot conditions .....	92

<b>Soft foot</b> .....	<b>93</b>
Sensor measurement .....	93
Manual entry .....	94
<b>Vertical flanged machines</b> .....	<b>95</b>
Marking measurement positions .....	95
Setup .....	97
<b>Vertical flanged machines – Static clock</b> .....	<b>99</b>
Measure with Static measurement mode .....	99
<b>Vertical results</b> .....	<b>101</b>
Shimming modes .....	101
Sign convention .....	101
<b>Live Move – Vertical machines</b> .....	<b>103</b>
Correct angularity .....	103
Correct offset .....	103
<b>Horizontal flanged machines</b> .....	<b>106</b>
Flange-mounted horizontal machines .....	106
Set-up .....	106
<b>Core sensor firmware update</b> .....	<b>108</b>
Update sensor firmware to a newer version .....	108
Notification on sensor and laser calibration .....	110
<b>Best practice</b> .....	<b>113</b>
Mount sensor and laser .....	113
Enter dimensions .....	113
Initializing sensor .....	113
Causes that can influence measurement .....	114
Results and Live Move .....	114
<b>Appendix</b> .....	<b>115</b>
Update device to a newer firmware version .....	115
Documentation .....	117



<b>Technical data – Rugged tablet</b> .....	<b>119</b>
<b>Technical data – Core sensor</b> .....	<b>120</b>
<b>Technical data – Core laser</b> .....	<b>121</b>

This page intentionally left blank

## Introduction





This on-board help provides information to support users of the Product.

### How to use the on-board help

The on-board help is accessed through the home screen. Tap  (**Home** icon) then the question mark icon . The on-board help is shown.

Tap the question mark icon  shown on the screen to open the related context sensitive help.



- (1) Tap  to return to the start screen.
- (2) Tap  to go back.
- (3) Tap  to go to the opening page of this on-board help.
- (4) Tap  to go forward.
- (5) Tap  to search for text in the on-board help. A search field together with an onscreen keyboard appears.
- (6) Throughout this on-board help, image thumbnails have been used. Tap the image thumbnail to enlarge the image. To zoom out and proceed, tap the enlarged image.
- (7) The navigation pane hide arrow is used to hide the navigation menu items. Tap the

arrow to hide or show the navigation menu items.

- **(8)** This screen-specific help icon is used to access the context sensitive help.



**Note**

It is recommended to scroll to the bottom of the page to be able to access other related topics which are frequently used throughout the on-board help.

## Documentation



**Note**

This on-board help and other relevant and related customer documents are saved as PDF files in the folder **Manuals** within the rugged device. To access this folder, the rugged device is connected to a Windows PC. Allow the Windows PC to access the rugged device and then double-click the internal storage to access the required folder.

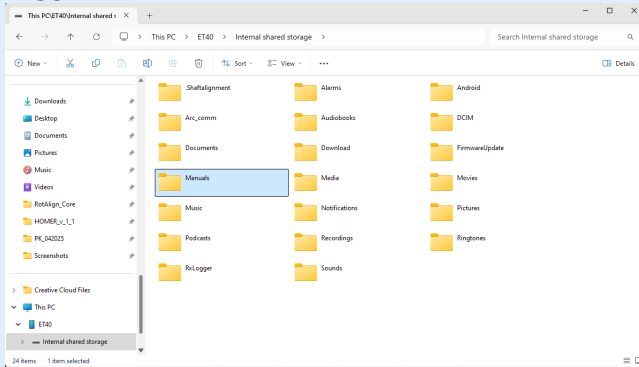

## Home screen

Switch the device on to show the home screen. Alternatively, tap  when in the application to show the home screen.

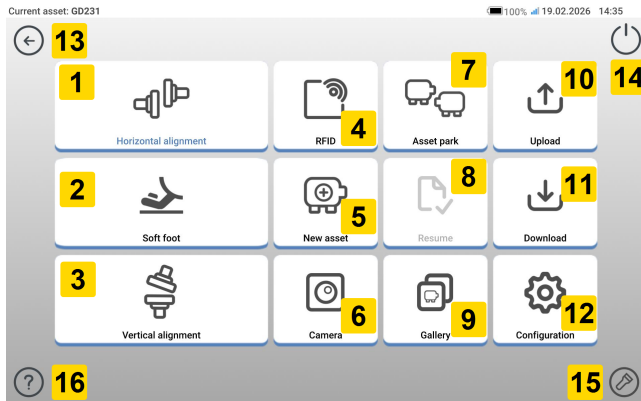

Tap the related icon to open related function:

- **1 Horizontal alignment** icon is used to access the horizontal alignment application.
- **2 Soft foot** icon is used to access soft foot measurement.
- **3 Vertical alignment** icon is used to access the vertical alignment application. If this icon is off, tap **New asset** icon (**5**) to start the vertical alignment icon.
- **4 RFID** icon is used to open assets assigned to related RFID tags.
- **5 New asset** icon is used to start a new asset (this may be a pump-motor combination).
- **6 Camera** icon is used to access the built-in camera.
- **7 Asset park** icon is used to show all saved assets and templates.
- **8 Resume** icon is used to resume last asset opened (provided it was saved) when the device is switched on.
- **9 Gallery** icon is used to show all images taken within the alignment applications.
- **10 Upload** icon is used to save asset measurements in the Cloud drive.
- **11 Download** icon is used to open asset measurements from the Cloud drive.
- **12 Configuration** icon is used to configure the alignment application settings (which include language, date, time, default settings), and access its built-in mobile connectivity. Mobile connectivity lets the device access the Cloud functionality, which lets files be shared wireless.
- **13 Back** icon is used to return to previous screen.
- **14 Power-off** icon is used to put the rugged device to sleep mode.
- **15 Flashlight** icon is used to turn the rugged device LED flash on/off.
- **16 Help** icon is used to show the on-board help file.

## Configuration

From the home screen, tap  the configuration icon to access these configuration items:

- **System settings** sets these items:

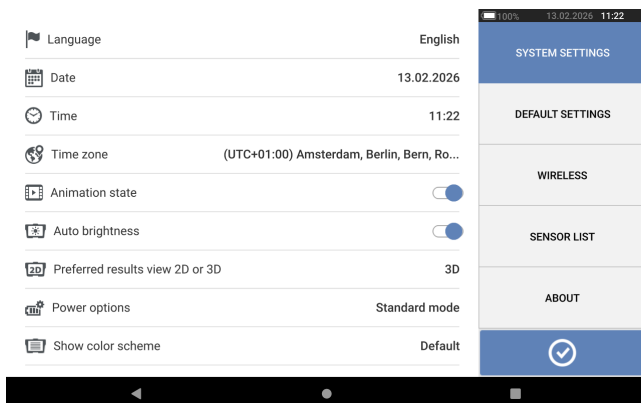

> Language (system language); > Date; > Time; > Time zone;

> Animation state — regulates the transition between the dimension, measure and results screens. Two options are available – fast and standard. If **Animation state** is on, the transition between screens is set to standard and therefore noticeable. If off, the transition is fast.

> Auto brightness – adjusts the display brightness of the touch device. If **Auto brightness** is on, the display brightness adjusts automatically. If off, then the display brightness may be manually adjusted by dragging the brightness slider to the left or right. For open applications, the device brightness is controlled in display settings.

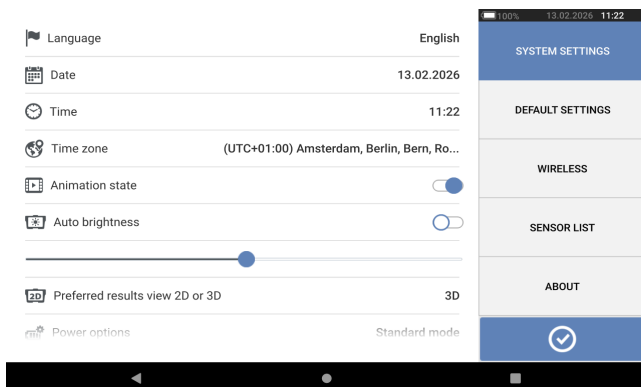

> Preferred results view 2D or 3D

> Power options – used to manage the power usage in the touch device. The four power modes available are: **Standard** (the display dims after 10 minutes and goes to sleep mode after 20 minutes), **Maximum** (no dimming and no sleep mode), **Presentation** (the display dims after 1 hour, but never enters the sleep mode) and **Minimum** (the display dims after 3 minutes and goes to sleep mode after 5 minutes). To get out of the sleep mode, press the power key.

For open applications, the screen timeout is controlled in display settings.

> Show color scheme – used to set display appearance either light or dark. Use the pop-up menu and select necessary appearance.

- **Default settings** are used to set units of length, angle and temperature; the default diameter may be set here. It is also used to activate or deactivate the automatic start of IntelliSweep / Sweep as well as automatic collection of measurements after stabilization, especially in point measurement modes. The type of tolerance to be used may

also be set here.

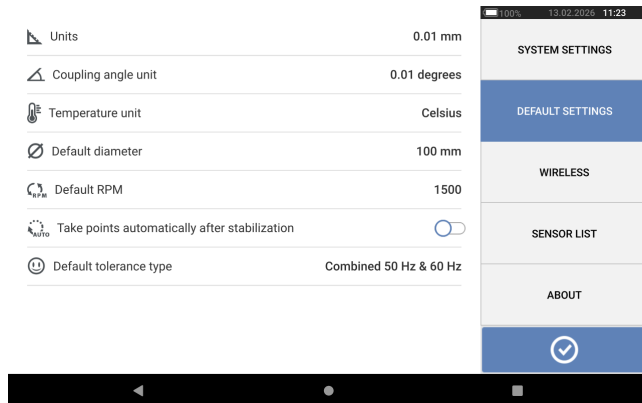

**Note**

When metric units are used, the resolution of physical quantities used in the device may be set to two (0.01 mm) or three (0.001 mm) decimal places. This measurement precision is available in Measurement, Results and Live Move screens. The Dimensions screen uses only positive integers.

The screenshot shows the 'DEFAULT SETTINGS' screen with a yellow box highlighting the 'Default diameter' dropdown menu. The dropdown menu is open, showing three options: '0.01 mm' (selected), '0.001 mm', and 'inch'. The 'Units' field is also highlighted with a yellow box and shows '0.01 mm'.

The set time zone is coupled to the default RPM unless the default RPM is edited independently. If the time zone is set, for example, as Central America, the default RPM is 1800. If it is set as London, the default RPM is 1500.

- When activated, **Wireless connection** is used to connect the rugged device to available WiFi networks.

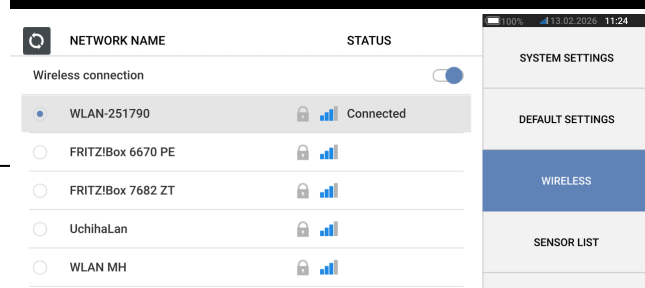
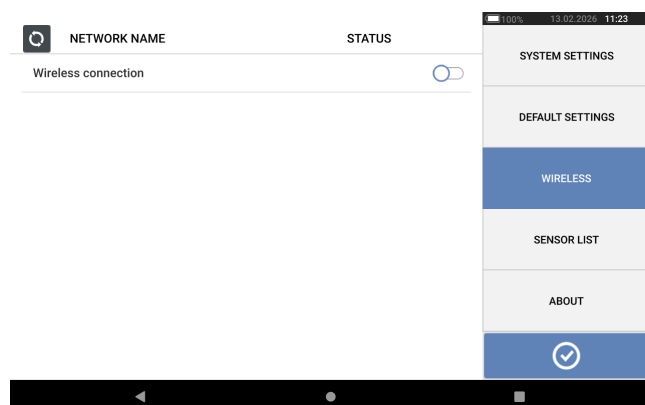



**Note**

The rugged tablet may be connected only to WiFi networks that do not open separate web browsers to login.

- **Sensor list** shows all available sensors.

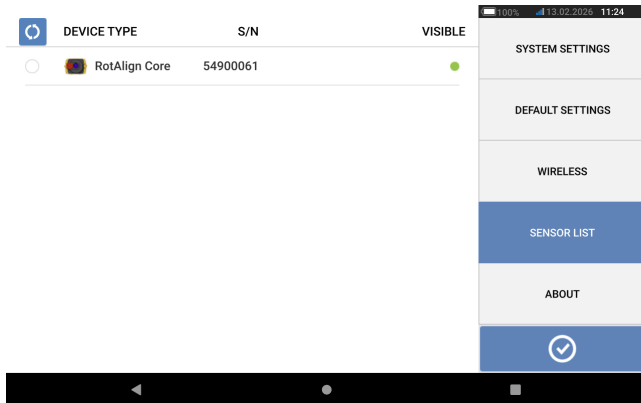

- The **About** screen shows the device serial number, firmware version of the application and available memory space.

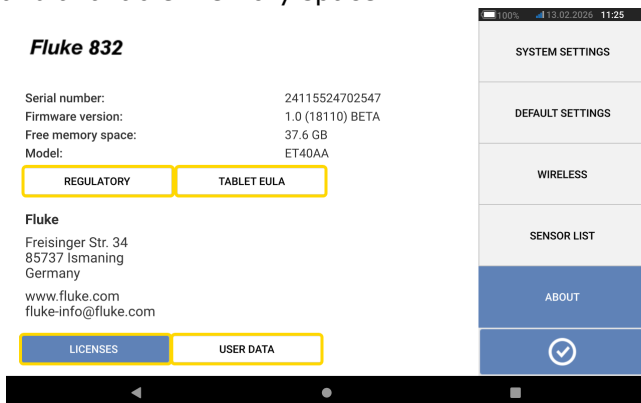

Tap **LICENSES** to see applicable GNU General Public License information.

Tap **REGULATORY** to see device regulatory markings for approved country radio certificates.

Tap **TABLET EULA** to see the device end user license agreement.

Tap **FACTORY RESET** to restore the device to its factory settings. If confirmed, all application data will be deleted, and a new PIN login must be created.

**Product features**

The Product features are:



Soft foot, Live Move (V or H), 8-point Active Clock, Static feet, Multiple feet, Quality factor, Standard deviation, Short flexible couplings, Suggested and user-defined tolerances, Spacer coupling, Thermal growth, Targets, Vertical Alignment

## Built-in camera

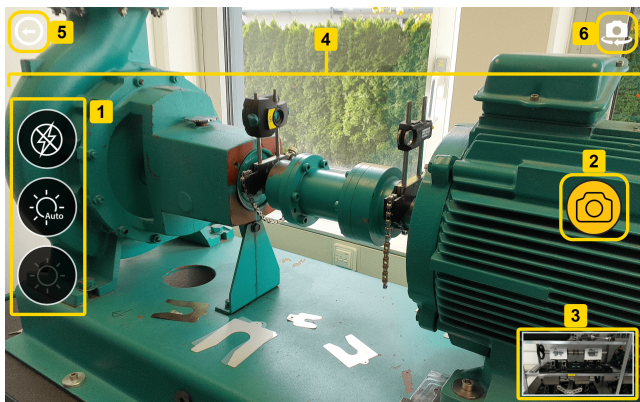
From the home screen, tap  to start the camera function.



Focus the device on the object to be photographed. The object is displayed on the screen.

- **(1)** Camera settings for indoor, outdoor and night imaging, plus automatic light setting – Tap necessary light setting icon (Flash may be turned on/off; Auto mode is for automatic light setting).
- **(2)** Tap  to take a photo of the object focused on the display.
- **(3)** Tap this location to access the device gallery. All images taken with the device are saved in this location.
- **(4)** Object to be photographed
- **(5)** Tap  to return to home screen.
- **(6)** Tap  to switch between the front- and rear-facing cameras.

## Gallery

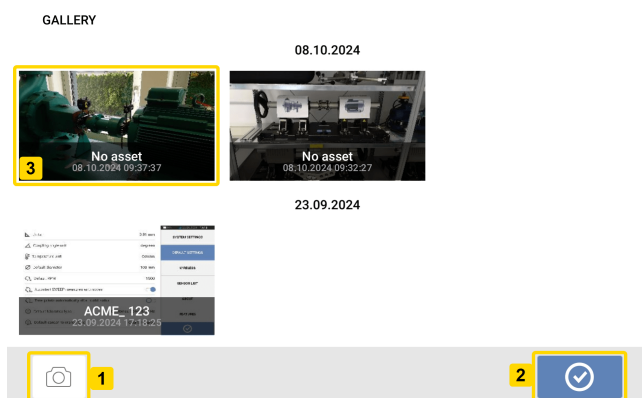

To view all images saved in the gallery, touch then drag up or down. All images are displayed as miniatures.

- **(1)** Tap  to go back to the image settings screen where objects may be photographed.

- **(2)** Tap  to go to the home screen.
- **(3)** Tap any miniature to view the image in full scale.

To delete an image from the gallery, tap the necessary image. The image appears in full scale. Tap the trash icon **(1)** to delete the image from the gallery.

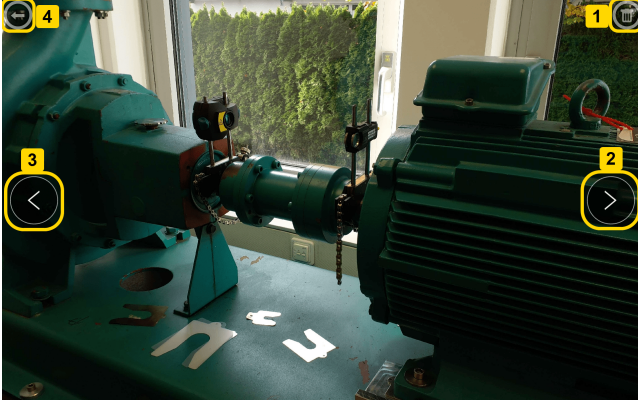

Use the arrow icons **2/3** to scroll the images in the gallery.

Tap  **(4)** to go to the gallery home screen.



- **(1)** Near Field Communication (NFC) antenna symbol

As soon as data has been written on the RFID tag, the related hint is shown on the screen.

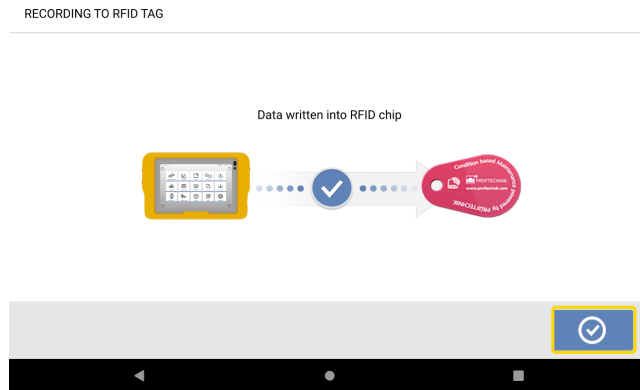

Tap  to exit the screen.



**Note**  
If however, data had already been assigned to the RFID tag, a hint to request data to be overwritten is shown.

## Open an asset measurement assigned to an RFID tag

From the home screen, tap .

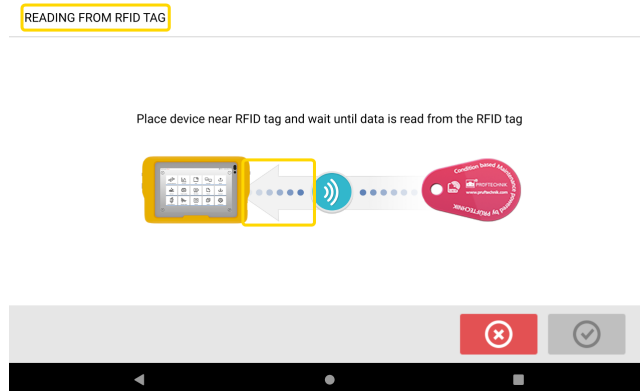

Position the rugged device such that its built-in NFC antenna is as close to the RFID tag as possible (less than a centimeter).

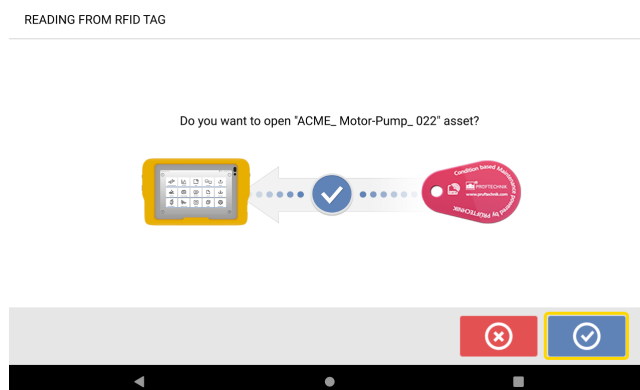

Tap  to open the asset measurement.

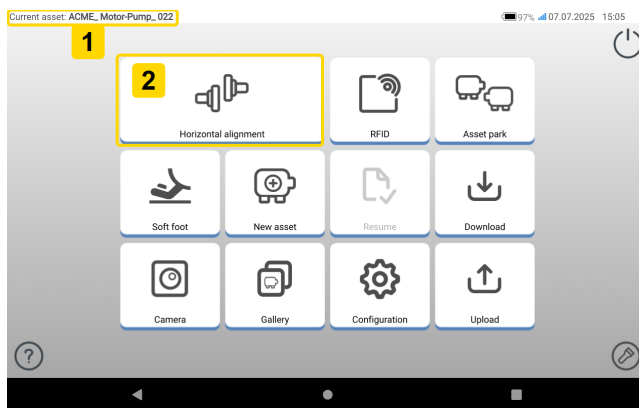

The asset name (1) is shown on the home screen. Tap the shaft alignment icon (2) to start the application.

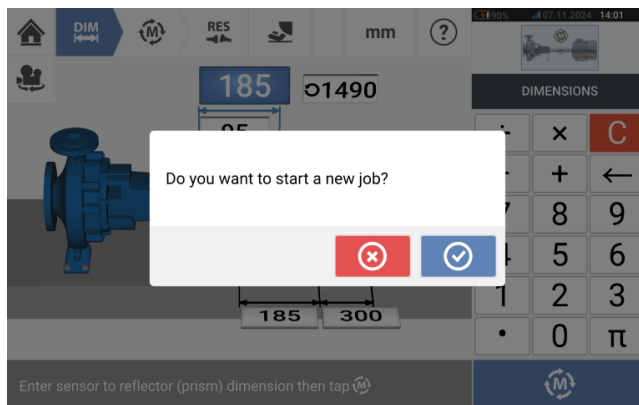
**Note**

If however, no data had been written on the RFID tag, a hint on missing information is shown.

## Using Cloud drive

To set up the PRÜFTECHNIK Cloud drive, an ALIGNMENT RELIABILITY CENTER 4.0 (ARC 4.0) licence is required. The Cloud drive allows the sharing of up-to-date asset measurements from different devices via the PC software ARC 4.0.



**Note**

Wireless connection between the rugged device and a network must be established to enable assets to be transferred via ARC 4.0.

### Transfer an asset to the Cloud drive

After finalizing a measurement save the asset (1) then upload it to Cloud drive.

ASSET LIST	TEMPLATE LIST	LIST OF PDF REPORTS
ASSET ID ^	DATE & TIME ^	STATUS ^
<input type="radio"/> Drainage Pump 223D	11.07.2025 15:14	
<input type="radio"/> Xx22	07.07.2025 15:11	
<input checked="" type="radio"/> ACME_Motor-Pump_022 <b>1</b>	07.07.2025 14:58	

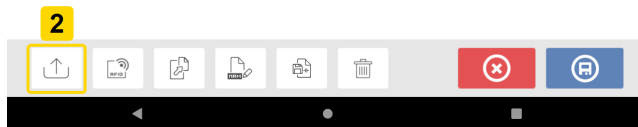

Tap the **Upload** icon (2). The asset appears in ARC 4.0 **Exchange** view with the status **complete**. Drag and drop the asset in its appropriate location on the Cloud drive.

### Download an asset from Cloud drive

From the ARC 4.0 **Exchange** view, drag and drop the desired asset into the Name pane. The asset appears with the status **ready**.

From the touch device home screen, tap the **Download** icon . The selected asset appears in the asset park (1).

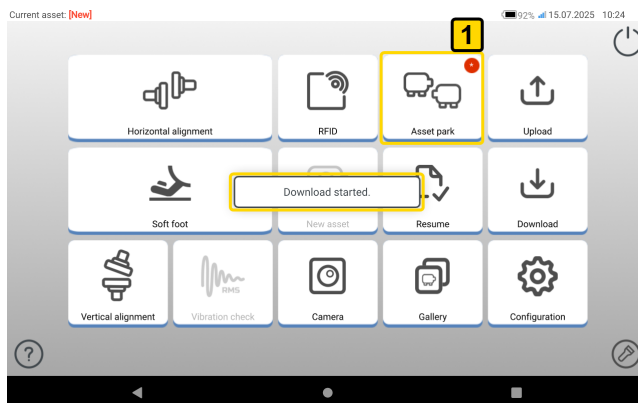

Tap the **Asset park** icon to open the asset in the rugged device.

## Components

The main measuring components for shaft alignment are the rugged device, the sensor and the laser.

### Rugged device



- **1** Power button – used to switch the rugged device on. Press and hold down the power key until the device turns on.
- **2** Ambient light sensor
- **3** Front camera
- **4** USB type C multipurpose connector – used to charge the rugged device or connect the tablet to auxiliary equipment such as a PC
- **5** Rear camera LED flash
- **6** Rear camera

- **7** Location of Near Field Communication (NFC) antenna
- **8** Foldable stand – used to hang device from a railing or lay it down in perfect viewing position
- **9** Protective bumper

Press and hold down the power button (**1**) to switch the device on. Tap and swipe the touch screen to operate the rugged device.

Press and hold down the power button (**1**). These hints are shown on the screen.

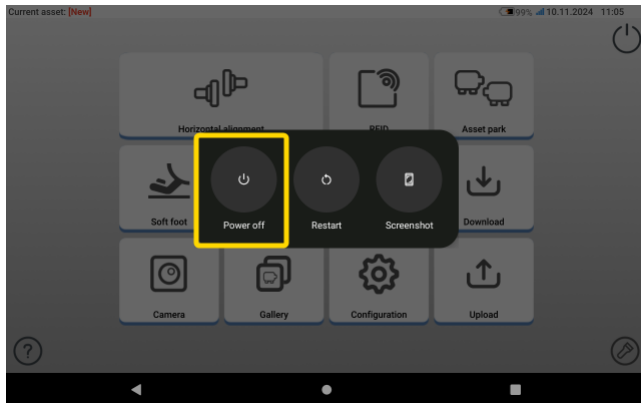

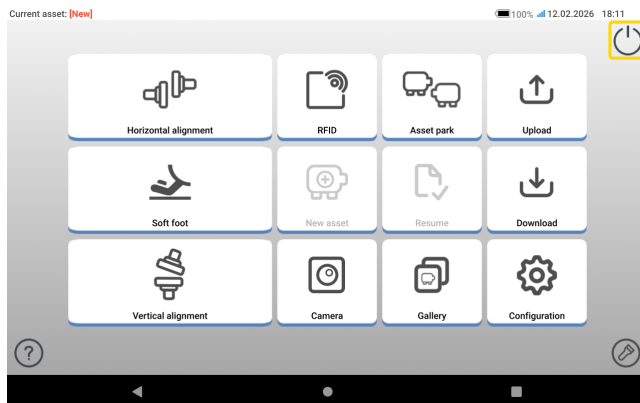

Tap the **Power off** icon to switch the rugged device off.

To exit the Shaft Alignment application, and switch the device to sleep mode, tap the power off icon (  ] shown on the home screen.

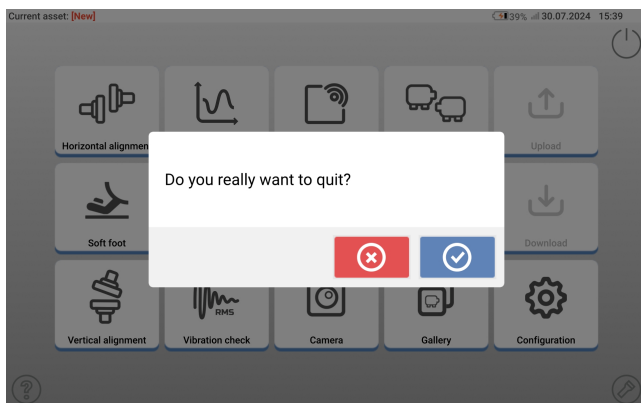

A hint that requires confirmation before the device goes to sleep mode is shown.



Tap  to confirm selection.

## Device interface



The rugged device's multipurpose connector (**4**) is used to charge the device and connect it to a PC. When connected to a PC, data may be transferred from the tablet or a device firmware update may be performed.

## Charge the battery

Charge the battery before using the rugged device for the first time or when the tablet has been unused for extended periods.

Use only the supplied charger and corresponding USB C to USB A cable.

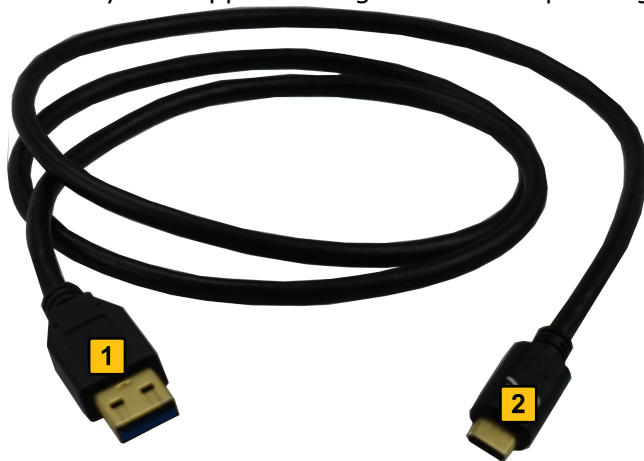

- Connect the standard USB A end (**1**) to the supplied USB charger.
  - Plug the USB C end (**2**) to the rugged device's multipurpose connector.
  - Connect the USB charger to mains supply.
  - When fully charged, disconnect the charger from the rugged device, and then unplug the charger from the mains supply.
- The charge capacity is shown by the power icon (**1**) on the top right corner of the dis-

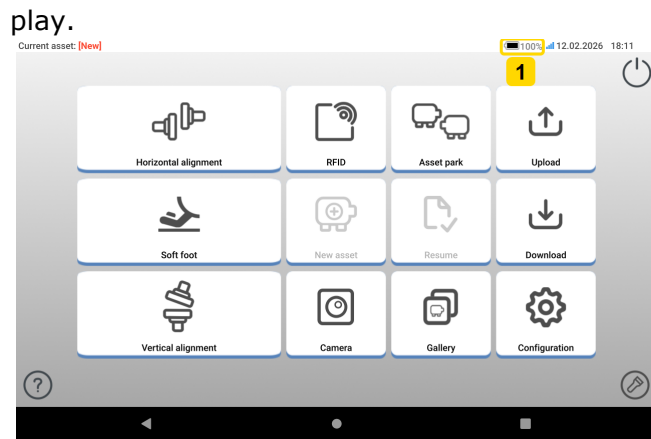

## Core components

### Core laser

The semiconductor laser diode emits a ray of red light (wavelength 630 – 640 nm) which is visible where it strikes a surface. The Class 2 laser beam is emitted with a diameter of approx. 5 mm (3/16”).

Press and hold the On/Off switch briefly to turn the laser on. The battery status LED lights red.



#### WARNING

With the laser on, DO NOT stare into the laser beam!

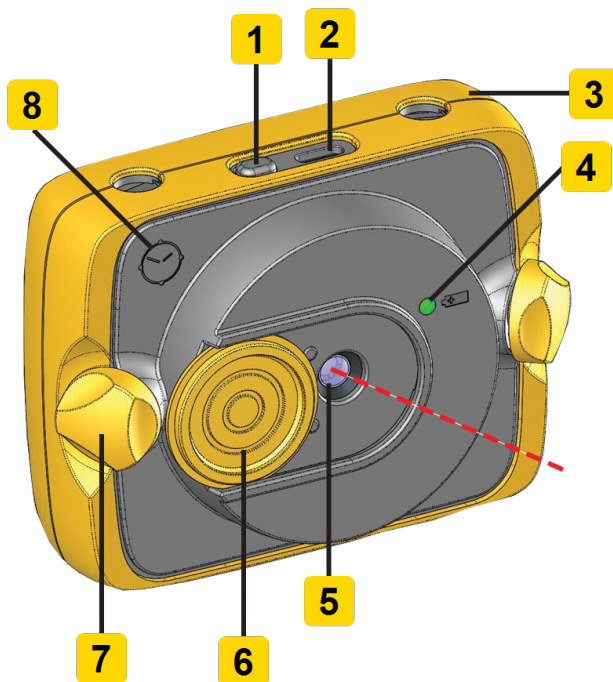

**1:** On/Off push button switch; **2:** USB C port; **3:** Rubber housing; **4:** Battery capacity LED; **5:** Laser emission aperture; **6:** Sliding laser dust cap in open position; **7:** Locking knob; **8:** Reference clock face

The laser beam is fixed. At setup, the laser unit can be moved vertically on the support posts and finely rotated on the shaft to ensure perpendicular incidence on the sensor lens.

The laser is water and dust resistant (IP 65). The internal optics and electronics are internally sealed, preventing possible contamination.

The battery status, rotational angle, temperature, and serial number of the laser unit are transmitted through the laser beam to the sensor. This information is then relayed to the rugged device.

The laser unit is powered by a 3.7 V, 4.7 Wh lithium-ion rechargeable battery, which is attached to the laser unit and must be charged using only the supplied charger/adaptor.



**CAUTION**

As the battery becomes depleted, the color of the battery status LED changes from green (full) to yellow (half full) to red (empty).  
 Make sure the laser unit is fully charged before you start an alignment job. If the laser unit is not in use for a long time, store it in a cool, dry, and well-ventilated area.



**CAUTION**

Do not remove the housing hex head screws under any circumstances. This action will void all warranty coverage.

**Core sensor**

The sensor has built-in Bluetooth. It contains two position detectors that measure the exact position of the laser beam as the shafts rotate. The sensor also has an electronic inclinometer to measure shaft rotation.

Two indicator LEDs are on the front of the sensor. The upper LED shows laser beam adjustment and charging status. It lights red, orange, or green depending on the current function. The lower LED shows Bluetooth communication status. It lights blue when scanning and when communication is established.

The sensor is powered by an internal 3.7 V, 4.7 Wh lithium-ion rechargeable battery.

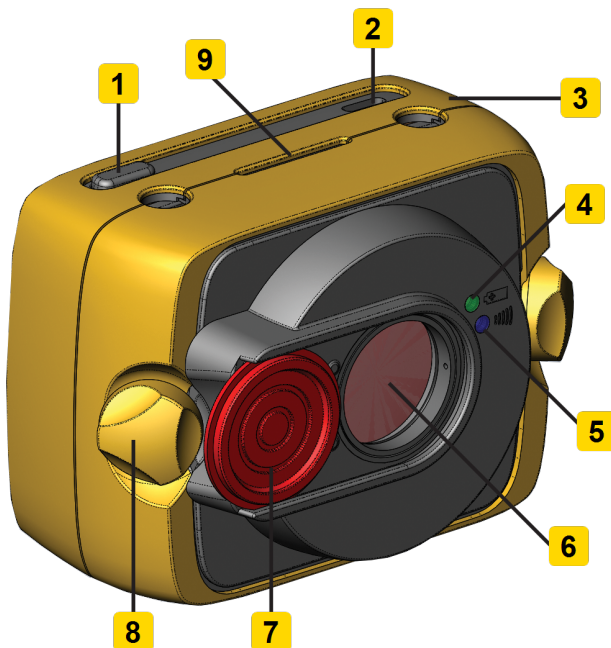

**1:** On/Off push button switch; **2:** USB C port; **3:** Rubber housing; **4:** Laser beam adjustment and charging LED; **5:** Bluetooth communication LED; **6:** Scratch-resistant lens; **7:** Sensor dust cap in open position; **8:** Locking knob; **9:** Distance marking

## Sensor LEDs

Activity	Laser beam adjustment and charging LED	Bluetooth communication LED
Switch on	Lights up red for 1 second, then red or green (depending on the battery capacity) for another second, then continues to blink red	Lights up blue for 1 second then turns off
Laser beam adjustment	Blinks red when laser is OFF Blinks orange when laser is in END position Blinks green when laser centered or in 'laser OK' position	Blinks blue when scanning and when Bluetooth communication is established
Charging	Blinks fast green during fast charge (0% - 90%) Blinks slowly green when charge is > 90% Lights steady green when charge is 100%	

## Charge sensor and/or laser

The sensor and/or laser can be charged via the mains supply or a PC.



### Note

Charging via the mains supply is faster.

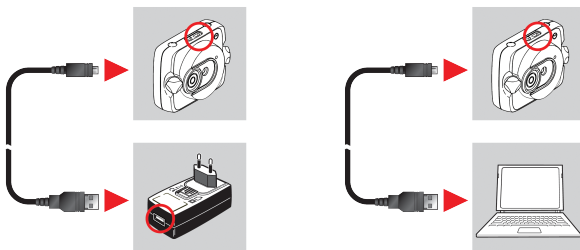

## Open the sensor/laser aperture

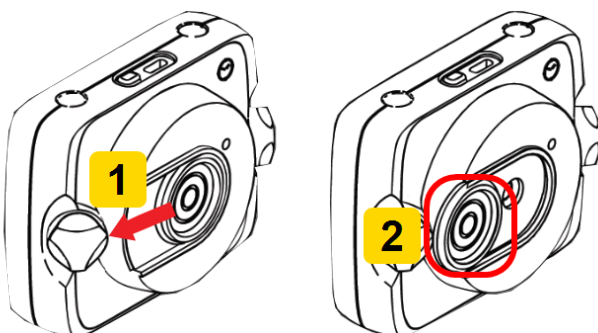

- **(1)** Slide the dust cap in the direction shown by the bold red arrow.
- **(2)** Dust cap in its open position highlighted in red.

## Laser and sensor labels

Labels used to communicate laser safety, radio country approvals, and other general information are affixed to the housings of the system components.

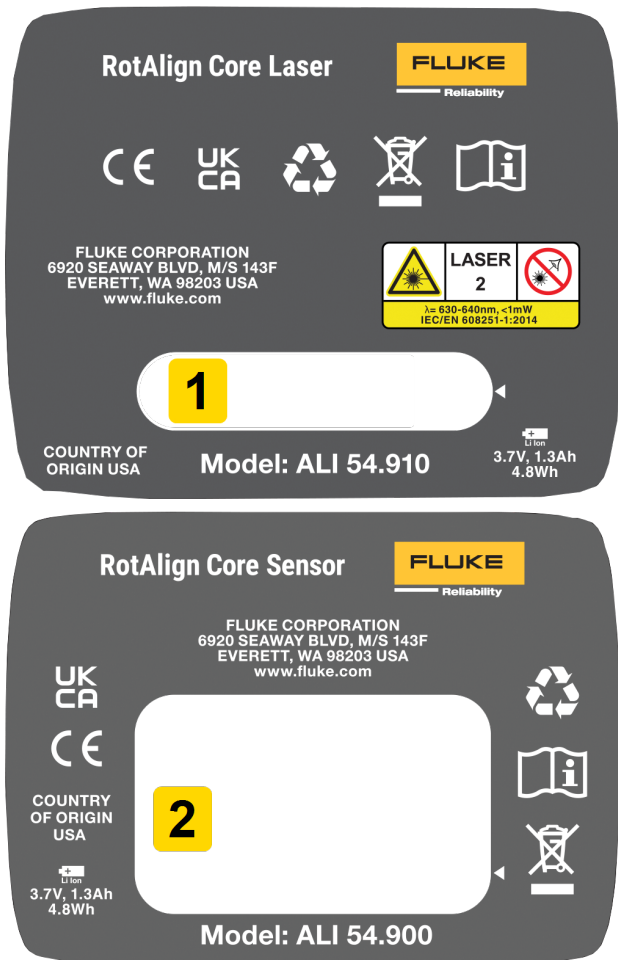

- **(1)** The laser serial number and inspection label are shown here.
- **(2)** The sensor serial number, inspection label and radio country approvals are shown here.

## Mounting components

### Mount brackets



#### Note

The Product is delivered with fully assembled brackets with both the sensor and the laser already assembled. In this case, the bracket holding the laser is mounted on the shaft on the left side of the couplings or the solid coupling hub on the left side (usually stationary machine). The bracket assembly holding the sensor is mounted on the shaft on the right side of the couplings or the solid coupling hub on the right side (usually moveable machine).

Mount the brackets on either side of the coupling on either the shafts or on the solid coupling hubs, and both at the same rotational position.

To get the highest possible measurement accuracy, and to avoid damage to equipment, obey these instructions:



#### CAUTION

Ensure that the brackets fit solidly onto their mounting surfaces! Do not use self-constructed mounting brackets, or modify the original bracket configuration supplied by Fluke (for example, do not use support posts longer than those supplied with the bracket).

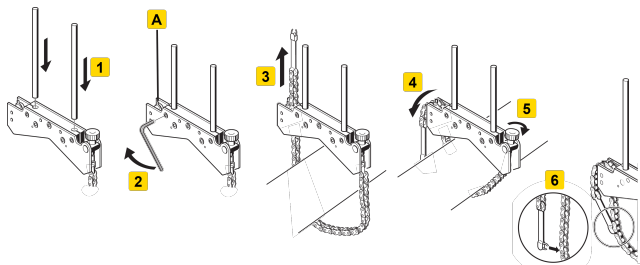

- Choose the shortest support posts which will still allow the laser beam to pass over or through the coupling. Insert the support posts into the bracket..
- Fasten them in place by tightening the hex screws on the sides of the bracket frame.
- Place the bracket on the shaft or coupling, wrap the chain around the shaft and feed it through the other side of the bracket: if the shaft is smaller than the width of the bracket frame, insert the chain from the inside of the bracket as shown in the diagram; if the shaft is larger than the bracket width, insert the chain into the frame from the outside.
- Catch the chain loosely on the anchor peg (**A**).
- Turn the bracket thumbscrew to tighten the assembly onto the shaft.
- Clip the loose end of the chain back onto itself.

The bracket should now be tight upon the shaft. Do not push or pull on the bracket to check, since this could loosen its mounting.

To remove the brackets, loosen the thumbscrew, then remove the chain from its anchor peg.

## Mount sensor and laser

Mount the sensor on the support posts of the bracket fixed on the shaft of the right machine (usually moveable machine), and the laser on the support posts of the bracket fixed on the shaft of the left machine (usually reference machine) – as viewed from normal working position. Before mounting both sensor and laser, make sure these are done:

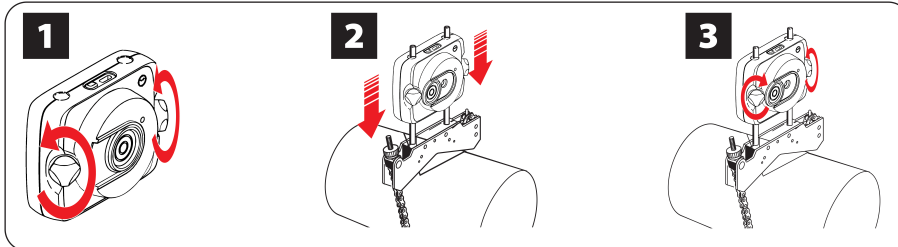

The yellow locking knobs should be loose enough (**1**) to allow the sensor slide onto the support posts (**2**).

Fix both sensor and laser onto their respective support posts. Tighten the yellow locking knobs (**3**).

Ensure that the laser can pass over or through the coupling and is not blocked.

Both sensor and laser should be at the same height, as low as possible, yet just high enough for the beam to clear the coupling flange. They should also visually appear to be rotationally aligned to each other.

Make the final adjustments; loosen the brackets slightly if necessary, then rotate them and tighten them again.

## Dimensions

From the home screen, tap  the horizontal alignment icon to access the dimensions screen.

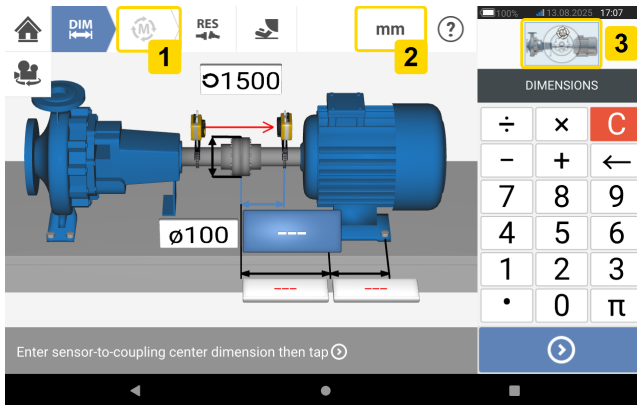

- **(1)** Grayed out icons are disabled within the active screen. The **Measure** icon is enabled after all dimensions have been entered.
- **(2)** Tap the measurement units icon **mm** to set necessary units. The icon toggles between **inch** and **mm**.
- **(3)** Tap the slider on the mini train icon to open the triple **Train Manager / Train Setup / Train Fixation** screen.  
**Note:** See section on train setup and fixation for details. Train Manager is described in machine train alignment.

Tap the dimension fields and enter all required dimensions. Alternatively, tap  to proceed to enter next dimension. Dimensions are entered only when the dimension field is highlighted blue.



### Note

If units are set to Imperial system, inch fractions may be entered as follows: For  $1/8$ " enter  $1/8 = 0.125$ "; For  $10 \frac{3}{8}$ " enter  $10 + 3/8 = 10.375$ ".  
 The coupling diameter value may be determined by entering the measured circumference of the coupling and dividing the value by  $\pi$  ( $\pi$ ) ( $= 3.142$ ). For example  $33"/\pi = 10.5$ "; Or  $330 \text{ mm}/\pi = 105 \text{ mm}$

The rotate machine view icon  is used to rotate the view of the machines and mounted components on the display.

Machine and coupling properties are edited when the related machine or coupling is tapped.

When all required dimensions have been entered, the **Measure** icon  is shown.

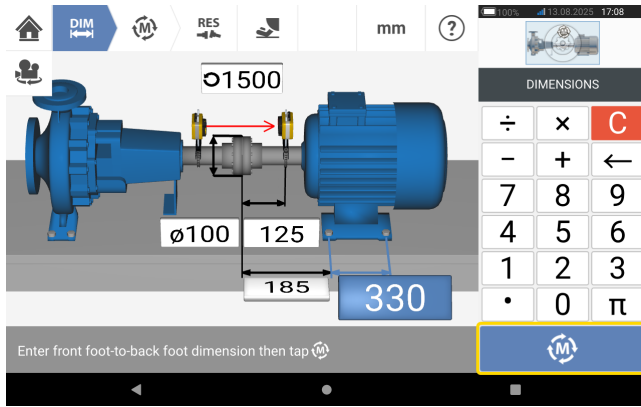



Tap  to proceed with measurement.

### Train setup and fixation

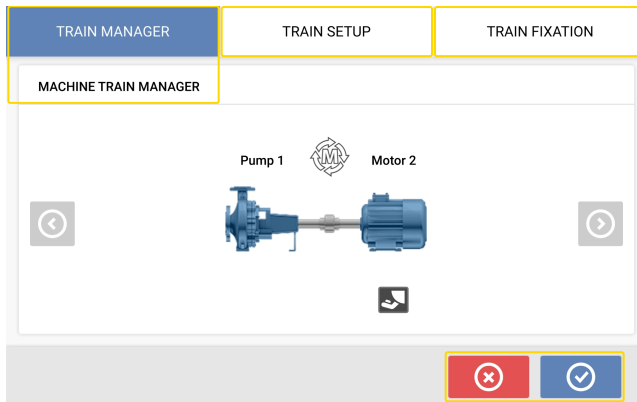
The mini train icon with slider is available in the dimensions, measure and results screens. Tap the slider to open the triple **Train Manager / Train Setup / Train Fixation** screen.



Tap either **TRAIN SETUP** or **TRAIN FIXATION** to open related screen. Alternatively, tap either  or  to return to previous screen.

If **TRAIN SETUP** is selected, the machine train setup screen can be used to select necessary machine and coupling types. Machinery color can also be selected.

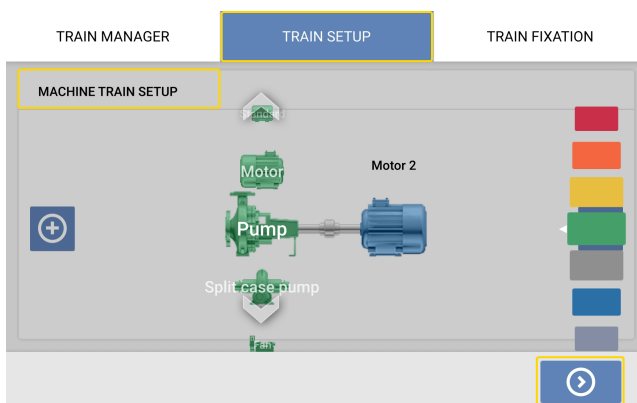

Tap machine or coupling to be specified. If a machine is selected, both machine and color carousels appear. If coupling is selected, only the coupling carousel appears. Use the carousels to specify machine or coupling type, and the machine color. Only one element can specified at a time. After an element has been defined, tap  then proceed to select the next

element. When all machine train elements have been defined, tap  to return to the screen from where the triple **Train Manager / Train Setup / Train Fixation** screen was initially opened.

If **TRAIN FIXATION** is selected, the machine train fixation screen can be used to fix and unfix machine feet pairs or entire machine. This solves machine bolt-bound problems.

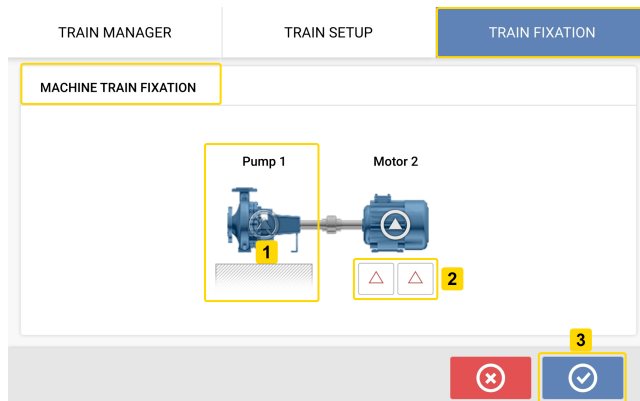

In this example, the pump has no feet (**1**) and is permanently fixed. The motor feet pairs (**2**) are unfixed and therefore movable. Tap  (**3**) to return to the screen from where the triple **Train Manager / Train Setup / Train Fixation** screen was initially opened.

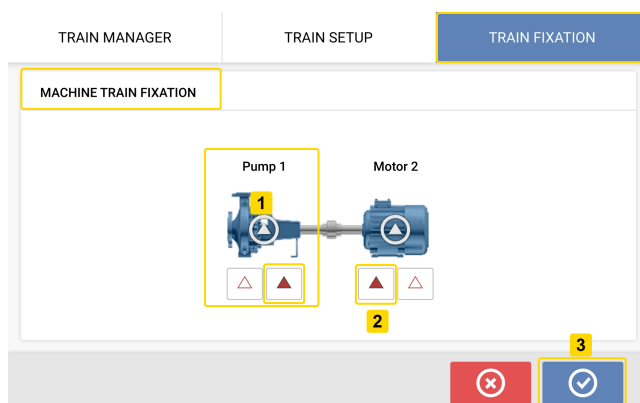

To make a machine permanently fixed, tap the symbol (**1**) at the center of the machine. To undo this action, tap the symbol (**1**) again. When a machine is unfixed feet are shown. To fix any machine feet pair tap the necessary feet pair. Fixed feet pairs are shown marked red (**2**).

If feet pair are redefined, then machine dimensions must be adjusted. Tap  to open the dimensions screen and enter necessary dimensions.

## Machine properties

These lifelike machine graphics are available:

1. Generic standard machine;
2. Motor;
3. Pump;
4. Split case pump;
5. Fan;
6. Center hung fan;
7. Blower;
8. Compressor;
9. Gearbox;
10. Rotor gearbox;
11. Diesel engine;
12. Generator;
13. Gas turbine;
14. Shaft with no supports;
15. Shaft with a single support;
16. Shaft with two supports

From the dimensions screen, tap the machine to show the respective machine carousel.

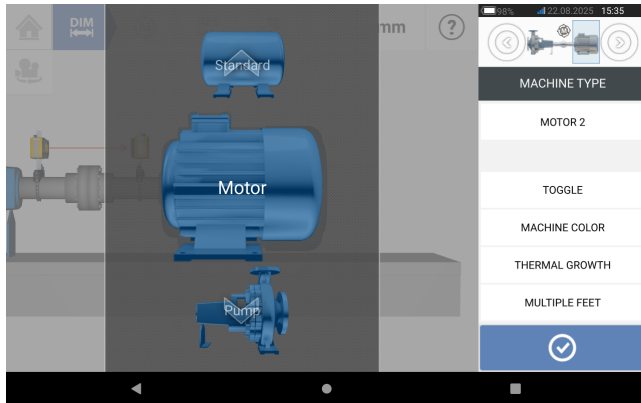

Swipe the machine carousel up or down and select necessary machine. Position necessary machine at the centre of the carousel then tap  to confirm selection and return to the dimensions screen.

## Toggle

**Toggle** is used change the orientation of the selected machine along the shaft axes. In the next example, the motor has been flipped so as to connect the non-drive side to the coupling.

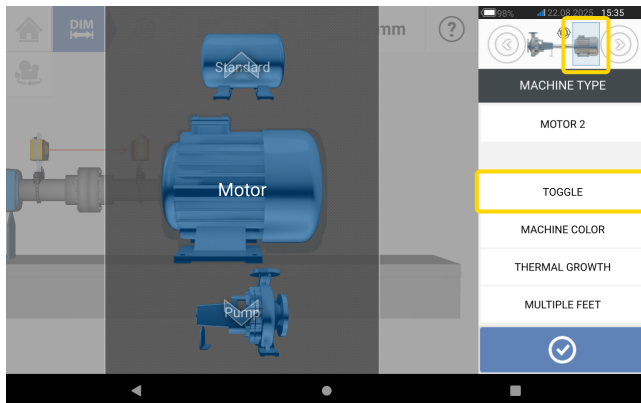

## Machine colour

Tap **Machine Color** to select the necessary machine colour. A colour palette is shown.

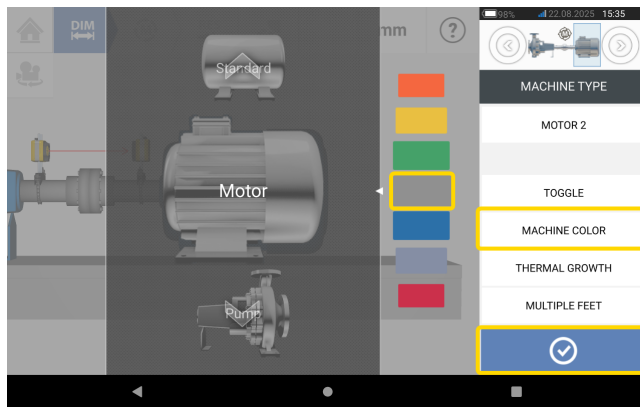

Swipe the colour palette up or down to select the necessary colour then tap  to confirm selection and return to the dimensions. The machines now have the correct colour.

## Thermal growth

Thermal growth is the movement of shaft centerlines associated with or due to a change in machinery temperature between the idle and operating conditions.

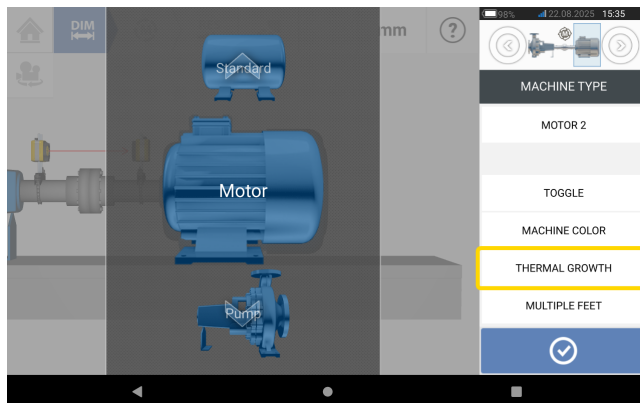

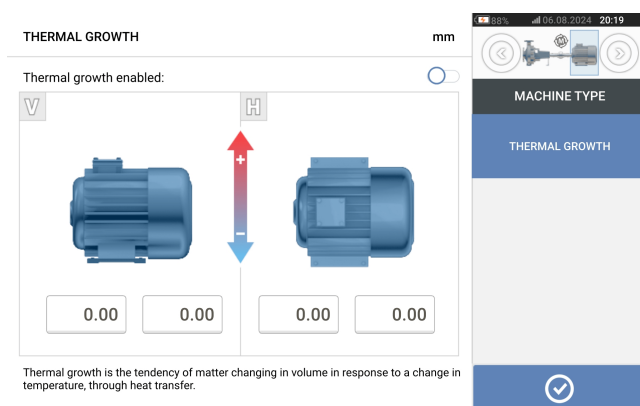

With machine carousel shown, tap the item **Thermal Growth**. The thermal growth screen is shown.

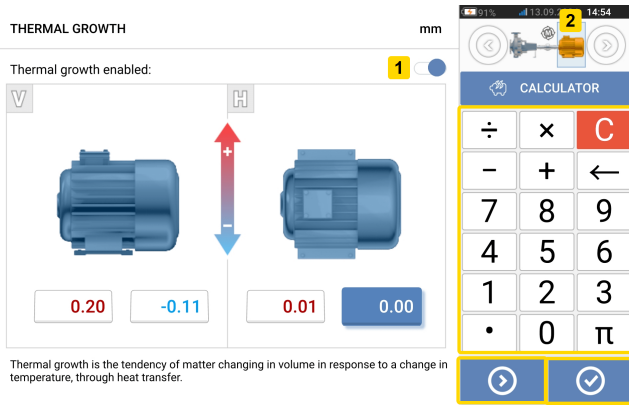

Thermal growth values can be entered only when machine feet have been defined.

To enter any specified thermal growth value at the required foot position, tap the related value box then proceed to enter the thermal growth value. Use the onscreen keyboard. Cycle through the value boxes using . Alternatively, tap the necessary foot position.



Tap or swipe the icon  to the right (1). Thermal growth values are switched on. When thermal growth values are on, the related machine within the mini train inset at the top-right corner is shown in orange (2). After thermal growth values have been entered, tap  to proceed.

### Thermal growth calculator

The calculator is used to calculate thermal growth compensation if no other values are available. Thermal growth is calculated from the material coefficient of linear thermal expansion, expected temperature difference and length of the shaft centerline from the shim plane.

With the thermal growth screen shown, tap value box of feet pair (1) where thermal growth is to be entered.

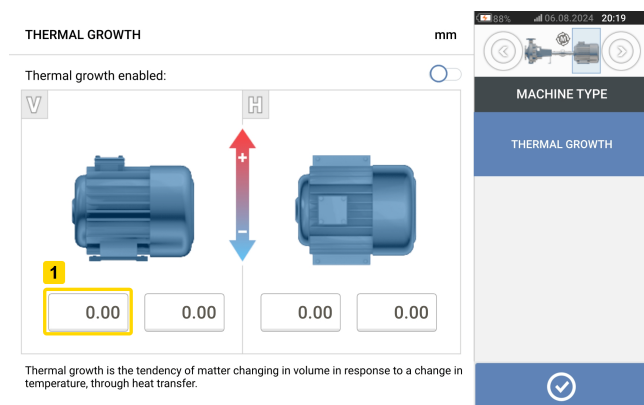

The box is highlighted (2), and the **Calculator** tab (3) is shown.

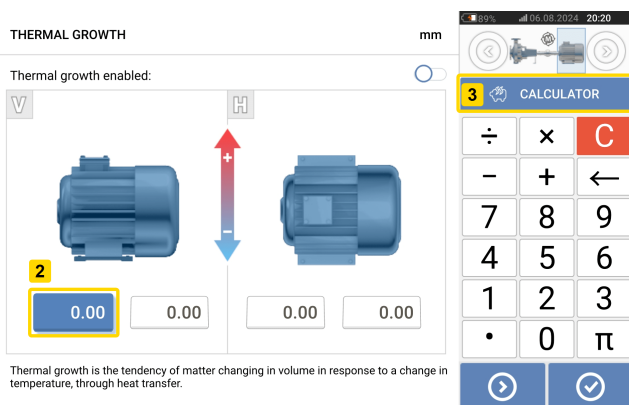

Tap **Calculator** tab (3) to open the thermal growth calculator screen.

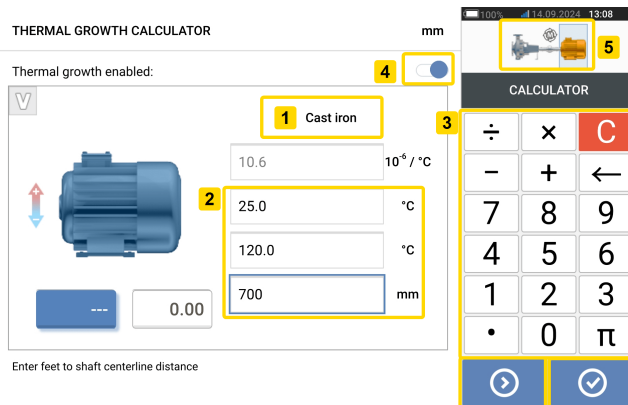



Tap **(1)** and select machine material. The related linear thermal expansion is shown. Enter the three values **(2)** necessary to calculate the thermal growth value for the selected feet pair. Use the onscreen keyboard **(3)**. The three values are:

- Ambient temperature (initial temperature)
- Machine running temperature (final temperature)
- Distance from machine base (or shimming plane) to the shaft centerline (length)

With thermal growth values on **(4)**, the related machine within the mini train inset at the top-right corner appears in orange **(5)**.

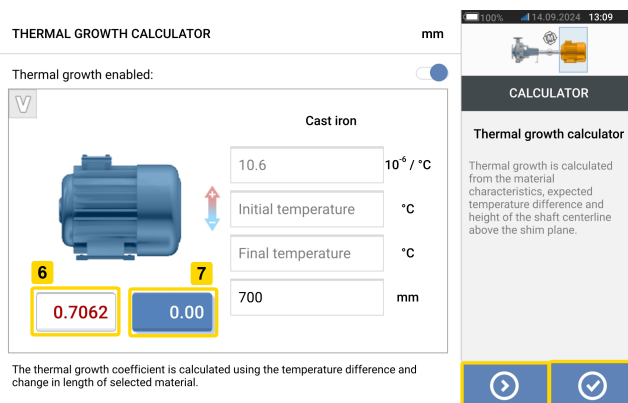
Tap  to simultaneously show the calculated thermal growth value for the related feet pair **(6)** and toggle to the next feet pair **(7)**.



Tap  to return to the thermal growth.

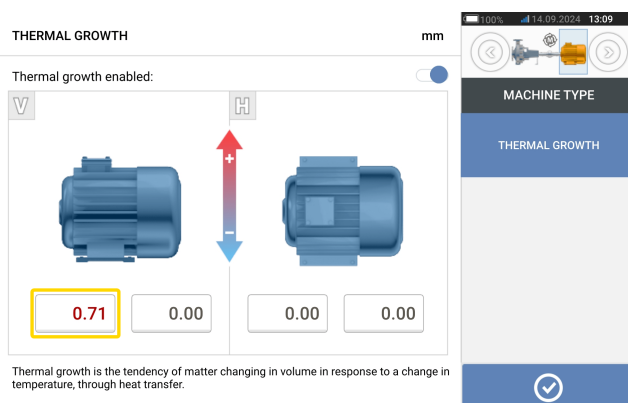

## Multiple feet

The item **Multiple feet** is used to determine foot corrections in a multiple feet machine, and is therefore available also in the result screen.

The dimension between the feet is defined in the multiple feet screen. Tap **Multiple feet** to show the screen.

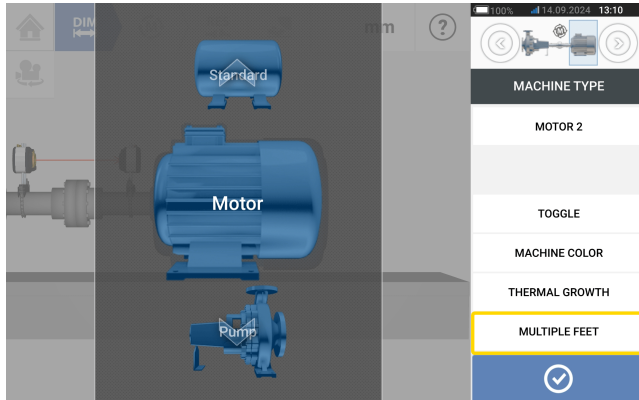

If the dimension between the front feet and the back feet (**1**) has already been entered, it will be shown in the multiple feet screen.

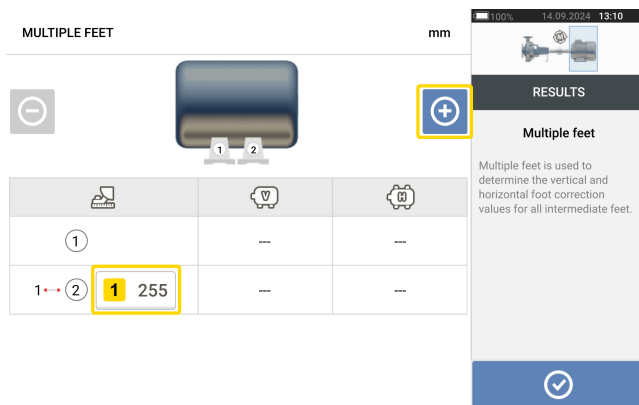



### Note

The intermediate machine feet are not displayed in the dimension screen.

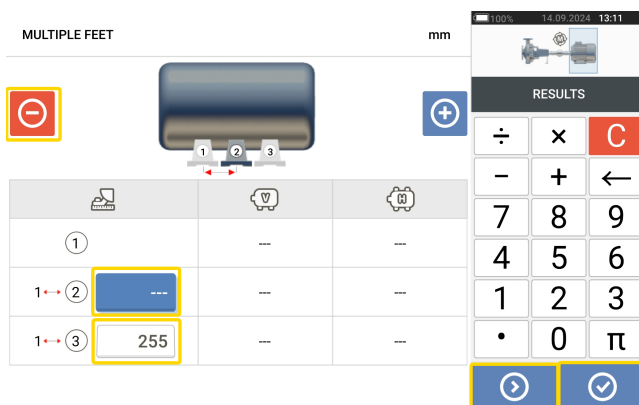
Tap  to add any intermediate feet.



- The intermediate feet pair is added after the front feet.
- Enter this dimension in the row that appears.
- Tap  to delete intermediate feet, if necessary.
- Tap  to exit the multiple feet screen.

## Coupling properties

From the dimensions screen, tap coupling to access coupling carousel.

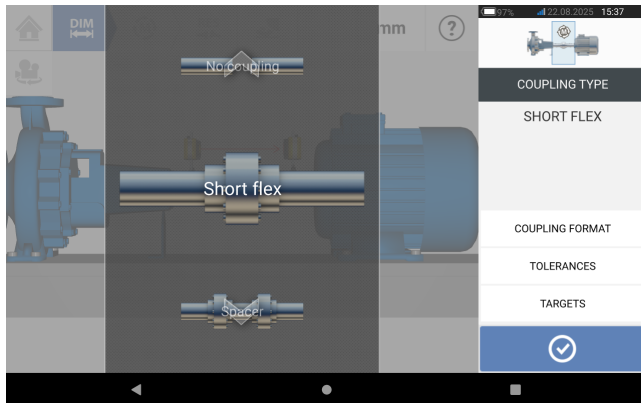

Swipe the carousel up or down and select necessary coupling type. These coupling types are available for selection:

- Short flex — These couplings feature fitted transmission elements with play (such as teeth, claws or bolts) or elastic connecting elements like rubber 'tires' or springs.
- Spacer shaft — When the coupling halves are joined by a spacer element, its length must be entered.
- Single plane — The coupling halves are bolted directly together. Loosen the bolts before taking measurements, since they would otherwise distort the true alignment condition.
- No coupling — This coupling format is intended for use with CNC machines. In this format, the length between the two shafts must be entered. The measurement mode for this coupling format is IntelliPoint.

## Targets

Targets are misalignment values specified as an offset and an angle in two perpendicular planes ( horizontal and vertical) and used to compensate for dynamic loads.

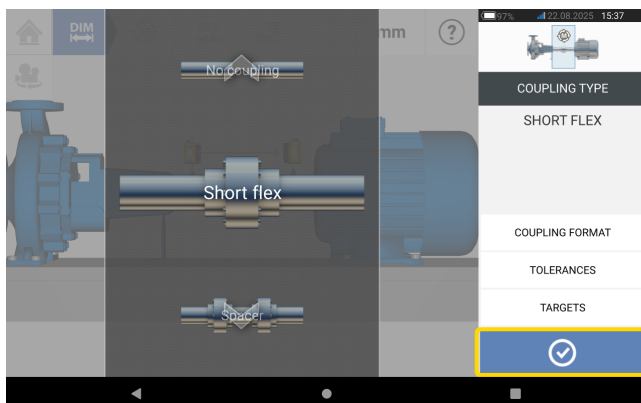

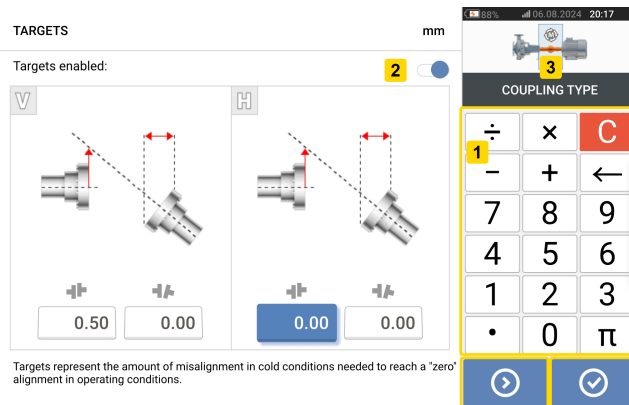

With coupling carousel shown, tap the item **Targets** to open the coupling targets screen.



The shown coupling format depends on the type of coupling selected.

To enter any target specifications at the coupling, tap the related value box then proceed to enter the target value. Use the onscreen keyboard (1) which comes into view when any one of the four value boxes is tapped. Use  to cycle through the value boxes. Alternatively, tap the necessary value box.

Tap  (2) to activate target specification values. When target values are enabled, the coupling (3) within the mini train inset at the top-right corner appears in orange. After target values have been entered, tap  to proceed.

## Tolerances

Alignment quality is evaluated through comparison with tolerances based upon entered machine dimensions and RPM.

The tolerance ranges are compiled as tables according to type of coupling, coupling format, and diameter (for the gap value) as well as RPM. When the coupling type is spacer, the tolerance table values are determined by the length of the spacer shaft and the RPM.

Tolerances are accessed via the dimensions screen.

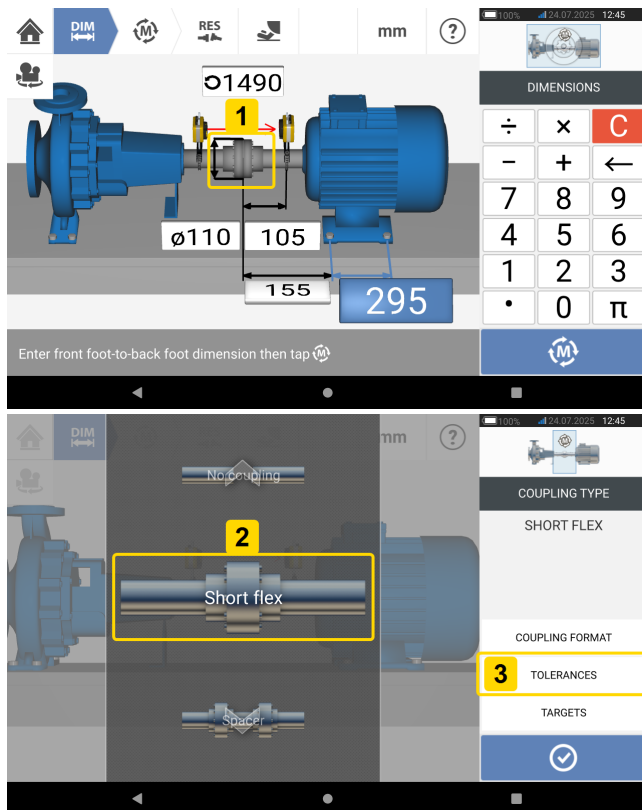

Tap the coupling (1), then use the carousel that appears to select the necessary coupling type (2). Tap **TOLERANCES** (3) to access the coupling tolerance table.

### Available tolerance tables

The available tolerance tables are based on machine operating frequency.

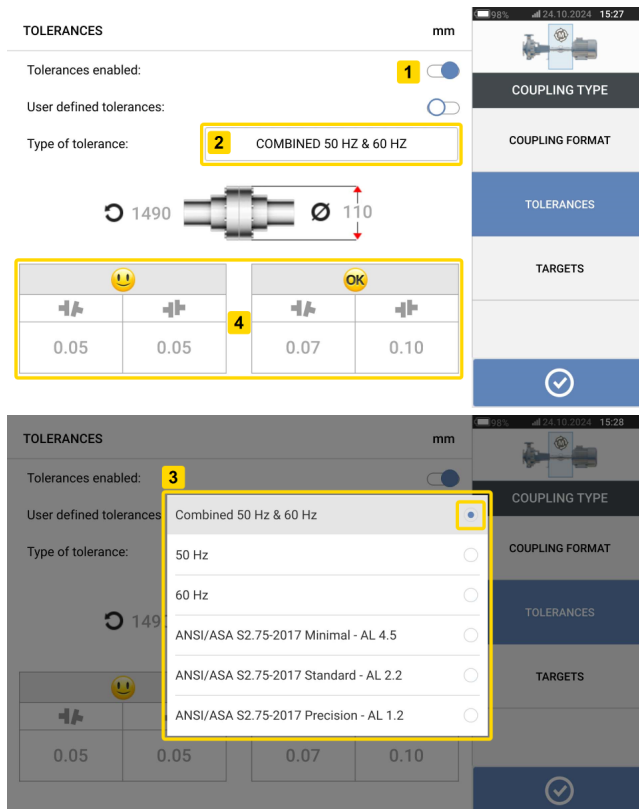

Swipe the icon (1) to the right to enable tolerances. Tap (2) to select wanted type of tolerance. A pop-up menu (3) with available tolerances is shown. Tap necessary type to show the related tolerance table (4).

## ANSI standard specification tolerances

The Acoustical Society of America (ASA) developed shaft alignment tolerances for both short flex and spacer couplings on standard rotating machinery. These tolerances are an approved American National Standards Institute (ANSI) specification, and are grouped into three tiers (minimal, standard and precision).

## User defined tolerances

The image displays two screenshots of a mobile application interface for setting tolerances. The top screenshot shows the 'TOLERANCES' section with 'Tolerances enabled' and 'User defined tolerances' toggles. The 'Asymmetric tolerances' toggle (2) is highlighted. Below it, a technical drawing of a coupling is shown with dimensions 1490 and 110. A table below the drawing shows two tolerance input fields (3) both set to 0.00. The bottom screenshot shows the same interface, but the 'Asymmetric tolerances' toggle is now turned on. The tolerance input fields (5) are now set to 0.02 and 0.08. An onscreen keyboard (4) is displayed over the input fields, showing a numeric keypad with a red 'C' button for clearing.

Swipe the icon (1) to the right to enable user defined tolerances. Asymmetric tolerances (2) can be activated only when user defined tolerances are enabled. In asymmetric tolerances, the tolerance values for the two coupling planes are not the same. Tap (3) to edit user defined tolerances using the onscreen keyboard (4). The edited values are then shown (5).

## Asymmetric and symmetric tolerances

The image displays two screenshots of a mobile application interface for setting tolerances on a mechanical part. The part is a shaft with a diameter of 110 mm and a length of 1490 mm.

**Top Screenshot (Asymmetric tolerances disabled):**

- TOLERANCES:** mm
- Tolerances enabled:
- User defined tolerances:
- Asymmetric tolerances:  (labeled **1**)
- The tolerance table (labeled **2**) shows symmetric tolerances: 0.02 for both horizontal and vertical planes.

**Bottom Screenshot (Asymmetric tolerances enabled):**

- TOLERANCES:** mm
- Tolerances enabled:
- User defined tolerances:
- Asymmetric tolerances:  (labeled **3**)
- The tolerance table (labeled **4**) shows asymmetric tolerances: 0.00 for horizontal and 0.08 for vertical.

When asymmetric tolerances have not been enabled (**1**), the shown specified tolerances (**2**) are symmetric. The gap and offset tolerances for both horizontal and vertical planes are identical.

If asymmetric tolerances are enabled (**3**) all four specified values are shown (**4**).

## Tolerance table based on coupling format

**TOLERANCES** mm

Tolerances enabled:

User defined tolerances:

Type of tolerance: COMBINED 50 HZ & 60 HZ



<b>1</b>		<b>OK</b>	
0.05	0.05	0.07	0.10

98% 24.10.2024 15:27

COUPLING TYPE

**3** COUPLING FORMAT

TOLERANCES

TARGETS

✓

  

**TOLERANCES** mm | °

Tolerances enabled:

User defined tolerances:

Type of tolerance: COMBINED 50 HZ & 60 HZ



<b>2</b>		<b>OK</b>	
0.03	0.05	0.04	0.10

97% 24.10.2024 15:35

COUPLING TYPE

**3** COUPLING FORMAT

TOLERANCES

TARGETS

✓

For the same type of tolerance, RPM, and coupling diameter, the tolerances value differ according to the coupling format selected. Coupling format **(1)** is gap/offset for short flex coupling, and **(2)** is angle/offset for short flex coupling. Tap **COUPLING FORMAT (3)** to change format.



**Note**

There are no tolerance tables for consolidated spacer shaft coupling formats. Consolidated formats consider the spoolpiece or jackshaft as an extension of either the right or left shaft.

## Suggested consolidated shaft alignment tolerances

The following table shows the consolidated (50 Hz and 60 Hz) tolerances

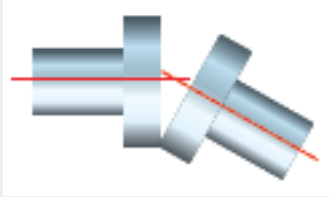
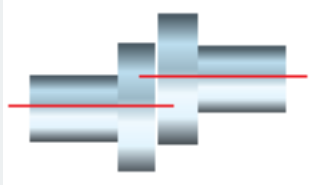
	RPM	metric (mm)		imperial (mils)	
		Acceptable OK	Excellent 😊	Acceptable OK	Excellent 😊
<b>Short flexible couplings</b> Gap (per 100 mm or 10" diameter) 	600	0.15	0.10	14.9	10.0
	750	0.12	0.08	12.3	8.2
	900	0.10	0.07	10.5	7.0
	1000	0.10	0.06	9.6	6.4
	1200	0.08	0.05	8.2	5.4
	1500	0.07	0.04	6.7	4.5
	1800	0.06	0.04	5.7	3.8
	3000	0.04	0.02	3.7	2.5
	3600	0.03	0.02	3.1	2.1
	6000	0.02	0.01	2.0	1.3
	7200	0.02	0.01	1.7	1.1
<b>Offset</b> 	600	0.23	0.13	9.0	5.1
	750	0.18	0.10	7.3	4.1
	900	0.16	0.09	6.1	3.4
	1000	0.14	0.08	5.5	3.1
	1200	0.12	0.07	4.6	2.6
	1500	0.09	0.05	3.7	2.1
	1800	0.08	0.04	3.1	1.8
	3000	0.05	0.03	1.9	1.1
	3600	0.04	0.02	1.6	0.9
	6000	0.02	0.01	1.0	0.6
	7200	0.02	0.01	0.8	0.5

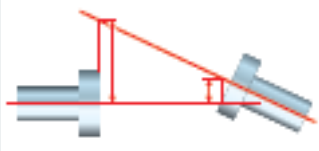
	RPM	metric (mm)		imperial (mils)	
		Acceptable OK	Excellent 😊	Acceptable OK	Excellent 😊
<b>Spacer shaft and membrane (disk) couplings</b> Offset (per 100 mm spacer length or per 1" of spacer length) 	600	0.30	0.18	3.0	1.8
	750	0.24	0.14	2.4	1.4
	900	0.20	0.12	2.0	1.2
	1000	0.18	0.11	1.8	1.1
	1200	0.15	0.09	1.5	0.9
	1500	0.12	0.07	1.2	0.7
	1800	0.10	0.06	1.0	0.6
	3000	0.06	0.04	0.6	0.4
	3600	0.05	0.03	0.5	0.3
	6000	0.03	0.02	0.3	0.2
	7200	0.02	0.01	0.2	0.1

## Laser beam adjustment

### Laser adjustment wizard

The laser adjustment wizard is the primary laser beam adjustment feature in the rugged tablet. If the sensor is initialized, and the laser beam is not centered, use the wizard to adjust the laser beam correctly. The wizard arrows indicate the direction and amount in which movement should take place.



- The wizard arrows (1) and (2) show the direction and magnitude in which the laser is to be moved in order to adjust the laser beam correctly.
- The attained laser beam status is shown in 3.
- 4 shows the position of the laser beam on the position detector.
- The wizard arrows decrease in magnitude and occurrence as the laser beam status improves, disappearing completely once the laser beam is centered.
- Measurement can commence when the laser beam is centered.

If it is necessary to adjust the laser beam without the wizard, see related topics.

## Laser beam adjustment (Core)

### Core laser and sensor

1. Slide the dust cap (1) to the open position to open the laser aperture. Press the On/Off push button switch (2) to turn the laser on. Leave the sensor dust cap in the closed position.

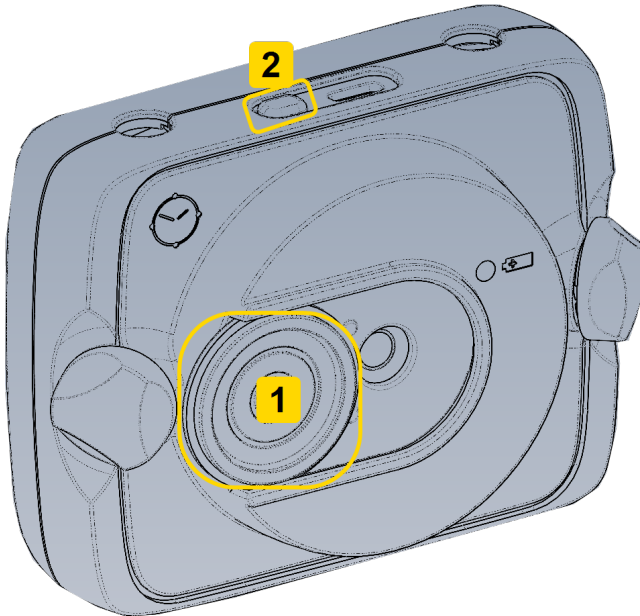

#### **WARNING**

Do not stare into the laser beam!

2. If the laser and sensor have been roughly positioned to each other during mounting, the laser beam should strike the sensor dust cap. If the beam be so far off target that it misses the sensor completely, hold a sheet of paper in front of the sensor to locate the beam and readjust it onto the sensor as follows:

3. Reposition the components until the laser beam strikes the sensor cap:

- vertically: loosen the locking knobs and adjust the height.
- horizontally: loosen the bracket and turn the laser and/or sensor brackets into line with one another. Make sure both brackets are rotationally aligned to each other.

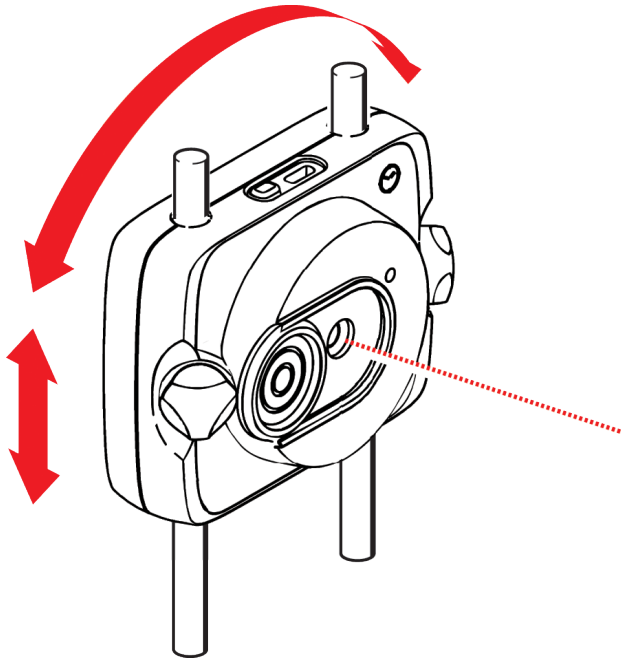

4. Make further horizontal and vertical adjustment until the laser beam strikes the center of the sensor dust cap. Slide the dust cap to the open position to open the sensor aperture.

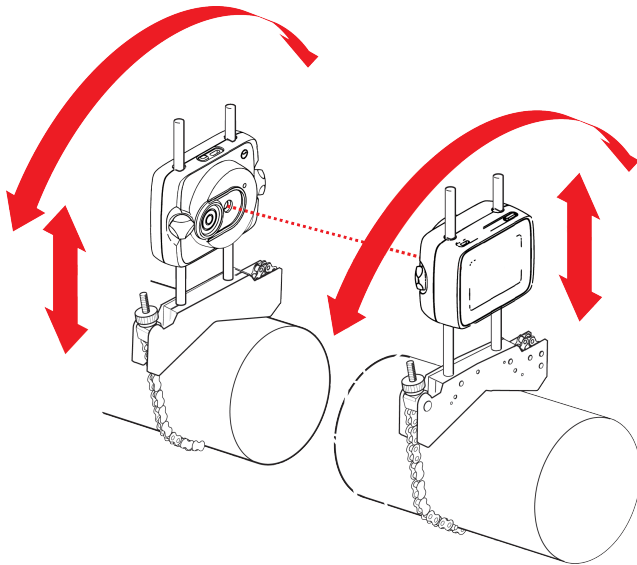

## XY View

Use the XY View function to center the laser beam on the position detector before measurement.

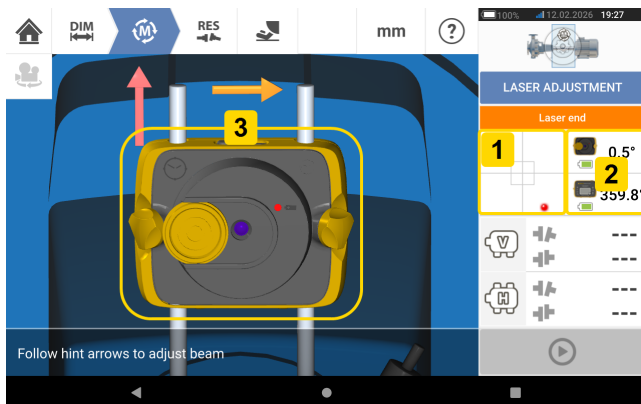

- Tap the shown detector area (1) to directly access the XY View screen.
- Tap the **sensor/laser** area (2). Select the menu item **XY View** to open the XY View screen.
- Tap the laser (3). Select the menu item **XY View** to open the XY View screen.

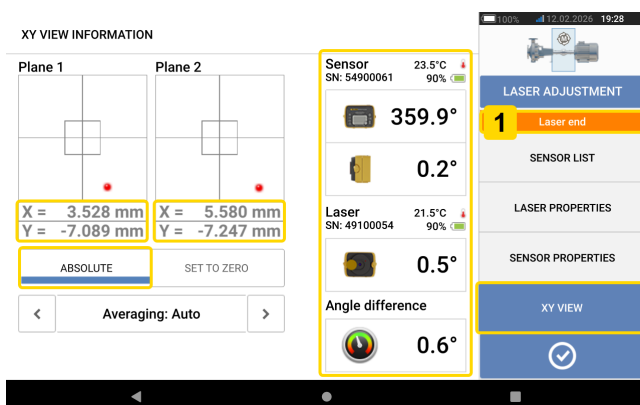

The **XY View Information** screen shows: the absolute X,Y coordinates of the laser beam on the position detector; the angle of the sensor and laser on the shafts; sensor vertical angle; serial numbers of both laser and sensor.

For RotAlign Core, loosen the laser locking knobs and adjust its height along the support posts. Then, loosen the laser bracket and rotate it to center the laser beam dot. In some cases it may be necessary to move the sensor along the support posts or sideways. Loosen the chain type bracket and rotate it slightly.

The **Set to zero** function is used to check the effect of environmental and machinery vibration on the measurement.

**Note:** **Set to zero** is active only when the laser beam status (1) is **OK** or **Centered**.

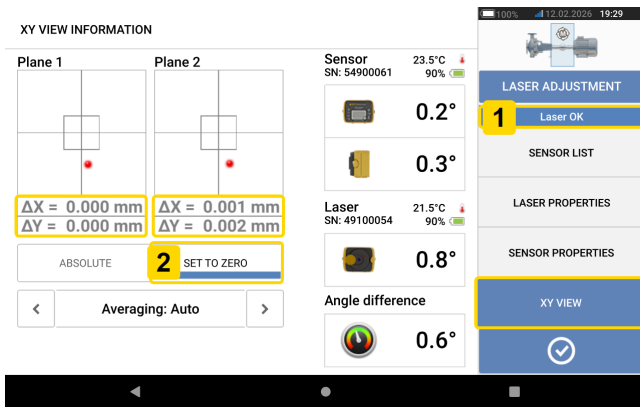

If the laser beam status is **OK** or **Centered** (1), tap **Set to zero** (2) to set the current laser dot position as 0,0. The  $\Delta X, \Delta Y$  values are then monitored to check the stability of the values. Tap **Absolute** to go back to the accurate values.

**Note:** The menu items on the screen are used to show these items:

Sensor list – shows serial number of sensors detected or previously used, as well as type of connection used for communication.

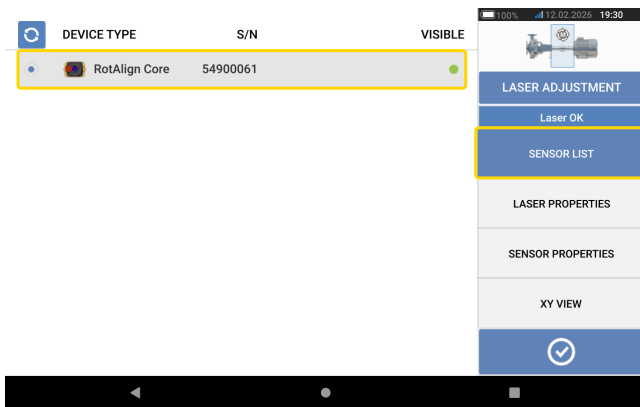

Laser properties – shows detailed information of the laser unit in use

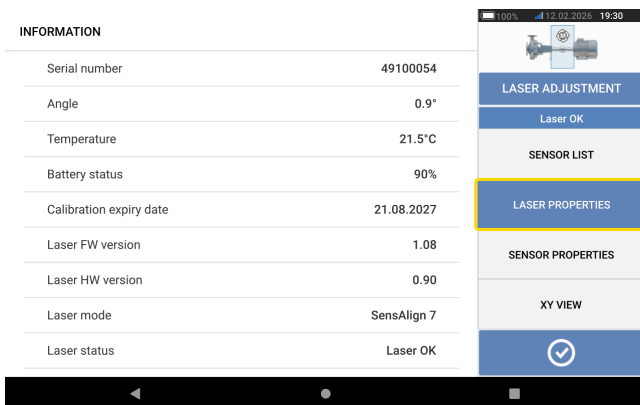

Sensor properties – shows detailed information of the sensor unit in use

INFORMATION	
Serial number	54900061
Angle	0.2°
Temperature	23.5°C
Battery status	90%
Calibration expiry date	21.08.2027
Sensor FW version	1.1.0.106
Sensor HW version	0
Laser status	Laser OK
Licenses	---

The image shows a mobile application interface with a menu on the right side. The menu items are: LASER ADJUSTMENT, Laser OK, SENSOR LIST, LASER PROPERTIES, SENSOR PROPERTIES (highlighted with a yellow border), XY VIEW, and a confirmation button with a checkmark icon. The top status bar shows 100% battery, signal strength, and the date 12.02.2024 at 19:30.

## Initializing sensor

The hint **Communication error** (1) suggests that the sensor has not been initialized although the laser beam may have been correctly adjusted.

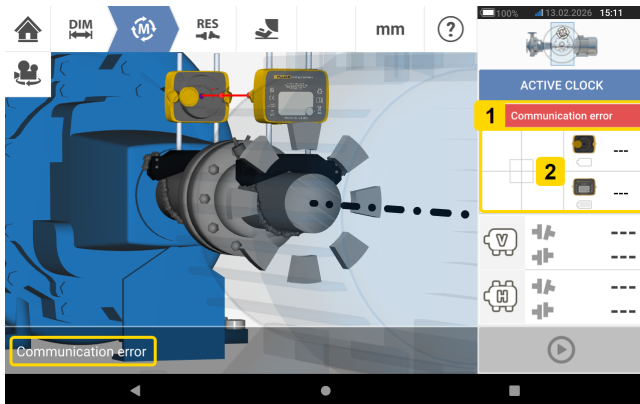

Tap the detector and sensor/laser area (2) to open the menu item **SENSOR LIST**.

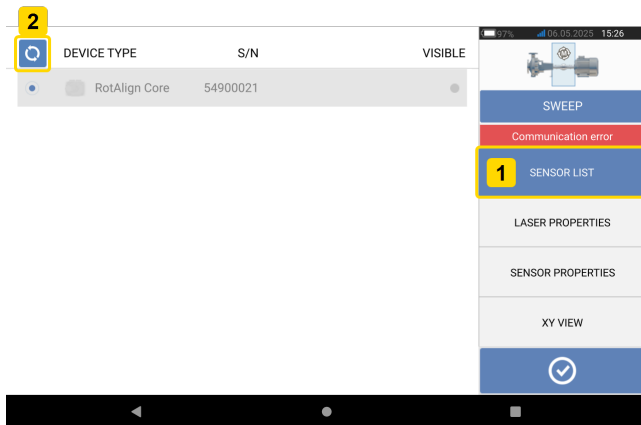

Tap menu item **SENSOR LIST** (1) to see listed sensors. Tap  (2) to scan for the sensor. The hint **Scanning for sensor(s)** is shown during the scan process.

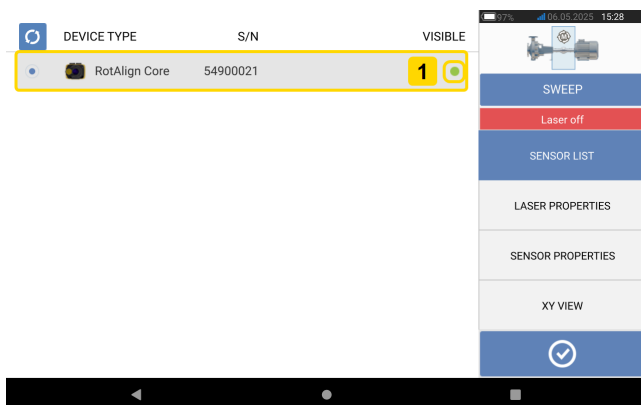

As soon as the sensor is detected, it is shown bold with a green bold dot (1) next to the detected sensor. Tap the listed sensor to initialize it.

## Measurement

The necessary measurement mode is selected from the measurement screen.

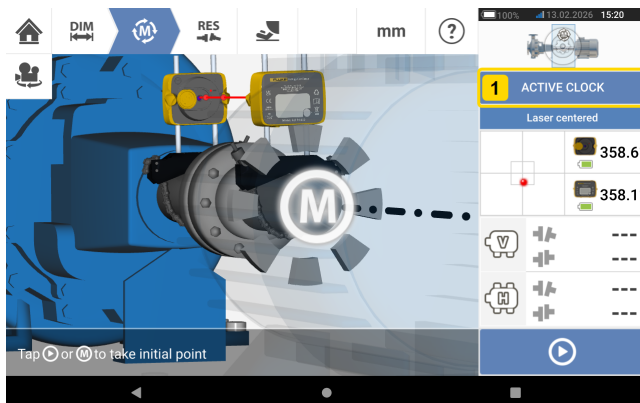

Tap the measurement mode header (1) to open the measurement mode carousel.

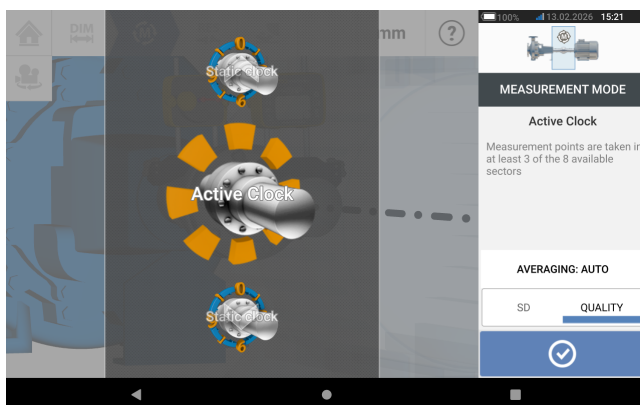

Swipe the carousel up or down and select necessary measurement mode.

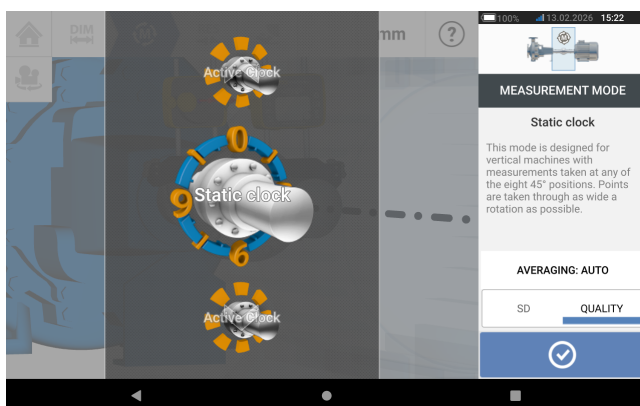

The quality of the measurement is displayed either as a measurement standard deviation (SD) or measurement quality factor.

**Standard deviation (SD)** is the root mean square deviation (mean of the means) of the measurement points. It describes how closely a group of data points are clustered around the average of those data points. It is a measure of the measurement calibre. The smaller the SD, the better the quality of the data collected.

**Measurement quality** is a factor defined by these measurement and environmental criteria: angular rotation, standard deviation of the measurement ellipse, vibration, rotation evenness, angular rotation inertia, direction of rotation, speed and filter output. The higher the factor, the better the quality of measurement.

Tap **SD** for standard deviation or **QUALITY** for measurement quality. Tap **AVERAGING** to set the averaging.

## Averaging

In certain industrial conditions, it is necessary to increase the number of measurements (recorded laser pulses) to be averaged when readings are taken, so as to get the necessary accuracy. Particular cases include environments with increased machinery vibration. An increased averaging also improves the accuracy when sleeve bearings, white metal bearings and journal bearings are measured.



Tap **AVERAGING (1)**. A scale **(2)** used to set the averaging value is shown. Tap necessary averaging value. This value is shown in the **AVERAGING** button **(1)**.

## Measurement modes

---

These measurement modes are available for horizontal machine configurations:

- Active Clock – In this mode, measurement points are taken at any of the 8 available sectors. A minimum of 3 measurement points is required to determine the alignment condition, but more measurement points over a wider rotational angle is recommended.
- Static measurement – This is the default measurement mode used to measure vertical mounted machines (four feet or flange-mounted). It is also used to measure horizontal machines with uncoupled and nonrotatable shafts.

## Static measurement

This measurement mode is used for uncoupled shafts, nonrotatable shafts and vertical foot-mounted or flange-mounted machines.

If not yet completed, enter dimensions then center laser beam.

Use the measurement mode carousel and select static measurement mode (Static Clock).



- **(1)** The **left/right** navigation icons are used to position the displayed laser and sensor at the angular position related to the components mounted on the shafts.
- **(2)** On-screen hint to position displayed laser and sensor, then take measurement point



Turn the shafts to any of the eight 45° positions (i.e. 12:00, 1:30, 3:00, 4:30, 6:00, 7:30, 9:00 or 10:30 o'clock position viewed from sensor towards laser). Position shaft as accurately

as possible using either an external inclinometer or protractor. Tap the pulsating **M** or  to take the first measurement point.



- **(1)** Number of points already taken (in this example initial point)
- **(2)** Tap pulsating **M** to take next measurement
- **(3)** On-screen hint to position displayed laser and sensor then take measurement point
- **(4) Cancel** icon – used to cancel current measurement and start new measurement

Rotate shaft to the next measurement position. The laser and sensor shown must be at the

same angular position as the mounted components. Use  or  to position the shown laser and sensor, then tap the pulsating **M** **(2)** to take next measurement point.



### Note

After a measurement point is taken, the shown laser and sensor move to the next clock position on the screen.

If shaft rotation restrictions hinder the measurements at particular shaft positions, use

◀ or ▶ to bypass those positions.

Measurements must be taken in at least three positions over 90°, but more measurements over a wider angle is recommended.

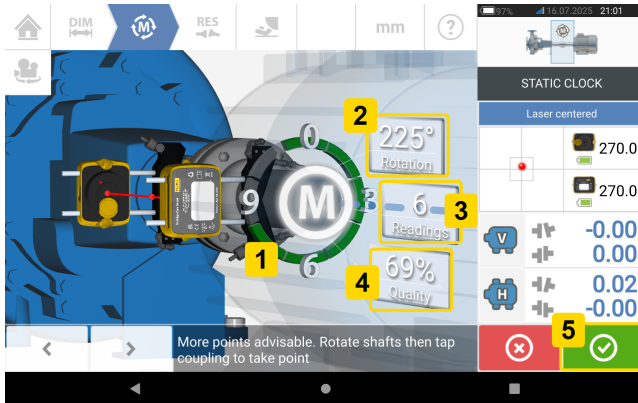

- **(1)** Rotational arc showing rotational angle covered by the shafts during measurement. The color of the arc sectors shows the attained measurement quality **(4)**
- **(2)** Rotational angle completed by the shafts for current measurement
- **(3)** Number of measurement points taken for current measurement
- **(4)** Measurement quality for current measurement
- **(5) Proceed** icon – tap to continue to view measurement results. The color of the proceed icon corresponds to the color of the rotational arc which denotes the attained measurement quality.

## Active Clock measurement

In Active Clock, measurement points are taken at a minimum of 3 to a maximum of the 8 available sectors. The range in which the sectors become active and therefore points may be taken is the given clock position (in degrees)  $\pm$  11.25 degrees. For example, the 1:30 o'clock position will be active when the sensor and laser are at a rotational angle between 34 - 56 degrees.

Clock position	0:00	1:30	3:00	4:30	6:00	7:30	9:00	10:30
Active Clock range in degrees	349 - 11	34 - 56	79 - 101	124 - 146	169 - 191	214 - 236	256 - 281	304 - 326

Active Clock is used to measure standard horizontal coupled machines. Measurement points are taken at any of the eight available sectors. Three measurement points are necessary to determine the alignment condition.

Once the laser beam has been centered, rotate shafts to the first measurement position.

 **Note**  
 If coupling torsion play (backlash) is suspected, turn the shaft or coupling end where the laser is mounted. Ensure shafts are turned in the normal rotation direction of the machine, and that the mating parts are engaged. Backlash may also be minimized by taping tight the coupling.  
 Remember not to touch mounted components. This includes the brackets and the support posts, which are NOT to be used to rotate the shafts.

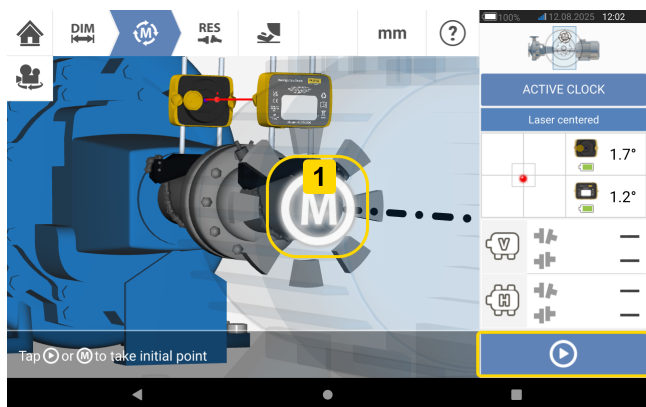

When the sensor and laser are within the sector range, a pulsating **M (1)** appears. Tap the pulsating M or  to take the first measurement position.

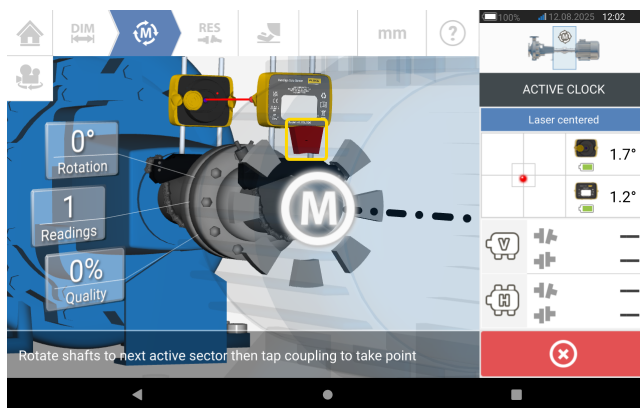

After measurement is taken, the sector is highlighted red. This is an indication of the measurement quality. Rotate shafts to the next sector, then tap the pulsating M to take measurement. Repeat this step for the set active points. The color of the measured sectors shows the attained measurement quality.

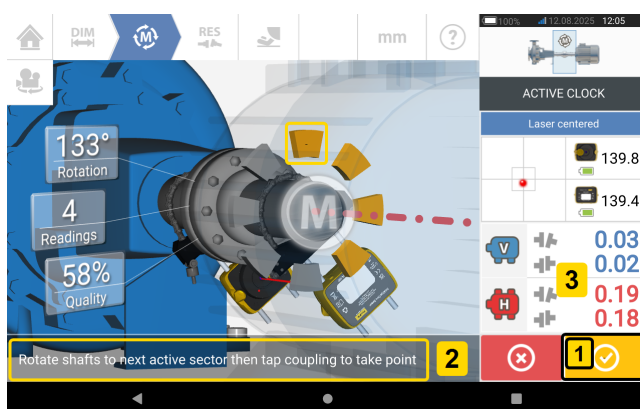

The proceed icon  (1) also indicates the attained measurement quality. As a maximum of 8 points can be taken, therefore the hint (2) to take further measurement points. Note: Coupling results (3) are displayed because three measurement points are sufficient to determine the alignment condition.



#### Note

As shafts are rotated, and depending on the physical condition of the machines, the active clock sectors change color from red (quality < 40%) to amber (quality  $\geq 40\%$  < 60%) to green (quality  $\geq 60\%$  < 80%) to blue (quality  $\geq 80\%$ ). Coupling results are displayed as soon as the measurement quality attains 40% (active clock sector turns amber).



Once sufficient measurement points have been taken, tap  to proceed to see results or measure again.

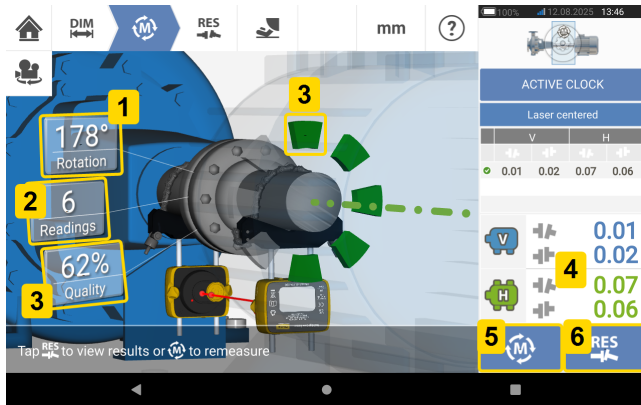

#### Note

The color of the **Proceed** button () is related to the color of the rotational arc. This shows the attained measurement quality.



- (1) Rotational angle covered by the shafts
- (2) Active clock measurement points taken
- (3) Measurement quality attained
- (4) Coupling results displayed as soon as the measurement quality reaches 40% (active clock sector is orange)
- (5) Tap  to measure machines again.
- (6) Tap  to view machine foot results.

### Take measurement points automatically

Measurement points are taken automatically if the default setting item **Take points automatically after stabilization** has been activated. The item **Default settings** is found in configuration.

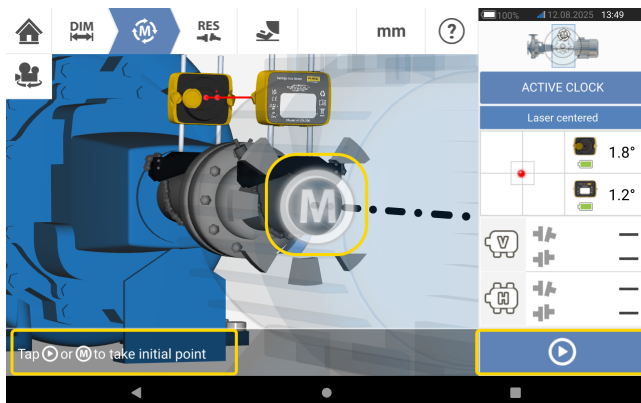

The initial measurement is taken by tapping either the pulsating **M** or  after stabilization.  
The shafts are rotated to the next sector range.

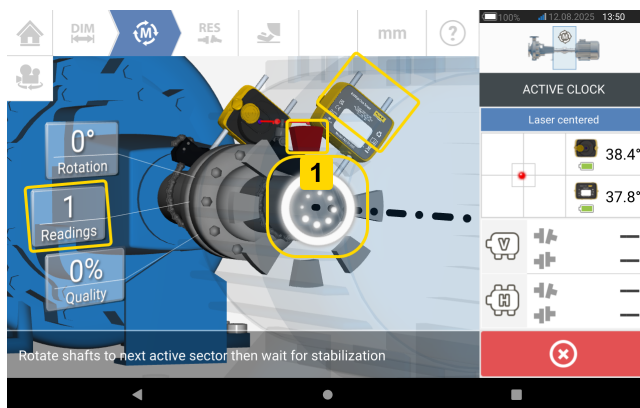

When the rotational angle of the sensor and laser is within the sector range, a series of dots in circular motion (**1**) indicate the stabilization process. Once this occurs, stop the rotation of the shafts and wait for the pulsating **M** to appear. The measurement point is taken automatically.

Repeat the procedure until all necessary active clock measurement points are taken.

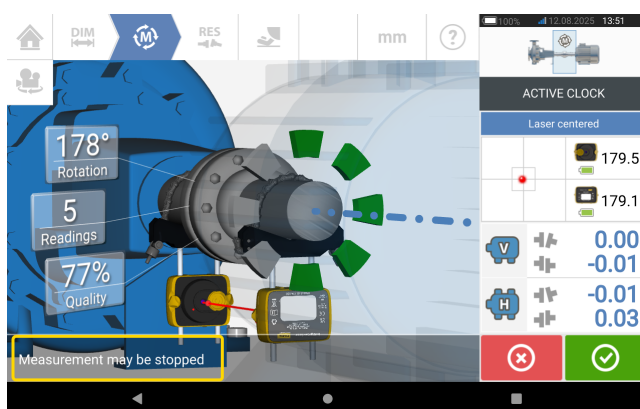

## Extend measurement range manually

Measurement range may be extended manually in both Active Clock and Static measurement modes. This range extension helps with the adjustment of the laser beam so that it does not miss the detector surface when shafts with large or angular misalignment are measured. To extend the range during measurement, go to the XY view before the **Laser End** message appears.

- If the laser dot (1) moves away from the center of the detector screen during shaft rotation, tap the detector area (2) to open the **XY view** screen.

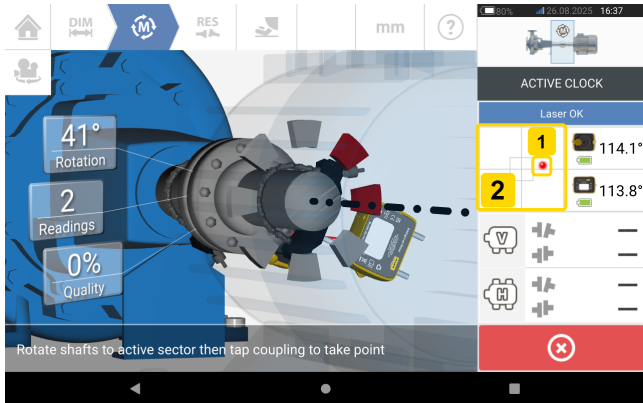

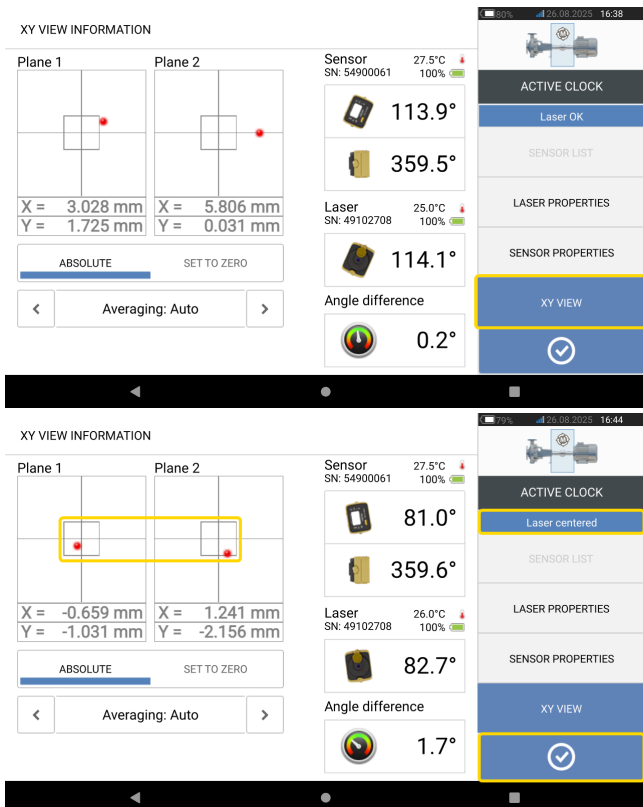

- Move the laser vertically and horizontally to adjust the laser dots on the XY screen. Continue the adjustment until the dots are inside, or very close to, the square targets.

 **Note**  
Do not touch the sensor at any time during the adjustment of the laser beam dot.

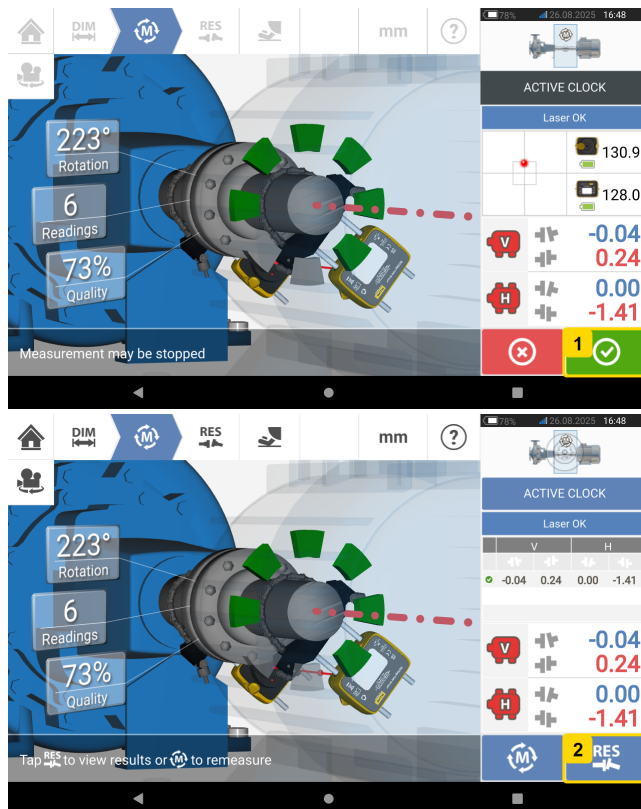

- With the laser beam centered, tap  then continue with measurement by rotating the shafts further.



- After rotating the shafts through as wide an angle as possible, tap  (1) to proceed to results, then  (2) to view results.



### Note

The color of the proceed icon () depends on the attained measurement quality.

## Measurement table

The measurement table is used to register and display all Shaft alignment, and any Live Move measurements taken on the current couplings. To access the measurement table, tap either the results repeatability table (1) or coupling results (2) / (3).



These items are included in the measurement table for each measurement:

MEASUREMENT TABLE mm

#	MEAS.	VERTICAL	HORIZONTAL	QUALITY
13	AS FOUND	-0.05 0.03	-0.06 0.06	QF SD
1	1	-0.01 -0.02	0.07 0.05	80% 0.027
2	2	-0.05 0.03	-0.06 0.06	68% 0.004
14	+ MOVE	-0.06 0.03	-0.05 0.07	-- --
15	AS LEFT	-0.03 -0.00	0.02 0.01	71% 0.013

MEASUREMENT TABLE mm

ELEMENT DETAILS				SENSOR		LASER	
STANCE	AVG [S]	ROTATION	EXTEND	S/N	RECAL	S/N	RECAL
85	Auto	↻	📷	54900061	21.08.2027	--	21.08.2027
85	Auto	↻	📷	54900061	21.08.2027	49100054	21.08.2027
85	Auto	↻	📷	54900061	21.08.2027	49100054	21.08.2027
85	Auto	↻	📷	54900061	21.08.2027	49100054	21.08.2027

- **(1)** Tap the check box to include the measurement for calculation of the averaged results shown in the results screen. Measurements with a green check mark included in the results. The check mark is grayed out if the measurement is not selected.
- **(2)** Measurements in chronological order
- **(3)** Used measurement mode
- **(4)** The rotational angle covered during measurement
- **(5)** Vertical and horizontal gap and offset values
- **(6)** Measurement quality factor (QF)
- **(7)** Measurement standard deviation (SD)
- **(8)** Date and time when measurement was taken
- **(9)** Dimension sensor-to-coupling center
- **(10)** Averaging used
- **(11)** Direction of shaft rotation during measurement
- **(12)** Serial number of sensor and laser used and recalibration due dates

The **AS FOUND** coupling result (**13**) shows the initial alignment condition of the machines before any Live Move is performed. The displayed result can be an average of selected measurements. In this example, the **AS FOUND** coupling result is the average of the selected measurements numbers 1 and 2.

The **MOVE** result (**14**) shows the alignment condition after Live Move.

The **AS LEFT** coupling result (**15**) shows the alignment condition measured after Live Move. The displayed result can be an average of selected measurements. In this example, the **AS LEFT** coupling result is based on measurement number 1 only.

Swipe horizontally to view all columns in the table and vertically to view all rows in the table.

Tap  to display the weighting of the quality factor parameters of the measurement.

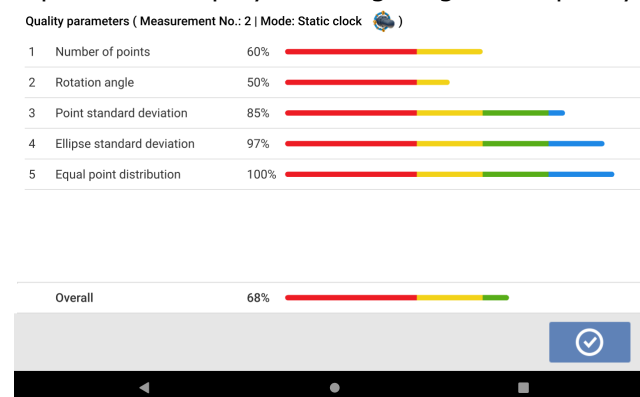

Tap  to delete the selected measurement values from the measurement table.  
**Note:** The row for the selected measurement is highlighted.

Tap  to exit the measurement table.

## Measurement quality

These color codes are used to show the measurement quality:

Blue – excellent; Green – acceptable; Yellow – not acceptable; Red – poor

Measurement quality is based on these measurement and environmental criteria:

- Number of points – The higher the number of measurement points taken, the better the effect on the quality factor. The measurement points should be spread over as wide a rotational angle as possible.
- Rotation angle – The wider the rotational angle through which the shafts and/or couplings are rotated during measurement, the better the effect on the quality factor.
- Point standard deviation – For every measurement point, a number of readings are taken depending on the set averaging. Point standard deviation is the root mean square deviation of these readings.
- Ellipse standard deviation – This is the root mean square deviation of the measurement points on the calculated ellipse.
- Equal point distribution – In point measurements, it is advisable to take measurements at equal angular steps, say  $0^\circ$ ,  $45^\circ$ ,  $90^\circ$ ,  $135^\circ$ .

## Results

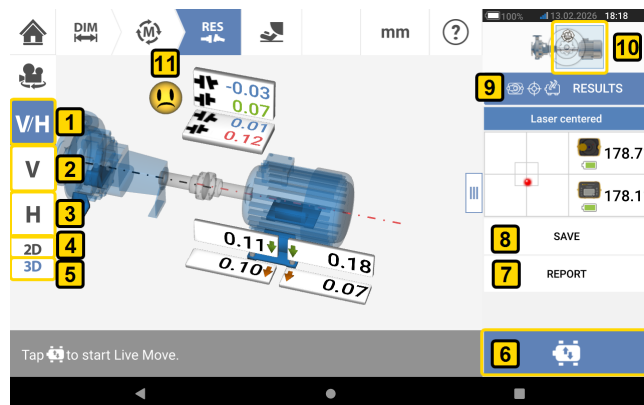

- **(1)** Displays both horizontal and vertical foot results simultaneously
- **(2)** Used to display vertical foot results only
- **(3)** Used to display horizontal foot results only
- **(4)** Used to display foot results in 2-D
- **(5)** Used to display foot results in 3-D
- **(6)** Starts Live Move
- **(7)** Used to generate asset measurement report
- **(8)** Used to save asset measurements in asset park
- **(9)** Used to select results mode
- **(10)** Tapping the slider on the machines icon opens the triple "Train Manager" / "Train Setup" / "Train Fixation" screen (Note: Only "Train Fixation" is active.)
- **(11)** Alignment condition tolerance symbol

In the results screen, the three icons    – dimensions, measurement and results – are active and may be used anytime.

The 2-D V and H foot results screens show the vertical (V) and horizontal (H) foot positions respectively.

The colors of the bold arrows next to the feet correction values are directly related to the coupling alignment condition as follows:

- Blue – excellent (foot should not be moved)
- Green – acceptable (if possible foot should remain unaltered)
- Red – poor (foot requires moving to attain a better alignment condition)

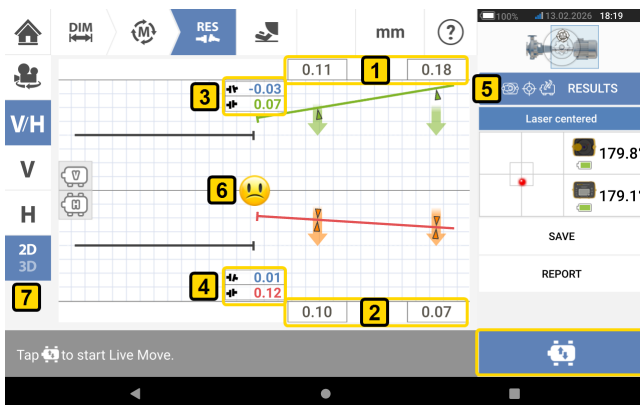
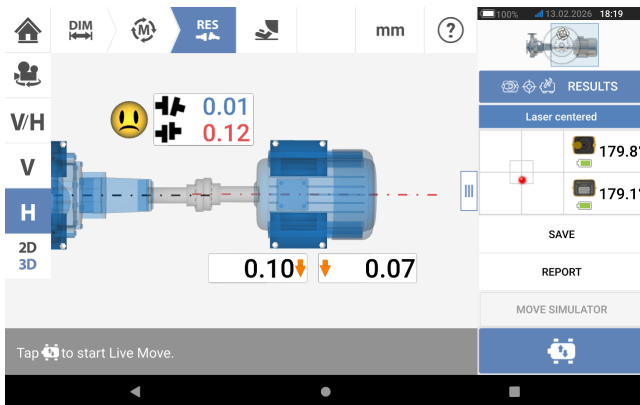
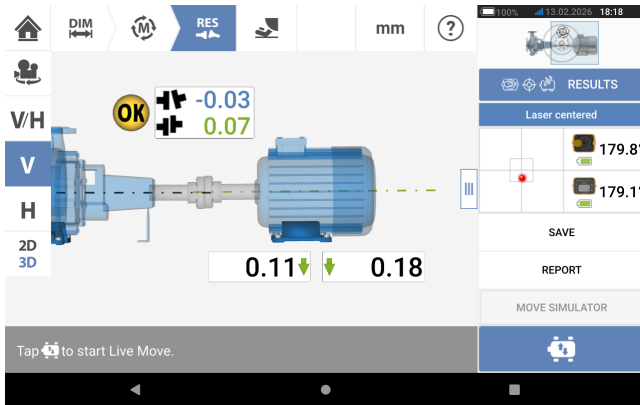

- **(1)** Vertical foot position results
- **(2)** Horizontal foot position results
- **(3)** Vertical coupling results
- **(4)** Horizontal coupling results
- **(5)** Selected results mode
- **(6)** Alignment condition tolerance symbol
- **(7)** Horizontal and Vertical foot results in 2-D

## Results options

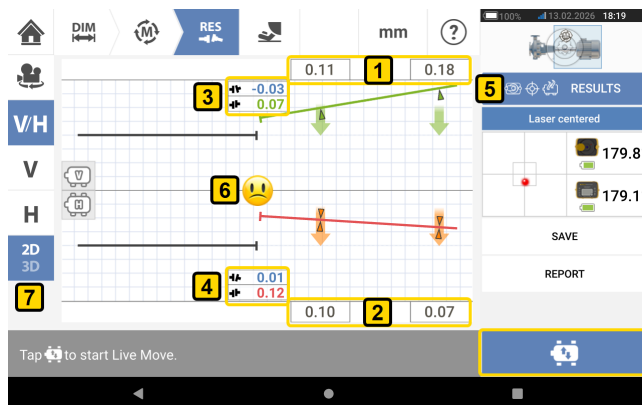

Alignment results may be displayed in three different options. To access the available options, tap **5**.



Use the results mode carousel to select the necessary results option then tap  to confirm selection.

The following options are available:

- 'Actual' – used to show just the measured alignment values without regard to any target values or thermal growth values that have been entered, even if they are active
- 'Specification' – shows just the effect of any target specifications and/or thermal growth values that may have been entered and activated, from a baseline of zero, without regard to any measured misalignment
- 'Actual minus Specification' – this option considers any specified coupling targets or machine thermal growth, and is the default view. It is the option that should be used when actually performing alignment corrections

## Sign convention

Coupling gap is positive when open at top or side away from viewer. The viewer is considered to be standing in front of the machines as they appear on the display.

Offset is positive when the right shaft axis is higher than the left shaft axis or further away from the viewer than the left axis.

Both vertical and horizontal results show the foot position relative to the centerline of machine designated stationary. Positive values indicate that machine is upwards or away from viewer. Negative values indicate that machine is downwards or towards the viewer.

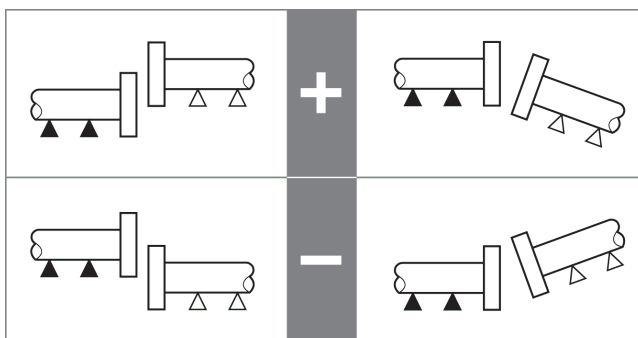

## Multiple feet results

### Foot corrections

Foot corrections in a multiple feet machine are viewed from the result screen.





If results are displayed in 3D, tap the machine (1) to access the results multiple feet screen. In 2D, tap the machine centerline (1) to access the multiple feet screen.

 **Note**  
 If the machine intermediate feet were already defined within machine properties, then the foot corrections for the intermediate feet will be displayed. In this example, the intermediate feet have not been defined.

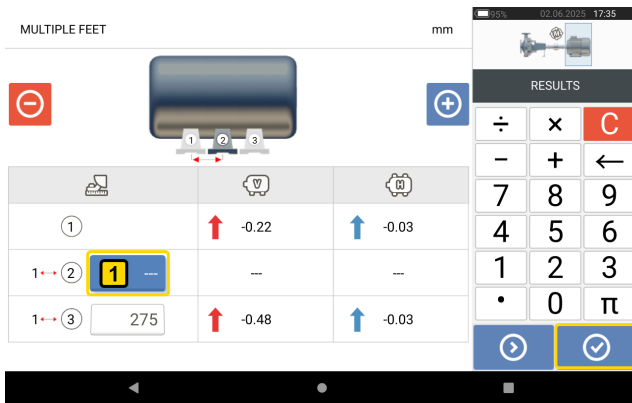

Tap  to add any intermediate feet.



Enter the dimension between the front feet and the intermediate feet in the row that appears (1) then tap .

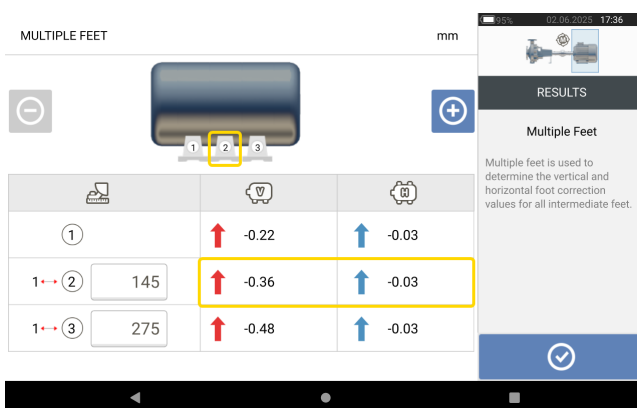

The foot correction values for the intermediate feet appear in the corresponding row.

## Saving asset measurements

### Saving an asset

Before the device is switched off, dimensions, measurements, results and all settings can be saved for analysis, future use or record purposes in the device memory or transferred via Cloud or USB to ARC 4.0 the PC software. Asset measurements are saved from the results screen.

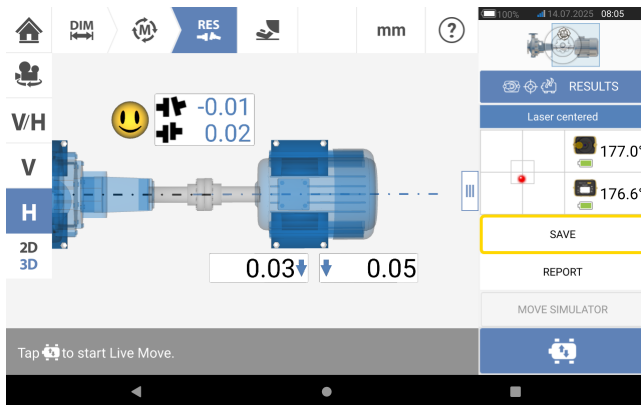

To save an asset measurement, tap the menu item **SAVE** then use the onscreen keyboard to enter the measurement file name.

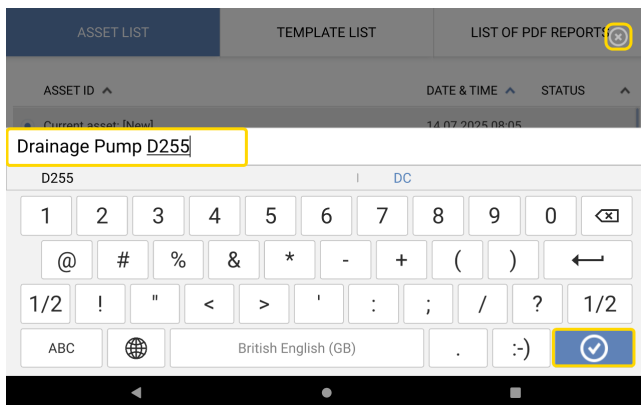

Once asset name has been entered, tap  to save the asset under **Asset park**. This is the location where asset measurements are saved.



#### Note

If for any given reason, the asset is not to be saved, tap the cancel icon () to cancel saving.

Asset refers to machinery and equipment within a plant. The asset is listed as an Asset ID. Access Asset park via the home screen.

ASSET ID ^	DATE & TIME ^	STATUS ^
• Drainage Pump D255	14.07.2025 08:06	
○ Drainagd	14.07.2025 08:03	
○ Grundfoss2B	11.07.2025 17:43	
○ Drainage Pump 223D	11.07.2025 15:14	
○ Xx22	07.07.2025 15:11	

The status envelopes indicate whether an asset has been measured or not.

- This icon shows that the asset has been imported from ARC 4.0 but is yet to be opened.
- This icon shows that the asset has been opened but the alignment measurement has not been completed.
- This icon shows that the alignment measurement is in progress.
- This icon shows that the alignment measurement has been completed.

## Asset list options

ASSET ID ^	DATE & TIME ^	STATUS ^
• Drainage Pump B255	14.07.2025 08:10	
○ ACME_RPM_1490	14.07.2025 08:03	
○ Grundfoss2B	11.07.2025 17:43	
○ Drainage Pump 223D	11.07.2025 15:14	
○ Xx22	07.07.2025 15:11	

Tap the related icon to do these actions on the selected asset:

- **(1)** Uploads the selected asset to the cloud. Note: The action is completed only if wireless connection is enabled.

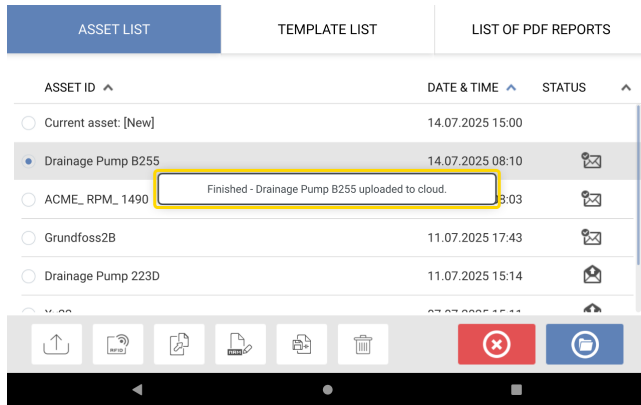

- **(2)** Assigns selected asset to an RFID tag.

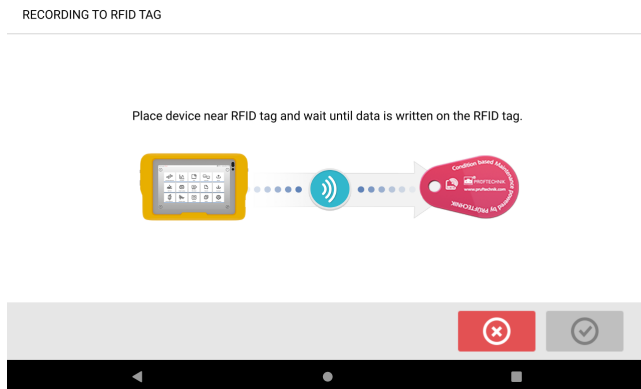

- **(3)** Opens the selected asset as new asset. The new asset will be a copy of the selected asset without the sensor-to-coupling center dimension, and any asset measurements.

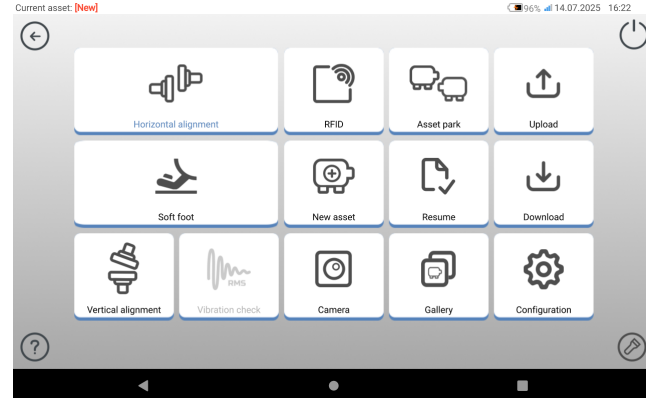

Tap the applicable icon to start necessary application. The new asset opens and is edited as required.

Assets opened this way, are used as templates. This asset is then saved with a new asset name.

- **(4)** Used to edit directly the name of the selected asset.

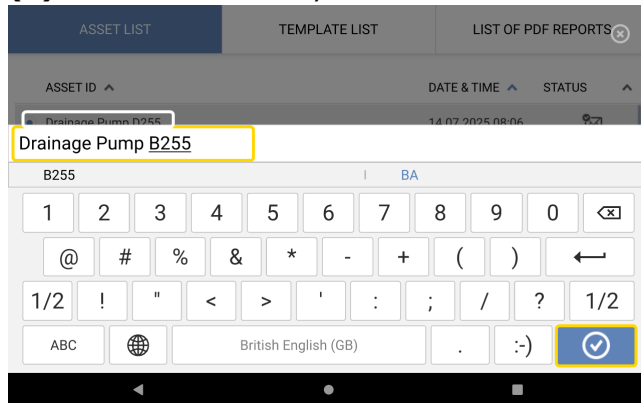



Once completed, tap . The asset will now appear in the asset list with the new name.

- **(5)** Used to create a template.

A template is a file that serves as a pattern for alignment set-ups that are repeated frequently. Their main purpose is to save time by not having to reconfigure the same set-up many times. It can contain all known dimensions (except sensor-to-coupling center), target specifications, thermal growth values, tolerances, preferred measure mode, preferred machine icons and coupling types.

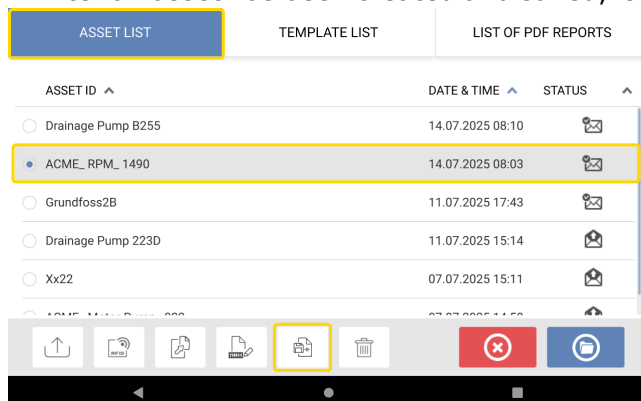
> After an asset has been created and saved, it appears on the asset list.



> Tap  to save the asset as a template.

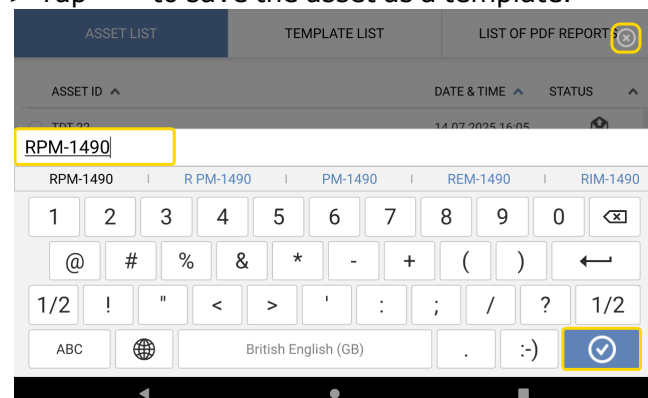

> Enter name of template then tap .

- 

**Note**

If for any given reason, the template is not to be saved, tap the cancel icon  to cancel saving.

> The created template now appears on the template list.

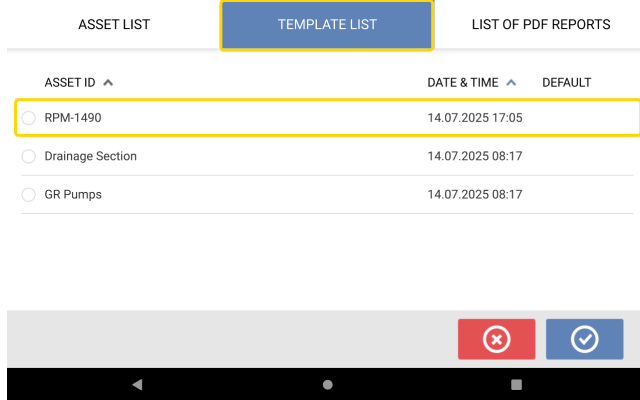

- **(6)** Used to delete selected asset.
- **(7)** Used to exit the asset list/template list screen and return to the home screen.
- **(8)** This symbol () signifies that the selected asset is open and running in the background. The symbol serves the dual purpose of either opening the selected asset or saving any changes that may have been applied to the asset but not yet saved.

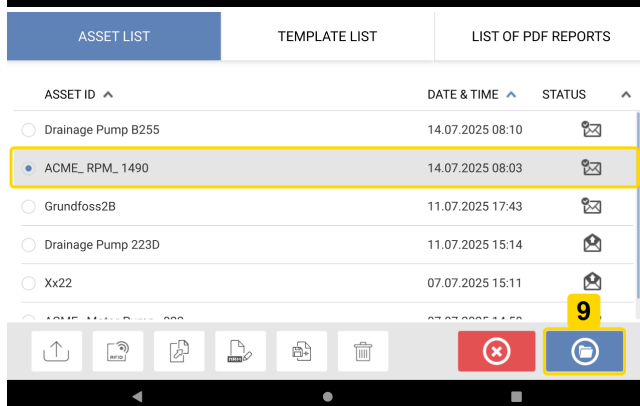
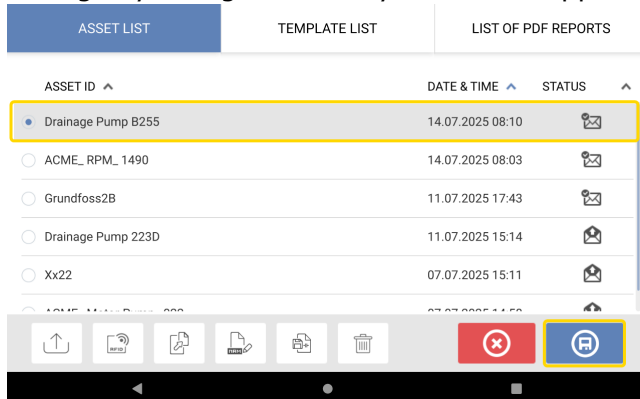

If an asset that was previously saved but currently not open is selected, then the symbol

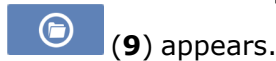

**Note**

If the selected asset has not been previously saved, it can be saved as a template (1). The other asset list options are inactive.

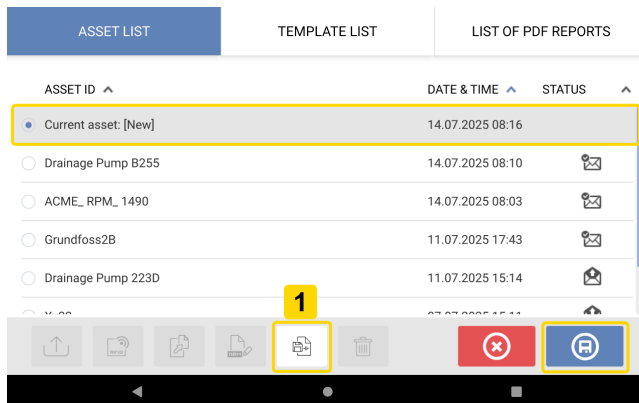
**Default template**

It may be necessary to define any one template as the default template. The default template will be used whenever a new asset is opened within the home screen.

> All available templates are listed on the template list.

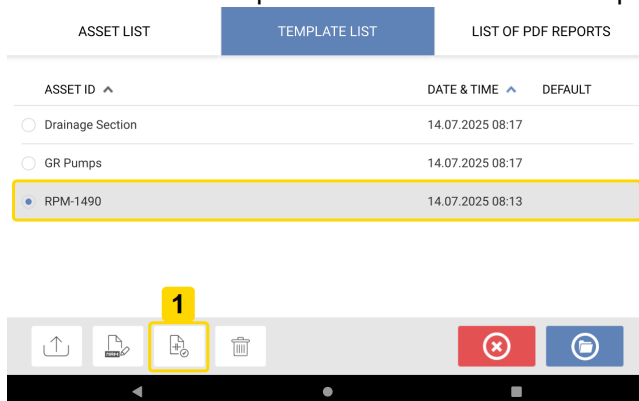

> Select template to be designated as default, then tap  (1).

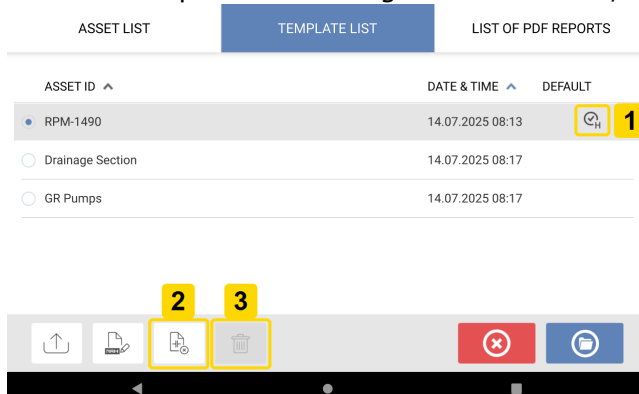

> The default template now appears on the template list with a check mark (1).

> To revert the default template to a normal template, tap  (2).

> **Note:** The designated default template cannot be deleted (3). To delete it, it must first be reverted to a normal template.

Note: If no template is selected, all template list options are unavailable.

ASSET LIST	TEMPLATE LIST	LIST OF PDF REPORTS
ASSET ID ^	DATE & TIME ^	DEFAULT
<input type="radio"/> RPM-1490	14.07.2025 08:13	
<input type="radio"/> Drainage Section	14.07.2025 08:17	
<input type="radio"/> GR Pumps	14.07.2025 08:17	



## Generate reports

### Generate measurement reports

Asset measurement reports can be saved directly on the rugged device as PDF, sent via email, or exported as .csv, .json, or .xml files. Measurement reports are generated from the results screen.

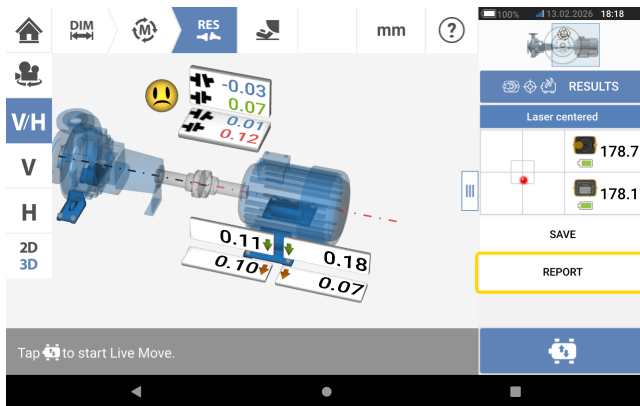

Tap the menu item **REPORT**. The **GENERATE REPORT - REPORT TEMPLATES** screen opens.

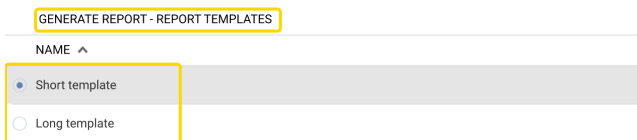

The report can be created with a short or long template, and in either graphical or text format.

Select necessary options, then tap  to proceed.

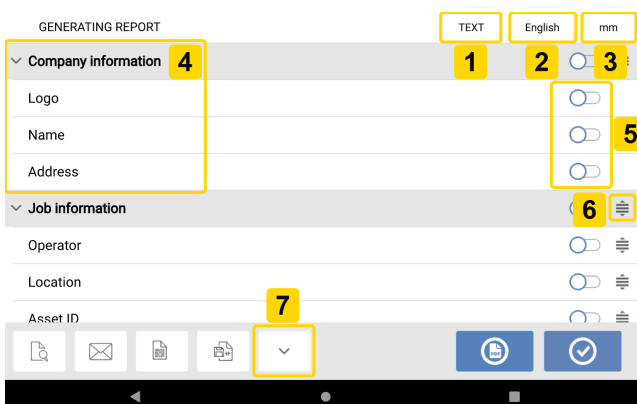

- |   |   |
|---|---|
| 1 | Tap to switch between text and graphical report formats |
| 2 | Tap to select the language for the report               |

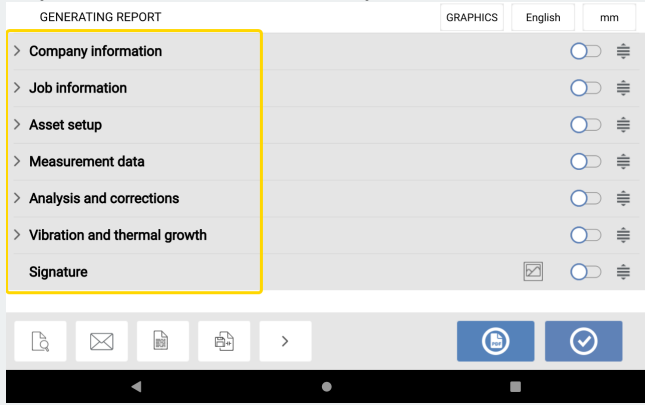
<b>3</b>	Tap to switch between mm and inches
<b>4</b>	Tap to expand or collapse the section to see the related sub-items
<b>5</b>	Tap the related icon to turn on or off items that will appear in the report <b>Note:</b> In this example, all items are off
<b>6</b>	Hold the icon and drag up or down to reposition the section
<b>7</b>	Tap to show all available report sections 

## Sections of the report

- **Company information:** Logo, Name, Address
- **Job information:** Operator, Location, Asset (Machine) ID\*, Comment, Date\*\*  
\*Asset ID appears only after the asset has been saved  
\*\*Date is set automatically
- **Asset setup:** Description, Graphical overview, Dimensions, Tolerances, Components, Images
- **Measurement data:** Shows all key measurement results, plus historical values and tables
- **Vibration and thermal growth:** Vibration measurement, Thermal growth
- **Analysis and correction:** Graphical results, Train corrections, Measurement quality plus ellipse, Soft foot, Targets, ROI, Periodicity

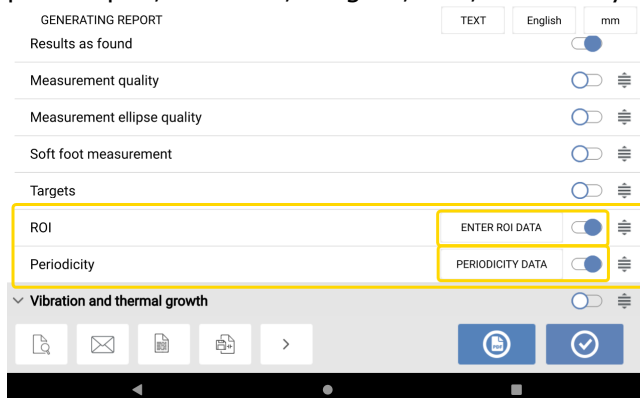



If either ROI (Return on Investment) and/or Periodicity are on, related data must be entered and edited. To do so, tap **ENTER ROI DATA** or **PERIODICITY DATA** as necessary.

**Note:** Periodicity is a measure of how often specific actions must be done to ensure optimal performance, reliability, safety, and longevity of a machine.

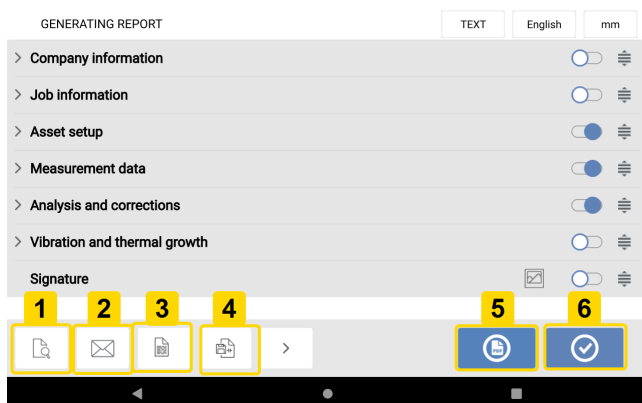
## Other generating report screen elements

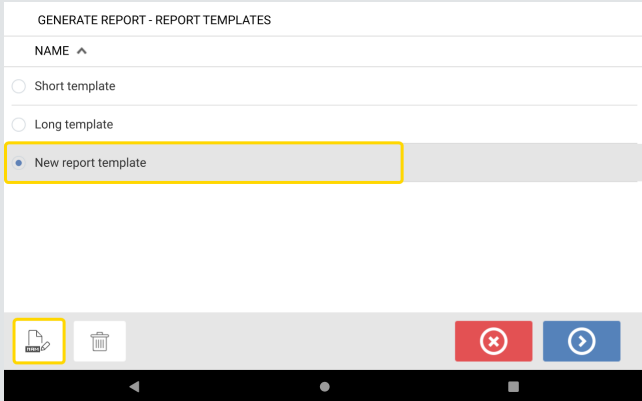

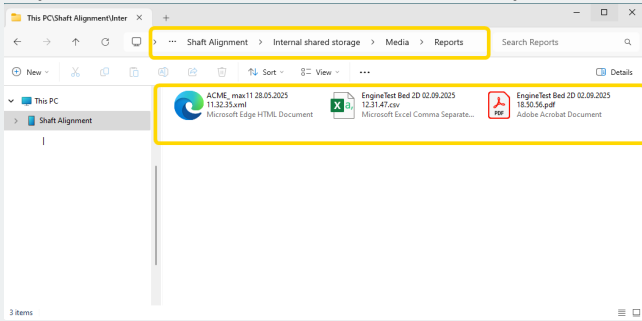
1	Tap to preview report
2	Tap to send report as PDF via email
3	Tap to export report as a .csv, .json, .xml file, or send it to ARC 4.0
4	<p>Tap to save report as a new report template.</p>  <p>The new template has a generic name. Tap  to edit it.</p>
5	<p>Tap to save the asset measurement report as PDF on the rugged device</p>  <p>The report is in the folder <b>Reports</b> found in this path: <b>Shaft Alignment\Internal storage\Media\Reports</b>  <b>Note:</b> The generated PDF report saved together with the asset can also be opened via the software platform ARC 4.0 in <b>Asset Attachments</b>.</p>
6	Tap to save entered information and exit the report generation screen

## Report logo

The necessary report logo must initially be saved within the rugged device before it can be added to the measurement report. These image formats are supported: png, bmp, jpg and jpeg

- Connect the rugged device to a PC.

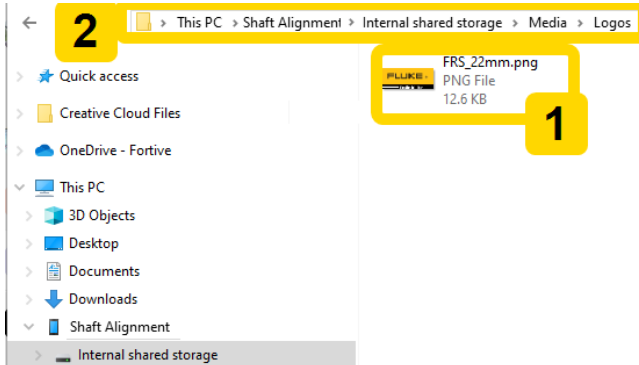

Save the necessary logo (1) in the folder **Logos** found in this path: **Shaft Alignment\Internal storage\Media\Logos (2)**

- Disconnect the rugged device from the PC.

The added logo will be shown in the report logo gallery.

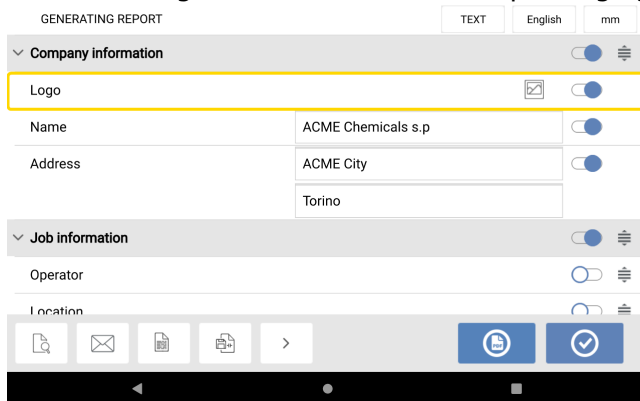

To add the logo to the report, the item **Logo** must be on.

- Tap . The report logo gallery opens.

REPORT LOGO GALLERY



- Tap the necessary logo and then tap . The selected logo will now appear on the PDF measurement report when **Logo** is on.  
**Note:** The delete icon is active. In this case, the added logo can be deleted from the gallery.

## Add signature to report

A signature on the report ensures authenticity and verifies that the job was reviewed by the responsible party.

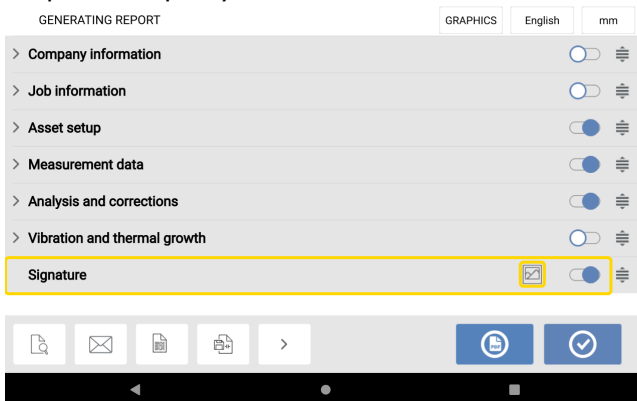

In the generating report screen, turn **Signature** on, then tap .



Use a finger or an applicable stylus and sign on the device display, then tap  to exit.

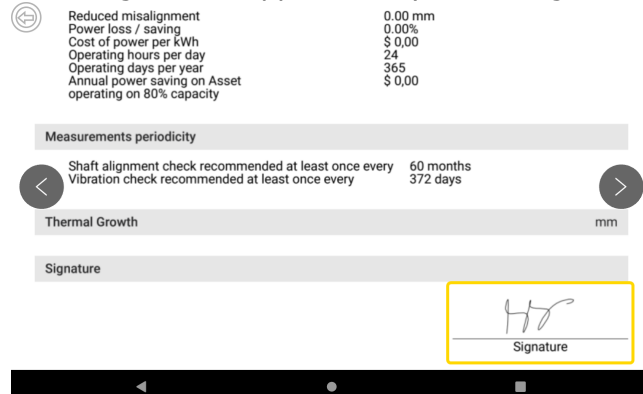

The signature is shown at the bottom of the report if the item **Signature** is on.

## Live Move screen



**Note**

Aligning of machines involves vertical movement through shimming of the machine feet, and horizontal movement by shifting machine sideways.

If the alignment condition of the machines is within tolerance (indicated by 😊 or OK) then there is no need to align the machines.

It is recommended to perform vertical corrections first, since the horizontal condition is easily affected by the process of loosening anchor bolts and inserting and/or removing shims, whereas the vertical condition is less prone to being affected when performing horizontal moves.

It may be necessary to recheck soft foot before proceeding.

Live Move is monitored in both horizontal (H) and vertical (V) planes simultaneously.

### Live Move



**Note**

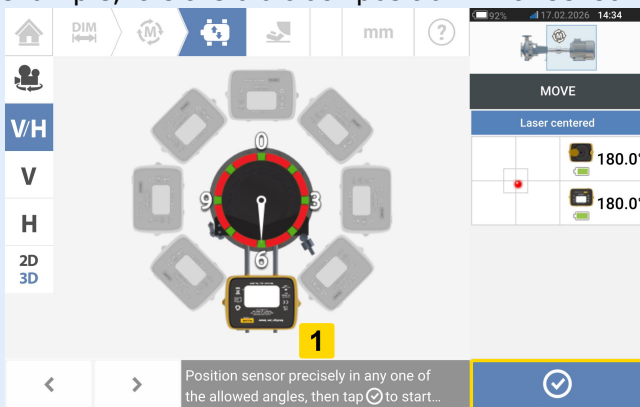

If Static measurement mode is selected, the Live Move screen is accessed only after the necessary 45° clock position (1) of the sensor and laser has been selected (in this example, it is the 6 o'clock position). With sensor position selected, tap .



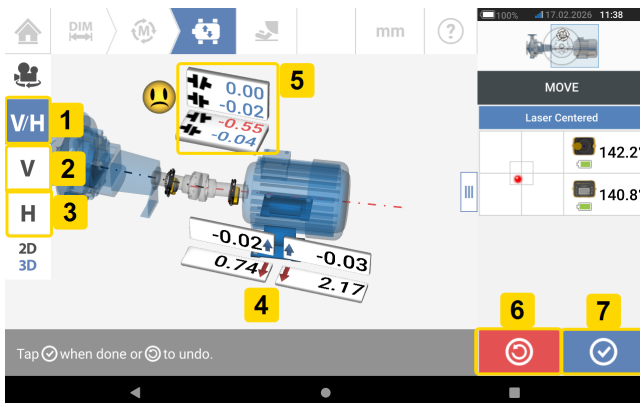

Live Move is monitored in both horizontal (H) and vertical (V) planes simultaneously.

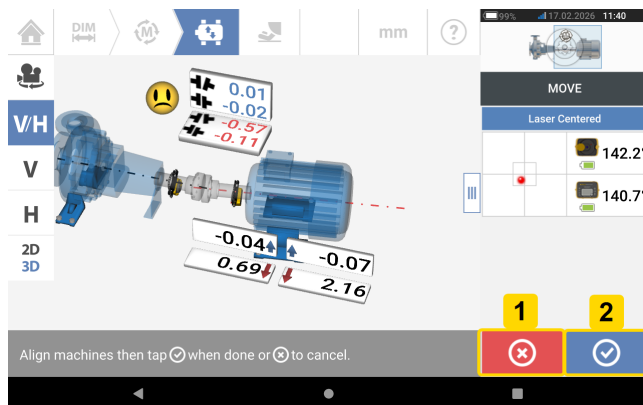

- **(1)** Tap the **V/H** icon to follow both vertical and horizontal foot corrections simultaneously
- **(2)** Tap the **V** icon to follow the vertical foot corrections
- **(3)** Tap the **H** icon to follow the horizontal foot corrections
- **(4)** Arrows indicate direction and magnitude to move machine feet
- **(5)** Tolerance coded gap and offset coupling values
- **(6)** Tap the **Undo** icon to measure again, or start Live Move again
- **(7)** Tap the **Proceed** icon to measure again, or start Live Move again

When Live Move is detected, this icon  replaces this one .



- **(1)** Tap  to show the **Cancel Move** hint.
- **(2)** Tap  to start Live Move again or measure the machines again.

If the laser beam is centered, tap  to start Live Move automatically.

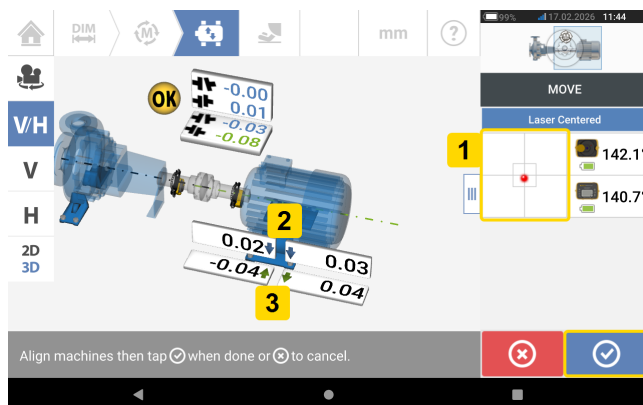

If the laser beam is not centered, tap the detector area on the screen **(1)** to access the XY View.



### CAUTION

Do NOT attempt to move the machine using heavy sledgehammer blows. This can cause bearing damage, and also produce inaccurate Live Move results. Jack bolts on the feet or other mechanical or hydraulic devices are recommended for moving machines.

Correct the alignment condition by shimming and moving the machines laterally following the bold vertical (2) and horizontal (3) arrows. The color coded bold arrows signify the attained coupling tolerance as follows: Blue (excellent condition); Green (good condition) and Red (poor condition). Machines should be moved to within acceptable tolerances indicated by a happy smiley (😊) (excellent tolerance) or an OK icon (🟢) (acceptable tolerance) while observing shaft alignment best practices.

 **Note**  
 The system monitors both horizontal and vertical Live Move simultaneously. If the vertical view (V) is selected when Live Move starts, only the vertical condition is shown, even though both planes are being monitored. Likewise, if the horizontal view (H) is selected, only the horizontal condition is displayed, while both planes continue to be monitored in parallel.

After machines have been moved to within tolerance, tighten the foot bolts then tap  .

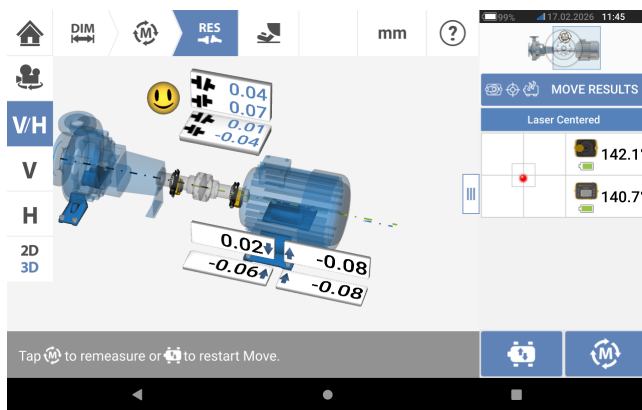

Tap  to measure again, verify the Live Move results, and confirm the new alignment condition.

## What is soft foot

---

Soft foot is the condition of machine frame distortion. Any cause that results in machine frame distortion when the machine is anchored to its foundation is a soft foot. Some of the principal causes are:

- Non-coplanar machine mounting surfaces
- Deformed machine frame or feet
- External forces e.g. from connecting pipe or bracketry
- Improper shimming or soiled machine feet
- Too many shims under a machine foot (a maximum of 5 shims should not be exceeded)

The consequences of forcibly tightening down the feet are deformed machine frames, bent shafts and distorted bearings. This leads to high vibration and premature machinery failure.

Soft foot should be checked before aligning the shafts. This can be done quickly and conveniently with the aid of the soft foot function. With the sensor and laser mounted on the shaft in the usual way, the system is able to sense any machine movement when the machine bolts are loosened individually. By entering the machine dimensions, the rugged device is able to calculate, from shaft movement, by how much each foot has moved as it is loosened. Once foot movements have been established, the results are interpreted and translated into shim thicknesses to be placed under the feet. How straightforward this is, depends on the type of soft foot present.

### Parallel soft foot

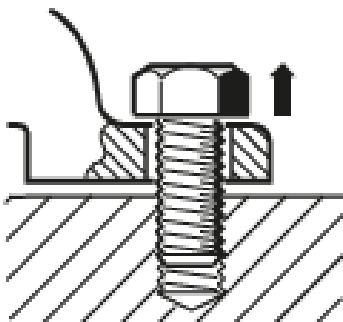

In parallel soft foot, one or more feet are too short or too long. This usually results in the machine rocking on the longer feet. This is corrected by shimming the shorter feet.

### Angular soft foot

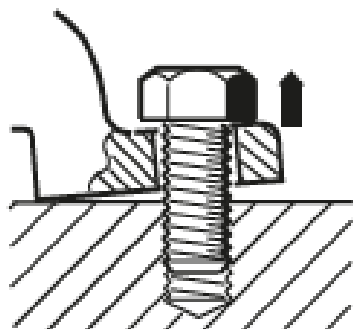

With angular soft foot, the base of the foot is at an angle to its foundation and they are only partly in contact. In this case, suspect foot is checked with a feeler gauge and corrected by building a custom 'shim wedge' or machining the underside of the foot.

### **Checking and correcting soft foot conditions**

The three main types are parallel soft foot, angular soft foot, and induced soft foot. There are instances where the soft foot is a combination of two or more types.



Checking for soft foot is part of machine and job preparation.



#### **Note**

The machine(s) to be checked is/are assumed to have four feet in an approximately square formation. If the machine has six feet, it is advisable to leave the middle feet loose and treat the machine as a four-footed machine. Soft foot is measured only on machine designated as movable.

## Soft foot

Soft foot measurement can be started from any screen where the **Soft foot** icon (  ) is active. Tap  to start soft foot measurement. The values may be determined by sensor measurement or entered manually from values established using manual methods such as feeler gauges and shims. All four foot bolts must be bolted down before starting measurement.

### Sensor measurement

Mount the components, enter all required dimensions, and then adjust the laser beam as required. (You may refer to Mounting components , Dimensions, and Laser beam adjustment.)

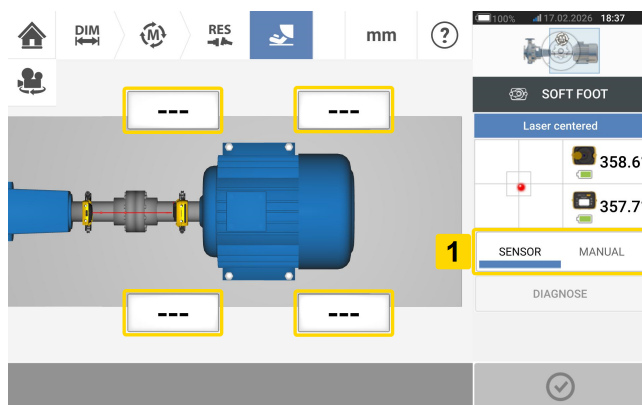

Activate sensor measurement by swiping the blue bar (**1**) **SENSOR**. The laser beam must have the status **Laser centered** or **Laser OK**.

Tap any one of the four pulsating value fields to start soft foot measurement at the related machine foot.

The adjustment screen is shown immediately after any one of the pulsating fields is tapped.



Loosen the corresponding foot bolt (see hint **1**). The recorded soft foot value is displayed (**2**).

When the soft foot value stabilizes, tap  or the value recorded (**2**), then tighten the bolt

(hint is shown in **1**). If necessary, tap  to cancel the soft foot measurement at the related foot. The above soft foot measurement procedure is repeated for all four feet positions.

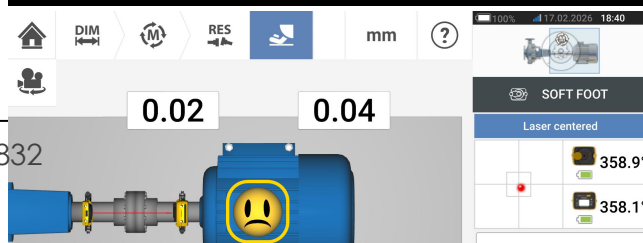
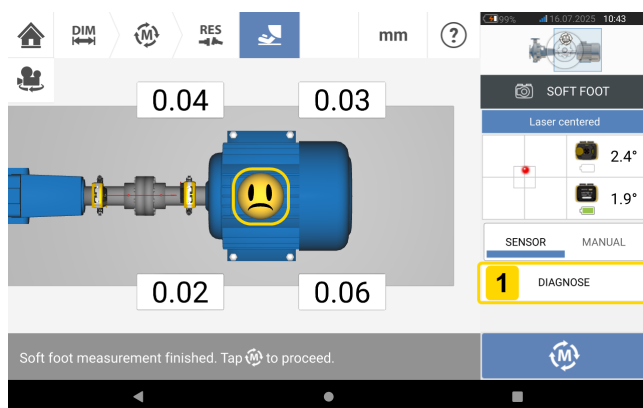

The smiley indicates the soft foot condition. A happy smiley indicates that the measured soft foot is within tolerance and further corrections are unnecessary. Acceptable soft foot tolerance is 0.05 mm (2 mil). A sad smiley indicates that the measured soft foot is out of tolerance and shimming corrections are necessary.



**Note**  
Tap the smiley on the machine image to show the set soft foot tolerance.

## Manual entry

Use feeler gauges to calculate manual values. To do this, measure four points around the bolt point with feeler gauges. The calculated values are then entered in the soft foot application. Manual values do not require use of either sensor or laser.

Swipe the blue bar to **MANUAL**. Manual entries are signified by the finger icon on the display.

Tap any one of the four pulsating value fields then use the onscreen keyboard, and enter the soft foot value at the related machine foot.

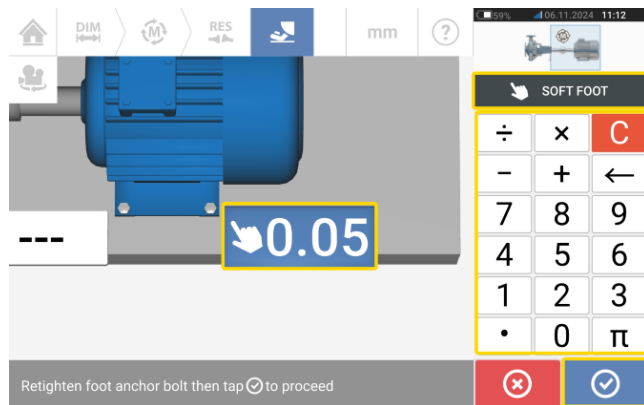

Tap  to confirm value. Repeat the procedure for all four feet positions.

The tolerance smiley gives an indication as to whether the soft foot requires correction or not.

## Vertical flanged machines

---

A typical vertical machine arrangement comprises one machine mounted on top of the other using a bolted flange.

Flange-mounted machines may have a vertical or horizontal orientation. In either case, alignment corrections are made directly at the flange.

Angularity is corrected by inserting or removing shims between the flanges. The rugged device calculates the shimming thickness for each flange bolt.

Offset is corrected by positioning the flange laterally.

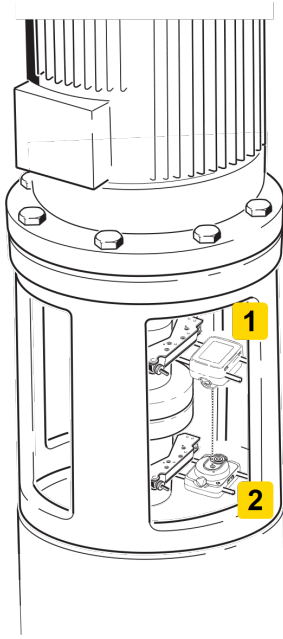

- **(1)** Sensor
- **(2)** Laser

The sensor and laser are mounted on either side of the coupling as for horizontal machines. The laser is mounted on the shaft of the bottom machine, and the sensor on the shaft of the upper machine. As the electronic inclinometer cannot directly determine the rotation angle of vertical shafts, the measurement mode for vertical machines is Static Clock.

### Marking measurement positions

For Static Clock measurement mode, the eight 45° measurement positions used with these procedures must be marked accordingly on the machine.

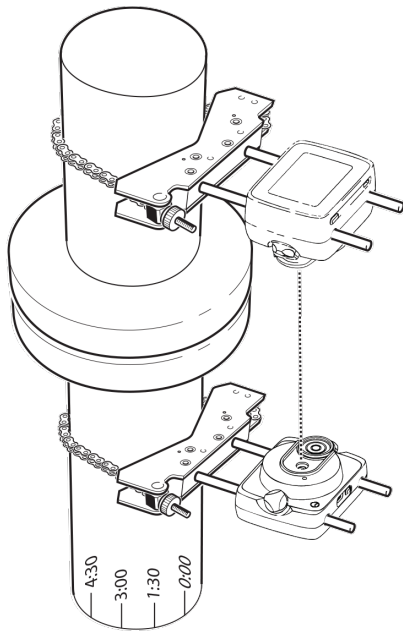

- Mark a reference position on the machine close to the shaft and in line with a convenient external reference or flange bolt. Likewise, mark a reference point on the shaft.
- Measure the circumference of the shaft and divide by eight.
- Use this distance to make seven more evenly spaced marks on the shaft beginning at your chosen starting point. Number the points counterclockwise as seen from sensor to laser, beginning with 0 first, followed by 1:30, 3:00, 4:30, 6:00, 7:30, 9:00 and 10:30.

For circular housings, measure the circumference of the machine coupling housing and divide by eight. Use this distance to make eight evenly-spaced marks on the housing beginning at your chosen start point. Number the points clockwise looking down onto the shaft with 0 as the first, followed by 1:30, 3:00, 4:30, 6:00, 7:30, 9:00 and 10:30.

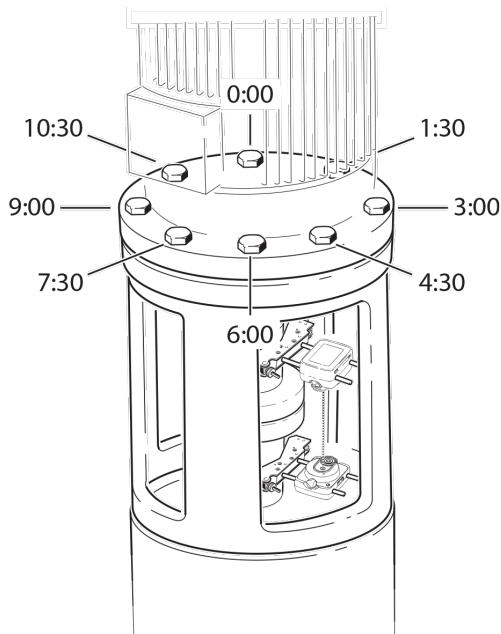

## Setup

- Mount the sensor and the laser on either side of the coupling, ensuring that they are aligned with the 0 or reference mark.
- Switch the touch device on, then tap  in the home screen to start the vertical alignment application.

Note: If the icon is inactive, tap  to activate the vertical alignment icon.

- Configure the machines as applicable. Tap the machines and select the necessary machine type from the carousel.
- Enter these required machine dimensions:

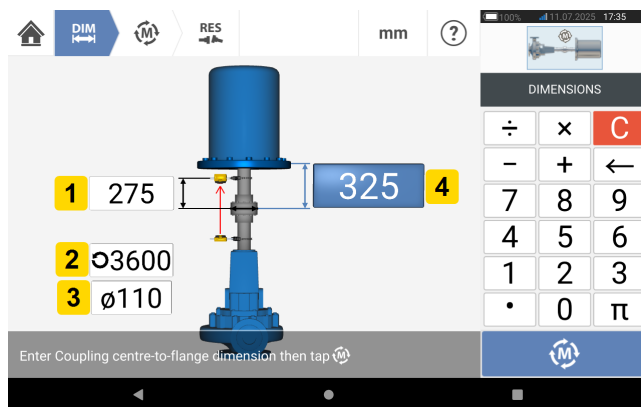

- **(1)** Sensor to coupling center
  - **(2)** RPM
  - **(3)** Coupling diameter
  - **(4)** Coupling center to flange
- When entering machine dimensions, the flange geometry must be taken into account. Tap the flange-mounted machine.

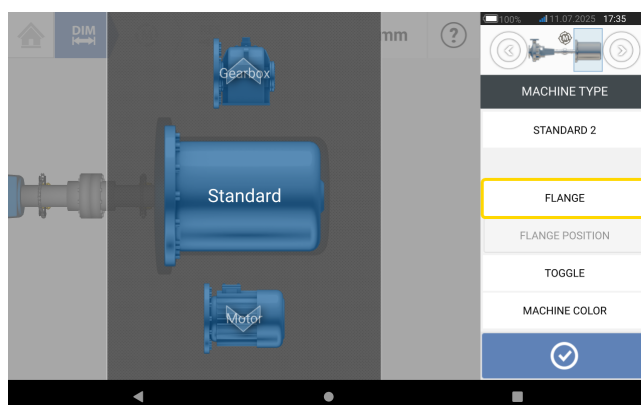

The menu items on the screen may be used to edit machine name, access the **Flange details** screen, change the flange position with respect to the shaft, flip the machine along the shaft axis (toggle) and edit machine color.

- Tap **FLANGE** to access the **Flange details** screen where the flange may be edited.

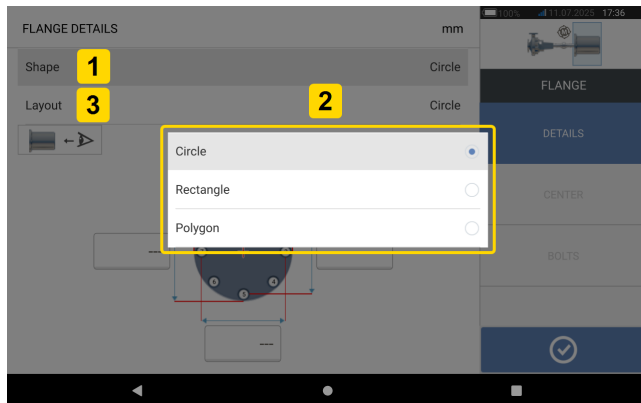

- Tap the **Shape** area (1) to select the shape of the flange from the pop-up menu (2) that appears. In the above example, the selected shape of the flange is Circle.
- Tap the **Layout** area (3) to select the pattern formed by the bolts from the pop-up menu that appears.
- Tap the respective value boxes then use the onscreen keyboard to enter flange dimensions and bolt pattern lengths.

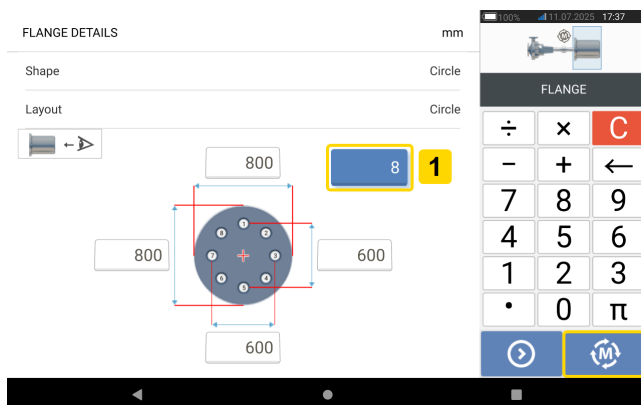

Tap the value box (1), then enter the number of bolts directly.

- After all the required dimensions have been entered, tap  to proceed with measuring.

See related topics for measurement procedures for vertical flanged machines.

## Vertical flanged machines – Static clock

### Measure with Static measurement mode

- Center the laser beam.



#### Note

Static measurement mode is used for vertically mounted machines.

- Rotate the shafts to the first measurement position. If using the coupling housing numbering convention, the reference mark and the measurement position 0 should be aligned or matched to each other.

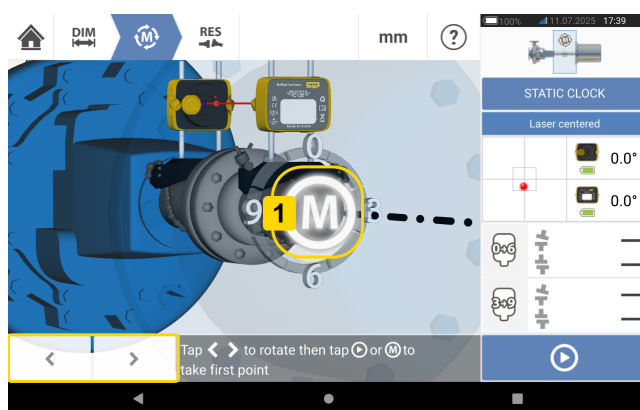

- Use **<** or **>** to position the shown laser and sensor at the angular rotation corresponding to the actual position of the components mounted on the shafts, then tap **M** (1) or  to take the first measurement point.
- Rotate shaft to the second measurement position (e.g. 1:30). If the chosen measurement position does not correspond to the angle selected automatically on the display, use the navigation keys to manually position the laser and sensor at necessary angle on the display.

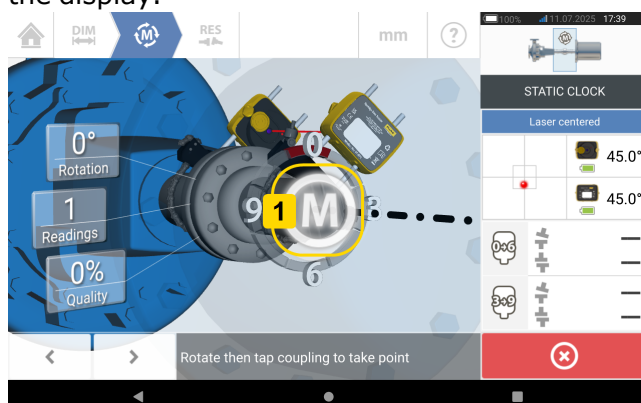



Tap **M** (1) to take the measurement point.

- Take the maximum number of measurement points to maximize the quality of results.





- Tap  to proceed to view measurement results.

 **Note**

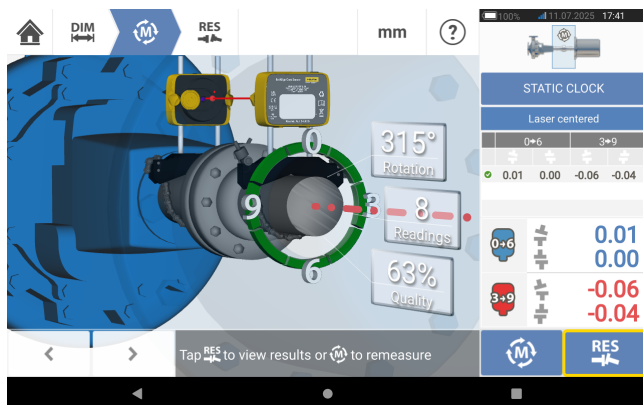
The color of the **Proceed** icon () denotes the attained measurement quality.



 **Note**

If flange dimensions have not been defined, the flange icon  appears. Tap  to enter missing flange dimensions.

- Tap  to view measurement results.

## Vertical results

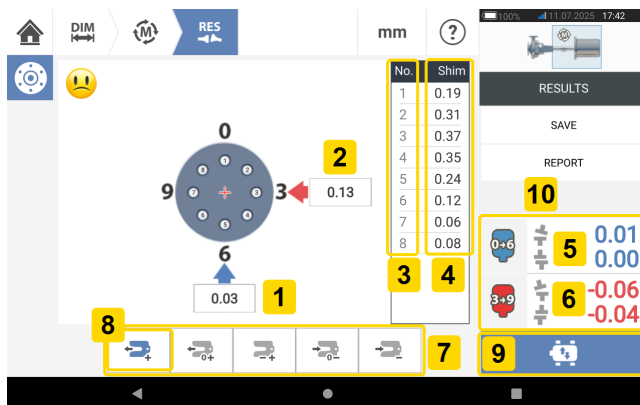

- **(1)** Flange correction in 0-6 direction
- **(2)** Flange correction in 3-9 direction
- **(3)** Bolt position
- **(4)** Shimming values
- **(5)** Coupling gap and offset in the 0-6 direction
- **(6)** Coupling gap and offset in the 3-9 direction
- **(7)** Shim correction modes
- **(8)** Shim correction mode used in this example
- **(9)** Initiates Live Move
- **(10)** Tapping the coupling results area accesses the measurement table.

In the results screen, the three icons – dimensions, measurement and results – are active and may be used anytime.

## Shimming modes



Shimming modes are defined as follows:

- **(1)** mode indicates **all positive** shimming
- **(2)** mode indicates **zero/plus** shimming. In this mode, one bolt position is set to zero and the rest are positive
- **(3)** mode indicates **optimized** shimming. In this mode, half of the corrections will positive, and the other half negative.
- **(4)** mode indicates **zero/minus** shimming. In this mode, one bolt position is set to zero and the rest are negative.
- **(5)** mode indicates **all negative** shimming

## Sign convention

POSITIVE GAP opens towards 0:00 or 3:00

POSITIVE OFFSET if the top coupling half is offset towards 0:00 or 3:00

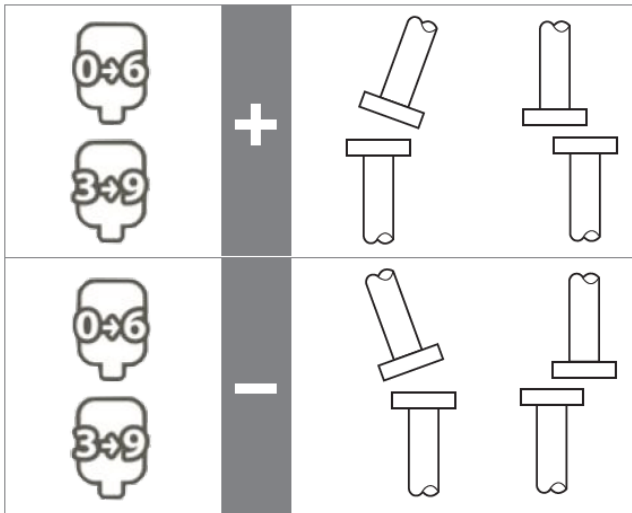

Viewpoint is always determined by looking from the sensor towards the laser.  
Note: The little clock face on the laser serves as a reminder of the viewpoint.



**WARNING**

When the sensor is switched on, the laser beam is emitted. DO NOT stare into the laser beam!

## Live Move – Vertical machines

To align vertical mounted machines, correct angularity and offset.

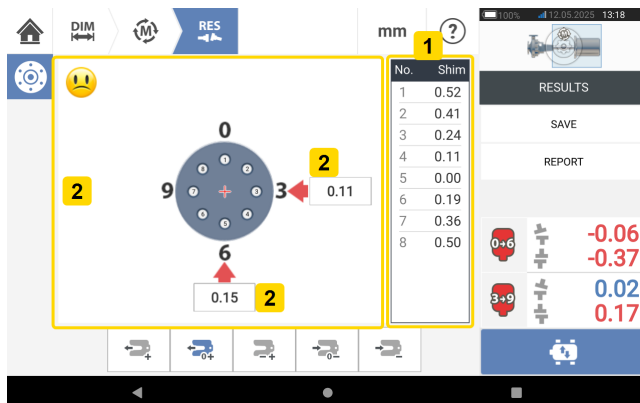

- **(1)** To correct angularity, shim at the given bolt locations.
- **(2)** To correct offset, move the machine laterally.

### Correct angularity

It is recommended (but not necessary) to correct angularity first:

1. Loosen the flange bolts then lift the movable machine.



#### **WARNING**

The machine bolts must be undamaged and removable.

2. Angularity corrections are made by shimming. The shimming values at the respective bolt positions are shown on the screen. Insert (or remove) shims with the correct thickness under the selected bolt. (Refer to shimming modes in related topics.)

3. Tighten the bolts back down, then take another set of readings to confirm shimming corrections; repeat shimming if necessary.

4. Once satisfied that overall angular misalignment is in tolerance, and no more shimming is required, proceed to correct offset.

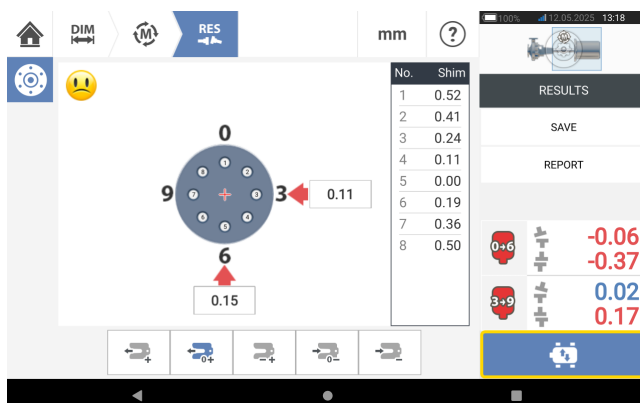

### Correct offset

1. Use the Live Move function to correct offset.



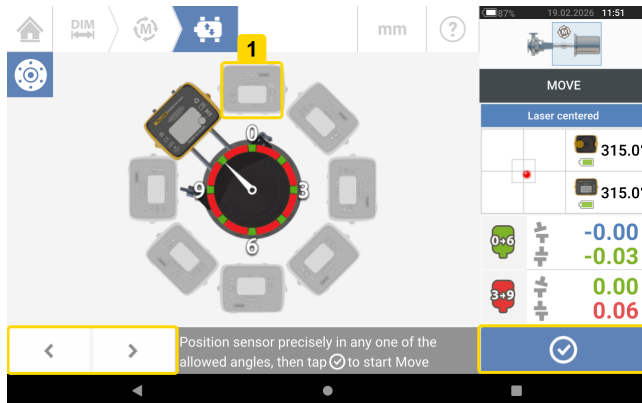

2. Tap  to start Live Move. A hint screen to position both sensor and laser in any one of the eight designated 45° positions (12:00, 1:30, 3:00, 4:30, 6:00, 7:30, 9:00 or 10:30 o'clock position – as viewed from sensor towards laser) is shown.



3. Use  and  to place the displayed sensor at the necessary 45° position. Alternatively, tap necessary position (for example **1**) to move the sensor on the screen to this position (**1**). This position is the same as the angular position of the sensor and laser on the shafts. In this example, 12:00 o'clock is the selected angular position for sensor and laser.

Tap  to continue.



- **(1)** Arrows show direction and magnitude to move machine
- **(2)** Tolerance coded gap and offset coupling values
- **(3)** Tap  to measure again or to start Live Move again
- **(4)** Tap  to measure again or to start Live Move again

4. Loosen the flange bolts then move the machine laterally in the direction of the color coded bold arrows to perform offset corrections.

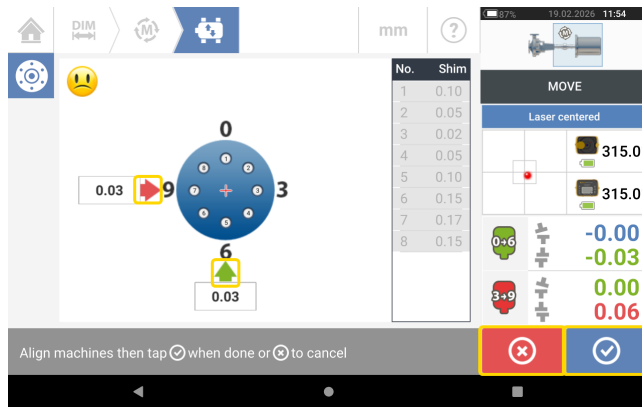



Once Live Move has been detected, the **Cancel** icon  replaces the **Undo** icon .

If you tap , the hint **Cancel Move** is shown.

The color coded bold arrows show coupling tolerance as follows: Blue (excellent condition); Green (good condition) and Red (poor condition). The color of the arrows changes with the movements automatically. Monitor the arrows on the Live Move screen.

- Corrections should be brought as close as possible to zero.
- Use appropriate tools (e.g. jackscrews) to position the machine.
- Take care not to let the shims slip out of place during lateral positioning.



5. When offset is in tolerance as shown by a happy smiley  (excellent tolerance) or an OK icon , tighten the flange bolts then tap  and measure again to check and confirm if the new alignment condition is in tolerance.

6. If not, repeat the above steps until alignment is in tolerance.

## Horizontal flanged machines

### Flange-mounted horizontal machines

When machines are joined by means of flange, their alignment is determined by inserting the proper combination of shims at the flange bolts and, depending on the flange type, between the faces of the flanges. The requirements are similar to those for aligning vertical machines. When the shaft rotates around a horizontal axis, the electronic inclinometer detects the rotational position during measurement, which may be taken in any necessary measurement mode.

Based on the measurements taken, the touch device determines the thicknesses of shims to be fitted between the flanges required to align the shafts.

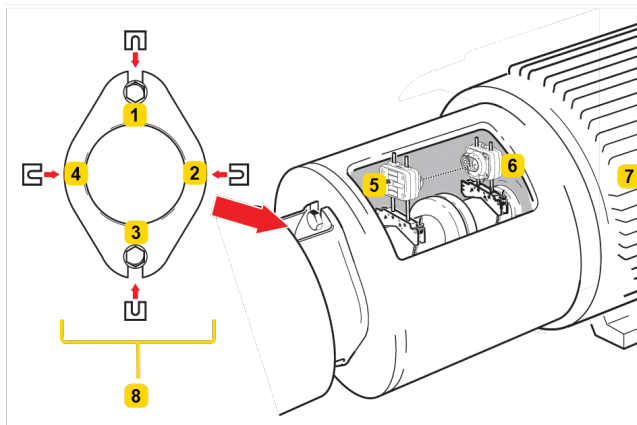

- **(1) – (4)** Flange shimming positions
- **(5)** Laser
- **(6)** Sensor
- **(7)** Machine to be aligned
- **(8)** End view of flange (as seen from left)

Shown here are the shimming locations for a two-bolt flange, a special case of the normal circular flange shape.

### Set-up

- Mount the laser and the sensor as required (horizontally).
- Switch the device on, then tap the **Vertical alignment** icon in the home screen.

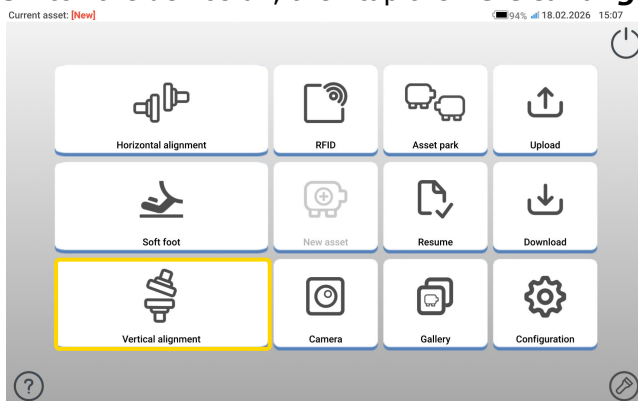

- Proceed to configure the machines as described in Vertical flanged machines.

- Due to the horizontal mounting of both sensor and laser, all related horizontal shaft alignment measurement modes are available once the sensor has been initialized.

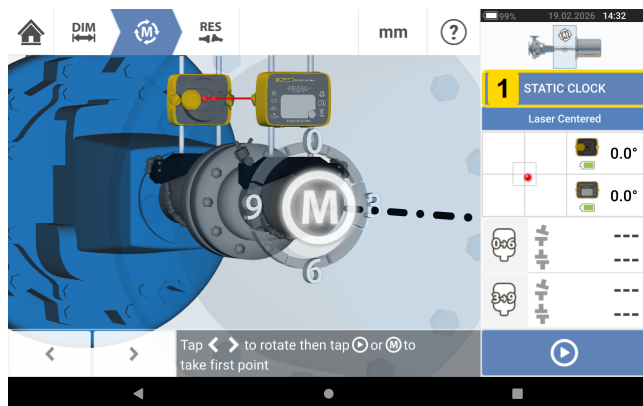

- Tap **1** and select the necessary measurement mode then proceed to carry out measurement. (See Measurement modes).





The coupling results icons for the horizontal flange application show 0-6 (for **V**ertical) and 3-9 (for **H**orizontal).

## Core sensor firmware update

### Update sensor firmware to a newer version

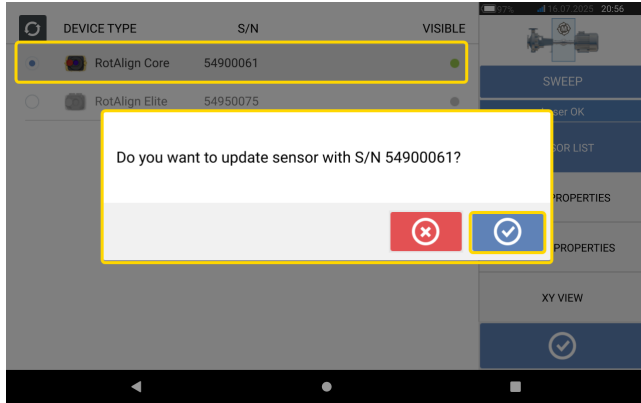
It is possible to carry out a sensor firmware update directly via the rugged touch device. If a sensor with an older firmware version is connected via Bluetooth to the rugged device, a sensor firmware update notification appears on the display.



It is recommended to update the sensor firmware. Tap  to proceed to update the sensor. The sensor firmware update screen is shown.

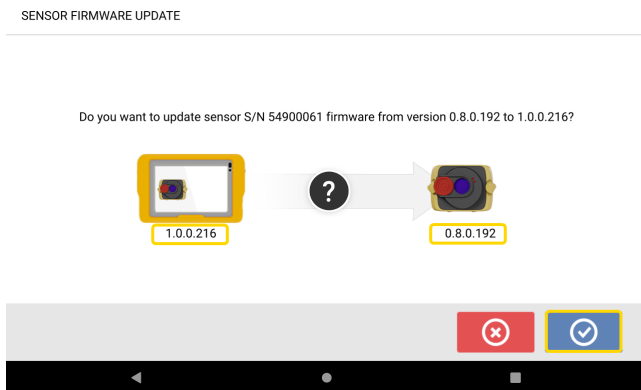

The screen shows that a newer sensor firmware version is available within the rugged touch device. Tap  to update the sensor connected via Bluetooth.

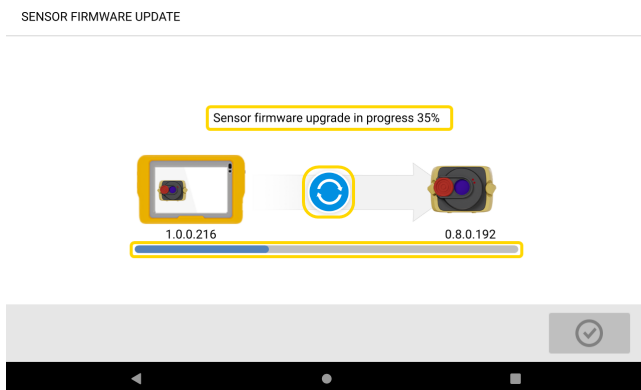

When the update process is successfully completed, this screen is shown.

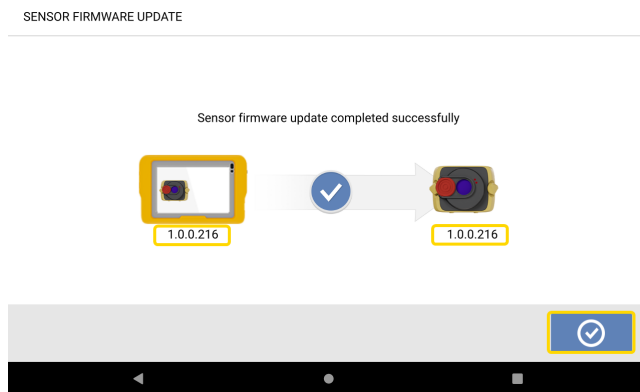

The sensor has now been updated to the newer version available on the rugged touch device.

Tap  to exit the update screen.



The new sensor firmware version appears under **Sensor properties**. Tap either sensor area **(1)** on the measurement screen to show sensor properties.

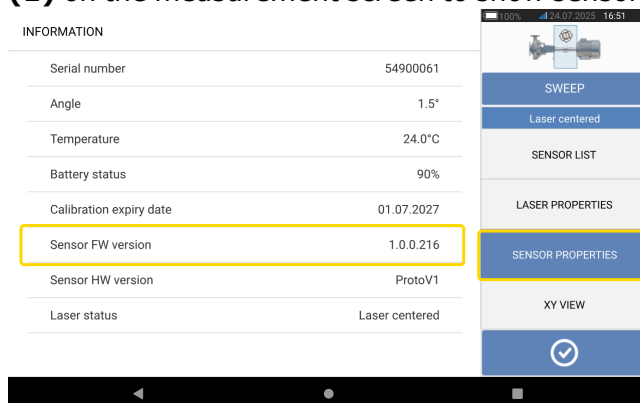

If the sensor firmware update is not done when the notification appears, the update can be started through **Sensor properties**. A hint is shown next to the older sensor firmware version.

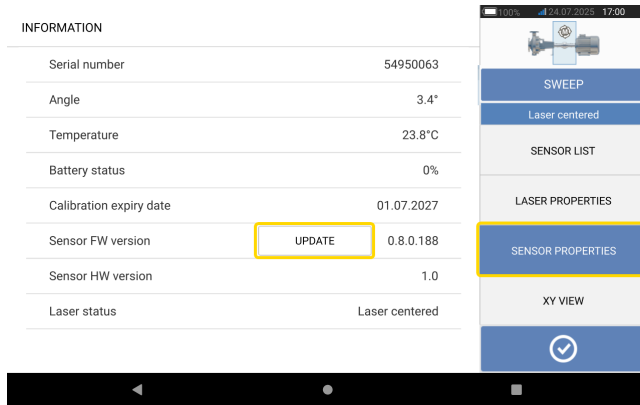

Tap **UPDATE** to proceed with the sensor firmware update.



**Note**

The sensor firmware update notification continues to appear once per day until the firmware update is completed.

**Notification on sensor and laser calibration**



**Note**

The calibration accuracy of both the sensor and the laser should be checked every two years as indicated on the round label affixed to the back of the respective component. Both sensor and laser should be returned to an authorized Fluke service center for calibration checking and inspection. You may contact your local Fluke representative for assistance or visit [www.pruftechnik.com](http://www.pruftechnik.com).



**Note**

The sensor calibration due date is also found under **Sensor properties**.

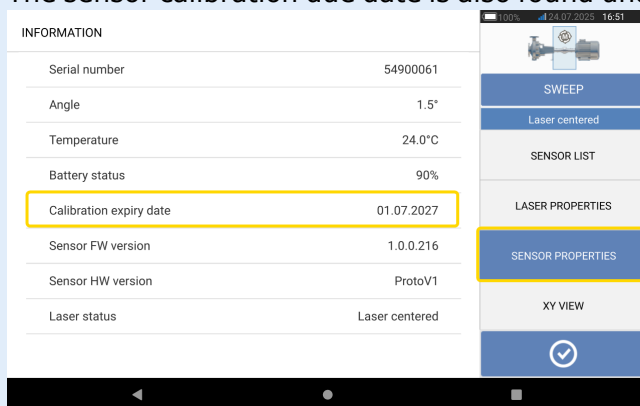

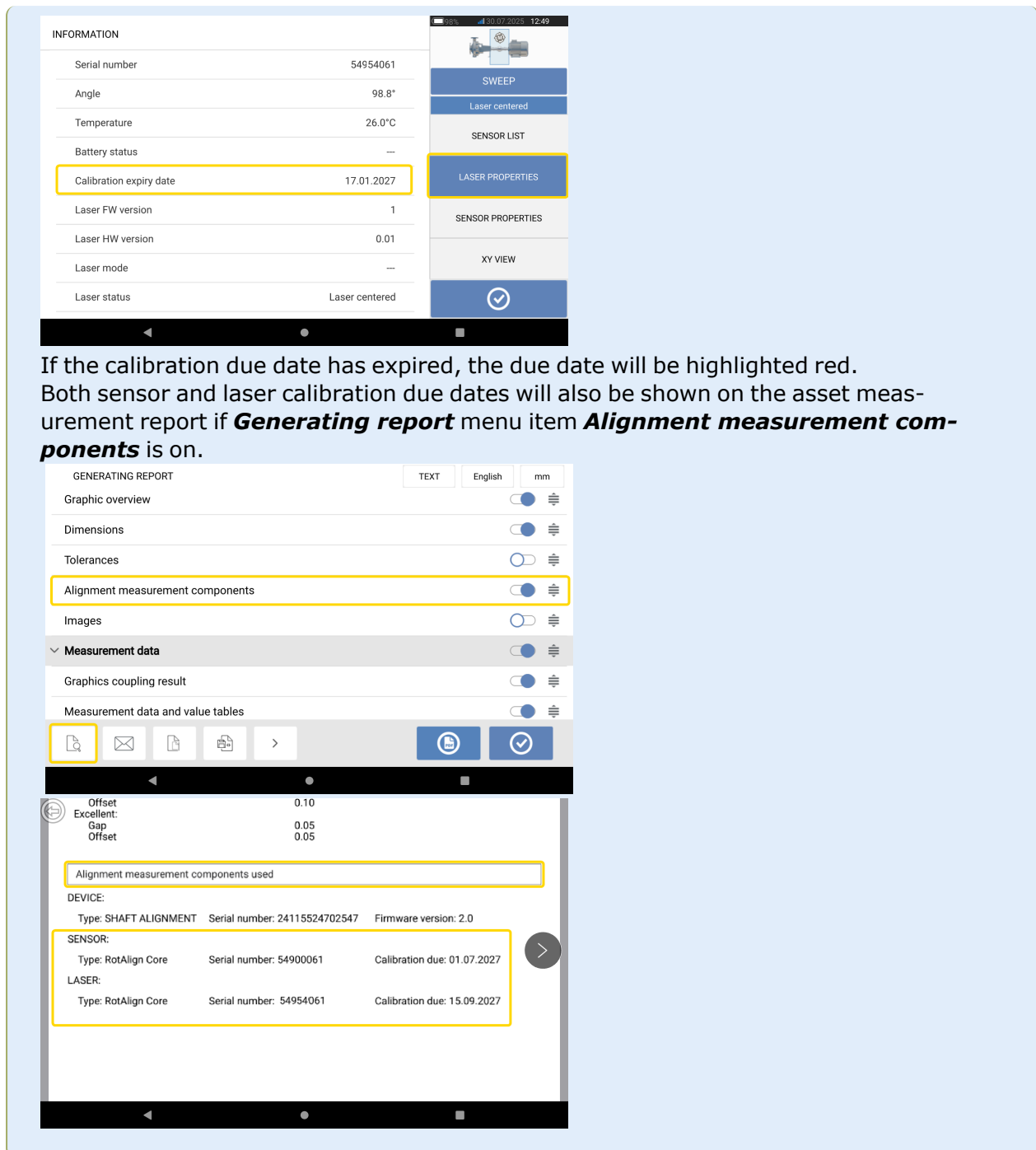

The laser inspection due date is also found under **Laser properties**.

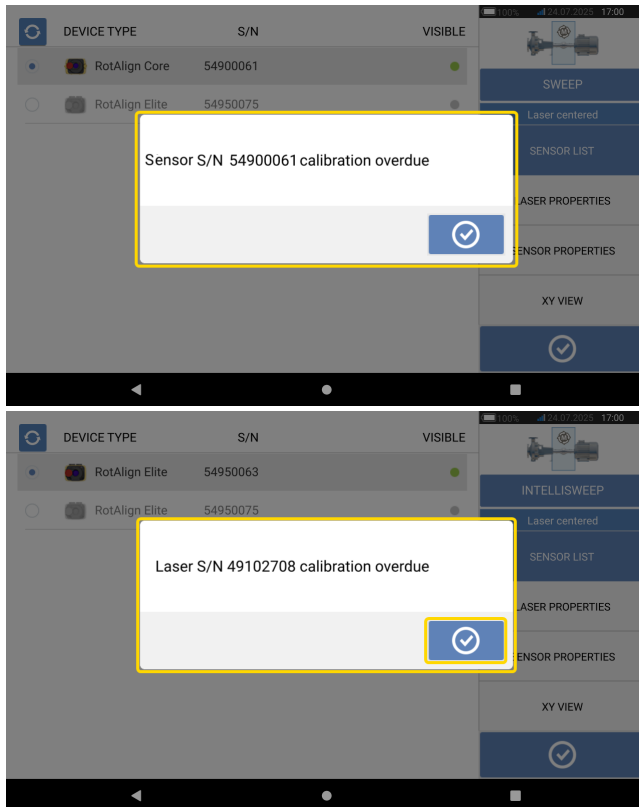

If the calibration due date has expired, the due date will be highlighted red. Both sensor and laser calibration due dates will also be shown on the asset measurement report if **Generating report** menu item **Alignment measurement components** is on.

If the calibration due date of sensor and/or laser have expired and the components are connected via Bluetooth to the rugged touch device, the related calibration expiry notification is shown on the screen.



Tap  to close the notification.

## Best practice

### Mount sensor and laser

- The dimensions screen shows the sides where the sensor and laser are to be mounted. If necessary, use , the camera icon to rotate the view on the screen to allow machines be viewed as they physically appear.
- Mount the brackets directly on the shafts or couplings.
- Mount sensor and laser as low as possible on the supplied support posts. The couplings must not block the path of the laser beam.
- Mount laser on the machine designated stationary and sensor on the machine designated moveable.
- Both sensor and laser must not touch one another or the machine casings during shaft rotation.

### Enter dimensions

- Dimensions measured to within  $\pm 3$  mm ( $\pm 1/8$  in.) using a tape measure with 1 mm ( or 1/32 in.) divisions are acceptable.
- When entering the dimension between the front and back feet, use the distance between the center of the two foot bolts.
- When dimensions are measured from the sensor, and an industrial tape measure is used, insert the hook in the slot (**1**) at the top of the sensor.



### Initializing sensor

- Should communication error occur, tap detector area below the hint **Communication error** then tap **SENSOR LIST** to check whether the sensor has been detected.
- Any new Bluetooth connection must initially be scanned before communication between sensor and the rugged device can be established. Tap  (**1**) to start to scan.

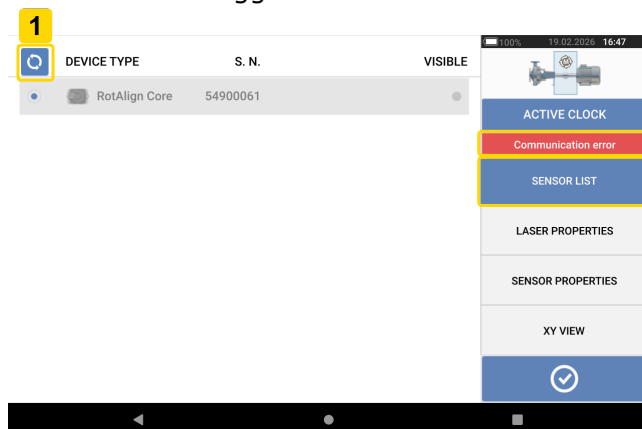

## Causes that can influence measurement

- Incorrect or loosely mounted bracket frame and/or support posts
- Incorrect or loosely mounted sensor and/or laser on the support posts
- Loose machine anchor bolts
- Unstable or damaged machine foundation
- Mounted components strike machine foundation or machine casings or frame during shaft rotation
- High breakaway torque from rotatable and non-rotatable shafts
- Coupling backlash
- Change of rotational direction during and between measurements
- Mounted components moved during shaft rotation
- Uneven shaft rotation
- Change in temperature within machines
- External vibration from other rotating machines

## Results and Live Move

- V is the vertical orientation of the machines viewed from the side.
- H is the horizontal orientation of the machines viewed from the top.
- The foot results which are used for misalignment correction, are position values with respect to the reference machine.
- The bold colored foot tolerance arrows show the direction and magnitude in which to move the machine. The color code also shows the alignment tolerance.

## Appendix

### Update device to a newer firmware version

Check the website [www.pruftechnik.com](http://www.pruftechnik.com) to obtain the latest version. If in doubt, please contact your local representative or Fluke.

- Download the update file to the necessary directory on a PC.

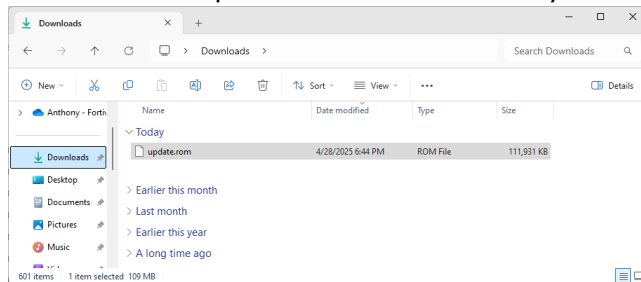

- Switch the rugged device on then connect it to the PC. A hint to allow the Windows PC access the rugged device appears.
- On confirmation, the rugged device shows up in the File Explorer.

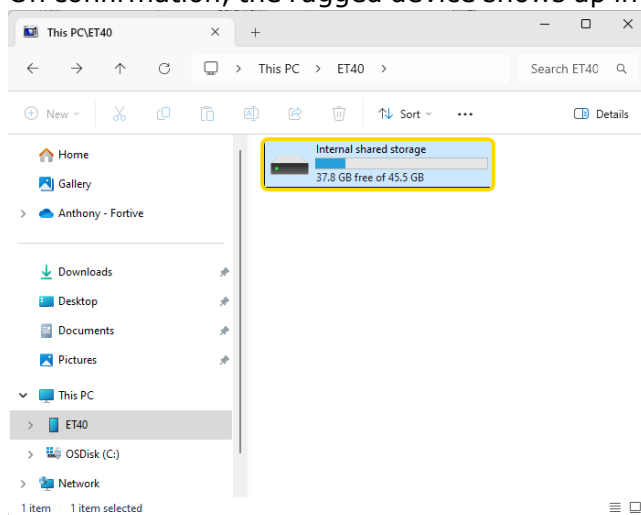

- Double-click **Internal storage** to access folders in the rugged device.

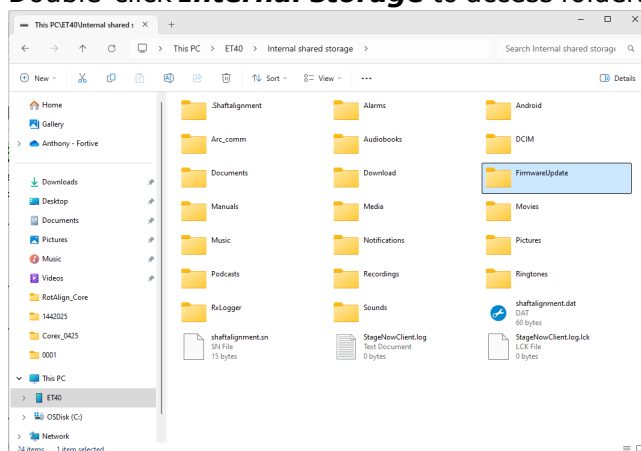

- Transfer the **update.rom** file to the rugged device folder **FirmwareUpdate**.

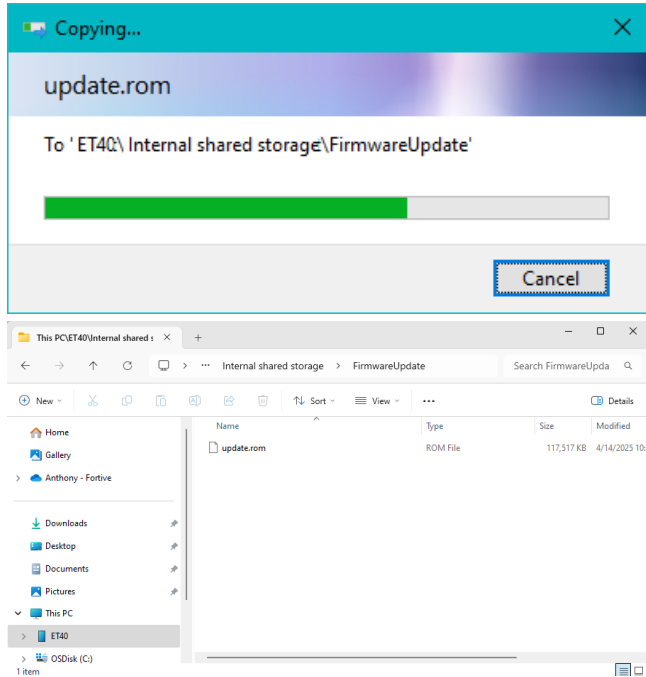

- After the update file has been copied to the **FirmwareUpdate** folder, disconnect the rugged device from the PC. This hint is shown.

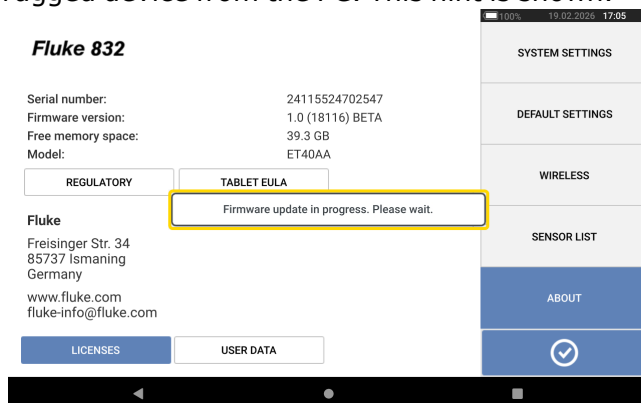

 **Note**  
DO NOT tap the device or press any of the hard keys. Wait for the next hint to appear.

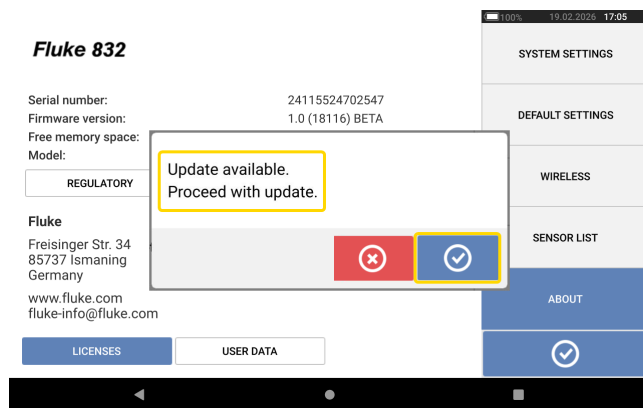

- Tap  to proceed with the firmware update



### Note

Follow all the update instructions carefully, and confirm all requested installations.

- Once the update is completed, a hint to restart the tablet device appears.

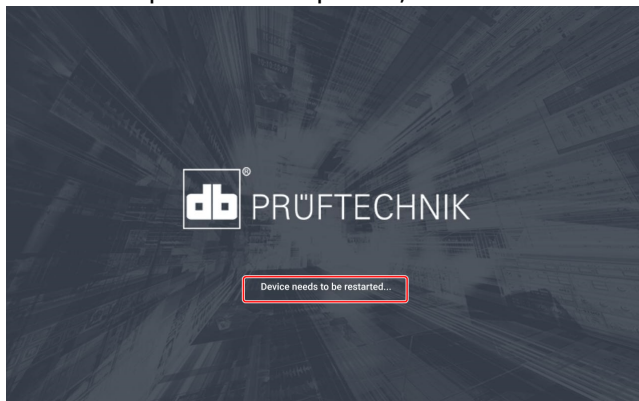

- Press and hold down the power key briefly. **Power off** and **Restart** icons appear on the display.
- Tap **Restart**. The update is now completed and may be checked and confirmed in the **ABOUT** menu item in configuration after the restart.

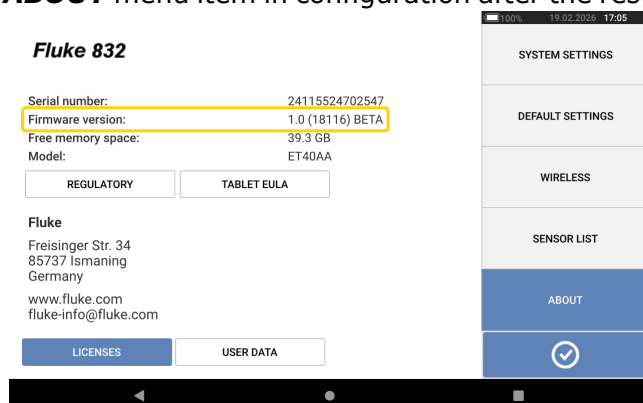

## Documentation

This on-board help and other relevant and related customer documents are saved as PDF files in the folder **Manuals** within the ruggedized tablet. To access this folder, the ruggedized tablet

is connected to a Windows PC. Allow the Windows PC to access the ruggedized tablet and then double-click **Internal storage** to access the required folder.

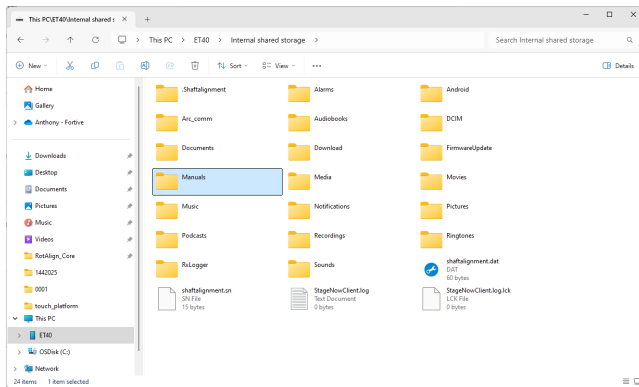

The content in this document is available also on the rugged device as context sensitive help.

Tap the question mark icon  wherever it is available to show the context sensitive help.

## Technical data – Rugged tablet

832 rugged tablet	
CPU	Processor: Octa-Core (8): 2.2 GHz (2) and 1.8 GHz (6) Memory: 4 GB LPDDR4X SDRAM/64 GB UFS Flash
Display	Corning® Gorilla® Glass Resolution: 1280 x 800 Pixel Size: 203.1 mm (8")
Connectivity	Wi-Fi: IEEE 802.11 a/b/g/n/ac/d/h/i/r/k/v/w/mc/ax 2x2 MU-MIMO; Wi-Fi® certified; IPv4, IPv6 (Wi-Fi 6) Bluetooth Version: 5.1 / 2.1+EDR Class 2 (Bluetooth LE) RFID
Camera	Main Camera - Resolution: 13.0 MP Auto Focus Front Camera - Resolution: 5.0 MP
Environmental protection	IP65 (dustproof, water jets resistant)
Temperature range	Operation: -20°C to 50°C (-4°F to 122°F) Storage: -40°C to 70°C (-40°F to 158°F)
Battery	Type: Li-ion Polymer rechargeable battery 3.87 V / 6100 mAh / 23.61 Wh Operating time: Up to 11 hours
Dimensions	Approx. 267 x 171 x 35 mm (10 33/64" x 6 47/64" x 1 3/8")
Weight (with hand straps)	Approx. 930 g (2.1 lbs)

## Technical data – Core sensor

Core sensor ALI 54.900	
Type	6-axis sensor: 2 planes (4 displacement axes and 2 angles) Measurement area: Unlimited, dynamically extendable Measurement resolution: 1 $\mu\text{m}$ (0.04 mil) and angular 10 $\mu\text{Rad}$ Transmitted measurement rate: Approx. 20 Hz Measurement error: <2% Optical measurement range: 14 x 14 mm (35/64" x 35/64")
Inclinometer	Resolution: 0.1° Error: Roll $\pm 1^\circ$ ; Pitch $\pm 3^\circ$
LED indicators	1 LED for laser adjustment and battery status 1 LED for BT communication
Power supply	Battery: Lithium-Ion rechargeable battery 3.7 V / 4.7 Wh Operating time (continuous use): 30 hours Charging time: 2.5 hours for up to 80%; 4 hours for up to 100% Charging supply: USB-C (5 V DC, 500 mA. Use only certified USB charger with limited power according to IEC/EN 61010-1 or LPS/PS2 output according to IEC/EN 62368-1)
External interface	Integrated low power 2.4 GHz radio (BT LE) USB 2.0 Full speed
Radio transmission distance	Up to 50 m (160 ft) direct line of sight
Environmental protection	IP 65 (dustproof and water jets resistant), shockproof Relative humidity: 10% to 90% Usage: Up to 3000 m above sea level Pollution Degree 4 (use appropriate power supply)
Ambient light protection	Yes
Temperature range	Operation: -10°C to 50°C (14°F to 122°F) Charging: 0°C to 35°C (32°F to 95°F) Storage: -20°C to 50°C (-4°F to 122°F)
Dimensions	Approx. 104 x 72 x 54 mm (4 3/32" x 2 53/64" x 2 1/8")
Weight	Approx. 231 g (8.1 oz)
CE conformity	Refer to the CE compliance certificate in <a href="http://www.pruftechnik.com">www.pruftechnik.com</a>
Country radio certifications	Approvals granted for specific regions (refer to the provided 'Safety and general information' document)

## Technical data – Core laser

Core laser ALI 54.910	
Type	Semiconductor laser diode Fixed laser
Beam divergence	0.3 mrad
Beam power	< 1mW
Wavelength	630-640 nm (red, visible)
Safety class	Class 2 according to IEC 60825-1:2014 The laser complies with 21 CFR 1040.10 and 1040.11 except for conformance with IEC 60825-1 Ed. 3., as described in Laser Notice No. 56, dated May 8, 2019. Safety precaution: Do not look into laser beam
Laser separation distance	Up to 10 m
LED indicators	1 LED for battery level and charging status
Inclinometer	Resolution: 0.1° Error: Roll $\pm 1^\circ$
Power supply	Battery: Lithium-Ion rechargeable battery 3.7 V 4.7 Wh Operating time (continuous use): 40 hours Charging time: 2.5 h for up to 80%; 4 h for up to 100% Charging supply: USB-C (5 V DC, 500 mA. Use only certified USB charger with limited power according to IEC/EN 61010-1 or LPS/PS2 output according to IEC/EN 62368-1)
Environmental protection	IP 65 (dustproof and water jets resistant), shockproof Relative humidity: 10% to 90% Usage: Up to 3000 m above sea level Pollution Degree 4 (use appropriate power supply)
Temperature range	Operation: -10°C to 50°C (14°F to 122°F) Charging: 0°C to 35°C (32°F to 95°F) Storage: -20°C to 50°C (-4°F to 122°F)
Dimensions	Approx. 101 x 75 x 37 mm (3 31/32" x 2 61/64" x 1 29/64")
Weight	Approx. 190 g (6.7 oz)
CE conformity	Refer to the CE compliance certificate in <a href="http://www.pruftechnik.com">www.pruftechnik.com</a>