

Tubular Heaters

FIREBAR® Single/Double-Ended Heaters

FIREBAR® heating elements provide added heating performance over standard round tubular heating elements—especially for immersion applications in petroleum based liquids requiring high kilowatts.

The FIREBAR's unique flat surface geometry packs more power in shorter elements and assemblies, along with a host of other performance improvements. These include:

- Minimizing coking and fluid degrading
- Enhancing the flow of fluid past the element's surface to carry heat from the sheath
- Improving heat transfer with a significantly larger boundary layer allowing much more liquid to flow up and across the sheath's surface

FIREBAR elements are available in single- and double-ended constructions with one inch or $\frac{1}{2}$ inch heights. These two configuration variables make it possible to use FIREBAR elements instead of round tubular elements in virtually all applications.

FINBAR™ is a special version of the one inch, single-ended FIREBAR. FINBAR is specially modified with fins to further increase surface area for air and gas heating applications. Details are contained in the *FINBAR* section, starting on page 110.

Double-Ended Performance Capabilities

One Inch

- Watt densities to 120 W/in² (18.6 W/cm²)
- Incoloy® sheath temperatures to 1400°F (760°C)
- 304 stainless steel sheath temperatures to 1200°F (650°C)
- Voltages to 240VAC
- Amperages to 48 amperes per heater or 16 amperes per coil

$\frac{1}{2}$ Inch

- Watt densities to 90 W/in² (13.9 W/cm²)
- Incoloy® sheath temperatures to 1400°F (760°C)
- Voltages to 240VAC
- Amperages to 32 amperes per heater or 16 amperes per coil

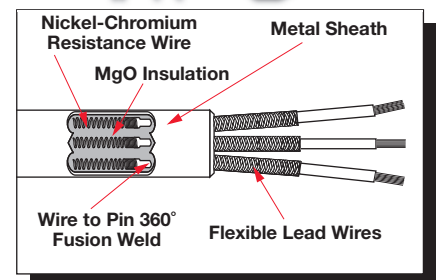
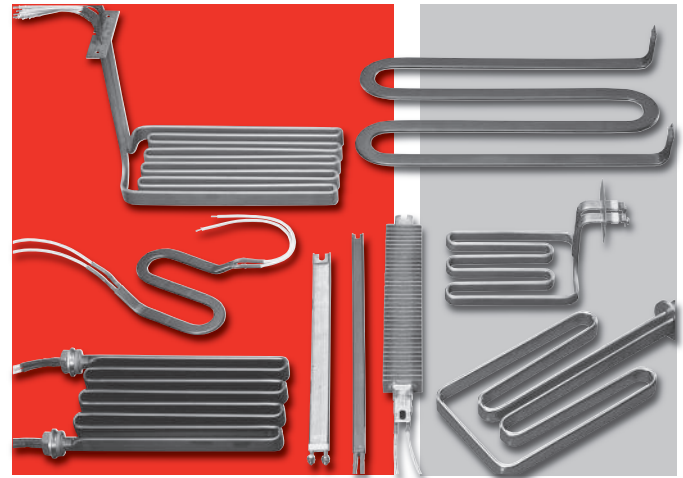

One Inch Double-Ended FIREBAR Element and Lead Configurations

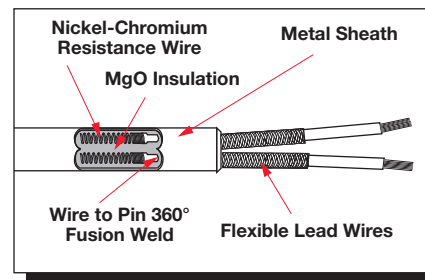

$\frac{1}{2}$ Inch Double-Ended FIREBAR Element and Lead Configurations

Single-Ended Performance Capabilities

One Inch

- Watt densities to 60 W/in² (9.3 W/cm²)
- Incoloy® sheath temperatures to 1400°F (760°C)
- 304 stainless steel sheath temperatures to 1200°F (650°C)
- Voltages to 240VAC
- Amperages to 48 amperes per heater or 16 amperes per coil

$\frac{1}{2}$ Inch

- Watt densities to 80 W/in² (12.4 W/cm²)
- Incoloy® sheath temperatures to 1400°F (760°C)
- Voltages to 240VAC
- Amperages to 16 amperes per heater

Tubular Heaters

FIREBAR Double-Ended Heaters

Specifications

One Inch FIREBAR

5/8 Inch FIREBAR



Applications	Direct immersion; water, oils, etc. Clamp-on; hoppers, griddles Forced air heating (Also see FINBAR, page 110) Radiant heating	Direct immersion; water, oils, etc. Clamp-on; hoppers, griddles Forced air heating Radiant heating
Watt Density W/in ² (W/cm ²)	Stock: up to 90 (13.9) Made-to-Order (M-t-O): up to 120 (18.6)	Stock: up to 90 (13.9) Made-to-Order (M-t-O): up to 90 (13.9)
Surface Area Per Linear In. (cm)	2.3 in ² (14.8 cm ²)	1.52 in ² (9.80 cm ²)
Cross Section Height ± 0.015/0.010 in. (0.381/0.254 mm) Thickness ± 0.005/0.001 in. (0.127/0.025 mm)	1.010 (25.7) 0.235 (5.9)	0.650 (16.5) 0.235 (5.9)
Sheath Material—Max. Operating temperature	Stock: Incoloy® 1400°F (760°C) M-t-O: Incoloy® 1400°F (760°C) 304 SS 1200°F (650°C)	Stock: Incoloy® 1400°F (760°C) M-t-O: Incoloy® 1400°F (760°C) 304 SS 1200°F (650°C)
Sheath Length in. (mm)	Stock: 15 to 114 (381 to 2896) M-t-O: 11 to 180 (280 to 4572)	Stock: 15 to 51 (381 to 1295) M-t-O: 11 to 115 (280 to 2920)
Straightness Tolerance Major axis in./ft (cm/m): Minor axis in./ft (cm/m):	0.062 (0.52) 0.062 (0.52)	0.062 (0.52) 0.062 (0.52)
No-Heat Length (Refer to page 105)	1 in. min., 12 in. max. (25/305 mm)	1 in. min., 12 in. max. (25/305 mm)
Max. Voltage—Amperage Max. Hipotential Max. Current Leakage Per Coil (cold) Max. Amperage Per Coil Phase(s) Resistance Coils	240VAC—48A 1480VAC 3mA 16A 1-ph parallel/series, 3-ph delta/wye 3 or 2	240VAC—32A 1480VAC 3mA 16A 1-ph parallel/series 2
Ohms/In./Unit ① Ohms/In./Coil ①	0.270Ω min.—2.833Ω max. 0.080Ω min.—8.500Ω max. per coil	0.040Ω min.—4.250Ω max. 0.080Ω min.—8.500Ω max. per coil
Terminations	Flexible lead wires Quick connect (spade) Screw lug (plate) Threaded stud	Flexible lead wires Quick connect (spade) Screw lug (plate) Threaded stud
Seals	Stock: Lavacone 221°F (105°C) M-t-O: Ceramic base 2800°F (1535°C) Silicone rubber 392°F (200°C) Lavacone 221°F (105°C) Epoxy resin 266/356°F (130/180°C)	Stock: Lavacone 221°F (105°C) M-t-O: Ceramic base 2800°F (1535°C) Silicone rubber 392°F (200°C) Lavacone 221°F (105°C) Epoxy resin 266/356°F (130/180°C)
Min. Axis Bending Radius in. (mm) (Do not field bend)	Major: 1 (25) Minor: 1/2 (13) 90° bend Minor: 3/2 (4) 180° bend	Major: 3/4 (19) Minor: 1/2 (13) 90° bend Minor: 3/2 (4) 180° bend
Mounting Options	Brackets (Type 1, 2 and 3) Threaded bulkhead or fitting	Brackets (Type 1, 2 and 3) Threaded bulkhead or fitting
Surface Finish Options	Bright anneal, passivation	Bright anneal, passivation
Agency Recognition	UL® Component recognition to 240VAC (File # E52951) CSA Component recognition to 240VAC (File # 31388)	UL® Component recognition to 240VAC (File # E52951) CSA Component recognition to 240VAC (File # 31388)

① Resistance values valid for three coil 1 in. (25 mm) FIREBAR only.

Tubular Heaters

FIREBAR Single-Ended Heaters

Specifications (Continued)

One Inch Single-Ended FIREBAR

5/8 Inch Single-Ended FIREBAR



Applications	Clamp-on; hoppers, griddles Forced or convection air heating (Also see FINBAR, page 110)	Clamp-on; hoppers, griddles Forced or convection air heating
Watt Density W/in ² (W/cm ²)	Stock: up to 40 (6.2) M-t-O: up to 60 (9.3)	Stock: up to 20 (3.1) M-t-O: up to 60 (12.4)
Surface Area Per Linear In. (cm)	2.3 in ² (14.8 cm ²)	1.52 in ² (9.80 cm ²)
Cross Section Height ± 0.015/0.010 in. (0.381/0.254 mm) Thickness ± 0.005/0.001 in. (0.127/0.025 mm)	1.010 (25.7) 0.235 (5.9)	0.650 (16.5) 0.235 (5.9)
Sheath Material—Max. Operating temperature	Stock: 304 SS 1200°F (650°C) M-t-O: Incoloy® 1400°F (760°C) 304 SS 1200°F (650°C)	Stock: Incoloy® 1400°F (760°C) M-t-O: Incoloy® 1400°F (760°C) 304 SS 1200°F (650°C)
Sheath Length in. (mm)	Stock: 11 to 46¼ (280 to 1175) M-t-O: 11 to 120 (280 to 3048)	Stock: 11½ to 52 (280 to 1321) M-t-O: 11 to 116 (280 to 2946)
Straightness Tolerance Major axis in./foot (cm/m): Minor axis in./foot (cm/m):	0.062 (0.52) 0.062 (0.52)	0.062 (0.52) 0.062 (0.52)
No-Heat Length (Refer to page 105) Top Cold End Bottom (blunt end) Cold End	1 in. min., 12 in. max. (25/305 mm) 1 ph- 0.5 min., 2 in. max. (13/51 mm) 3 ph- 0.75 min., 2 in. max. (19/51 mm)	1 in. min., 12 in. max. (25/305 mm) Only available at 1.25 in. N/A
Max. Voltage—Amperage Max. Hipotential Max. Current Leakage (cold) Max. Amperage Per Coil Phase(s) Resistance Coils	240VAC—48A 1480VAC 3mA 16A 1-ph, 3-ph wye 3 or 1	240VAC—16A 1480VAC 3mA 16A 1-ph 1
Ohms/In./Unit	0.200Ω min.—14.00Ω max.①	0.200Ω min.—14.00Ω max.①
Terminations	Flexible lead wires Threaded stud Quick connect (spade) Screw lug (plate)	Flexible lead wires Quick connect (spade) Screw lug (plate)
Seals	Stock: Lavacone 221°F (105°C) M-t-O: Ceramic base 2800°F (1535°C) Silicone rubber 392°F (200°C) Lavacone 221°F (105°C) Epoxy resin 266/356°F (130/180°C)	Stock: Lavacone 221°F (105°C) M-t-O: Ceramic base 2800°F (1535°C) Silicone rubber 392°F (200°C) Lavacone 221°F (105°C) Epoxy resin 266/356°F (130/180°C)
Min. Axis Bending Radius in. (mm) (Do Not Field Bend)	Major: 1 (25) Minor: ½ (13) 90° bend Minor: 5/32 (4) 180° bend	Major: ¾ (19) Minor: ½ (13) 90° bend Minor: 5/32 (4) 180° bend
Mounting Options	Bracket (Type 2) Threaded bulkhead	Bracket (Type 2) Threaded bulkhead
Surface Finish Options	Bright anneal	Bright anneal
Optional Internal Thermocouple	—	—
Single-end Configuration	Stock: Slotted M-t-O: Slotted, sealed or welded	Stock: Slotted M-t-O: Slotted, sealed or welded
Agency Recognition	UL® Component recognition to 240VAC (File # E52951) CSA Component recognition to 240VAC (File # 31388)	UL® Component recognition to 240VAC (File # E52951) CSA Component recognition to 240VAC (File # 31388)

① Based on 1-phase, single voltage heater.

Tubular Heaters

FIREBAR Single/Double-Ended Heaters

Features and Benefits

One Inch Features and Benefits

Double-Ended

Streamline, 0.235 x 1.010 in. (5.9 x 25.6 mm) normal to flow dimension

- Reduces drag

70 percent greater surface area per linear inch compared to a 0.430 in. (11 mm) diameter round tubular heater

- Reduces watt density or packs more kilowatts in smaller bundles

Compacted MgO insulation

- Maximizes thermal conductivity and dielectric strength

Nickel-chromium resistance wires

- Precision wound

0.040 in. (1 mm) thick MgO walls

- Transfers heat more efficiently away from the resistance wire to the sheath and media—conducts heat out of the element faster

Three resistance coil design

- Configurable to either one- or three-phase power, readily adapts to a variety of electrical sources and wattage outputs

Lavacone seals

- Provides protection against humid storage conditions, moisture retardant to 221°F (105°C)

Single-Ended

Single-ended termination

- Simplifies wiring and installation

Streamline, 0.235 x 1.010 in. (5.9 x 25.6 mm) normal to flow dimension

- Reduces drag

70 percent greater surface area per linear inch

- Reduces watt density from that of the 0.430 in. (11 mm) diameter round tubular

Slotted end

- Provides installation ease in clamp-on applications

Lavacone seals

- Provides protection against humid storage conditions, moisture retardant to 221°F (105°C)

5/8 inch Features and Benefits

Double-Ended

Special sheath dimensions, 0.235 x 0.650 in. (5.9 x 16.5 mm)

- Results in a lower profile heater

10 percent greater surface area per linear inch

- Reduces watt density from that of the 0.430 in. (11 mm) diameter round tubular heater

0.040 in. (1 mm) thick MgO walls

- Transfers heat efficiently away from the resistance wire to the heated media—conducts heat out of the element faster

Lavacone seals

- Provides protection against humid storage conditions, moisture retardant to 221°F (105°C)

Single-Ended

Single-ended termination

- Simplifies wiring and installation

Special sheath dimensions, 0.235 x 0.650 in. (5.9 x 16.5 mm)

- Results in a lower profile heater for more wattage in a smaller package

Slotted end

- Provides installation ease in clamp-on applications

Lavacone seals

- Provides protection against humid storage conditions, moisture retardant to 221°F (105°C)

Tubular Heaters

FIREBAR Single/Double-Ended Heaters

Performance Features

FIREBAR's flat tubular element geometry produces performance features and benefits not possible with traditional round tubular technology. The following describes how and why the FIREBAR is functionally superior for many applications—especially those requiring large wattage with low watt density.

By using the FIREBAR element it will:

- Lower the element's watt density
- Reduce element size and keep the same watt density
- Increase element life by reducing sheath temperature

Flat Shape Produces Lower Sheath Temperature

The FIREBAR element operates at a lower sheath temperature than a round tubular element of equal watt density because of three factors.

1. Flat Surface Geometry

FIREBAR's flat, vertical geometry is streamline. The liquid's flow past the heating element's surface is not impaired by back eddies inherent in the round tubular shape. The FIREBAR's streamline shape results in fluids flowing more freely with more heat carried away from the sheath.

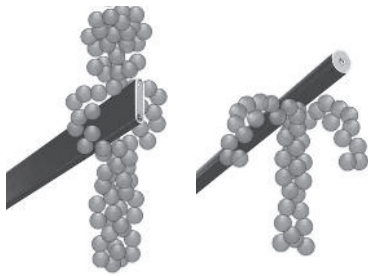

2. Normal to the Flow

The element's width (thickness) of both 1 inch and 5/8 inch FIREBAR elements is just 0.235 in. (5.9 mm). Compared to a 0.430 in. (11 mm) round tubular element, this relative thinness further reduces drag on liquids or gases flowing past the heater.

3. Buoyancy Force

The FIREBAR element's boundary layer, or vertical side, is greater than virtually all round tubular elements. This is 1.010 and 0.650 in. (25.6 and 16.5 mm) for the one inch and 5/8 in. FIREBARs respectively, compared to a 0.430 in. (11 mm) diameter on a round tubular element. The FIREBAR element's increased height, relative to flow, increases the buoyancy force in viscous liquids. This buoyancy force can be as much as 10 times greater depending on the FIREBAR element and liquid used.

Comparative Widths

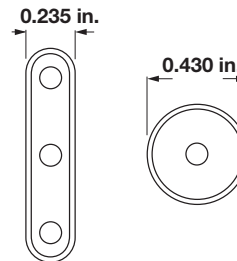

Watt Density and Surface Area Advantages

The surface area per linear inch of a 1 in. FIREBAR is 70 percent greater than the 0.430 in. (11 mm) diameter round tubular element. The 5/8 in. FIREBAR is nearly 10 percent greater.

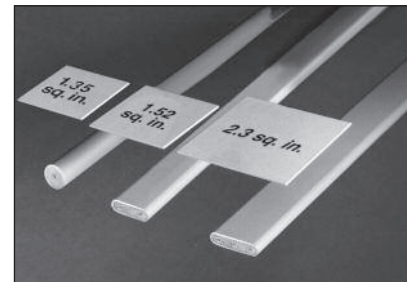

Element Type	Surface Area Per Linear Inch	
	in ²	cm ²
1 in. FIREBAR	2.30 in ²	(5.84 cm ²)
5/8 in. FIREBAR	1.52 in ²	(3.86 cm ²)
0.430 in. Round	1.35 in ²	(3.43 cm ²)

Flat vs. Round Geometry Comparisons

The unique flat surface geometry of the FIREBAR element offers more versatility in solving heater problems than the conventional round tubular element. The following comparisons show how the FIREBAR element consistently outperforms round tubular heaters. FIREBAR elements can:

- Reduce coking and fluid degrading
- Increase heater power within application space parameters
- Provide superior heat transfer in clamp-on applications resulting from greater surface area contact
- Lower watt density

Reducing watt density or sheath temperature extends life. The FIREBAR element allows you to do either, without sacrificing equipment performance ... as is proven by the accompanying *Heater Oil Test, Air Flow and Watt Density vs. Sheath Temperature* graphs.

Tubular Heaters

FIREBAR Single/Double-Ended Heaters

Technical Data

The *FIREBAR Heater Oil Test* graph compares sheath temperatures of 40 W/in² (6.7 W/cm²) flat and round tubular elements. The FIREBAR element consistently operates at a lower sheath temperature than the round tubular element, even when light oils are tested at different temperatures. This reduces the chance that coking and fluid degradation will occur.

In fact, the FIREBAR element's sheath temperature at 40 W/in² (6.7 W/cm²) is lower than a 30 W/in² (4.6 W/cm²) round tubular element.

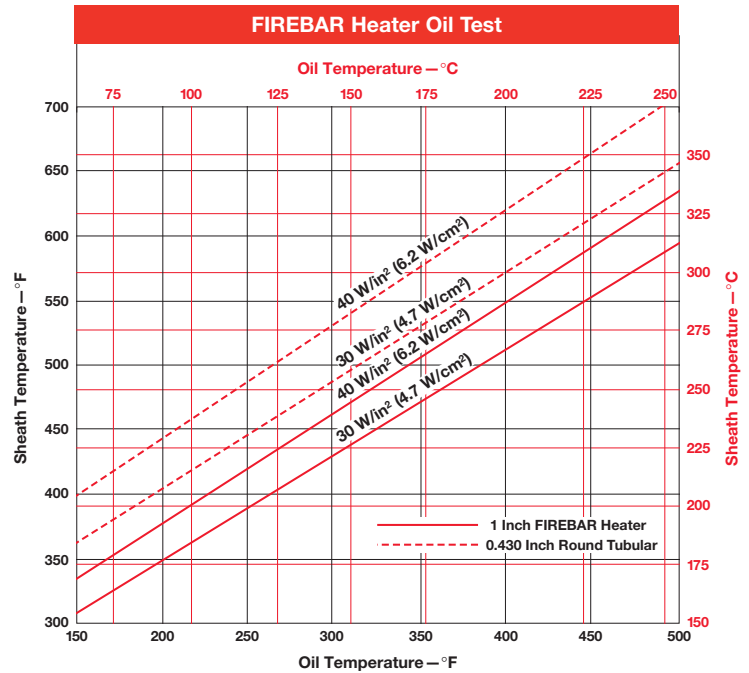

Heater Size and Power

The *Heater Size Comparison* chart shows, at the same wattage and watt density, the FIREBAR element is 38 percent shorter than a 0.430 in. (11 mm) round tubular element. The FIREBAR element requires less space in application and equipment designs.

Heater Size Comparison

Element	Heated Length in. (mm)	Wattage	W/in ²	(W/cm ²)
1 in. FIREBAR Element	19 7/8 (504.8)	1000	23	(3.6)
0.430 in. Round Tubular Element	32 1/4 (819.0)	1000	23	(3.6)

The *Heater Power Comparison* chart demonstrates equal watt density, element length and increased total wattage for the FIREBAR element. The power in the FIREBAR element is 70 percent greater.

Heater Power Comparison

Element	Heated Length in. (mm)	Wattage	W/in ²	(W/cm ²)
1 in. FIREBAR Element	32 1/4 (819.0)	1700	23	(3.6)
0.430 in. Round Tubular Element	32 1/4 (819.0)	1000	23	(3.6)

Tubular Heaters

FIREBAR Single/Double-Ended Heaters

Technical Data (Continued)

Clamp-On Applications

Direct immersion in the liquid may not always be practical. In these instances the FIREBAR element can be clamped to a tank wall. Heat from the FIREBAR is conducted to the tank wall and into the media.

FIREBAR elements are also economical platen heaters. The *Platen Heating* graph shows FIREBAR's large, flat surface area allows it to operate at twice the watt density of round tubular elements ... without sacrificing heater life.

Clamps should be placed approximately 6 in. (150 mm) apart and torqued down with 60 in-lbs (6.8 Newton meters).

Platen Heating (°F)

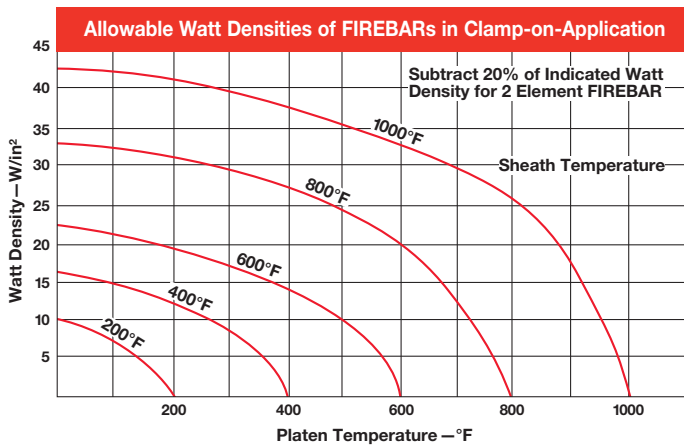

Platen Heating (°C)

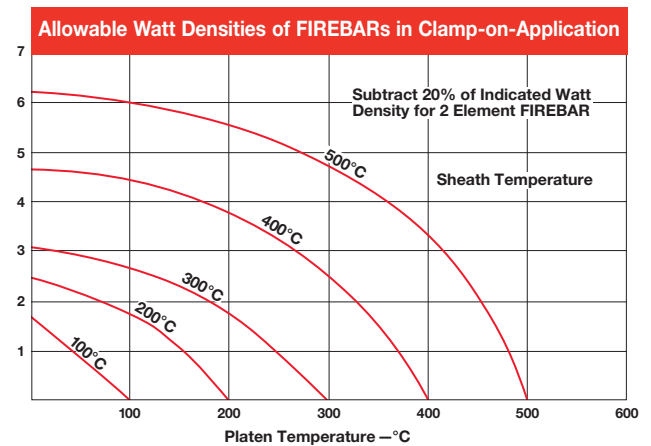

Watt Density vs. Sheath Temperature

The *Watt Density vs. Sheath Temperature* graph features sheath temperature curves for commonly heated substances. A FIREBAR element's watt density will result in the sheath temperature shown at the intersecting point of its vertical watt density line and substance curve.

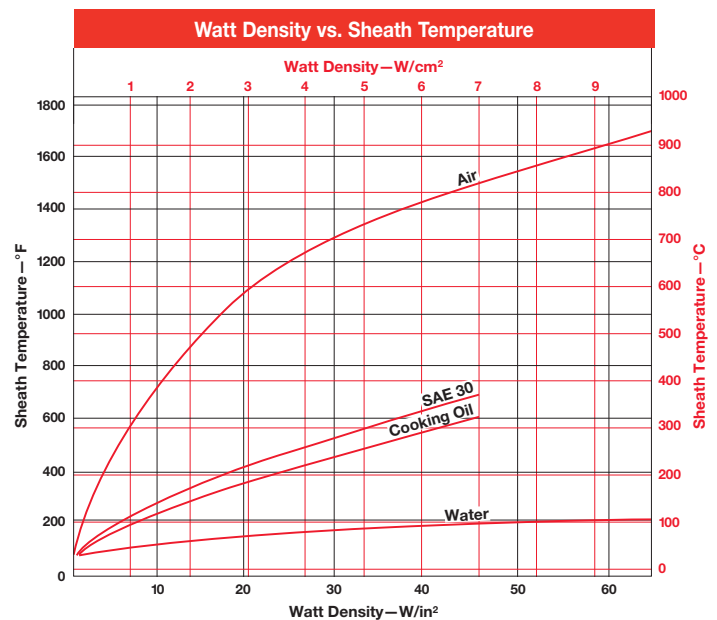

Tubular Heaters

FIREBAR Single/Double-Ended Heaters

Technical Data (Continued)

Air Heating

The Air Flow/Watt Density/Sheath Temperature graph shows the relationship between air flow, watt density and sheath temperature. Keep in mind that lower sheath temperature yields longer heater life.

To use the Air Flow graph, determine the air flow in feet per second (or meters per second). Then follow the curve to find the recommended sheath temperature and watt density.



Air Flow Normal to Sheath Geometry

Air Flow/Watt Density/Sheath Temperature (°F)

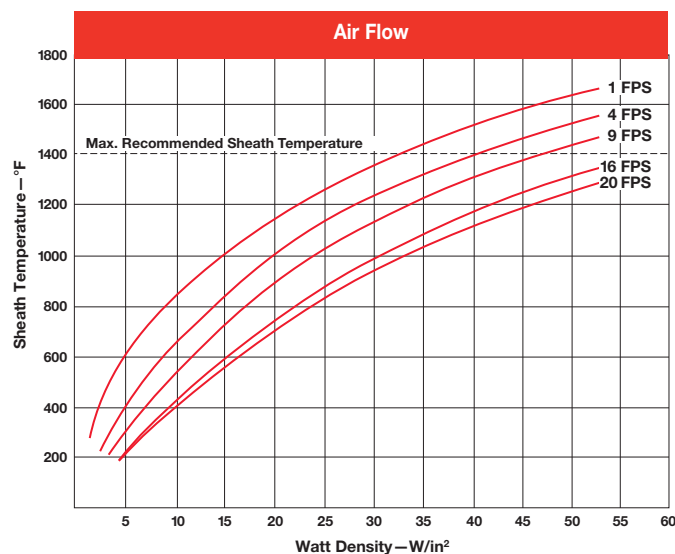

Air Flow/Watt Density/Sheath Temperature (°C)

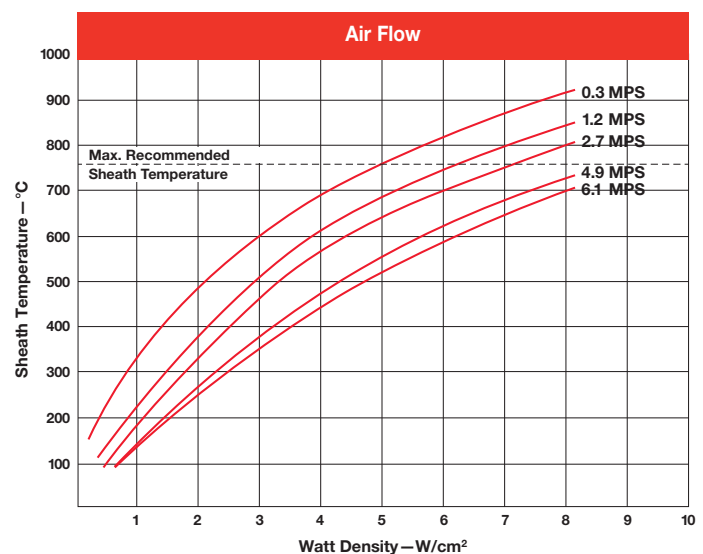

Moisture Resistant Seals

A lavacone seal is provided to prevent moisture and contaminants from entering the heater. Upon request, optional silicone rubber (RTV) and epoxy resin seals may be ordered.

Silicone Rubber (RTV) Seal

Silicone rubber RTV seals are 1/8 in. (3.2 mm) moisture barriers surrounding the terminal pins at the end of the sheath. Silicone rubber is effective to 392°F (200°C).

Epoxy Resin Seal

Epoxy resin seals are 1/8 in. (3.2 mm) moisture barriers surrounding the terminal pins at the end of the sheath. Epoxy resin is effective to 194°F (90°C) or 356°F (180°C), and recommended for water heating applications.

Application Hints

- Choose a FIREBAR heating element instead of an assembly, when the application requires lower wattages or smaller system packages.
- Keep terminations clean, dry and tight.
- Extend the heated section completely into the media being heated at all times to maximize heat transfer and heater life.
- Do not locate the end of the heated length within a bend, unless the radius is 3 in. (76 mm) or larger.
- Ensure termination temperatures do not exceed 392°F (200°C) or the maximum temperature rating of the end seal, whichever is lower.

Tubular Heaters

FIREBAR Single/Double-Ended Heaters

All FIREBAR heaters are available with a variety of termination options. Contact your Watlow representative for availability.

Technical Data (Continued)

Terminations

Code Number*	Termination	Phase	Wiring	1 in. FIREBAR		5/8 in. FIREBAR	
				Dual-Ended	S. End/FINBAR	Dual-Ended	Single-Ended
A1	Sil-A-Blend™ 200°C lead wire	1	Parallel	Yes	Yes	Yes	Yes
A2	Sil-A-Blend™ 200°C lead wire	1	Series	Yes	No	Yes	No
A3	Sil-A-Blend™ 200°C lead wire	3	Delta	Yes	No	No	No
A4	Sil-A-Blend™ 200°C lead wire	3	Wye	Yes	Yes	No	No
B1	TGGT 250°C lead wire	1	Parallel	Yes	Yes	Yes	Yes
B2	TGGT 250°C lead wire	1	Series	Yes	No	Yes	No
B3	TGGT 250°C lead wire	3	Delta	Yes	No	No	No
B4	TGGT 250°C lead wire	3	Wye	Yes	Yes	No	No
C1	1/4 in. quick connect (spade)	1	Parallel	Yes	Yes	Yes	Yes
C2	1/4 in. quick connect (spade)	1	Series	Yes	No	No	No
D1	Screw lug (plate) terminal	1	Parallel	Yes	Yes	Yes	Yes
D2	Screw lug (plate) terminal	1	Series	Yes	No	No	No
D3	Screw lug (plate) terminal	3	Delta	Yes	No	No	No
E1	#10-32 stud terminal	1	Parallel	Yes	Yes	Yes	Yes
E2	#10-32 stud terminal	1	Series	Yes	No	No	No
E3	#10-32 stud terminal	3	Delta	Yes	No	No	No

Termination Code Number Legend*

- A = Silicone rubber insulation (Sil-A-Blend™) with fiberglass oversleeves Rated to 392°F (200°C)
- B = High-temperature TGGT insulation with fiberglass oversleeves Rated to 480°F (250°C)
- C = Nickel-plated steel quick connect

- D = Nickel-plated steel screw lug with ceramic insulator and plated steel screw
- E = #10-32 nickel-plated steel threaded stud with plated steel nuts and washers

Electrical Configuration

- 1 = 1-phase parallel, 2 = 1-phase series, 3 = 3-phase delta, 4 = 3-phase wye

Double-End FIREBAR

Flexible Lead Wire^①

A, B



- Double-End 1 in. FIREBAR
- Single-End 1 in. FIREBAR
- FINBAR

Quick Connect (Spade)

C1

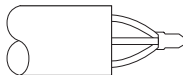

- Double-End 1 in. FIREBAR

Quick Connect (Spade)

C2

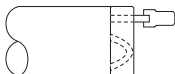

- Double-End 1 in. FIREBAR

Screw Lug (Plate)

D1

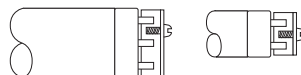

- Double-End 1 & 1/4 in. FIREBAR

Screw Lug (Plate)

D2



- Double-End 1 in. FIREBAR

Screw Lug (Plate)

D3



- Double-End 1 in. FIREBAR

3-phase delta wiring example

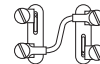

Threaded Stud

E2

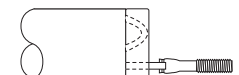

- Double-End 1 in. FIREBAR

Threaded Stud

E1

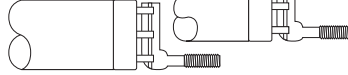

- Double-End 1 & 1/4 in. FIREBAR

Threaded Stud

E3



- Double-End 1 in. FIREBAR

3-phase delta wiring example

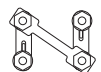

^① Flexible lead wires are 12 in. (305 mm) long unless otherwise specified.

Single-End FIREBAR

Flexible Lead Wire^①

A, B



- Single-End 1 in. FIREBAR
- Double-End 1/2 in. FIREBAR
- Single-End 3/4 in. FIREBAR
- FINBAR

Quick Connect (Spade)

C3



- Single-End 1 FIREBAR
- FINBAR
- Double-End 1/2 in. FIREBAR
- Single-End 3/4 in. FIREBAR

Screw Lug (Plate)

D4



- Single-End 1 in. FIREBAR
- FINBAR

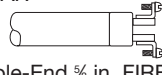

- Double-End 1/2 in. FIREBAR
- Single-End 3/4 in. FIREBAR

Threaded Stud

E4

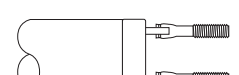

- Single-End 1 in. FIREBAR
- FINBAR

^① Flexible lead wires are 12 in. (305 mm) long unless otherwise specified.

Tubular Heaters

FIREBAR Single/Double-Ended Heaters

Bending

Major and Minor Axis Bending Parameters

The following illustrations detail the recommended major and minor axis bend parameters for FIREBAR elements. These illustrations show the relationship between the type of bend and the location of heat and no-heat sections. See the next two pages for the 15 common bend formations.

Note: Watlow does not recommend field bending FIREBAR elements. If the element must be bent in the field, please contact your Watlow representative for assistance.

180° Minor Axis Heated Bend

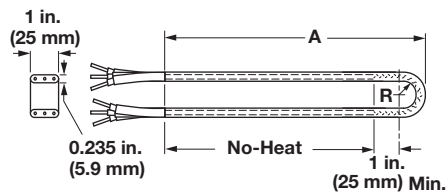

180° Major Axis Heated Bend

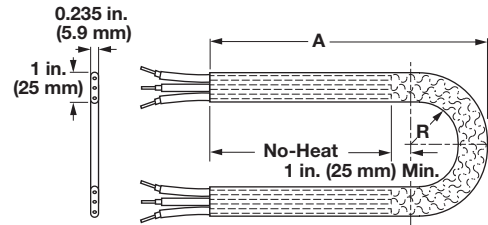

90° Minor Axis Heated Bend

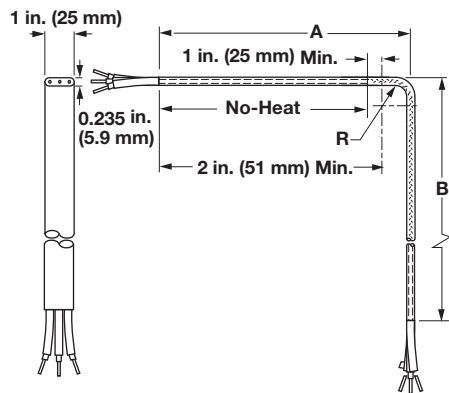

90° Major Axis Heated Bend

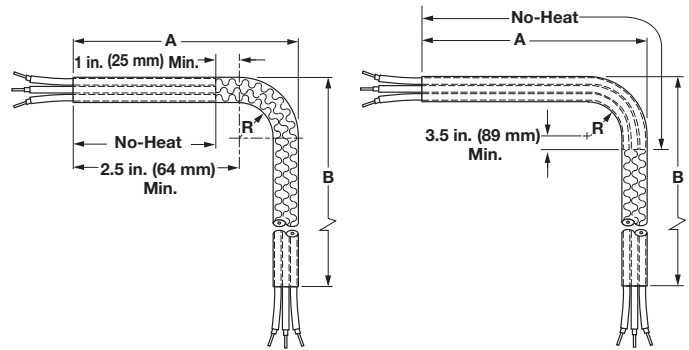

90° Minor Axis Un-Heated Bend

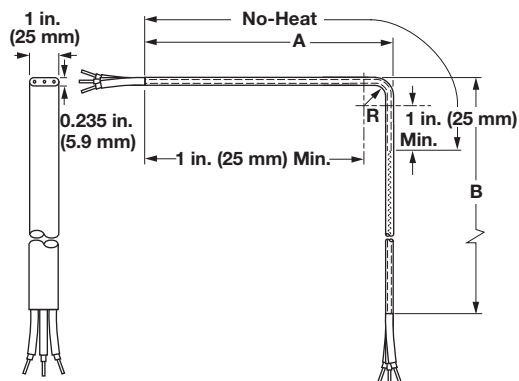

180° Major Axis Bends

FIREBAR Size		Radius		Arc Length
in.	(mm)	in.	(mm)	
3/8	(15.9)	3/8	(19.0)	3.125
3/8	(15.9)	1	(25.0)	3.900
3/8	(15.9)	1 1/4	(32.0)	4.620
3/8	(15.9)	1 1/2	(38.0)	5.600
1	(25.0)	1	(25.0)	4.335
1	(25.0)	1 1/4	(32.0)	5.121
1	(25.0)	1 1/2	(38.0)	5.906

Tubular Heaters

FIREBAR Single/Double-Ended Heaters

Bend Formations

FIREBAR elements can be formed into spirals, compounds, multi-axis and multi-plane configurations from 15 common bends. Custom bending with tighter tolerances can be made to meet specific application needs.

Formation is limited by bending parameters specified in the illustrations of major and minor axis bends on the previous page. On these illustrations, please note the no-heat end location.

The no-heat end junction must be located a minimum of 1 in. (25 mm) from any bend. If these parameters are not followed, the heater may fail prematurely.

Illustrated below are the common bends that can be ordered for all FIREBAR heating elements.

To order a common bend, specify the **figure number** and **critical dimensions**.

Note: The alpha characters and symbols are used to designate specific dimensions within each illustration.

Minor Axis	Major Axis	Minor Axis	Major Axis
Figure 1A 	Figure 1B 	Figure 2A 	Figure 2B
Figure 3A 	Figure 3B 	Figure 4A 	Figure 4B
Figure 5A 	Figure 5B 	Figure 6A 	Figure 6B
Figure 7A 	Figure 7B 	Figure 8A 	Figure 8B

Tubular Heaters

FIREBAR Single/Double-Ended Heaters

Bend Formation (Continued)

Minor Axis	Major Axis	Minor Axis	Major Axis
<p>Figure 9A</p>	<p>Figure 9B</p>	<p>Figure 10A</p>	<p>Bend Figure 10B Not Available On Major Axis</p>
<p>Figure 11A</p>	<p>Bend Figure 11B Not Available On Major Axis</p>	<p>Figure 12A</p>	<p>Figure 12B</p>
<p>Figure 13A</p>	<p>Figure 13B</p>	<p>Figure 14A</p>	<p>Figure 14B</p>
<p>Figure 15A</p>	<p>Figure 15B</p>		

Tubular Heaters

FIREBAR Single/Double-Ended Heaters

Mounting Brackets

Steel brackets provide element mounting in non-pressurized applications. In air heating applications, an 18-gauge aluminized steel bracket is press fitted to the element. A ¼ in. (6 mm) thick steel bracket is brazed or welded liquid-tight to the element for liquid heating. Upon request, stainless steel brackets can be provided. Special sizes also available.

The bracket is located ½ in. (13 mm) from the sheath's end, ⅙ in. (1.6 mm) if welded. Available on ⅝ in. (15.9 mm) FIREBAR as **made-to-order** only.

To order, specify **mounting bracket** as well as type, location, material and size.

Type 1

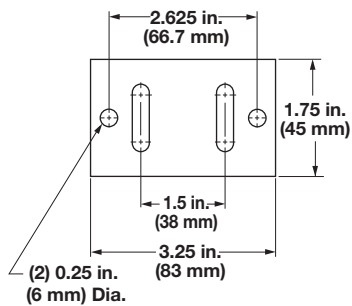

Type 2

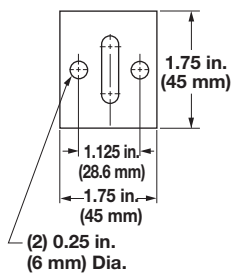

Type 3

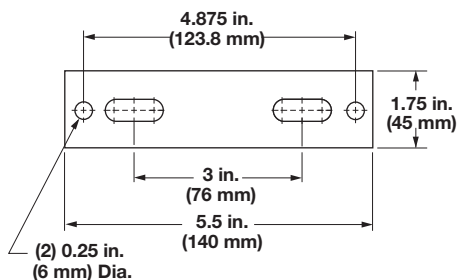

Water-Tight Double-Leg Threaded Fitting

A threaded 1 ⅝ in.-10 UNC stainless steel fitting with flange on the heater sheath provides rigid, leak-proof mounting through tank walls. This fitting allows both legs of the heater to pass through the same opening. A gasket, plated steel washer and hex nut are included. The threaded end of the bulkhead is mounted flush with the sheath's end, unless otherwise specified. Available on **1 inch FIREBAR only (brazed only, available)**.

To order, specify **water-tight double-leg threaded fitting**.

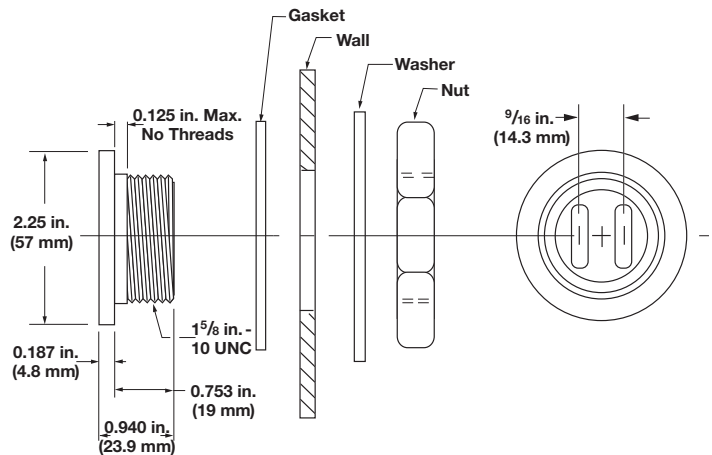

Surface Finish

Bright Annealing

Bright annealing is a process that produces a smooth, metallic finish. It is a special annealed finish created in a non-oxidizing atmosphere. This finish is popular in the pharmaceutical and foodservice/beverage markets.

To order, specify **bright annealing**.

Passivation

During manufacturing, particles of iron or tool steel may be embedded in the stainless steel or alloy sheath. If not removed, these particles may corrode and produce rust spots. For critical sheath applications, passivation will remove free iron from the sheath.

To order, specify **passivation**.

Extended Capabilities For FIREBAR Single/Double-Ended Heaters

Internal Thermocouples

To provide protection against element over-temperature conditions, 1 in. (25 mm) double-ended FIREBAR elements can be ordered with ASTM **Type K** thermocouples. This is accomplished by eliminating the center resistance coil and embedding the thermocouple junction inside the sheath. Thus, thermocouples are available only on two resistance coil, 1 in. (25 mm) FIREBAR elements.

To order, specify:

- **Type K** thermocouple
- Distance the junction is to be located from the element's end
- Lead length

Thermocouple Types

ASTM Type	Conductor Positive	Characteristics Negative	Recommended Temp. Range °F (°C)
K	Chromel® (Non-magnetic)	Alumel® (Magnetic)	0 to 2000 (-20 to 1100)

① **Type K** thermocouples are rated 32 to 2282°F (0 to 1250°C). Watlow does not recommend exceeding the temperature range shown on this chart.

Options for 5/8-Inch FIREBAR

- Electropolished finish
- Custom formations
- Cordset
- Termination overmolds (silicone or neoprene)
- Terminal enclosures (general purpose, moisture resistant, moisture/explosion resistant and explosion resistant)
- Internal thermocouple (dual end only, single or dual coil)
- Custom wattage tolerance (±5%)

Options for One-Inch FIREBAR

- Electropolished finish
- Bulkhead, single leg
- Custom formations
- Cordset
- Termination overmolds (silicone or neoprene)
- Terminal enclosures (general purpose, moisture resistant, moisture/explosion resistant and explosion resistant)
- Internal thermocouple (dual end only, single or dual coil)
- Custom wattage tolerance (±5%)

Mounting Brackets

Threaded Bulkheads

A threaded stainless steel bushing with flange on the heater sheath provides rigid, leak-proof mounting through tank walls. A gasket, plated steel washer and hex nut are included (brazed only, available).

To order, specify **threaded bulkheads**.

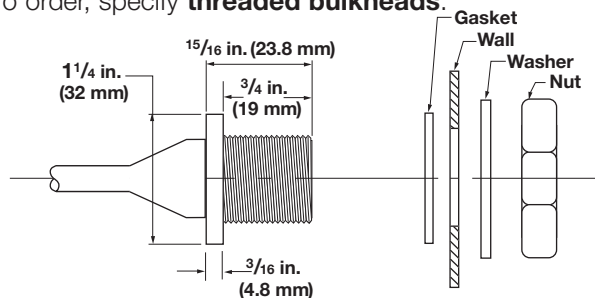

Illustration for 1-inch FIREBAR

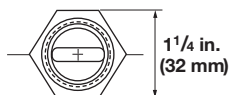

Illustration for 5/8-inch FIREBAR

Heater Size in. (mm)	Thread Size
5/8 (15.9)	5/8-14 UNF-2A
1 (25.0)	3/4-16 UNF-2A

Tubular Heaters

FIREBAR Single/Double-Ended Heaters

One-Inch, Double-Ended FIREBAR

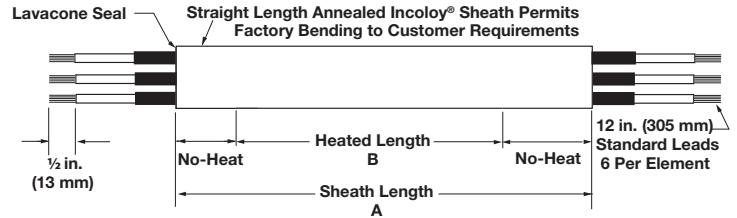

FIREBAR Description	Sheath A Dimension		Heated B Dimension		Watts	Code Number			Est. Net Wt.	
	in.	(mm)	in.	(mm)		120VAC	240VAC	480VAC	lbs	(kg)

Applications: Asphalt, Paraffin (Solid), Bunker Oil, Clamp-On

6 W/in ² Incoloy® (1 W/cm ²)	35	(889)	25	(635)	310	FBN351WD			1.3	(0.6)
	41	(1041)	31	(787)	410	FBN411WD			1.5	(0.7)
	51	(1295)	41	(1041)	530	FBN511WD	FBN5110WD		1.9	(0.9)
	62	(1574)	52	(1320)	650	FBN621WD	FBN6210WD		2.3	(1.1)
	72	(1828)	62	(1574)	800	FBN721WD	FBN7210WD		2.6	(1.2)
	93	(2362)	83	(2108)	1,060	FBN931WD	FBN9310WD		3.4	(1.6)
	114	(2895)	104	(2641)	1,350	FBN1141WD	FBN11410WD		4.2	(1.9)

Applications: Griddles, Fuel Oil, Clamp-On

10 W/in ² Incoloy® (1.6 W/cm ²)	25	(635)	22	(558)	500	FBN251WL			0.9	(0.4)
	35	(889)	32	(812)	750	FBN351WL	FBN3510WL		1.3	(0.6)
	47	(1193)	43	(1092)	1,000	FBN471WL	FBN4710WL		1.7	(0.8)
	69	(1752)	65	(1651)	1,500	FBN691WL	FBN6910WL		2.5	(1.2)
	90	(2286)	86	(2184)	2,000	FBN901WL	FBN9010WL		3.3	(1.5)

Applications: Clamp-On, Medium Weight Oils, Liquid Paraffin, Low-Temperature Ovens 400°F (205°C)

15 W/in ² Ⓛ Incoloy® (2.3 W/cm ²)	29	(736)	19	(482)	670		FBN2910WE		1.1	(0.5)
	34	(863)	24	(609)	830		FBN3410WE		1.3	(0.6)
	39	(990)	29	(736)	1,000		FBN3910WE		1.4	(0.7)
	48	(1219)	38	(965)	1,330		FBN4810WE	FBN4811WE	1.8	(0.9)
	58	(1473)	48	(1219)	1,670		FBN5810WE	FBN5811WE	2.1	(1.0)
	68	(1727)	58	(1473)	2,000		FBN6810WE	FBN6811WE	2.5	(1.2)
	87	(2209)	77	(1955)	2,670		FBN8710WE	FBN8711WE	3.2	(1.5)
	106	(2692)	96	(2438)	3,330		FBN10610WE	FBN10611WE	3.9	(1.8)

Applications: Radiant, Platens, Dies, Low-Temperature Ovens 300°F (150°C)

20 W/in ² Incoloy® (3.1 W/cm ²)	15	(381)	11	(279)	500	FBN151WM			0.6	(0.3)
	20	(508)	16	(406)	750	FBN201WM			0.8	(0.4)
	26	(660)	22	(558)	1,000	FBN261WM	FBN2610WM		1.0	(0.5)
	36	(914)	32	(812)	1,500	FBN361WM	FBN3610WM		1.3	(0.6)
	48	(1219)	43	(1092)	2,000	FBN481WM	FBN4810WM		1.8	(0.9)
	70	(1778)	65	(1651)	3,000		FBN7010WM	FBN7011WM	2.6	(1.2)
	91	(2311)	85	(2159)	4,000		FBN9110WM	FBN9111WM	3.3	(1.5)

Applications: Degreasing Solutions, Heat Transfer Oils

23 W/in ² Incoloy® (3.6 W/cm ²)	35	(889)	25	(635)	1,250	FBN351WT	FBN3510WT		1.3	(0.6)
	41	(1041)	31	(787)	1,625	FBN411WT	FBN4110WT		1.5	(0.7)
	51	(1295)	41	(1041)	2,125	FBN511WT	FBN5110WT	FBN5111WT	1.9	(0.9)
	62	(1574)	52	(1320)	2,625	FBN621WT	FBN6210WT	FBN6211WT	2.3	(1.1)
	72	(1828)	62	(1574)	3,200	FBN721WT	FBN7210WT	FBN7211WT	2.6	(1.2)
	93	(2362)	83	(2108)	4,250	FBN931WT	FBN9310WT	FBN9311WT	3.4	(1.6)
	114	(2895)	104	(2641)	5,400	FBN1141WT	FBN11410WT	FBN11411WT	4.2	(1.9)

CONTINUED

RAPID SHIP

- Available on all elements unless otherwise noted
- Same day shipment up to 15 pieces
- Ⓛ Delivery, 10 working days
- Truck Shipment only

Tubular Heaters

FIREBAR Single/Double-Ended Heaters

One-Inch, Double-Ended FIREBAR (Continued)

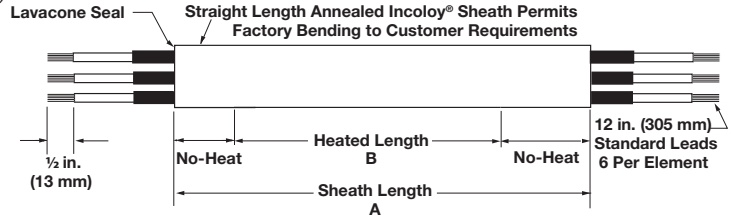

FIREBAR Description	Sheath A Dimension		Heated B Dimension		Watts	Code Number			Est. Net Wt.	
	in.	(mm)	in.	(mm)		120VAC	240VAC	480VAC	lbs	(kg)

Applications: Cooking Oils, Mild Caustic Solution, Ethylene Glycol (100%)

30 W/in ² Incoloy® (4.7 W/cm ²)	16	(406)	10	(254)	750	FBN161WH			0.6	(0.3)
	20	(508)	14	(355)	1000	FBN201WH			0.8	(0.4)
	27	(685)	21	(533)	1500	FBN271WH	FBN2710WH		1.0	(0.5)
	34	(863)	28	(711)	2000	FBN341WH	FBN3410WH		1.3	(0.6)
	50	(1270)	43	(1092)	3000		FBN5010WH	FBN5011WH	1.8	(0.9)
	64	(1625)	57	(1447)	4000		FBN6410WH	FBN6411WH	2.4	(1.1)
	80	(2032)	72	(1828)	5000		FBN8010WH	FBN8011WH	2.9	(1.4)

Applications: Process Water, Ethylene Glycol (50%)

40 W/in ² Incoloy® (6.2 W/cm ²)	25	(635)	22	(558)	2000		FBN2510WK		0.9	(0.4)
	35	(889)	32	(812)	3000		FBN3510WK	FBN3511WK	1.3	(0.6)
	47	(1193)	43	(1092)	4000		FBN4710WK	FBN4711WK	1.7	(0.8)
	69	(1752)	65	(1651)	6000		FBN6910WK	FBN6911WK	2.5	(1.2)
	90	(2286)	86	(2184)	8000		FBN9010WK	FBN9011WK	3.3	(1.5)
45 W/in ² Incoloy® (7 W/cm ²)	29	(736)	19	(482)	2000		FBN2910WP		1.1	(0.5)
	34	(863)	24	(609)	2500		FBN3410WP		1.3	(0.6)
	39	(990)	29	(736)	3000		FBN3910WP		1.4	(0.7)
	48	(1219)	38	(965)	4000		FBN4810WP	FBN4811WP	1.8	(0.9)
	58	(1473)	48	(1219)	5000		FBN5810WP	FBN5811WP	2.1	(1.0)
	68	(1727)	58	(1473)	6000		FBN6810WP	FBN6811WP	2.5	(1.2)
	87	(2209)	77	(1955)	8000		FBN8710WP	FBN8711WP	3.2	(1.5)
106	(2692)	96	(2438)	10,000		FBN10610WP	FBN10611WP	3.9	(1.8)	

Applications: Clean and Potable Water

80 W/in ² Incoloy® (12.4 W/cm ²)	15	(381)	11	(279)	2000		FBN1510WJ		0.6	(0.3)
	20	(508)	16	(406)	3000		FBN2010WJ		0.8	(0.4)
	26	(660)	22	(558)	4000		FBN2610WJ	FBN2611WJ	1.0	(0.5)
	36	(914)	32	(812)	6000		FBN3610WJ	FBN3611WJ	1.3	(0.6)
	48	(1219)	43	(1092)	8000		FBN4810WJ	FBN4811WJ	1.8	(0.9)
90 W/in ² Incoloy® (14 W/cm ²)	70	(1778)	65	(1651)	12,000			FBN7011WJ	2.6	(1.2)
	91	(2311)	85	(2159)	16,000			FBN9111WJ	3.3	(1.5)
	35	(889)	25	(635)	5000	FBN351WG	FBN3510WG	FBN3511WG	1.3	(0.6)
	41	(1041)	31	(787)	6500	FBN411WG ^①	FBN4110WG	FBN4111WG	1.5	(0.7)
	51	(1295)	41	(1041)	8500		FBN5110WG	FBN5111WG	1.9	(0.9)
	62	(1574)	52	(1320)	10,500		FBN6210WG	FBN6211WG	2.3	(1.1)
	72	(1828)	62	(1574)	12,750		FBN7210WG	FBN7211WG	2.6	(1.2)
93	(2362)	83	(2108)	17,000			FBN931WG	3.4	(1.6)	
114	(2895)	104	(2641)	21,500			FBN11411WG	3.4	(1.6)	

RAPID SHIP

- Available on all elements unless otherwise noted
- Same day shipment up to 15 pieces

① Delivery, 10 working days

Truck Shipment only

Tubular Heaters

FIREBAR Single/Double-Ended Heaters

5/8-Inch Double-Ended FIREBAR

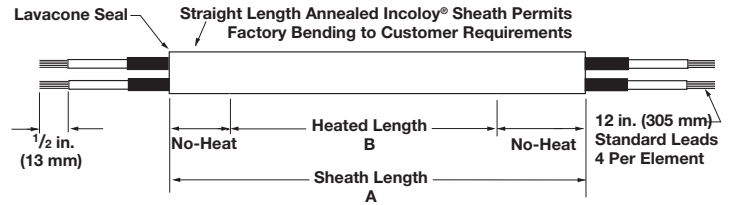

FIREBAR Description	Sheath A Dimension		Heated B Dimension		Watts	Code Number			Est. Net Wt.	
	in.	(mm)	in.	(mm)		120VAC	240VAC	480VAC	lbs	(kg)

Applications: Degreasing Fluids, Heat Transfer Oils

23 W/in² ① Incoloy® (3.6 W/cm²)	19	(483)	11	(279)	375	FAN191WT			0.5	(0.3)
	22	(559)	14	(356)	500	FAN221WT	FAN2210WT		0.5	(0.3)
	26	(660)	18	(457)	625	FAN261WT	FAN2610WT		0.6	(0.3)
	30	(762)	22	(559)	750	FAN301WT	FAN3010WT		0.7	(0.4)
	37	(940)	29	(737)	1000	FAN371WT	FAN3710WT		0.9	(0.5)
	44	(1118)	36	(914)	1250	FAN441WT	FAN4410WT		1.0	(0.5)
	51	(1295)	43	(1092)	1500	FAN511WT	FAN5110WT		1.2	(0.6)

Applications: Clean and Potable Water

90 W/in² Incoloy® (14 W/cm²)	15	(381)	7	(178)	1000	FAN151WG ①	FAN1510WG		0.4	(0.2)
	19	(483)	11	(279)	1500	FAN191WG	FAN1910WG ①	FAN1911WG	0.5	(0.3)
	22	(559)	14	(356)	2000	FAN221WG	FAN2210WG ①	FAN2211WG	0.5	(0.3)
	26	(660)	18	(457)	2500	FAN261WG	FAN2610WG ①	FAN2611WG	0.6	(0.3)
	30	(762)	22	(559)	3000	FAN301WG ①	FAN3010WG ①	FAN3011WG	0.7	(0.4)
	37	(940)	29	(737)	4000		FAN3710WG ①	FAN3711WG	0.9	(0.5)
	44	(1118)	36	(914)	5000		FAN4410WG ①	FAN4411WG	1.0	(0.5)
	51	(1295)	43	(1092)	6000		FAN5110WG ①	FAN5111WG	1.2	(0.6)

RAPID SHIP

- Available on all elements unless otherwise noted
- Same day shipment up to 15 pieces
- ① Delivery, 10 working days

Tubular Heaters

FIREBAR Single/Double-Ended Heaters

One-Inch, Single-Ended FIREBAR

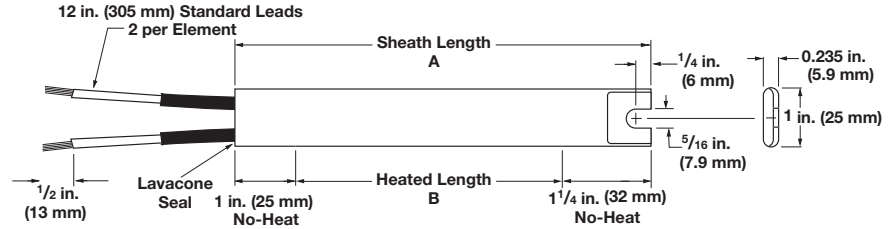

FIREBAR Description	Sheath A Dimension		Heated B Dimension		Watts	Code Number		Est. Net Wt.	
	in.	(mm)	in.	(mm)		120VAC	240VAC	lbs	(kg)

Applications: Radiant, Platens, Dies, Low-Temperature Ovens 300°F (150°C)

20 W/in ² 304 SS (3.1 W/cm ²)	8%	(222.0)	6%	(165.0)	300	FSP91WM		0.4	(0.2)
	10%	(260.0)	7%	(203.0)	375	FSP101WM		0.4	(0.2)
	12%	(311.0)	10	(254.0)	450	FSP121WM		0.5	(0.3)
	13%	(343.0)	11%	(286.0)	500	FSP141WM		0.5	(0.3)
	16%	(408.6)	13%	(352.4)	650	FSP161WM	FSP1610WM	0.6	(0.3)
	17%	(451.0)	15%	(393.0)	725	FSP181WM	FSP1810WM	0.7	(0.4)
	19%	(489.0)	17	(431.0)	800	FSP191WM	FSP1910WM	0.7	(0.4)
	22	(558.0)	19%	(502.0)	900	FSP221WM	FSP2210WM	0.8	(0.4)
	23%	(603.0)	21%	(546.0)	1,000	FSP241WM	FSP2410WM	0.9	(0.4)
	25	(635.0)	22%	(578.0)	1,050	FSP251WM	FSP2510WM	0.9	(0.4)
	28%	(727.1)	26%	(670.0)	1,250	FSP291WM	FSP2910WM	1.1	(0.5)
	31%	(803.3)	29%	(746.1)	1,350	FSP321WM	FSP3210WM	1.2	(0.6)
	34%	(866.8)	31%	(809.6)	1,500		FSP3410WM	1.3	(0.6)
	36%	(936.6)	34%	(879.5)	1,600		FSP3710WM	1.4	(0.7)
	40%	(1031.9)	38%	(974.7)	1,800		FSP4110WM	1.5	(0.7)
	46%	(1175.0)	44	(1117.0)	2,000		FSP4610WM	1.7	(0.8)

Applications: Process Water, Ethylene Glycol (50%)

40 W/in ² 304 SS (6.2 W/cm ²)	8%	(222.0)	6%	(165.0)	600	FSP91WK		0.4	(0.2)
	10%	(260.0)	7%	(203.0)	750	FSP101WK		0.4	(0.2)
	12%	(311.0)	10	(254.0)	900	FSP121WK	FSP1210WK	0.5	(0.3)
	13%	(343.0)	11%	(286.0)	1,000	FSP131WK	FSP1310WK	0.5	(0.3)
	16%	(413.0)	13%	(352.4)	1,300	FSP161WK	FSP1610WK	0.6	(0.3)
	17%	(451.0)	15%	(393.0)	1,450	FSP181WK	FSP1810WK	0.7	(0.4)
	19%	(489.0)	17	(431.0)	1,600		FSP1910WK	0.7	(0.4)
	22	(558.0)	19%	(502.0)	1,800		FSP2210WK	0.8	(0.4)
	23%	(603.0)	21%	(546.0)	2,000		FSP2410WK	0.9	(0.4)
	25	(635.0)	22%	(578.0)	2,100		FSP2510WK	0.9	(0.4)
	28%	(727.1)	26%	(669.9)	2,500		FSP2910WK	1.1	(0.5)
	31%	(803.2)	29%	(746.1)	2,700		FSP3210WK	1.2	(0.6)
	34%	(866.8)	31%	(809.6)	3,000		FSP3410WK	1.3	(0.6)
	36%	(936.6)	34%	(879.5)	3,200		FSP3710WK	1.4	(0.7)
	40%	(1031.9)	38%	(974.7)	3,600		FSP4110WK	1.5	(0.7)
	46%	(1175.0)	44	(1117.0)	4,000		FSP4610WK	1.7	(0.8)

RAPID SHIP

- Available on all elements unless otherwise noted
- Same day shipment up to 15 pieces

Tubular Heaters

FIREBAR Single/Double-Ended Heaters

5/8-Inch Single-Ended FIREBAR

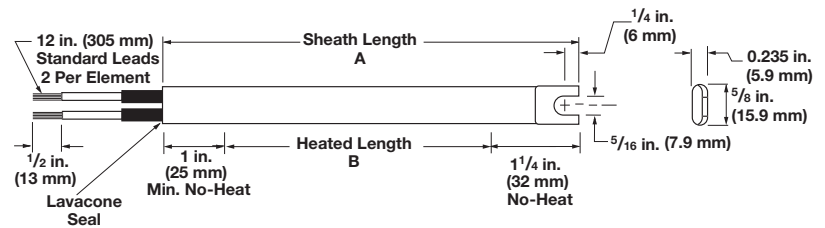

FIREBAR Description	Sheath A Dimension		Heated B Dimension		Watts	Code Number		Est. Net Weight	
	in.	(mm)	in.	(mm)		120VAC	240VAC	lbs	(kg)

Applications: Radiant, Platens, Dies, Low-Temperature Ovens 300°F (150°C)

20 W/in ²	11 1/2	(292)	8	(203)	250	FSA121WM		0.3	(0.2)
Incoloy®	15 1/2	(394)	12	(304)	375	FSA161WM	FSA1610WM	0.4	(0.2)
(3.1 W/cm ²)	19 1/2	(495)	16	(406)	500	FSA201WM	FSA2010WM	0.5	(0.3)
	28	(711)	24	(609)	750	FSA281WM	FSA2810WM	0.6	(0.3)
	36	(914)	32	(812)	1,000	FSA361WM	FSA3610WM	0.8	(0.4)
	52	(1321)	48	(1219)	1,500	FSA521WM	FSA5210WM	1.2	(0.6)

RAPID SHIP

- Available on all elements unless otherwise noted
- Same day shipment up to 15 pieces