

ERBESSD INSTRUMENTS®

PHANTOM

Vibration Sensor

PHANTOM Expert Gen 3, the best wireless triaxial vibration and temperature sensor worldwide.



The triaxial vibration sensor is able to send **3 simultaneous** FFT and Time waveform recordings at once.

The signal from the Phantom sensors is encrypted, which ensures the reliability of the information and the security of your data.

TECHNICAL SPECIFICATIONS

There are two versions of the **Phantom Expert Gen 3** depending on your needs based on machine specifications.

High Range (EPH-V11E)



Frequency Range:

0.5 Hz - 10 kHz [x,y]
0.5 Hz - 5.1 kHz [z]

Dynamic Range:

±8 / ±16 / ±32 g

Data Receiving Interval:

(Configurable)
Min: 10 min
Max: 1440 min

Sensitivity:

100 mV/G

High Sensitivity (EPH-V10E)



Frequency Range:

0.5 Hz - 4 kHz [x,y]
0.5 Hz - 1.8 kHz [z]

Dynamic Range:

±2 / ±4 / ±8 g

Data Receiving Interval:

(Configurable)
Min: 10 min
Max: 1440 min

Sensitivity:

100 mV/G

HIGH RANGE TECHNICAL SPECIFICATIONS



MEASUREMENT					
Product code	EPH-V11E				
Built-in sensor	MEMS Sensor				
Sensing resolution (X, Y, Z)	240 µg				
Nominal frequency range (@ 25,600)	0.5 Hz to 10 kHz (X,Y), 0.5 Hz to 5.1 kHz (Z)				
Dynamic range (configurable)	±8 /±16 /±32 g				
Recording time (s) 3 axes	1	2	4	8	16
Recording time (s) 1 axes	3	6	12	24	48
Nominal Sample rate (Hz)	25,600	12,800	6,400	3,200	1,600
Max frequency (Hz) [x,y]	10,000	5,000	2,500	1,250	625
Max frequency (Hz) [z]	5,100	5,000	2,500	1,250	625
Resolution lines	6,400				
Spectral noise (10 Hz)	630 µg/√Hz				
CONNECTIVITY AND SOFTWARE					
Wireless protocol	Bluetooth BLE 5.0				
Operating frequency	2.4 GHz				
Transmission power	±8 dBm				
Signal strength range	-90 dBm to -30 dBm				
Power output range	-4 dBm to +8 dBm (Configurable)				
Devices compatibility	iOS and Android devices (WISER VIBE PRO & Phantom™ Manager) and Phantom™ Gateway				
Software compatibility	DigivibeMX 11 M30 & Phantom™ Version / Phantom™ Manager and WiSER VIBE PRO				
Operating distance	100 m Line sight*				
DIMENSIONS AND FIXTURE					
Dimensions (h x w)	47 x 33 mm				
Protection grade	IP69				
Weight	185 grams				
Fixture	Fastener 1/4-28 UNF				
Housing material	ABS, stainless steel				
ENVIRONMENTAL CONDITIONS					
Operating temperature	-40 to 80 °C (40 to 176 °F)				

*Ideal environment. No competing signals or obstructions.

HIGH SENSITIVITY TECHNICAL SPECIFICATIONS



MEASUREMENT					
Product code	EPH-V10E				
Built-in sensor	MEMS Sensor				
Sensing resolution (X, Y, Z)	60 µg				
Nominal Frequency range (@ 25,600)	0.5 Hz to 4 kHz (X,Y), 0.5 Hz to 1.8 kHz (Z)				
Dynamic range (configurable)	±2 /±4 /±8 g				
Recording time (s) 3 axes	1	2	4	8	16
Recording time (s) 1 axes	3	6	12	24	48
Nominal Sample rate (Hz)	25,600	12,800	6,400	3,200	1,600
Max frequency (Hz) [x,y]	4,000	4,000	2,500	1,250	625
Max frequency (Hz) [z]	1,800	1,800	1,800	1,250	625
Resolution lines	6,400				
Spectral noise (10 Hz)	130 µg√Hz				
CONNECTIVITY AND SOFTWARE					
Wireless protocol	Bluetooth BLE 5.0				
Operating frequency	2.4 GHz				
Transmission power	±8 dBm				
Signal strength range	-90 dBm to -30 dBm				
Power output range	-4 dBm to +8 dBm (Configurable)				
Device compatibility	iOS and Android devices (WISER VIBE PRO & Phantom™ Manager) and Phantom™ Gateway				
Software compatibility	DigivibeMX 11 M30 & Phantom™ Version / Phantom™ Manager and WISER VIBE PRO				
Operating distance	100 m Line sight*				
DIMENSIONS AND FIXTURE					
Dimensions (h x w)	47 x 33 mm				
Protection grade	IP69				
Weight	185 grams				
Fixture	Fastener 1/4-28 UNF				
Housing material	ABS, stainless steel				
ENVIRONMENTAL CONDITIONS					
Operating temperature	-40 to 80 °C (40 to 176 °F)				

*Ideal environment. No competing signals or obstructions.

BATTERY INFORMATION

POWER SUPPLY	
Battery type	Lithium battery (CR2477)
Battery life	65,000 measurements (duration depends on user configuration)*
	Standby mode if Gateway not detected
	Consumption of 6-9 μA in Standby mode

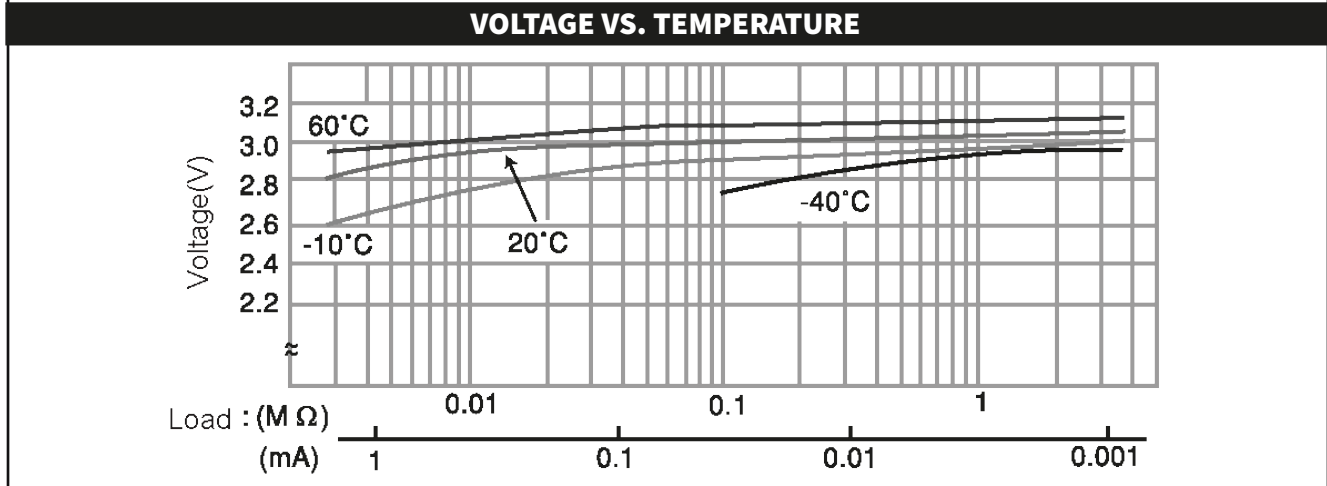
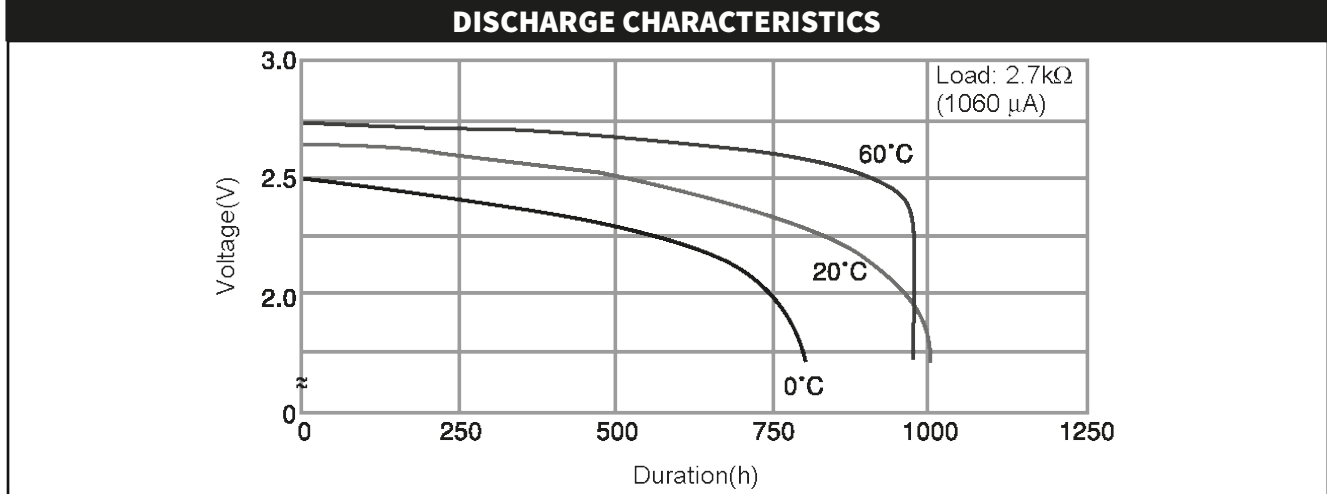

*Battery life is directly affected by temperature, frequency of alarms, and other factors independent of user settings.

DIMENSIONS



FRONT VIEW

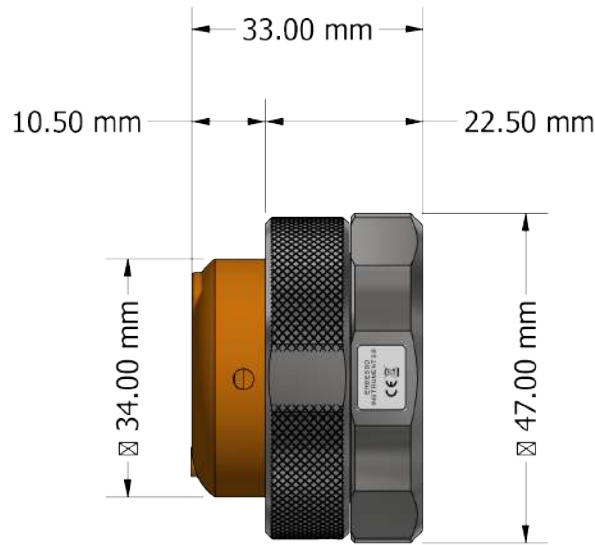

SIDE VIEW



REAR VIEW

QUICK GUIDE

Easily Orient your Dominant Axis with tactile iconography, and a user adjustable base.

Visually use the symbol on the top of the Phantom to locate the axis in the right position.



Once you've placed the sensor on your machine, set it up on DigivibeMX and define each axis to an orientation: Horizontal, Vertical and Axial.

Phantom Expert Gen3 Summary

The Phantom vibration sensor has everything you need to start collecting data without the need of additional accessories.

Add it to your measurement point through DigivibeMX and you will be ready to monitor your machines instantly.

Use Machine Learning, Envelope Alarms, Identify Bearing Faults and more with DigivibeMX.

CERTIFICATIONS

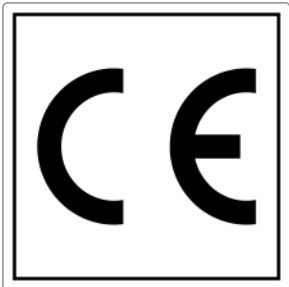

Analyze and visualize the health of your machines with:

DigivibeMX®

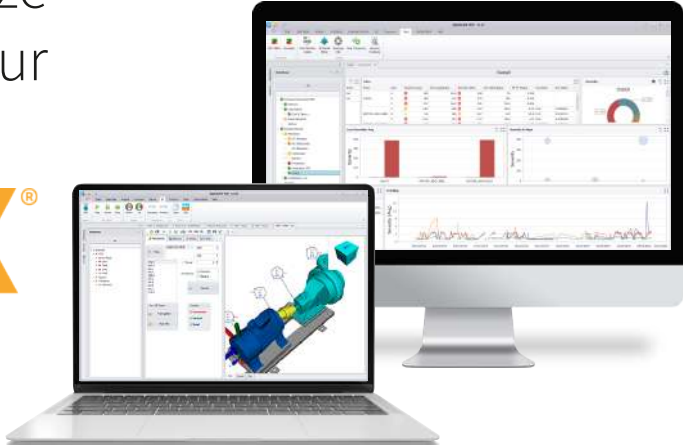

Easily access your data worldwide with EI-Analytic and WiSER Vibe Pro.

Phantom sensors are compatible with communication protocol (using Gateway Gen 2)



MEET THE PHANTOM FAMILY

Phantom RPM

With the RPM sensor you can easily analyze the revolutions per minute of any rotating assembly with incredible precision with a switching speed of 600kRPM.



Phantom Thermocouple & Phantom Infrared

Have better control of your machines' temperature. You can connect up to 3 thermocouple sensors or acquire the infrared temperature sensor so you can monitor with extreme precision.



Phantom Current

The Phantom current module allows you to measure up to 4 amperage channels with clamps from 50amp to 500amp



Phantom GP

General Purpose modules that are compatible with any kind of sensor to obtain wireless data. Available for 4-20mA, 0-10V, Digital Signals and 2.2Vpp sensors.



Phantom All in One

Obtain the reliability of three sensors in one Phantom module; vibration, temperature and current. Complete condition monitoring all in one.



Phantom Thermographic Camera

With the Phantom thermal camera you can take infrared images of surfaces or objects at a distance of no more than 1m. Use DigivibeMX to create trends and monitor delta T.



ERBESSD INSTRUMENTS®

WORLDWIDE toll-free:

+1-877-223-4606

ENGLISH:

Sales, Service & Support Engineer

+1-518-874-2700

info@erbessdreliability.com

SPANISH & FRENCH:

Sales, Service & Support Engineer

+52 (55) 6280-7654

info@erbessd-instruments.com

BUY ONLINE

www.erbessd-instruments.com

ALL THE IMAGES ARE FOR ILLUSTRATIVE PURPOSES ONLY. THE FINAL PRODUCT MAY VARY DEPENDING ON THE VERSION AND/OR THE CHANGES OR UPGRADES MADE TO THE PARTS AND COMPONENTS OF THE DEVICES

© 2022 ERBESSD INSTRUMENTS

P3-DS2022.1014.01