

Operating Instructions

Dosimag

Electromagnetic flowmeter

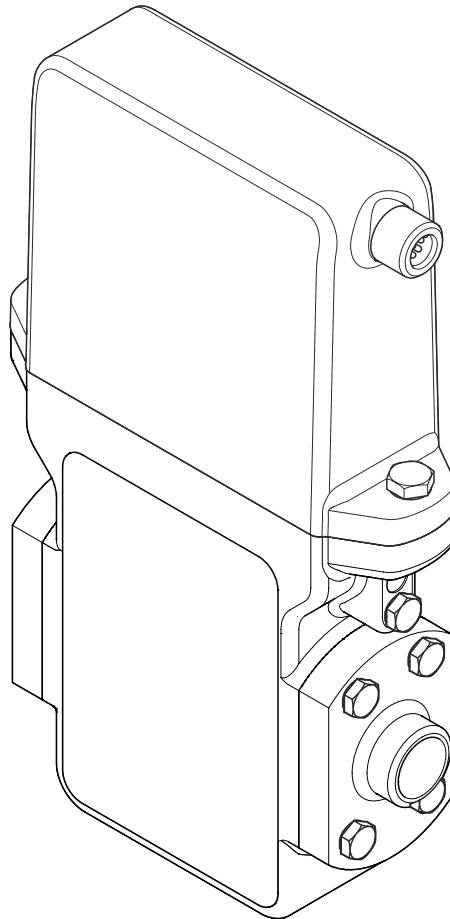

- Make sure the document is stored in a safe place such that it is always available when working on or with the device.
- To avoid danger to individuals or the facility, read the "Basic safety instructions" section carefully, as well as all other safety instructions in the document that are specific to working procedures.
- The manufacturer reserves the right to modify technical data without prior notice. Your Endress+Hauser Sales Center will supply you with current information and updates to these instructions.

Table of contents

1	Document information	5		
1.1	Document function	5		
1.2	Symbols used	5		
1.2.1	Safety symbols	5		
1.2.2	Electrical symbols	5		
1.2.3	Symbols for certain types of information	5		
1.2.4	Symbols in graphics	6		
1.3	Documentation	6		
1.3.1	Standard documentation	7		
1.3.2	Supplementary device-dependent documentation	7		
1.4	Registered trademarks	7		
2	Basic safety instructions	8		
2.1	Requirements for the personnel	8		
2.2	Designated use	8		
2.3	Workplace safety	9		
2.4	Operational safety	9		
2.5	Product safety	9		
2.6	IT security	9		
3	Product description	11		
3.1	Product design	11		
4	Incoming acceptance and product identification	12		
4.1	Incoming acceptance	12		
4.2	Product identification	12		
4.2.1	Sensor nameplate	13		
4.2.2	Symbols on measuring device	14		
5	Storage and transport	15		
5.1	Storage conditions	15		
5.2	Transporting the product	15		
5.3	Packaging disposal	15		
6	Installation	16		
6.1	Installation conditions	16		
6.1.1	Mounting position	16		
6.1.2	Requirements from environment and process	19		
6.1.3	Special mounting instructions	20		
6.2	Mounting the measuring device	21		
6.2.1	Required tools	21		
6.2.2	Preparing the measuring device	21		
6.2.3	Mounting the measuring device	22		
6.2.4	Welding the sensor into the pipe (welding connections)	22		
6.2.5	Cleaning with pigs	22		
6.2.6	Seals	23		
			6.2.7	Nominal diameter and flow
			6.3	Post-installation check
			7	Electrical connection
			7.1	Connection conditions
			7.1.1	Requirements for connecting cable
			7.1.2	Terminal assignment
			7.1.3	Pin assignment, device plug
			7.1.4	Requirements for the supply unit
			7.2	Connecting the measuring device
			7.2.1	Connecting the transmitter
			7.3	Ensuring the degree of protection
			7.4	Post-connection check
			8	Operation options
			8.1	Overview of operation options
			8.2	Access to the operating menu via the operating tool
			8.2.1	Connecting the operating tool
			8.2.2	FieldCare
			8.2.3	DeviceCare
			9	System integration
			9.1	Overview of device description files
			9.1.1	Current version data for the device
			9.1.2	Operating tools
			10	Commissioning
			10.1	Function check
			10.2	Switching on the measuring device
			10.3	Establishing a connection via FieldCare
			10.4	Configuring the measuring device
			10.4.1	Defining the tag name
			10.4.2	Setting the system units
			10.4.3	Configuring the pulse/frequency/switch output
			10.4.4	Low flow cut off
			10.5	Advanced settings
			10.5.1	Sensor adjustment
			10.5.2	Configuring the totalizer
			10.6	Simulation
			11	Operation
			11.1	Reading device locking status
			11.2	Reading access authorization status on operating software
			11.3	Reading measured values
			11.3.1	Process variables
			11.3.2	Totalizer
			11.3.3	Output values
			11.4	Performing a totalizer reset

12	Diagnostics and troubleshooting ...	46	Index	71
12.1	General troubleshooting	46		
12.2	Diagnostic information in FieldCare	46		
12.2.1	Diagnostic options	46		
12.2.2	Calling up remedy information	47		
12.3	Adapting the diagnostic information	47		
12.3.1	Adapting the diagnostic behavior	47		
12.4	Overview of diagnostic information	47		
12.5	Pending diagnostic events	49		
12.6	Diagnostic list	50		
12.7	Event logbook	50		
12.7.1	Event history	50		
12.7.2	Filtering the event logbook	50		
12.7.3	Overview of information events	50		
12.8	Resetting the measuring device	50		
12.9	Device information	51		
12.10	Firmware history	52		
13	Maintenance	54		
13.1	Maintenance tasks	54		
13.1.1	Exterior cleaning	54		
13.1.2	Interior cleaning	54		
13.1.3	Replacing seals	54		
13.2	Measuring and test equipment	54		
13.3	Endress+Hauser services	54		
14	Repair	55		
14.1	General notes	55		
14.2	Spare parts	55		
14.3	Endress+Hauser services	55		
14.4	Return	55		
14.5	Disposal	55		
14.5.1	Removing the measuring device	55		
14.5.2	Disposing of the measuring device ...	56		
15	Accessories	57		
15.1	Device-specific accessories	57		
15.1.1	For the sensor	57		
15.2	Communication-specific accessories	57		
15.3	Service-specific accessories	58		
16	Technical data	59		
16.1	Application	59		
16.2	Function and system design	59		
16.3	Input	59		
16.4	Output	60		
16.5	Power supply	61		
16.6	Performance characteristics	62		
16.7	Installation	63		
16.8	Environment	63		
16.9	Process	64		
16.10	Mechanical construction	65		
16.11	Operability	67		
16.12	Certificates and approvals	68		
16.13	Accessories	69		
16.14	Supplementary documentation	69		





1 Document information

1.1 Document function







These Operating Instructions contain all the information that is required in various phases of the life cycle of the device: from product identification, incoming acceptance and storage, to mounting, connection, operation and commissioning through to troubleshooting, maintenance and disposal.

1.2 Symbols used



1.2.1 Safety symbols









Symbol	Meaning
	DANGER! This symbol alerts you to a dangerous situation. Failure to avoid this situation will result in serious or fatal injury.
	WARNING! This symbol alerts you to a dangerous situation. Failure to avoid this situation can result in serious or fatal injury.
	CAUTION! This symbol alerts you to a dangerous situation. Failure to avoid this situation can result in minor or medium injury.
	NOTE! This symbol contains information on procedures and other facts which do not result in personal injury.

1.2.2 Electrical symbols



Symbol	Meaning
	Direct current
	Alternating current
	Direct current and alternating current
	Ground connection A grounded terminal which, as far as the operator is concerned, is grounded via a grounding system.
	Protective ground connection A terminal which must be connected to ground prior to establishing any other connections.
	Equipotential connection A connection that has to be connected to the plant grounding system: This may be a potential equalization line or a star grounding system depending on national or company codes of practice.

1.2.3 Symbols for certain types of information

Symbol	Meaning
	Permitted Procedures, processes or actions that are permitted.
	Preferred Procedures, processes or actions that are preferred.

Symbol	Meaning
	Forbidden Procedures, processes or actions that are forbidden.
	Tip Indicates additional information.
	Reference to documentation
	Reference to page
	Reference to graphic
	Notice or individual step to be observed
1, 2, 3...	Series of steps
	Result of a step
	Help in the event of a problem
	Visual inspection

1.2.4 Symbols in graphics

Symbol	Meaning
1, 2, 3,...	Item numbers
1, 2, 3...	Series of steps
A, B, C, ...	Views
A-A, B-B, C-C, ...	Sections
	Hazardous area
	Safe area (non-hazardous area)
	Flow direction

1.3 Documentation

 For an overview of the scope of the associated Technical Documentation, refer to the following:

- The *W@M Device Viewer* : Enter the serial number from the nameplate (www.endress.com/deviceviewer)
- The *Endress+Hauser Operations App*: Enter the serial number from the nameplate or scan the 2-D matrix code (QR code) on the nameplate.

 For a detailed list of the individual documents along with the documentation code

1.3.1 Standard documentation

Document type	Purpose and content of the document
Technical Information	<p>Planning aid for your device The document contains all the technical data on the device and provides an overview of the accessories and other products that can be ordered for the device.</p>
Sensor Brief Operating Instructions	<p>Guides you quickly to the 1st measured value - Part 1 The Sensor Brief Operating Instructions are aimed at specialists with responsibility for installing the measuring device.</p> <ul style="list-style-type: none"> ▪ Incoming acceptance and product identification ▪ Storage and transport ▪ Installation
Transmitter Brief Operating Instructions	<p>Guides you quickly to the 1st measured value - Part 2 The Transmitter Brief Operating Instructions are aimed at specialists with responsibility for commissioning, configuring and parameterizing the measuring device (until the first measured value).</p> <ul style="list-style-type: none"> ▪ Product description ▪ Installation ▪ Electrical connection ▪ Operation options ▪ System integration ▪ Commissioning ▪ Diagnostic information
Description of Device Parameters	<p>Reference for your parameters The document provides a detailed explanation of each individual parameter in the Expert operating menu. The description is aimed at those who work with the device over the entire life cycle and perform specific configurations.</p>

1.3.2 Supplementary device-dependent documentation

Additional documents are supplied depending on the device version ordered: Always comply strictly with the instructions in the supplementary documentation. The supplementary documentation is an integral part of the device documentation.

1.4 Registered trademarks

TRI-CLAMP®

Registered trademark of Ladish & Co., Inc., Kenosha, USA

Applicator®, FieldCare®, DeviceCare®

Registered or registration-pending trademarks of the Endress+Hauser Group

2 Basic safety instructions

2.1 Requirements for the personnel

The personnel for installation, commissioning, diagnostics and maintenance must fulfill the following requirements:

- ▶ Trained, qualified specialists must have a relevant qualification for this specific function and task
- ▶ Are authorized by the plant owner/operator
- ▶ Are familiar with federal/national regulations
- ▶ Before beginning work, the specialist staff must have read and understood the instructions in the Operating Instructions and supplementary documentation as well as in the certificates (depending on the application)
- ▶ Following instructions and basic conditions

The operating personnel must fulfill the following requirements:

- ▶ Being instructed and authorized according to the requirements of the task by the facility's owner-operator
- ▶ Following the instructions in these Operating Instructions

2.2 Designated use

Application and media

Depending on the version ordered, the measuring device can also measure potentially explosive, flammable, poisonous and oxidizing media.

Measuring devices for use in hazardous areas, in hygienic applications or in applications where there is an increased risk due to process pressure, are labeled accordingly on the nameplate.

To ensure that the measuring device remains in proper condition for the operation time:

- ▶ Only use the measuring device in full compliance with the data on the nameplate and the general conditions listed in the Operating Instructions and supplementary documentation.
- ▶ Check the nameplate to verify if the device ordered can be put to its intended use in the approval-related area (e.g. explosion protection, pressure vessel safety).
- ▶ Use the measuring device only for media against which the process-wetted materials are adequately resistant.
- ▶ If the measuring device is not operated at atmospheric temperature, compliance with the relevant basic conditions specified in the associated device documentation is absolutely essential: "Documentation" section →  6.
- ▶ Protect the measuring device permanently against corrosion from environmental influences.

Incorrect use

Non-designated use can compromise safety. The manufacturer is not liable for damage caused by improper or non-designated use.

WARNING

Danger of breakage of the sensor due to corrosive or abrasive fluids or from environmental conditions!

- ▶ Verify the compatibility of the process fluid with the sensor material.
- ▶ Ensure the resistance of all fluid-wetted materials in the process.
- ▶ Keep within the specified pressure and temperature range.

Verification for borderline cases:

- ▶ For special fluids and fluids for cleaning, Endress+Hauser is glad to provide assistance in verifying the corrosion resistance of fluid-wetted materials, but does not accept any

warranty or liability as minute changes in the temperature, concentration or level of contamination in the process can alter the corrosion resistance properties.

Residual risks

The external surface temperature of the housing can increase by max. 10 K due to the power consumption of the electronic components. Hot process fluids passing through the measuring device will further increase the surface temperature of the housing. The surface of the sensor, in particular, can reach temperatures which are close to the fluid temperature.

Possible burn hazard due to fluid temperatures!

- ▶ For elevated fluid temperature, ensure protection against contact to prevent burns.

2.3 Workplace safety

For work on and with the device:

- ▶ Wear the required personal protective equipment according to federal/national regulations.

For welding work on the piping:

- ▶ Do not ground the welding unit via the measuring device.

If working on and with the device with wet hands:

- ▶ It is recommended to wear gloves on account of the higher risk of electric shock.

2.4 Operational safety

Risk of injury.

- ▶ Operate the device in proper technical condition and fail-safe condition only.
- ▶ The operator is responsible for interference-free operation of the device.

Conversions to the device

Unauthorized modifications to the device are not permitted and can lead to unforeseeable dangers.

- ▶ If, despite this, modifications are required, consult with Endress+Hauser.

Repair

To ensure continued operational safety and reliability,

- ▶ Carry out repairs on the device only if they are expressly permitted.
- ▶ Observe federal/national regulations pertaining to repair of an electrical device.
- ▶ Use original spare parts and accessories from Endress+Hauser only.

2.5 Product safety

This measuring device is designed in accordance with good engineering practice to meet state-of-the-art safety requirements, has been tested, and left the factory in a condition in which it is safe to operate.

It meets general safety standards and legal requirements. It also complies with the EC directives listed in the device-specific EC Declaration of Conformity. Endress+Hauser confirms this by affixing the CE mark to the device.

2.6 IT security

We only provide a warranty if the device is installed and used as described in the Operating Instructions. The device is equipped with security mechanisms to protect it against any inadvertent changes to the device settings.

IT security measures in line with operators' security standards and designed to provide additional protection for the device and device data transfer must be implemented by the operators themselves.

3 Product description

The device consists of a transmitter and a sensor.

The device is available as a compact version:

The transmitter and sensor form a mechanical unit.

3.1 Product design

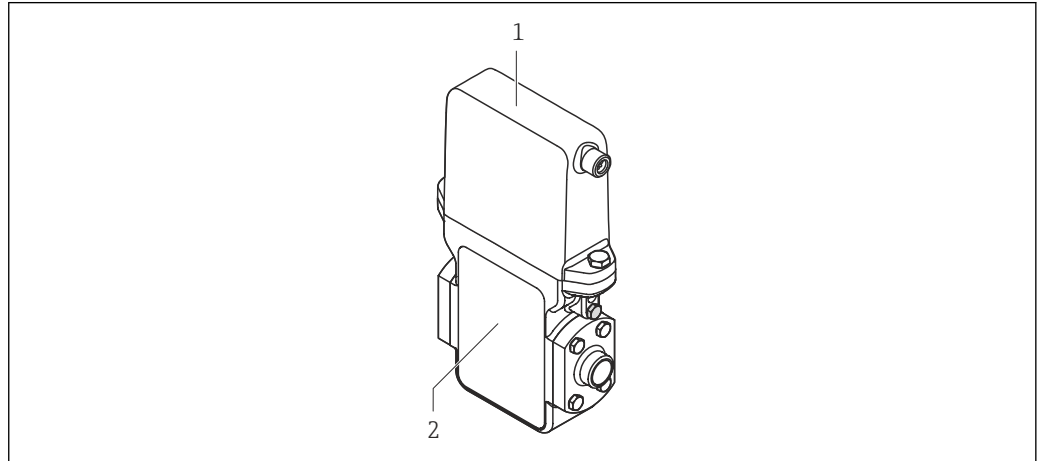

A0026624

1 Important components of the measuring device

1 Transmitter

2 Sensor

4 Incoming acceptance and product identification

4.1 Incoming acceptance



A0028673

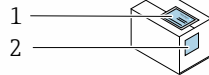

Are the order codes on the delivery note (1) and the product sticker (2) identical?

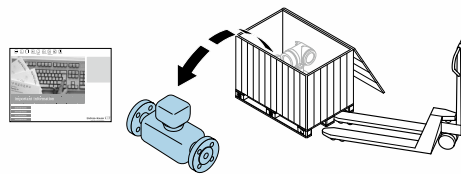

A0028673

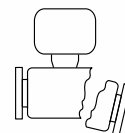
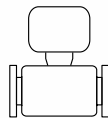

Are the goods undamaged?



A0028673

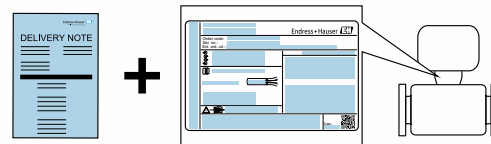



Do the nameplate data match the ordering information on the delivery note?

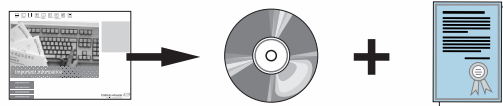

A0028673



Is the CD-ROM with the Technical Documentation (depends on device version) and documents present?



-  If one of the conditions is not satisfied, contact your Endress+Hauser Sales Center.
- Depending on the device version, the CD-ROM might not be part of the delivery! The Technical Documentation is available via the Internet or via the *Endress+Hauser Operations App*, see the "Product identification" section →  13.

4.2 Product identification

The following options are available for identification of the measuring device:

- Nameplate specifications
- Order code with breakdown of the device features on the delivery note
- Enter serial numbers from nameplates in *W@M Device Viewer* (www.endress.com/deviceviewer): All information about the measuring device is displayed.
- Enter the serial number from the nameplates into the *Endress+Hauser Operations App* or scan the 2-D matrix code (QR code) on the nameplate with the *Endress+Hauser Operations App*: all the information for the measuring device is displayed.

For an overview of the scope of the associated Technical Documentation, refer to the following:

- The chapters "Additional standard documentation on the device" →  7 and "Supplementary device-dependent documentation" →  7
- The *W@M Device Viewer*: Enter the serial number from the nameplate (www.endress.com/deviceviewer)
- The *Endress+Hauser Operations App*: Enter the serial number from the nameplate or scan the 2-D matrix code (QR code) on the nameplate.

4.2.1 Sensor nameplate

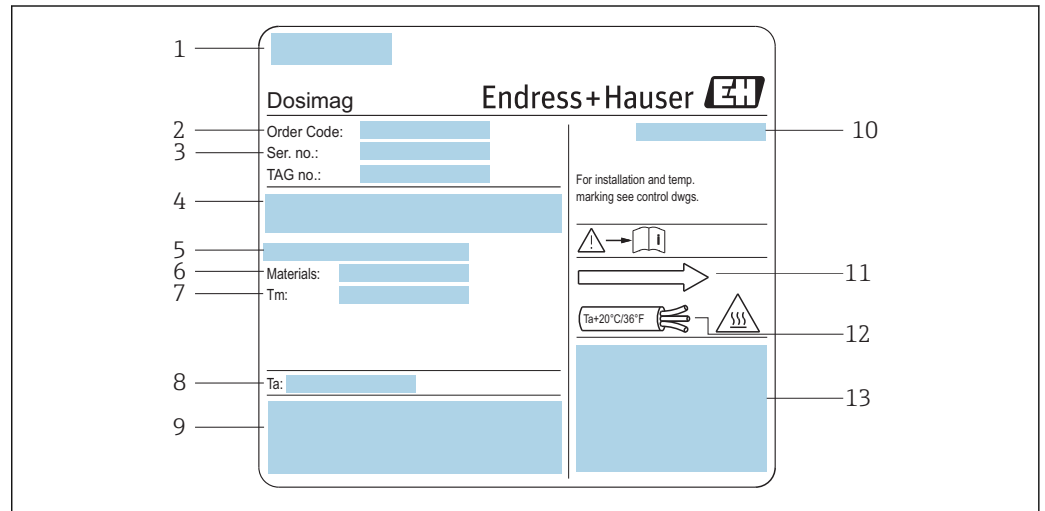

 2 Example of sensor nameplate

- 1 Manufacturing location
- 2 Order code: see the specifications on the order confirmation for the meanings of the individual letters and digits
- 3 Serial number
- 4 Supply voltage and power consumption
- 5 Process connection
- 6 Wetted materials
- 7 Maximum process temperature
- 8 Permitted ambient temperature range
- 9 Space reserved for additional information on the device version (approvals, certificates, etc.)
- 10 Degree of protection
- 11 Flow direction
- 12 Cable temperature
- 13 Space reserved for additional information on the device version (approvals, certificates, etc.)



Order code

The measuring device is reordered using the order code.

Extended order code

- The device type (product root) and basic specifications (mandatory features) are always listed.
- Of the optional specifications (optional features), only the safety and approval-related specifications are listed (e.g. LA). If other optional specifications are also ordered, these are indicated collectively using the # placeholder symbol (e.g. #LA#).
- If the ordered optional specifications do not include any safety and approval-related specifications, they are indicated by the + placeholder symbol (e.g. XXXXXX-ABCDE+).

4.2.2 Symbols on measuring device

Symbol	Meaning
	WARNING! This symbol alerts you to a dangerous situation. Failure to avoid this situation can result in serious or fatal injury.
	Reference to documentation Refers to the corresponding device documentation.
	Protective ground connection A terminal which must be connected to ground prior to establishing any other connections.

5 Storage and transport

5.1 Storage conditions

Observe the following notes for storage:

- Store in the original packaging to ensure protection from shock.
- Do not remove protective covers or protective caps installed on process connections. They prevent mechanical damage to the sealing surfaces and contamination in the measuring tube.
- Protect from direct sunlight to avoid unacceptably high surface temperatures.
- Select a storage location where moisture cannot collect in the measuring device as fungus and bacteria infestation can damage the lining.
- Store in a dry and dust-free place.
- Do not store outdoors.

Storage temperature →  63

5.2 Transporting the product

Transport the measuring device to the measuring point in the original packaging.

-  Do not remove protective covers or caps installed on process connections. They prevent mechanical damage to the sealing surfaces and contamination in the measuring tube.

5.3 Packaging disposal

All packaging materials are environmentally friendly and 100% recyclable:

- Measuring device secondary packaging: polymer stretch film that conforms to EC Directive 2002/95/EC (RoHS).
- Packaging:
 - Wood crate, treated in accordance with ISPM 15 standard, which is confirmed by the affixed IPPC logo.
 - or
 - Carton in accordance with European Packaging Directive 94/62EC; recyclability is confirmed by the affixed RESY symbol.
- Seaworthy packaging (optional): Wood crate, treated in accordance with ISPM 15 standard, which is confirmed by the affixed IPPC logo.
- Carrying and mounting hardware:
 - Disposable plastic pallet
 - Plastic straps
 - Plastic adhesive strips
- Dunnage: Paper cushion

6 Installation

6.1 Installation conditions

6.1.1 Mounting position

Mounting location

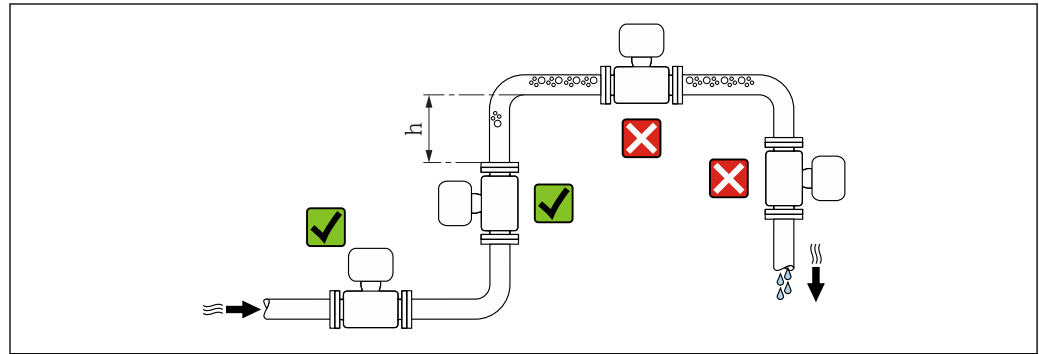

A0029343

Preferably install the sensor in an ascending pipe, and ensure a sufficient distance to the next pipe elbow: $h \geq 2 \times DN$

Installation in down pipes

Install a siphon with a vent valve downstream of the sensor in down pipes whose length $h \geq 5 \text{ m}$ (16.4 ft). This precaution is to avoid low pressure and the consequent risk of damage to the measuring tube. This measure also prevents the system losing prime.

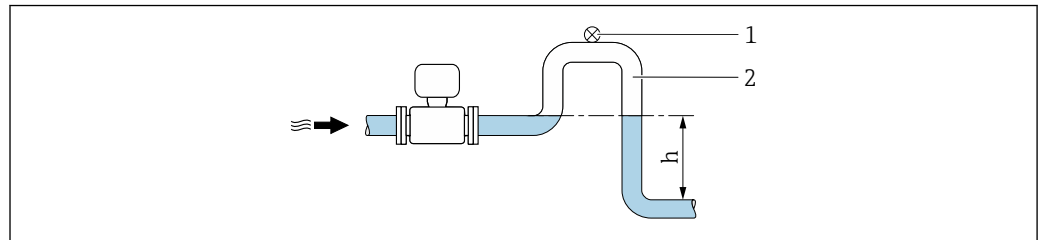

A0028981

3 Installation in a down pipe

- 1 Vent valve
- 2 Pipe siphon
- h Length of down pipe

Installation in partially filled pipes

A partially filled pipe with a gradient necessitates a drain-type configuration.

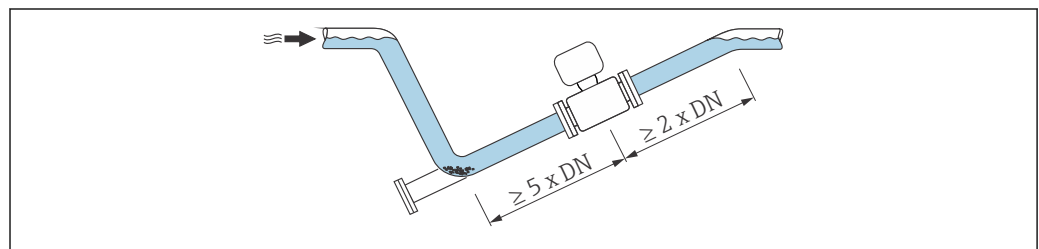

A0029257

Orientation

The direction of the arrow on the sensor nameplate helps you to install the sensor according to the flow direction (direction of medium flow through the piping).

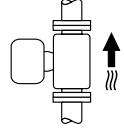
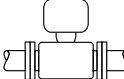
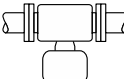
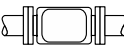
Orientation			Recommendation
A	Vertical orientation	 A0015591	☑☑
B	Horizontal orientation, transmitter at top	 A0015589	☑☑ ¹⁾
C	Horizontal orientation, transmitter at bottom	 A0015590	☑☑ ^{2) 3)}
D	Horizontal orientation, transmitter at side	 A0015592	☒

- 1) Applications with low process temperatures may decrease the ambient temperature. To maintain the minimum ambient temperature for the transmitter, this orientation is recommended.
- 2) Applications with high process temperatures may increase the ambient temperature. To maintain the maximum ambient temperature for the transmitter, this orientation is recommended.
- 3) To prevent the electronics module from overheating in the case of a sharp rise in temperature (e.g. CIP- or SIP processes), install the device with the transmitter component pointing downwards.

Horizontal

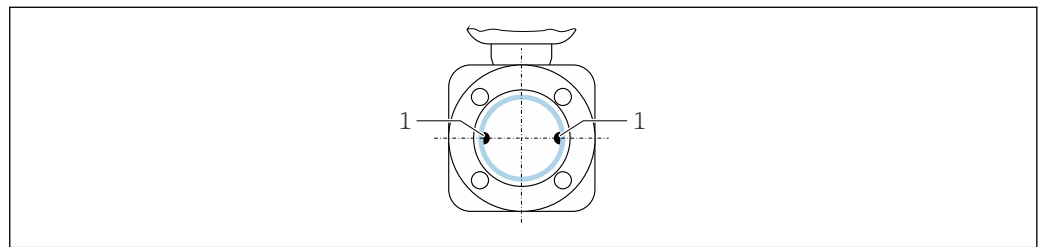

A0025B17

1 Measuring electrodes for signal detection

i Ideally, the measuring electrode plane should be horizontal. This prevents brief insulation of the two measuring electrodes by entrained air bubbles.

Valves

Never install the sensor downstream from a filling valve. If the sensor is completely empty this corrupts the measured value.

i Correct measurement is only possible if the pipe is completely full. Perform sample fillings before commencing filling in production.

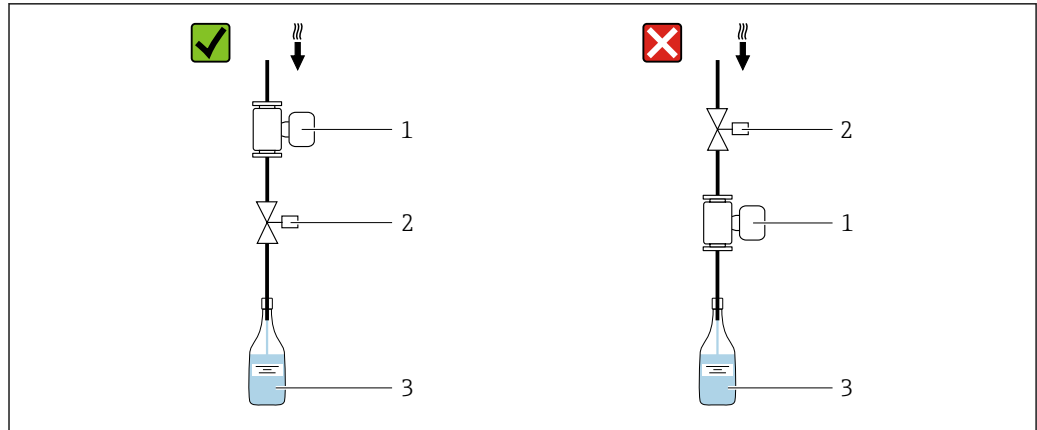

A0003768

- 1 Measuring device
- 2 Filling valve
- 3 Container

Filling systems

The pipe system must be completely full to ensure optimum measurement.

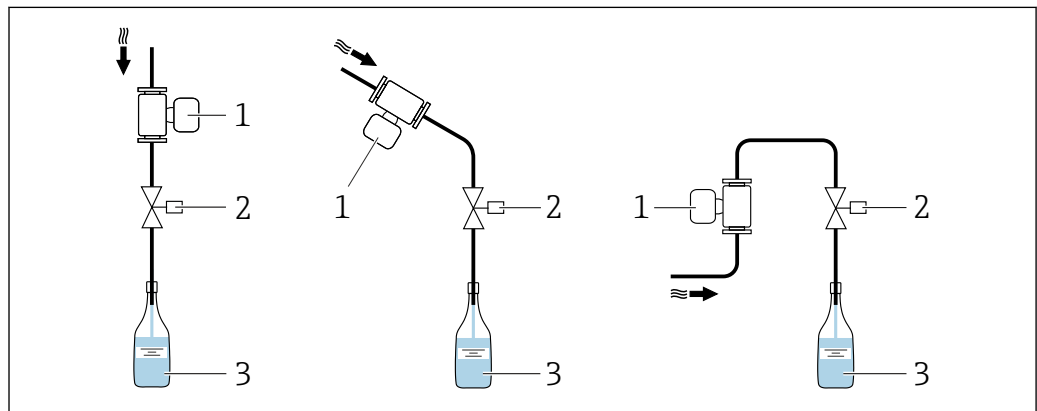

A0003795

- 4 Filling system
- 1 Measuring device
- 2 Filling valve
- 3 Container

Inlet and outlet runs

If possible, install the sensor upstream from fittings such as valves, T-pieces or elbows.

Observe the following inlet and outlet runs to comply with accuracy specifications:

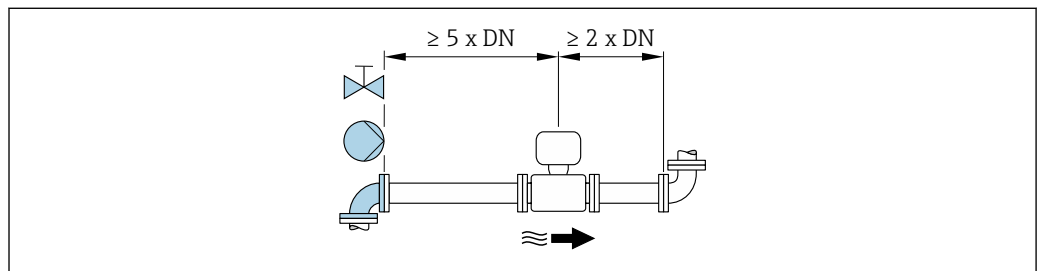

A0028997

Installation dimensions

 For the dimensions and installation lengths of the device, see the "Technical Information" document, "Mechanical construction" section.

6.1.2 Requirements from environment and process

Ambient temperature range

Transmitter	-40 to +60 °C (-40 to +140 °F)
Sensor	-40 to +60 °C (-40 to +140 °F)
Liner	Do not exceed or fall below the permitted temperature range of the liner →  64.

Temperature tables

 Observe the interdependencies between the permitted ambient and fluid temperatures when operating the device in hazardous areas.

 For detailed information on the temperature tables, see the separate document entitled "Safety Instructions" (XA) for the device.



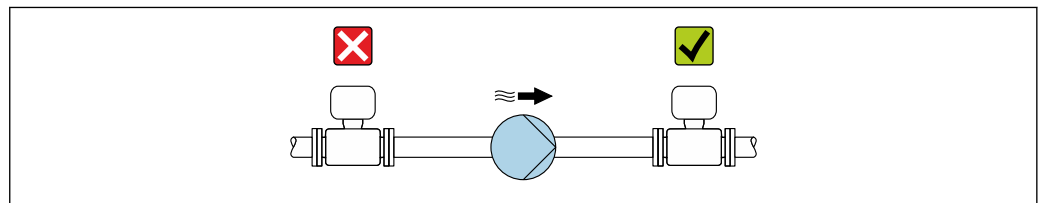

System pressure



A0028777

Never install the sensor on the pump suction side in order to avoid the risk of low pressure, and thus damage to the liner.

 Furthermore, install pulse dampers if reciprocating, diaphragm or peristaltic pumps are used.

-  ■ For information on the liner's resistance to partial vacuum →  65
- For information on the shock resistance of the measuring system →  64
- For information on the vibration resistance of the measuring system →  64

Vibrations

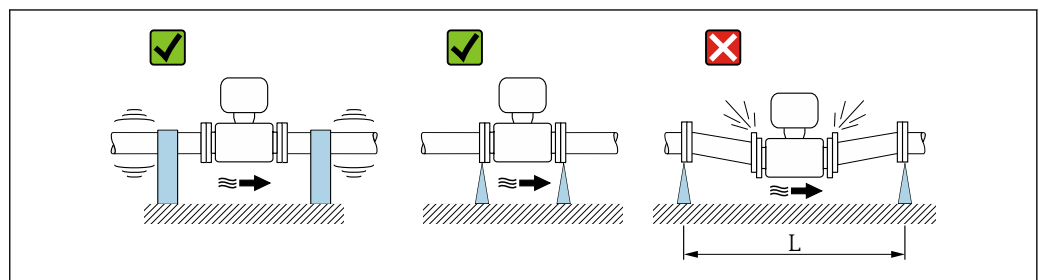

A0029004

 5 Measures to avoid device vibrations ($L > 10\text{ m}$ (33 ft))

In the event of very strong vibrations, the pipe and sensor must be supported and fixed.

- i** ■ For information on the shock resistance of the measuring system → 64
- For information on the vibration resistance of the measuring system → 64

Adapters

Suitable adapters to DIN EN 545 (double-flange reducers) can be used to install the sensor in larger-diameter pipes. The resultant increase in the rate of flow improves measuring accuracy with very slow-moving fluids. The nomogram shown here can be used to calculate the pressure loss caused by reducers and expanders.

i The nomogram only applies to liquids with a viscosity similar to that of water.

1. Calculate the ratio of the diameters d/D .
2. From the nomogram read off the pressure loss as a function of flow velocity (downstream from the reduction) and the d/D ratio.

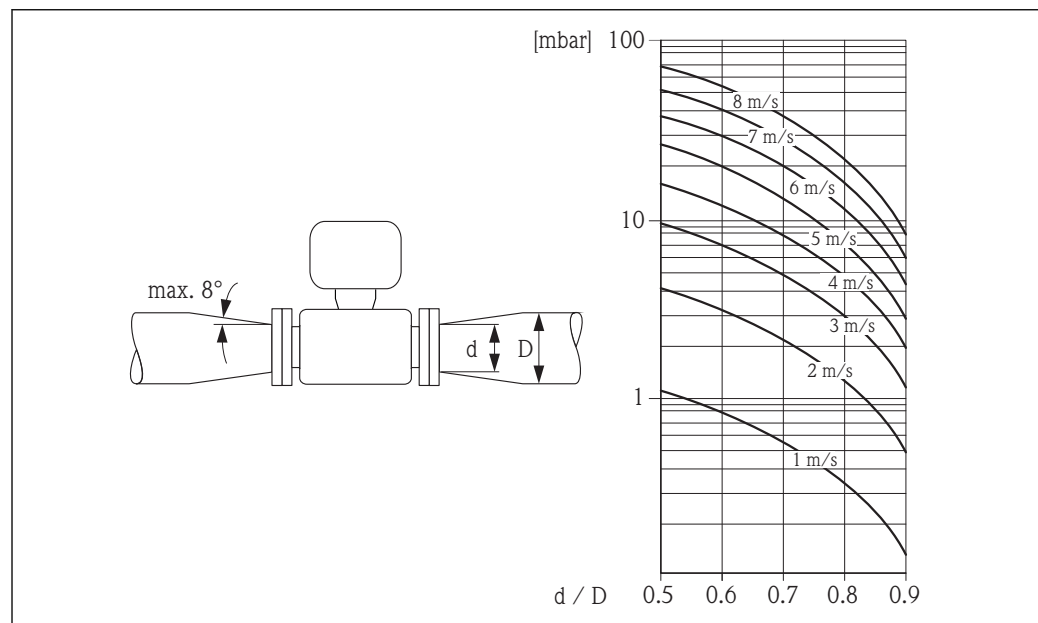

6.1.3 Special mounting instructions

Information for filling systems

Correct measurement is possible only if the piping is completely filled. We therefore recommend that some test batches be carried out prior to production batching.

Circular filling system

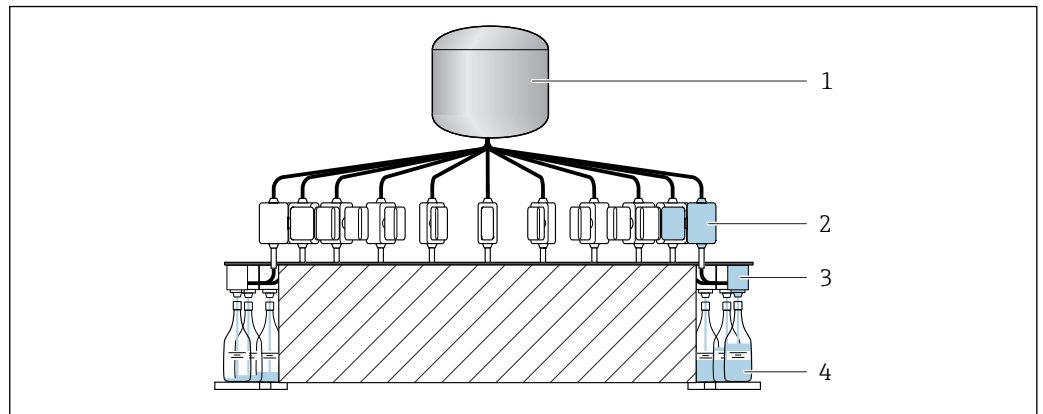

A0003761

- 1 Tank
- 2 Measuring device
- 3 Batching valve
- 4 Vessel

Linear filling system

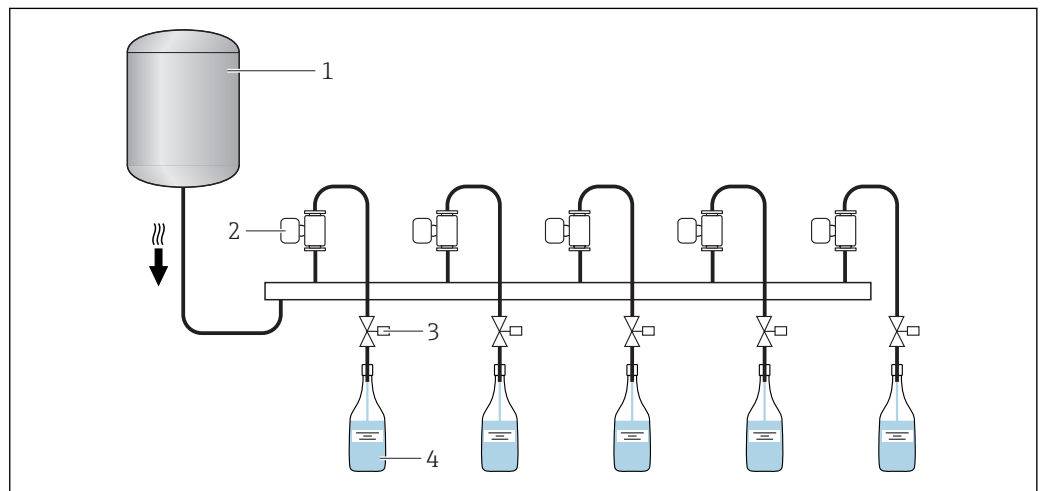

A0003762

- 1 Tank
- 2 Measuring device
- 3 Batching valve
- 4 Vessel

6.2 Mounting the measuring device

6.2.1 Required tools

For sensor

For flanges and other process connections:

- Screws, nuts, seals etc. are not included in the scope of supply and must be provided by the customer.
- Appropriate mounting tools

6.2.2 Preparing the measuring device

1. Remove all remaining transport packaging.

2. Remove any protective covers or protective caps present from the sensor.
3. Remove stick-on label on the electronics compartment cover.

6.2.3 Mounting the measuring device

WARNING

Danger due to improper process sealing!

- ▶ Ensure that the inside diameters of the gaskets are greater than or equal to that of the process connections and piping.
- ▶ Ensure that the gaskets are clean and undamaged.
- ▶ Install the gaskets correctly.

Depending on the order option, the measuring device is supplied with or without pre-installed process connections. Pre-installed process connections are secured to the measuring device using 4 hexagonal-headed bolts.



- ▶ Ensure that the direction of the arrow on the nameplate of the sensor matches the flow direction of the fluid.

 Depending on the application and pipe length, the measuring device may need to be supported or additionally secured.

6.2.4 Welding the sensor into the pipe (welding connections)

WARNING

Risk of destroying the electronics!

- ▶ Make sure that the welding system is not grounded via the sensor or transmitter.
1. Tack-weld the sensor to secure it in the pipe. A suitable welding jig can be ordered separately as an accessory →  69.
 2. Release the screws on the process connection flange and remove the sensor, along with the seal, from the pipe.
 3. Weld the process connection into the pipe.
 4. Reinstall the sensor in the pipe, and in doing so make sure that the seal is clean and in the right position.
-  ■ If thin-walled pipes carrying food are welded correctly, the seal is not damaged by the heat even when mounted. However, it is recommended to disassemble the sensor and seal.
- It must be possible to open the pipe by approx. 8 mm (0.31 in).

6.2.5 Cleaning with pigs

It is essential to take the internal diameters of the measuring tube and process connection into account when cleaning with pigs. All the dimensions and lengths of the sensor and transmitter are provided in the separate "Technical Information" document.



6.2.6 Seals

When mounting the process connections, make sure that the seals in question are dry, clean, undamaged and correctly centered.



-  The screws must be firmly tightened. The process connection forms a metal connection with the sensor, which ensures a defined compression of the seal.
- Depending on the application the seals should be replaced periodically, particularly if molded seals are used (aseptic version)!
The interval between changes depends on the frequency of the cleaning cycles, the cleaning temperature and the medium temperature.
Replacement seals can be ordered as an accessory.

6.2.7 Nominal diameter and flow

The diameter of the pipe and the flow rate determine the nominal diameter of the sensor. The optimum flow velocity is between 1 to 4 m/s (3.28 to 13.12 ft/s). The velocity of flow (v), moreover, has to be matched to the physical properties of the fluid:

- $v < 2$ m/s (6.56 ft/s): For abrasive media such as cleaning agents etc.
 - $v > 2$ m/s (6.56 ft/s): For media that produce buildup, such as oil and liquids that contain sugar
-  A necessary increase in the flow velocity can be achieved by reducing the sensor nominal diameter.
-  Flow characteristic values →  59

6.3 Post-installation check

Is the device undamaged (visual inspection)?	<input type="checkbox"/>
Does the measuring device conform to the measuring point specifications? For example: <ul style="list-style-type: none"> ▪ Process temperature ▪ Process pressure →  65 ▪ Ambient temperature →  63 ▪ Measuring range 	<input type="checkbox"/>
Horizontal position of the measuring electrode plane?	<input type="checkbox"/>
Has the correct orientation for the sensor been selected ? <ul style="list-style-type: none"> ▪ According to sensor type ▪ According to medium temperature ▪ According to medium properties (outgassing, with entrained solids) 	<input type="checkbox"/>
Does the arrow on the sensor nameplate match the direction of flow of the fluid through the piping ?	<input type="checkbox"/>
Are the measuring point identification and labeling correct (visual inspection)?	<input type="checkbox"/>
Is the measuring device adequately protected against vibration (attachment, support)?	<input type="checkbox"/>
Are the inlet and outlet runs to respected? →  18	<input type="checkbox"/>

7 Electrical connection

 The measuring device does not have an internal circuit breaker. For this reason, assign the measuring device a switch or power-circuit breaker so that the power supply line can be easily disconnected from the mains.

7.1 Connection conditions

7.1.1 Requirements for connecting cable

The connecting cables provided by the customer must fulfill the following requirements.



Electrical safety

In accordance with applicable federal/national regulations.

Permitted temperature range

- -40 °C (-40 °F) to $+80\text{ °C}$ ($+176\text{ °F}$)
- Minimum requirement: cable temperature range \geq ambient temperature $+20\text{ K}$

Signal cable

 Cables are not included in the scope of delivery; they can be ordered as an accessory →  57.

Pulse/frequency/switch output

Standard installation cable is sufficient.

7.1.2 Terminal assignment

Connection is solely by means of device plug →  25.

7.1.3 Pin assignment, device plug

Device version: 2 pulse/frequency/switch outputs

Order code for "Output, input", option 3:

2 Pulse/frequency/switch output

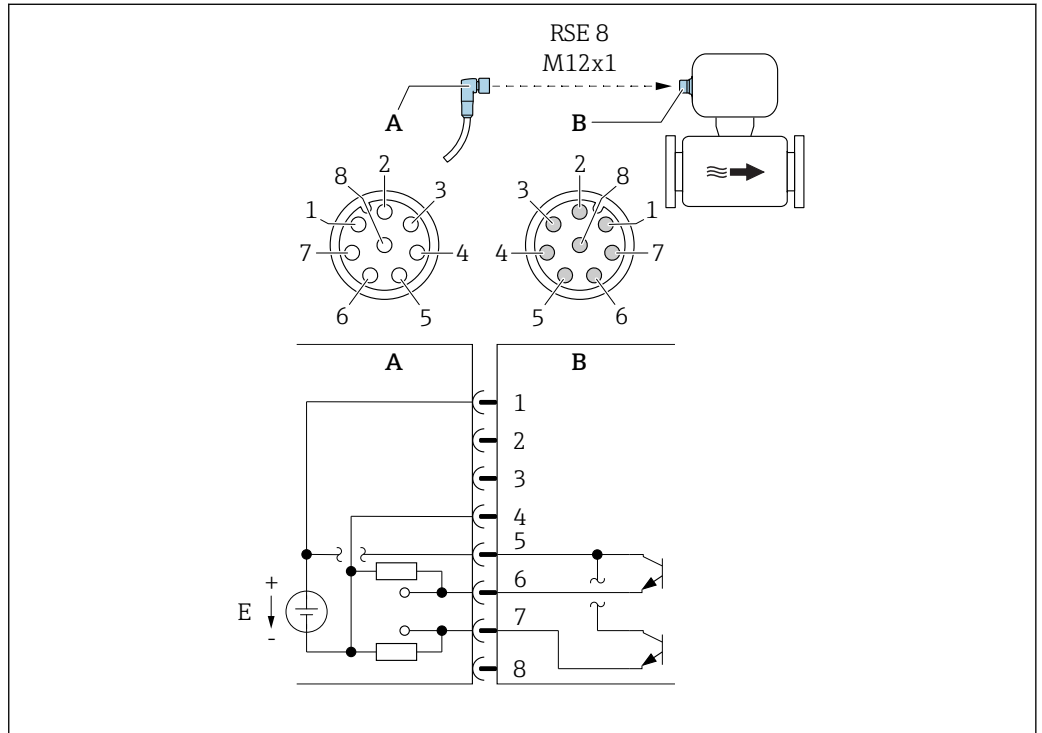

A0032569

6 Connection to device

A Coupling: Supply voltage, pulse/freq./switch output

B Connector: Supply voltage, pulse/freq./switch output

E PELV or SELV power supply

1 to 8 Pin assignment

8

Pin assignment

Connection: Coupling (A) – Connector (B)		
Pin	Assignment	
1	L+	Supply voltage
2	+	Service interface RX
3	+	Service interface TX
4	L-	Supply voltage
5	+	Pulse/frequency/switch output
6	-	Pulse/frequency/switch output 1
7	-	Pulse/frequency/switch output 2
8	-	Service interface GND

7.1.4 Requirements for the supply unit

Supply voltage

DC 24 V (nominal voltage: DC 20 to 30 V)

- i** The power unit must be tested to ensure that it meets safety requirements (e.g. PELV, SELV).
- The supply voltage must not exceed a maximum short-circuit current of 50 A.

7.2 Connecting the measuring device

NOTICE

Limitation of electrical safety due to incorrect connection!

- ▶ Have electrical connection work carried out by correspondingly trained specialists only.
- ▶ Observe applicable federal/national installation codes and regulations.
- ▶ Comply with local workplace safety regulations.

7.2.1 Connecting the transmitter

Connection by means of device plug

Connection is solely by means of device plug.

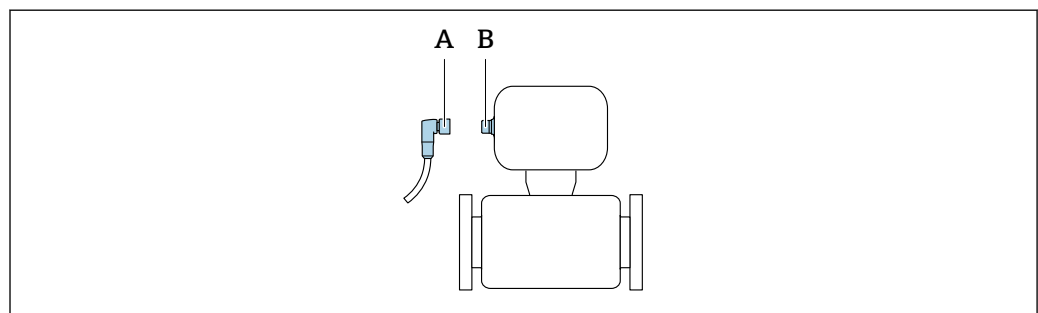

A0032652

- A Coupling
- B Plug

Grounding

Grounding is by means of a cable socket.

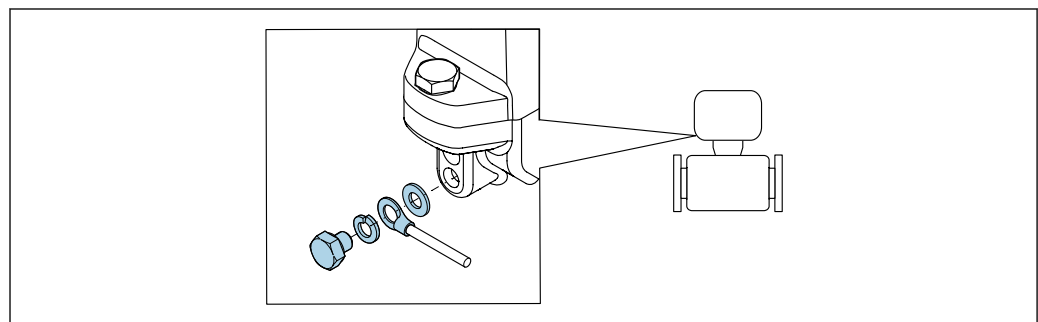

A0003838

7.3 Ensuring the degree of protection

The measuring device fulfills all the requirements for IP67 degree of protection, Type 4X enclosure.

To guarantee IP67 degree of protection, Type 4X enclosure, carry out the following steps after the electrical connection:

- ▶ Tighten all device plugs.

7.4 Post-connection check

Is the device undamaged (visual inspection)?	<input type="checkbox"/>
Does the supply voltage in the system match the specifications on the device's nameplate?	<input type="checkbox"/>
Do the cables used comply with the necessary specifications?	<input type="checkbox"/>
Are the maximum values for voltage and current at the pulse and status output being observed? →  60	<input type="checkbox"/>

8 Operation options

8.1 Overview of operation options

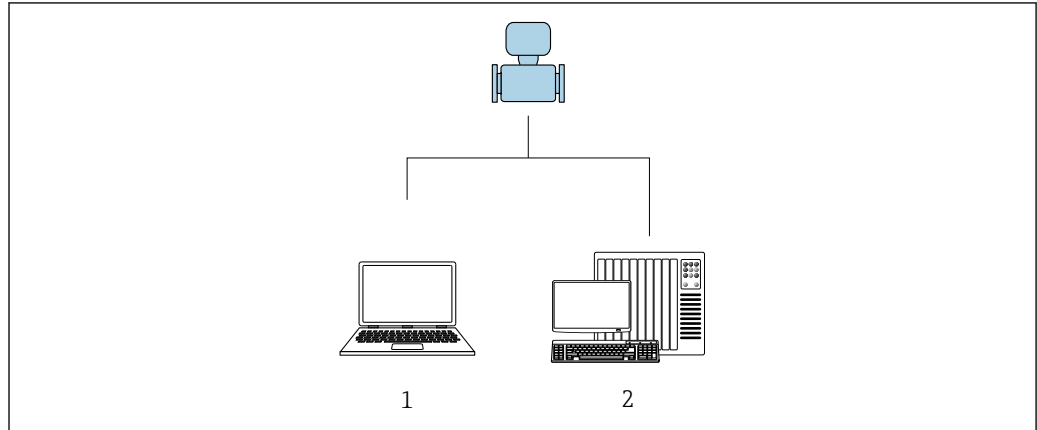

A0017760

- 1 Computer with "FieldCare" or "DeviceCare" operating tool
- 2 Control system (e.g. PLC)

8.2 Access to the operating menu via the operating tool

8.2.1 Connecting the operating tool

Using the service adapter and Commubox FXA291

Operation and configuration can be performed using the Endress+Hauser FieldCare or DeviceCare service and configuration software.

The device is connected to the USB port of the computer via the service adapter and Commubox FXA291.

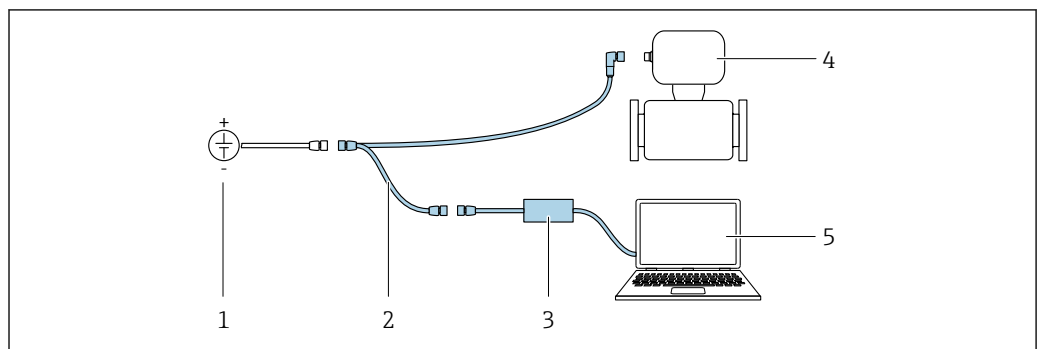

A0032567

- 1 Supply voltage 24 V DC
- 2 Service adapter
- 3 Dosimag
- 4 Commubox FXA291
- 5 Computer with "FieldCare" or "DeviceCare" operating tool

i The service adapter, cable and Commubox FXA291 are not included in the delivery. These components can be ordered as accessories → 57.

8.2.2 FieldCare

Function scope

FDT-based plant asset management tool from Endress+Hauser. It can configure all smart field devices in a system and helps you manage them. By using the status information, it is also a simple but effective way of checking their status and condition.

Access is via:

Service adapter and Commubox FXA291

Typical functions:

- Configuring parameters of transmitters
- Loading and saving device data (upload/download)
- Documentation of the measuring point
- Visualization of the measured value memory (line recorder) and event logbook



For additional information about FieldCare, see Operating Instructions BA00027S and BA00059S

Source for device description files

See information →  31

Establishing a connection

Service adapter, Commubox FXA291 and "FieldCare" operating tool

1. Start FieldCare and launch the project.
2. In the network: Add a device.
 - ↳ The **Add device** window opens.
3. Select the **CDI Communication FXA291** option from the list and press **OK** to confirm.
4. Right-click **CDI Communication FXA291** and select the **Add device** option in the context menu that opens.
5. Select the desired device from the list and press **OK** to confirm.
6. Establish the online connection to the device.



For additional information, see Operating Instructions BA00027S and BA00059S

User interface

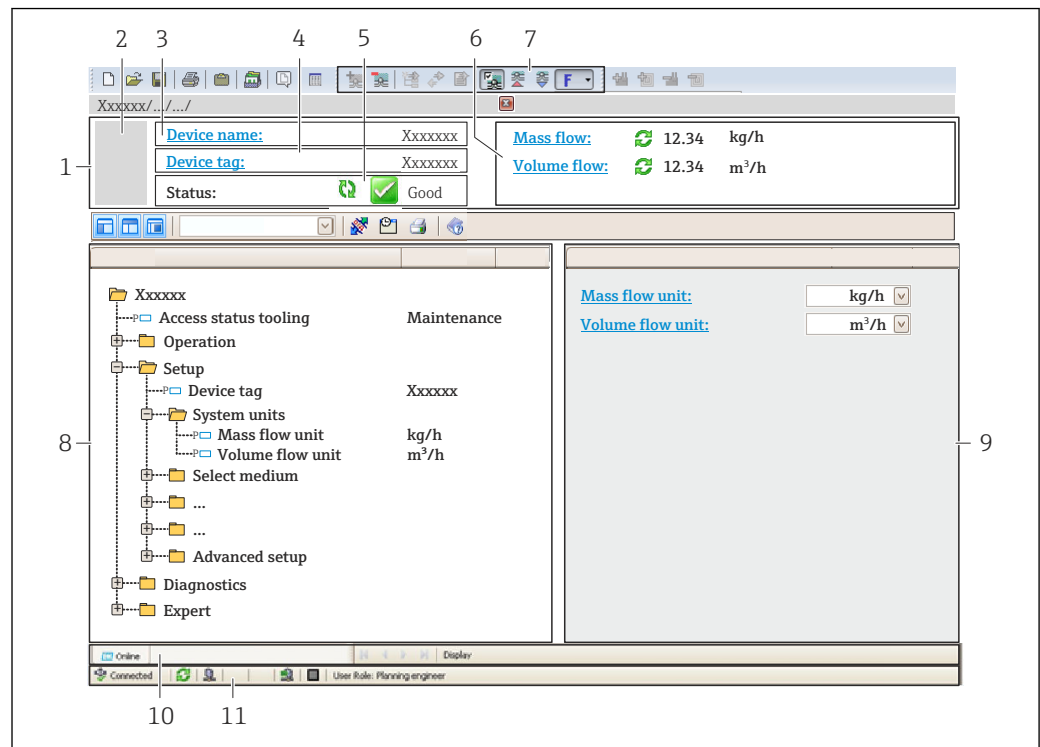

A0021051-EN

- 1 Header
- 2 Picture of device
- 3 Device name
- 4 Tag name
- 5 Status area with status signal
- 6 Display area for current measured values
- 7 Edit toolbar with additional functions such as save/restore, event list and create documentation
- 8 Navigation area with operating menu structure
- 9 Working area
- 10 Range of action
- 11 Status area

8.2.3 DeviceCare

Function scope

Tool to connect and configure Endress+Hauser field devices.

The fastest way to configure Endress+Hauser field devices is with the dedicated "DeviceCare" tool. Together with the device type managers (DTMs) it presents a convenient, comprehensive solution.

 For details, see Innovation Brochure IN01047S

Source for device description files



See information →  31

9 System integration

9.1 Overview of device description files

9.1.1 Current version data for the device

Firmware version	03.00.zz	<ul style="list-style-type: none"> ▪ On the title page of the Operating instructions ▪ On transmitter nameplate ▪ Firmware version ▪ Diagnostics menu → Device information submenu → Firmware version parameter
Release date of firmware version	05.2015	---

 For an overview of the different firmware versions for the device →  52

9.1.2 Operating tools



The suitable device description file for the individual operating tools is listed in the table below, along with information on where the file can be acquired.

Operating tool	Sources for obtaining device descriptions
FieldCare	<ul style="list-style-type: none"> ▪ www.endress.com → Download Area ▪ CD-ROM (contact Endress+Hauser) ▪ DVD (contact Endress+Hauser)
DeviceCare	<ul style="list-style-type: none"> ▪ www.endress.com → Download Area ▪ CD-ROM (contact Endress+Hauser) ▪ DVD (contact Endress+Hauser)

10 Commissioning

10.1 Function check

Before commissioning the measuring device:

- ▶ Make sure that the post-installation and post-connection checks have been performed.
 - "Post-installation check" checklist →  23
 - "Post-connection check" checklist →  27

10.2 Switching on the measuring device

- ▶ The function check has been completed successfully.
Switch on the supply voltage.
 - ↳ The measuring device runs through internal test functions.

The device is operational and operation commences.

 If the device does not start up successfully, depending on the cause, a diagnostic message is displayed in the system asset management tool "FieldCare".

10.3 Establishing a connection via FieldCare

- For FieldCare connection
- For establishing a connection via FieldCare →  29
- For FieldCare user interface →  30

10.4 Configuring the measuring device

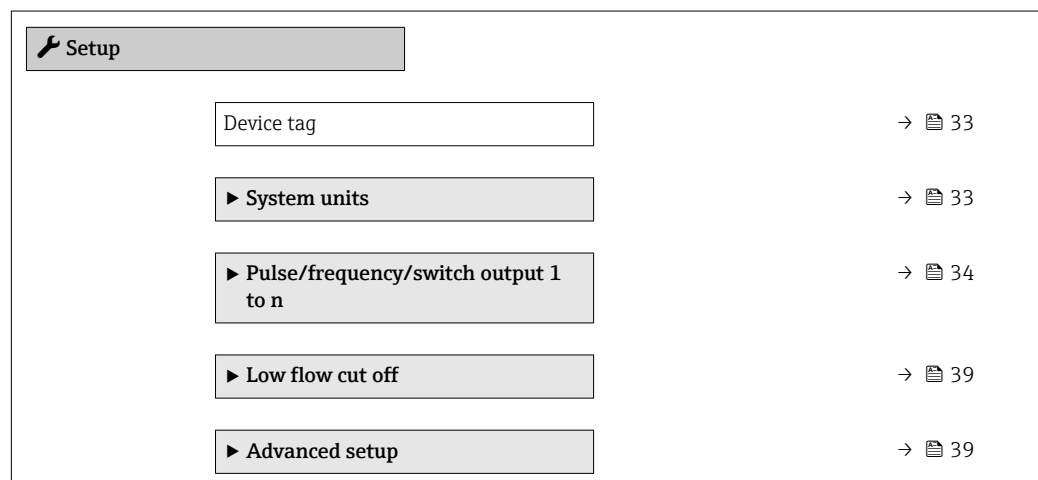

The **Setup** menu with its submenus contains all the parameters needed for standard operation.

Navigation
"Setup" menu



10.4.1 Defining the tag name

To enable fast identification of the measuring point within the system, you can enter a unique designation using the **Device tag** parameter and thus change the factory setting.

-  The number of characters displayed depends on the characters used.
- Enter the tag name in the "FieldCare" operating tool →  30

Navigation

"Setup" menu → Device tag

Parameter overview with brief description

Parameter	Description	User entry	Factory setting
Device tag	Enter the name for the measuring point.	A maximum of 32 characters such as letters, numbers or special characters (e.g. @, %, /)	Dosimag

10.4.2 Setting the system units

In the **System units** submenu the units of all the measured values can be set.

Navigation

"Setup" menu → System units

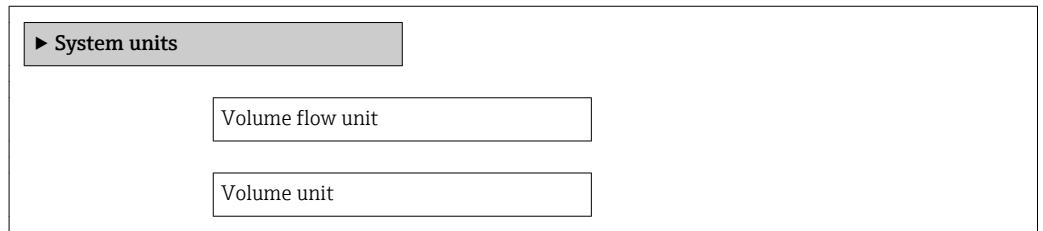

Parameter overview with brief description

Parameter	Description	Selection	Factory setting
Volume flow unit	Select volume flow unit. <i>Result</i> The selected unit applies for: <ul style="list-style-type: none"> Output Low flow cut off Simulation process variable 	Unit choose list	Country-specific: <ul style="list-style-type: none"> ml/s fl oz/s (us)
Volume unit	Select volume unit.	Unit choose list	Country-specific: <ul style="list-style-type: none"> ml fl oz (us)

10.4.3 Configuring the pulse/frequency/switch output

The **Pulse/frequency/switch output 1 to n** submenu contains all the parameters that must be configured for the configuration of the selected output type.

Configuring the pulse output

In the **Operating mode** parameter (→ 34), one of the two options can be selected for the pulse output:

- **Pulse** option: Quantity-proportional pulse with pulse width to be configured.
- **Automatic pulse** option: Quantity-proportional pulse with on/off ratio of 1:1

Navigation

"Setup" menu → Pulse/frequency/switch output 1 to n

Structure of submenu for pulse output

▶ Pulse/frequency/switch output 1 to n

Parameter overview with brief description

Parameter	Prerequisite	Description	Selection / User entry	Factory setting
Operating mode	–	Define the output as a pulse, frequency or switch output.	<ul style="list-style-type: none"> ▪ Off ▪ Pulse ▪ Automatic pulse ▪ Frequency ▪ Switch 	<ul style="list-style-type: none"> ▪ Pulse/frequency/switch output 1 submenu: Pulse option ▪ Pulse/frequency/switch output 1 to n submenu: Switch option
Channel 2	The Pulse option is selected in the Operating mode parameter.	Select impulse with or without time offset.	<ul style="list-style-type: none"> ▪ Off ▪ Redundant 0° ▪ Redundant 90° ▪ Redundant 180° 	Off
Assign pulse output	One of the following options is selected in the Operating mode parameter: <ul style="list-style-type: none"> ▪ Pulse ▪ Automatic pulse 	Select process variable for pulse output.	<ul style="list-style-type: none"> ▪ Off ▪ Volume flow 	Off

Parameter	Prerequisite	Description	Selection / User entry	Factory setting
Value per pulse	<p>One of the following options is selected in the Operating mode parameter:</p> <ul style="list-style-type: none"> ▪ Pulse ▪ Automatic pulse <p>In the Assign pulse output parameter (→ 34), the Volume flow option is selected.</p>	Enter measured value at which a pulse is output.	Signed floating-point number	<p>Depends on the nominal diameter:</p> <ul style="list-style-type: none"> ▪ DN 4 (1/8"): 0.005 ml (0.0002 fl oz) ▪ DN 8 (3/8"): 0.02 ml (0.001 fl oz) ▪ DN 15 (1/2"): 0.1 ml (0.004 fl oz) ▪ DN 15K (1/2K"): 0.1 ml (0.004 fl oz) ▪ DN 25 (1"): 0.2 ml (0.007 fl oz)
Pulse width	In the Operating mode parameter, the Pulse option is selected and in the Assign pulse output parameter (→ 34), the Volume flow option is selected.	Define time width of the output pulse.	0.05 to 3.75 ms	0.05 ms
Failure mode	<p>One of the following options is selected in the Operating mode parameter:</p> <ul style="list-style-type: none"> ▪ Pulse ▪ Automatic pulse <p>In the Assign pulse output parameter (→ 34), the Volume flow option is selected.</p>	Define output behavior in alarm condition.	<ul style="list-style-type: none"> ▪ Actual value ▪ No pulses 	Actual value
Invert output signal	–	Invert the output signal.	<ul style="list-style-type: none"> ▪ No ▪ Yes 	<ul style="list-style-type: none"> ▪ Pulse/freq./switch output 1: yes ▪ Pulse/freq./switch output 2: no

Configuring the frequency output

Flow-proportional frequency output with on/off ratio of 1:1

Navigation

"Setup" menu → Pulse/frequency/switch output 1 to n

Structure of the submenu for the frequency output

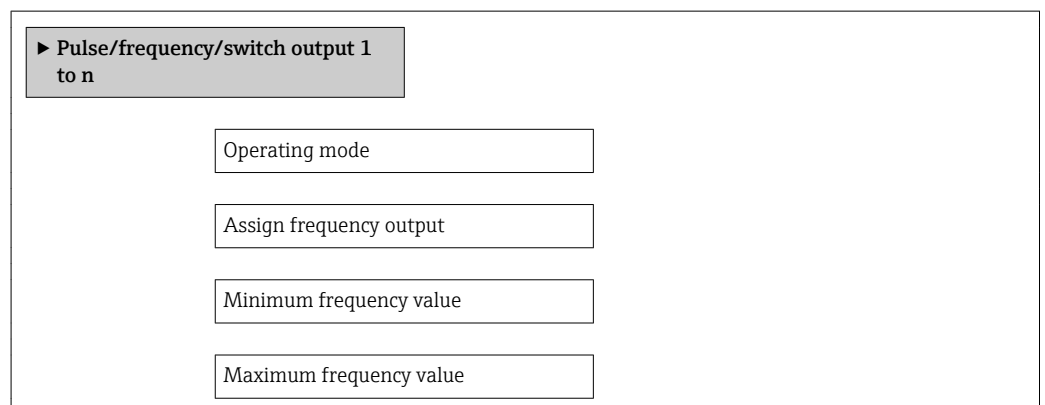

Measuring value at maximum frequency
Failure mode
Failure frequency
Invert output signal

Parameter overview with brief description

Parameter	Prerequisite	Description	Selection / User entry	Factory setting
Operating mode	–	Define the output as a pulse, frequency or switch output.	<ul style="list-style-type: none"> ▪ Off ▪ Pulse ▪ Automatic pulse ▪ Frequency ▪ Switch 	<ul style="list-style-type: none"> ▪ Pulse/frequency/switch output 1 submenu: Pulse option ▪ Pulse/frequency/switch output 1 to n submenu: Switch option
Assign frequency output	The Frequency option is selected in the Operating mode parameter (→ 34).	Select process variable for frequency output.	<ul style="list-style-type: none"> ▪ Off ▪ Volume flow 	Off
Minimum frequency value	In the Operating mode parameter, the Frequency option is selected and in the Assign frequency output parameter (→ 36), the Volume flow option is selected.	Enter minimum frequency.	0.0 to 10 000.0 Hz	0.0 Hz
Maximum frequency value	In the Operating mode parameter, the Frequency option is selected and in the Assign frequency output parameter (→ 36), the Volume flow option is selected.	Enter maximum frequency.	0.0 to 10 000.0 Hz	10 000.0 Hz
Measuring value at maximum frequency	In the Operating mode parameter (→ 34), the Frequency option is selected and in the Assign frequency output parameter (→ 36), the Volume flow option is selected.	Enter measured value for maximum frequency.	Signed floating-point number	Depends on country and nominal diameter
Failure mode	In the Operating mode parameter (→ 34), the Frequency option is selected and in the Assign frequency output parameter (→ 36), the Volume flow option is selected.	Define output behavior in alarm condition.	<ul style="list-style-type: none"> ▪ Actual value ▪ Defined value ▪ 0 Hz 	0 Hz

Parameter	Prerequisite	Description	Selection / User entry	Factory setting
Failure frequency	In the Operating mode parameter (→ 34), the Frequency option is selected and in the Assign frequency output parameter (→ 36), the Volume flow option is selected.	Enter frequency output value in alarm condition.	0.0 to 10000.0 Hz	0.0 Hz
Invert output signal	–	Invert the output signal.	<ul style="list-style-type: none"> ▪ No ▪ Yes 	<ul style="list-style-type: none"> ▪ Pulse/freq./switch output 1: yes ▪ Pulse/freq./switch output 2: no

Configuring the switch output

Navigation

"Setup" menu → Pulse/frequency/switch output 1 to n

Structure of the submenu for the switch output

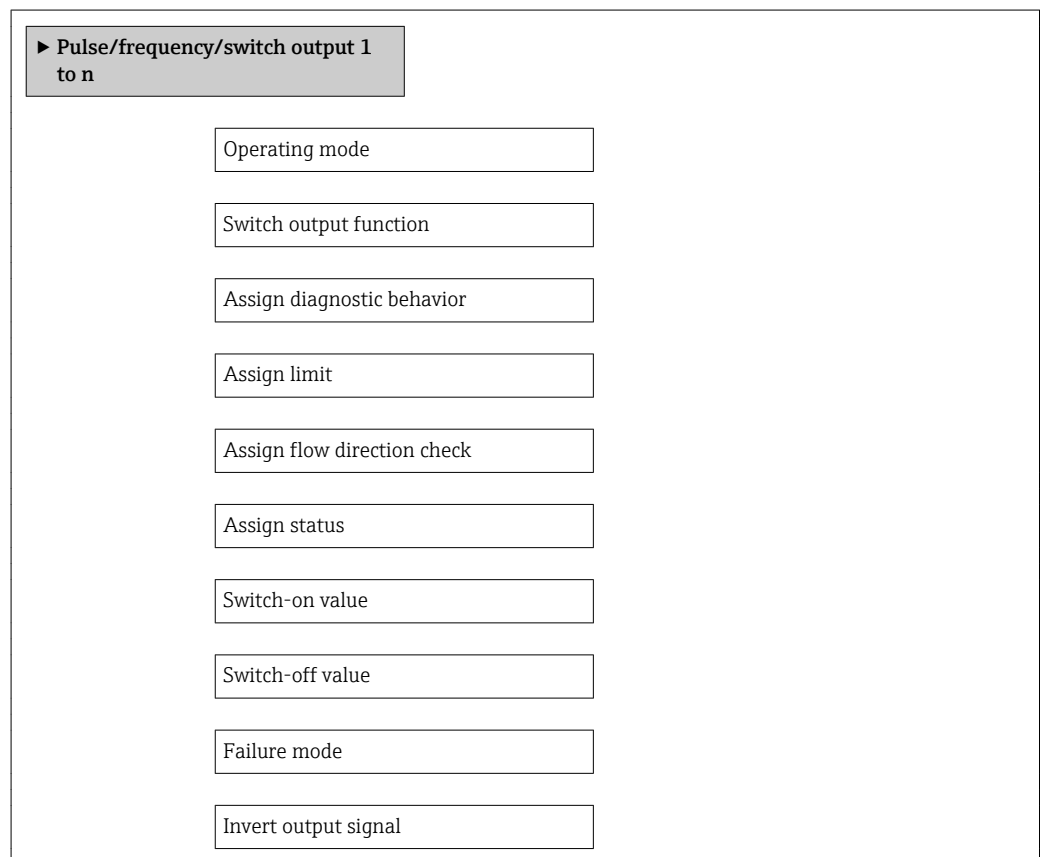

Parameter overview with brief description

Parameter	Prerequisite	Description	Selection / User entry	Factory setting
Operating mode	–	Define the output as a pulse, frequency or switch output.	<ul style="list-style-type: none"> ▪ Off ▪ Pulse ▪ Automatic pulse ▪ Frequency ▪ Switch 	<ul style="list-style-type: none"> ▪ Pulse/frequency/switch output 1 submenu: Pulse option ▪ Pulse/frequency/switch output 1 to n submenu: Switch option
Switch output function	The Switch option is selected in the Operating mode parameter.	Select function for switch output.	<ul style="list-style-type: none"> ▪ Off ▪ On ▪ Diagnostic behavior ▪ Limit ▪ Flow direction check ▪ Status 	Off
Assign diagnostic behavior	<ul style="list-style-type: none"> ▪ The Switch option is selected in the Operating mode parameter. ▪ The Diagnostic behavior option is selected in the Switch output function parameter. 	Select diagnostic behavior for switch output.	<ul style="list-style-type: none"> ▪ Alarm ▪ Alarm or warning ▪ Warning 	Alarm
Assign limit	<ul style="list-style-type: none"> ▪ The Switch option is selected in the Operating mode parameter. ▪ The Limit option is selected in the Switch output function parameter. 	Select process variable for limit function.	Volume flow	Volume flow
Assign flow direction check	<ul style="list-style-type: none"> ▪ The Switch option is selected in the Operating mode parameter. ▪ The Flow direction check option is selected in the Switch output function parameter. 	Select process variable for flow direction monitoring.	<ul style="list-style-type: none"> ▪ Off ▪ Volume flow 	Volume flow
Assign status	<ul style="list-style-type: none"> ▪ The Switch option is selected in the Operating mode parameter. ▪ The Status option is selected in the Switch output function parameter. 	Select device status for switch output.	Low flow cut off	Low flow cut off
Switch-on value	<ul style="list-style-type: none"> ▪ The Switch option is selected in the Operating mode parameter. ▪ The Limit option is selected in the Switch output function parameter. 	Enter measured value for the switch-on point.	Signed floating-point number	Country-specific: <ul style="list-style-type: none"> ▪ 0 ml/s ▪ 0 fl oz/s
Switch-off value	<ul style="list-style-type: none"> ▪ The Switch option is selected in the Operating mode parameter. ▪ The Limit option is selected in the Switch output function parameter. 	Enter measured value for the switch-off point.	Signed floating-point number	Country-specific: <ul style="list-style-type: none"> ▪ 0 ml/s ▪ 0 fl oz/s

Parameter	Prerequisite	Description	Selection / User entry	Factory setting
Failure mode	–	Define output behavior in alarm condition.	<ul style="list-style-type: none"> ■ Actual status ■ Open ■ Closed 	Open
Invert output signal	–	Invert the output signal.	<ul style="list-style-type: none"> ■ No ■ Yes 	<ul style="list-style-type: none"> ■ Pulse/freq./switch output 1: yes ■ Pulse/freq./switch output 2: no

10.4.4 Low flow cut off

The **Low flow cut off** submenu contains the parameters that must be set in order to configure the low flow cut off.

Navigation

"Setup" menu → Low flow cut off

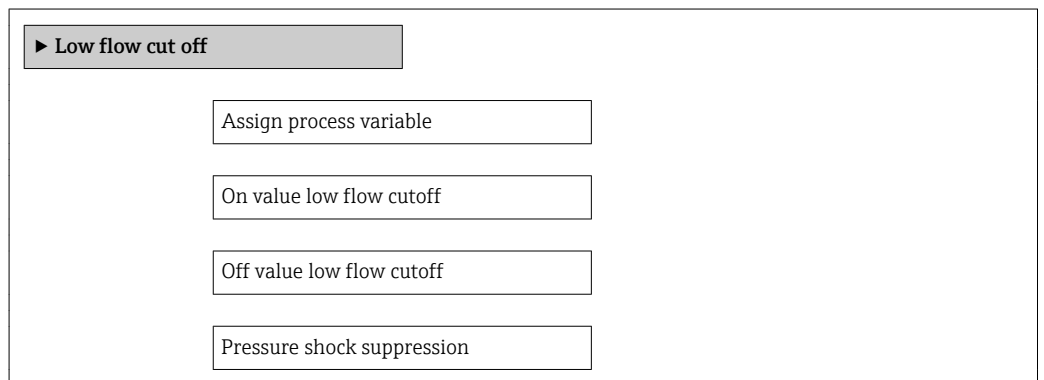

Parameter overview with brief description

Parameter	Prerequisite	Description	Selection / User entry	Factory setting
Assign process variable	–	Select process variable for low flow cut off.	<ul style="list-style-type: none"> ■ Off ■ Volume flow 	Volume flow
On value low flow cutoff	In the Assign process variable parameter (→ 39), the Volume flow option is selected.	Enter on value for low flow cut off.	Signed floating-point number	Depends on country and nominal diameter
Off value low flow cutoff	In the Assign process variable parameter (→ 39), the Volume flow option is selected.	Enter off value for low flow cut off.	0 to 100.0 %	50 %
Pressure shock suppression	In the Assign process variable parameter (→ 39), the Volume flow option is selected.	Enter time frame for signal suppression (= active pressure shock suppression).	0 to 100 s	0 s

10.5 Advanced settings

The **Advanced setup** submenu together with its submenus contains parameters for specific settings.

Navigation

"Setup" menu → Advanced setup

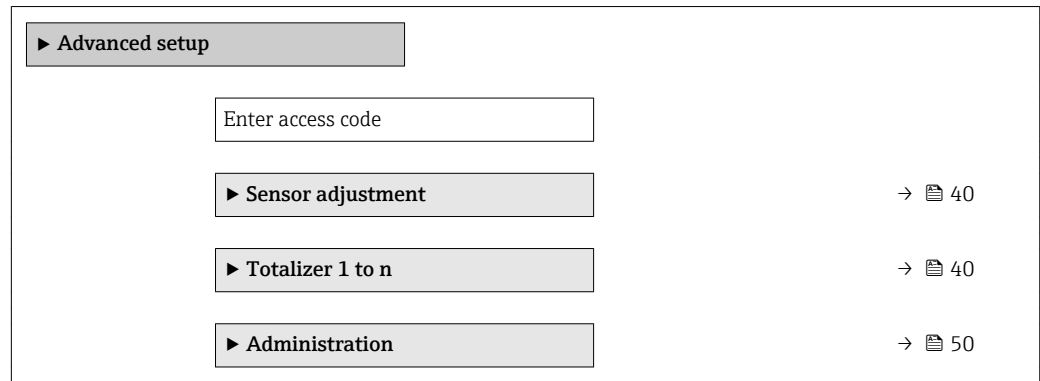

10.5.1 Sensor adjustment

The **Sensor adjustment** submenu contains parameters that pertain to the functionality of the sensor.

Navigation

"Setup" menu → Advanced setup → Sensor adjustment

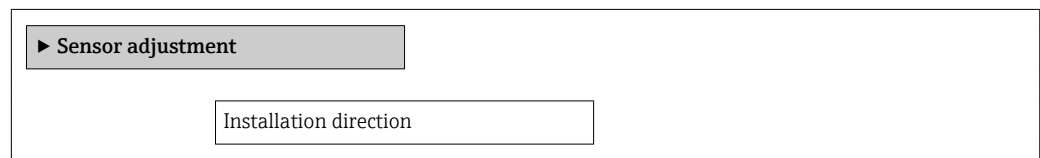

Parameter overview with brief description

Parameter	Description	Selection	Factory setting
Installation direction	Set sign of flow direction to match the direction of the arrow on the sensor.	<ul style="list-style-type: none"> ■ Flow in arrow direction ■ Flow against arrow direction 	Flow in arrow direction

10.5.2 Configuring the totalizer

The totalizer in question can be configured in the **Totalizer 1 to n** submenu.

Navigation

"Setup" menu → Advanced setup → Totalizer 1 to n

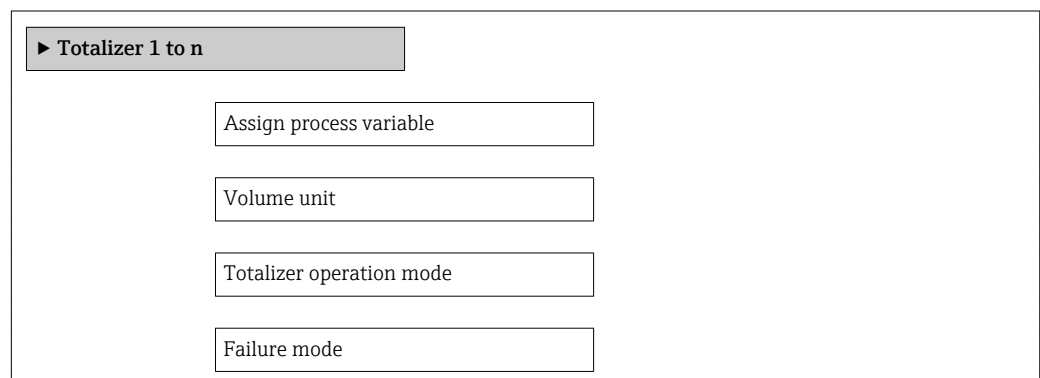

Parameter overview with brief description

Parameter	Prerequisite	Description	Selection	Factory setting
Assign process variable	–	Select process variable for totalizer.	<ul style="list-style-type: none"> ▪ Off ▪ Volume flow 	Volume flow
Volume unit	The Volume flow option is selected in the Assign process variable parameter (→ 41) of the Totalizer 1 to n submenu.	Select volume unit.	Unit choose list	Depending on country: <ul style="list-style-type: none"> ▪ ml ▪ fl oz (us)
Totalizer operation mode	In the Assign process variable parameter (→ 41) of the Totalizer 1 to n submenu, the Volume flow option is selected.	Select totalizer calculation mode.	<ul style="list-style-type: none"> ▪ Net flow total ▪ Forward flow total ▪ Reverse flow total 	Net flow total
Failure mode	In the Assign process variable parameter (→ 41) of the Totalizer 1 to n submenu, the Volume flow option is selected.	Define totalizer behavior in alarm condition.	<ul style="list-style-type: none"> ▪ Stop ▪ Actual value ▪ Last valid value 	Stop

10.6 Simulation

The **Simulation** submenu enables you to simulate, without a real flow situation, various process variables in the process and the device alarm mode and to verify downstream signal chains (switching valves or closed-control loops).

Navigation

"Diagnostics" menu → Simulation

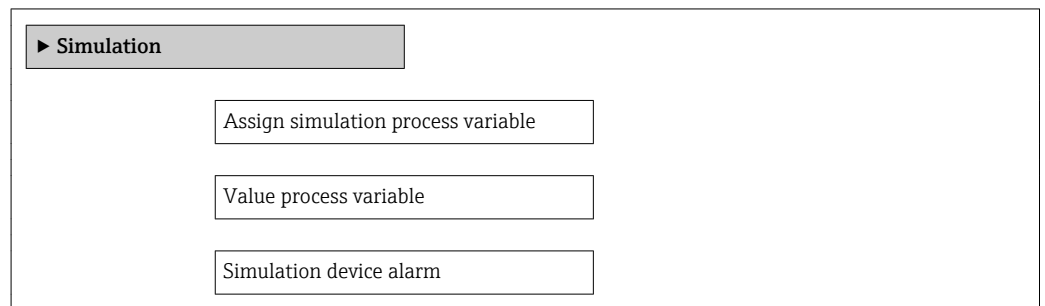

Parameter overview with brief description

Parameter	Prerequisite	Description	Selection / User entry	Factory setting
Assign simulation process variable	–	Select a process variable for the simulation process that is activated.	<ul style="list-style-type: none"> ▪ Off ▪ Volume flow 	Off
Value process variable	In the Assign simulation process variable parameter (→ 41), the Volume flow option is selected.	Enter the simulation value for the selected process variable.	Depends on the process variable selected	0
Simulation device alarm	–	Switch the device alarm on and off.	<ul style="list-style-type: none"> ▪ Off ▪ On 	Off

11 Operation

11.1 Reading device locking status

Device active write protection: **Locking status** parameter

Navigation

"Operation" menu → Locking status

Function scope of "Locking status" parameter

Options	Description
Temporarily locked	Write access to the parameters is temporarily lock due to device-internal processing (e.g. data upload/download, reset). Once the internal processing has been completed, the parameters can be changed once again.

Parameter overview with brief description

Parameter	Description	User interface	Factory setting
Locking status	Indicates the write protection with the highest priority that is currently active.	Temporarily locked	Temporarily locked

11.2 Reading access authorization status on operating software

Displaying active access authorization: **Access status tooling** parameter

Navigation

"Operation" menu → Access status tooling

Parameter overview with brief description

Parameter	Description	User interface	Factory setting
Access status tooling	Shows the access authorization to the parameters via the operating tool.	<ul style="list-style-type: none"> ▪ Operator ▪ Maintenance 	Maintenance

11.3 Reading measured values

With the **Measured values** submenu, it is possible to read all the measured values.

11.3.1 Process variables

The **Process variables** submenu contains all the parameters needed to display the current measured values for every process variable.

Navigation

"Diagnostics" menu → Measured values → Process variables

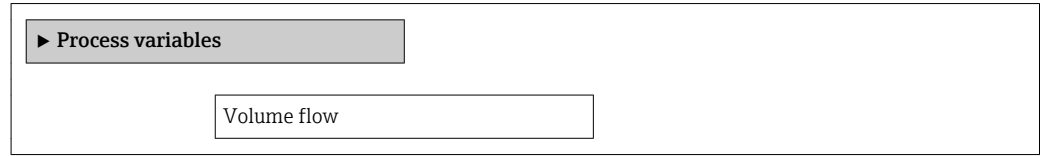

Parameter overview with brief description

Parameter	Description	User interface
Volume flow	Displays the volume flow currently measured. <i>Dependency</i> The unit is taken from the Volume flow unit parameter	Signed floating-point number

11.3.2 Totalizer

The **Totalizer** submenu contains all the parameters needed to display the current measured values for every totalizer.

Navigation

"Diagnostics" menu → Measured values → Totalizer

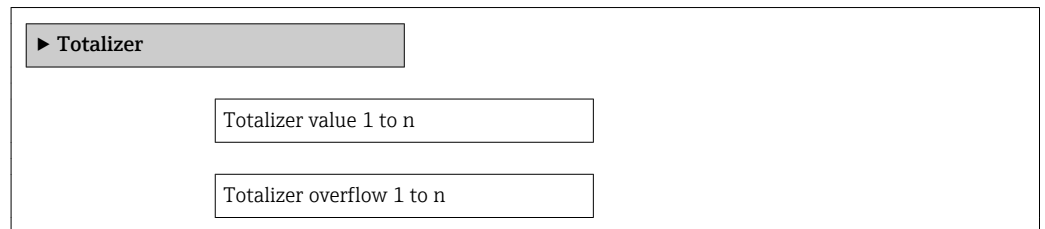

Parameter overview with brief description

Parameter	Prerequisite	Description	User interface
Totalizer value	In the Assign process variable parameter (→ 41) of the Totalizer 1 to n submenu, the Volume flow option is selected.	Displays the current totalizer counter value.	Signed floating-point number
Totalizer overflow	In the Assign process variable parameter (→ 41) of the Totalizer 1 to n submenu, the Volume flow option is selected.	Displays the current totalizer overflow.	Integer with sign

11.3.3 Output values

The **Output values** submenu contains all the parameters needed to display the current measured values for every output.

Navigation

"Diagnostics" menu → Measured values → Output values

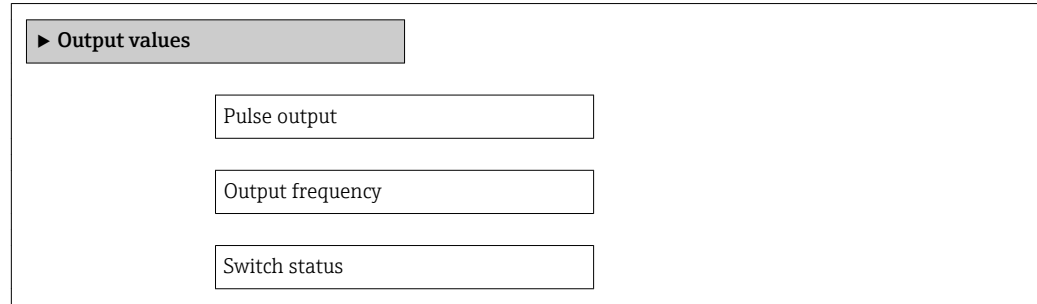

Parameter overview with brief description

Parameter	Prerequisite	Description	User interface
Pulse output	One of the following options is selected in the Operating mode parameter: <ul style="list-style-type: none"> ▪ Pulse ▪ Automatic pulse 	Displays the pulse frequency currently output.	Positive floating-point number
Output frequency	The Frequency option is selected in the Operating mode parameter.	Displays the value currently measured for the frequency output.	0.0 to 10 000.0 Hz
Switch status	The Switch option is selected in the Operating mode parameter.	Displays the current switch output status.	<ul style="list-style-type: none"> ▪ Open ▪ Closed

11.4 Performing a totalizer reset

Function scope of the "Control Totalizer" parameter

Options	Description
Totalize	The totalizer is started.
Reset + hold	The totaling process is stopped and the totalizer is reset to 0.
Preset + hold	The totaling process is stopped and the totalizer is set to its defined start value from the Preset value parameter.
Reset + totalize	The totalizer is reset to 0 and the totaling process is restarted.
Preset + totalize	The totalizer is set to the defined start value in the Preset value parameter and the totaling process is restarted.
Hold	Totalizing is stopped.

Function scope of the "Reset all totalizers" parameter

Options	Description
Reset + totalize	Resets all totalizers to 0 and restarts the totaling process. This deletes all the flow values previously totalized.

Navigation

"Operation" menu → Totalizer handling

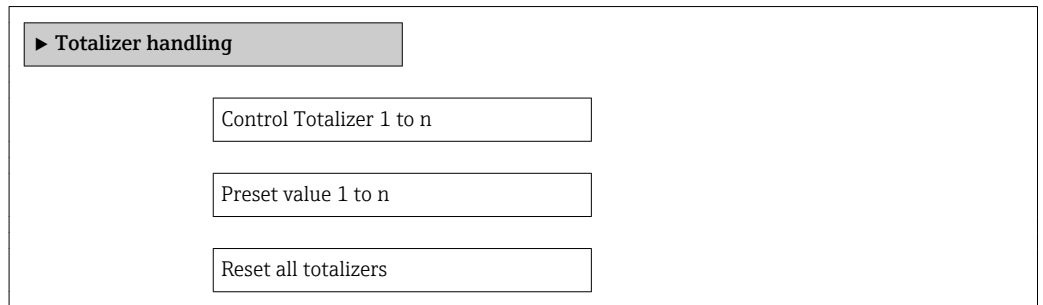

Parameter overview with brief description

Parameter	Prerequisite	Description	Selection / User entry	Factory setting
Control Totalizer	In the Assign process variable parameter (→ 41) of the Totalizer 1 to n submenu, the Volume flow option is selected.	Control totalizer value.	<ul style="list-style-type: none"> ■ Totalize ■ Reset + hold ■ Preset + hold ■ Reset + totalize ■ Preset + totalize 	Totalize
Preset value	In the Assign process variable parameter (→ 41) of the Totalizer 1 to n submenu, the Volume flow option is selected.	Specify start value for totalizer. <i>Dependency</i>  The unit of the selected process variable is specified for the totalizer in the Assign process variable parameter. If the following is selected in the Assign process variable parameter: Volume flow option: Volume flow unit parameter	Signed floating-point number	Country-specific: <ul style="list-style-type: none"> ■ 0 m³ ■ 0 ft³
Reset all totalizers	–	Reset all totalizers to 0 and start.	<ul style="list-style-type: none"> ■ Cancel ■ Reset + totalize 	Cancel

12 Diagnostics and troubleshooting

12.1 General troubleshooting

For access

Problem	Possible causes	Remedy
No write access to parameters	Current user role has limited access authorization	Check access authorization status .
No connection via service adapter	Incorrect configuration of USB interface on PC or driver not installed correctly.	Observe the documentation for the Commubox.  FXA291: Document "Technical Information" TI00405C

12.2 Diagnostic information in FieldCare

12.2.1 Diagnostic options

Any faults detected by the measuring device are displayed on the home page of the operating tool once the connection has been established.

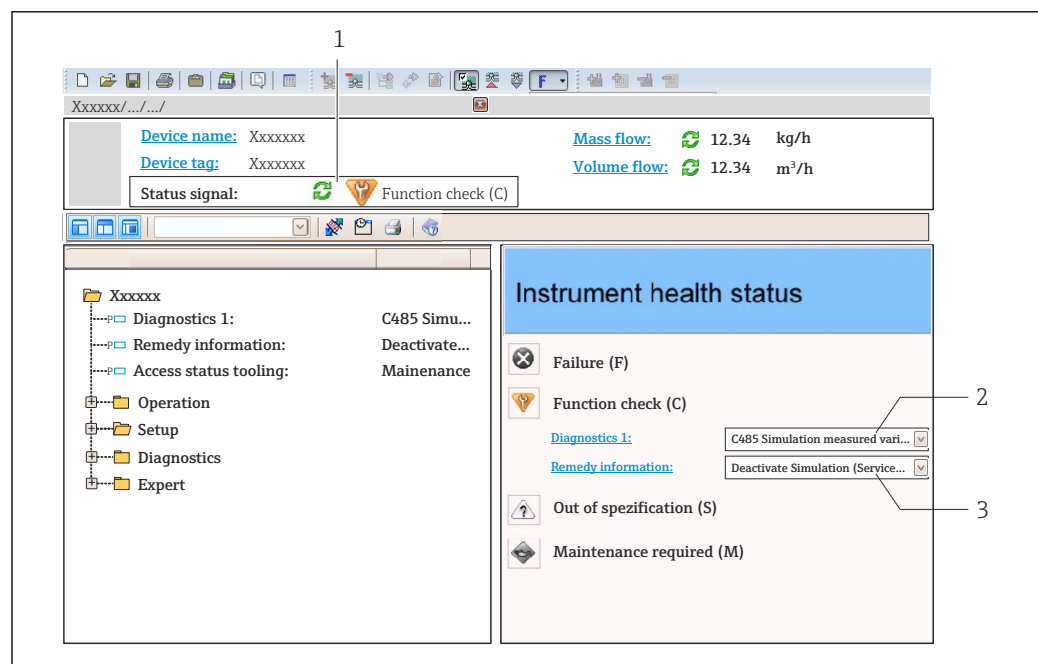

A0021799-EN

- 1 Status area with status signal
- 2 Diagnostic information →  47
- 3 Remedy information with Service ID

 Furthermore, diagnostic events that have occurred can be viewed in the **Diagnostics** menu:

- Via parameter
- Via submenu →  50

Diagnostic information

The fault can be identified using the diagnostic information. The short text helps you by providing information about the fault.

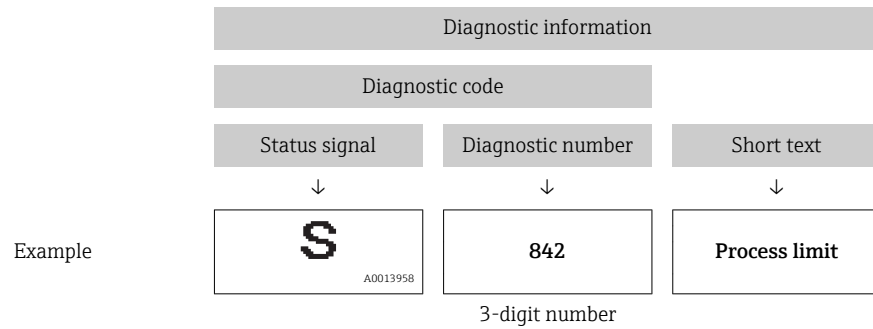

12.2.2 Calling up remedy information

Remedy information is provided for every diagnostic event to ensure that problems can be rectified quickly:

- On the home page
Remedy information is displayed in a separate field below the diagnostics information.
- In the **Diagnostics** menu
Remedy information can be called up in the working area of the user interface.

The user is in the **Diagnostics** menu.

1. Call up the desired parameter.
2. On the right in the working area, mouse over the parameter.
↳ A tool tip with remedy information for the diagnostic event appears.

12.3 Adapting the diagnostic information

12.3.1 Adapting the diagnostic behavior



Each item of diagnostic information is assigned a specific diagnostic behavior at the factory. The user can change this assignment for certain diagnostic information in the **Diagnostic behavior** submenu.

Expert → System → Diagnostic handling → Diagnostic behavior

You can assign the following options to the diagnostic number as the diagnostic behavior:

Options	Description
Alarm	Measurement is interrupted. Signal outputs and totalizers assume the defined alarm condition. A diagnostic message is generated.
Warning	Measurement is resumed. The signal outputs and totalizers are not affected. A diagnostic message is generated.
Logbook entry only	The device continues to measure. The diagnostic message is entered in the Event logbook (events list) submenu only and is not displayed in alternation with the measured value display.
Off	The diagnostic event is ignored, and no diagnostic message is generated or entered.

12.4 Overview of diagnostic information

 In the case of some items of diagnostic information, the status signal and the diagnostic behavior can be changed. Change the diagnostic information →  47

Diagnostic number	Short text	Remedy instructions	Status signal [from the factory]	Diagnostic behavior [from the factory]
Diagnostic of sensor				
004	Sensor	1. Change sensor 2. Contact service	S	Alarm
062	Sensor connection	1. Check sensor connections 2. Contact service	F	Alarm
082	Data storage	1. Check module connections 2. Contact service	F	Alarm
083	Memory content	1. Restart device 2. Contact service	F	Alarm
Diagnostic of electronic				
242	Software incompatible	1. Check software 2. Flash or change main electronics module	F	Alarm
270	Main electronic failure	Change main electronic module	F	Alarm
271	Main electronic failure	1. Restart device 2. Change main electronic module	F	Alarm
272	Main electronic failure	1. Restart device 2. Contact service	F	Alarm
273	Main electronic failure	Change electronic	F	Alarm
281	Electronic initialization	Firmware update active, please wait!	F	Alarm
311	Electronic failure	1. Reset device 2. Contact service	F	Alarm
322	Electronic drift	1. Perform verification manually 2. Change electronic	S	Warning
Diagnostic of configuration				
410	Data transfer	1. Check connection 2. Retry data transfer	F	Alarm
411	Up-/download active	Up-/download active, please wait	C	Warning
438	Dataset	1. Check data set file 2. Check device configuration 3. Up- and download new configuration	M	Warning
442	Frequency output 1 to n	1. Check process 2. Check frequency output settings	S	Warning ¹⁾
443	Pulse output 1 to n	1. Check process 2. Check pulse output settings	S	Warning ¹⁾
453	Flow override	Deactivate flow override	C	Warning
484	Simulation failure mode	Deactivate simulation	C	Alarm
485	Simulation measured variable	Deactivate simulation	C	Warning
500	Electrode difference voltage too high	1. Check process cond. 2. Increase system pressure	F	Alarm
Diagnostic of process				
832	Electronic temperature too high	Reduce ambient temperature	S	Warning ¹⁾
833	Electronic temperature too low	Increase ambient temperature	S	Warning ¹⁾



Diagnostic number	Short text	Remedy instructions	Status signal [from the factory]	Diagnostic behavior [from the factory]
834	Process temperature too high	Reduce process temperature	S	Warning ¹⁾
835	Process temperature too low	Increase process temperature	S	Warning ¹⁾
937	EMC interference	Change main electronic module	S	Warning ¹⁾
938	EMC interference	1. Check ambient conditions regarding EMC influence 2. Change main electronic module	F	Alarm
991	Batch time exceeded	Check process conditions	F	Warning ¹⁾
991	Maximum flow rate exceeded		F	Warning ¹⁾

1) Diagnostic behavior can be changed.

12.5 Pending diagnostic events

The **Diagnostics** menu provides the option of displaying the current and previous diagnostic event separately.

 To call up the measures to rectify a diagnostic event:
Via the DeviceCare and FieldCare operating tool →  47

 Other pending diagnostic events can be displayed in the **Diagnostic list** submenu →  50

Navigation

"Diagnostics" menu

Structure of the submenu

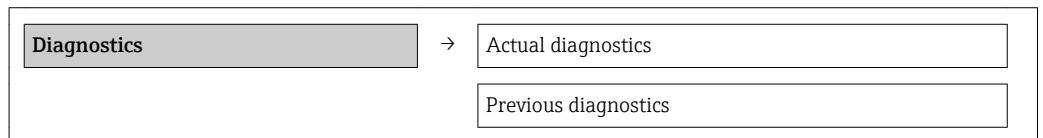

Parameter overview with brief description



Parameter	Prerequisite	Description	User interface
Actual diagnostics	A diagnostic event has occurred.	Shows the current occurred diagnostic event along with its diagnostic information.  If two or more messages occur simultaneously, the message with the highest priority is shown on the display.	Symbol for diagnostic behavior, diagnostic code and short message.
Previous diagnostics	Two diagnostic events have already occurred.	Shows the diagnostic event that occurred prior to the current diagnostic event along with its diagnostic information.	Symbol for diagnostic behavior, diagnostic code and short message.

12.6 Diagnostic list

In the **Diagnostic list** submenu, up to 5 currently pending diagnostic events can be displayed along with the related diagnostic information. If more than 5 diagnostic events are pending, the events with the highest priority are shown on the display.



Navigation path

Diagnostics menu → **Diagnostic list** submenu

 To call up the measures to rectify a diagnostic event:
Via "FieldCare" operating tool →  47

12.7 Event logbook

12.7.1 Event history

 To call up the measures to rectify a diagnostic event:
Via "FieldCare" operating tool →  47

 For filtering the displayed event messages →  50

12.7.2 Filtering the event logbook

Using the **Filter options** parameter, you can define which category of event messages is displayed in the **Events list** submenu.

Navigation path

"Diagnostics" menu → Event logbook → Filter options

Filter categories

- All
- Failure (F)
- Function check (C)
- Out of specification (S)
- Maintenance required (M)
- Information (I)

12.7.3 Overview of information events

Unlike a diagnostic event, an information event is displayed in the event logbook only and not in the diagnostic list.

Info number	Info name
I1000	----- (Device ok)
I1089	Power on
I1090	Configuration reset
I1091	Configuration changed
I1110	Write protection switch changed
I1151	History reset

12.8 Resetting the measuring device

The device can be reset in the **Administration** submenu.

Navigation

"Expert" menu → System → Administration

▶ Administration

Device reset

Parameter overview with brief description

Parameter	Description	Selection	Factory setting
Device reset	Reset the device configuration - either entirely or in part - to a defined state.	<ul style="list-style-type: none"> ▪ Cancel ▪ To delivery settings ▪ Restart device 	Cancel

12.9 Device information

The **Device information** submenu contains all parameters that display different information for device identification.

Navigation

"Diagnostics" menu → Device information

▶ Device information

Device tag

Serial number

Firmware version

Device name

Order code





Extended order code 1

Extended order code 2

Extended order code 3

ENP version

Parameter overview with brief description

Parameter	Description	User entry / User interface	Factory setting
Device tag	Enter the name for the measuring point.	A maximum of 32 characters such as letters, numbers or special characters (e.g. @, %, /)	Dosimag
Serial number	Shows the serial number of the measuring device.	A maximum of 11-digit character string comprising letters and numbers.	–
Firmware version	Shows the device firmware version installed.	Character string with the following format: xx.yy.zz	03.00
Device name	Shows the name of the transmitter.  The name can be found on the nameplate of the transmitter.	Dosimag	–
Order code	Shows the device order code.  It can be found in the "Order code" field on the nameplate.	Character string composed of letters, numbers and certain punctuation marks (e.g. /).	–
Extended order code 1	Shows the 1st part of the extended order code.  It can be found in the "Ext. ord. cd." field on the nameplate.	Character string	–
Extended order code 2	Shows the 2nd part of the extended order code.  The extended order code can also be found on the nameplate of the sensor and transmitter in the "Ext. ord. cd." field.	Character string	–
Extended order code 3	Shows the 3rd part of the extended order code.  The extended order code can also be found on the nameplate of the sensor and transmitter in the "Ext. ord. cd." field.	Character string	–
ENP version	Shows the version of the electronic nameplate (ENP).		2.02.00

12.10 Firmware history

Release date	Firmware version	Order code for "Firmware version"	Firmware changes	Documentation type	Documentation
09.2015	03.00.zz	Option A	No change in firmware	Operating Instructions	BA00098D/06/EN/14.15
08.2014	03.00.zz	Option A	<ul style="list-style-type: none"> ▪ New original firmware ▪ Can be operated via FieldCare and DeviceCare 	Operating Instructions	BA00098D/06/EN/13.14
08.2012	01.01.zz	–	No change in firmware	Operating Instructions	BA00097D/06/EN/14.12
05.2006	02.02.zz	–	New functionality: <ul style="list-style-type: none"> ▪ Automatic pulse width ▪ On-value and off-value status output 	Operating Instructions	BA098D/06/EN/05.06

Release date	Firmware version	Order code for "Firmware version"	Firmware changes	Documentation type	Documentation
07.2005	02.01.zz	–	Additional "Symmetry" option for pulse output.	Operating Instructions	BA098D/06/EN/10.05
12.2003	01.00.zz	–	<ul style="list-style-type: none"> ■ Original firmware ■ Compatible with FieldCare 	Operating Instructions	BA098D/06/EN/04.04

 For the compatibility of the firmware version with the previous version, the installed device description files and operating tools, observe the information about the device in the "Manufacturer's information" document.

-  The manufacturer's information is available:
- In the Downloads area of the Endress+Hauser web site: www.endress.com → Downloads
 - Specify the following details:
 - Product root: e.g. 5RH
 - Text search: Manufacturer's information
 - Media type: Documentation – Technical Documentation

13 Maintenance

13.1 Maintenance tasks

No special maintenance work is required.

13.1.1 Exterior cleaning

When cleaning the exterior of measuring devices, always use cleaning agents that do not attack the surface of the housing or the seals.

13.1.2 Interior cleaning

Observe the following points for CIP and SIP cleaning:

- Use only cleaning agents to which the process-wetted materials are adequately resistant.
- Observe the maximum permitted medium temperature for the measuring device .

13.1.3 Replacing seals

The sensor's seals (particularly aseptic molded seals) must be replaced periodically.

The interval between changes depends on the frequency of the cleaning cycles, the cleaning temperature and the medium temperature.

Replacement seals (accessory part) →  57

13.2 Measuring and test equipment

Endress+Hauser offers a wide variety of measuring and test equipment, such as W@M or device tests.

 Your Endress+Hauser Sales Center can provide detailed information on the services.

 For a list of some of the measuring and test equipment, refer to the "Accessories" chapter of the "Technical Information" document for the device.

13.3 Endress+Hauser services

Endress+Hauser offers a wide variety of services for maintenance such as recalibration, maintenance service or device tests.

 Your Endress+Hauser Sales Center can provide detailed information on the services.

14 Repair

14.1 General notes

Repair and conversion concept

The Endress+Hauser repair and conversion concept provides for the following:

- The measuring device cannot be converted.
- If the measuring device is defective, the entire device is replaced.
- It is possible to replace seals.

Information on replacing wear parts (seals)

Please note the following when replacing wear parts:

- Use only original Endress+Hauser spare parts.
- Replace the part according to the Installation Instructions.
- Observe the applicable standards, federal/national regulations, Ex documentation (XA) and certificates.
- Document every repair and each conversion and enter them into the *W@M* life cycle management database.

14.2 Spare parts

W@M Device Viewer (www.endress.com/deviceviewer):

All the spare parts for the measuring device, along with the order code, are listed here and can be ordered. If available, users can also download the associated Installation Instructions.



Measuring device serial number:

- Is located on the nameplate of the device.
- Can be read out via the **Serial number** parameter in the **Device information** submenu → 51.

14.3 Endress+Hauser services

Endress+Hauser offers a wide range of services.



Your Endress+Hauser Sales Center can provide detailed information on the services.

14.4 Return

The measuring device must be returned if it is need of repair or a factory calibration, or if the wrong measuring device has been delivered or ordered. Legal specifications require Endress+Hauser, as an ISO-certified company, to follow certain procedures when handling products that are in contact with the medium.

To ensure safe, swift and professional device returns, please refer to the procedure and conditions for returning devices provided on the Endress+Hauser website at

<http://www.endress.com/support/return-material>

14.5 Disposal

14.5.1 Removing the measuring device

1. Switch off the device.

2. ⚠ WARNING**Danger to persons from process conditions.**

- ▶ Beware of hazardous process conditions such as pressure in the measuring device, high temperatures or aggressive fluids.

Carry out the mounting and connection steps from the chapters "Mounting the measuring device" and "Connecting the measuring device" in the logically reverse sequence. Observe the safety instructions.

14.5.2 Disposing of the measuring device

⚠ WARNING**Danger to personnel and environment from fluids that are hazardous to health.**

- ▶ Ensure that the measuring device and all cavities are free of fluid residues that are hazardous to health or the environment, e.g. substances that have permeated into crevices or diffused through plastic.

Observe the following notes during disposal:

- Observe valid federal/national regulations.
- Ensure proper separation and reuse of the device components.

15 Accessories



Various accessories, which can be ordered with the device or subsequently from Endress+Hauser, are available for the device. Detailed information on the order code in question is available from your local Endress+Hauser sales center or on the product page of the Endress+Hauser website: www.endress.com.

15.1 Device-specific accessories



15.1.1 For the sensor

Accessories	Description	Order code
Seal set	For regular replacement of the seals on the process connections.	DK5G**-***
Housing seal	To seal the transmitter	50102857
Mounting set	Consists of: <ul style="list-style-type: none"> ▪ 2 process connections ▪ Screws ▪ Seals 	DKH**-****

15.2 Communication-specific accessories

Accessories	Description
FieldCare	FDT-based plant asset management tool from Endress+Hauser. It can configure all smart field units in your system and helps you manage them. By using the status information, it is also a simple but effective way of checking their status and condition.  For details, see Operating Instructions BA00027S and BA00059S
DeviceCare	Tool for connecting and configuring Endress+Hauser field devices.  For details, see Innovation brochure IN01047S
Commubox FXA291	Connects Endress+Hauser field devices with a CDI interface (= Endress+Hauser Common Data Interface) and the USB port of a computer or laptop.  For details, see the "Technical Information" document TI405C/07
Adapter connection	Adapter connections for installation on other electrical connections: <ul style="list-style-type: none"> ▪ Adapter FXA291 (order number: 71035809) ▪ Adapter RSE8 (order number: 50107169) RSE8 connection jack, 8-pin adapter (RSE8), 24 V DC, pulse, status ▪ Adapter RSE5 (order number: 50107168) RSE8 connection jack, 5-pin adapter (RSE5), 24 V DC, pulse, status ▪ Adapter RSE4 (order number: 50107167) RSE8 connection jack, 4-pin adapter (RSE4), 24 V DC, pulse
Connecting cable RSE8	Cable RKWTN8-56/5 P92, length: 5 m (Order number: 50107895)

15.3 Service-specific accessories

Accessories	Description
Applicator	<p>Software for selecting and sizing Endress+Hauser measuring devices:</p> <ul style="list-style-type: none"> ■ Calculation of all data required to determine the optimum flowmeter: e.g. nominal diameter, pressure loss, accuracy or process connections. ■ Graphic illustration of the calculation results <p>Administration, documentation and access to all project-related data and parameters throughout the entire life cycle of a project.</p> <p>Applicator is available:</p> <ul style="list-style-type: none"> ■ Via the Internet: https://wapps.endress.com/applicator ■ On CD-ROM for local PC installation.
W@M	<p>Life cycle management for your plant</p> <p>W@M supports you with a wide range of software applications over the entire process: from planning and procurement, to the installation, commissioning and operation of the measuring devices. All the relevant information is available for every measuring device over time entire life cycle, such as the Device status, spare parts, device-specific documentation.</p> <p>The application already contains the data of your Endress+Hauser device. Endress+Hauser also takes care of maintaining and updating the data records.</p> <p>W@M is available:</p> <ul style="list-style-type: none"> ■ Via the Internet: www.endress.com/lifecyclemanagement ■ On CD-ROM for local PC installation.
FieldCare	<p>FDT-based plant asset management tool from Endress+Hauser.</p> <p>It can configure all smart field units in your system and helps you manage them. By using the status information, it is also a simple but effective way of checking their status and condition.</p> <p> For details, see Operating Instructions BA00027S and BA00059S</p>
DeviceCare	<p>Tool for connecting and configuring Endress+Hauser field devices.</p> <p> For details, see Innovation brochure IN01047S</p>
Commubox FXA291	<p>Connects Endress+Hauser field devices with a CDI interface (= Endress+Hauser Common Data Interface) and the USB port of a computer or laptop.</p> <p> For details, see "Technical Information" TI00405C</p>

16 Technical data



16.1 Application

Depending on the version ordered, the measuring device can also measure potentially explosive, flammable, poisonous and oxidizing media.

To ensure that the device remains in proper operating condition for its service life, use the measuring device only for media against which the process-wetted materials are sufficiently resistant.

16.2 Function and system design

Measuring principle Electromagnetic flow measurement on the basis of *Faraday's law of magnetic induction*.

Measuring system The device consists of a transmitter and a sensor.
 The device is available as a compact version:
 The transmitter and sensor form a mechanical unit.
 For information on the structure of the device →  11 →  11

16.3 Input

Measured variable **Direct measured variables**
 Volume flow (proportional to induced voltage)

Measuring range Typically $v = 0.01$ to 10 m/s (0.03 to 33 ft/s) with specified accuracy

Flow characteristic values in SI units

Nominal diameter [mm]	Recommended flow Max. full scale value [l/s]	Factory settings	
		Pulse value [ml]	Low flow cut off ($v \sim 0.04$ m/s) [ml/s]
4	0.14	0.005	0.5
8	0.5	0.02	2
15K ¹⁾	1.2	0.1	7
15	1.66	0.1	7
25	5	0.2	16

1) Conical version (corresponds to DN 12)

Flow characteristic values in US units

Nominal diameter [in]	Recommended flow Max. full scale value [gal/s]	Factory settings	
		Pulse value [oz fl]	Low flow cut off (v ~ 0.13 ft/s) [oz fl/s]
5/32	0.035	0.0002	0.02
5/16	0.13	0.001	0.08
1/2K ¹⁾	0.32	0.004	0.25
1/2	0.44	0.004	0.25
1	1.33	0.007	0.53

1) Conical version (corresponds to DN 12)

Recommended measuring range

"Flow limit" section → 65

Operable flow range Over 1000 : 1

16.4 Output

Output signal

Pulse/frequency/switch output

Function	Can be set to: <ul style="list-style-type: none"> ▪ Pulse Quantity-proportional pulse with pulse width to be configured. ▪ Automatic pulse Quantity-proportional pulse with on/off ratio of 1:1 ▪ Frequency Flow-proportional frequency output with on/off ratio of 1:1 ▪ Switch Contact for displaying a status
Channel 2	Redundant output of pulse output: 0°, 90° or 180°
Version	Passive, open emitter
Maximum input values	<ul style="list-style-type: none"> ▪ DC 30 V ▪ 25 mA
Voltage drop	At 25 mA: ≤ DC 2 V
Pulse output	
Pulse width	Adjustable: 0.05 to 3.75 ms
Maximum pulse rate	10 000 Impulse/s
Pulse value	Adjustable
Assignable measured variables	Volume flow
Frequency output	
Output frequency	Adjustable: 0 to 10 000 Hz
Damping	Adjustable: 0 to 999.9 s
Pulse/pause ratio	1:1
Assignable measured variables	Volume flow

Switch output	
Switching behavior	Binary, conductive or non-conductive
Number of switching cycles	Unlimited
Assignable functions	<ul style="list-style-type: none"> ▪ Off ▪ On ▪ Diagnostic behavior <ul style="list-style-type: none"> - Alarm - Alarm and warning - Warning ▪ Limit value: <ul style="list-style-type: none"> - Off - Volume flow - Flow velocity ▪ Status <ul style="list-style-type: none"> Low flow cut off

Signal on alarm

Depending on the interface, failure information is displayed as follows:

Pulse/frequency/switch output

Pulse output

Failure mode	Choose from: <ul style="list-style-type: none"> ▪ Actual value ▪ No pulses
--------------	--

Frequency output

Failure mode	Choose from: <ul style="list-style-type: none"> ▪ Actual value ▪ 0 Hz ▪ Defined value: 0 to 10 000 Hz
--------------	--

Switch output

Failure mode	Choose from: <ul style="list-style-type: none"> ▪ Current status ▪ Open ▪ Closed
--------------	---

Low flow cut off

The switch points for low flow cut off are user-selectable.

Galvanic isolation

- Pulse/frequency/switch outputs galvanically isolated from supply potential.
- Pulse/frequency/switch outputs not galvanically isolated from each other.

16.5 Power supply

Terminal assignment

→  24

Pin assignment, device plug

→  25

Supply voltage DC 24 V (nominal voltage: DC 20 to 30 V)

-  The power unit must be tested to ensure that it meets safety requirements (e.g. PELV, SELV).
- The supply voltage must not exceed a maximum short-circuit current of 50 A.

Power consumption 4.5 W

Order code for "Output, input":	Maximum Power consumption
Option 3: 2 pulse/frequency/switch outputs	225 mA

 Switch-on current: max. 1 A (< 8 ms)

Power supply failure

- Totalizers stop at the last value measured.
- Error messages (incl. total operated hours) are stored.

Electrical connection →  26

Potential equalization **Requirements**
 No potential matching is needed for grounded steel lines.

 For devices intended for use in hazardous locations, please observe the guidelines in the Ex documentation (XA).

Cable specification →  24

16.6 Performance characteristics

Reference operating conditions **In accordance with DIN EN 29104**

- Medium temperature: +28 ± 2 °C (+82 ± 4 °F)
- Ambient temperature: +22 ± 2 °C (+72 ± 4 °F)
- Warm-up period: 30 min

Installation

- Inlet run > 10 × DN
- Outlet run > 5 × DN
- Sensor and transmitter grounded.
- The sensor is centered in the pipe.

Maximum measured error **Error limits under reference operating conditions**
 o.r. = of reading

Volume flow

- ±0.25 % o.r. ± 1 to 4 m/s (3.3 to 13 ft/s) or
- ±0.5 % o.r. ± 1 mm/s (0.04 in/s) or
- ±5 % o.r.

 Fluctuations in the supply voltage do not have any effect within the specified range.

Accuracy of outputs

The outputs have the following base accuracy specifications.

Pulse/frequency output

o.r. = of reading

Accuracy	Max. ±50 ppm o.r. (across the entire ambient temperature range)
-----------------	---

Repeatability

o.r. = of reading

DN 25 (500 ml/s), DN 15 (200 ml/s), DN 8 (50 ml/s), DN 4 (10 ml/s); 400 µS/cm

Batch time t_a [s]	Relative standard deviation in relation to the batched volume [%]
1.5 s < t_a < 3 s	0.4
3 s < t_a < 5 s	0.2
5 s < t_a	0.1

DN 15K (200 ml/s); 400 µS/cm

Batch time t_a [s]	Relative standard deviation in relation to the batched volume [%]
1.5 s < t_a < 3 s	0.25
3 s < t_a < 5 s	0.12
5 s < t_a	0.08

Influence of ambient temperature

Pulse/frequency output

Temperature coefficient	No additional effect. Included in accuracy.
--------------------------------	---



16.7 Installation

"Mounting requirements"

16.8 Environment

Ambient temperature range

Temperature tables

-  Observe the interdependencies between the permitted ambient and fluid temperatures when operating the device in hazardous areas.
-  For detailed information on the temperature tables, see the separate document entitled "Safety Instructions" (XA) for the device.

Storage temperature

The storage temperature corresponds to the ambient temperature range of the transmitter and sensor.

- Protect the measuring device against direct sunlight during storage in order to avoid unacceptably high surface temperatures.
- Select a storage location where moisture cannot collect in the measuring device as fungus or bacteria infestation can damage the liner.
- If protection caps or protective covers are mounted these should never be removed before installing the measuring device.



Degree of protection As standard: IP67, type 4X enclosure

Shock resistance Acceleration up to 2 g based on IEC 60068-2-6

Vibration resistance Acceleration up to 2 g based on IEC 60068-2-6

Interior cleaning

- Cleaning in place (CIP)
- Sterilization in place (SIP)

 Observe the maximum medium temperatures →  64

Electromagnetic compatibility (EMC) According to IEC/EN 61326

 For details, refer to the Declaration of Conformity.

16.9 Process

Medium temperature range **Sensor**
-20 to +130 °C (-4 to +266 °F)

Cleaning
+150 °C (+302 °F) / 60 min for CIP and SIP processes

Seals

- EPDM: -20 to +130 °C (-4 to +266 °F) (max. +150 °C (302 °F) for cleaning)
- Silicon: -20 to +130 °C (-4 to +266 °F)
- Viton: 0 to +150 °C (+32 to +302 °F)

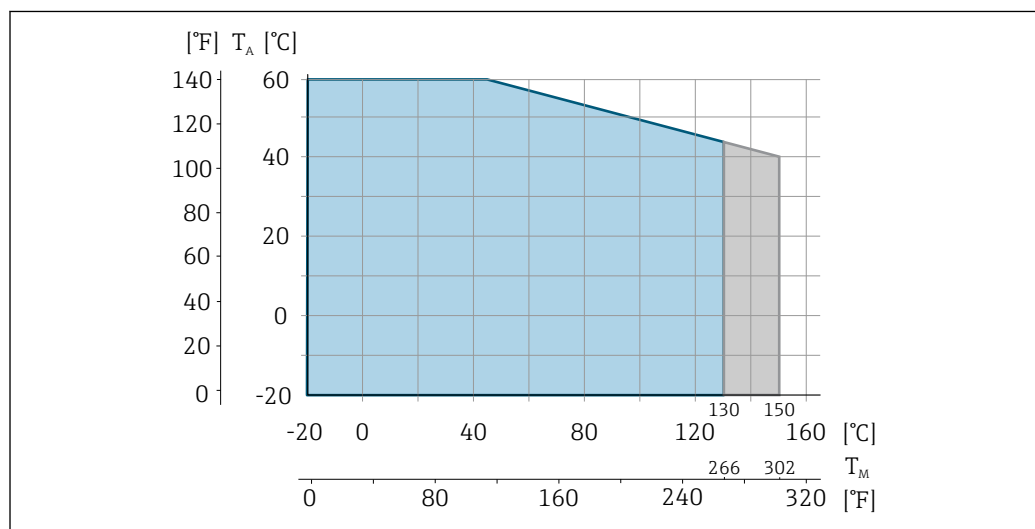

A0004805

- T_A Ambient temperature
- T_M Medium temperature
- Light-gray area: standard fluid temperature range
- Dark-gray area: fluid temperature range for cleaning

- Conductivity
 - ≥ 5 μS/cm for liquids in general
 - ≥ 10 μS/cm for demineralized water



- Pressure-temperature ratings
 -  An overview of the pressure-temperature ratings for the process connections is provided in the "Technical Information" document

- Pressure tightness *Liner: PFA*

Nominal diameter		Limit values for absolute pressure in [mbar] ([psi]) for fluid temperatures:	
[mm]	[in]	+25 °C (+77 °F)	+150 °C (+302 °F)
4 to 25	⁵ / ₃₂ to 1	> 1 mbar (0.402 inH ₂ O) (0)	> 1 mbar (0.402 inH ₂ O) (0)

- Flow limit

The diameter of the pipe and the flow rate determine the nominal diameter of the sensor. The optimum flow velocity is between 2 to 3 m/s (6.56 to 9.84 ft/s). Also match the velocity of flow (v) to the physical properties of the fluid:

 - v < 2 m/s (6.56 ft/s): For abrasive media (e.g. cleaning agents)
 - v > 2 m/s (6.56 ft/s): For media that produce buildup (e.g. liquids containing oil and sugar)
 -  A necessary increase in the flow velocity can be achieved by reducing the sensor nominal diameter.
 -  For an overview of the full scale values for the measuring range, see the "Measuring range" section →  59

- Pressure loss
 - For DN 8 (5/16"), DN 15 (1/2") and DN 25 (1") no pressure loss occurs if the sensor is installed in a pipe with the same nominal diameter.
 - Pressure losses for configurations incorporating adapters according to DIN EN 545 →  20

- System pressure →  19

Vibrations

16.10 Mechanical construction

- Design, dimensions
 -  For the dimensions and installation lengths of the device, see the "Technical Information" document, "Mechanical construction" section

Weight

Compact version

Weight in SI units

DN [mm]	Weight [kg]
4	2.8
8	2.8
15	2.8
25	4.3

Weight in US units

DN [in]	Weight [lbs]
$\frac{5}{32}$	6.17
$\frac{5}{16}$	6.17
$\frac{1}{2}$	6.17
1	9.48

Materials

Transmitter housing

- Acid and alkali-resistant outer surface
- Stainless steel 1.4308 (304)

Device plugs

Electrical connection	Material
Plug M12x1	<ul style="list-style-type: none"> ■ Socket: Stainless steel, 1.4404 (316L) ■ Contact housing: Polyamide ■ Contacts: Gold-plated brass

Sensor housing

- Acid and alkali-resistant outer surface
- Stainless steel 1.4301 (304)

Measuring tube

Stainless steel 1.4301 (304)

Liner



PFA

Electrodes

- 1.4435 (316L)
- Alloy C22, 2.4602 (UNS N06022)
- Platinum
- Tantalum

Process connections

- Weld-in nipple: 1.4404 (316L)
- Weld-in nipple, aseptic: 1.4404 (316L)
- Tri-Clamp: 1.4404 (316L)
- Couplings: 1.4404 (316L)

 List of all available process connections →  67

Seals

Molded seal (EPDM, silicone, Viton)

Fitted electrodes

- Standard: stainless steel 1.4435 (316L)
- Optional: Alloy C22, 2.4602 (UNS N06022), platinum, tantalum

Process connections

With O-ring seal

Welded connections

- DIN EN ISO 1127
- ODT/SMS

Coupling

ISO 228/DIN 2999

With aseptic molded seal:

Welded connections

- EN 10357, DIN 11850
- ODT/SMS

Tri-Clamp

L14 AM7

 For information on the different materials used in the process connections →  67

Surface roughness

Stainless steel electrodes, 1.4435 (304L); Alloy C22, 2.4602 (UNS N06022), platinum, tantalum:

0.3 to 0.5 µm (11.8 to 19.7 µin)

Liner with PFA:

≤ 0.4 µm (15.7 µin)

Process connection:

≤ 0.8 µm (31 µin)

(All data relate to parts in contact with fluid)

16.11 Operability

Local operation

This device cannot be operated locally using a display or operating elements.

Remote operation

Using service adapter and Commubox FXA291

Operation and configuration can be performed using the Endress+Hauser FieldCare or DeviceCare service and configuration software.

The device is connected to the USB port of the computer via the service adapter and Commubox FXA291.

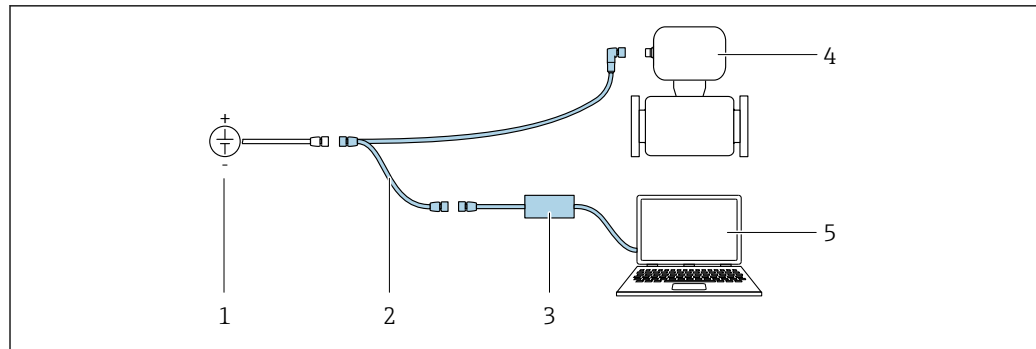

A0032567

- 1 Supply voltage 24 V DC
- 2 Service adapter
- 3 Commubox FXA291
- 4 Measuring device
- 5 Computer with "FieldCare" or "DeviceCare" operating tool

i The service adapter, cable and Commubox FXA291 are not included in the delivery. These components can be ordered as accessories → 57.



16.12 Certificates and approvals

CE mark	<p>The measuring system is in conformity with the statutory requirements of the applicable EC Directives. These are listed in the corresponding EC Declaration of Conformity along with the standards applied.</p> <p>Endress+Hauser confirms successful testing of the device by affixing to it the CE mark.</p>
C-Tick symbol	<p>The measuring system meets the EMC requirements of the "Australian Communications and Media Authority (ACMA)".</p>
Ex approval	<p>The devices are certified for use in hazardous areas and the relevant safety instructions are provided in the separate "Safety Instructions" (XA) document. Reference is made to this document on the nameplate.</p>
Sanitary compatibility	<ul style="list-style-type: none"> ■ 3A approval and EHEDG-certified ■ Seals → FDA-compliant
Pressure Equipment Directive	<ul style="list-style-type: none"> ■ With the PED/G1/x (x = category) marking on the sensor nameplate, Endress+Hauser confirms compliance with the "Essential Safety Requirements" specified in Annex I of the Pressure Equipment Directive 97/23/EC. ■ Devices not bearing this marking (PED) are designed and manufactured according to good engineering practice. They meet the requirements of Art.3 Section 3 of the Pressure Equipment Directive 97/23/EC. The range of application is indicated in tables 6 to 9 in Annex II of the Pressure Equipment Directive.
Measuring instrument approval	<p>Dosimag is suitable as an (optional) component for recording volume in legally regulated measuring systems for AdBlue / DEF (Diesel Exhaust Fluid) in accordance with Appendix MI-005 of the European Measuring Instruments Directive 2014/32/EU. Dosimag is certified in accordance with OIML R117-1:2007 / OIML R117-2:2014 and has an MID evaluation certificate confirming conformity with the basic requirements of the Measuring Instruments Directive.</p>

Other standards and guidelines

- EN 60529
Degrees of protection provided by enclosures (IP code)
- EN 61010-1
Safety Requirements for Electrical Equipment for Measurement, Control and Laboratory Use
- IEC/EN 61326
Emission in accordance with Class A requirements. Electromagnetic compatibility (EMC requirements).
- CAN/CSA C22.2 No. 61010-1-12
Safety Requirements for Electrical Equipment for Measurement, Control and Laboratory Use, Part 1: General Requirements
- ANSI/ISA-61010-1 (82.02.01)
Safety Requirements for Electrical Equipment for Measurement, Control and Laboratory Use – Part 1: General Requirements

16.13 Accessories

 Overview of accessories available for order →  57

16.14 Supplementary documentation

 For an overview of the scope of the associated Technical Documentation, refer to the following:

- The *W@M Device Viewer* : Enter the serial number from the nameplate (www.endress.com/deviceviewer)
- The *Endress+Hauser Operations App*: Enter the serial number from the nameplate or scan the 2-D matrix code (QR code) on the nameplate.

Standard documentation

Brief Operating Instructions

Measuring device	Documentation code
Dosimag	KA01175D

Description of device parameters

Measuring device	Documentation code
	Pulse/frequency/status output Option 3
Dosimag	GP01049D

Technical Information

Measuring device	Documentation code
Dosimag	TI00066D

Supplementary device-
dependent documentation

Safety Instructions

Contents	Documentation code
ATEX/IECEX Ex nA	XA01332D
cCSAus	FES0231
UL Class 1 Division 2	XA01377D

Special Documentation

Contents	Documentation code
Information on Custody Transfer Measurement	SD01514D

Index

A

- Adapters 20
- Adapting the diagnostic behavior 47
- Ambient temperature
 - Influence 63
- Ambient temperature range 19
- Application 8, 59
- Approvals 68

C

- C-Tick symbol 68
- CE mark 9, 68
- Certificates 68
- Check
 - Connection 27
 - Post-installation 23
- Checklist
 - Post-connection check 27
 - Post-installation check 23
- Cleaning
 - Cleaning in place (CIP) 54
 - Exterior cleaning 54
 - Interior cleaning 54
 - Sterilization in place (SIP) 54
- Cleaning in place (CIP) 64
- Commissioning 32
- Conductivity 65
- Connecting cable 24
- Connecting the measuring device 26
 - Grounding 26
- Connecting the transmitter 26
- Connection
 - see Electrical connection
- Connection conditions 24
- Current consumption 62

D

- Declaration of Conformity 9
- Degree of protection 26, 64
- Designated use 8
- Device components 11
- Device description files 31
- Device documentation
 - Supplementary documentation 7
- Device locking, status 42
- Device name
 - Sensor 13
- DeviceCare 30
- Diagnostic information
 - Design, description 47
 - FieldCare 46
 - Overview 47
 - Remedy information 47
- Diagnostic list 50
- Display
 - Current diagnostic event 49

- Previous diagnostic event 49
- Display values
 - For locking status 42
- Disposal 55
- Document
 - Function 5
 - Symbols used 5
- Document function 5
- Down pipe 16

E

- Electrical connection
 - Degree of protection 26
 - Measuring device 24
- Electromagnetic compatibility 64
- Endress+Hauser services
 - Maintenance 54
 - Repair 55
- Environment
 - Ambient temperature 19
 - Shock resistance 64
 - Storage temperature 63
 - Vibration resistance 64
- Error messages
 - see Diagnostic messages
- Event history 50
- Events list 50
- Ex approval 68
- Extended order code
 - Sensor 13
- Exterior cleaning 54

F

- Field of application
 - Residual risks 9
- FieldCare 29
 - Device description file 31
 - Establishing a connection 29
 - Function 29
 - User interface 30
- Filtering the event logbook 50
- Firmware
 - Release date 31
 - Version 31
- Firmware history 52
- Fitted electrodes 67
- Flow direction 17
- Flow limit 65
- Function check 32
- Functions
 - see Parameters

G

- Galvanic isolation 61

I

- Identifying the measuring device 12

- Incoming acceptance 12
 - Influence
 - Ambient temperature 63
 - Information on the document 5
 - Inlet runs 18
 - Input 59
 - Inspection
 - Received goods 12
 - Installation 16
 - Installation 21
 - Installation conditions
 - Adapters 20
 - Down pipe 16
 - Inlet and outlet runs 18
 - Installation dimensions 19
 - Mounting location 16
 - Orientation 17
 - Partially filled pipe 16
 - System pressure 19
 - Vibrations 19
 - Installation dimensions 19
 - Interior cleaning 54, 64
- L**
- Local operation 67
 - Low flow cut off 61
- M**
- Maintenance tasks 54
 - Replacing seals 54
 - Manufacturing date 13
 - Materials 66
 - Maximum measured error 62
 - Measured variables
 - Measured 59
 - see Process variables
 - Measuring and test equipment 54
 - Measuring device 31
 - Disposal 56
 - Mounting the sensor
 - Cleaning with pigs 22
 - Mounting the seals 23
 - Nominal diameter and flow 23
 - Welded connections 22
 - Preparing for mounting 21
 - Removing 55
 - structure 11
 - Switching on 32
 - Measuring instrument approval 68
 - Measuring principle 59
 - Measuring range 59
 - Measuring system 59
 - Media 8
 - Medium temperature range 64
 - Menu
 - Diagnostics 49
 - Operation 42
 - Setup 32, 33
 - Mounting dimensions
 - see Installation dimensions
 - Mounting location 16
 - Mounting preparations 21
 - Mounting tools 21
- N**
- Nameplate
 - Sensor 13
- O**
- Operable flow range 60
 - Operation 42
 - Operation options 28
 - Operational safety 9
 - Order code 13
 - Orientation
 - Filling systems 18
 - Orientation (vertical, horizontal) 17
 - Outlet runs 18
 - Output 60
 - Output signal 60
- P**
- Packaging disposal 15
 - Parameter settings
 - Administration (Submenu) 50
 - Device information (Submenu) 51
 - Diagnostics (Menu) 49
 - Low flow cut off (Submenu) 39
 - Operation (Menu) 42
 - Output values (Submenu) 43
 - Process variables (Submenu) 42
 - Pulse/frequency/switch output 1 to n (Submenu) 34, 35, 37
 - Sensor adjustment (Submenu) 40
 - Setup (Menu) 33
 - Simulation (Submenu) 41
 - System units (Submenu) 33
 - Totalizer (Submenu) 43
 - Totalizer 1 to n (Submenu) 40
 - Totalizer handling (Submenu) 44
 - Partially filled pipe 16
 - Performance characteristics 62
 - Pin assignment, device plug 25
 - Post-connection check (checklist) 27
 - Post-installation check 32
 - Post-installation check (checklist) 23
 - Potential equalization 62
 - Power consumption 62
 - Power supply failure 62
 - Pressure Equipment Directive 68
 - Pressure loss 65
 - Pressure tightness 65
 - Pressure-temperature ratings 65
 - Process conditions
 - Conductivity 65
 - Flow limit 65
 - Medium temperature 64

Pressure loss 65
 Pressure tightness 65
 Process connections 67
 Product safety 9

R

Reading measured values 42
 Recalibration 54
 Reference operating conditions 62
 Registered trademarks 7
 Remote operation 67
 Repair 55
 Repeatability 63
 Replacement
 Device 55
 Wear parts 55
 Replacing seals 54
 Requirements for personnel 8
 Return 55

S

Safety 8
 Sanitary compatibility 68
 Serial number 13
 Settings
 Device tag 33
 Pulse/frequency/switch output 34
 Resetting the totalizer 44
 Totalizer reset 44
 Shock resistance 64
 Signal on alarm 61
 Spare parts 55
 Standards and guidelines 69
 Sterilization in place (SIP) 64
 Storage conditions 15
 Storage temperature 15
 Storage temperature range 63
 structure
 Measuring device 11
 Submenu
 Administration 50
 Advanced setup 39
 Device information 51
 Events list 50
 Low flow cut off 39
 Output values 43
 Process variables 42
 Pulse/frequency/switch output 1 to n 34, 35, 37
 Sensor adjustment 40
 Simulation 41
 System units 33
 Totalizer 43
 Totalizer 1 to n 40
 Totalizer handling 44
 Supplementary documentation 69
 Supply unit
 Requirements 26
 Supply voltage 26, 62
 Surface roughness 67

System design
 Measuring system 59
 see Measuring device design
 System integration 31
 System pressure 19

T

Technical data, overview 59
 Temperature range
 Storage temperature 15
 Terminal assignment 24
 Tools
 For mounting 21
 Transport 15
 Transporting the measuring device 15
 Troubleshooting
 General 46

U

Use of the measuring device
 Borderline cases 8
 Incorrect use 8
 see Designated use

V

Vibration resistance 64
 Vibrations 19

W

W@M 54
 W@M Device Viewer 12, 55
 Weight
 SI units 66
 Transport (notes) 15
 US units 66
 Workplace safety 9

www.addresses.endress.com
