

Rosemount™ CX1100 In Situ Oxygen Transmitter



Essential instructions

Emerson™ designs, manufactures, and tests its products to meet many national and international standards. Because these instruments are sophisticated technical products, you must properly install, use, and maintain them to ensure they continue to operate within their normal specifications. The following instructions must be adhered to and integrated into your safety program when installing, using, and maintaining Emerson products.

- Read all instructions prior to installing, operating, and servicing the product.
- Install equipment as specified in the installation instructions of the appropriate instruction manual and per applicable local and national codes. Connect all products to the proper electrical and pressure sources.

Symbols



Earth (ground) terminal



Protective conductor terminal



Risk of electrical shock



Refer to reference manual.

Contents

Chapter 1	Install	1
	1.1 Probe installation	1
	1.2 Mount remote display	4
Chapter 2	Wire	8
	2.1 Installation specifications - interconnect cable	8
	2.2 Connect the cables	8
Chapter 3	Startup	13
Chapter 4	Calibration	14
	4.1 Procedure	14

Appendices and reference

Appendix A	Product certifications	16
	A.1 European Directive information	16
	A.2 Ordinary location certification	16
	A.3 Installing equipment in North America	16
	A.4 Rosemount CX1100 In-Situ Oxygen Transmitter	16
	A.4.1 North America	16

1 Install

⚠ WARNING!

Before installing this equipment, read the Essential Instructions at the front of this Quick Start Guide. Failure to follow safety instructions could result in serious injury or death.

1.1 Probe installation

A *weld plate* for welding to the flue gas duct can be supplied for new installations.

1. If using the standard square weld plate (*Figure 1-2*) or an optional flange mounting plate, weld or bolt the plate onto the duct.

The through hole diameter in the stack or duct wall and refractory material must be at least 2.5 in. (63.5 mm).

2. Insert probe through the opening in the mounting flange and bolt through the probe gasket and flange.

For horizontal installations, the breather port must be oriented such that it is facing downward.

Figure 1-1: Probe Installation

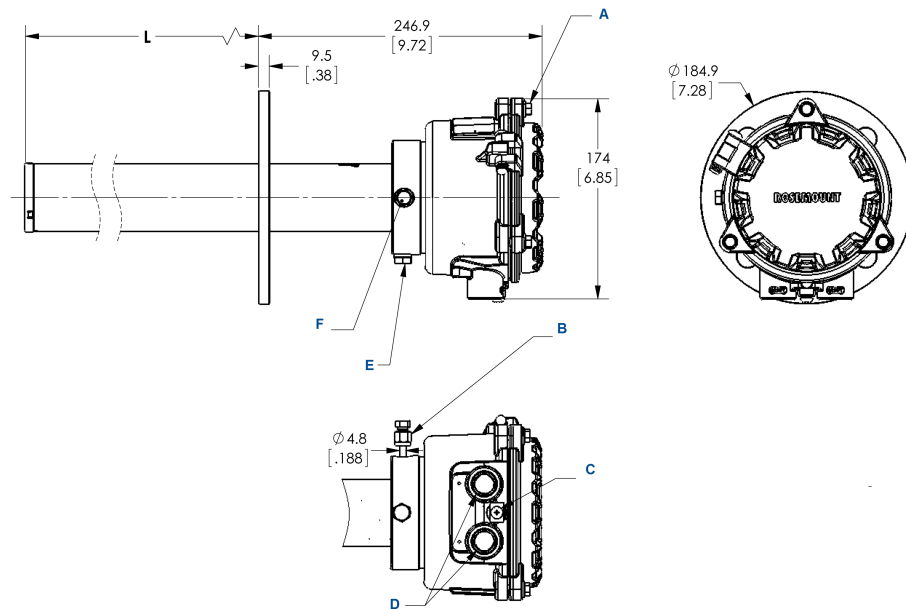

- A. M6 X 1 X 25 hex head machine screw (3X)
- B. Calibration gas, 3/16-in. tube fitting, 2.82 liter/min (10 SCFH), 138 kPa (20 psi)
- C. M5 X 0.8 x 10 pan head machine screw, ground screw
- D. 1/2 NPT conduit connection (power, signal)
- E. Breather port
- F. Calibration gas connection

NOTICE

All dimensions are in millimeters with inches in parentheses.

Table 1-1: Removal/Installation

Probe length	Removal envelope
.5 m (19.68 in.)	750 mm (30 in.)
1 m (39.37 in.)	1250 mm (49 in.)
2 m (78.74 in.)	2250 mm (89 in.)

Figure 1-2: Rosemount CX1100 Probe Installation

NOTICE

All dimensions are in millimeters with inches in parentheses.

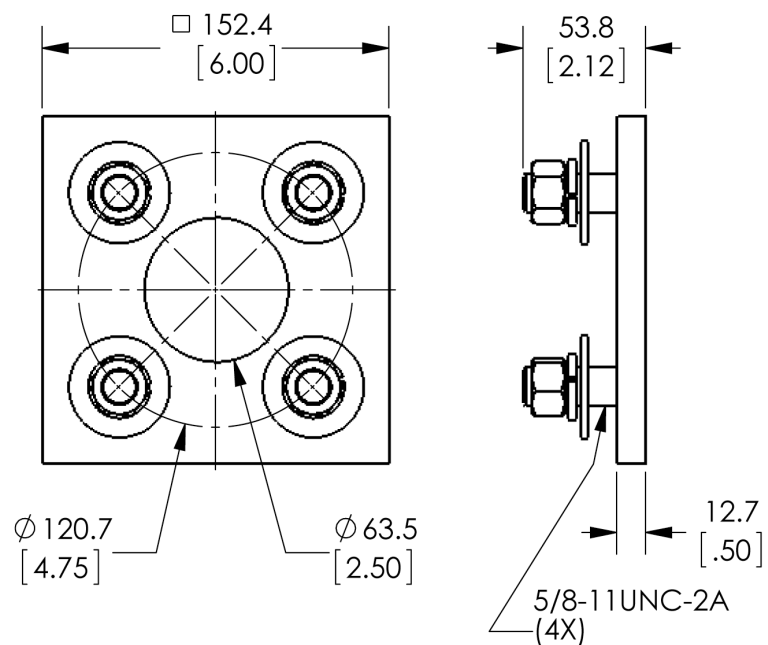
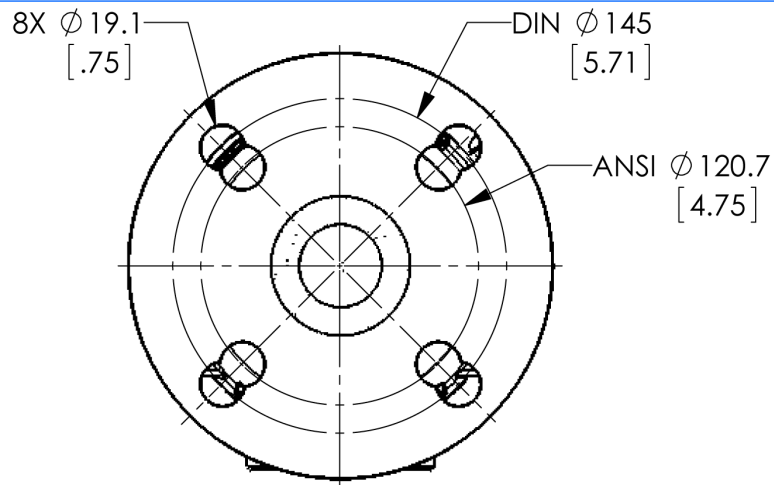

Square weld plate, ANSI pattern part 4512C34G01

Table 1-2: Mounting Flange

	ANSI	DIN
Flange dia		185 mm (7.28 in.)
Hold dia		19.1 mm (.75 in.)
4 holes eq sp on BC	120.7 mm (4.75 in.)	145 mm (5.71 in.)

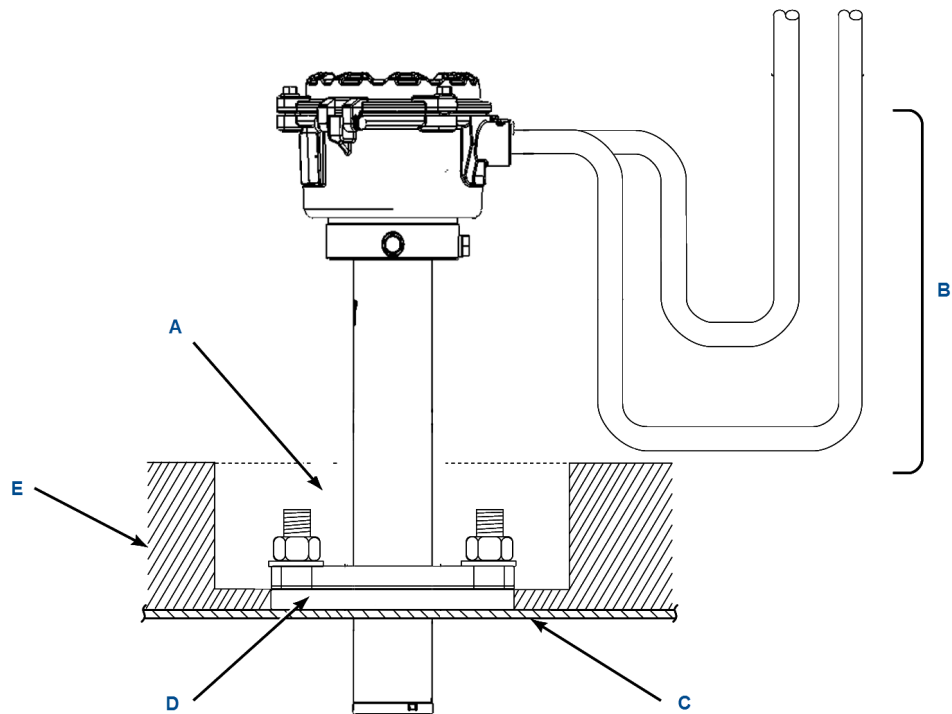
Figure 1-3: Drip loop and Insulation Removal

- A. **Note**
Replace insulation after installing CX1100.
- B. Drip loop
- C. Stack duct or metal wall
- D. Adapter plate
- E. Insulation

NOTICE

Probe installation may be vertical or horizontal.

1.2 Mount remote display

Complete the following steps to install the Rosemount CX1100 Remote Transmitter.

The Rosemount CX1100 Remote Transmitter is available in a panel mounting or wall/pipe mounting configuration. Refer to [Figure 1-4](#) or [Figure 1-5](#) for the panel, wall, or pipe mounting details. You need a wrench and bolts to mount the transmitter.

Procedure

1. Ensure all components are available to install the Rosemount CX1100 Remote Transmitter.
2. Select a mounting location near or removed from the Rosemount CX1100 Probe.

Consider the temperature limitations of the Rosemount CX1100 Remote Transmitter. Refer to product specifications when selecting the mounting location.
3. Mount at a height convenient for viewing and operating the interface.

Emerson recommends approximately 5 ft. (1.5 m).
4. The keypad window on the Rosemount CX1100 Remote Transmitter may have an exterior protective membrane. Remove the protective membrane prior to use of the Rosemount CX1100 Remote transmitter.

Failure to remove the protective membrane may cause the display to appear distorted. The membrane may become difficult or impossible to remove after extended use at elevated temperatures.

Figure 1-4: Wall/Surface and Pipe Mount

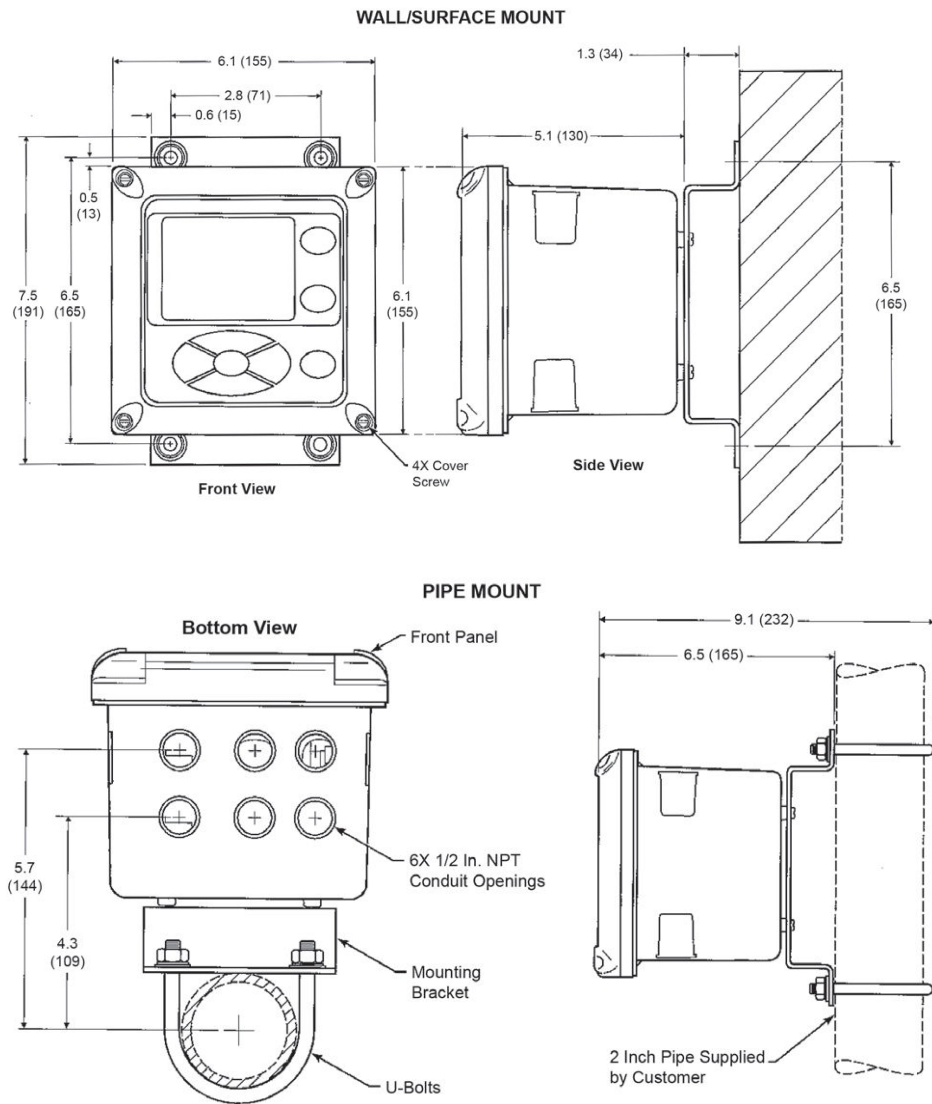
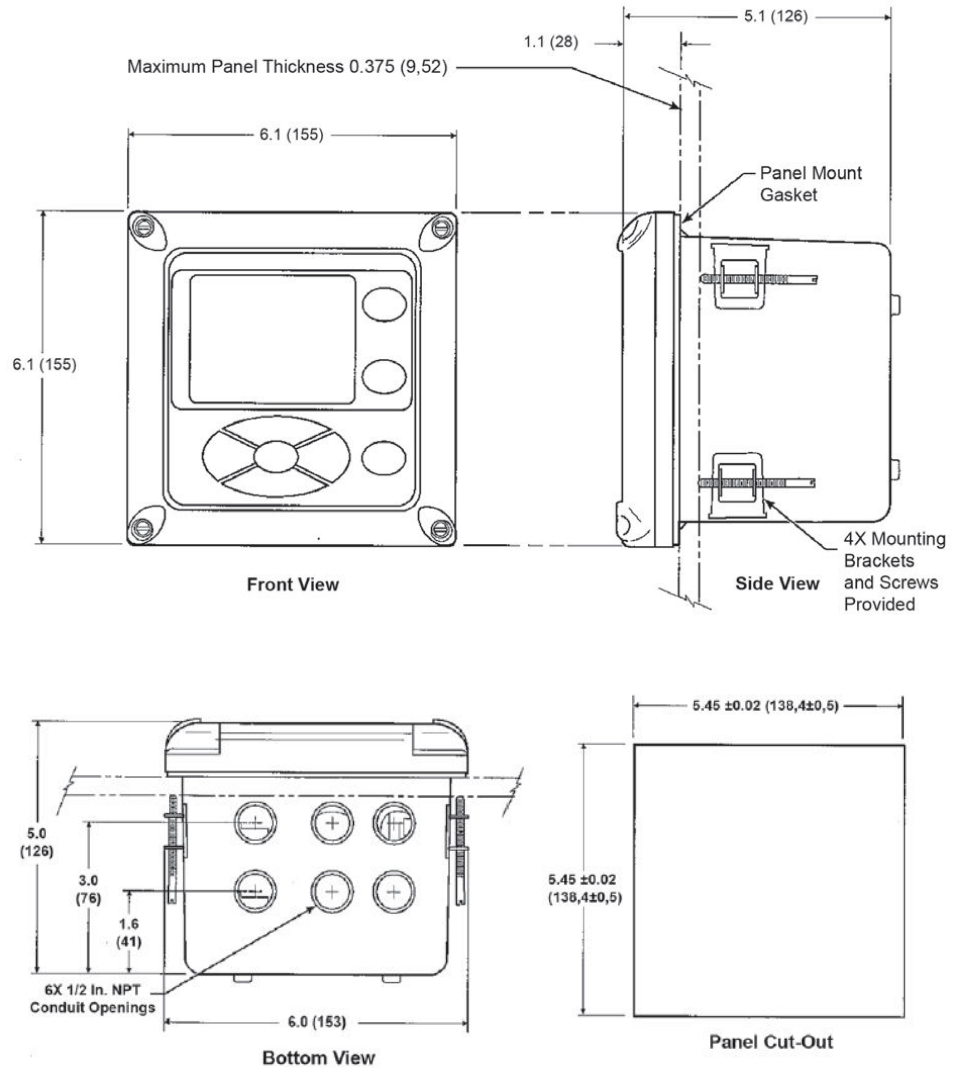

Figure 1-5: Panel Mount



2 Wire

All wiring must conform to local and national codes.

⚠ WARNING!

Before installing the equipment, read the Safety Instructions at the front of this manual. Failure to follow safety instructions could result in serious injury or death.

NOTICE

To maintain proper earth grounding, ensure a positive connection exists between the probe terminations housing and earth. The connecting wire must be 14 AWG minimum.

NOTICE

Line voltage, signal, and relay wiring must be rated for at least 221 °F (105 °C).

NOTICE

If metal conduit is used with the Rosemount™ CX1100 Remote Transmitter, reliably bond the conduit to protective earth. The grounding plate inside the Rosemount CX1100 Remote Transmitter is not bonded to PE and does not provide adequate grounding.

2.1 Installation specifications - interconnect cable

Customer supplied cable up to 200 ft. (60 m) long, rated for -40 to 194 °F (-40 to 90 °C) and voltage 300 VACrms.

Heater power: 3 multi conductor 18ga shielded cable to connect the heater control signal

Probe sensing: 3 twisted pair conductors 22ga overall shielded cable to connect the TC, O₂, and CJC signals.

Cable may be purchased as two separate cables.

2.2 Connect the cables

Raw voltages from the oxygen sensor and heater thermocouple are transmitted from the Rosemount CX1100 Probe to the Rosemount CX1100 Remote Transmitter. The remote transmitter also controls power to the probe heater in order to maintain the correct sensor temperature.

This arrangement calls for interconnect wiring consisting of nine conductors. Given the recommended wire specifications, the maximum length for this cable is 200 ft (60 m) (refer to [Section 2.1](#)).

NOTICE

To maintain EMC/EMI noise protection, connect the customer supplied 9 conductor cable and cable glands properly to ground.

Procedure

1. Run the signal and power cables between the probe and the installation site for the optional Rosemount CX1100 Remote Transmitter.
2. Remove the covers from the probe and the remote transmitter (if applicable).
3. Feed all probe wiring through the conduit port of the probe.
4. Refer to [Figure 2-2](#). Connect probe heater power leads to probe connector.
5. Connect O2 signal, thermocouple, and cold junction (CJC) wires from probe to the Rosemount CX1100 Remote Transmitter.
6. At the Rosemount CX1100 Remote Transmitter, connect the cable leads to the connectors on the sensor board as indicated in [Figure 2-1](#).

Figure 2-1: Wiring Diagram

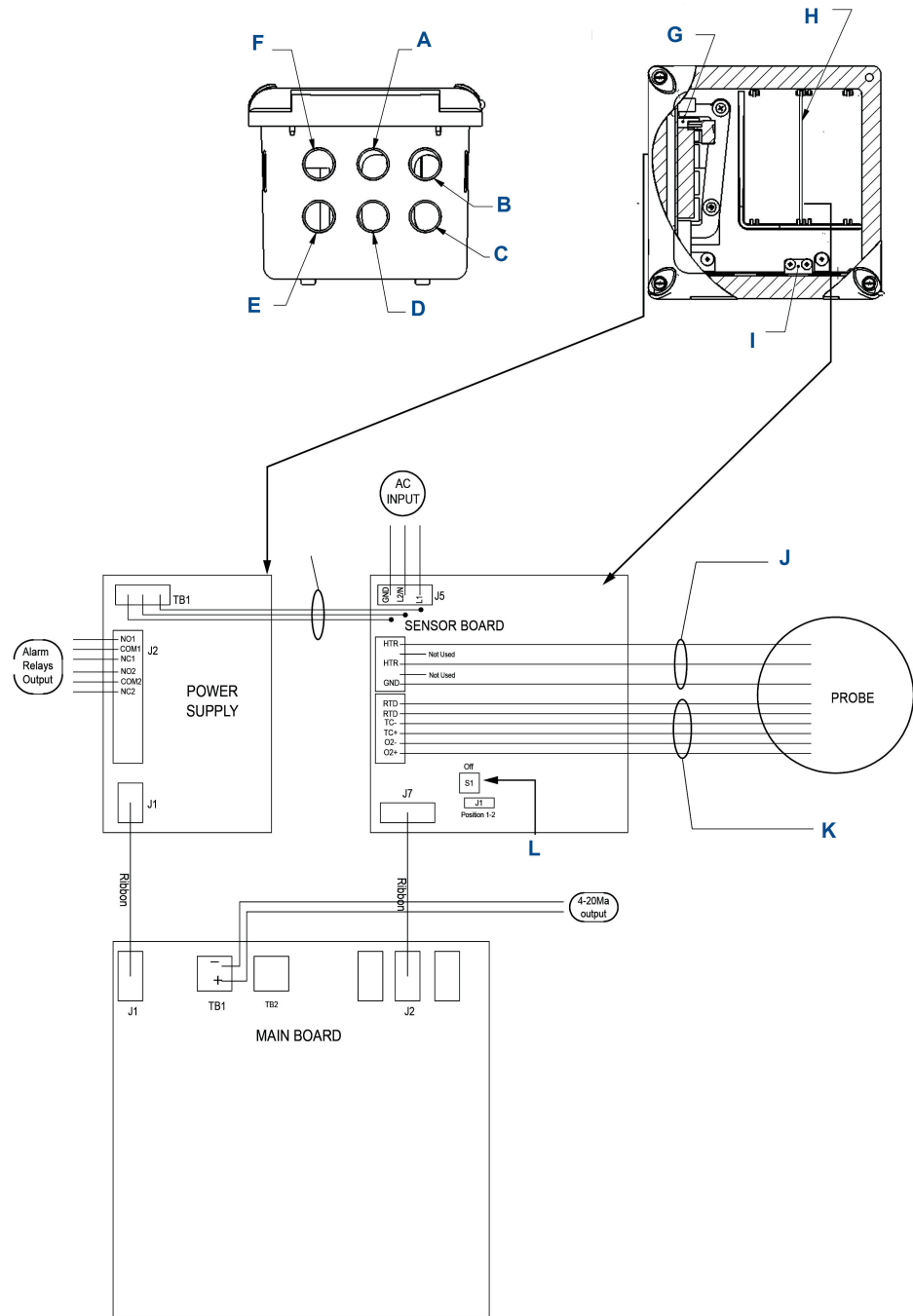

- A. Heater power to probe
- B. Alternate 4-20 mA out
- C. Signal from probe
- D. Power to remote transmitter
- E. Alarm relay

- F. 4-20 mA out
- G. Power supply
- H. Combustion sensor
- I. Shield ground
- J. Heater power terminates to underside of the sensor board.
- K. Probe sensing connect shield to GND
- L. S1 Dip switch is for factory use only and should be in the Off position.

AC power wires from power supply board to the underside of the sensor board are provided with the sensor board.

Figure 2-2: Closeup Wiring Diagram

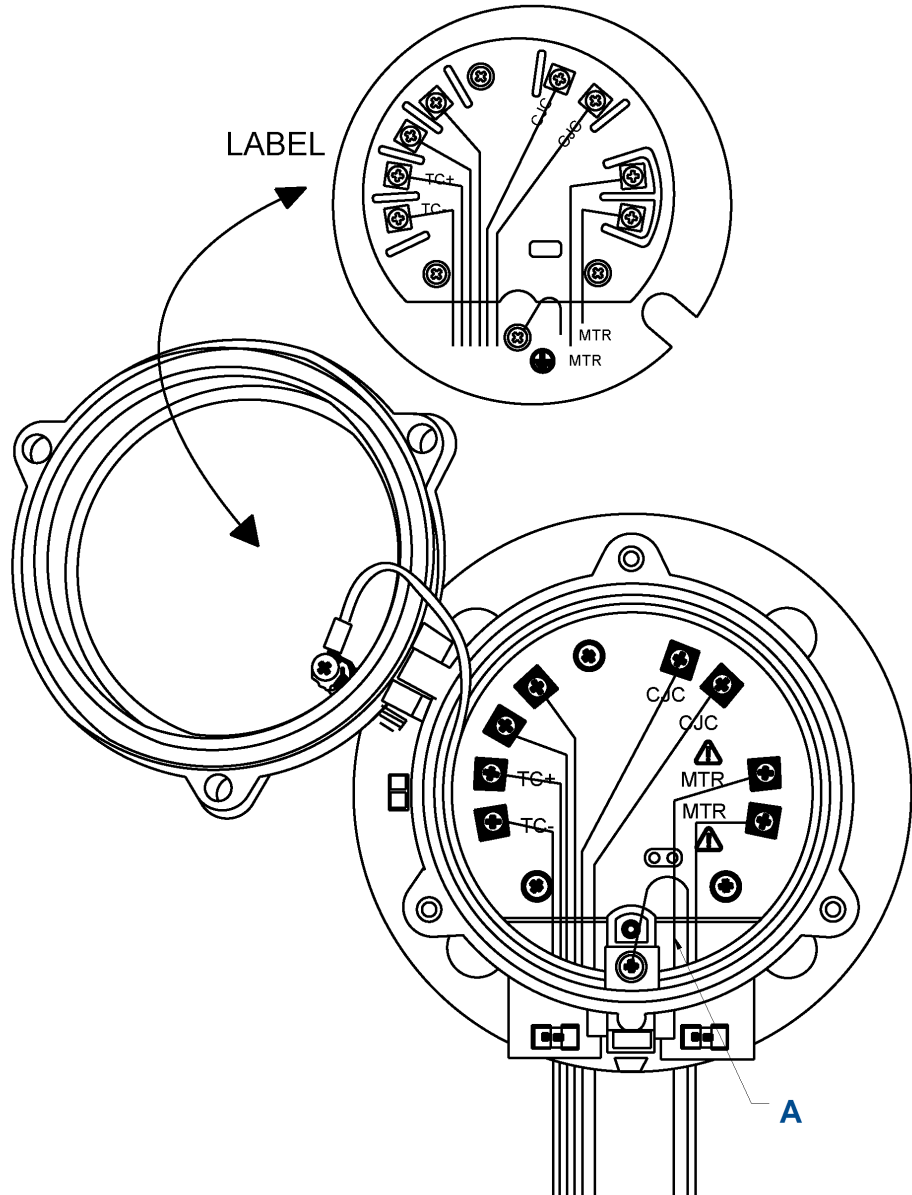

A. M4 X 0.7 X 8 pan head screw machine screw (internal ground)

3 Startup

1. Apply AC line power to the Rosemount™ CX1100 Remote Transmitter.

The probe takes approximately 45 minutes to warm up to the 1357 °F (736 °C) setpoint. The 4-20 mA signal remains at a default value of 3.5 mA, and the O₂ reading remains at 0% through the warmup period.

2. After warmup, the probe begins reading oxygen, and the 4-20 mA output is based on the default range of 0-10% O₂.

If there is an error condition at startup, an alarm message is displayed on the Rosemount CX1100 Remote Transmitter.

4 Calibration

The Rosemount™ CX1100 In Situ Oxygen Transmitter can be calibrated in the installed position without removing the instrument from the process duct and also while the combustion process is online. Gas is applied to the sensor through the calibration gas fitting. New Rosemount CX1100 In Situ Oxygen Transmitter systems are factory calibrated and are generally acceptable for initial startup and operation. High accuracy can be gained by calibrating a system during normal operating conditions. Emerson™ recommends calibrating on a semi-annual to annual basis for most applications; however actual calibration frequency may vary per process unit.

Calibrations are conducted using a two point calibration. Factory calibration uses 0.4% O₂ and 8.0% O₂ gases with a balance of nitrogen and is therefore recommended. Calibration gases with other oxygen concentrations are acceptable. If using different calibration gas values, additional configuration through the Rosemount CX1100 Remote Transmitter is required. Emerson does not recommend pure nitrogen as a calibration gas. Use a two-stage pressure regulator to establish a pressure of 20 psi from the bottles and set the flowmeter to 5 scfh (2.5 L/min) flow rate.

4.1 Procedure

The calibration of the Rosemount CX1100 Probe is initiated from the Rosemount CX1100 Remote Transmitter. The Rosemount CX1100 Remote Transmitter display prompts you with the calibration instructions.

1. Press the **x1** or **x2** menu button on the Rosemount CX1100 Remote Transmitter display to enter the probe.
2. Navigate, using **Up** and **Down** buttons to `Setup`; press **Enter**.
3. Navigate to `Cal Gas values`; press **Enter**.
4. Navigate to `Cal Gas 1` and press **Enter** twice to highlight the value setting.
5. Use the **Up** and **Down** buttons to set `Cal Gas 1` value and **Left** and **Right** buttons to move to decimals setting.
6. After setting the correct value, press **Enter** and press **Left** to go to the Calibration Setup for `Cal Gas 2`, `Gas time`, and `Purge time` settings.
7. After setting the values (0.4% O₂, 8.0% O₂, and 300s are the defaults), press **Left** to go up to the **Calibration** submenu.
8. Navigate using the **Up** and **Down** buttons to `Calibration` and press **Enter** to start.
9. Follow the instructions on the display, manually applying calibration gases (0.4% and 8.0% O₂ at 5 SCFH are recommended) to the calibration port.
10. After the calibration is finished, press **Left** and use the **Up** and **Down** buttons the check the current and previous 10 calibrations log.

After completing the procedure, the Rosemount CX1100 software calculates new calibration values and determines whether they meet an acceptance criteria. If successful, the new calibration values automatically replace the previous values. In the event the calibration values do not meet the accepted performance criteria, the existing calibration values remain in effect, and Emerson recommends replacing the Rosemount CX1100 Probe.

⚠ CAUTION!

EQUIPMENT DAMAGE

Make sure that the calibration gas cap is replaced tightly after calibration is complete. Many combustion processes operate at a slight negative pressure (draft pressure) and can draw ambient air down the cal gas lines and into the sensing cell, causing a false elevated oxygen reading. The same phenomenon is possible if the calibration gas hoses become degraded or loose.

Appendix A

Product certifications

A.1 European Directive information

A copy of the EC Declaration of Conformity can be found at the end of the Quick Start Guide. The most recent revision of the EC Declaration of Conformity can be found at Emerson.com/Rosemount.

A.2 Ordinary location certification

As standard, the transmitter has been examined and tested to determine that the design meets the basic electrical, mechanical, and fire protection requirements by a nationally recognized test laboratory (NRTL) as accredited by the Federal Occupational Safety and Health Administration (OSHA).

A.3 Installing equipment in North America

The US National Electrical Code (NEC) and the Canadian Electrical Code (CEC) permit the use of Division marked equipment in Zones and Zone marked equipment in Divisions. The marking must be suitable for the area classification, gas, and temperature class. This information is clearly defined in the respective codes.

A.4 Rosemount CX1100 In-Situ Oxygen Transmitter

A.4.1 North America

CSA

Certificate: 70172073

Standards: CAN/CSA C22.2 No. 61010-1-12, CAN/CSA C22.2 No. 61010-2-010:15, UL 61010-1 (3rd Edition), UL 61010-2-10 (3rd Edition), UL 50E (2012), C22.2 No. 94.2-07, IEC 60529:2013 (Edition 2.2)

Markings: Type 4X, IP66



Condition of acceptability:

1. The measuring of net O₂ range is limited 0-23%.
2. The equipment shall be installed in accordance with manufacturer's specification by qualified personnel.
3. This equipment is for permanently connection to power source with approved power cord at end installation in accordance with local codes.
4. The Probe unit of the equipment shall be connected to PE separately at end installation.
5. End installation to provide the means of disconnection from power sources.
6. End installation to comply with the requirement of IP66 and 4X.



EU Declaration of Conformity

No: RAD1116 Rev. A



We,

Rosemount Inc.
8200 Market Boulevard
Chanhassen, MN 55317-9685
USA

declare under our sole responsibility that the product,

Rosemount™ Oxygen Analyzer, Model CX1100

manufactured by,

Rosemount Inc.
8200 Market Boulevard
Chanhassen, MN 55317-9685
USA

to which this declaration relates, is in conformity with the provisions of the European Union Directives, including the latest amendments, as shown here. Assumption of conformity is based on the application of the harmonized standards and, when applicable or required, a European Union notified body certification.

EMC Directive (2014/30/EU)

Harmonized Standards: EN 61326-1:2013

Low Voltage Directive (2014/35/EU)

Harmonized Standards: EN 61010-1:2010

PED Directive (2014/68/EU)

Sound Engineering Practice

(signature)

Chris LaPoint

(name)

Vice President of Global Quality

(function)

7-Mar-18; Shakopee, MN USA

(date of issue & place)

GLOBAL HEADQUARTERS

Emerson Automation Solutions
6021 Innovation Blvd
Shakopee, MN 55379, USA

📞 +1 800 999 9307 or +1 952 906 8888

📠 +1 952 949 7001

✉ gas.csc@emerson.com

NORTH AMERICA

Rosemount
8200 Market Boulevard
Chanhassen, MN 55317

📞 +1 800 999 9307

📠 +1 952 949 7001

✉ gas.csc@emerson.com

EUROPE

Emerson Automation Solutions
Neuhofstrasse 19a P.O. Box 1046
CH-6340 Baar
Switzerland

📞 + 41 (0) 41 768 6111

📠 + 41 (0) 41 768 6300

✉ gas.csc@emerson.com

MIDDLE EAST AND AFRICA

Emerson Automation Solutions
Emerson FZE
Jebel Ali Free Zone
Dubai, United Arab Emirates, P.O. Box 17033

📞 +971 4 811 8100

📠 +971 4 886 5465

✉ gas.csc@emerson.com

ASIA-PACIFIC

Emerson Automation Solutions
1 Pandan Crescent
Singapore 128461
Singapore

📞 +65 777 8211

📠 +65 777 0947

✉ gas.csc@emerson.com

 [Linkedin.com/company/Emerson-Automation-Solutions](https://www.linkedin.com/company/Emerson-Automation-Solutions)

 twitter.com/rosemount_news

 [Facebook.com/Rosemount](https://www.facebook.com/Rosemount)

 [youtube.com/RosemountMeasurement](https://www.youtube.com/RosemountMeasurement)

 [google.com/+RosemountMeasurement](https://plus.google.com/+RosemountMeasurement)

 [AnalyticExpert.com](https://www.analyticexpert.com)

©2018 Emerson. All rights reserved.

The Emerson logo is a trademark and service mark of Emerson Electric Co. Rosemount is a mark of one of the Emerson family of companies. All other marks are the property of their respective owners.