

Rosemount™ CX1100 In-Situ Oxygen Transmitter



Essential instructions

Read this page before proceeding!

Emerson™ designs, manufactures, and tests its products to meet many national and international standards. Because these instruments are sophisticated technical products, you must properly install, use, and maintain them to ensure they continue to operate within their normal specifications. The following instructions must be adhered to and integrated into your safety program when installing, using, and maintaining Emerson products. Failure to comply with instructions may result in: loss of life, personal injury, property damage, damage to this instrument, and warranty invalidation.

- Read all instructions prior to installing, operating, and servicing the product.
- If you do not understand any of the instructions, contact your Emerson representative for clarification.
- Follow all warnings, cautions, and instructions marked on and supplied with the product, including this manual.
- To ensure proper performance, use only informed and qualified personnel to install, operate, update, program, and maintain the product.
- Install equipment as specified in the installation instructions of the appropriate instruction manual and per applicable local and national codes. Connect all products to the proper electrical and pressure sources.
- Use only factory documented components for repair. Tampering and unauthorized substitution and parts can affect product performance and cause unsafe operation of your process.

WARNING!

RISK OF ELECTRICAL SHOCK

1. **Disconnect the main power wire from the separate power source before servicing.**
2. **Do not operate or energize instrument with case open!**
3. **Wiring connected in this box must be rated at least 240 Vac and 14 gauge.**
4. **Non-metallic cable strain reliefs do not provide grounding between conduit connections! Use grounding type bushings and jumper wires.**
5. **Seal unused cable conduit entries securely with non-flammable enclosures to provide transmitter's enclosure integrity in compliance with personal safety and environmental protection requirements. Seal unused conduit openings with Type 4X or IP66 conduit plugs to maintain the ingress protection rating (Type 4X) of transmitter's enclosure.**
6. **Operate only with front panel fastened and in place.**
7. **For safety and performance, connect and properly ground the system through a three wire power source.**
8. **Proper use and configuration is your responsibility.**
9. **Install all protective equipment covers and safety ground leads after installation. Failure to install covers and ground leads could result in serious injury or death.**
10. **Provide local ground connection to the Rosemount™ CX1100 in order to avoid electric shock. The ground conductor should be equal to or greater than 16 AWG for a copper conductor in free air or 12 AWG for an enclosed copper conductor.**
11. **Disconnect and lock out power before connecting the power supply.**
12. **Install all protective covers and safety ground leads after installation. Failure to install covers and ground leads could result in serious injury or death.**
13. **Disconnect and lock out power before working on any electrical components. There is voltage up to 240 Vac. Verify the reliability and continuity of the grounding of the probe connection before powering the equipment.**
14. **To meet the Safety Requirements of IEC 61010-1 (EC requirement) and ensure safe operation of the equipment, make a connection to the main electrical power supply through a circuit breaker (max 10A) which will disconnect all current-carrying conductors during a fault situation. The circuit breaker should also include a mechanically operated isolating switch. If it does not, then locate another means of disconnecting the supply from the equipment close by. Circuit breakers or switches must comply with a recognized standard, such as IEC 60947.**
15. **Ensure that all equipment doors are closed and protective covers are in place, except when maintenance is being performed by qualified people, to prevent electrical shock and personal injury.**

CAUTION!

- **If the ducts will be washed down during outage, make sure to power down the probes and remove them from the wash area.**
- **When replacement parts are required, ensure that qualified people use replacement parts specified by Emerson. Unauthorized parts and procedures can affect the product's performance, place the safe operation of your product at risk, and void your warranty. Look-alike substitutions may result in fire, electrical hazards, or improper operation.**

NOTICE

The information contained in this document is subject to change without notice.

Symbols used on equipment and in instruction manual



Earth (ground) terminal



Protective conductor terminal



Risk of electrical shock



Hot surface



Refer to reference manual.



Equipment protected throughout by double insulation
(applies to Rosemount CX1100 Remote Transmitter housing only)

NOTICE

If the equipment is used in a manner not specified by the manufacturer, the protection provided by the equipment may be impaired.

Contents

Chapter 1	General information	1
1.1	Overview	1
1.2	Rosemount CX1100 Oxygen Probe and Transmitter	1
1.3	Typical system package	2
1.4	Rosemount CX1100 In-Situ Oxygen Transmitter ordering information	3
1.5	Specifications	4
Chapter 2	Install	7
2.1	Probe installation	7
2.2	Mount remote display	10
Chapter 3	Wire	15
3.1	Installation specifications - interconnect cable	15
3.2	Connect the cables	15
Chapter 4	Startup	21
Chapter 5	Calibration and maintenance	23
5.1	Procedure	23
5.2	Calibration record	25
Chapter 6	Rosemount™ CX1100 In Situ Oxygen Transmitter menu trees	27
6.1	System menu tree	27
6.2	Probe menu tree	28
Chapter 7	Parameters	31
7.1	System and probe parameters	31
7.2	Rosemount™ CX1100 In Situ Oxygen Transmitter system alarms	34

Appendices and reference

Appendix A	Rosemount™ CX1100 product certifications	37
A.1	European Directive information	37
A.2	Ordinary location certification	37
A.3	Installing equipment in North America	37
A.4	Rosemount CX1100 In-Situ Oxygen Transmitter	37
A.4.1	North America	37

1 General information

1.1 Overview

The Rosemount™ CX1100 In Situ Oxygen Transmitter provides a continuous, accurate measurement of the oxygen remaining in flue gases coming from a combustion process. Accurate measurements of furnace exhaust excess oxygen are critical for combustion optimization, which result in reduced energy costs, increased safety, and lower emissions. This product is intended for use for combustion applications only.

The Rosemount CX1100 probe contains a zirconia type oxygen sensor. At high temperatures, zirconia produces an electrical potential that is proportional to the difference in process oxygen concentration and ambient reference air. This voltage is transmitted to the Rosemount CX1100 remote transmitter and output as an analog signal. The sensor is mounted at the end of the probe tube which extends into a flue gas duct or stack. Varying lengths of the probe are available to achieve desired insertion depths. The probe tube also houses a heating element to precisely control the temperature of the sensor, reducing errors induced by varying process temperatures.

1.2 Rosemount CX1100 Oxygen Probe and Transmitter

A complete Rosemount CX1100 In Situ Oxygen Transmitter system includes a probe and remote transmitter. Raw signals (sourced from the heater thermocouple and oxygen sensor) and power are transmitted between the Rosemount CX1100 probe and the Rosemount CX1000 remote transmitter, interconnect wiring consisting of nine conductors. The specifications of the wiring arrangement can be found in [Chapter 3](#). If following the specifications, 200 ft (61 m) is the maximum cable length allowed.

1.3 Typical system package

Figure 1-1: Typical System Package

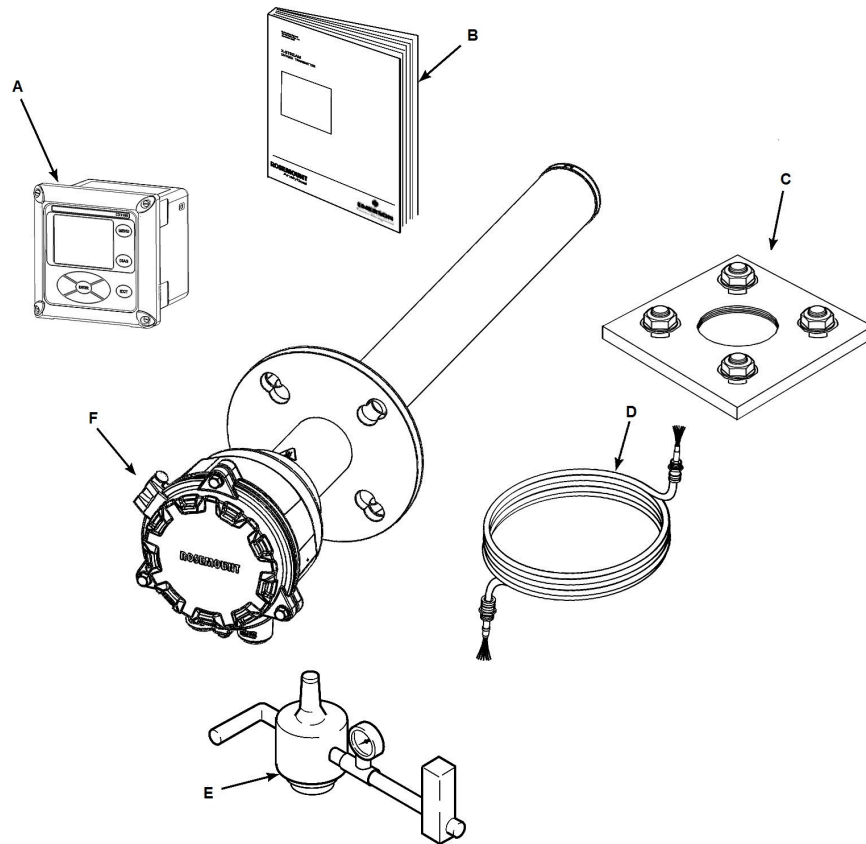

- A. *Rosemount CX1100 Remote Transmitter*
 - B. *Quick Start Guide*
 - C. *Optional mounting or adapter plate*
 - D. *Interconnect cable (user-supplied)*
 - E. *Optional calibration gas flowmeter*
 - F. *Rosemount CX1100 Probe*
-

1.4 Rosemount CX1100 In-Situ Oxygen Transmitter ordering information

Model	Product description
CX1100	In Situ Oxygen Transmitter
Material	
A	304L stainless steel
Probe length	
050	1.64 ft. (0.5 m) oxygen probe
100	3.28 ft. (1.0 m) oxygen probe
200	6.56 ft. (2.0 m) oxygen probe
Probe mounting flange	
F20	ANSI/DIN: 4.75 in. / 5.71 in. bolt circle, 0.75 in. holes
Transmitter	
M7	Remote transmitter with LCD display and interface
M0	Probe only (no transmitter)
Product certification	
G6	CSA ordinary location
Probe mounting hardware	
N1	New installation plate - ANSI pattern
N2	New installation plate - DIN pattern
Transmitter mounting hardware	
T2	Panel mount kit with gasket
T3	2-in. pipe / wall mount kit
Calibration accessories	
F1	Calibration gas flowmeter

1.5 Specifications

Table 1-1: System Measurement Specifications

Specification	Description
Net O ₂ range	0 - 23%
Repeatability	0.1% of O ₂ or 1.0% of reading, whichever is lower
Lowest detectable limit	0.05% O ₂
Process temperature effect	Less than 0.3% O ₂ from 77 to 1292 °F (25 to 700 °C)
System speed of response to calibration gas	Initial response in less than 3 seconds, T90 in 10 seconds. Response to process gas changes will vary depending on process gas velocity and particulate loading of the diffuser.

Environmental specifications

Table 1-2: Probe

Specification	Description
Probe	Process wetted materials are 304 stainless steel.
Maximum process temperature	752 °F (400 °C)

Table 1-3: Probe Terminations

Specification	Description
Rosemount CX1100 probe ambient temperature limits	-4 to 158 °F (-20 to 70 °C)

Table 1-4: Remote Display

Specification	Description
Materials	Polycarbonate
Ambient temperature limits	-4 to 122 °F (-20 to 50 °C)

Installation specifications

Table 1-5: Probe

Specification	Description
Probe mounting range	Vertical or horizontal: 2-in. 150# (4.75 in. (121 mm) bolt circle) and DIN145 Note Flanges are flat-faced and for mounting only. Flanges are not pressure-rated. A 2.5-in. diameter hole in the process is required. Many adapter flanges are available to mate to existing flanges.
Reference air	No instrument air required. Ambient air diffuses into the probe passively. Ensure that ambient air is fresh (20.95% O ₂).
Calibration	Semi-automatic manual gas switching. New calibration values are calculated in the remote electronics.
Cal gases	0.4% and 8% O ₂ , balance N ₂ recommended. Instrument air may be used as a high cal gas, but is not recommended. 100% nitrogen cannot be used as a low cal gas.
Calibration gas flow	5 scfh (2.5 l/min) at 15 PSI
Heater electrical power	120/240 Vac, 50/60 Hz, 1.8 A Max
Traditional architecture cable	Customer-supplied
Power consumption of probe heater	150 watts max. during initial warm-up

Table 1-6: Remote Electronics

Specification	Description
Electrical power	120/240 Vac, 50/60 Hz, 1.8 A Max
Power consumption	150 watts during initial warm-up
Analog output	4-20 mA. Max load 550 Ohms
Alarms relays	Two SPDT Form C, epoxy sealed contacts rated 5A, 30 Vdc, 120 Vac, or 230 Vac; user configurable to alarm. Resistive load: 5A at 28 Vdc or 300 Vac Inductive load: 1/8 HP at 120/240 Vac
Probe sensing cable	3 twisted pair conductors, 22 ga overall shielded cable to connect the TC, O ₂ , and CJC signals
Heater cable	3 multi conductor 18 ga shielded cable to connect the heater control signal

Rosemount CX1100 Probe	Shipping weight	Actual weight
19.68 in. (0.5 m)	19 lb. (8.6 kg)	13.5 lb. (6.1 kg)
39.37 in. (1 m)	23 lb. (10.43 kg)	16.8 lb. (7.6 kg)
78.74 in. (2 m)	30.5 lb. (13.8 kg)	23 lb. (10.43 kg)

Rosemount CX1100 Remote Transmitter dimensions in inches (millimeters)	Shipping weight	Actual weight	Part number
6.10 x 6.10 x 5.15 in. (155 x 155 x 131 mm)	4 lb. (1.8 kg)	3 lb. (1.4 kg)	24490-00

Accessory	Part number
Calibration flowmeter	771B635H01
Cal gas adaptor kit to mate to existing tubing arrangement	1A98771H07

2 Install

⚠ WARNING!

ELECTRIC SHOCK

Install all protective equipment covers and safety ground leads after installation. Failure to install covers and ground leads could result in serious injury or death.

⚠ CAUTION!

EQUIPMENT DAMAGE

Do not allow the temperature of the Rosemount™ CX1100 Probe electronics to exceed 194 °F (90 °C) or damage to the unit may result.

2.1 Probe installation

A *weld plate* for welding to the flue gas duct can be supplied for new installations.

1. If using the standard square weld plate ([Figure 2-2](#)) or an optional flange mounting plate, weld or bolt the plate onto the duct.

The through hole diameter in the stack or duct wall and refractory material must be at least 2.5 in. (63.5 mm).

2. Insert probe through the opening in the mounting flange and bolt through the probe gasket and flange.

For horizontal installations, the breather port must be oriented such that it is facing downward.

Figure 2-1: Probe Installation

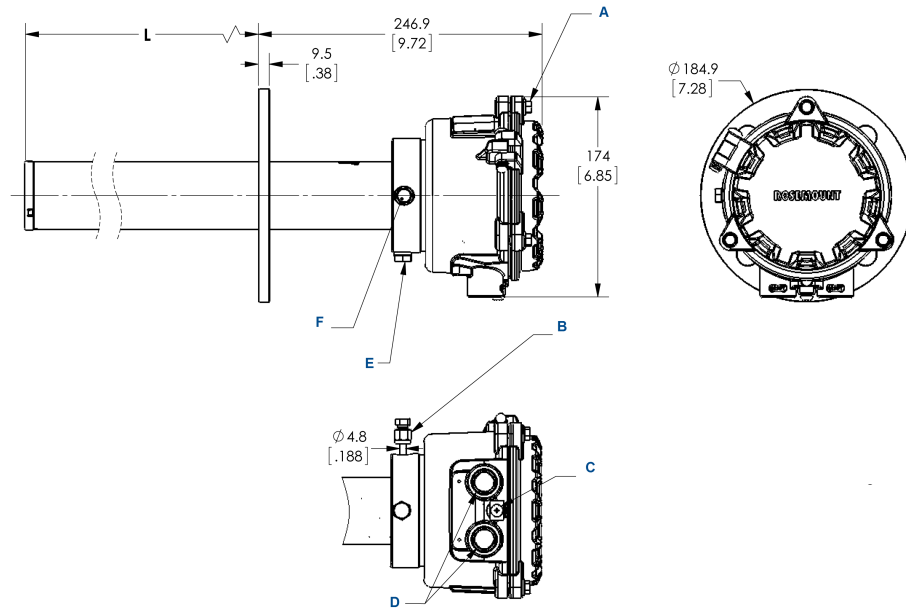

- A. M6 X 1 X 25 hex head machine screw (3X)
- B. Calibration gas, 3/16-in. tube fitting, 2.82 liter/min (10 SCFH), 138 kPa (20 psi)
- C. M5 X 0.8 x 10 pan head machine screw, ground screw
- D. 1/2 NPT conduit connection (power, signal)
- E. Breather port
- F. Calibration gas connection

NOTICE

All dimensions are in millimeters with inches in parentheses.

Table 2-1: Removal/Installation

Probe length	Removal envelope
.5 m (19.68 in.)	750 mm (30 in.)
1 m (39.37 in.)	1250 mm (49 in.)
2 m (78.74 in.)	2250 mm (89 in.)

Figure 2-2: Rosemount CX1100 Probe Installation

NOTICE

All dimensions are in millimeters with inches in parentheses.

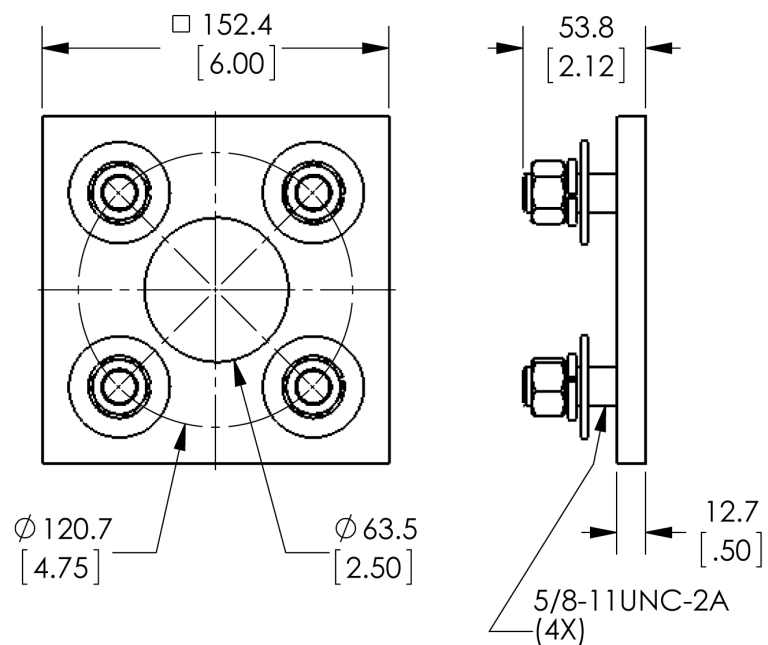
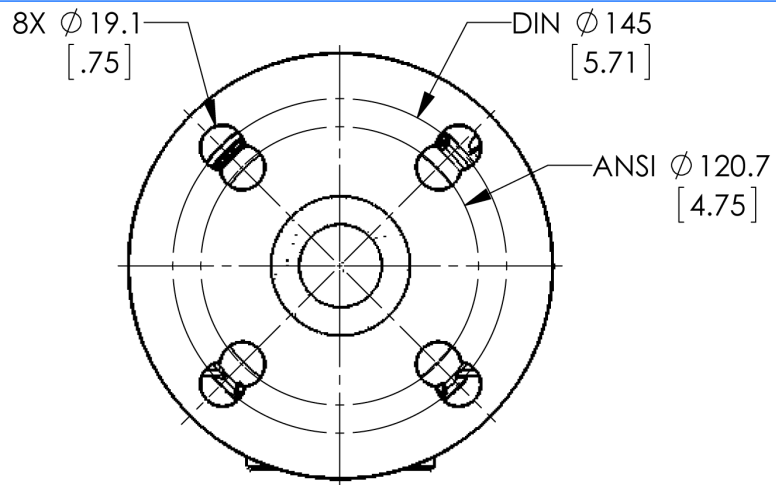

Square weld plate, ANSI pattern part 4512C34G01

Table 2-2: Mounting Flange

	ANSI	DIN
Flange dia		185 mm (7.28 in.)
Hold dia		19.1 mm (.75 in.)
4 holes eq sp on BC	120.7 mm (4.75 in.)	145 mm (5.71 in.)

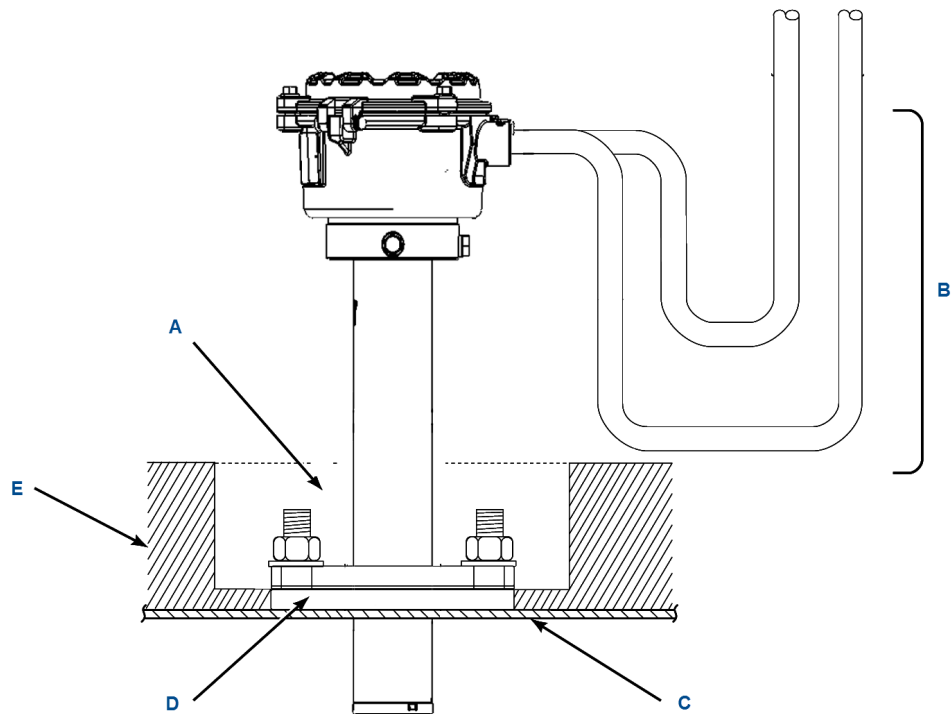
Figure 2-3: Drip loop and Insulation Removal

- A. **Note**
Replace insulation after installing CX1100.
- B. Drip loop
- C. Stack duct or metal wall
- D. Adapter plate
- E. Insulation

NOTICE

Probe installation may be vertical or horizontal.

2.2 Mount remote display

Complete the following steps to install the Rosemount CX1100 Remote Transmitter.

The Rosemount CX1100 Remote Transmitter is available in a panel mounting or wall/pipe mounting configuration. Refer to [Figure 2-4](#) or [Figure 2-5](#) for the panel, wall, or pipe mounting details. You need a wrench and bolts to mount the transmitter.

Procedure

1. Ensure all components are available to install the Rosemount CX1100 Remote Transmitter.
2. Select a mounting location near or removed from the Rosemount CX1100 Probe.

Consider the temperature limitations of the Rosemount CX1100 Remote Transmitter. Refer to product specifications when selecting the mounting location.
3. Mount at a height convenient for viewing and operating the interface.

Emerson recommends approximately 5 ft. (1.5 m).
4. The keypad window on the Rosemount CX1100 Remote Transmitter may have an exterior protective membrane. Remove the protective membrane prior to use of the Rosemount CX1100 Remote transmitter.

Failure to remove the protective membrane may cause the display to appear distorted. The membrane may become difficult or impossible to remove after extended use at elevated temperatures.

Figure 2-4: Wall/Surface and Pipe Mount

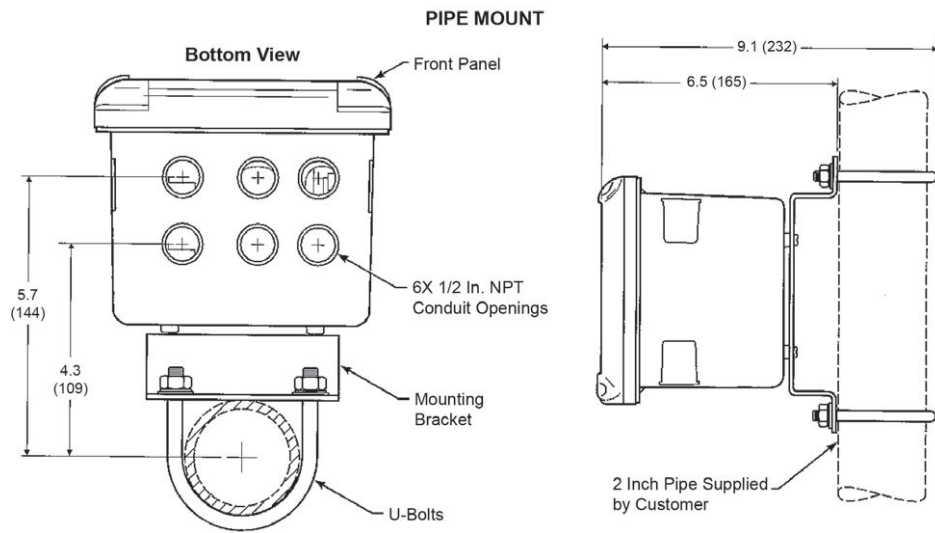
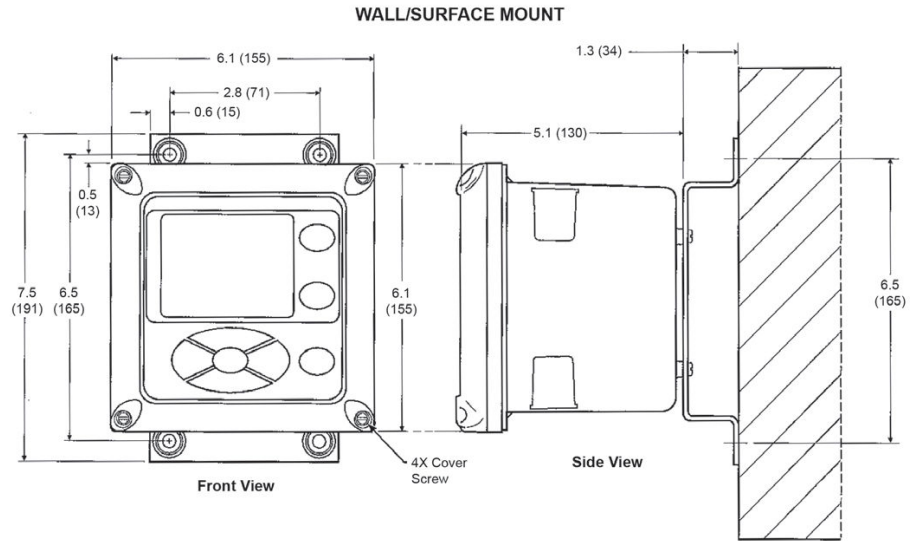
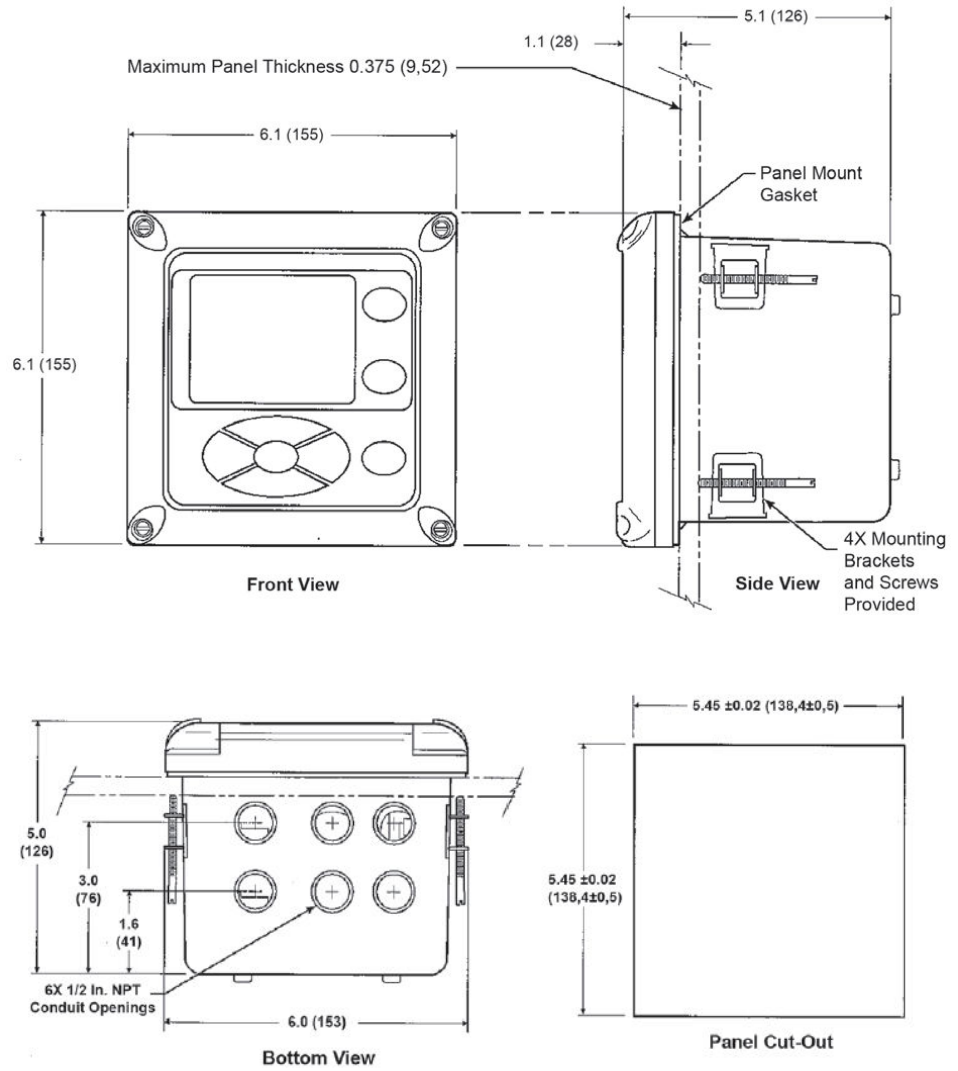

Figure 2-5: Panel Mount



3 Wire

All wiring must conform to local and national codes.

⚠ WARNING!

Before installing the equipment, read the Safety Instructions at the front of this manual. Failure to follow safety instructions could result in serious injury or death.

NOTICE

To maintain proper earth grounding, ensure a positive connection exists between the probe terminations housing and earth. The connecting wire must be 14 AWG minimum.

NOTICE

Line voltage, signal, and relay wiring must be rated for at least 221 °F (105 °C).

NOTICE

If metal conduit is used with the Rosemount™ CX1100 Remote Transmitter, reliably bond the conduit to protective earth. The grounding plate inside the Rosemount CX1100 Remote Transmitter is not bonded to PE and does not provide adequate grounding.

3.1 Installation specifications - interconnect cable

Customer supplied cable up to 200 ft. (60 m) long, rated for -40 to 194 °F (-40 to 90 °C) and voltage 300 VACrms.

Heater power: 3 multi conductor 18ga shielded cable to connect the heater control signal

Probe sensing: 3 twisted pair conductors 22ga overall shielded cable to connect the TC, O₂, and CJC signals.

Cable may be purchased as two separate cables.

3.2 Connect the cables

Raw voltages from the oxygen sensor and heater thermocouple are transmitted from the Rosemount CX1100 Probe to the Rosemount CX1100 Remote Transmitter. The remote transmitter also controls power to the probe heater in order to maintain the correct sensor temperature.

This arrangement calls for interconnect wiring consisting of nine conductors. Given the recommended wire specifications, the maximum length for this cable is 200 ft (60 m) (refer to [Section 3.1](#)).

NOTICE

To maintain EMC/EMI noise protection, connect the customer supplied 9 conductor cable and cable glands properly to ground.

Procedure

1. Run the signal and power cables between the probe and the installation site for the optional Rosemount CX1100 Remote Transmitter.
2. Remove the covers from the probe and the remote transmitter (if applicable).
3. Feed all probe wiring through the conduit port of the probe.
4. Refer to [Figure 3-2](#). Connect probe heater power leads to probe connector.
5. Connect O2 signal, thermocouple, and cold junction (CJC) wires from probe to the Rosemount CX1100 Remote Transmitter.
6. At the Rosemount CX1100 Remote Transmitter, connect the cable leads to the connectors on the sensor board as indicated in [Figure 3-1](#).

Figure 3-1: Wiring Diagram

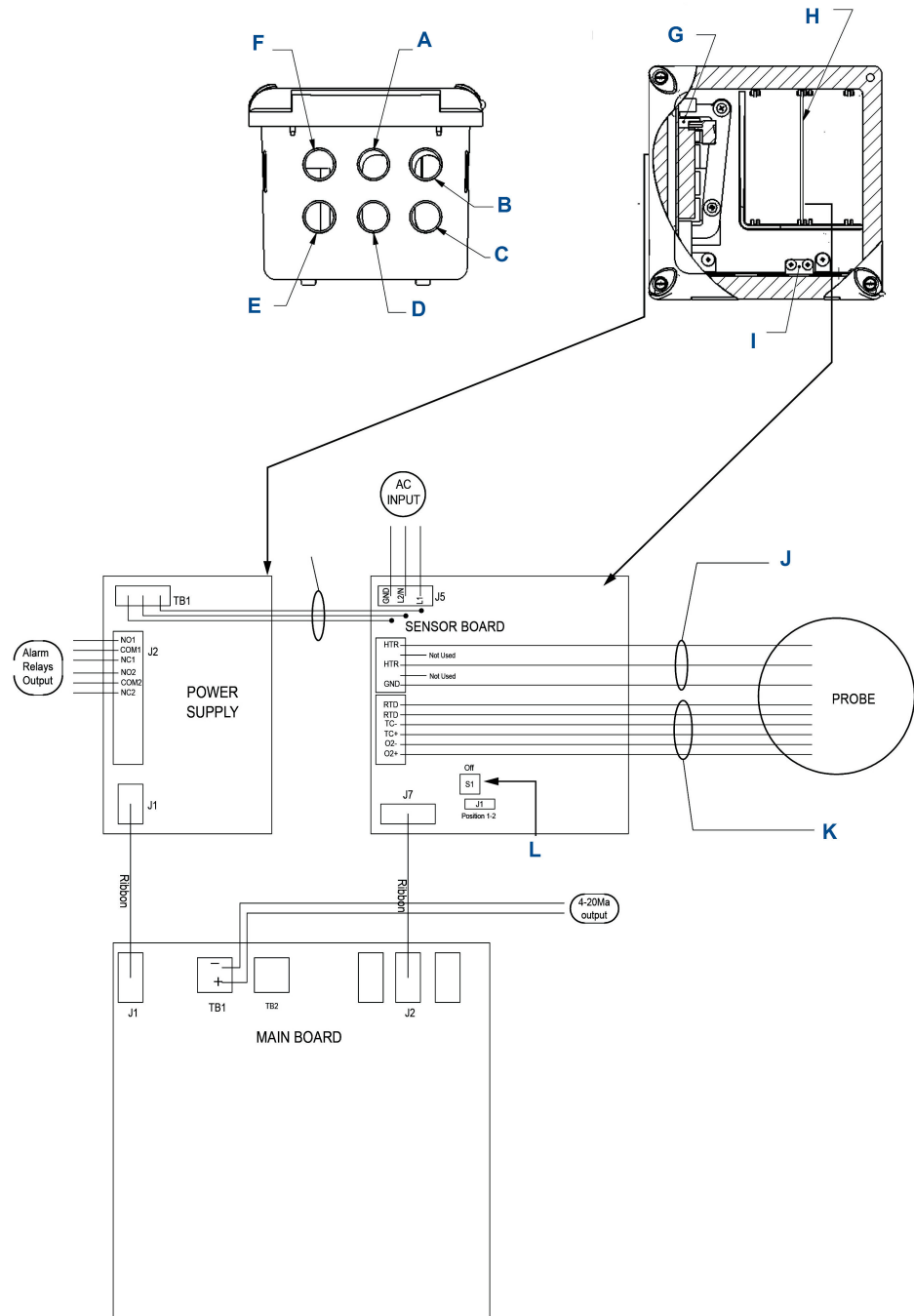

- A. Heater power to probe
- B. Alternate 4-20 mA out
- C. Signal from probe
- D. Power to remote transmitter
- E. Alarm relay

- F. 4-20 mA out
- G. Power supply
- H. Combustion sensor
- I. Shield ground
- J. Heater power terminates to underside of the sensor board.
- K. Probe sensing connect shield to GND
- L. S1 Dip switch is for factory use only and should be in the Off position.

AC power wires from power supply board to the underside of the sensor board are provided with the sensor board.

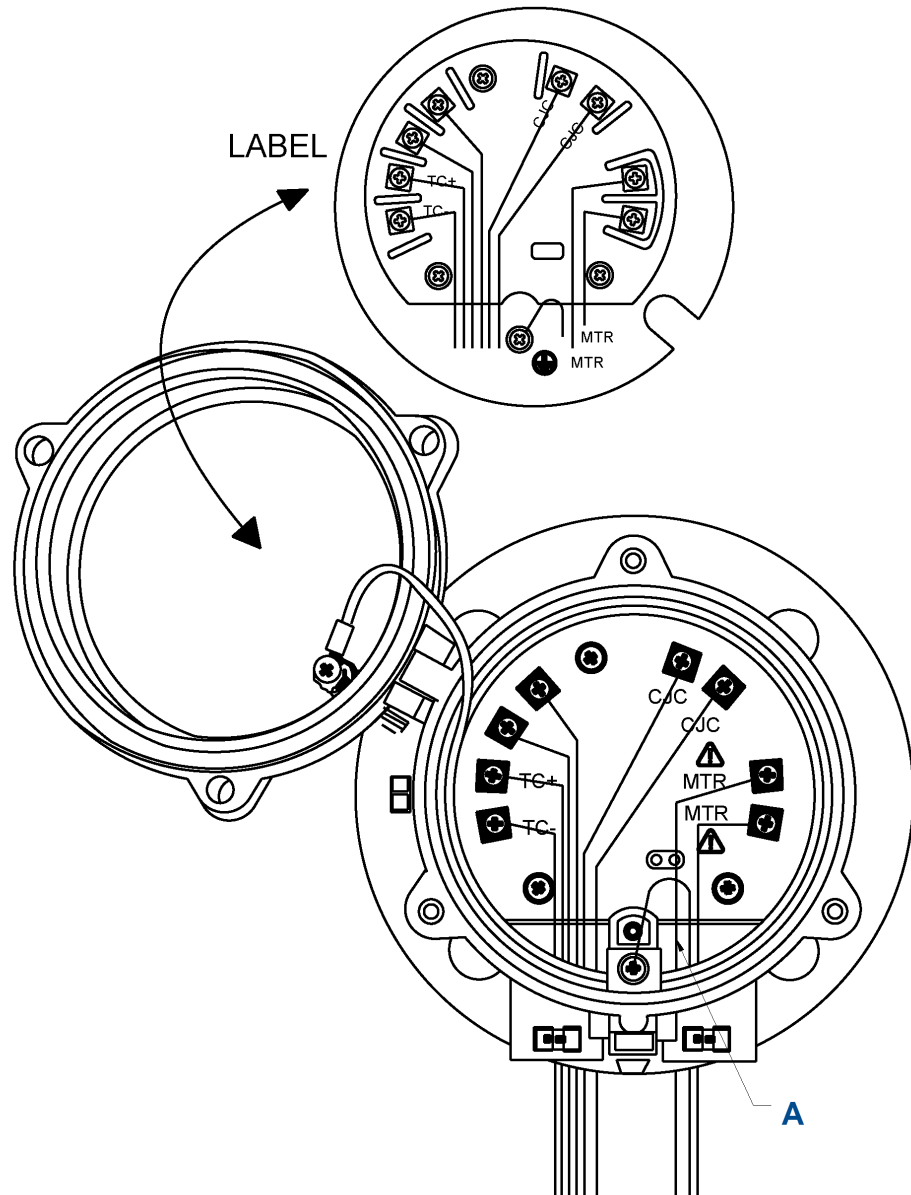
Figure 3-2: Closeup Wiring Diagram

A. M4 X 0.7 X 8 pan head screw machine screw (internal ground)

4 Startup

1. Apply AC line power to the Rosemount™ CX1100 Remote Transmitter.

The probe takes approximately 45 minutes to warm up to the 1357 °F (736 °C) setpoint. The 4-20 mA signal remains at a default value of 3.5 mA, and the O₂ reading remains at 0% through the warmup period.

2. After warmup, the probe begins reading oxygen, and the 4-20 mA output is based on the default range of 0-10% O₂.

If there is an error condition at startup, an alarm message is displayed on the Rosemount CX1100 Remote Transmitter.

5 Calibration and maintenance

The Rosemount™ CX1100 In Situ Oxygen Transmitter can be calibrated in the installed position without removing the instrument from the process duct and also while the combustion process is online. Gas is applied to the sensor through the calibration gas fitting. New Rosemount CX1100 In Situ Oxygen Transmitter systems are factory calibrated and are generally acceptable for initial startup and operation. High accuracy can be gained by calibrating a system during normal operating conditions. Emerson™ recommends calibrating on a semi-annual to annual basis for most applications; however actual calibration frequency may vary per process unit.

Calibrations are conducted using a two point calibration. Factory calibration uses 0.4% O₂ and 8.0% O₂ gases with a balance of nitrogen and is therefore recommended. Calibration gases with other oxygen concentrations are acceptable. If using different calibration gas values, additional configuration through the Rosemount CX1100 Remote Transmitter is required. Emerson does not recommend pure nitrogen as a calibration gas.

5.1 Procedure

The calibration of the Rosemount CX1100 Probe is initiated from the Rosemount CX1100 Remote Transmitter. The Rosemount CX1100 Remote Transmitter display prompts you with the calibration instructions.

1. Press the **x1** or **x2** menu button on the Rosemount CX1100 Remote Transmitter display to enter the probe.
2. Navigate, using **Up** and **Down** buttons to `Setup`; press **Enter**.
3. Navigate to `Cal Gas values`; press **Enter**.
4. Navigate to `Cal Gas 1` and press **Enter** twice to highlight the value setting.
5. Use the **Up** and **Down** buttons to set `Cal Gas 1` value and **Left** and **Right** buttons to move to decimals setting.
6. After setting the correct value, press **Enter** and press **Left** to go to the Calibration Setup for `Cal Gas 2`, `Gas time`, and `Purge time` settings.
7. After setting the values (0.4% O₂, 8.0% O₂, and 300s are the defaults), press **Left** to go up to the **Calibration** submenu.
8. Navigate using the **Up** and **Down** buttons to `Calibration` and press **Enter** to start.
9. Follow the instructions on the display, manually applying calibration gases (0.4% and 8.0% O₂ at 5 SCFH are recommended) to the calibration port.
10. After the calibration is finished, press **Left** and use the **Up** and **Down** buttons to check the current and previous 10 calibrations log.

After completing the procedure, the Rosemount CX1100 software calculates new calibration values and determines whether they meet an acceptance criteria. If successful, the new calibration values automatically replace the previous values. In the event the

calibration values do not meet the accepted performance criteria, the existing calibration values remain in effect, and Emerson recommends replacing the Rosemount CX1100 Probe.

⚠ CAUTION!

EQUIPMENT DAMAGE

Make sure that the calibration gas cap is replaced tightly after calibration is complete. Many combustion processes operate at a slight negative pressure (draft pressure) and can draw ambient air down the cal gas lines and into the sensing cell, causing a false elevated oxygen reading. The same phenomenon is possible if the calibration gas hoses become degraded or loose.

6 Rosemount™ CX1100 In Situ Oxygen Transmitter menu trees

6.1 System menu tree

Figure 6-1: System Menu Tree

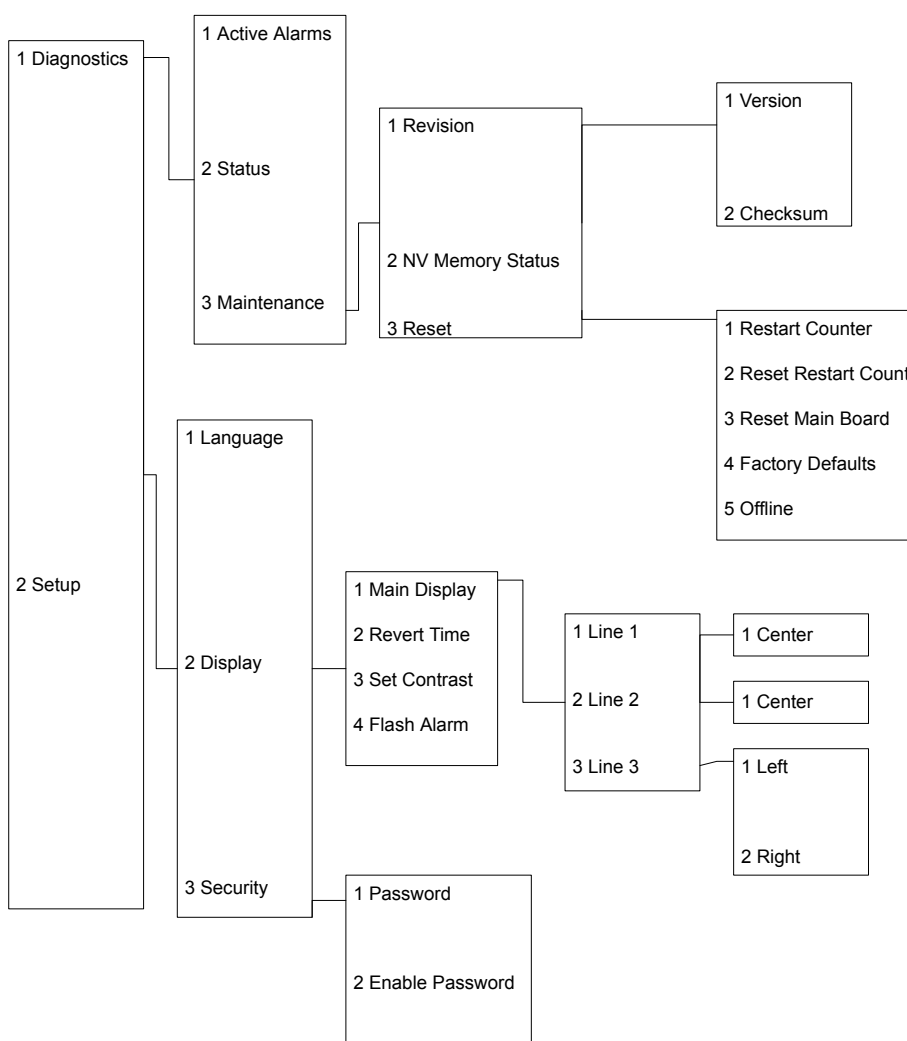

6.2 Probe menu tree

Figure 6-2: Probe Menu Tree

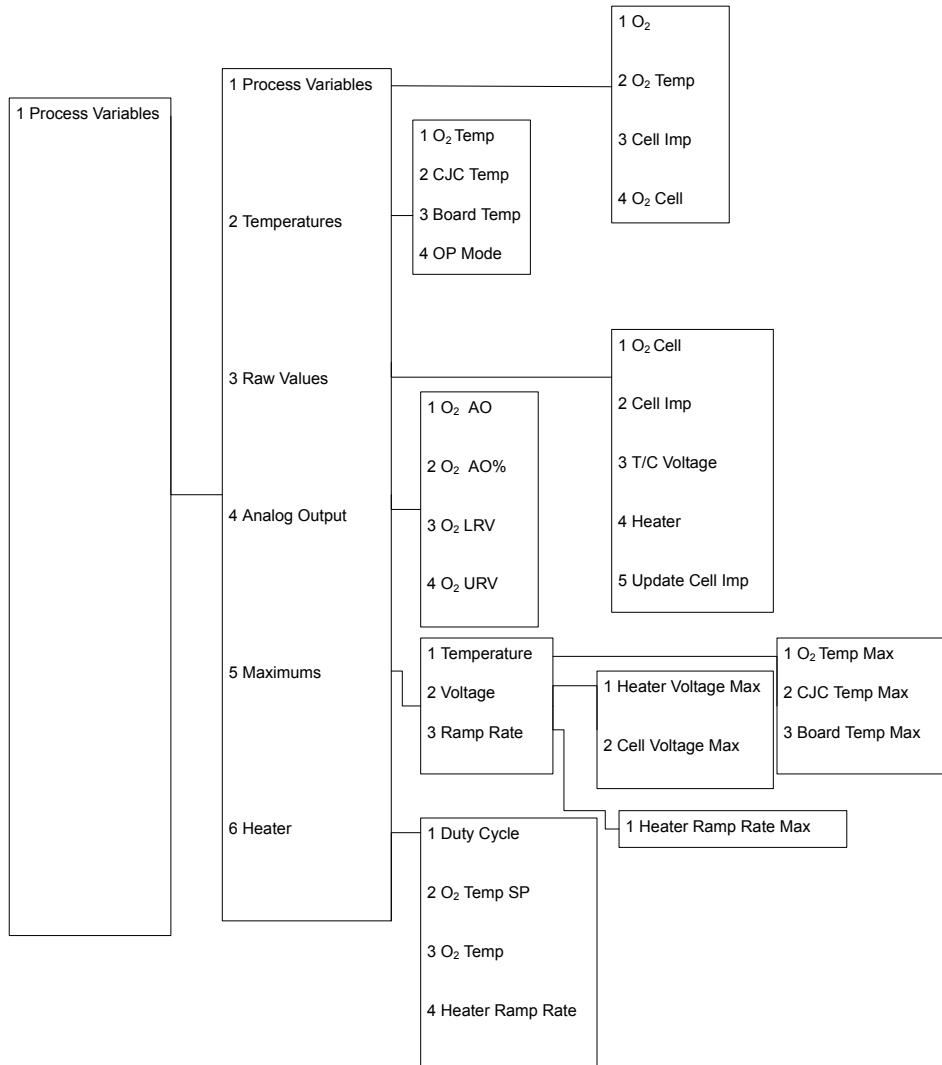

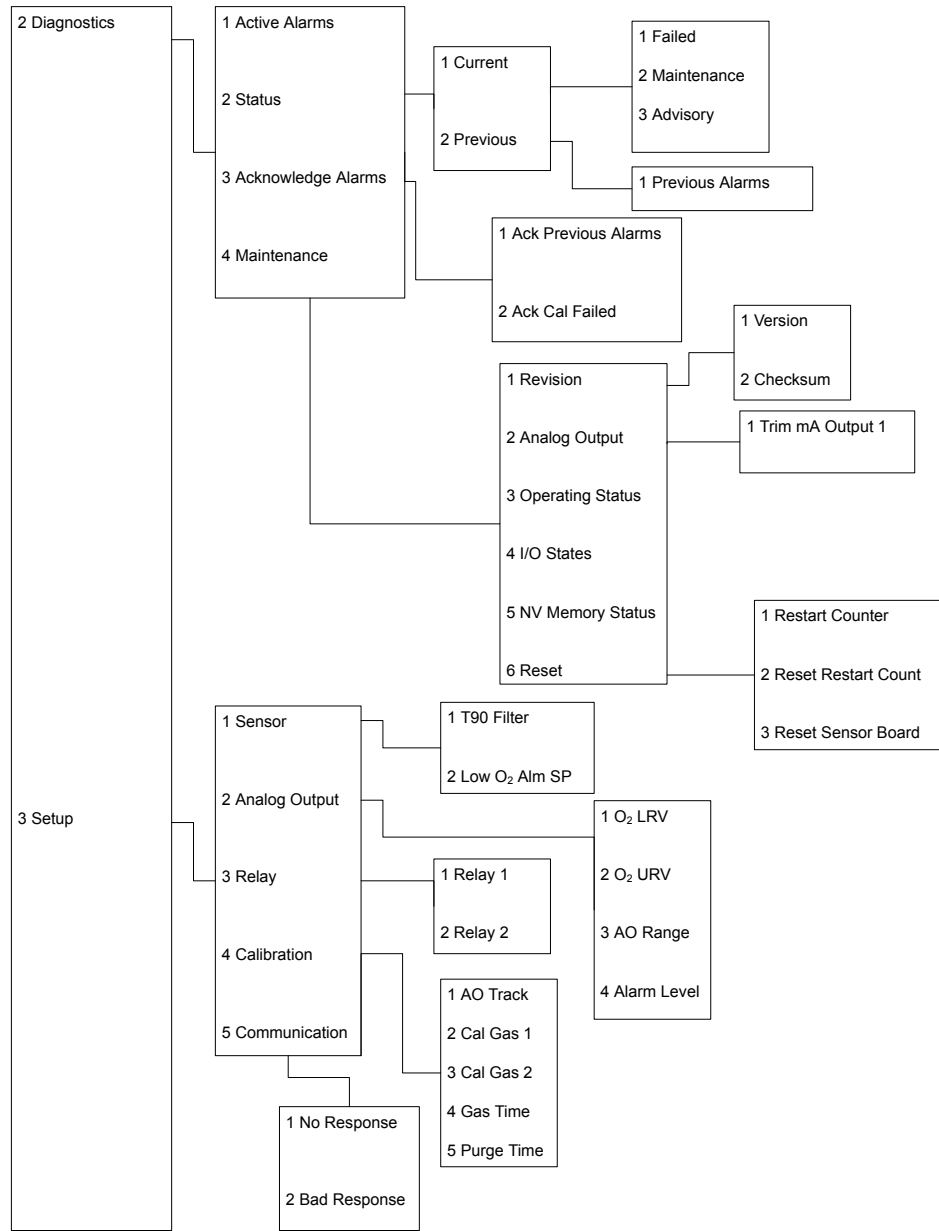

7 Parameters

7.1 System and probe parameters

Table 7-1: System Parameters

Parameter label	Description
Active Alarms	Alarms
Status	Alarm status bits
Version	Main board software version number
Checksum	Main board software checksum
Restart Counter	Main board restarted counter
Offline	The number of times the sensor board is disconnected from the main board since last power up
Language	Supported languages
Line 1 Center	Main display Line 1 data
Line 2 Center	Main display Line 2 data
Line 3 Left	Main display Line 3 left hand side data
Line 3 Right	Main display Line 3 right hand side data
Revert time	The time set for the display to revert back to the main display after the period of time with no button press (2-9999 min)
Contrast	Display contrast (110 - 200)
Flash Alarm	Turn off/on the main display flashing when alarms detected. (No/Yes)
Password	User password: 4 numeric digits. (0 - 9999)
Enable Password	Disable/Enable password protection. (No/Yes)
NV Memory Status	Main board nonvolatile data memory diagnostic.

Table 7-2: Probe Parameters

Parameter label	Description
O ₂	Current oxygen concentration value
O ₂ Temp	Current O ₂ sensor temperature
Cell Imp	Cell impedance/sensor resistance measured
O ₂ Cell	Raw voltage value for ZrO ₂ sensor
CJC Temp	Current cold junction temperature

Table 7-2: Probe Parameters (continued)

Parameter label	Description
Board Temp	Current electronics temperature measured at the sensor board
OP Mode	Device operating mode
T/C Voltage	O ₂ T/C voltage
Heater	Heater voltage
O ₂ AO	Analog output value represents the O ₂ concentration measurement
O ₂ AO%	Analog output percentage for O ₂ AO
O ₂ Temp Max	This is the highest O ₂ sensor temperature reached since last reset.
CJC Temp Max	This is the highest temperature reached at the cold junction since last reset.
Board Temp Max	This is the highest temperature reached at the sensor board since last reset.
Heater Voltage Max	This is the highest heater voltage reached since last reset.
Cell Voltage Max	This is the highest cell voltage reached since last reset.
Heater Ramp Rate Max	This is the highest heater ramp rate reached since last reset.
Duty Cycle	PID temperature set point
O ₂ Temp Sp	Current O ₂ sensor temperature
Active Alarms	Current alarms
Failed	Alarm status
Maintenance	Alarm status
Advisory	Alarm status
Previous Alarms	Previous alarms
Operating Status	Operating status
I/O States	I/O state
Version	Sensor board software version number
Checksum	Sensor board software checksum
NV Memory Status	Sensor board nonvolatile data memory diagnostic
Restart Counter	Sensor board software restarts counter.
T90 Filter	Analog output T90 time. It represents the time to take a step change in oxygen to reach 90% of the final value at the filter output. (0-300 sec)
Low O ₂ Alm SP	Low O ₂ alarm threshold (0.0 - 50.0%)

Table 7-2: Probe Parameters (continued)

Parameter label	Description
O ₂ LRV	Primary variable, O ₂ %, lower range value. (0.0% only)
O ₂ URV	Primary variable, O ₂ % upper range value (1.0% - 50.0%)
AO Range	Analog output polarity
Alarm Level	O ₂ alarm level
Relay 1	Alarm Relay 1 mode
Relay 2	Alarm Relay 2 mode
AO Track	Analog output track O ₂ sensor measurement during a calibration
Cal Gas 1	Test Gas 1 value. This is the actual value of the gas being applied during the Test Gas 1 phase of a calibration. (0.05 - 50.0%)
Cal Gas 2	Test Gas 2 value. This is the actual value of the gas being applied during the Test Gas 2 phase of calibration. (0.05 - 50.0%)
Gas Time	Test gas application time. This is the length of time test gases are applied to the O ₂ probe during low or high test gas phase of a calibration. (60 - 1200 sec)
Purge Time	Test gas purge time. This is the length of time before the output will be returned to the process reading after a calibration. (60 - 1200 sec)
Imp Check Hold	Time to hold analog output during impedance check. (0 - 60 sec) (<i>Factory mode only</i>)
Remote CJC	Use local or remote CJC measurement for correction. (No/Yes) (<i>Factory mode only</i>)
Raw Counts Cell Voltage	O ₂ sensor voltage raw counts. (<i>Factory mode only</i>)
Raw Counts Cell Imp	Cell impedance/sensor resistance raw counts. (<i>Factory mode only</i>)
Raw Counts T/C Voltage	O ₂ T/C raw counts. (<i>Factory mode only</i>)
Raw Counts Heater Voltage	Heater voltage raw counts. (<i>Factory mode only</i>)
Cal State	This represents the state of the calibration cycle it is in.
Time Remain	Time remaining in the present calibration cycle state.
Slope	Current calibration slope. This is the slope value that was calculated as a result of the last successful calibration. (34.5 to 57.5 mV/Dec)

Table 7-2: Probe Parameters (continued)

Parameter label	Description
Constant	Current calibration constant. This is the constant value that was calculated as a result of the last successful calibration. (-20.0 to 20.0 mV)
Impedance	Cell impedance. This is the sensor resistance that was calculated as a result of the last successful calibration.
Time	Time stamp of the last successful calibration
Calibration Log Slope	Previous calibration slope. There are ten calibration results. 1 is the most recent, and 10 is the least recent calibration slope.
Calibration Log Constant	Previous calibration constant. there are ten calibration results. 1 is the most recent, and 10 is the least recent calibration constant.
Calibration Log Impedance	Previous cell impedance. This is the sensor resistance that was calculated as a result of previous successful calibration. There are ten calibration results. Index 1 is the most recent, and Index 10 is the least recent sensor resistance measured.
Calibration Log Log Time	Time stamp of the previous successful calibration. There are ten calibration time stamps. Index 1 is the most recent, and Index 10 is the least recent time stamp.
Cal Result	Calibration result

7.2 Rosemount™ CX1100 In Situ Oxygen Transmitter system alarms

Table 7-3: System Alarms

Alarm label	Help messages and recommended actions
NV Memory Fail	Checksum error was detected in the nonvolatile memory configuration data when the unit was turned on. Default values have been loaded. Check to see that your configurations have not been changed. Cycle the power to clear alarm.
SB Disconnect	Communication failure detected between the sensor board and the main board, indicating the sensor board has been disconnected from the main board. Check the connecting cable pins.

Table 7-3: System Alarms (continued)

Alarm label	Help messages and recommended actions
SB Mismatch	The sensor type does not match, indicating wrong sensor board is connected.
SB Version	The sensor board software version does not match the expected version, indicating the sensor board software needs to be upgraded. Place the jumper on J1 of the sensor board and cycle the power to start the sensor board software upgrade.
SB Bootload Mode	The Bootload Mode jumper at J1 of the sensor board is on at power up. This mode should only be used to upgrade the sensor board software. Remove the jumper from J1 of the sensor board and cycle the power to clear the alarm.

Table 7-4: Probe Alarms

Alarm label	Help messages and recommended actions
O ₂ T/C Reversed	The sensor heater thermocouple voltage is reading a negative voltage, indicating the thermocouple wire connections may be reversed. Check wiring.
NV Memory Fail	Checksum error was detected in the nonvolatile memory configuration data when the unit was turned on. Default values have been loaded. Check to see that your configurations have not been changed. Cycle the power to clear alarm.
Board Temp High	The electronics board temperature reading is above the threshold. The board may not function correctly.
Factory Mode	The Factory Mode switch is set to On at power up. This mode should only be used for factory setup. Turn off the Factory Mode switch and cycle the power to clear alarm.
Program Integrity	Software checksum error detected when the unit was turned on. Please replace sensor board.
O ₂ T/C Shorted	This diagnostic is only intended to detect a copper short of the thermocouple connections at the electronics connector. The cell heater T/C voltage is reading close to zero, indicating the thermocouple wires may be shorted.
O ₂ Sensor Open	The cell impedance voltage is reading out of normal range, indicating the sensor wires may be disconnected or the sensor junction may be open. Check wiring.
O ₂ T/C Open	The sensor heater thermocouple voltage is out of range, indicating the T/C wires may be disconnected, or the T/C junction may be open. Check wiring.
O ₂ Temp Low	The sensor heater temperature is below the low temperature threshold.

Table 7-4: Probe Alarms (continued)

Alarm label	Help messages and recommended actions
O ₂ Temp High	The sensor heater temperature is above the high temperature threshold.
RTD Open	The CJC temperature is out of range, indicating the RTD may be open. Check RTD wiring.
Cal Failed	Calibration has failed. Check the Cal Result for more details. Acknowledge <code>Calibration Failed</code> or recalibrate to clear alarm.
Low O ₂	The O ₂ reading is below the threshold. The threshold is defined by the "Low O ₂ Alm SP".

Appendix A

Rosemount™ CX1100 product certifications

A.1 European Directive information

A copy of the EC Declaration of Conformity can be found at the end of the Quick Start Guide. The most recent revision of the EC Declaration of Conformity can be found at Emerson.com/Rosemount.

A.2 Ordinary location certification

As standard, the transmitter has been examined and tested to determine that the design meets the basic electrical, mechanical, and fire protection requirements by a nationally recognized test laboratory (NRTL) as accredited by the Federal Occupational Safety and Health Administration (OSHA).

A.3 Installing equipment in North America

The US National Electrical Code (NEC) and the Canadian Electrical Code (CEC) permit the use of Division marked equipment in Zones and Zone marked equipment in Divisions. The marking must be suitable for the area classification, gas, and temperature class. This information is clearly defined in the respective codes.

A.4 Rosemount CX1100 In-Situ Oxygen Transmitter

A.4.1 North America

CSA

Certificate: 70172073

Standards: CAN/CSA C22.2 No. 61010-1-12, CAN/CSA C22.2 No. 61010-2-010:15, UL 61010-1 (3rd Edition), UL 61010-2-10 (3rd Edition), UL 50E (2012), C22.2 No. 94.2-07, IEC 60529:2013 (Edition 2.2)

Markings: Type 4X, IP66





Condition of acceptability:

1. The measuring of net O₂ range is limited 0-23%.
2. The equipment shall be installed in accordance with manufacturer's specification by qualified personnel.
3. This equipment is for permanently connection to power source with approved power cord at end installation in accordance with local codes.
4. The Probe unit of the equipment shall be connected to PE separately at end installation.
5. End installation to provide the means of disconnection from power sources.
6. End installation to comply with the requirement of IP66 and 4X.

GLOBAL HEADQUARTERS

Emerson Automation Solutions
6021 Innovation Blvd
Shakopee, MN 55379, USA

 +1 800 999 9307 or +1 952 906 8888

 +1 952 949 7001

 gas.csc@emerson.com

NORTH AMERICA

Rosemount
8200 Market Boulevard
Chanhassen, MN 55317

 +1 800 999 9307

 +1 952 949 7001

 gas.csc@emerson.com

EUROPE

Emerson Automation Solutions
Neuhofstrasse 19a P.O. Box 1046
CH-6340 Baar
Switzerland

 + 41 (0) 41 768 6111

 + 41 (0) 41 768 6300

 gas.csc@emerson.com

MIDDLE EAST AND AFRICA

Emerson Automation Solutions
Emerson FZE
Jebel Ali Free Zone
Dubai, United Arab Emirates, P.O. Box 17033

 +971 4 811 8100

 +971 4 886 5465

 gas.csc@emerson.com

ASIA-PACIFIC

Emerson Automation Solutions
1 Pandan Crescent
Singapore 128461
Singapore

 +65 777 8211

 +65 777 0947

 gas.csc@emerson.com

 [Linkedin.com/company/Emerson-Automation-Solutions](https://www.linkedin.com/company/Emerson-Automation-Solutions)

 twitter.com/rosemount_news

 [Facebook.com/Rosemount](https://www.facebook.com/Rosemount)

 [youtube.com/RosemountMeasurement](https://www.youtube.com/RosemountMeasurement)

 [google.com/+RosemountMeasurement](https://plus.google.com/+RosemountMeasurement)

 AnalyticExpert.com

©2018 Emerson. All rights reserved.

The Emerson logo is a trademark and service mark of Emerson Electric Co. Rosemount is a mark of one of the Emerson family of companies. All other marks are the property of their respective owners.