

# Technical Information

## Cleanfit CPA871

Flexible retractable process assembly for water, wastewater, chemical industry and heavy industry



### Application

Cleanfit CPA871 is a flexible process retractable assembly for applications with standard 12 mm sensors for pH and redox.

The assembly was developed to guarantee maximum safety in:

- Water and wastewater including sea water
- Chemical industry
- Oil and gas
- Electricity and energy
- Hazardous areas
- Primaries and metals

### Your benefits

- Maximum operational safety: Intelligent functions ensure that the assembly is not inserted into the process without the sensor or unintentionally retracted from the process if the assembly is in measuring position.
- Suitable for demanding applications: The optional immersion chamber eliminates problems associated with media that form buildup.
- Robust assembly design: The metallic support housing ensures that the service chamber is mechanically stable.
- Flexible in adapting to your process: A wide range of process connections and materials in contact with the medium; for corrosive media and hazardous areas also.

---

## Function and system design

---

|                          |  |
|--------------------------|--|
| <b>Mode of operation</b> | <p>With the Cleanfit CPA871 retractable assembly, you can carry out pH, ORP and other measurements reliably using suitable sensors. You can remove, clean, sterilize or calibrate/adjust the sensors without interrupting the process.</p> <p>The assembly can be installed in both vessels and pipes.</p>   |
| <b>Design</b>            | <p>The retractable assembly has a modular design and can therefore be flexibly adapted to a wide array of applications. It is available with both a manual and a pneumatic drive.</p> <p>A choice of two chamber systems is available for the assembly:</p> <ul style="list-style-type: none"><li>▪ Standard version or</li><li>▪ Immersion chamber version</li></ul> <p>It is possible to choose between the following strokes for the electrode guide:</p> <ul style="list-style-type: none"><li>▪ 36 mm for standard version and immersion chamber version</li><li>▪ 78 mm for standard version</li></ul> <p>All common process connections are available:</p> <p>Clamp/flange EN1092-1/flange ASME B16.5/flange JIS B2220/dairy fitting/thread</p>   |
| <b>Safety function</b>   | <p><b>Locking mechanism without sensor</b></p> <p>If the sensor is not installed, it is not possible to pneumatically or manually move the assembly from the service position to the measuring position.</p> <p><b>Manual or pneumatic drive</b></p> <p>The sensor can be driven both manually and pneumatically. The manual drive has a self-retaining thread to hold the sensor in any intermediate position. The manual drive can be used for process pressures up to 8 bar (116 psi). The pneumatic drive can be used for process pressures up to 16 bar (232 psi).</p> <p><b>Limit position locking if compressed air fails</b></p> <p>If the compressed air fails in pneumatic assemblies, the assembly remains in the position previously selected. The process pressure cannot force it out of the measuring position and into an intermediate position.</p> <p><b>Limit position locking with manual drive</b></p> <p>For position locking, the manual version has an unlocking button in both the measuring position and the service position.</p> <p><b>Impossible to remove sensor in the measuring position</b></p> <p>The protection cap for covering the sensor has the following functions:</p> <ul style="list-style-type: none"><li>▪ Mechanical sensor safety</li><li>▪ Prevents sensor removal in the assembly measuring position</li></ul> <p>The bottom part of the protection cap is partly inserted into the drive and cannot be opened as a result.</p> <p><b>Non-rotating sensor guide</b></p> <p>During insertion/retraction, the position of the ridges of the immersion tube in the area of the sensor head retains the pre-setting once selected. This guarantees optimum and clear positioning of the sensor in the process and during cleaning.</p> <p><b>Limit position detection (can be retrofitted)</b></p> <p>In the case of assemblies with a pneumatic drive, the service and measuring position of the sensor are detected inductively and reported to connected systems (only for the measuring position in the case of the manual drive assembly).</p> |

**Elements**

The assembly is available with a manual or pneumatic drive.

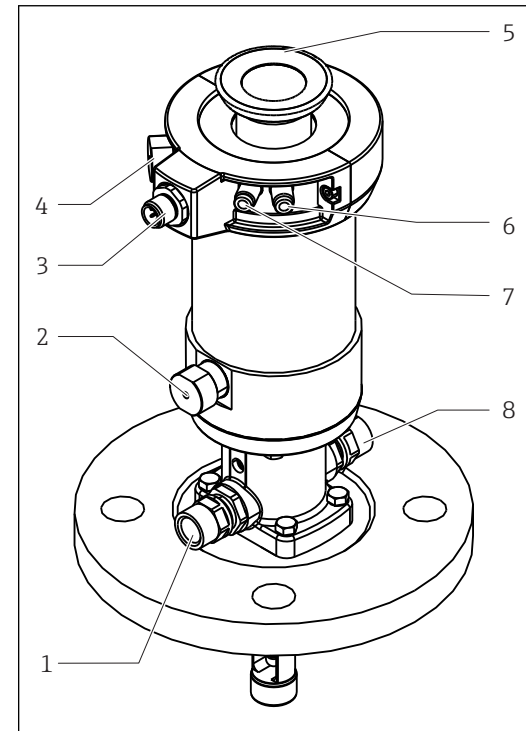
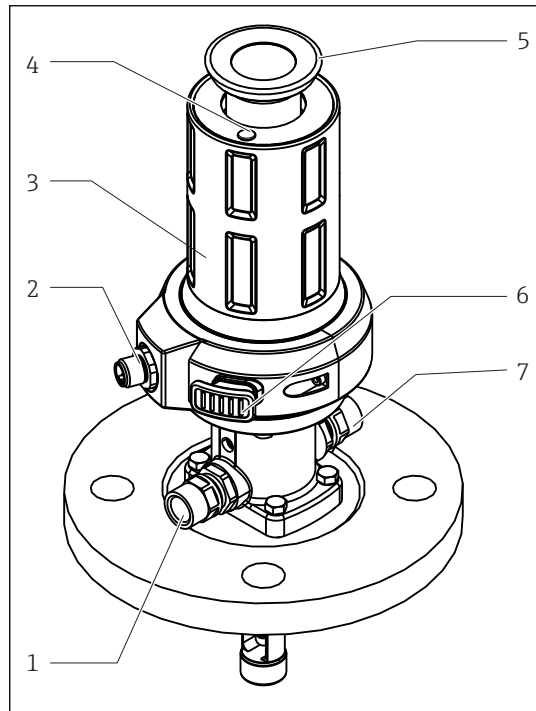

1 Assembly with manual drive (without protection cap)

- 1 Rinse connection
- 2 Connection for limit position switch
- 3 Manual drive (fulcrum shaft)
- 4 Unlocking button (service position)
- 5 Fastening ring for protective cap
- 6 Unlocking button (measuring position)
- 7 Rinse connection

2 Assembly with pneumatic drive (without protective cap)

- 1 Rinse connection
- 2 Automatic limit position lock, process
- 3 Connection for limit position switch
- 4 Automatic limit position lock, service
- 5 Fastening ring for protective cap
- 6 Pneumatic connection (move to measuring position)
- 7 Pneumatic connection (move to service position)
- 8 Rinse connection

**Measuring system**

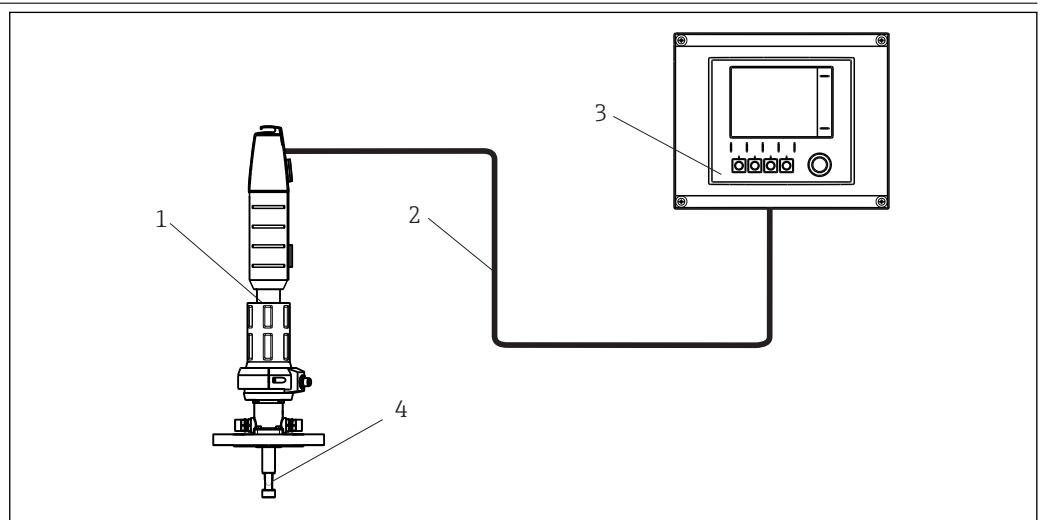

3 Measuring system (example)

- 1 Cleanfit assembly CPA871
- 2 Measuring cable
- 3 Liquiline CM44x transmitter
- 4 Sensor

**Immersion chamber**

The special immersion chamber version is the perfect solution when the sensor descends to greater immersion depths in media that cause buildup and media with a tendency to form condensation. In the process medium, the sensor guide containing the installed sensor is almost completely surrounded by the service chamber. This means that there is minimal contact with the medium. The seals are thus protected from damage when the sensor is moving from measuring to service position.

**Assignment of rinse connections**

The inlet and outlet of the service chamber are fixed. The outlet of the service chamber is located under the leakage borehole. The leakage hole is sealed with an M5 screw.

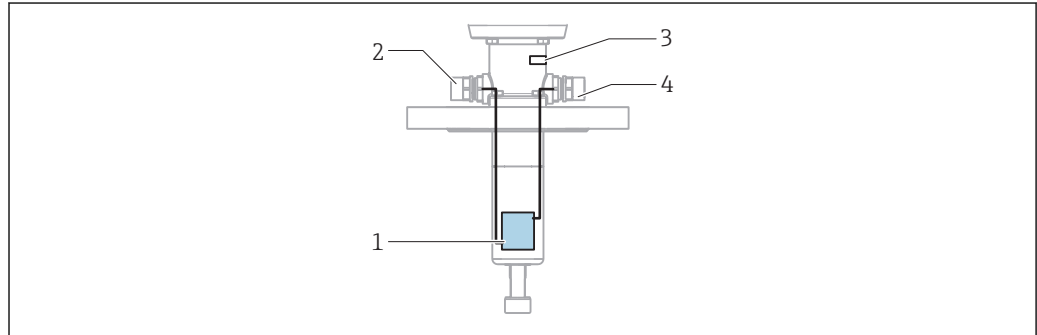

A0028521

 4 Connection of service chamber in the immersion chamber version

- 1 Service chamber
- 2 Service chamber inlet
- 3 Leakage hole
- 4 Service chamber outlet

**Service chamber**

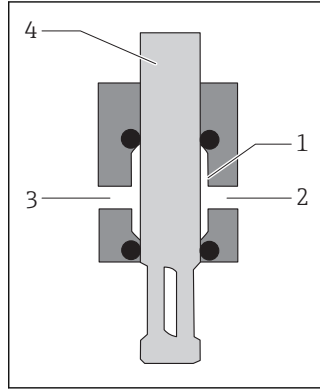

A0024239

- 1 Service chamber
- 2 Service chamber outlet
- 3 Service chamber inlet
- 4 Sensor guide

In measuring position, the service chamber is separated from the process by the process seals and sensor guide. No process medium can get into the service chamber.

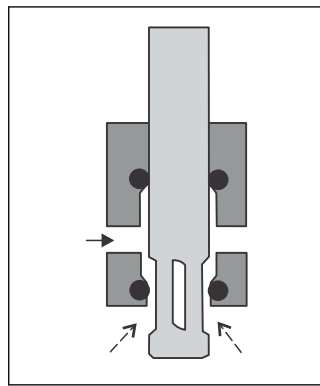

A0024240

When the assembly is moving from measuring to service position (or the other way around), the service chamber is no longer separated from the process. Now process medium can get into the service chamber. To prevent this, you can rinse the service chamber with a sealing medium via the service chamber inlet. This also means that process medium, which may contain solid particles, does not need to be removed via the service chamber.

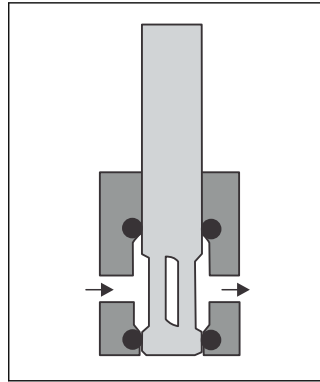

A0024241

In service position, the service chamber is separated from the process.

## Cleanfit Control

### Integration in an automatic measuring system

Cleanfit Control converts electrical signals into pneumatic signals. Signals coming from the relays or outputs of the transmitter are used to control pneumatically-operated retractable assemblies or pumps. Pilot valves are used for this purpose.

Cleanfit Control allows automatic cleaning of sensors installed in retractable assemblies. This means that sensor performance can be maintained at a high level without any interruption to the process.

It is the function of the Cleanfit Control CYC25 to integrate the actuators into the cleaning program in a safety-oriented manner. That is why the actuators, i.e. assembly, valves and pumps, are not connected directly via the relays to the Liquiline CM44x. Instead they are connected to the Cleanfit Control CYC25. The 24V DC power supply to these actuators, as well as the compressed air supply, are provided by the customer.

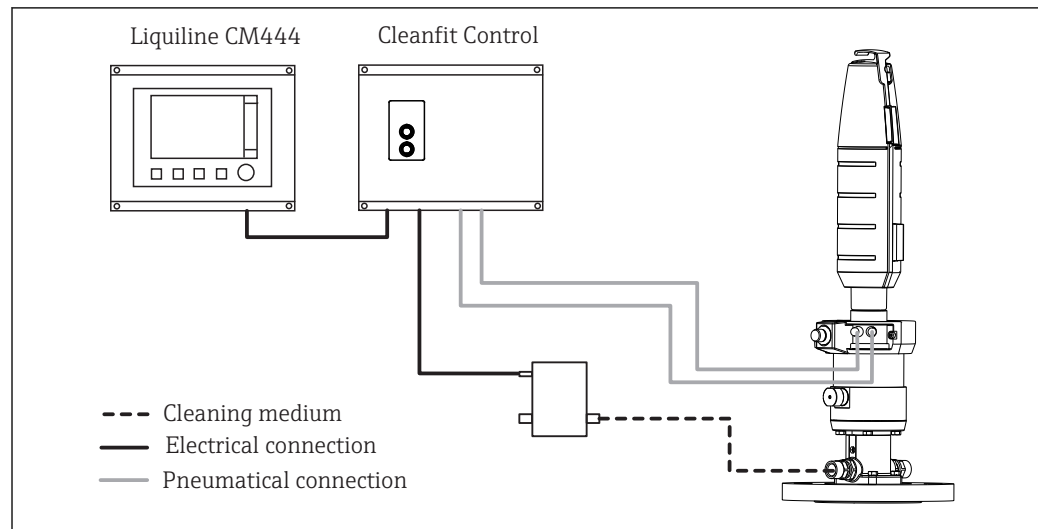

A0030123-EN

5 Control of cleaning with Cleanfit Control  
Cleanfit Control is available as accessory.

## Control unit Air-Trol 500

Air-Trol 500 allows you to move all pneumatically-controlled retractable assemblies manually.

- Easy installation
- Purely pneumatic functional unit
- Measuring or service mode of assembly:
  - Simple toggle switch
  - Optical display
- Push-button switch for pneumatic valve for cleaning agent, used to clean sensor

Air-Trol 500 is available as accessory.

## Installation

### Orientation

The assembly is designed for installation on tanks and pipes. Suitable process connections must be available for this.

#### NOTICE

##### Frost damage to the assembly

- ▶ If used outdoors, ensure that water cannot penetrate the drive.

The assembly is designed in such a way that there are no restrictions with regard to the orientation.



The sensor that is used can restrict the orientation.



Ensure compliance with the Operating Instructions of the sensor installed.

### Pneumatic connections for automatic operation

Prerequisites:

- Air pressure 4 to 7 bar (absolute pressure) (58 to 102 psi)
- Compressed air quality in accordance with ISO 8573-1:2001 Quality class 3.3.3 or 3.4.3
- Solids class 3 (max. 5 µm, max. 5 mg/m<sup>3</sup>, contamination with particles)
- Water content for temperatures ≥ 15 °C: Class 4 pressure condensation point 3 °C or lower
- Water content for temperatures of 5 to 15 °C: Class 3 pressure condensation point -20 °C or lower
- Oil content: Class 3 (max. 1 mg/m<sup>3</sup>)
- Air temperature: 5 °C or higher
- No continuous air consumption
- Minimum nominal diameter of air pipes: 2 mm (0.08 ")

A dual-operating cylinder is used to operate the pneumatic drive.

An automatic limit position lock both in service and measuring position secures the assembly to prevent it from moving inadvertently in the event of a failure in the control air. The assembly remains in the relevant position.

Connection: Push connector M5, hose 4/2 mm OD/ID (adapter for 6/4 mm OD/ID enclosed)

#### NOTICE

##### Air pressure too high

Damage to seals.

- ▶ Connect a pressure-reducing valve upstream if the air pressure is likely to rise to above 7 bar (absolute pressure) (102 psi) (even short pressure surges).

### Rinse connection

The service chamber connections make it possible to rinse the chamber (including the sensor) with water or cleaning solution. The pressure difference between the sealing water and process must not exceed 6 bar (87 psi).

The sealing water pressure must not exceed 8 bar (116 psi) in manual mode and 16 bar (232 psi) in pneumatic mode.



Install a pressure-reducing valve upstream if there is a possibility that the sealing water pressure will increase to more than (8 bar (116 psi) or 16 bar (232 psi)) (including any short pressure surges).

#### NOTICE

##### Pressure difference too high between process and wastewater system or if rinse connections are not properly connected.

Damage to seals

- ▶ Close rinse connections.
- ▶ Pipe-fit rinse connections.
- ▶ Use sealing water function.

## Environment

**Ambient temperature range** -10 to +70 °C (+10 to +160 °F)

**Storage temperature**      -10 to +70 °C (+10 to +160 °F)



## Process

**Process temperature** -10 to +140 °C (14 to 284 °F) for all materials except PVDF and conductive PVDF  
 -10 to +100 / 90 °C (14 to 212 / 194 °F) for PVDF and conductive PVDF materials

**Process pressure for pneumatic drive** Materials: 1.4404, Alloy C22, PEEK  
 Basic and immersion chamber version: 16 bar (232 psi) up to 140 °C (284 °F)  
 Materials: PVDF, conductive PVDF  
 Basic version: 16 bar (232 psi) up to 100 °C (212 °F)  
 Immersion chamber version: 4 bar (58 psi) to 90 °C (194 °F)

**i** The service life of the seals is reduced if process temperatures are constantly high or if SIP is used. The other process conditions may also reduce the service life of the seals.

**i** Depending on the version, the process pressure must be reduced to insert/retract the assembly.

**Process pressure for manual drive** Materials: 1.4404, Alloy C22, PEEK  
 Basic and immersion chamber version: 8 bar (116 psi) up to 140 °C (284 °F)  
 Materials: PVDF, conductive PVDF  
 Basic version: 8 bar (116 psi) up to 100 °C (212 °F)  
 Immersion chamber version: 4 bar (58 psi) to 90 °C (194 °F)

**i** The service life of the seals is reduced if process temperatures are constantly high or if SIP is used. The other process conditions may also reduce the service life of the seals.

**Pressure-temperature ratings**

**Manual drive, movement of assembly up to 8 bar**

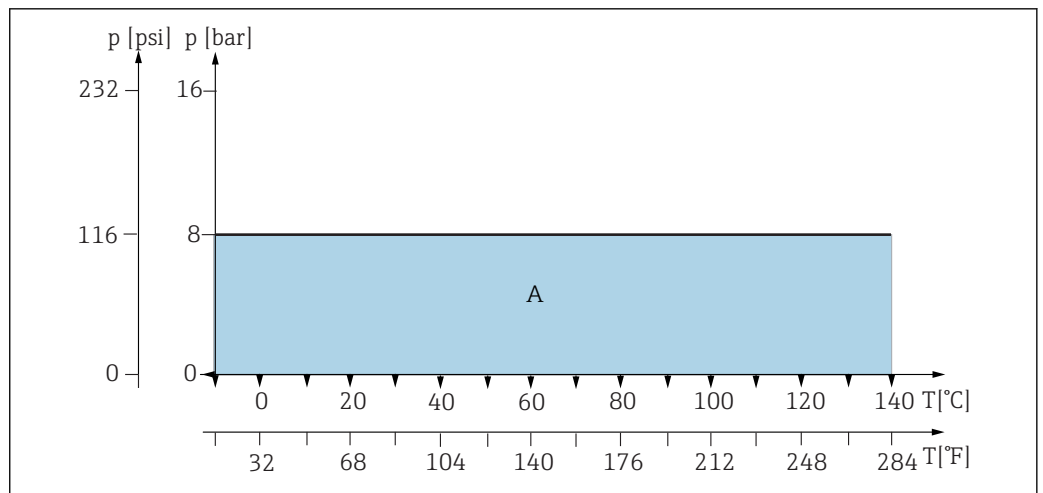

**6** Pressure temperature ratings for basic and immersion chamber version for materials 1.4404, Alloy C22 and PEEK

A Basic and immersion chamber version

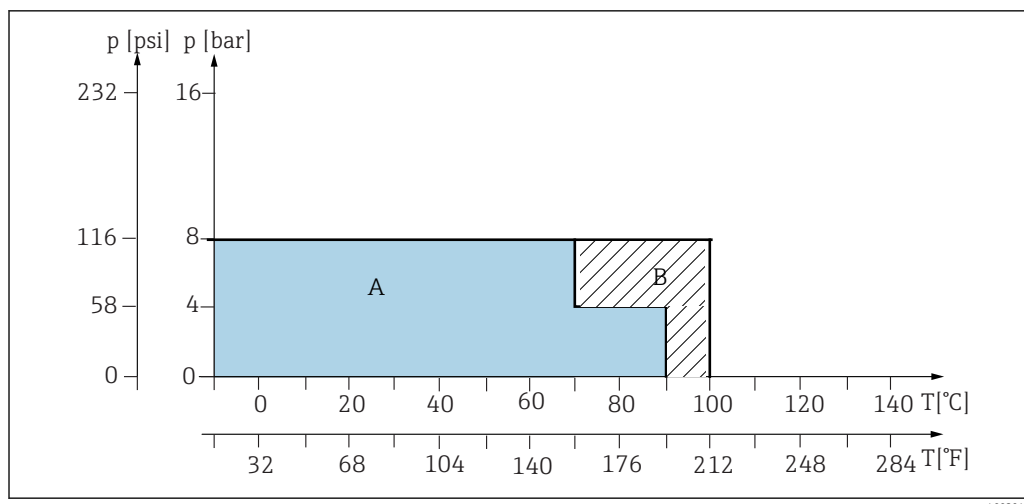

A0039155

7 Pressure temperature ratings for basic version for materials PVDF and conductive PVDF

- A Immersion chamber version  
B Basic version

### Pneumatic drive, movement of assembly up to 8 bar (static pressure resistance up to 16 bar)

#### NOTICE

The process seal can be damaged if pressure is too high during insertion/retraction.

Medium escaping from the assembly

- Assembly insertion/retraction at 8 bar.

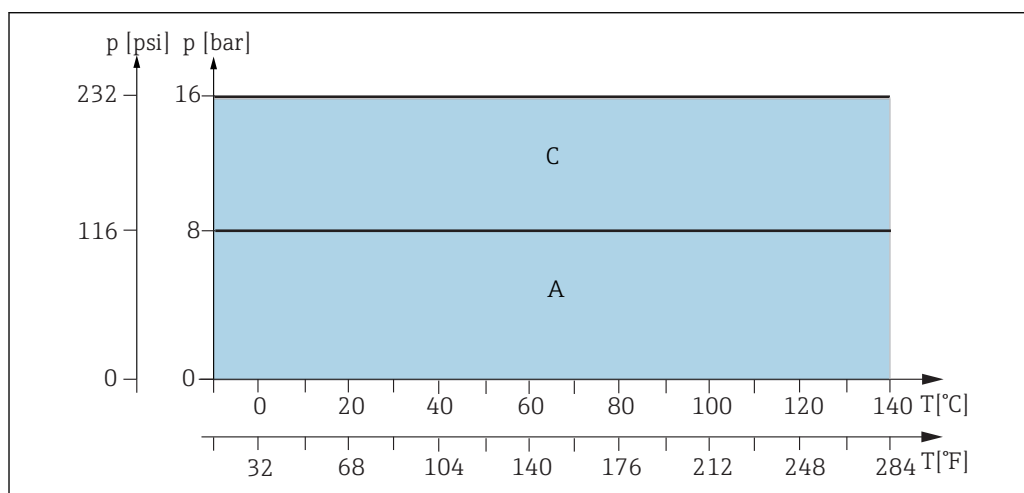

A0039268

8 Pressure temperature ratings for basic and immersion chamber version for materials 1.4404, Alloy C22 and PEEK (CPA871-++G/H++++++)

- A Basic and immersion chamber version  
C Static range, assembly insertion/retraction not permitted

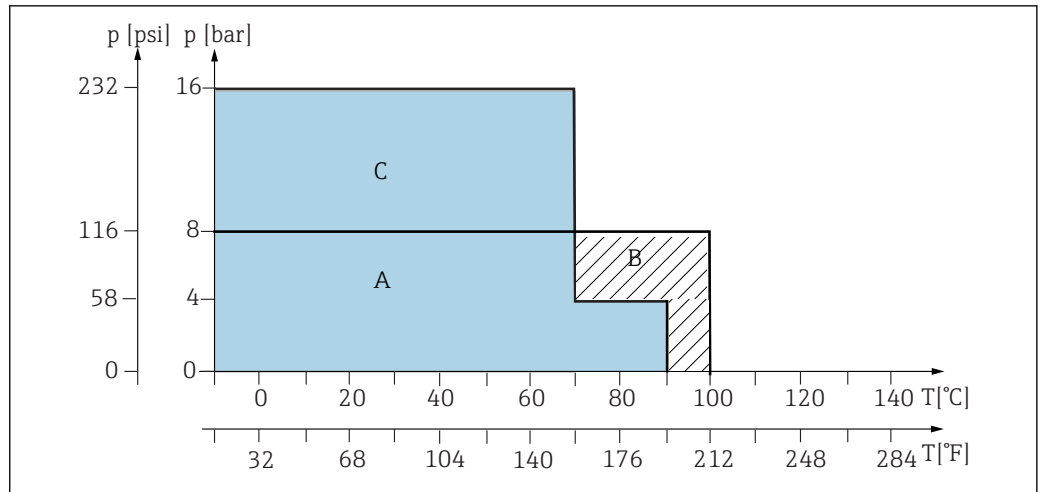

A0039267

9 Pressure temperature ratings for basic version for materials PVDF and conductive PVDF (CPA871-++G/H+++++)

- A Immersion chamber version
- B Basic version
- C Static range, assembly insertion/retraction not permitted

**Pneumatic drive, movement of assembly up to 16 bar**

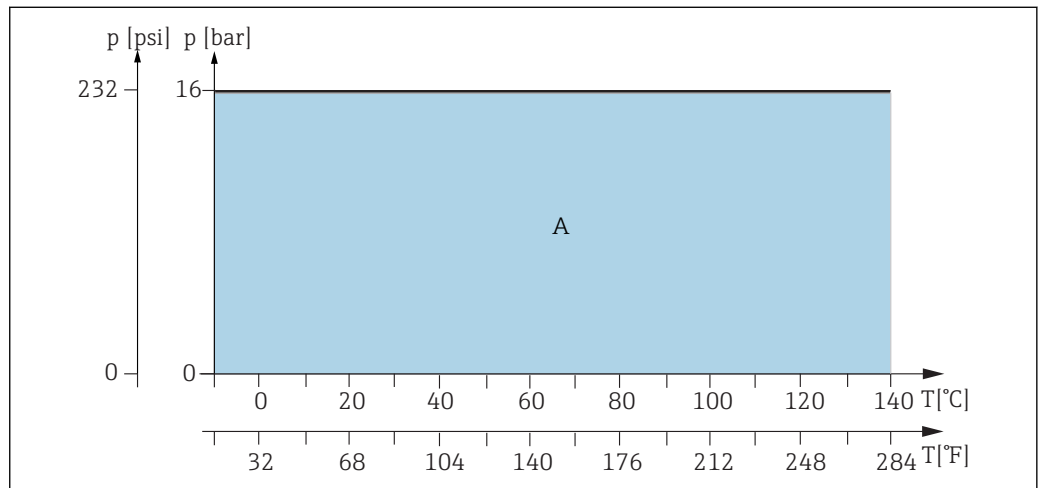

A0039157

10 Pressure temperature ratings for basic and immersion chamber version for materials 1.4404, Alloy C22 and PEEK (CPA871-++E/F+++++)

- A Basic and immersion chamber version

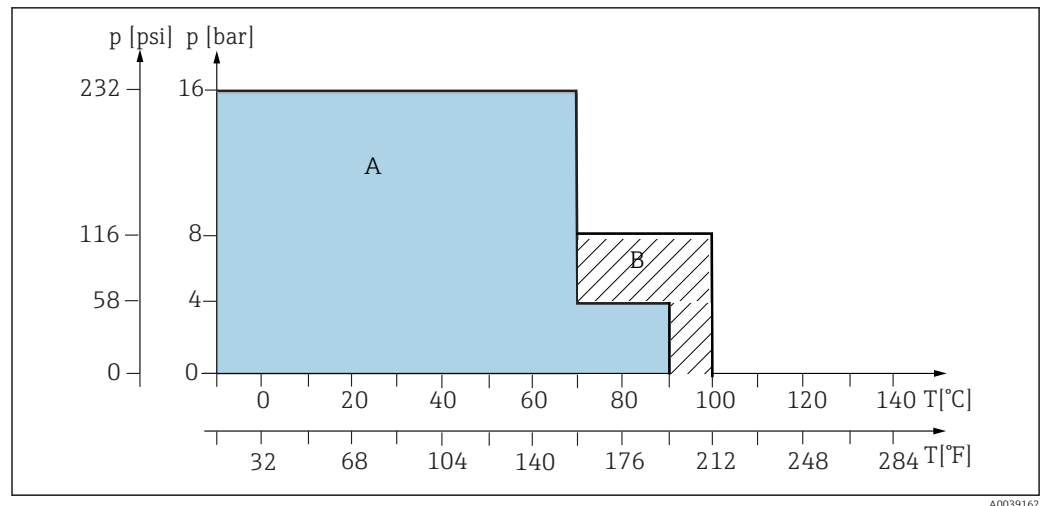

A0039162

11 Pressure temperature ratings for basic version for materials PVDF and conductive PVDF (CPA871-++E/F+ +++++)

- A Immersion chamber version  
B Basic version

## Mechanical construction

### Short version

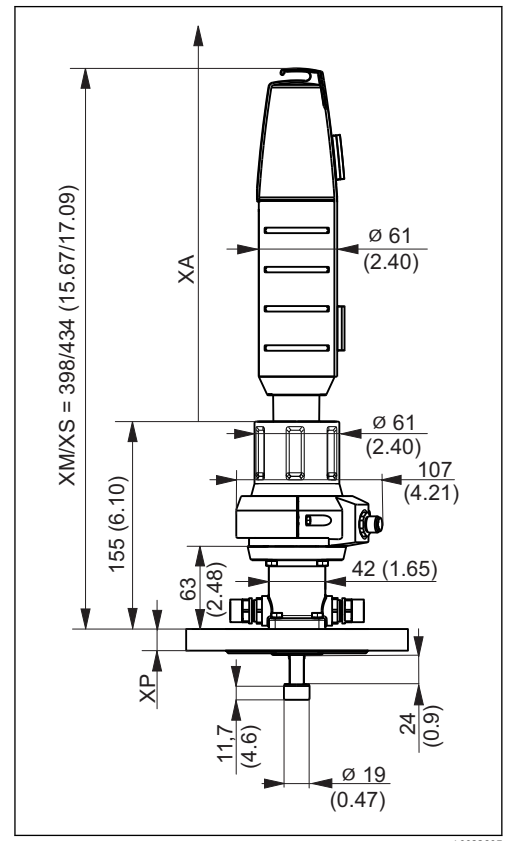
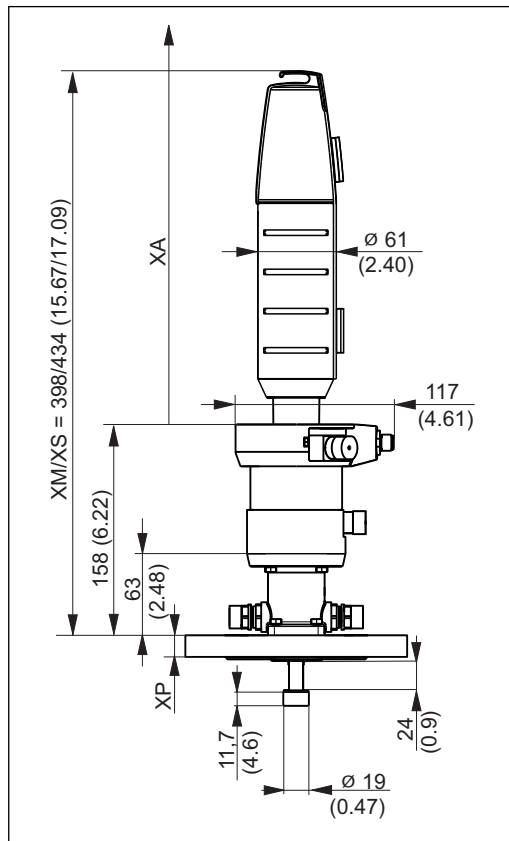

12 Pneumatic drive, short version, dimensions in mm (in)

13 Manual drive, short version, dimensions in mm (in)

*XM* Assembly in measuring position

*XS* Assembly in service position

*XP* Height of particular process connection (see table below)

*XA* Necessary mounting distance for sensor replacement

The mounting distance XA is 280 mm (11.02") for 120 mm sensors

The mounting distance XA is 408 mm (15.94") for 225 mm sensors

## Long version

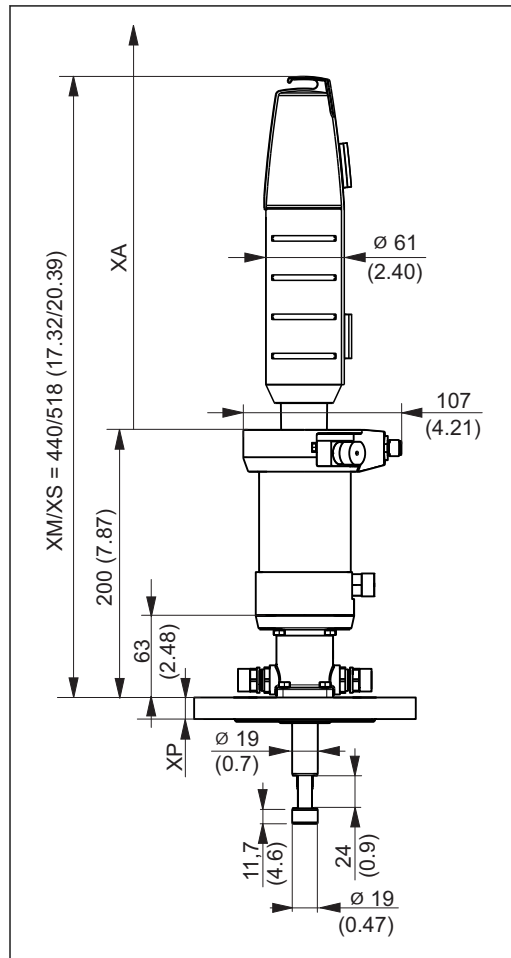

A0023895

14 Pneumatic drive, long version, dimensions in mm (in)

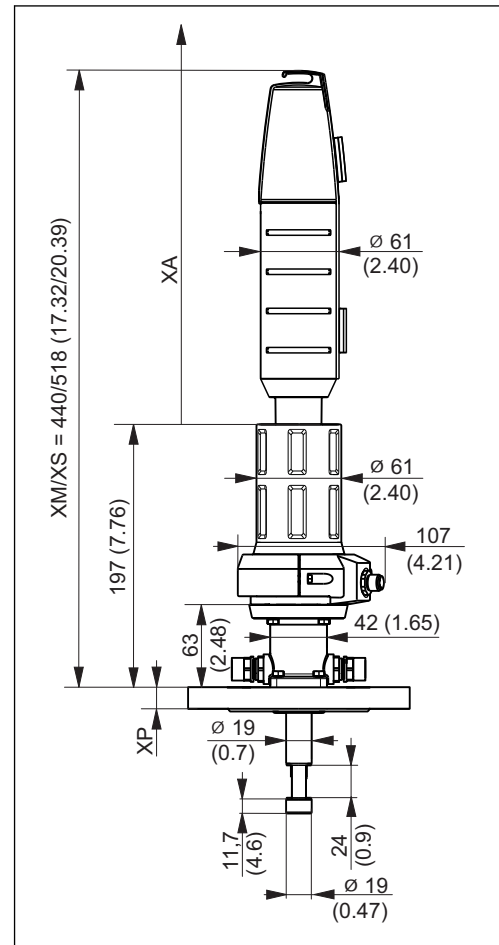

A0023898

15 Manual drive, long version, dimensions in mm (in)

- XM* Assembly in measuring position  
*XS* Assembly in service position  
*XP* Height of particular process connection (see table below)  
*XA* Necessary mounting distance for sensor replacement

The mounting distance XA is 360 mm (14.17") for 225 mm sensors

Immersion chamber version

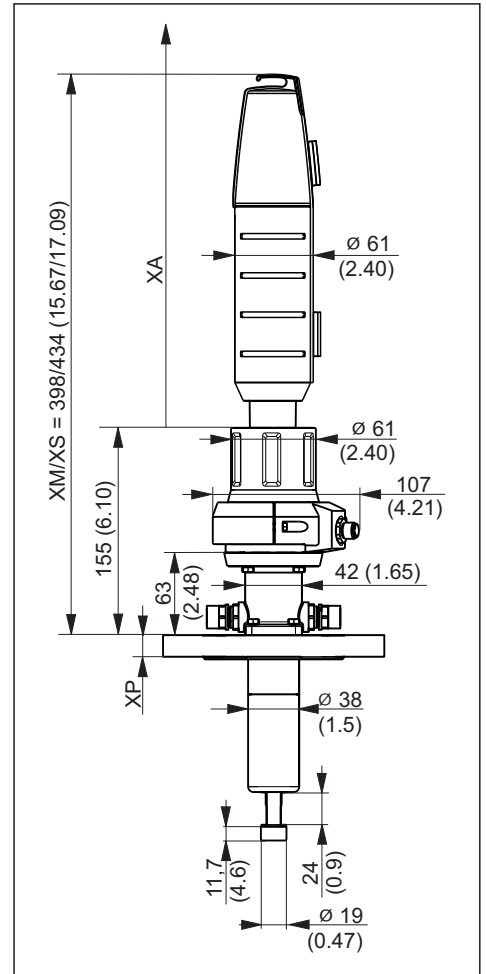
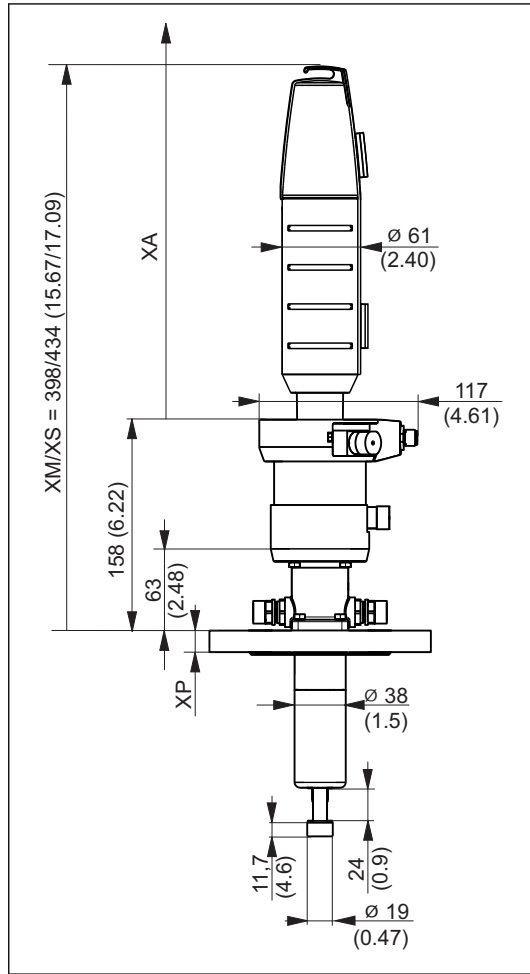







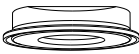

16 Immersion chamber version with pneumatic drive, dimensions in mm (in)

17 Immersion chamber version with manual drive, dimensions in mm (in)

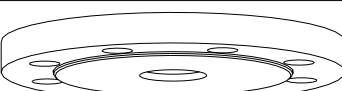
- XM Assembly in measuring position
- XS Assembly in service position
- XP Height of particular process connection (see table below)
- XA Necessary mounting distance for sensor replacement

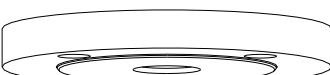
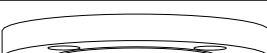
The mounting distance XA is 280 mm (11.02") for 225 mm sensors  
 The mounting distance XA is 570 mm (22.44") for 360 mm sensors

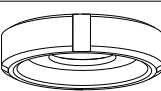
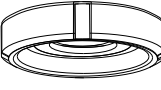
## Process connections

| Process connection                            |  | Height XP in mm (in) |
|---|--|----------------------|
| <b>CB</b> Clamp 2"<br>ISO2852, ASME BPE-2012  | <br>A0024100   | 16 (0.63)            |
| <b>CC</b> Clamp 2½"<br>ISO2852, ASME BPE-2012 | <br>A0024101   | 16 (0.63)            |
| <b>FA</b> Flange DN 40 PN16, EN1092-1         | <br>A0024102   | 18 (0.71)            |
| <b>FB</b> Flange DN 50 PN16, EN1092-1         | <br>A0024103   | 18 (0.71)            |
| <b>FC</b> Flange DN 80 PN10, EN1092-1         | <br>A0024104   | 20 (0.79)            |
| <b>FD</b> Flange 2" 150 lbs, ASME B16.5       | <br>A0024105   | 19.1 (0.75)          |
| <b>FE</b> Flange 3" 150 lbs, ASME B16.5       | <br>A0024106   | 23.8 (0.94)          |
| <b>FF</b> 10K50, JIS B2220                    | <br>A0024107 | 16 (0.63)            |
| <b>FG</b> 10K80, JIS B2220                    | <br>A0024108 | 18 (0.71)            |
| <b>MA</b> Dairy fitting DN 50 DIN 11851       | <br>A0024109 | 15.5 (0.61)          |
| <b>MB</b> Dairy fitting DN 65 DIN 11851       | <br>A0024110 | 15.5 (0.61)          |
| <b>HB</b> Thread NPT 1½"                      | <br>A0024111 | 40.5 (1.57)          |
| <b>NA</b><br>Thread ISO 228 G1¼               | <br>A0039368 | 31.1 (1.22)          |



## Immersion depths

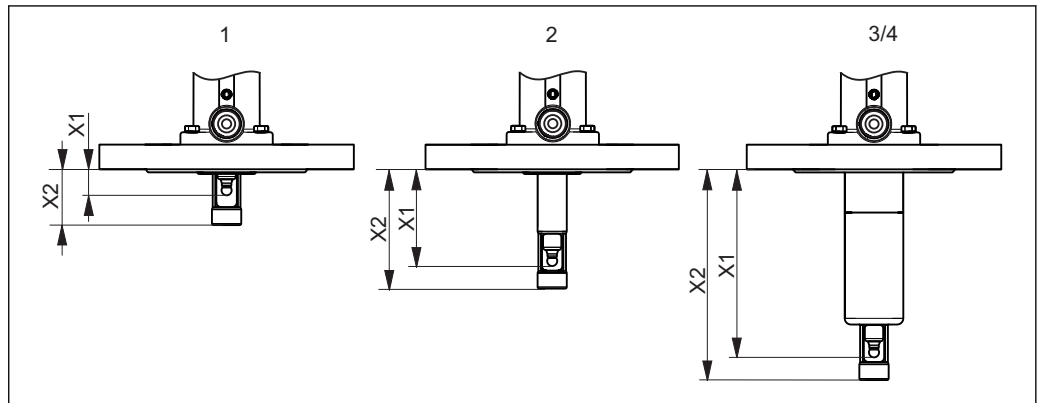

A0023893

18 Immersion depths in mm (in)

- 1 Short stroke, 36 mm (1.42 in)  
 2 Long stroke, 78 mm (3.07 in)  
 3 Immersion version

## Versions

| Process connection                    |    | 1           | 2           | 3            | 4            |
|---------------------------------------|----|-------------|-------------|--------------|--------------|
| CB Clamp ISO2852<br>ASME BPE-2012 2"  | X1 | 14.9 (0.59) | 61.0 (2.40) | 119.9 (4.72) | 171.9 (6.76) |
|                                       | X2 | 34.2 (1.35) | 75.7 (2.98) | 134.6 (5.30) | 186.6 (7.35) |
| CC Clamp ISO2852<br>ASME BPE-2012 2½" | X1 | 14.9 (0.59) | 61.0 (2.40) | 119.9 (4.72) | 171.9 (6.76) |
|                                       | X2 | 34.2 (1.35) | 75.7 (2.98) | 134.6 (5.30) | 186.6 (7.35) |
| FA Flange DN 40<br>EN1092-1           | X1 | 14.9 (0.59) | 61.0 (2.40) | 119.9 (4.72) | 171.9 (6.76) |
|                                       | X2 | 34.2 (1.35) | 75.7 (2.98) | 134.6 (5.30) | 186.6 (7.35) |
| FB Flange DN 50<br>EN1092-1           | X1 | 14.9 (0.59) | 61.0 (2.40) | 119.9 (4.72) | 171.9 (6.76) |
|                                       | X2 | 34.2 (1.35) | 75.7 (2.98) | 134.6 (5.30) | 186.6 (7.35) |
| FC Flange DN 80<br>EN1092-1           | X1 | 12.9 (0.51) | 59.0 (2.32) | 117.9 (4.64) | 169.9 (6.69) |
|                                       | X2 | 32.2 (1.27) | 73.7 (2.90) | 132.6 (5.22) | 184.6 (7.27) |
| FD Flange 2" 150 lbs<br>ASME B16.5    | X1 | 13.8 (0.54) | 59.9 (2.36) | 118.8 (4.68) | 170.9 (6.73) |
|                                       | X2 | 33.1 (1.30) | 74.6 (2.94) | 133.5 (5.26) | 185.6 (7.30) |
| FE Flange 3" 150 lbs<br>ASME B16.5    | X1 | -           | -           | 114.1 (4.49) | 166.1 (6.54) |
|                                       | X2 | -           | -           | 128.8 (5.07) | 180.8 (7.11) |
| FF Flange 10K50<br>JIS B2220          | X1 | 14.4 (0.57) | 61.3 (2.41) | 120.2 (4.73) | 172.2 (6.78) |
|                                       | X2 | 33.7 (1.33) | 76.0 (2.99) | 134.9 (5.31) | 186.9 (7.36) |
| FG Flange 10K80<br>JIS B2220          | X1 | 14.4 (0.57) | 60.5 (2.38) | 119.4 (4.70) | 171.4 (6.75) |
|                                       | X2 | 33.7 (1.33) | 75.2 (2.96) | 134.1 (5.28) | 186.1 (7.33) |
| HB Thread NPT 1½"                     | X1 | -           | 63.0 (2.48) | 121.9 (4.80) | 173.9 (6.85) |
|                                       | X2 | -           | 77.7 (3.06) | 136.6 (5.38) | 188.6 (7.40) |
| MA Dairy fitting<br>DN 50 DIN 11851   | X1 | 15.4 (0.61) | 61.5 (2.42) | 120.4 (4.74) | 172.4 (6.79) |
|                                       | X2 | 34.7 (1.37) | 76.2 (3.00) | 135.1 (5.32) | 187.1 (6.37) |
| MB Dairy fitting<br>DN 65 DIN 11851   | X1 | 15.4 (0.61) | 61.5 (2.42) | 120.4 (4.74) | 172.4 (6.79) |
|                                       | X2 | 34.7 (1.37) | 76.2 (3.00) | 135.1 (5.32) | 187.1 (6.37) |
| NA Thread ISO 228<br>G 1½"            | X1 | -           | 61.5 (2.42) | -            | -            |
|                                       | X2 | -           | 76.2 (3.00) | -            | -            |
|                                       | X3 | -           | 20.6 (0.81) | -            | -            |

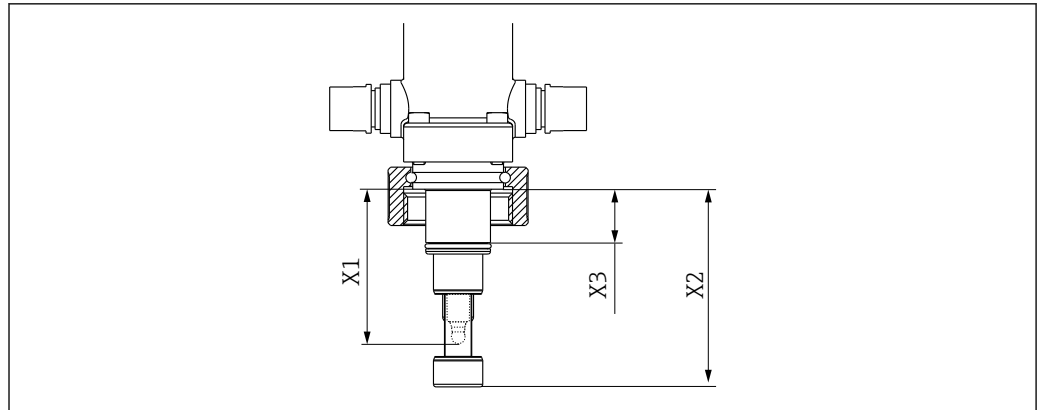

A0039342

19 Immersion depth in mm (in) for process connection NA thread ISO 228 G1¼

### Weight

Depends on version:

Pneumatic drive: 3.8 to 6 kg (8.4 to 13.2 lbs) depending on version

Manual drive: 3 to 4.5 kg (6.6 to 9.9 lbs) depending on version

### Materials

| In contact with medium                               |   |
|--|---|
| Seals:   | EPDM/FPM (Viton)/FFKM   |
| Immersion tube, process connection, service chamber: | Stainless steel 1.4404 (AISI 316L) Ra < 0.76/PEEK/Alloy C22<br>Ra < 0.76/PVDF/conductive PVDF |
| Rinse connections:                                   | Stainless steel 1.4404 (AISI 316L) and Alloy C22  |

| Not in contact with medium |   |
|----------------------------|---|
| Manual drive:              | Stainless steel 1.4301 (AISI 304) or 1.4404 (AISI 316L), plastics PPS CF15, PBT, PP |
| Pneumatic drive:           | Stainless steel 1.4301 (AISI 304) or 1.4404 (AISI 316L), plastics PBT, PP           |

---

|                |                           |                    |        |
|----------------|---------------------------|--------------------|--------|
| <b>Sensors</b> | Short version             | Gel sensors, ISFET | 120 mm |
|                |                           | Gel sensors, ISFET | 225 mm |
|                |                           | KCl sensors        | 225 mm |
|                | Long version              | Gel sensors, ISFET | 225 mm |
|                |                           | Gel sensors, ISFET | 360 mm |
|                | Immersion chamber version | Gel sensors, ISFET | 225 mm |
|                |                           | KCl sensors        | 360 mm |

---

|                          |                              |
|--------------------------|------------------------------|
| <b>Rinse connections</b> | Pipe 6/8 mm ID/OD            |
|                          | G $\frac{1}{4}$ internal     |
|                          | NPT-F $\frac{1}{4}$ internal |

## Limit position switches

With limit position detection, you can notify a system located downstream (transmitter, switching amplifier, output interface terminal) whether the assembly is in the measuring or service position (in the case of manual drive, only the measuring position is queried).

The limit position switches must be connected to output interface terminals (can be ordered as accessories) to enable power supply.

The assembly can be ordered directly with limit position detection, or it can be retrofitted at a later stage. The cable for the limit position switches must be ordered as an accessory.

### Feedback signals

The feedback signals are intrinsically safe. The approval for the feedback signals is no longer valid if they are not installed or connected correctly.

1. Ensure full compliance with manufacturer documentation.
2. Connect the feedback signals in accordance with the relevant instructions.

|                             |                              |
|-----------------------------|------------------------------|
| Switching element function: | NAMUR NC contact (inductive) |
| Switching distance:         | 1.5 mm (0.06 ")              |
| Nominal voltage:            | 8 V DC                       |
| Switching frequency:        | 0 to 5000 Hz                 |
| Housing material:           | Stainless steel              |

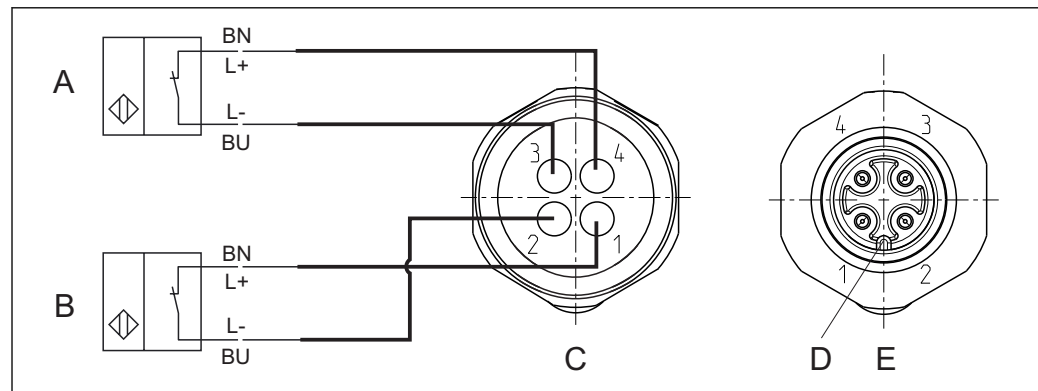

A0017831

### 20 Inductive limit position switches

- A Limit position switch, service position
- B Limit position switch, measuring position
- C Connector, M12, solder side (inside of assembly)
- D Coding
- E Connector, pin side (outside of assembly)

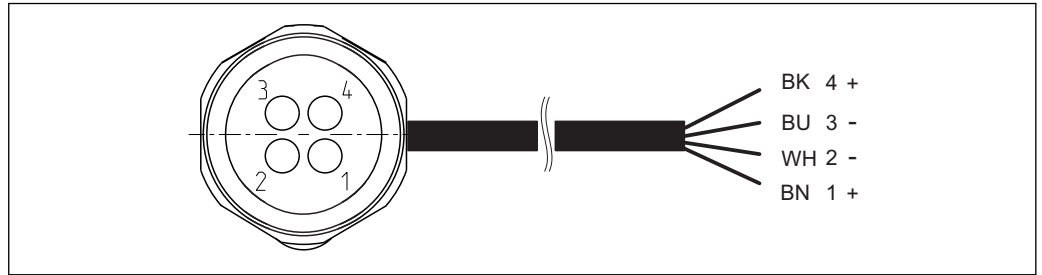

A0022163

21 Connecting cable for limit position switch on transmitter, switching amplifier, output interface terminal etc.

- 1 Measuring position
- 2 Measuring position
- 3 Service position
- 4 Service position

**i** Only pins 1 and 2 are assigned for manually activated assemblies with one switch (measuring position).

**i** NAMUR terminal (8 V DC) and connecting cable with blue marking available as accessories.

Signal table for limit position switches

| Position of assembly | Limit position switch, measuring position | Limit position switch, service position |
|----------------------|---|---|
| Measuring            | Active LOW ( $\geq 3$ mA)                 | Active LOW ( $\geq 3$ mA)               |
| Service              | Active HIGH ( $\leq 1$ mA)                | Active HIGH ( $\leq 1$ mA)              |

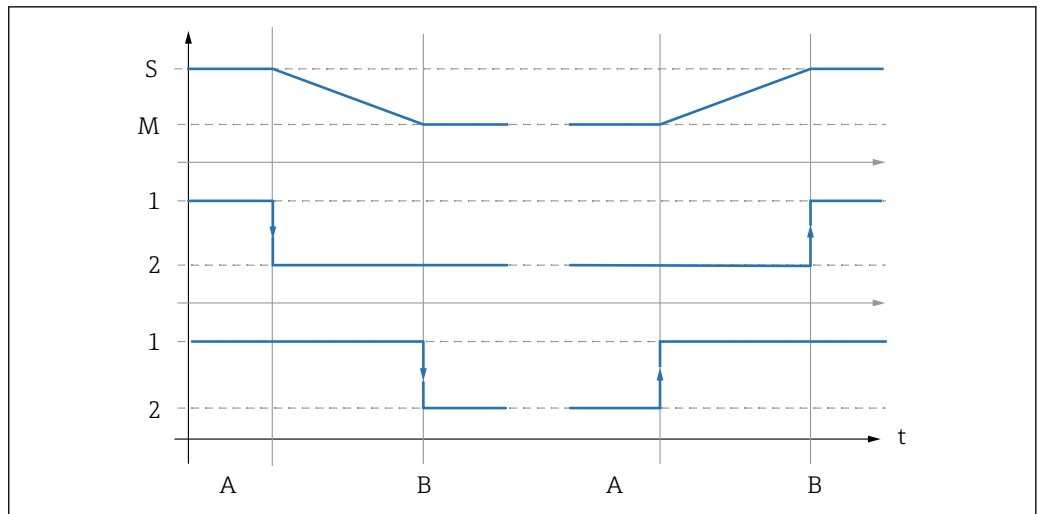

A0039144

22 Description of switching function

- S Service
- M Measuring
- 1 High
- 2 Low
- A Movement starts
- B Limit position reached

## Certificates and approvals

### **CRN**

The design of the assembly was reviewed and registered by the Canadian safety authorities for all Canadian provinces in accordance with the requirements of the "Canadian Registration Number (CRN)" system.

### **ATEX- 2014/34/EU**

The assembly does not fall within the scope of the directive. However, if conditions for safe use are adhered to, it may be deployed in the hazardous area.

### **DRGL- 2014/68/EU / PED- 2014/68/EU**

The assembly has been manufactured according to good engineering practice as per Article 4, Paragraph 3 of the Pressure Equipment Directive 2014/68/EU and is therefore not required to bear the CE label.

## Ordering information

---

### Ordering instructions

Create the order code for the assembly as follows:

1. Is the assembly used in the hazardous or non-hazardous area?
2. Select the drive type and the limit position switches.
3. Select the type of service chamber.
4. What material should the wetted seals be made of?
5. What material should the wetted surfaces be made of?
6. Select the suitable process connection.
7. Which connections should the service chamber have?

Order the accessories as follows:

- If you wish to order the accessories together with the assembly, then use the accessory code of the product structure.
- If you only wish to order accessories, then use the order numbers from the "Accessories" section.

---

### Product page

[www.endress.com/cpa871](http://www.endress.com/cpa871)

---

### Product Configurator

On the product page there is a **Configure** button to the right of the product image.

1. Click this button.
  - ↳ The Configurator opens in a separate window.
2. Select all the options to configure the device in line with your requirements.
  - ↳ In this way, you receive a valid and complete order code for the device.
3. Export the order code as a PDF or Excel file. To do so, click the appropriate button on the right above the selection window.



For many products you also have the option of downloading CAD or 2D drawings of the selected product version. Click the **CAD** tab for this and select the desired file type using picklists.

---

### Scope of delivery

The scope of delivery comprises:

- Ordered version of assembly
- Operating Instructions

## Accessories

The following are the most important accessories available at the time this documentation was issued.

- For accessories not listed here, please contact your Service or Sales Center.

The following accessories can be ordered via the product structure (see ordering information):

- Weld-in adapter G1¼, straight, 35 mm, 1.4435 (AISI 316 L), safety nozzle
- Weld-in adapter G1¼, angled, 35 mm, 1.4435 (AISI 316 L), safety nozzle

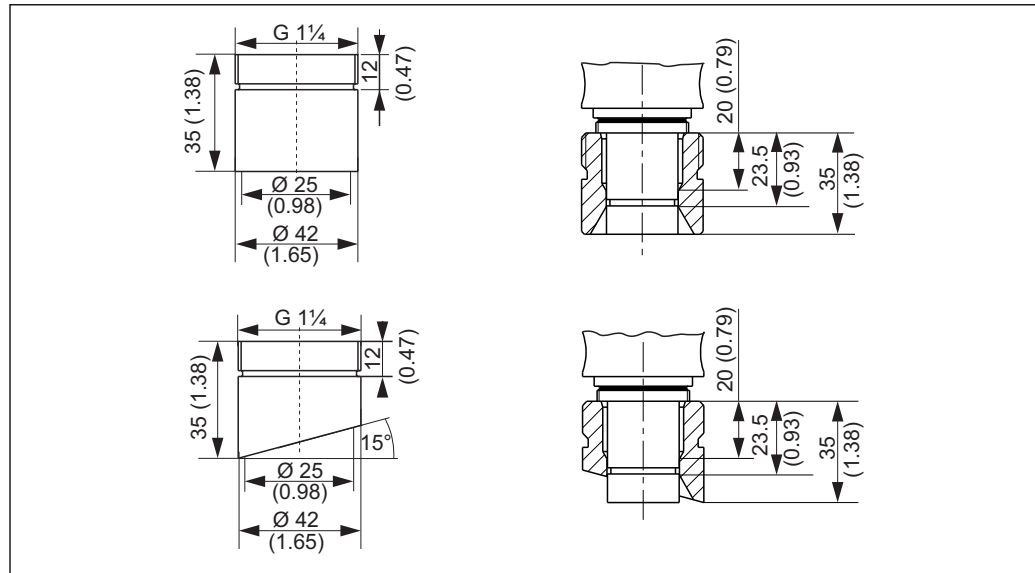

A0028744

23 Weld-in adapter (safety nozzle), dimensions in mm (in)

- Dummy plug G1¼, 1.4435 (AISI 316 L), FPM - FDA
- Sensor dummy 120 mm, 1.4435 (AISI 316 L), Ra = 0.38 µm
- Sensor dummy 225 mm, 1.4435 (AISI 316 L), Ra = 0.38 µm
- Sensor dummy 360 mm, 1.4435 (AISI 316 L), Ra = 0.38 µm
- Kit, seals for non-wetted parts
- Kit, FKM seals, G1¼, wetted parts
- Kit, FKM seals, immersion chamber version, wetted parts
- Kit, seal, wetted, EPDM
- Kit, seal, wetted, FKM
- Kit, seal, FFKM, basic, wetted
- Cable, plug-in, limit switch, M12, 5 m
- Cable, plug-in, limit switch, M12, 10 m
- Tool in case for installation/removal
- Output interface terminals, version: CPA871-620-R7  
NAMUR terminals for limit position switches
  - Operation of 8V DC feedback signals on 24V DC devices
  - Suitable for top-hat rail mounting

### Water filter and pressure reducer

#### Filter set CPC310, CVC400

- Water filter (dirt trap) 100 µm, complete, incl. angle bracket
- Order No. 71031661

#### Pressure reducer kit

- Complete, incl. manometer and angle bracket
- Order No. 51505755

### Hose nozzle

#### Hose connection set G¼, DN 12

- 1.4404 (AISI 316L) 2 x
- Order No. 51502808

#### Hose connection set G¼, DN 12

- PVDF (2 x)
- Order No. 50090491



**Flow vessels****Flow vessel**

- Flange DN 25 ISO 1092-2 PN16
- Material: stainless steel 1.4404 (AISI 316 L)

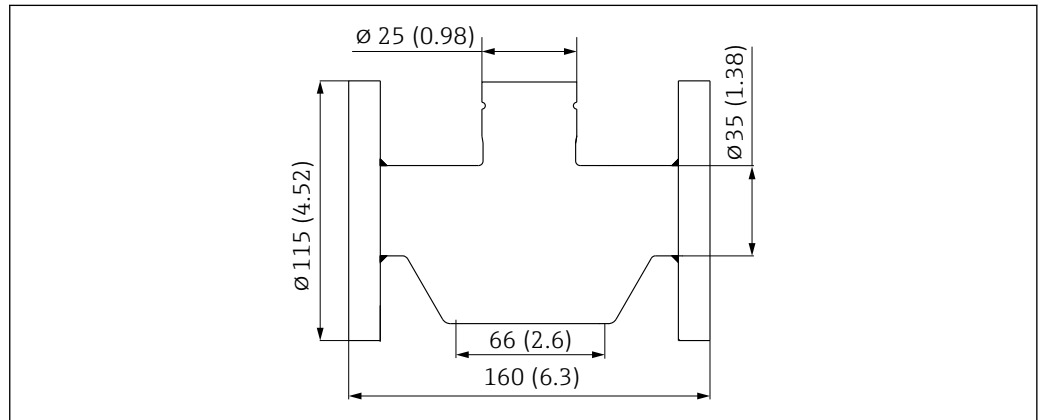

24 Dimensions in mm (in)

A0039147



Dummy plug available for maintenance purposes

**Cleaning systems****Air-Trol 500**

- Control unit for Cleanfit retractable assemblies
- Order No. 50051994



Technical Information TI00038C/07/EN

**Cleanfit Control CYC25**

- Converts electrical signals into pneumatic signals to control pneumatically-operated retractable assemblies or pumps in conjunction with Liquiline CM44x
- Wide range of control options
- Product Configurator on the product page: [www.endress.com/cyc25](http://www.endress.com/cyc25)



Technical Information TI01231C

**Liquiline Control CDC90**

- Fully automatic cleaning and calibration system for pH and ORP measuring points in all industries
- Cleaned, validated, calibrated and adjusted
- Product Configurator on the product page: [www.endress.com/cdc90](http://www.endress.com/cdc90)



Technical Information TI01340C

**Sensors****pH sensors****Orbisint CPS11D / CPS11**

- pH sensor for process technology
- Optional SIL version for connecting to SIL transmitter
- With dirt-repellent PTFE diaphragm
- Product Configurator on the product page: [www.endress.com/cps11d](http://www.endress.com/cps11d) or [www.endress.com/cps11](http://www.endress.com/cps11)



Technical Information TI00028C

**Memosens CPS31D**

- pH electrode with gel-filled reference system with ceramic diaphragm
- Product Configurator on the product page: [www.endress.com/cps31d](http://www.endress.com/cps31d)



Technical Information TI00030C

**Ceraliquid CPS41D / CPS41**

- pH electrode with ceramic junction and KCl liquid electrolyte
- Product Configurator on the product page: [www.endress.com/cps41d](http://www.endress.com/cps41d) or [www.endress.com/cps41](http://www.endress.com/cps41)



Technical Information TI00079C

**Ceragel CPS71D / CPS71**

- pH electrode with reference system including ion trap
- Product Configurator on the product page: [www.endress.com/cps71d](http://www.endress.com/cps71d) or [www.endress.com/cps71](http://www.endress.com/cps71)



Technical Information TI00245C

**Orbipore CPS91D / CPS91**

- pH electrode with open aperture for media with high dirt load
- Product Configurator on the product page: [www.endress.com/cps91d](http://www.endress.com/cps91d) or [www.endress.com/cps91](http://www.endress.com/cps91)



Technical Information TI00375C

**ORP sensors****Orbisint CPS12D / CPS12**

- ORP sensor for process technology
- Product Configurator on the product page: [www.endress.com/cps12d](http://www.endress.com/cps12d) or [www.endress.com/cps12](http://www.endress.com/cps12)



Technical Information TI00367C

**Ceraliquid CPS42D / CPS42**

- ORP electrode with ceramic junction and KCl liquid electrolyte
- Product Configurator on the product page: [www.endress.com/cps42d](http://www.endress.com/cps42d) or [www.endress.com/cps42](http://www.endress.com/cps42)



Technical Information TI00373C

**Ceragel CPS72D / CPS72**

- ORP electrode with reference system including ion trap
- Product Configurator on the product page: [www.endress.com/cps72d](http://www.endress.com/cps72d) or [www.endress.com/cps72](http://www.endress.com/cps72)



Technical Information TI00374C

**pH ISFET sensors****Tophit CPS441D / CPS441**

- Sterilizable ISFET sensor for low-conductivity media
- Liquid KCl electrolyte
- Product Configurator on the product page: [www.endress.com/cps441d](http://www.endress.com/cps441d) or [www.endress.com/cps441](http://www.endress.com/cps441)



Technical Information TI00352C

**Tophit CPS471D / CPS471**

- Sterilizable and autoclavable ISFET sensor for food and pharmaceuticals, process engineering
- Water treatment and biotechnology
- Product Configurator on the product page: [www.endress.com/cps471d](http://www.endress.com/cps471d) or [www.endress.com/cps471](http://www.endress.com/cps471)



Technical Information TI00283C

**Tophit CPS491D / CPS491**

- ISFET sensor with open aperture for media with high dirt load
- Product Configurator on the product page: [www.endress.com/cps491d](http://www.endress.com/cps491d) or [www.endress.com/cps491](http://www.endress.com/cps491)



Technical Information TI00377C

### pH and ORP combined sensors

#### **Memosens CPS16D**

- Combined pH/ORP sensor for process technology
- With dirt-repellent PTFE diaphragm
- With Memosens technology
- Product Configurator on the product page: [www.endress.com/cps16D](http://www.endress.com/cps16D)



Technical Information TI00503C

#### **Memosens CPS76D**

- Combined pH/ORP sensor for process technology
- Hygienic and sterile applications
- With Memosens technology
- Product Configurator on the product page: [www.endress.com/cps76d](http://www.endress.com/cps76d)



Technical Information TI00506C

#### **Memosens CPS96D**

- Combined pH/ORP sensor for chemical processes
- With poison-resistant reference with ion trap
- With Memosens technology
- Product Configurator on the product page: [www.endress.com/cps96d](http://www.endress.com/cps96d)



Technical Information TI00507C

### Conductivity sensor

#### **Memosens CLS82D**

- Four-electrode sensor
- With Memosens technology
- Product Configurator on the product page: [www.endress.com/cls82d](http://www.endress.com/cls82d)



Technical Information TI01188C

### Oxygen sensor

#### **Oxymax COS22D / COS22**

- Sterilizable sensor for dissolved oxygen
- With Memosens technology or as an analog sensor
- Product Configurator on the product page: [www.endress.com/cos22d](http://www.endress.com/cos22d) or [www.endress.com/cos22](http://www.endress.com/cos22)



Technical Information TI00446C

[www.addresses.endress.com](http://www.addresses.endress.com)

---