

Operating Instructions

Cleanfit CPA450

Retractable assembly for 12mm sensors for pH/ORP and oxygen measurement

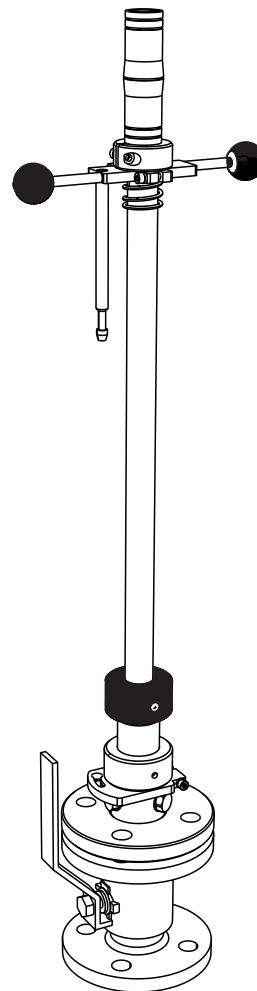





Table of contents







1	About this document	4	9.3	Mechanical construction	37
1.1	Warnings	4	Index		38
1.2	Symbols used	4			
1.3	Symbols on the device	4			
2	Basic safety instructions	5			
2.1	Requirements for personnel	5			
2.2	Designated use	5			
2.3	Occupational safety	5			
2.4	Operational safety	6			
2.5	Product safety	6			
3	Incoming acceptance and product identification	7			
3.1	Incoming acceptance	7			
3.2	Product identification	8			
3.3	Scope of delivery	8			
3.4	Certificates and approvals	9			
4	Installation	10			
4.1	Installation conditions	10			
4.2	Installation	13			
4.3	Post-installation check	18			
5	Operation options	19			
5.1	Initial commissioning	19			
5.2	Operating elements	19			
5.3	Operating the assembly	20			
6	Maintenance	22			
6.1	Cleaning the assembly	22			
6.2	Cleaning agent	23			
6.3	Replacing seals	24			
7	Repair	27			
7.1	Spare parts	28			
7.2	Return	31			
7.3	Disposal	31			
8	Accessories	32			
8.1	Accessory kits	32			
8.2	Welding socket	32			
8.3	Safety kit	32			
8.4	Sensors	33			
8.5	Connection accessories	34			
9	Technical data	36			
9.1	Environment	36			
9.2	Process	36			

1 About this document

1.1 Warnings

Structure of information	Meaning
 DANGER Causes (/consequences) If necessary, Consequences of non-compliance (if applicable) <ul style="list-style-type: none"> ▶ Corrective action 	This symbol alerts you to a dangerous situation. Failure to avoid the dangerous situation will result in a fatal or serious injury.
 WARNING Causes (/consequences) If necessary, Consequences of non-compliance (if applicable) <ul style="list-style-type: none"> ▶ Corrective action 	This symbol alerts you to a dangerous situation. Failure to avoid the dangerous situation can result in a fatal or serious injury.
 CAUTION Causes (/consequences) If necessary, Consequences of non-compliance (if applicable) <ul style="list-style-type: none"> ▶ Corrective action 	This symbol alerts you to a dangerous situation. Failure to avoid this situation can result in minor or more serious injuries.
NOTICE Cause/situation If necessary, Consequences of non-compliance (if applicable) <ul style="list-style-type: none"> ▶ Action/note 	This symbol alerts you to situations which may result in damage to property.

1.2 Symbols used

Symbol	Meaning
	Additional information, tips
	Permitted or recommended
	Not permitted or not recommended
	Reference to device documentation
	Reference to page
	Reference to graphic
	Result of a step

1.3 Symbols on the device

Symbol	Meaning
	Reference to device documentation

2 Basic safety instructions

2.1 Requirements for personnel

- Installation, commissioning, operation and maintenance of the measuring system may be carried out only by specially trained technical personnel.
- The technical personnel must be authorized by the plant operator to carry out the specified activities.
- The electrical connection may be performed only by an electrical technician.
- The technical personnel must have read and understood these Operating Instructions and must follow the instructions contained therein.
- Faults at the measuring point may only be rectified by authorized and specially trained personnel.

 Repairs not described in the Operating Instructions provided must be carried out only directly at the manufacturer's site or by the service organization.

2.2 Designated use

The assembly is designed exclusively for use in liquid media.

The manually operated Cleanfit CPA450 retractable assembly is designed for the installation of pH, ORP and oxygen sensors in vessels and pipelines.

Thanks to its design, it can be used in pressurized systems →  36.

Use of the device for any purpose other than that described, poses a threat to the safety of people and of the entire measuring system and is therefore not permitted.

The manufacturer is not liable for damage caused by improper or non-designated use.

2.3 Occupational safety

As the user, you are responsible for complying with the following safety conditions:

- Installation guidelines
- Local standards and regulations

2.4 Operational safety

Before commissioning the entire measuring point:

1. Verify that all connections are correct.
2. Ensure that electrical cables and hose connections are undamaged.
3. Do not operate damaged products, and protect them against unintentional operation.
4. Label damaged products as defective.

During operation:

- ▶ If faults cannot be rectified:
products must be taken out of service and protected against unintentional operation.

2.5 Product safety

2.5.1 State-of-the-art technology

The product is designed to meet state-of-the-art safety requirements, has been tested, and left the factory in a condition in which it is safe to operate. The relevant regulations and international standards have been observed.

3 Incoming acceptance and product identification

3.1 Incoming acceptance

1. Verify that the packaging is undamaged.
 - ↳ Notify the supplier of any damage to the packaging.
Keep the damaged packaging until the issue has been resolved.
2. Verify that the contents are undamaged.
 - ↳ Notify the supplier of any damage to the delivery contents.
Keep the damaged goods until the issue has been resolved.
3. Check that the delivery is complete and nothing is missing.
 - ↳ Compare the shipping documents with your order.
4. Pack the product for storage and transportation in such a way that it is protected against impact and moisture.
 - ↳ The original packaging offers the best protection.
Make sure to comply with the permitted ambient conditions.

If you have any questions, please contact your supplier or your local Sales Center.

3.2 Product identification

3.2.1 Nameplate

The nameplate provides you with the following information on your device:

- Order code
- Serial number
- Permitted pressure
- Permitted temperature

► Compare the information on the nameplate with the order.

3.2.2 Product identification

Product page

www.endress.com/cpa450

Interpreting the order code

The order code and serial number of your product can be found in the following locations:

- On the nameplate
- In the delivery papers

Obtaining information on the product

1. Go to www.endress.com.
2. Call up the site search (magnifying glass).
3. Enter a valid serial number.
4. Search.
 - ↳ The product structure is displayed in a popup window.
5. Click on the product image in the popup window.
 - ↳ A new window (**Device Viewer**) opens. All of the information relating to your device is displayed in this window as well as the product documentation.

3.2.3 Manufacturer's address

Endress+Hauser Conducta GmbH+Co. KG
Dieselstraße 24
D-70839 Gerlingen

3.3 Scope of delivery

The scope of delivery comprises:

- Assembly in the version ordered
- PAL mounting kit
- Hook wrench
- Operating Instructions

3.4 Certificates and approvals

3.4.1 CE/PED

The assembly has been manufactured according to good engineering practice as per Article 4, Paragraph 3 of the Pressure Equipment Directive 2014/68/EU and is therefore not required to bear the CE label.

3.4.2 EAC

The product has been certified according to guidelines TP TC 004/2011 and TP TC 020/2011 which apply in the European Economic Area (EEA). The EAC conformity mark is affixed to the product.

4 Installation

4.1 Installation conditions

4.1.1 Dimensions and process connections

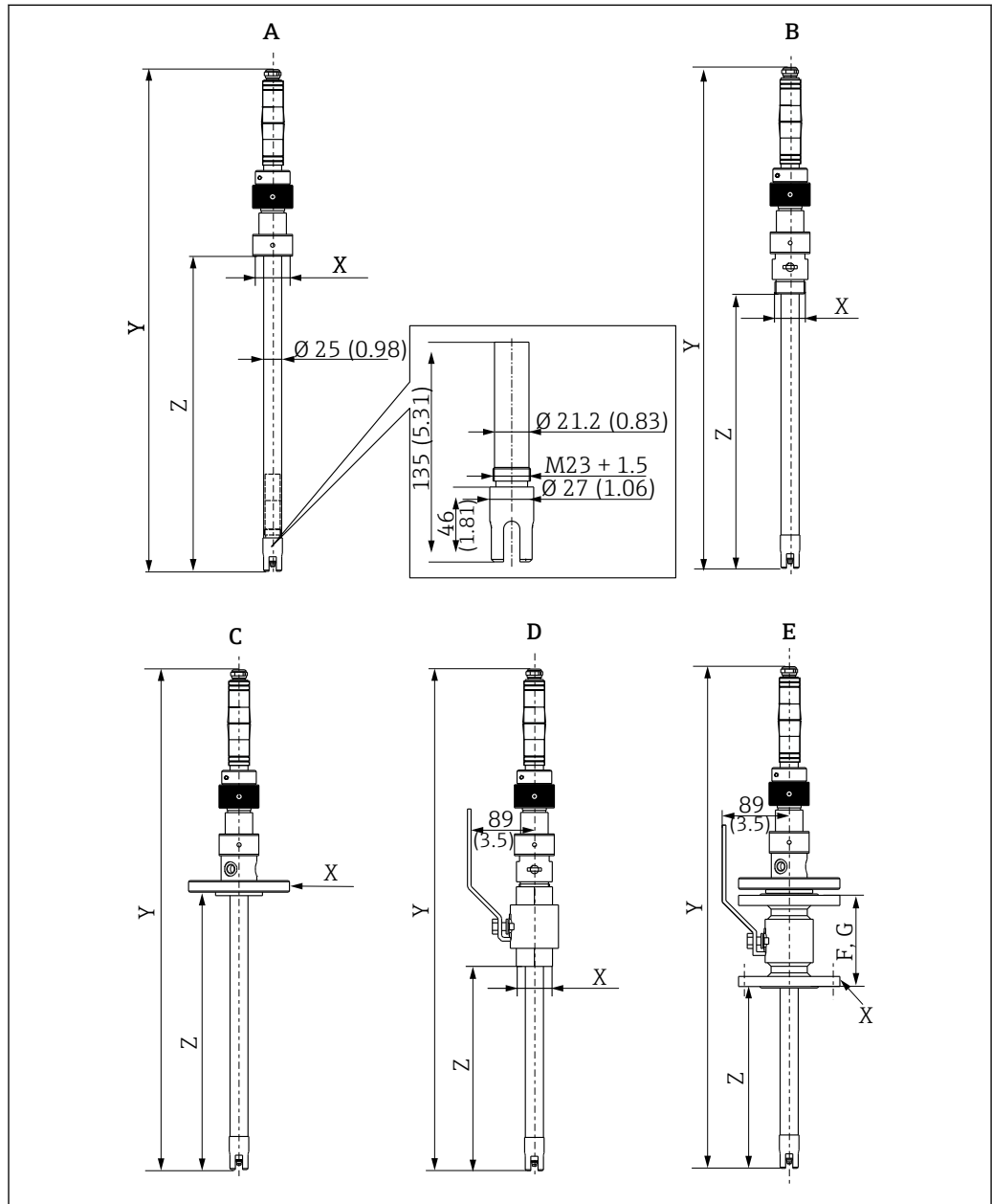

A0037726

1 Dimensions (see the following table). Engineering unit in mm (inch)

F 130 mm (5.12 in) (flange DN32)

G 140 mm (5.51 in) (flange ANSI 1¼")

Type	Assembly	Immersion depth mm (inch)	X Adapter	Y mm (inch)	Z mm (inch)
A	CPA450-*A***	100 (3.94) 250 (9.84) 700 (27.5)	G1½ internal	558 (21.97) 708 (27.87) 1158 (45.59)	275 (10.83) 425 (16.7) 875 (34.5)
B	CPA450-*B***	100 (3.94) 250 (9.84) 700 (27.5)	G1¼ external	558 (21.97) 708 (27.87) 1158 (45.59)	220 (9.06) 370 (14.9) 820 (32.6)
B	CPA450-*C***	100 (3.94) 250 (9.84) 700 (27.5)	NPT 1¼" external	558 (21.97) 708 (27.87) 1158 (45.59)	220 (9.06) 370 (14.9) 820 (32.6)
C	CPA450-*D***	100 (3.94) 250 (9.84) 700 (27.5)	Flange DN32 (as per DIN EN 1092-1)	558 (21.97) 708 (27.87) 1158 (45.59)	225 (8.86) 375 (14.76) 825 (32.48)
C	CPA450-*E***	100 (3.94) 250 (9.84) 700 (27.5)	Flange ANSI 1¼" (as per ASME B16.5)	558 (21.97) 708 (27.87) 1158 (45.59)	225 (8.86) 375 (14.76) 825 (32.48)
D	CPA450-*F***	100 (3.94) 250 (9.84) 700 (27.5)	G1¼ internal	558 (21.97) 708 (27.87) 1158 (45.59)	130 (5.12) 280 (11.2) 730 (28.7)
D	CPA450-*H***	100 (3.94) 250 (9.84) 700 (27.5)	NPT 1¼" external	558 (21.97) 708 (27.87) 1158 (45.59)	130 (5.12) 280 (11.2) 730 (28.7)
E	CPA450-*I***	100 (3.94) 250 (9.84) 700 (27.5)	Flange DN32 (as per DIN EN 1092-1)	558 (21.97) 708 (27.87) 1158 (45.59)	92 (3.62) 242 (9.53) 792 (31.18)
E	CPA450-*K***	100 (3.94) 250 (9.84) 700 (27.5)	Flange ANSI 1¼" (as per ASME B16.5)	558 (21.97) 708 (27.87) 1158 (45.59)	82 (3.23) 232 (9.13) 782 (30.79)
B	CPA450-*M*** and CPA450-*Q***	100 (3.94) 250 (9.84) 700 (27.5)	M-NPT 1½ external	558 (21.97) 708 (27.87) 1158 (45.59)	220 (8.66) 370 (14.57) 820 (32.28)
C	CPA450-*N*** and CPA450-*R***	100 (3.94) 250 (9.84) 700 (27.5)	Flange ANSI 2" (as per ASME B16.5)	558 (21.97) 708 (27.87) 1158 (45.59)	225 (8.86) 375 (14.76) 825 (32.48)

4.1.2 Mounting instructions



Suitable sensors

The following sensors are suitable for installation in the assembly:

- Digital sensors with Memosens technology, length 120 mm (4.72")
- pH/ORP glass electrodes, length 120 mm (4.72")
- ISFET sensors: Only the ISFET sensors specified in the "Accessories" section can be installed.
- Oxygen sensors, length 120 mm (4.72")

Orientation

The permitted orientation of the assembly depends on the sensor used:

- Digital sensors with Memosens technology, pH/ORP glass electrodes:
Install the assembly at an angle of at least 15° to the horizontal →  2,  12.
- ISFET sensors:
For ISFET sensors, there are basically no restrictions regarding orientation. The installation angle should be from 0 to 180°.
- All other sensors:
Pay attention to the information in the relevant TI.

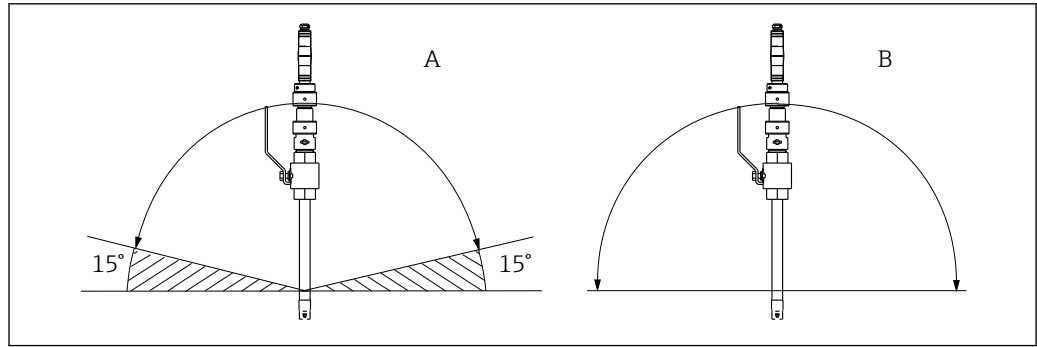

A0011679

2 Orientations

- A Glass sensors: 15° to the horizontal
- B ISFET sensors: 0 to 180° recommended

Insert the immersion assembly into the vessel or pipe to a depth that will ensure that medium continuously washes around the electrode, even at the minimum level.

Installing with a ball valve

To replace the sensor without interrupting the process, a ball valve is required. Depending on the version, the ball valve forms part of the assembly or must be installed by the customer.

CAUTION

There is a risk of injury if used without a ball valve. due to the risk of medium escaping.

- ▶ If used without a ball valve, the process must be stopped prior to dismantling the immersion tube or replacing the sensor.

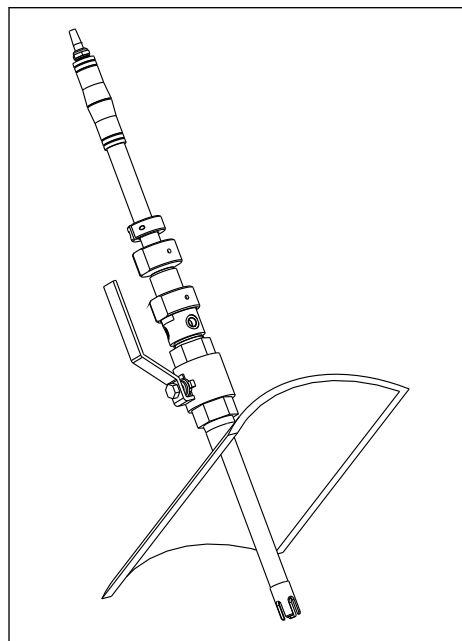

A0010209

3 Measuring mode (ball valve is open): assembly is retracted

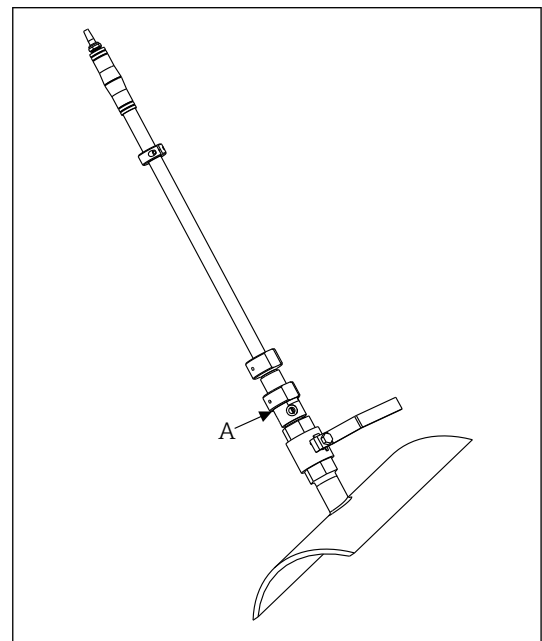

A0010210

4 Service position (ball valve is closed): assembly is extended for electrode replacement, calibration, rinsing

A Top edge of adapter

i Depending on the assembly version, a mounting clearance of at least 700 or 1150 mm (27.6" or 45.3") is required from the top edge of the adapter.

4.2 Installation

⚠ WARNING

If process medium and cleaning medium escape, there is a risk of injury due to high pressure, high temperatures or chemicals.

- ▶ Wear protective gloves, protective goggles and protective clothing.
- ▶ Mount the assembly only if vessels or pipes are empty and unpressurized.
- ▶ Before exposing the assembly to the process pressure, verify that all connections are sealed.

4.2.1 Measuring system

A complete measuring system comprises:

- Assembly Cleanfit CPA450
- Oxygen/pH/ORP electrode, length 120 mm (4.72"), e.g. Orbisint CPS11D
- Transmitter, e.g. Liquiline CM44x or Liquiline CM42
- measuring cable, e.g. CYK10

Optional:

- Junction box M12 socket/cable or cable/cable → 32
- Extension cable CYK11

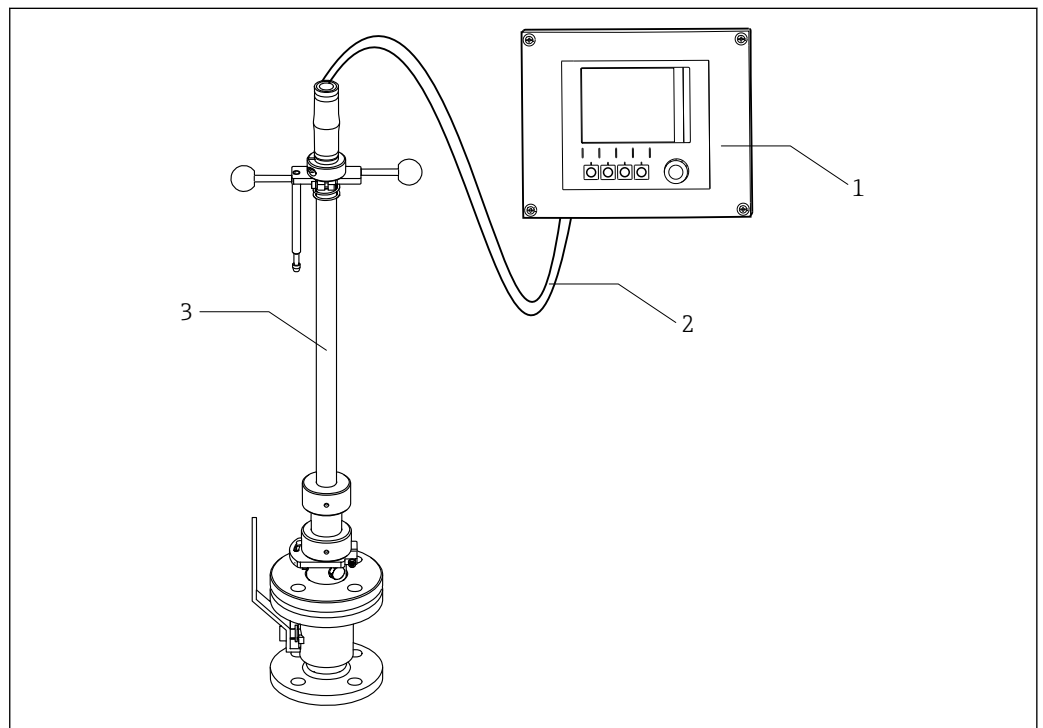

5 Measuring system with CPA450

- 1 Transmitter Liquiline CM44x
- 2 Measuring cable CYK10
- 3 Assembly Cleanfit CPA450

4.2.2 Required tools

The following tools are required for installing the assembly in the process and for installing the sensor:

- Allen key M5 (5 mm)
- Hook wrench AF 55 (included in scope of delivery)
- Combination wrench AF 20 (20 mm (0.79")) or adjustable open-ended wrench
- Adjustable open-ended wrench (up to 45 mm (1.8"))
- Open-ended wrench set (only for flange connection)

4.2.3 Installing the safety kit

i At pressures over 4 bar (58 psi) the use of a safety kit is strongly recommended.

⚠ DANGER

Non-compliance with the safety instructions can lead to injury or death.

- ▶ The safety instructions must be read and followed.
- ▶ Install the safety equipment only if the assembly has been removed.

i The safety equipment is **not** a substitute for the standard retainer of the assembly.

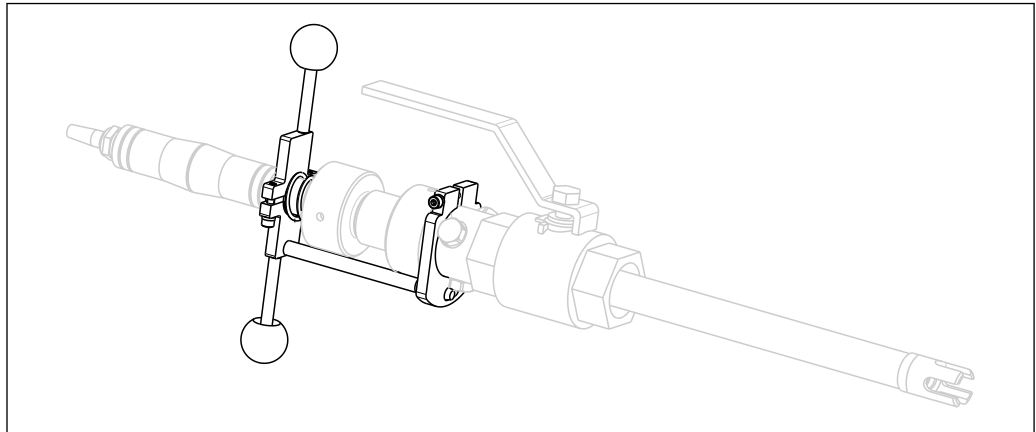

A0014680

6 Assembly with safety kit

Preparation

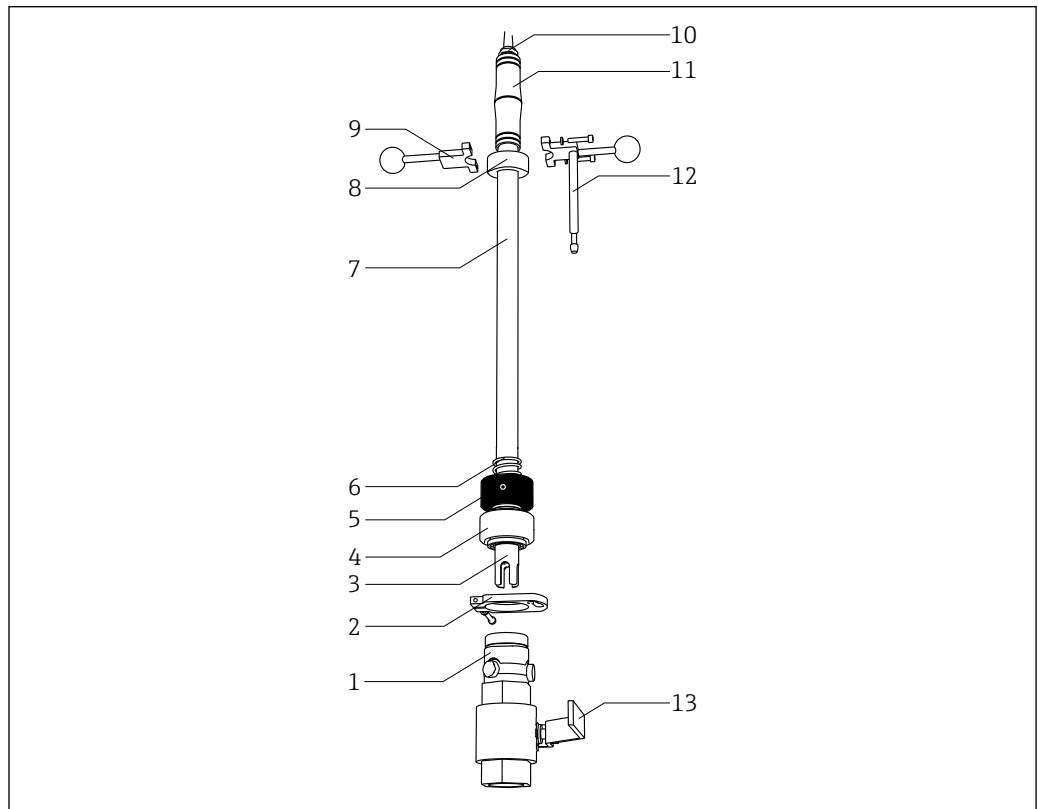

A0014681

7 Installing the safety kit

1 Service chamber

8 Setting collar

2	Safety kit (lower part)	9	Safety kit (upper part with handle)
3	Sensor holder with protection guard	10	Cable protector
4	Locking ring (metal)	11	Handle on immersion tube
5	Coupling nut (black)	12	Safety kit (upper part with handle and locking pin)
6	Safety kit (compression spring)	13	Ball valve with handle
7	Immersion tube		

1. Move the assembly to the measuring position, and mark the immersion tube approx. 20 mm (0.8") above the coupling nut (black) (item 5).
 - ↳ This is where the upper part of the safety kit (item 9) will be installed.
2. Use the hook wrench to open the coupling nut (black) by ¼ to ½ turn.
3. Pull the immersion tube out as far as the stop (service position).
4. Screw on the locking ring (item 4), and disconnect the assembly from the service chamber (item 1).

Installing the safety kit

1. Remove the cable protector (item 10).
 2. Unscrew the sensor holder (item 3).
 3. Unscrew the immersion tube handle (item 11).
 4. Remove the setting collar (item 8).
 5. Slide the compression spring (item 6) onto the immersion tube.
 6. Screw on both of the upper parts of the safety kit (items 9 and 10) at the marked position. Tighten both screws with a torque of 3.5 Nm (2.6 lbf ft).
 7. Install the setting collar.
 8. Screw the sensor holder onto the immersion tube.
 9. Mount the lower part of the safety kit (item 2) on the service chamber.
-  The side with the chamfered edge points towards the ball valve. Secure the lower part with a torque of 3.5 Nm (2.6 lbf ft).
10. Assemble the assembly.

4.2.4 Installing the assembly in the process

i In the case of versions with a pre-installed safety kit, it is still necessary to finalize the position of the safety kit →  14.

1. Move the assembly to the service position.
2. Secure the assembly to the vessel or piping using the process connection.

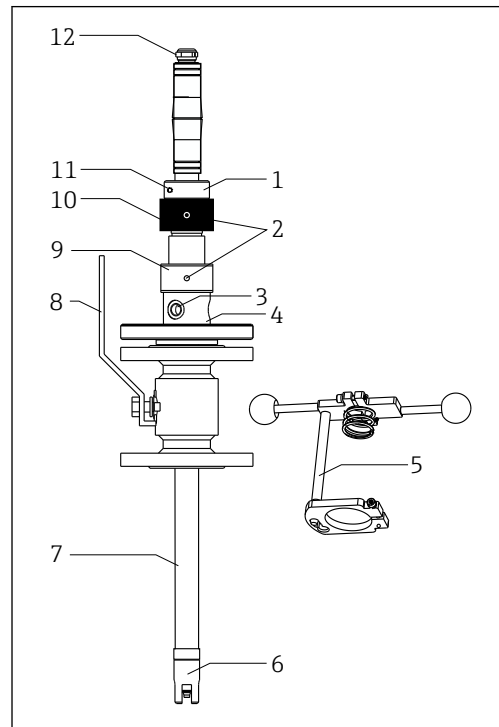

- 1 Setting collar for setting the immersion depth
- 2 Bore hole for hook wrench
- 3 Rinse connection G $\frac{1}{4}$ (316L) NPT $\frac{1}{4}$ " (Alloy C22 or titanium)
- 4 Service chamber
- 5 Safety kit
- 6 Sensor holder with protection guard
- 7 Immersion tube
- 8 Lever for opening/closing the ball valve
- 9 Locking ring (metal)
- 10 Coupling nut (black)
- 11 Allen screw M5 / AF4
- 12 Cable protector/cable gland

 8 Assembly in operational state (ball valve open)

4.2.5 Rinse water connection (optional)

NOTICE

Operating the service chamber with water pressures above 6 bar (87 psi) will damage the assembly.

- ▶ At water pressures above 6 bar (87 psi), including short pressure surges, install a pressure-reducing valve upstream.

1. Connect the rinse water line to the rinsing nozzle provided. The three rinsing nozzles at the assembly are identical (G $\frac{1}{4}$ for 316L material - NPT $\frac{1}{4}$ " for Alloy C22 and titanium).
2. Operate the rinse water connection of the assembly with a water pressure from 2 bar to max. 6 bar (29 to 87 psi).

i In addition to water, other or additional cleaning solutions can be used as rinse liquids. The specifications regarding the material resistance of the assembly and the permitted temperatures or pressures must be complied with.

You can also connect a drain valve or a manometer. These are available along with other accessories.

4.2.6 Sensor installation

⚠ WARNING

Risk of injury from high pressure, high temperature or chemical hazards if process medium escapes.

- ▶ Wear protective gloves, protective goggles and protective clothing.
- ▶ Clean or rinse the rinse chamber.
- ▶ Mount the assembly only if vessels or pipes are empty and unpressurized.
- ▶ Before subjecting the assembly to the process pressure, verify that all connections are sealed.

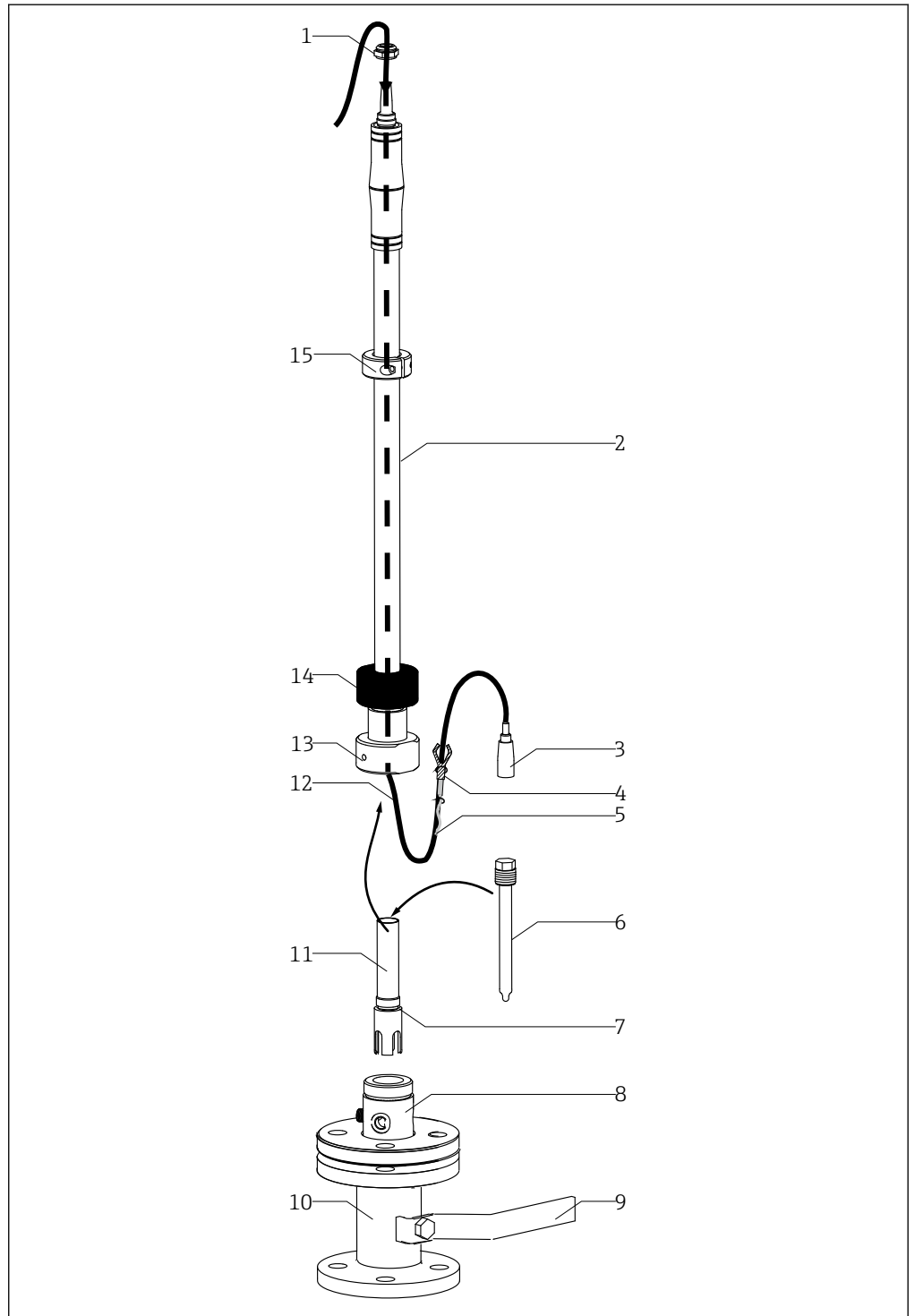

9 Cable entry and sensor installation

A0010212

⚠ CAUTION

The immersion tube may move suddenly and cause injuries.

- ▶ Hold the immersion tube with one hand.

Preparing the assembly

1. Use the hook wrench to carefully open the coupling nut (black) (item 14) by $\frac{1}{4}$ to $\frac{1}{2}$ turn.
2. Release the cable protector (item 1).
3. Pull the immersion tube (item 2) out as far as it will go.
4. Close the ball valve (item. 9).

Guiding the cable through and installing the sensor

1. Screw on the locking ring (metal) (item 13) using the hook wrench.
2. Remove the assembly from the ball valve.
3. Unscrew the sensor holder with integrated protection guard (item 11).
4. Guide the measuring cable (item 12) from below through the pipe to the transmitter connection.
5. If necessary, attach the PAL contact spring (item 4) to the contact cable (item 5).
6. Secure the spring with two cable ties.
7. Screw the sensor (item 6) into the sensor holder (item 11).
8. Attach the cable connector (item 3) to the sensor (item 6).
9. Ensure that the O-ring (item 7) is installed at the end of the thread.
10. Insert the sensor holder (item 11) into the immersion tube as far as it will go, and screw it tight by hand.
11. Reattach the cable protector.

Assembling the assembly

1. Re-install the assembly on the ball valve (item 10).
2. Screw on the locking ring (metal) (item 13), and tighten with the hook wrench.
3. Ensure that the coupling nut (black) (item 14) is opened only by a $\frac{1}{2}$ turn.
4. Position the setting collar (item 15) at the desired immersion depth, and secure with an Allen key.
5. Open the ball valve (item 9).
6. Insert the immersion tube as far as the stop on the setting collar (item 15).
7. Tighten the coupling nut (black) (item 14) using the hook wrench.
8. Secure the coupling nut (black) by an additional $\frac{1}{8}$ turn (45° , corresponds to 10 to 15 Nm (7 to 11 lbf ft)).

4.3 Post-installation check

1. After mounting, check all the connections to ensure they are secure and leak-tight.
2. Ensure that the hose of the (optional) rinse water connections cannot be removed without force. This pipe is in open contact with the medium and must be secured accordingly.
3. Check the hoses for damage.

5 Operation options

5.1 Initial commissioning

Prior to commissioning, ensure that:

- all seals are correctly seated (on the assembly and on the process connection)
- the sensor is correctly installed and connected
- the water connection at the rinse connections is correct (if present).

⚠ WARNING

Risk of injury from high pressure, high temperature or chemical hazards if process medium escapes.

- ▶ Wear protective gloves, protective goggles and protective clothing.
- ▶ Mount the assembly only if vessels or pipes are empty and unpressurized.
- ▶ Before subjecting the assembly to the process pressure, verify that all connections are sealed.

5.2 Operating elements

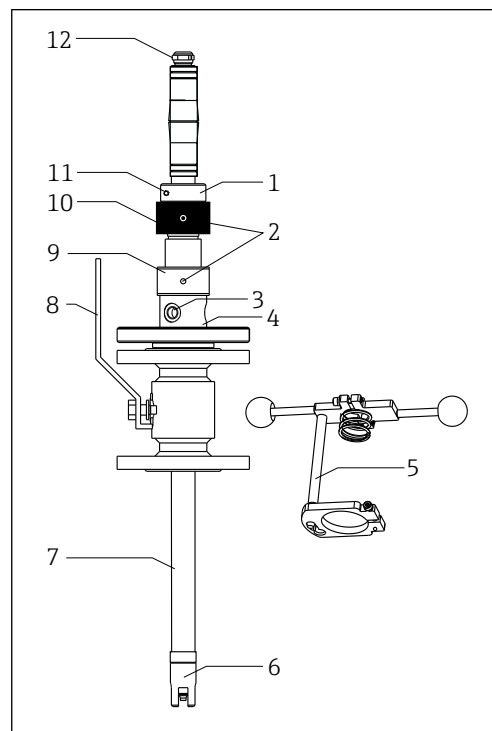

- 1 Setting collar for setting the immersion depth
- 2 Bore hole for hook wrench
- 3 Rinse connection G $\frac{1}{4}$ (316L) NPT $\frac{1}{4}$ " (Alloy C22 or titanium)
- 4 Service chamber
- 5 Safety kit
- 6 Sensor holder with protection guard
- 7 Immersion tube
- 8 Lever for opening/closing the ball valve
- 9 Locking ring (metal)
- 10 Coupling nut (black)
- 11 Allen screw M5
- 12 Cable protector

 10 Operating elements

The following operating options are available:

- Setting collar (item 1)
For setting the desired immersion depth of the assembly. Alternatively, the safety kit can be used.
- Coupling nut (black) (item 10).
For locking the assembly in the desired position.
- Locking ring (metal) (item 9)
For securing the assembly on the ball valve.

- Lever (item 8)
For opening or closing the ball valve.
- Immersion tube (item 7)
The desired orientation of the sensor is configured by turning the immersion tube.
- Stop/sensor holder (item 6)
When moving the assembly to the service position, pull the immersion tube out as far as this stop.

5.3 Operating the assembly

NOTICE

Injuries due to the presence of process medium in the service chamber

- ▶ Clean the service chamber and drain off medium.

 While it is moving, the process pressure must not exceed 4 bar (58 psi). If the assembly is secured by means of the safety kit, the pressure may be increased.

Moving from the service position to the measuring position

1. Open the coupling nut (black) using the hook wrench.
2. Open the ball valve.
3. Push the immersion tube pipe in the direction of the process as far as the stop.
4. Secure the coupling nut (black) on the immersion tube until it is hand-tight. To do so, use the hook wrench and secure the coupling nut (black) by an additional 1/8 turn (45°, corresponds to 10 to 15 Nm (7 to 11 lbf ft)).
 - ↳ The immersion tube cannot accidentally return to the service position.

 When using the safety kit, screw the coupling nut (black) onto the immersion tube until it is hand-tight.

Moving from the measuring position to the service position

CAUTION

The immersion tube may move suddenly and cause injuries.

- ▶ Hold the immersion tube with one hand.
1. Use the hook wrench to carefully open the coupling nut (black) by ¼ to ½ turn.
 2. Pull the immersion tube out as far as the stop (service position).
 3. Close the ball valve.
 - ↳ The lever is horizontal.

5.3.1 Operating the safety kit (optional)

Locking operation

1. Carefully open the ball valve. Ensure that the coupling nut (black) is not tightened.
2. Push the handles towards the ball valve, turning them counterclockwise.
 - ↳ The locking pin is locked.
3. Tighten the coupling nut (black) using the hook wrench.

Unlocking operation

1. Release the coupling nut (black) using the hook wrench.
2. Push the handles towards the ball valve, turning them clockwise.
 - ↳ The locking pin is unlocked.
3. Move the assembly to the service position.
4. Close the ball valve.

6 Maintenance

WARNING

Risk of injury due to escaping medium, high pressure and high temperature.

- ▶ Before each maintenance task, ensure that the process pipe or vessel is unpressurized, empty and rinsed.
- ▶ Move the assembly to the service position, and close the ball valve.

6.1 Cleaning the assembly

For stable and safe measurements:

- ▶ Clean the assembly and sensor regularly. The frequency and intensity of the cleaning process depend on the medium.

All parts in contact with the medium, such as the sensor and the sensor guide, must be cleaned regularly.

1. Remove the sensor in the reverse order to installation.
2. Remove light dirt and fouling with suitable cleaning solutions. (→  23)
3. Remove heavy soiling using a soft brush and a suitable cleaning agent.
4. For very persistent dirt, soak the parts in a cleaning solution. Then clean the parts with a brush.

 A typical example of a cleaning interval would be 6 months in the case of drinking water.

 Apply grease to dry O-rings to ensure that the assembly is properly sealed, particularly the sensor holder O-rings.

6.2 Cleaning agent

⚠ WARNING

Organic solvents containing halogens

Limited evidence of carcinogenicity! Dangerous for the environment with long-term effects!

- ▶ Do not use organic solvents that contain halogens.

⚠ WARNING

Thiocarbamide

Harmful if swallowed! Limited evidence of carcinogenicity! Possible risk of harm to the unborn child! Dangerous for the environment with long-term effects!

- ▶ Wear protective goggles, protective gloves and appropriate protective clothing.
- ▶ Avoid all contact with the eyes, mouth and skin.
- ▶ Avoid discharge into the environment.

The most common types of soiling and the cleaning agents used in each case are shown in the following table.

Type of soiling	Cleaning agent
Greases and oils	Hot water or tempered (alkaline) agents containing surfactants or water-soluble organic solvents (e. g. ethanol)
Limescale deposits, metal hydroxide buildup, lyophobic biological buildup	Approx. 3% hydrochloric acid
Sulfide deposits	Mixture of 3% hydrochloric acid and thiocarbamide (commercially available)
Protein buildup	Mixture of 3% hydrochloric acid and pepsin (commercially available)
Fibers, suspended substances	Pressurized water, possibly surface-active agents
Light biological buildup	Pressurized water

- ▶ Choose a cleaning agent to suit the degree and type of soiling.

6.3 Replacing seals

WARNING

Risk of medium escaping!

- ▶ Seals must be replaced only by authorized, specialized personnel.

CAUTION



Risk of injury due to residual medium and elevated temperatures

- ▶ When handling parts that are in contact with the medium, protect against residual medium and elevated temperatures.
- ▶ Wear protective goggles and safety gloves.

- Keep the sealing surfaces of the assembly free from dirt.
- Remove caking and buildup from time to time.

The following seals can be replaced:

- 2 O-rings of sensor holder
- 1 O-ring + 1 thrust collar of sensor
- 3 O-rings of flanged sleeve (version from 02/11)
- 2 O-rings of flanged sleeve (version up to 01/11)
- 1 flat seal of service chamber (only with flange connection)

 To lubricate the O-rings, grease (e.g. Klüber Syntheso Glep 1 or Paraliq GTE 703 silicon grease) and the appropriate tool (→  13) are required.

6.3.1 Procedure for replacing seals

Removing the assembly



- ▶ Disconnect the assembly from the process.

For versions without a ball valve:

1. Switch off the process.
2. Move the assembly to the service position.
3. Drain the pipeline or the vessel.
4. Open the locking ring (metal) using the hook wrench.
5. Remove the assembly from the process connection (welding socket or flange).

For versions with a ball valve:

1. Move the assembly to the service position.
2. Close the ball valve.
3. Open the locking ring (metal) using the hook wrench.
4. Remove the assembly from the ball valve and the adapter.

 Ordering information for O-ring kits →  28

Replacing the O-rings on the sensor and sensor holder

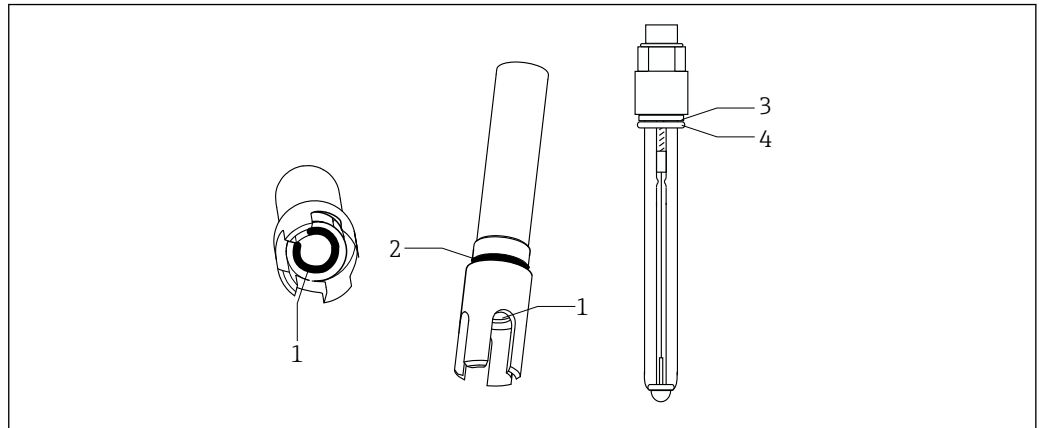

A0010204

1. Remove the cable protector at the top end of the assembly.
2. Unscrew the sensor holder from the assembly.
3. Unscrew the sensor from the sensor holder.
4. Lightly lubricate the O-rings.
5. Replace the O-ring (item 4, 10.69 x 3.53) and the thrust collar (item 3) on the sensor.
6. Replace the inner O-ring (item 1, 10.69 x 3.53) and the outer O-ring (item 2, 18.72 x 2.62) of the sensor holder.
7. Screw the sensor back into the holder.

Replacing the seals on the flanged sleeve

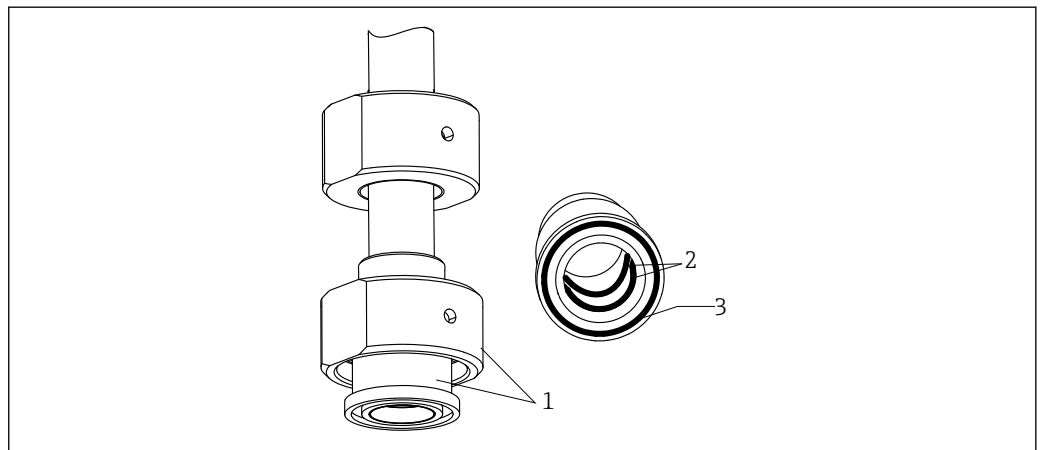

A0010205

1. Lightly lubricate the O-rings.
2. Slide the flanged sleeve including the locking ring (item 1) off the immersion tube.
3. Replace the inner O-ring (item 2, 24.99 x 3.53) and the outer O-ring (item 3, 32.92 x 3.53).
4. Slide the flanged sleeve with the locking ring (metal) back onto the immersion tube.

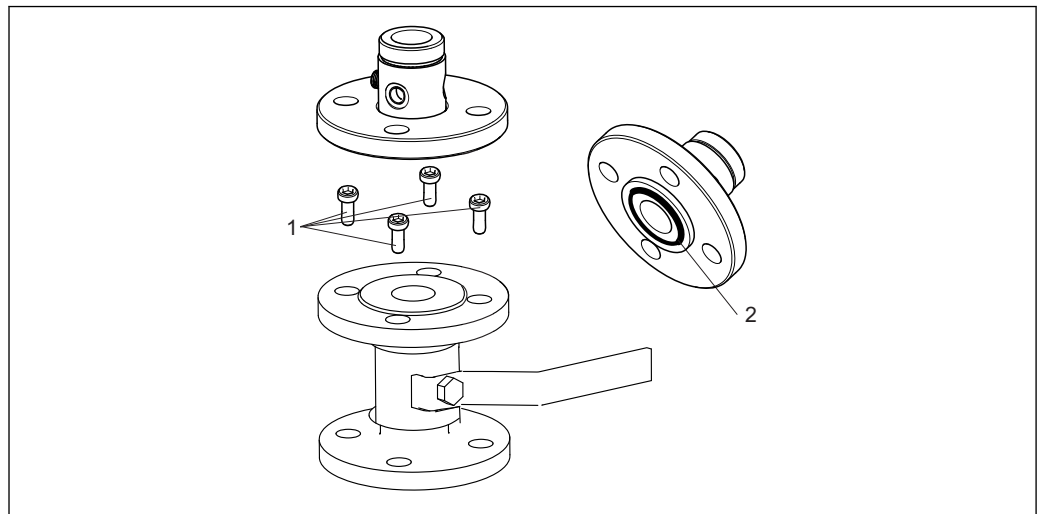
Replacing the flat seal of the adapter for flange connections (optional)

A0010206

1. Lightly lubricate the seal.
2. Release the screws between the flange and ball valve (item 1).
3. Remove the flange with the adapter from the ball valve, and replace the seal (item 2, 59 x 50 x 2).
4. Screw the flange with adapter back onto the ball valve, and tighten all of the screws.

Assembling the assembly

1. Screw the sensor holder back onto the immersion tube.
2. Attach the cable protector.
3. Place the assembly back onto the adapter, and tighten the locking ring (metal) using the hook wrench.
4. For assemblies with a ball valve, open the ball valve.
5. Move the assembly to the measuring position.
6. Check the assembly for leaks.

7 Repair

WARNING

Danger resulting from improper repair!

- ▶ Any damage to the assembly that compromises pressure safety must be repaired only by authorized and qualified personnel.
- ▶ Following each repair and maintenance task, check the assembly for leaks using appropriate procedures. Following this, the assembly must again comply with the specifications in the technical data.
- ▶ Replace all other damaged components immediately.

7.1 Spare parts

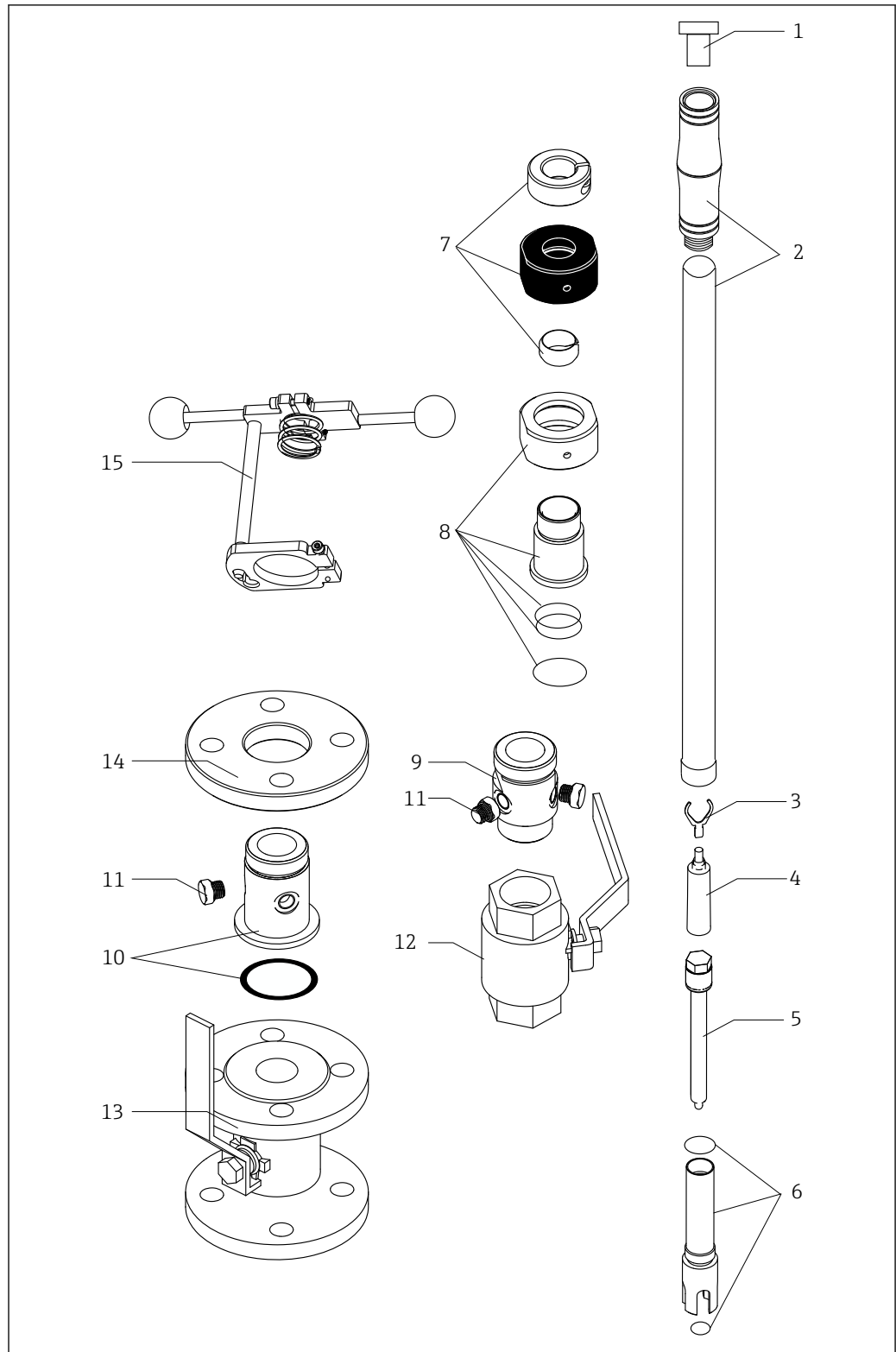

A0037952

11 Spare parts

Item No.	Description and contents	Order number of spare parts kit
	Seal set, EPDM	50090489
	Seal set, FPM, Viton	50090490

Item No.	Description and contents	Order number of spare parts kit
	Seal set, FFKM, Kalrez	71028925
1	Pressure screw / nozzle	51501523
2	Immersion tube 100 mm, 316L, cable gland; old version up to 01/11	71069820
	Immersion tube, 250 mm, 316L, cable gland; old version up to 01/11	51501521
	Immersion tube, 700 mm, 316L, cable gland; old version up to 01/11	51501522
	Immersion tube, 100 mm, 316L, with stop, without handle; version from 02/11	71128830
	Immersion tube, 250 mm, 316L, with stop, without handle; version from 02/11	71128831
	Immersion tube, 700 mm, 316L, with stop, without handle; version from 02/11	71128832
	Immersion tube, 100 mm, Alloy C22, with stop, without handle; version from 02/11	71128833
	Immersion tube, 250 mm, Alloy C22, with stop, without handle; version from 02/11	71128834
	Immersion tube, 700 mm, Alloy C22, with stop, without handle; version from 02/11	71128836
	Immersion tube, 100 mm, titanium, with stop, without handle; version from 02/11	71128837
	Immersion tube, 250 mm, titanium, with stop, without handle; version from 02/11	71128838
	Immersion tube, 700 mm, titanium, with stop, without handle; version from 02/11	71128839
	Kit CPA450, handle with thread 316L	71244830
	3	PAL mounting kit
4	Cable connector	
5	Sensor (not included in scope of delivery)	
6	Sensor holder with EPDM O-rings; version from 01/2005	51517804
	Sensor holder with Viton O-rings; version from 01/2005	51517805
	Sensor holder with Kalrez O-rings; version from 01/2005	71028949
7	Setting collar, clamping ring, coupling nut (black)	51501535
8	Flanged sleeve, locking ring, stainless steel 316L; EPDM O-rings	51501536
	Flanged sleeve, locking ring, stainless steel 316L; Viton O-rings	51501537
	Flanged sleeve, locking ring, stainless steel 316L; Kalrez O-rings	71028947
	Flanged sleeve, locking ring, Alloy C22; Kalrez O-rings; version from 02/2011	71128841
	Flanged sleeve, locking ring, titanium ; Kalrez O-rings; version from 02/2011	71128842
9	Adapter with 3 x rinse connection G 1¼, connection G 1¼ For assembly version: <ul style="list-style-type: none"> ▪ CPA450-xBxxx ▪ CPA450-xFxxx ▪ CPA450-xGxxx 	51501538
	Adapter with 3 x rinse connection G 1¼, connection NPT 1¼" For assembly version: <ul style="list-style-type: none"> ▪ CPA450-xCxxx ▪ CPA450-xHxxx 	51501539

Item No.	Description and contents	Order number of spare parts kit
10	Adapter with 3 x rinse connection G 1¼, EPDM, connection for flange For assembly version: <ul style="list-style-type: none"> ■ CPA450-xDxxx ■ CPA450-xExxx ■ CPA450-xLxxx ■ CPA450-xKxxx 	51501546
	Adapter with 3 x rinse connection G 1¼, Viton, connection for flange For assembly version: <ul style="list-style-type: none"> ■ CPA450-xDxxx ■ CPA450-xExxx ■ CPA450-xLxxx ■ CPA450-xKxxx 	51501547
	Adapter with 3 x rinse connection G 1¼, FFKM/Kalrez, connection for flange For assembly version: <ul style="list-style-type: none"> ■ CPA450-xDxxx ■ CPA450-xExxx ■ CPA450-xLxxx ■ CPA450-xKxxx 	71028946
11	Locking screws G ¼ stainless steel 1.4404 (AISI 316L) adapter (except for assembly version CPA450-xAxxx)	51501540
12	Ball valve G 1¼, stainless steel 1.4408 (AISI 316L) For assembly version: CPA450-xGxxx	51501542
	Ball valve NPT 1¼", stainless steel 1.4408 (AISI CF-8M) For assembly version: CPA450-xHxxx	51501543
13	Ball valve DN32 flange For assembly version: CPA450-xIxxx	51501548
	Ball valve ANSI 1¼" flange For assembly version: CPA450-xKxxx	51501549
14	Flange DN32 For assembly version: <ul style="list-style-type: none"> ■ CPA450-xDxxx ■ CPA450-xLxxx 	51501544
	Flange ANSI 1¼" For assembly version: <ul style="list-style-type: none"> ■ CPA450-xExxx ■ CPA450-xKxxx 	51501545
15	Safety kit	71098681

7.2 Return

The product must be returned if repairs or a factory calibration are required, or if the wrong product was ordered or delivered. As an ISO-certified company and also due to legal regulations, Endress+Hauser is obliged to follow certain procedures when handling any returned products that have been in contact with medium.

To ensure the swift, safe and professional return of the device:

- ▶ Refer to the website www.endress.com/support/return-material for information on the procedure and conditions for returning devices.

7.3 Disposal

The device contains electronic components. The product must be disposed of as electronic waste.

- ▶ Observe the local regulations.

8 Accessories

The following are the most important accessories available at the time this documentation was issued.

- ▶ For accessories not listed here, please contact your Service or Sales Center.

8.1 Accessory kits

Hose nozzles for rinse connections G ¼, DN 12

- Stainless steel 1.4404 (AISI 316 L) x 2
- Order number: 51502808

Hose nozzles for rinse connections G ¼, DN 12

- PVDF (2 x)
- Order number: 50090491

Manometer

- Mount in rinse connection to monitor process pressure
- 0 - 16 bar (0 to 232 psi); G¼
- Order number: 71082362

Drain ball valve

- for draining residual medium; G¼; stainless steel 1.4408 (AISI CF-8M)
- Order number: 71083041

Hook wrench DIN 1810 flat face

- D 58 - 68 mm
- Order number: 50090687

8.2 Welding socket

Welding socket G 1¼ straight

- for process connection F
- Dimensions: length 50 mm (1.97 in), Ø 42.6 mm (1.68 in)
- Material: stainless steel 1.4571 (AISI 316 Ti)
- Order number: 51502284

8.3 Safety kit

- Mechanical device for securing the measuring position
- For applications in dusty or sooty environments
- For applications involving vibrations or pressure surges
- Order number: 71098681

8.4 Sensors

8.4.1 Glass electrodes, analog and digital with Memosens technology

 When ordering sensors, please note that only electrode versions with a shaft length of 120 mm (4.72") and a diameter of 12 mm (0.47") are suitable for assembly CPA450. The most commonly used sensors are listed as follows.

Orbisint CPS11D / CPS11

- pH sensor for process technology
- With dirt-repellent PTFE diaphragm
- Product Configurator on the product page: www.endress.com/cps11d or www.endress.com/cps11

 Technical Information TI00028C

Orbisint CPS12D / CPS12

- ORP sensor for process technology
- Product Configurator on the product page: www.endress.com/cps12d or www.endress.com/cps12

 Technical Information TI00367C

Ceragel CPS71D / CPS71

- pH electrode with reference system including ion trap
- Product Configurator on the product page: www.endress.com/cps71d or www.endress.com/cps71

 Technical Information TI00245C

Ceragel CPS72D / CPS72

- ORP electrode with reference system including ion trap
- Product Configurator on the product page: www.endress.com/cps72d or www.endress.com/cps72

 Technical Information TI00374C

Orbipore CPS91D / CPS91

- pH electrode with open aperture for media with high dirt load
- Product Configurator on the product page: www.endress.com/cps91d or www.endress.com/cps91

 Technical Information TI00375C

8.4.2 ISFET sensors for CPA450

Memosens CPS47D

- Sterilizable and autoclavable ISFET sensor for pH measurement
- Refillable KCI liquid electrolyte
- Product Configurator on the product page: www.endress.com/cps47d

 Technical Information TI01412C

Memosens CPS77D

- Sterilizable and autoclavable ISFET sensor for pH measurement
- Product Configurator on the product page: www.endress.com/cps77d

 Technical Information TI01396

Memosens CPS97D

- ISFET sensor for pH measurement with long-term stability in media with high dirt loads
- Product Configurator on the product page: www.endress.com/cps97d



Technical Information TI01405C

8.4.3 Oxygen sensors

Oxymax COS22D

- Sterilizable sensor for dissolved oxygen
- With Memosens technology or as an analog sensor
- Product Configurator on the product page: www.endress.com/cos22d



Technical Information TI00446C

Memosens COS81D

- Sterilizable, optical sensor for dissolved oxygen
- With Memosens technology
- Product Configurator on the product page: www.endress.com/cos81d



Technical Information TI01201C

8.5 Connection accessories

CPK1

For pH/ORP electrodes with GSA plug-in head

Ordering information is available from your sales office or at www.endress.com.**Measuring cable CPK9**

- Terminated measuring cable for connecting analog sensors with TOP68 plug-in head
- Selection in accordance with product structure
- Ordering information: Endress+Hauser sales office or www.endress.com.

Measuring cable CPK12

- Terminated measuring cable for connecting analog ISFET sensors with TOP68 plug-in head
- Selection in accordance with product structure
- Ordering information: Endress+Hauser sales office or www.endress.com

Memosens data cable CYK10

- For digital sensors with Memosens technology
- Product Configurator on the product page: www.endress.com/cyk10



Technical Information TI00118C

Memosens data cable CYK11

- Extension cable for digital sensors with Memosens protocol
- Product Configurator on the product page: www.endress.com/cyk11



Technical Information TI00118C

Measuring cable CYK71

- Unterminated cable for connecting analog sensors and for extending sensor cables
- Sold by the meter, order numbers:
 - Non-Ex version, black: 50085333
 - Ex-version, blue: 50085673

Measuring cable CYK81

- Unterminated cable for extending sensor cables (e.g. Memosens, CUS31/CUS41)
- 2 x 2 cores, twisted with shielding and PVC sheath (2 x 2 x 0.5 mm² + shielding)
- Sold by meter, Order No.: 51502543

Junction box, cable/cable

- Material: aluminum, painted
- Cable extension: Memosens sensors, Liquiline
- Order No.: 71145499

Junction box, M12 socket/cable

- Material: aluminum, painted
- Cable extension: Memosens sensors, Liquiline
- Order No.: 71145498

VBA

- Junction box for cable extension
- 10 terminal strips
- Cable entries: 2 x Pg 13.5, 2 x Pg 16
- Material: polycarbonate
- Degree of protection: IP 65
- Order number: 50005276

9 Technical data

9.1 Environment

Ambient temperature 0 to 80 °C (32 to 176 °F)

Storage temperature 0 to 80 °C (32 to 176 °F)

9.2 Process

Process pressure max. 12 bar at 100 °C (175 psi at 212 °F)

i At pressures above 4 bar (58 psi) the use of a safety kit is strongly recommended.

Process temperature -15 to 130 °C (5 to 266 °F)

Pressure/temperature ratings

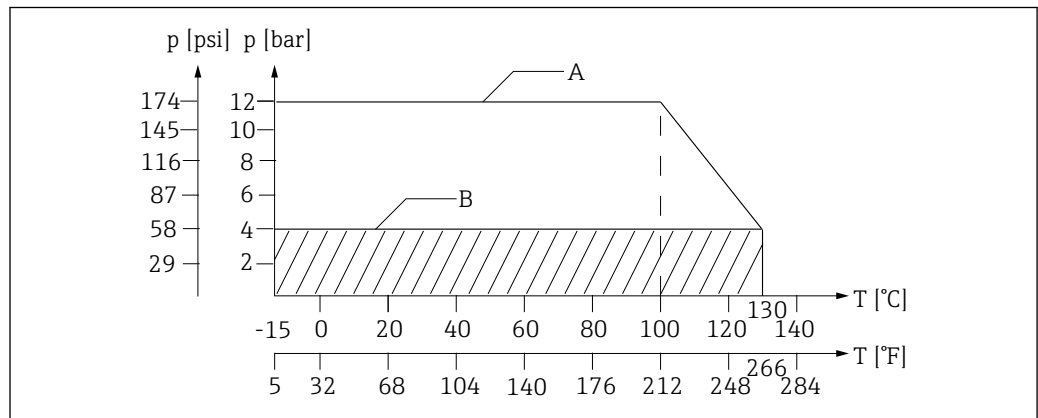

12 Pressure/temperature ratings

- A Maximum process pressure (static), only for fully installed assembly
- B Maximum pressure for moving the assembly (functional)

i Observe the maximum permitted process temperature and process pressure of the sensor.

9.3 Mechanical construction

Design, dimensions See →  10

Weight Depends on version:
 Without ball valve: 2 kg (4.41 lbs)
 With threaded ball valve: 5 kg (11 lbs)
 With flanged ball valve: 10 kg (22.1 lbs)

Materials

In contact with medium	
Immersion tube:	stainless steel 1.4404 (AISI 316 L), Alloy C22, titanium 3.7035
O-rings:	EPDM / Viton / Kalrez
Ball valve:	stainless steel 1.4404 or 1.4408 (AISI 316 L or CF-8M)
Ball valve seals:	PTFE

Not in contact with medium	
Screws:	stainless steel 1.4401 (AISI 316)
Coupling nut (black):	PA66GF
Clamping ring:	PEEK
Handle:	PVC
Cable protector:	thermoplastic elastomer (TPE)

Rinse connection nozzles For material 316L: 3 x G ¼
 For titanium or Alloy C22: 3 x NPT ¼"

Index

A

Accessories	32
Cable	34
Welding socket	32
Approvals	9

C

Certificates	9
Cleaning agent	23
Cleaning interval	22
Cleaning the assembly	22
Connection	
Rinse water	16

D

Designated use	5
Dimensions	10
Disposal	31

E

Environment	36
-----------------------	----

I

Incoming acceptance	7
Installation	10, 13
Orientation	11
Safety kit	14
Installation conditions	10

M

Maintenance	22
Mechanical construction	37
Mounting instructions	11

N

Nameplate	8
---------------------	---

O

O-rings	24
Operating elements	19
Operation	19
Measurement	20
Service	20
Operational safety	6
Orientation	11

P

Post-installation check	18
Pressure surges	16
Process pressure	36
Product identification	7

R

Repair	27
Replacement	
Damaged parts	27
Seals	24

Return	31
Rinse water connection	16

S

Safety instructions	5
Safety kit	14
Scope of delivery	8
Seals	24
Spare parts	28
Storage	7
Suitable sensors	10
Symbols	4

T

Technical data	36
Transport	7

U

Use	5
---------------	---

W

Warnings	4
--------------------	---



71481806

www.addresses.endress.com
