

CHINO

LE5100

Hybrid Recorder

LE5200

Operation Type Intelligent Recorder

【I. Instruction Manual】

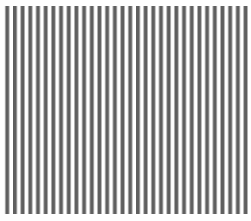

INSTRUCTIONS

CHINO

◆ Introduction / Request, Warranty Period, and Notices

Thank you for your purchase of LE5 series hybrid recorder having a 250mm recording width. Please read this instruction manual without fail for correctly and safely operating this unit and also preventing troubles in advance.

Separate instruction manual

This manual covers the operation of standard specifications and connection methods of a part of options. For operating each option, please read their instruction manuals together with this manual.

Request

1. To instrumentation, installation, and sales contractors

Be sure to pass this instruction manual to the user who uses this unit.

2. To the user

This instruction manual is also necessary for maintenance. Keep this manual carefully until the unit is discarded.

Notice

1. No part of this manual can be copied or reproduced in any form.
2. Alteration of the description contents in this manual is reserved without notice.
3. For the contents of this manual, we make assurance doubly sure. However, if a doubtful point, an error, and/or a description failure should have found, please inform your nearest branch or sales office.
4. You are requested to understand that we are not responsible for any operation results.



Warning

Perchlorate Material

This instrument uses battery with Perchlorate Material.

Special handling may apply, see

<http://www.dtsc.ca.gov/hazardouswaste/perchlorate>



Cautions for safe use

Observe the following cautions for using this unit safely.

1. Mounting place and terminal cover

① Panel mount type

This unit is designed to be mounted on an indoor instrumentation panel. For using this unit, mount it on the panel without fail. Take an electric shock preventive measure so that the user cannot directly touch any power supply or input/output terminals.

② Portable type

Mount an electric shock preventive cover to the terminal block.

2. Termination of wire connections

For terminating wires to the terminals, use insulation sleeve crimp style terminals. For power terminals and protective grounding terminal, use O-type insulation sleeves.

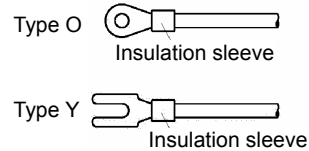

3. Mounting of a breaker to the feed power supply

Mount a switch conforming to the rated power supply of this unit and an over-current protective device to the power supply of this unit at an easy-to-access position within 3m.

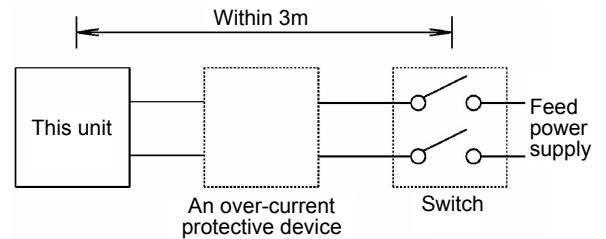

4. A safety measure to the output

Take a safety measure on the final product side as occasion demands when a control output or an alarm output is provided, otherwise an output failure of this unit may occur due to wrong operation, troubles, an abnormal sensor, or other failures.

5. Symbol marks employed in this unit

This symbol mark indicates a position where an electric shock accident may occur. Particularly be careful not to receive any electric shock during connections, check, and maintenance work.

This symbol shows a protective grounding terminal. Connect the instrument being indicated by this mark to the protective ground of the power supply equipment before starting its operation.

Warnings

Power voltage and protective grounding check	Check if connections are correct, the power voltage conforms to the specified voltage, and also the protective grounding is done without fail before feeding the power supply.
Don't put your hand into the case	Don't put your hand into the internal unit (rack) or case, except for the positions where are necessary for operating the unit, otherwise you may receive an electric shock or you may be injured.
Stop feeding the power supply if an abnormal symptom occurs	If abnormal odor, abnormal noises, smoke, or other abnormal symptoms occur or if the unit is too hot to touch it by hand, these symptoms show a dangerous condition. Turn off the feed power supply at once, and contact your nearest branch or sales office or the sales agent from which you have bought your unit.
Repair and modifications	If repair or modifications are necessary, please contact your nearest branch or sales office or the sales agent from which you have bought your unit. <Caution> Don't repair the unit by replacing its parts or modify it by any person other than a service engineer approved by our company.
Use according to the instruction manual	For using this unit correctly and safely, use it according to this instruction manual. You are requested to understand that we are not responsible for any injuries, damage, loss of profits or any other claims that were caused by wrong uses.

CONTENTS

LE5100 Hybrid Recorder

LE5200 Operation Type Intelligent Recorder

1. Introduction	
1-1 LE5100/LE5200	1-1
1-2 Profile	1-1
1-3 Input types	1-1
1-4 Check and confirmation	1-1
1-4-1 Appearance check	1-1
1-4-2 Attachments check	1-1
1-4-3 Type code No. check	1-2
1-5 Major functions	1-3—4
2. Names and functions of components	
2-1 Front section	2-1
2-2 Front section of internal unit	2-1
2-3 Display (status)	2-1—2
2-4 Keyboard	2-3
3. Mounting method	
3-1 Selection of mounting place	3-1
3-1-1 Ambient temperature and humidity	3-1
3-1-2 Factory environment	3-1
3-1-3 Mounting angle	3-1
3-2 Panel mounting method	3-1
3-2-1 External dimensions	3-1
3-2-2 Panel cutout	3-1
3-2-3 Mounting method	3-1
4. Connections	
4-1 Cautions on connections	4-1
4-2 Terminal boards (rear panel)	4-1
4-3 Connections of each terminal board	4-2
4-3-1 Measuring input terminal board	4-2
4-3-2 Power terminals	4-2
4-3-3 Communication I/F terminals, contact output terminals, and external drive terminals	4-3—4
4-3-4 Alarm output terminals	4-4
5. Installation of auxiliary products	
5-1 Mounting method of chart	5-1
5-2 Ribbon cassette mounting method	5-2
6. Operation	
6-1 Turning on the power supply	6-1
6-2 Display mode selection	6-1
6-3 Recording operation	6-2
7. Initial setting at the delivery time from the factory	
7-1 Setting items at the delivery time from the factory	7-1
7-2 Mode change by soft switch	7-2

8. Setting and changes by key operation

8-1 Basic rules	8-1
1. Setting items and setting parameters	8-1
2. Calling of setting items	8-1
3. Calling of setting parameters	8-1
4. Acceptance and acceptance failure of keys	8-1
5. No. of parameters by setting items	8-1
6. Confirmation of setting parameters	8-1-3
7. Setting change	8-4
8. Switching of keys	8-4
9. Setting change mark	8-4
10. Setting decision function	8-4
11. Basic entry of setting parameters	8-5-6
8-2 Display setting	8-7
8-3 Channel parameter setting	8-8-9
1. Operation recording	8-10
2. Data communication input	8-11
8-4 Dot setting	8-12
8-5 Chart recording setting	8-13-14
8-6 Alarm setting	8-15-17
8-7 Differential recording setting	8-18-20
8-8 Message printing setting	8-21
8-9 List printing setting	8-22
8-10 Data interval recording setting	8-23
8-11 Logging recording setting	8-24
8-12 Data print recording setting	8-25
8-13 Display setting	8-26
8-14 Engineering port setting	8-27
8-15 Date and time setting	8-28
8-16 System setting	8-29
8-17 PC card (memory card) setting	8-30
8-17-1 Summary	8-30
8-17-2 Mounting	8-30
8-17-3 Operation	8-30
8-17-4 Handling of PC card	8-31
8-17-5 PC card setting	8-31
8-17-6 Setting of measuring data saving by PC card	8-32
8-17-7 Setting of set value saving by PC card	8-33
8-17-8 Setting of reading out a set value by PC card	8-34
8-17-9 PC card format	8-35
8-17-10 PC card removing	8-36

9. Adjustment function

9-1 Zero and span adjustment of analog recording	9-1
9-2 Zero and span adjustment of measured values	9-2
9-3 Shift adjustment of measured values	9-3
9-4 Calibration	9-4

10. Troubleshooting

Troubleshooting table	10-1
-----------------------	------

11. Maintenance and check

Maintenance and check	11-1
11-1 Recommendable parts exchange cycles	11-2
11-2 Disposal	11-2

12. General specifications

General specifications	12-1-5
------------------------	--------

13. Option specifications

Option specifications	13-1
13-1. External drive	13-2-4
13-2. Alarm output	13-5
13-3. Recording format	13-6
13-3-1. Automatic range selection recording	13-7
13-3-2. Partial compression and expansion recording	13-8
13-3-3. Parallel scale recording	13-9
13-4. Rate-of-change alarm/Differential alarm	13-10
13-4-1. Rate-of-change alarm	13-10
13-4-2. Differential alarm	13-11
13-5. Operation	13-12-16

1. Introduction

1-1 LE5100/LE5200

This hybrid recorder having a 250mm chart measures and records temperature (thermocouple, resistance thermometer bulb) inputs, DC voltage (mV, V) inputs, and other various industrial variables.

- 1) **High speed input entry and high-speed recording**
This unit scans test data, inspection data, experimental data, and multi-point data in quick change processes at a ratio of 36 points/100ms, and records them at a rate of approx. 1 line/3s.
- 2) **High precision**
The accuracy rating of measuring ranges is $\pm 0.05\%$, and the maximum resolution is $1\mu\text{V}$ or 0.1°C .
- 3) **Easy operation**
Various setting can be done in the conversational mode without any complicated operation unlike in general high-grade units. Setting can also be done by a personal computer or a PC card.
- 4) **Noise resistance**
This unit is characterized with a high induction noise resistance of 130dB in common mode and 50dB in series mode. For impulse noises, an individual filter is provided every channel.

1-2 Profile

This unit comprises a 12-point input type, a 24-point input type, and a 36-point input type. This unit can be operated and set without opening the door in all types.

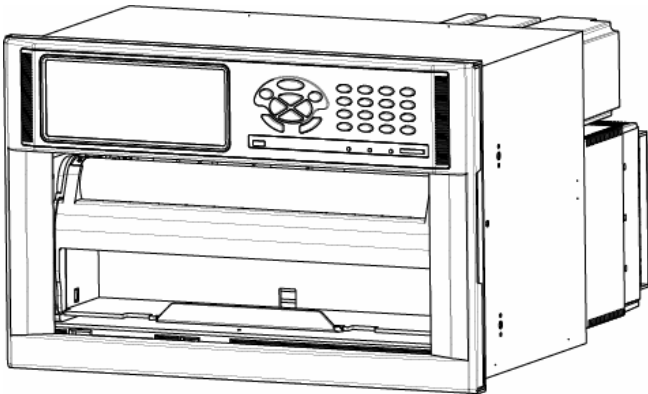

1-3 Input types

This unit is characterized with a full multi range of thermocouple (TC), resistance thermometer bulb, and DC voltage (mV, V) inputs.

1-4 Check and confirmation

Check the unit for the following items before operating it.

1-4-1 Appearance check

After unpacking, check the following items to see if the unit is normal in appearance.

- ① Check if the front glass is free of breakage and flaws.
- ② Check if the door can be opened and closed smooth.
- ③ Check if the entire case is free of flaws and dirt.

1-4-2 Attachments check

The following attachments are contained.

Attachments table

Article names	Quantity	Remarks
① Ribbon cassette	1 pc.	For recording
② Chart ※	2 boxes	Each contains 2 pads
③ Lubricating oil (10cc)	1 bottle	For maintenance
④ Terminal screw (spare)	5 pcs.	M3.5 x 8
⑤ Mounting bracket and mounting screw	4 pcs. each	For mounting the panel
⑥ Wrench	1 pc.	For mounting the panel
⑦ Instruction manual	1 pad	

※ Standard chart is chart No. LE-01001A. Its ordering unit is one large box (containing 15 pads).

1-4-3 Type code No. check

The operation may change according to the types. Confirm the type of your unit.

■ Type table

LE5□□□-□□□

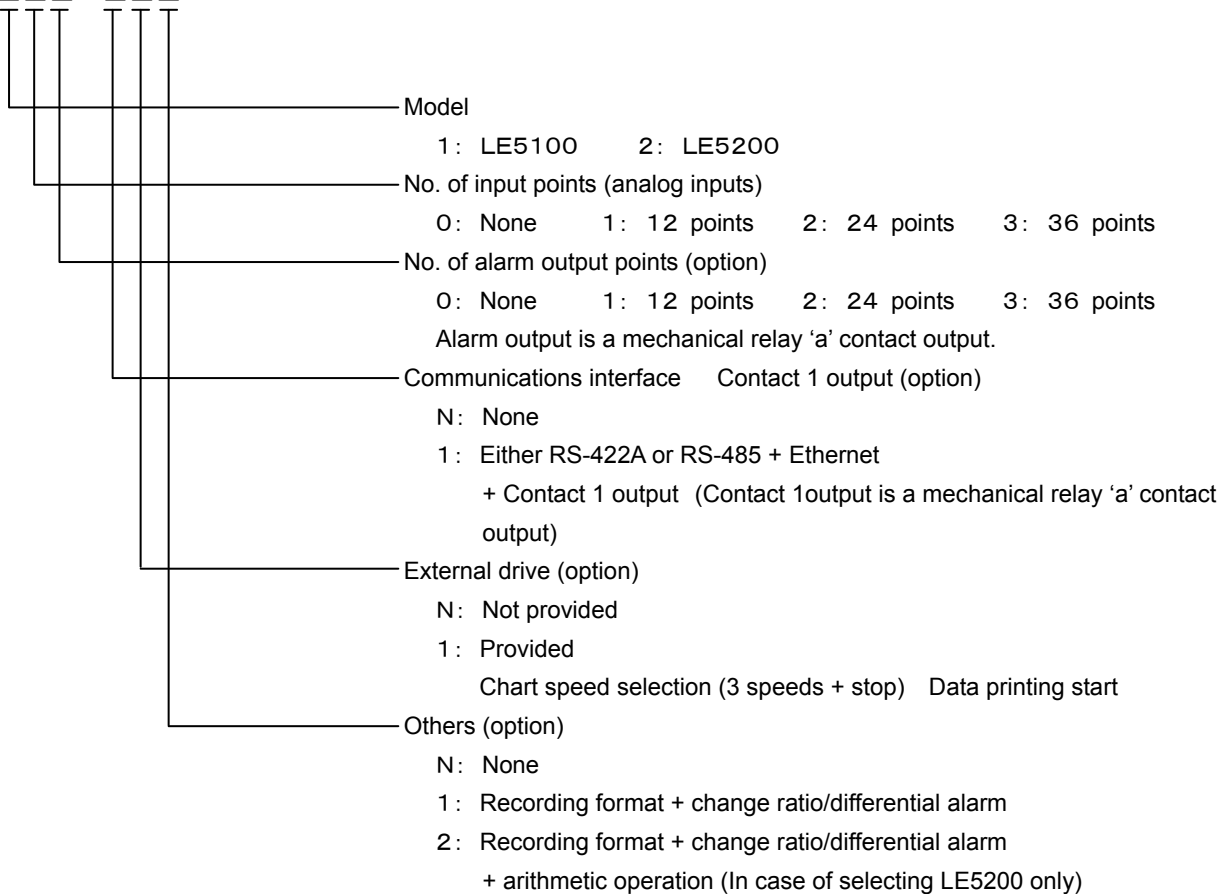

Type: LE52□□-□□2

When select LE5200 in model, others (option) is fixed [2].

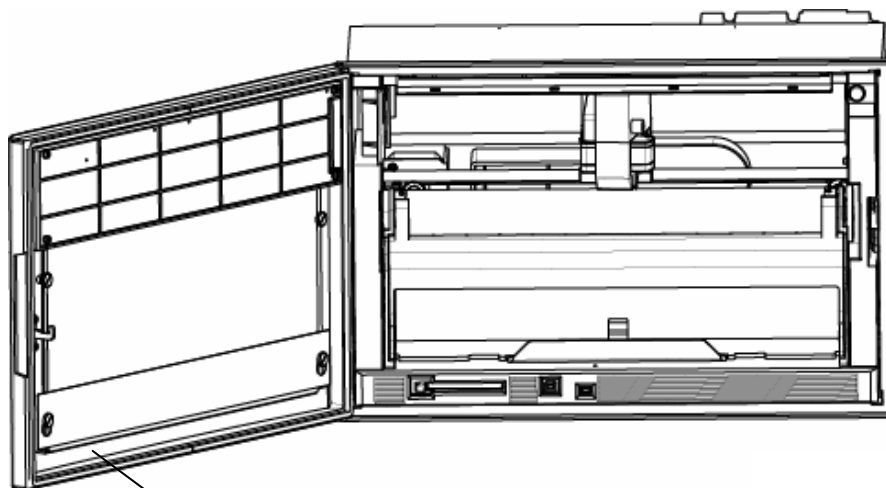

LE5133-112
 LE061A001
 MADE IN JAPAN

1-5 Major functions

This unit provides various functions. For details of setting and operation, refer to each item No.

Functions	Items	Contents	Page No.
1. Digital display	① Measuring data display	Measuring data in each channel are displayed. Channel No. (3 digits) + tag (8 digits) + range (3 digits) + measured value (7 digits) An 8-digit tag can be set and displayed. In case of collective display of 36 points, 5-digit display is done by justifying left digits. A unit can also be displayed instead of the tag, and its display mode is the same as in the tag. (Simultaneous display of both tag and unit cannot be done.)	Page 2-2
	② Display mode	1) Each measuring data is fixed or sequentially displayed every channel. 2) 12-point measuring data are displayed collectively. 3) 24-point measuring data are displayed collectively. 4) 36-point measuring data are displayed collectively. ※ The update cycle of 1 channel display is 2 seconds as a factory delivery value (default). 5) In case of 24 or 36 input points, each measuring data is fixed or sequentially displayed every 12 points. ※ The update cycle of 12 · 24 · 36 points display is 3 seconds as a factory delivery value (default). 6) The type code, serial No., and version No. of software of this unit are indicated. The chart speed, date (year, month, day), and time are indicated at all times in all display modes 1) - 6).	Page 2-2
	③ Status display	1) KEY LOCK : Indicated when operation keys are locked. 2) CHART END : Indicated when the chart comes to an end. 3) FAIL : Indicated when the unit is in trouble.	Page 2-1 Page 2-2
	④ Alarm status display	1) Measuring data in an alarm channel are displayed red. ※ Red ALM LED flickers.	Page 2-1 Page 2-2
	⑤ Setting data display	Setting conditions can be confirmed by displaying various parameters by means of key operation.	Page 8-1
2. Analog recording	① No. of recording points	Setting inputs and arithmetic results can be recorded by max. 36 channels, respectively.	Page 8-10
	② Recording color designation	A recording color can be designated optionally every channel (out of 10 colors).	Page 8-10
	③ Tag number printing	Tag numbers (channel numbers) are printed beside the trend recording at a fixed interval.	—
	④ Scale and unit printing	A scale and a unit are printed at both ends of the chart every fixed time.	—
	⑤ Alarm mark printing	When an alarm occurred or when the alarm was reset, _ (red) or _ (green) mark is printed beside the trend recording, and also, the time, channel number, and kinds of levels are printed at the right end of the chart.	—
	⑥ Skip function	A designated channel can be skipped.	Page 8-10
	⑦ Analog recording format (option)	Parallel recording, partially compressed/enlarged recording, and automatic range selection recording can be selected.	—
3. Digital recording	① Data interval recording	Digital recording is done at an optional interval (time and minute) from a designated start time by overlapping it with analog recording.	Page 8-21
	② Data printing	Digital recording is done at the requested time while interrupting analog recording.	Page 6-2
	③ Logging recording	Digital recording is done at an optional interval (time and minute) from a designated start time.	Page 8-22
	④ Digital recording format	Measuring data, tag number, unit, chart speed, date (year, month, day), and time are printed. Three kinds of recording formats can be designated optionally.	Page 8-21 Page 8-23
	⑤ Skip function	A designated channel can be skipped.	Page 8-8
4. Arithmetic results recording	① Differential recording	1) A difference of measuring data between designated channels is recorded in an optional designated channel. 2) A difference between measuring data of a designated channel and the reference value (optional setting) can be recorded in an optional designated channel.	Page 8-16
	② Arithmetic results recording (option)	1) The maximum, minimum, average, and total values of measuring data between designated channels are recorded in an optionally designated channel. 2) A time series change (maximum, minimum, average, and integration) at an optional interval of measuring data between designated channels can be recorded in an optional channel from a designated start time. 3) Perform function mathematics which can be shown numerical formula, and record optional channel.	—

Functions	Items	Contents	Page No.
5. Digital printing	① Year, month, day, and time printing	Year, month, day, and time (time line) are printed at a designated interval.	—
	② List printing	1) A list of all parameters is printed at a requested time. 2) A list of designated parameters is printed at a requested time.	Page 8-20
	③ Message printing	1) A message of max. 75 characters can be printed by designating a channel. 2) A message of max. 80 characters can be printed without designating any channel. (A message is prepared by alphanumeric characters and symbols being displayed on the setting keyboard.)	Page 8-19
	④ Title printing (option)	A comment of max 80 characters x 5 lines can be printed. (A title sentence is English characters (capitals and small letters), numeric characters, symbols, and others provided on the PC keyboard.)	—
6. Parameter entry	① Operation keys	1) Running operation: Data display selection, recording ON/OFF, data printing, chart feed. 2) Setting: Time, chart speed, range, and all other functions can be set and confirmed.	Page 2-3
	② PC card	Setting contents can be entered and collectively set to this unit by easy key operation.	—
	③ PC setting	Setting can be done by exclusive engineering software (option) with a PC employed as the setting tool. Setting contents can be confirmed.	—
7. Self diagnostic function	① Self check function	Instrument conditions are checked by executing self-diagnosis at all times.	—
	② Setting decision function	Setting contents are checked to inform of abnormal conditions, if any. 1) Defective contents check <ul style="list-style-type: none"> • Format check • Restriction check 2) A window is opened on the setting screen to display a message of defective contents.	Page 8-4
	③ Hardware check function	Hardware conditions of the instrument are checked.	—
8. Communication function USB: Standard RS-422A/485 Ethernet (option)	① Setting	All parameters can be set and confirmed.	—
	② Operation	All operation can be done.	—
	③ Data output	Measuring data are output according to the request from the host CPU.	—
	④ Kinds	1) RS-422A 2) RS-485 3) USB 4) Ethernet	—
9. Auxiliary functions	① Input value correction function	Input values can be corrected every channel by key operation.	Page 9-2
	② Recording correction function	Zero point and span point can be corrected by key operation.	Page 9-1
	③ Parameter protection function	1) Setting parameters are protected by EEP-ROM when turning off the power supply. 2) Clock is backed up for longer than 5 years by a lithium battery.	—
	④ Burnout function	Thermocouple or resistance thermometer bulb overshoots to its higher-limit, if broken. (ON-OFF selectable)	Page 8-8

2. Names and functions of components

2-1 Front section

Operation and setting can be done without opening the door so that the front section is fully dust-proof.

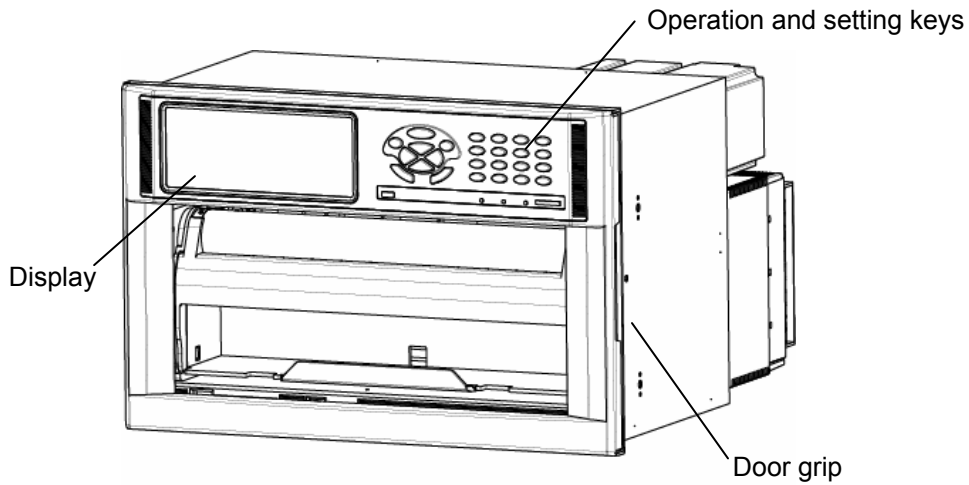

2-2 Front section of internal unit

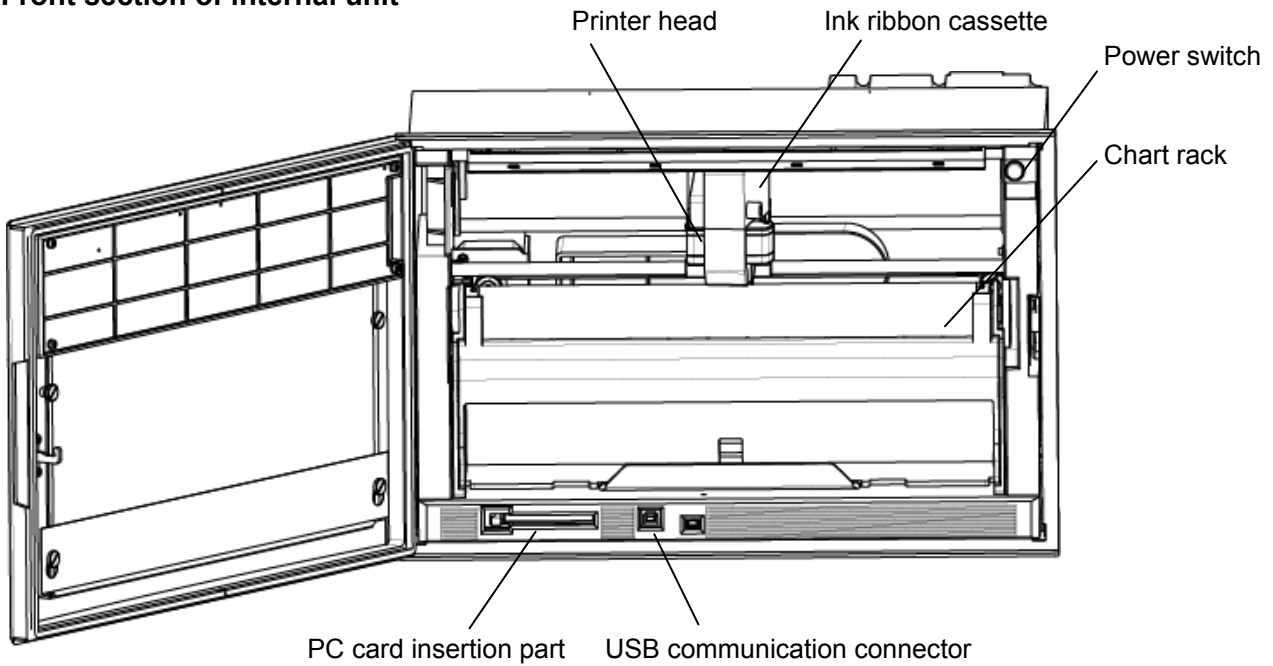

2-3 Display (status)



- **ALM**
Red LED flickers in the occurrence of an alarm.
- **PC. CARD**
Green LED remains lit when PC card is being inserted.
- **REC. ON**
Green LED lights when recording is turned on. Recording is turned on or off by REC key.
- **CHINO**
CHINO brand lights when power is turned on.

• **Indications of the display section**

Measuring data display

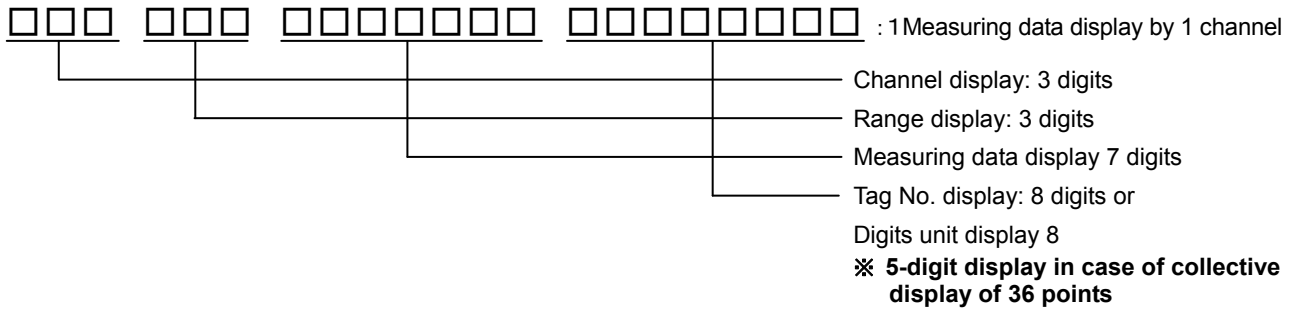

The following six screens are selectable according to the uses during run.
(Described update cycles show the initial setting values at the delivery time from the factory.)

1. RECORD ON 20mm/h 2005/06/03 15:25:30

CH.	TAG	DATA
001	FT00257	1245.8

INPUT	UNIT
K	°C

Enter Ch.set Menu Menu Func1 AUTO/CONST Func2 ALARM conf. Const

Measuring data are fixed or sequentially displayed every channel. These data are updated to the next channel by ▲ or ▼ key. The above keys can be used for sequentially display. In the sequential display mode, measuring data are updated to the next channel at 2-second cycle. Also, measured values display is updated every second.

4. RECORD ON 20mm/h 2005/06/03 15:25:30

CH.	INPUT	DATA	TAG	CH.	INPUT	DATA	TAG	CH.	INPUT	DATA	TAG
001	K	1215.3	FT001	013	K	1215.3	FT013	025	K	1215.3	FT025
002	JPt	205.5	FT002	014	JPt	205.5	FT014	026	JPt	205.5	FT026
003	JPt	115.3	FT003	015	JPt	115.3	FT015	027	JPt	115.3	FT027
004	JPt	-50.8	FT004	016	JPt	-50.8	FT016	028	JPt	-50.8	FT028
005	R	1605.9	FT005	017	R	1605.9	FT017	029	R	1605.9	FT029
006	T	220.5	FT006	018	T	220.5	FT018	030	T	220.5	FT030
007	K	809.3	FT007	019	K	809.3	FT019	031	K	809.3	FT031
008	K	1005.3	FT008	020	K	1005.3	FT020	032	K	1005.3	FT032
009	JPt	125.3	FT009	021	JPt	125.3	FT021	033	JPt	125.3	FT033
010	R	1465.7	FT010	022	R	1465.7	FT022	034	R	1465.7	FT034
011	R	1335.4	FT011	023	R	1335.4	FT023	035	R	1335.4	FT035
012	JPt	-60.3	FT012	024	JPt	-60.3	FT024	036	JPt	-60.3	FT036

Enter Ch.set Menu Menu Func1 AUTO/CONST Func2 ALARM conf. Const

Measuring data at 36 points are displayed collectively. (In case of the instruments where No. of input points is 36 points) Skipped channels are kept blank. Each display area is not changed. The same processing also applies to the channels where no range is set. Measured values display is updated every second.

2. RECORD ON 20mm/h 2005/06/03 15:25:30

CH.	INPUT	DATA	TAG	CH.	INPUT	DATA	TAG
001	R	200.5	FTG001	007	R	1125.3	FTG007
002	K	1265.8	FTG002	008	K	1265.8	FTG008
003	T	359.8	FTG003	009	T	200.3	FTG009
004	JPt	-125.3	FTG004	010	R	1625.4	FTG010
005	mV	9.235	FTG005	011	mV	8.604	FTG011
006	R	1265.8	FTG006	012	JPt	150.3	FTG012

Enter Ch.set Menu Menu Func1 AUTO/CONST Func2 ALARM conf. CONST

Measuring data at 12 points are displayed collectively. (In case of the instruments where No. of input points is 12 points.) Skipped channels are kept blank. Each display area is not changed. The same processing also applies to the channels where no range is set. Measured values display is updated every second.

5. RECORD ON 20mm/h 2005/06/03 15:25:30

CH.	INPUT	DATA	TAG	CH.	INPUT	DATA	TAG
001	R	200.5	FTG001	007	R	1125.3	FTG007
002	K	1265.8	FTG002	008	K	1265.8	FTG008
003	T	359.8	FTG003	009	T	200.3	FTG009
004	JPt	-125.3	FTG004	010	R	1625.4	FTG010
005	mV	9.235	FTG005	011	mV	8.604	FTG011
006	R	1265.8	FTG006	012	JPt	150.3	FTG012

Enter Ch.set Menu Menu Func1 AUTO/CONST Func2 ALARM conf. CONST

Measuring data are fixed or sequentially displayed every 12 points. (In case of the units where No. of input points is 24 points or 36 points.) These data are updated to the next 12 points by ▲ or ▼ key. The above keys can be used for sequentially display. In the sequential display mode, measuring data are updated to the next 12 points at 3-second cycle. Also, measured values display is updated every second.

3. RECORD ON 20mm/h 2005/06/03 15:25:30

CH.	INPUT	DATA	TAG	CH.	INPUT	DATA	TAG
001	K	1215.3	FT001	013	K	1215.3	FT013
002	JPt	205.5	FT002	014	JPt	205.5	FT014
003	JPt	115.3	FT003	015	JPt	115.3	FT015
004	JPt	-50.8	FT004	016	JPt	-50.8	FT016
005	R	1605.9	FT005	017	R	1605.9	FT017
006	T	220.5	FT006	018	T	220.5	FT018
007	K	809.3	FT007	019	K	809.3	FT019
008	K	1005.3	FT008	020	K	1005.3	FT020
009	JPt	125.3	FT009	021	JPt	125.3	FT021
010	R	1465.7	FT010	022	R	1465.7	FT022
011	R	1335.4	FT011	023	R	1335.4	FT023
012	JPt	-60.3	FT012	024	JPt	-60.3	FT024

Enter Ch.set Menu Menu Func1 AUTO/CONST Func2 ALARM conf. Const

Measuring data at 24 points are displayed collectively. (In case of the instruments where No. of input points is 24 points.) Skipped channels are kept blank. Each display area is not changed. The same processing also applies to the channels where no range is set. Measured values display is updated every second.

6. RECORD ON 20mm/h 2005/06/03 15:25:30

TYPE AND SERIAL : LE51301NN LE062B007
MAC Address : 00 00 00 00 00 00
IP Address : 192.168.254.254

MAIN CPU VER 1.04
CHART CPU VER 1.0110
KEY CPU VER 0.00

Enter Ch.set Menu Menu Func1 AUTO/CONST Func2 ALARM conf. Const







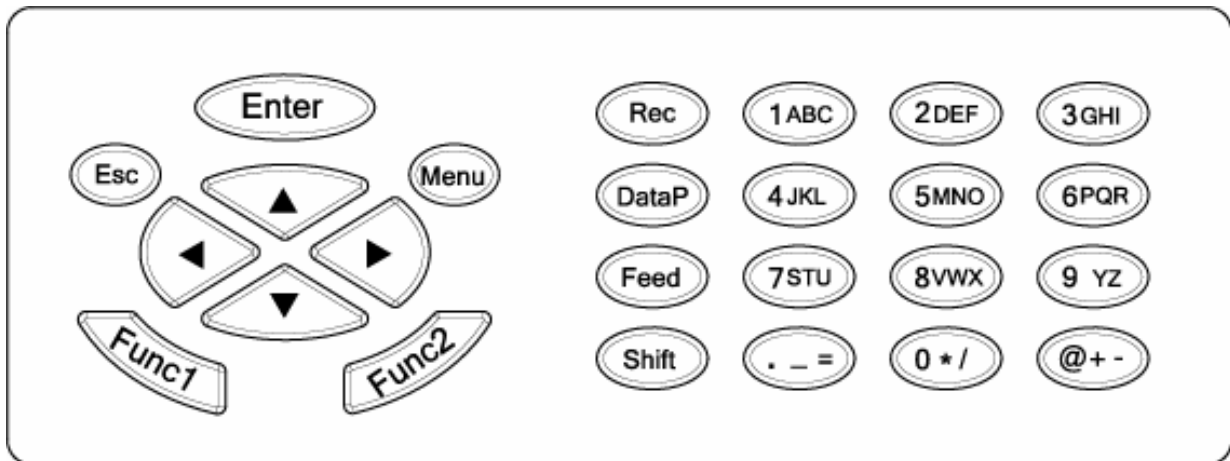



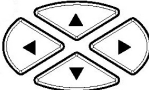

Type code, serial No., software version number, IP address, and MAC address of this unit are displayed.

In all screens, various status, chart speed, date (year, month, day), and time are always displayed at the upper part of the display, while various setting procedures are always displayed at the lower part of the display.

2-4 Keyboard



• Names and functions of keys

Names of keys		Functions
	Enter key	Enters various setting.
	Escape key	Returns the screen to the last one each time this key is pressed once.
	Menu key	Displays various setting items.
	Up-Down, Left-Right keys	These keys are used to shift the cursor upward, downward, leftward, or rightward. They are used for selecting setting items and numeric values.
	Function key 1	Switches and sets various functions. Displays the function at the lower part of display.
	Function key 2	Switches and sets various functions. Displays the function at the lower part of display.
	Record key	Turns on or off recording. This key is used together with Enter key.
	Data print key	Prints data momentarily when pressing this key. This key is used together with Enter key.
	Feed key	Feeds the chart at a speed of 750mm/min when this key is being pressed.
	Shift key	Selects numeric keys and alphabetic or other symbolic keys.
	Numeric key	Used for inputting a numeric value.
	Alphabetic key	Used for inputting alphabetic characters (together with Shift key).
	Symbol key	Used for inputting symbols (together with Shift key).

When alphabetic keys are used for setting the tag, unit, etc., press [Shift] key according to the guidance in the display unit. The contents being input by pressing keys are switched by pressing [Shift] key.

Example) In case of inputting [C]

Switch the input mode of the key by pressing Shift key.

[C] can be input by pressing [1ABC] key 4 times.

3. Mounting method

This unit can be used on a desk or the like, but it is constructed to be used by mounting it on a panel (instrument panel).

3-1 Selection of mounting place

3-1-1 Ambient temperature and humidity

Temperature range : 0 to 40°C
 Humidity range : 20 to 80%RH
 A stable place within the above ranges

3-1-3 Mounting angle

Front tilting angle : 0°
 Rear tilting angle : 0 to 15°
 Lateral angle : 0°

A mounting angle other than specified above may affect the recording operation.

3-1-2 Factory environment

Select a place being separated from electric field and magnetic field generation sources and also free of mechanical vibrations and shocks.

- Overvoltage category : II
- Pollution degree : 2
- Altitude : Lower than 2000m
- Working place : Indoors

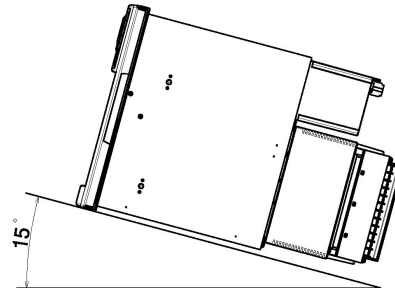

3-2 Panel mounting method

3-2-1 External dimensions

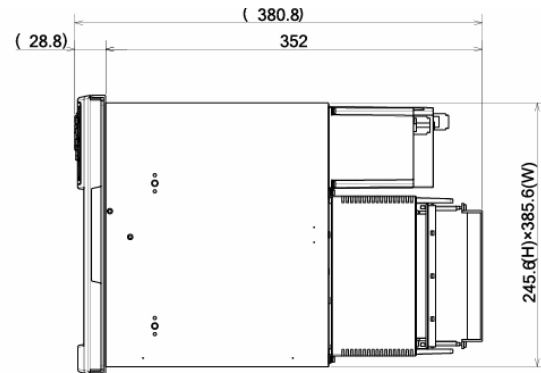
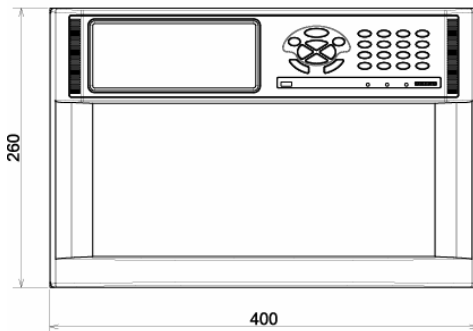

3-2-2 Panel cutout

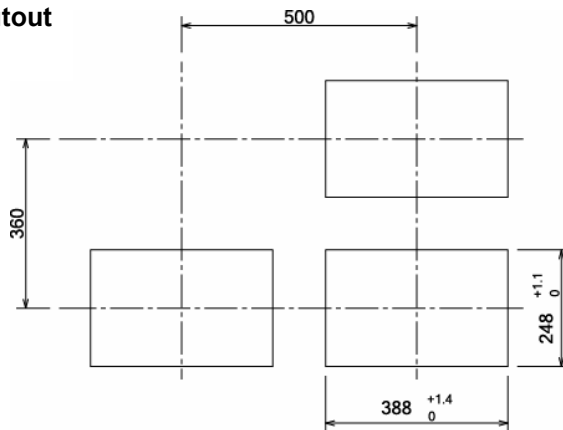

Panel cutout and Minimum mounting dimensions

3-2-3 Mounting method

Insert this unit into the panel cutout of the instrument panel. Screw in four attached mounting screws into the screw holes at 2 upper and lower places (4 places in total) on the right and left side panels of the unit. Insert the mounted hexagonal screw heads into the round holes of the mounting brackets, press the unit toward the instrument panel securely from the front while sliding it as illustrated below, and fasten the screws by the attached spanner or plus screwdriver under the above condition. Be careful since the mounting brackets differ from each other on the right and left sides (Mount the unit by 2 persons)

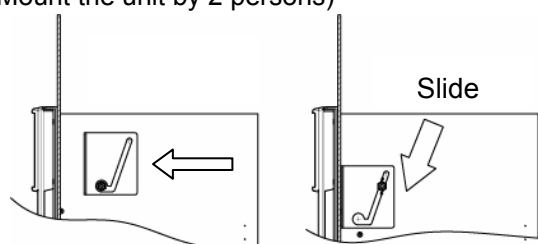

4. Connections

4-1 ⚠ Cautions on connections

1. Feed source power supply

- For feeding power to the unit, use a single-phase power source having the stable voltage without any distorted waveform for the purpose of preventing wrong operation.

2. Separate the power supply from strong electric circuits

- Avoid connecting the input /output lines in the vicinity of and/or in parallel with a drive power line or other strong electric circuits. Separate the unit from them more than 50cm if the unit is in the vicinity of and/or in parallel with them.

3. Separate the thermocouple input from a heat source

- Separate the terminals from a heat source (a heating body) for reducing a reference junction compensation error. Avoid the solar radiation or the like.

4. Separate the unit from a noise source

- Separate the unit from a noise source as far as possible, otherwise an unexpected trouble may occur. Take a noise-preventive measure, if the unit cannot be separated from a noise source.

Major generation sources	<ul style="list-style-type: none"> ● An electromagnetic switch or the like ● A power line having waveform distortion ● An inverter ● A thyristor regulator
Countermeasure	Insert a noise filter between the power supply and input/output terminals. A CR filter is used in many cases.

5. Use crimp style terminals

- ① Attach crimp style terminals to the connection cord ends for preventing terminals from being loosened or disconnected or a short circuit failure across terminals.
- ② Use crimp style terminals each having an insulation sleeve for preventing an electric shock accident.

6. Unused terminals

- Don't use any unused terminal as a relaying terminal, otherwise electric circuits may be damaged. For unused terminals, short plus and minus terminals for preventing the influences of external noises.

4-2 Terminal boards (rear panel)

The terminal boards are roughly divided into ① measuring input terminals, ② power terminals, ③ communication I/F terminals, contact output terminals, external drive terminals, and ④ alarm output terminals. Terminals ③ and ④ are not always mounted depending upon the unit because of their option specifications.

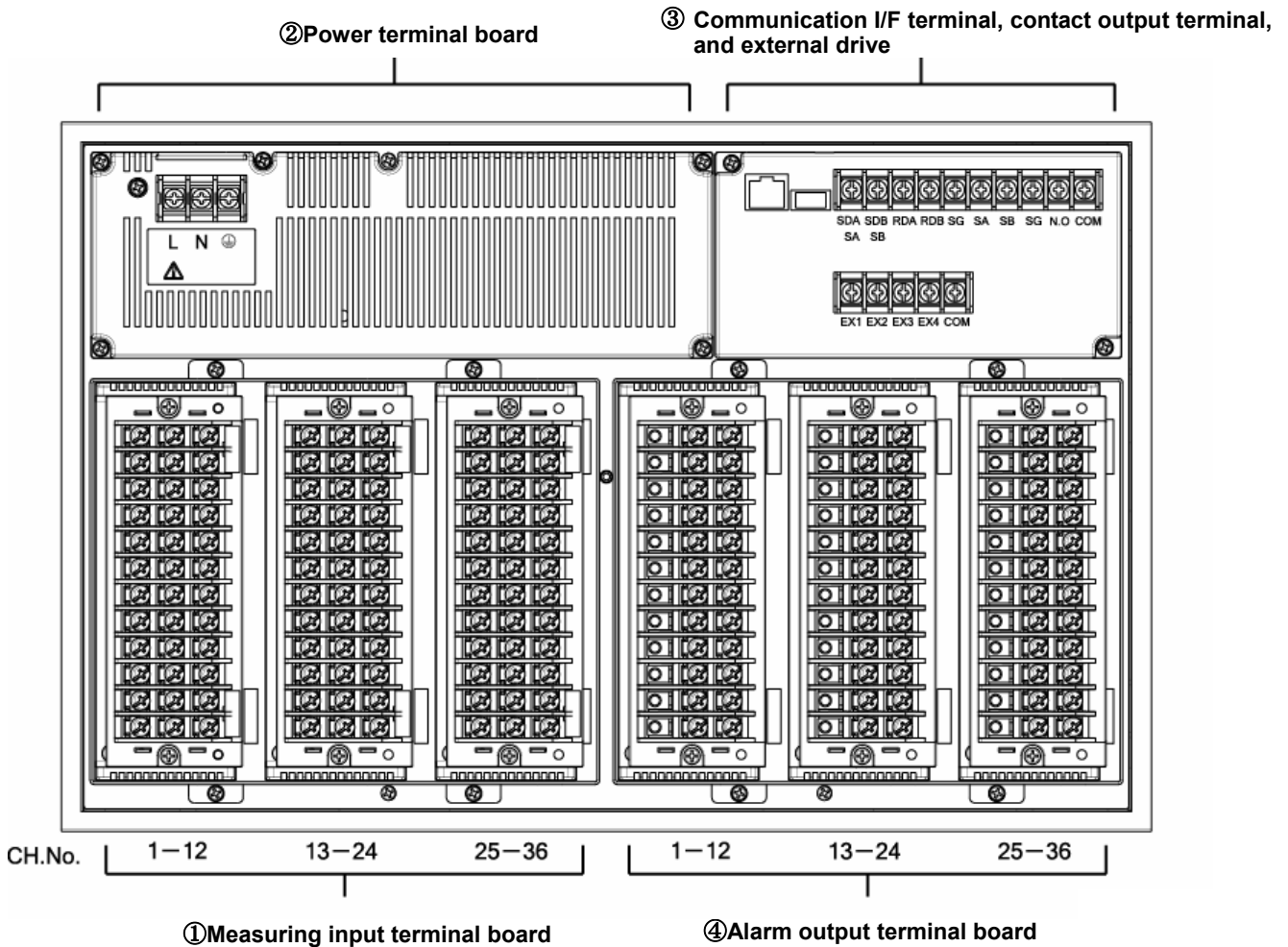

The above figure includes option terminals.

4-3 Connections of each terminal board

4-3-1 Measuring input terminal board

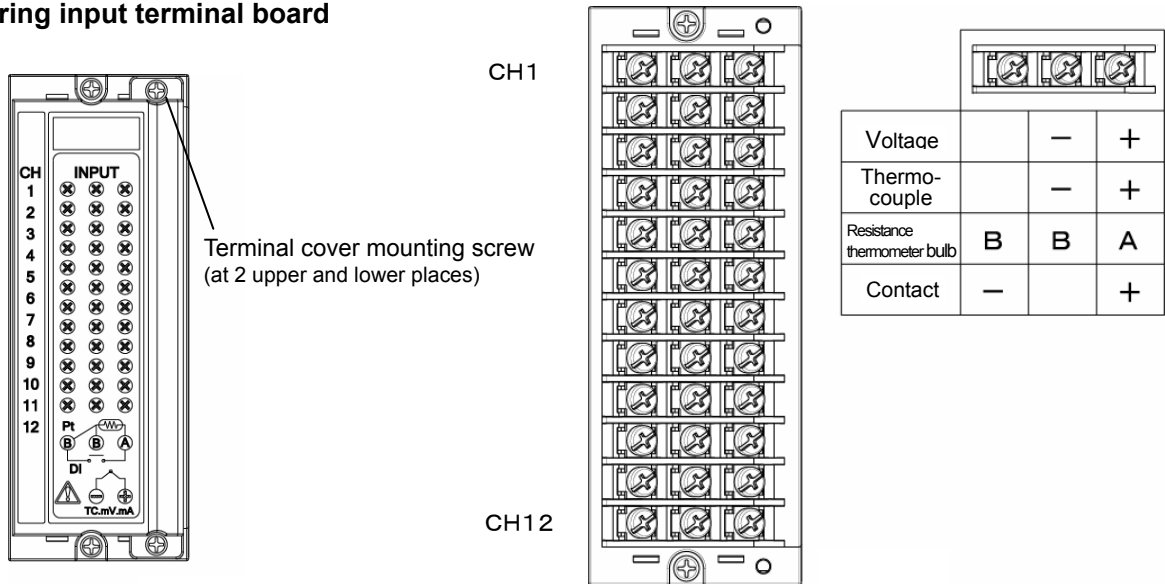

! Cautions

1. Connect a voltage lower than the allowable input voltage to the input terminals.
 - ① Voltage, thermocouple input ----- $\pm 10\text{VDC}$
 - ② Resistance thermometer bulb ----- $\pm 6\text{VDC}$
2. Turn off the feed power source before starting connections for preventing an electric shock accident.
3. Mount crimp style terminals each having an insulation sleeve as input terminals.
4. For a DC voltage (current) input, use a twisted wire for instrumentation as a noise preventive measure. Connect a current input receiving resistor to the channel to be measured before connecting the current input.
5. Connect the thermocouple input by using the thermocouple wire (or compensation lead wire) to the unit without fail. If a copper wire is connected halfway, a noticeable error occurs. Don't connect a part of thermocouple wires in parallel with other instruments (a controller or the like), otherwise a trouble may occur.
6. For connecting the resistance thermometer bulb input, use a 3-conductor cord having an equal resistance value of each conductor wire. Don't connect a resistance thermometer bulb in parallel with any other instrument (a controller or the like)
7. A high voltage may be applied to the measuring input terminals due to common mode noises. The allowable value of noises is lower than 30VAC or 60VDC. Make sure that noises are lower than specified. After connecting terminals, mount a terminal cover for preventing an electric shock accident and also protecting the input wires. In case of the thermocouple input, a reference junction compensation error is reduced by mounting the terminal cover.

4-3-2 Power terminals

Power cable:

600V vinyl insulated wire
Crimp style terminal having an insulation sleeve.

Note:

- Use the following standard cords ①-③.
- ① IEC 227-3
 - ② ANSI/UL817
 - ③ CSA C22. 2 No. 21/4

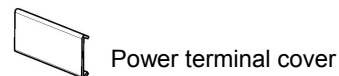
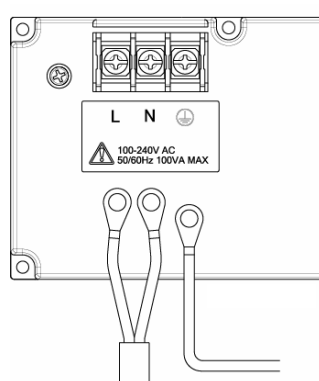

Grounding wire:

Connect to the protective conductor of the power supply equipment.

Crimp style terminal having an insulation sleeve
A copper cable each having a wire diameter of 2mm² at least Green/yellow

! Cautions

1. Turn off the feed power source without fail before connecting the power terminals and protective conductor terminals for the purpose of preventing an electric shock accident.
2. The power voltage of this unit is indicated at the power terminal block. If a voltage other than indicated should be applied, a trouble or an operation failure occurs. If power noises are introduced, take a preventive measure by connecting a noise cutting transformer to the ground or other preventive means.
3. A 100-240V AC voltage is applied to the power terminals after connections. Mount the power terminal cover without fail after connections for preventing an electric shock accident.

4-3-3 Communication I/F terminals, contact output terminals, and external drive terminals

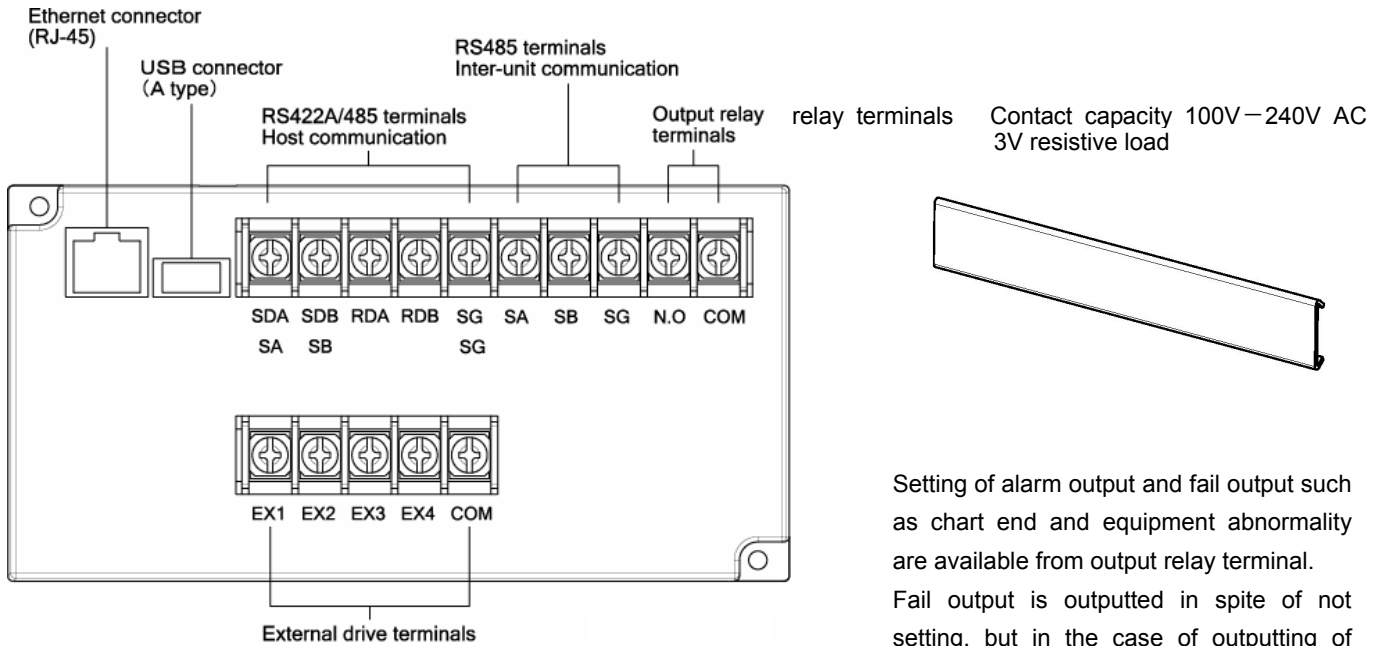

1. Ethernet connection (host communication)

[For connecting to PC at a ratio of 1 to 1]

For connecting the Ethernet IF to PC at a ratio of 1 to 1, use a cross type STP cable.

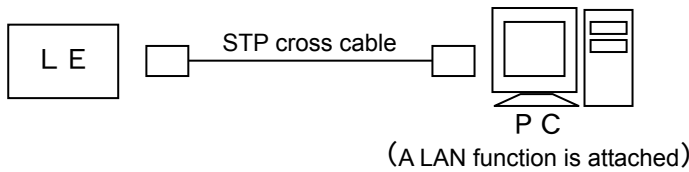

[For connecting to PC at a ratio of N to N]

For connecting to plural PC units or existing LAN, use a switching hub, and connect a straight type STP cable between the switching hub and the Ethernet unit.

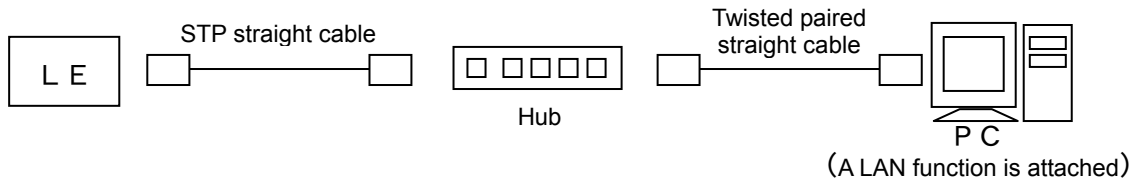

2. RS422A/RS485 terminal connections (host communication)

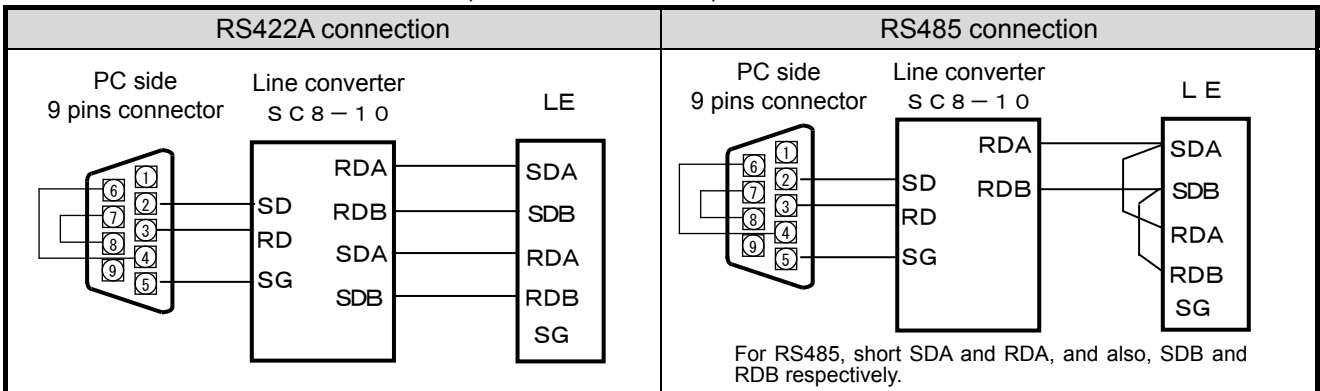

3. Output relay terminal connections

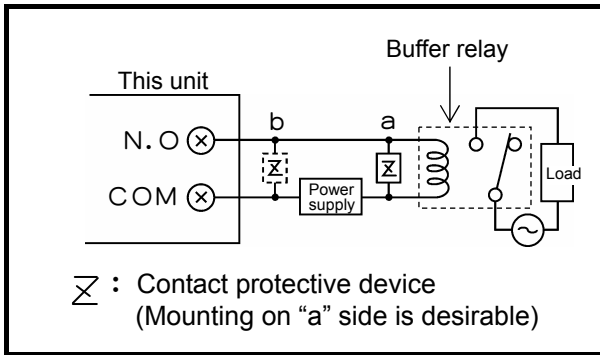

! Cautions

1. Connect a load of less than the designated contact capacity to the output relay terminals.
2. Turn off the feed power source and buffer relay power supply before starting connections for preventing an electric shock accident.
 - ① Connect output relay terminals to the load via a buffer relay.
 - ② For connection to the output terminals, use crimp style terminals each having an insulation sleeve.
3. The buffer relay power supply is applied to the output relay terminals after connections and an electric shock accident occurs if you should touch these terminals. Mount a terminal cover without fail after connections.

4. External drive connections and operation selection

The following operation can be executed by contact signals from the terminals.

- ① Selection of 3 chart speeds (speed numbers)
- ② Recording execution and stop
- ③ Data printing

! Cautions

Turn off the feed power source before starting connections of external drive terminals for preventing an electric shock accident.

External drive functions and inter-terminal conditions

External drive functions	Across COM – EX□ terminals				Remarks
	EX1	EX2	EX3	EX4	
Chart speed 1	OFF	OFF	OFF	OFF	Receiving and feed operation by setting keys are effective. For changing the selected chart speed number and chart speed, refer to the instruction manual, option volume.
Chart speed 2	ON	OFF	OFF	OFF	
Chart speed 3	OFF	ON	OFF	OFF	
Recording execution and stop	OFF	OFF	ON	OFF	Receiving and feed operation by setting keys are ineffective.
Data printing	OFF	OFF	OFF	ON	Keep ON time for longer than 1 second.

※) Data cannot be printed unless recording is being executed.

! Cautions

For the contacts being connected to the external drive terminals, use contacts of a switch, a relay, or the like which is driven by lower than 30V AC or 60V DC or use manual contacts.

4-3-4 Alarm output terminals

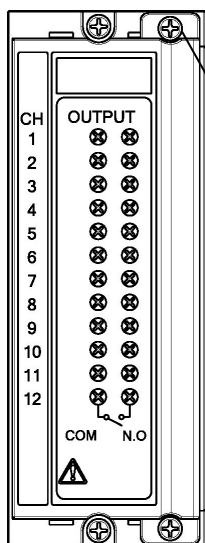

Terminal cover screw
(Remove two upper and lower screws respectively)

CH1

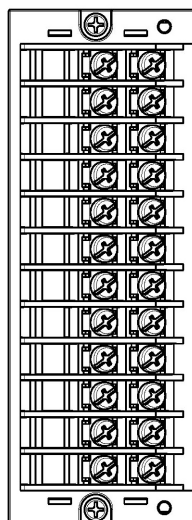

CH12

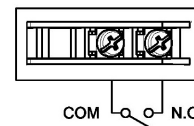

Power supply	Resistive load	Inductive load
100VAC	0.5A	0.2A
240VAC	0.2A	0.1A
30VDC	0.3A	0.1A

(Caution 1) The alarm output is a mechanical relay “a” contact output. For connections, refer to [3. Connections of output relay terminals].

5. Installation of auxiliary products

5-1 Mounting method of chart

- ① After opening the door, take out the chart rack by pulling it this side.

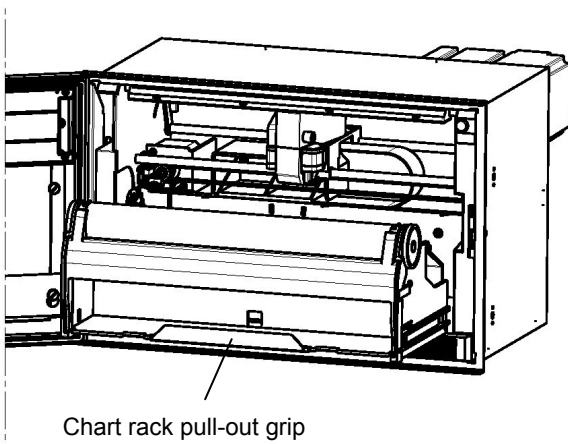

- ④ The chart is provided with circular holes at the left end and elliptical holes at the right end. Put the chart into the chart loading section horizontally under the condition.
※ Shuffle the chart sufficiently before setting the chart for preventing a double feed.

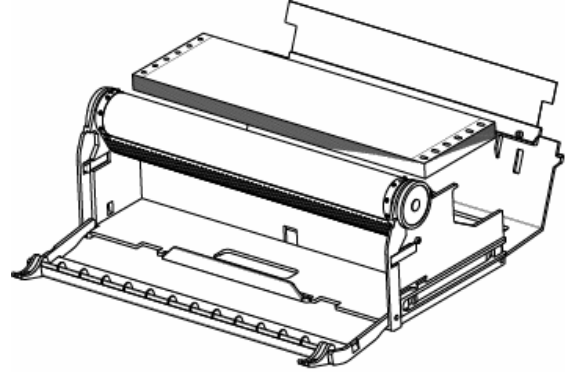

- ② Chart rack unit

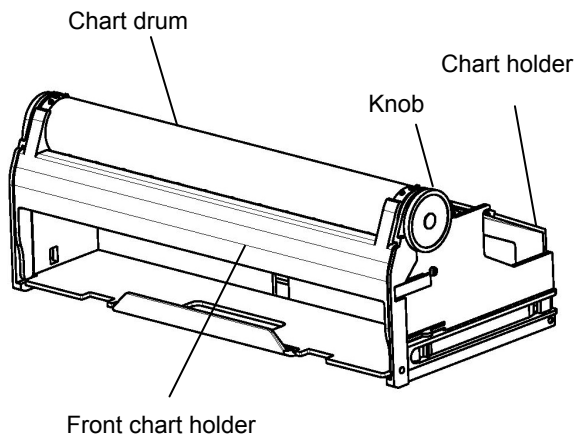

- ⑤ Fit the holes at both ends of the chart to the chart drum sprocket. After setting the chart, reset the front chart holder and chart holder to their original positions from being tilted down conditions in ③.

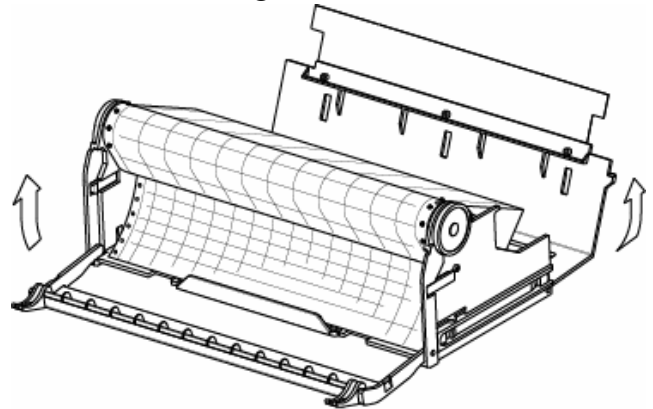

- ③ Pull down the front chart holder and chart holder before setting the chart.

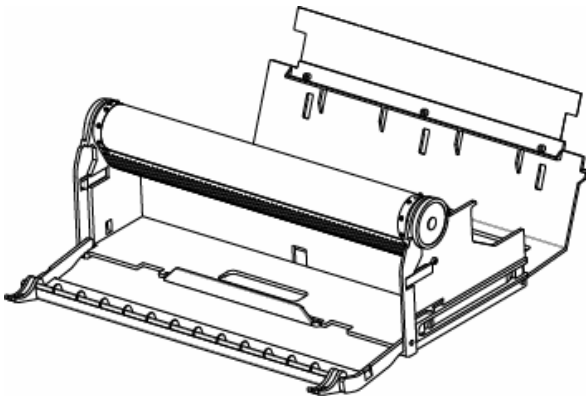

- ⑥ Mount the chart rack unit to the chassis, and fold the chart by 2-3 by turning the knob by means of fingers. In this case, set the chart fold to meet the convex and concave marks at the right end of the chart.

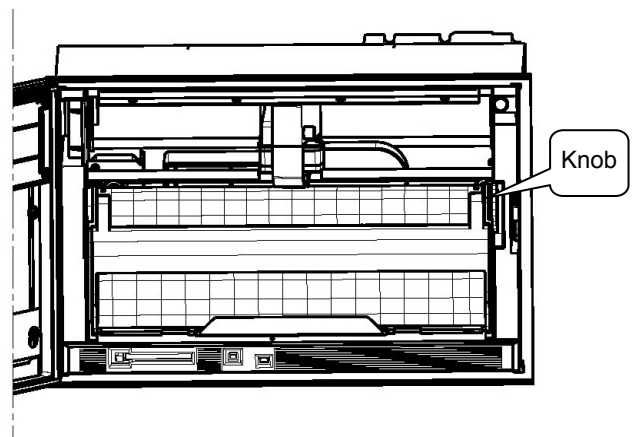

5-2 Ribbon cassette mounting method

- ① Prepare the ribbon cassette. Loosen the ribbon cassette about 10mm by pressing it in the arrow direction using the shaft of a ball-point pen or the like.

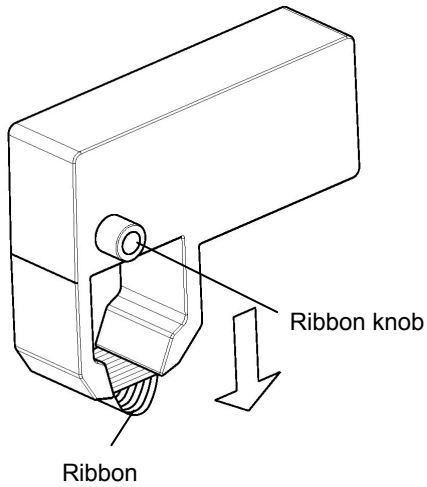

- ④ Keep the printer carriage unmovable by pressing it with the left hand, and mount the ribbon cassette in the arrow direction by the right hand.

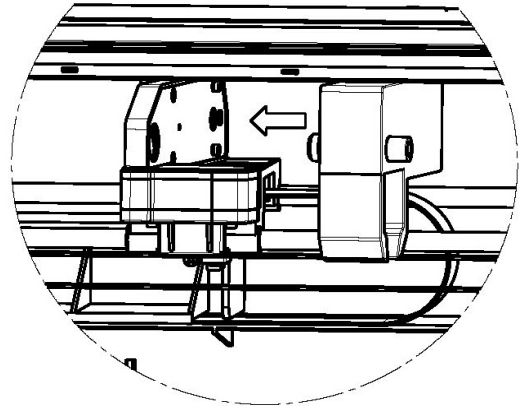

- ② After opening the door, turn off the power switch and draw out the chart.

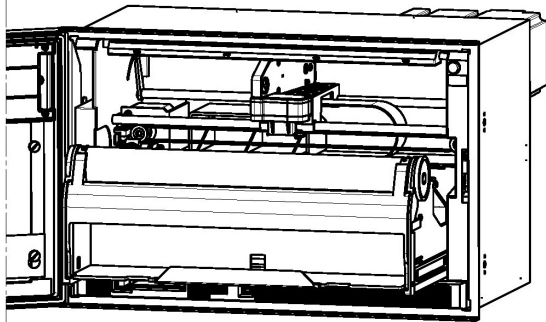

- ⑤ Refer to the top view shown below. The ribbon cassette is mounted diagonally as illustrated below. Make sure that face A of the printer carriage and face B of the ribbon cassette are mounted without any clearance. When the ribbon cassette is mounted completely, a click is heard by the locker spring.

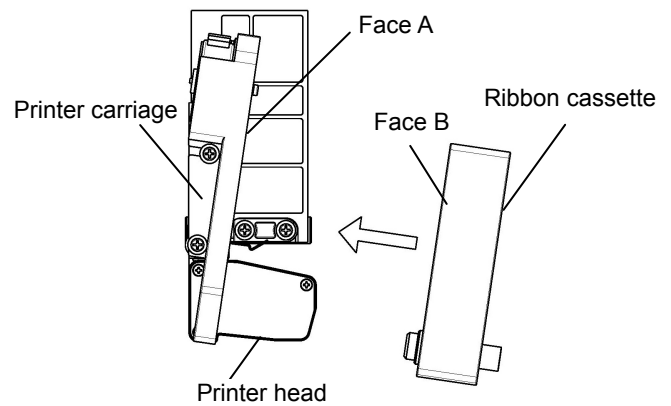

- ③ Move the printer carriage to about the center by hand.

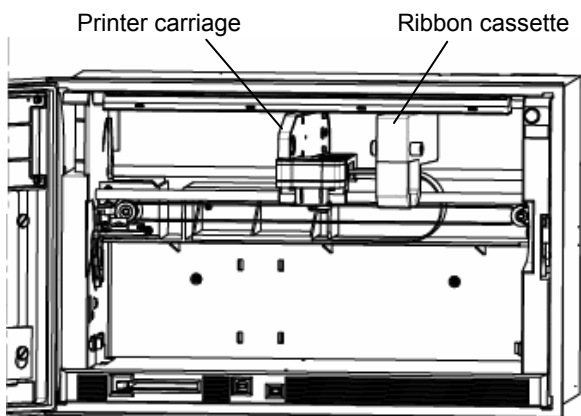

- ⑥ After the ribbon cassette has been mounted normally, straighten the ribbon by turning the ribbon knob clockwise 1-2 turns. Reset the chart rack unit to the chassis.

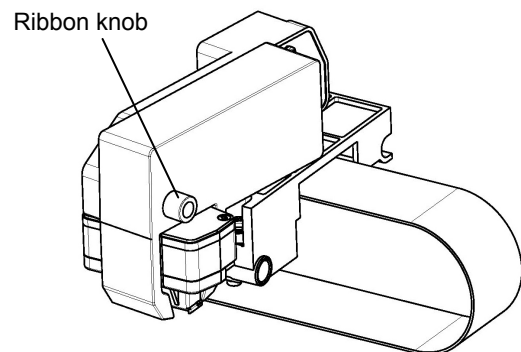

6. Operation

6-1 Turning on the power supply

- 1) Confirm the connections.
- 2) After opening the door, turn on the power switch at the upper right of the chassis.

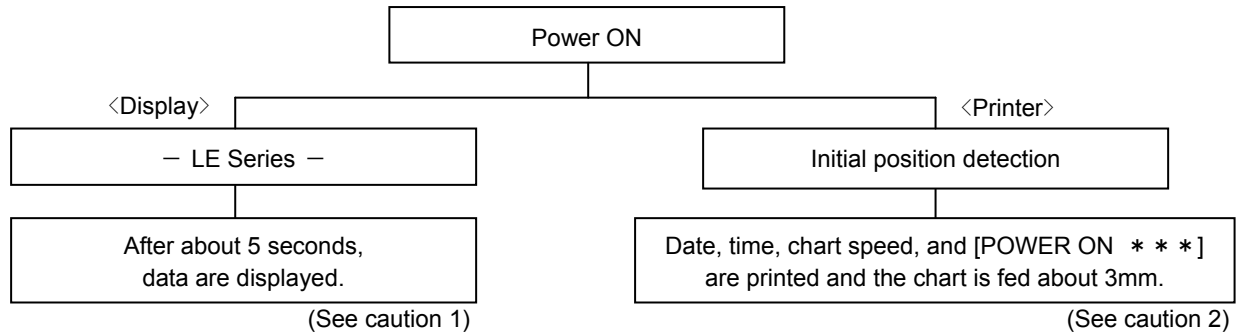

(Caution 1) Setting information and clock are backed up. Also, the display mode is backed up, but the channel number is not backed up. Accordingly, the range-set lowest channel number data are displayed in case of one-point continuous display. In the same way, data are displayed starting with the range-set lowest channel number in case of the multi-point sequential display. Also, data are displayed by turning on the power supply again after turning it off once under the setting check condition.

(Caution 2) If recording is turned off, a date (year, month, day) is not printed when turning on the power supply.

6-2 Display mode selection

This unit provides 6 kinds of display modes, although this depending upon the number of input points.

- 1) Each measuring data is fixed and displayed every channel.
- 2) Each measuring data is sequentially displayed every channel.
- 3) All input points are displayed collectively. (12-point collective display in case of 12-point unit, 24-point collective display in case of 24-point unit, 36-point collective display in case of 36-point unit)
- 4) 12-point measuring data are collectively fixed and displayed. (24-point and 36-point units excluding 12-point unit)
- 5) 12-point measuring data are collectively and sequentially displayed. (24-point and 36-point units excluding 12-point unit)
- 6) Type code, serial number, software version number of this unit are displayed.

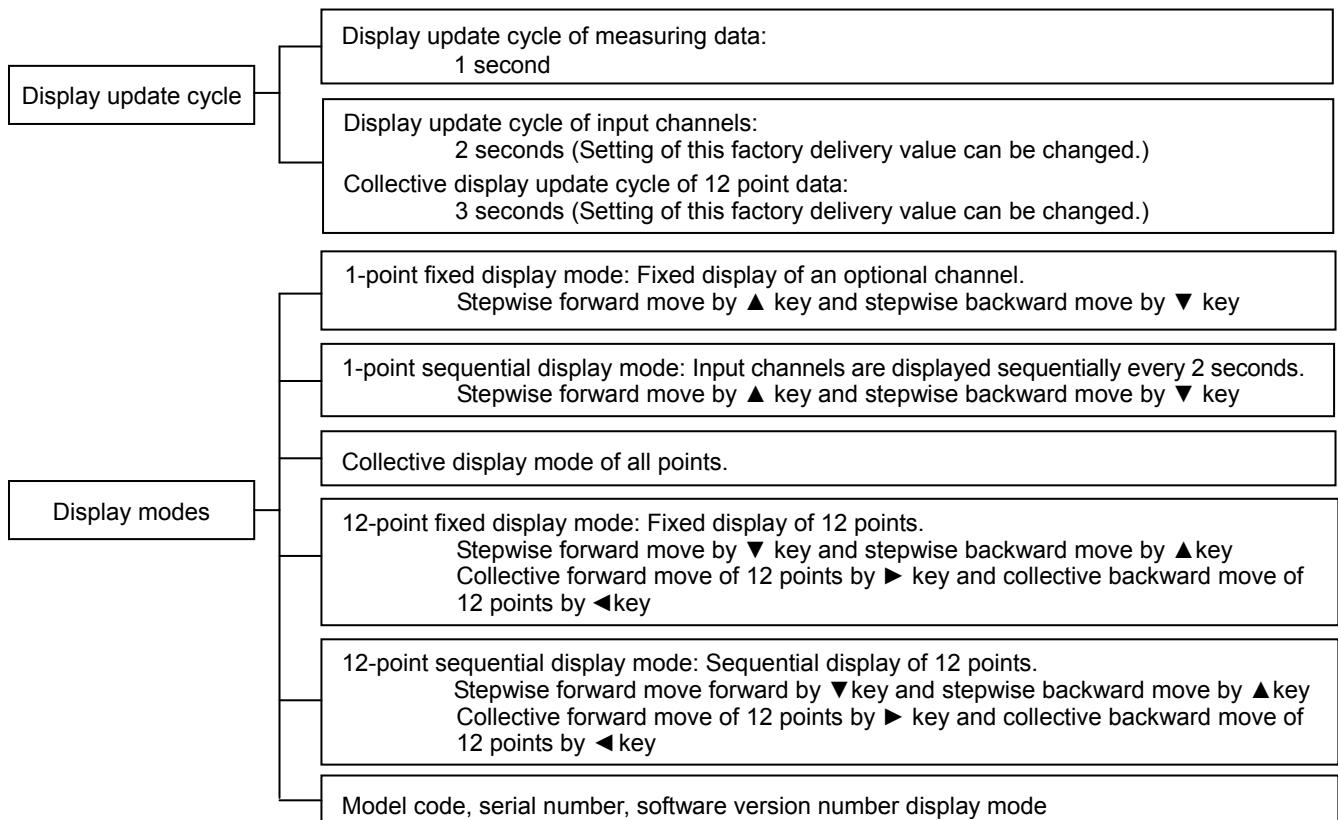

6-3 Recording operation

1) Recording ON-OFF

Recording can be turned on and off by Rec key and Enter key.

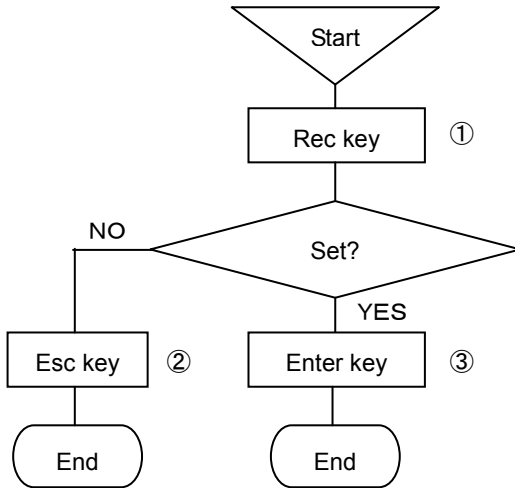

- ① By pressing Rec key under Rec. ON condition, a message [Do you terminate chart recording?] is displayed on the display unit. By pressing Rec key under Rec. OFF condition, a message [Do you start chart recording?] is displayed on the display unit.
- ② For stopping the setting, the screen returns to the last one, each time Esc key is pressed once.
- ③ Terminate the setting by pressing Enter key. ON and OFF are switched from each other by pressing Enter key.

(Caution 1)

REC. ON green LED lights in the status display unit under the recording ON condition.

(Caution 2)

Recording is stopped under the recording OFF condition, but the input entry, data update, and alarm, etc. operation are executed.

(Caution 3)

The following functions are not employable under the recording OFF condition.

- Data printing
- List printing
- Logging recording

2) Data printing

Latest measuring data are digitally recorded by interrupting the present analog recording.

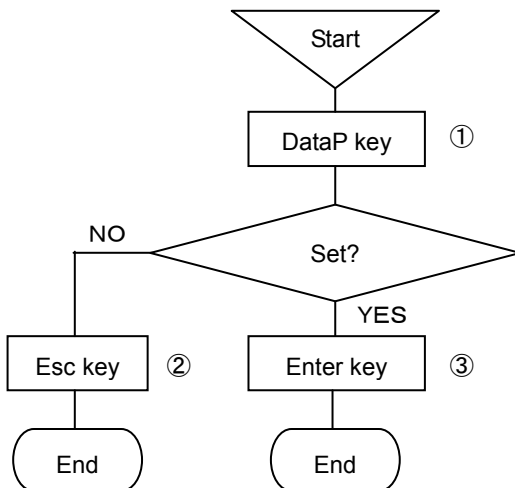

- ① By pressing DataP key, a message [Do you start data printing ?] is displayed on the display unit.
- ② For stopping the setting, the screen returns to the last one, each time Esc key is pressed once.
- ③ Terminate the setting by pressing Enter key. By pressing Enter key, the latest scan data at that time are digitally recorded.

(Caution 1)

Format is set by [DATA PRINT] of the menu.

(Caution 2)

If digital recording is necessary at a fixed interval, use either data interval recording or logging recording.

(Caution 3)

Not employable under the recording OFF condition.

Two kinds of digital recording formats are available. These formats can be set optionally according to uses.

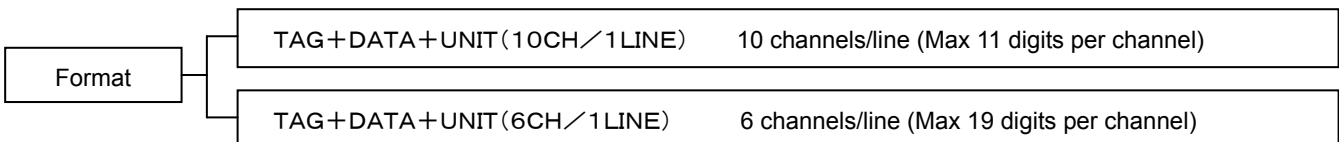

3) Chart feed

The chart (recording paper) can be fed by Feed key.

The chart is fed at a speed of 750mm/min when Feed key is being pressed.

Use this function when measured objective and/or measuring conditions have been changed. The chart can also be fed manually by the knob. However, it is possible that the chart is not fed by several mm due to a mechanical reason of this unit. It is, therefore, recommended to feed the chart by Feed key. **Feed the chart by Feed key due to the same reason when a new chart has been mounted.**

7. Initial setting at the delivery time from the factory

7-1 Setting items at the delivery time from the factory

Items	Initial setting items																						
(1) Time	Present time (year, month, day, Japanese time)																						
(2) Range	<table border="1"> <thead> <tr> <th>Item</th> <th>Models</th> <th>LE5100/LE5200</th> </tr> </thead> <tbody> <tr> <td rowspan="3">(2) Range</td> <td>① Input type</td> <td>V(-10.000 to 10.000)</td> </tr> <tr> <td>② RJ</td> <td>Not provided (external)</td> </tr> <tr> <td>③ Analog recording range</td> <td>-10.000 to 10.000</td> </tr> <tr> <td>(3) Scale</td> <td></td> <td>-10.000 to 10.000</td> </tr> <tr> <td>(4) Unit</td> <td></td> <td>V</td> </tr> </tbody> </table>	Item	Models	LE5100/LE5200	(2) Range	① Input type	V(-10.000 to 10.000)	② RJ	Not provided (external)	③ Analog recording range	-10.000 to 10.000	(3) Scale		-10.000 to 10.000	(4) Unit		V						
Item		Models	LE5100/LE5200																				
(2) Range		① Input type	V(-10.000 to 10.000)																				
		② RJ	Not provided (external)																				
		③ Analog recording range	-10.000 to 10.000																				
(3) Scale		-10.000 to 10.000																					
(4) Unit		V																					
(3) Scale																							
(4) Unit																							
(5) Tag number	* 01 - * <input type="checkbox"/> <input type="checkbox"/> <input type="checkbox"/> Channel number <ul style="list-style-type: none"> ① Model LE511 : *001 - *012 ② Model LE512 : *001 - *024 ③ Model LE513 : *001 - *036 																						
(6) Skip	① Display skip : Not set in all channels ② Digital printing skip : Not set in all channels ③ Memory card recording skip : Not set in all channels																						
(7) Chart speed	25mm/h Dotting cycle : Chart speed interlocking cycle																						
(8) Scan cycle (Input entry cycle)	Automatic development value of chart speed (28.8sec)																						
(9) Digital recording format	① Data interval (Data I) : Not set ② Logging recording : Not set ③ Data printing (Data P) : 1 line/6 channels printing																						
(10) Analog recording format	① Format : Standard ② Recording colors <table border="1" style="margin-top: 10px;"> <thead> <tr> <th>Channel numbers</th> <th>Recording colors</th> </tr> </thead> <tbody> <tr><td>1・11・21・31・41・51・61・71</td><td>Green</td></tr> <tr><td>2・12・22・32・42・52・62・72</td><td>Yellowish green</td></tr> <tr><td>3・13・23・33・43・53・63</td><td>Orange</td></tr> <tr><td>4・14・24・34・44・54・64</td><td>Red</td></tr> <tr><td>5・15・25・35・45・55・65</td><td>Reddish purple</td></tr> <tr><td>6・16・26・36・46・56・66</td><td>Brown</td></tr> <tr><td>7・17・27・37・47・57・67</td><td>Bluish green</td></tr> <tr><td>8・18・28・38・48・58・68</td><td>Purple</td></tr> <tr><td>9・19・29・39・49・59・69</td><td>Bluish purple</td></tr> <tr><td>10・20・30・40・50・60・70</td><td>Black</td></tr> </tbody> </table> <ul style="list-style-type: none"> ● Channels 37 - 72 are mounted as auxiliary channels. They are used as differential recording channels, etc. ● Recording colors are those in initial setting and they can also be designated optionally. 	Channel numbers	Recording colors	1・11・21・31・41・51・61・71	Green	2・12・22・32・42・52・62・72	Yellowish green	3・13・23・33・43・53・63	Orange	4・14・24・34・44・54・64	Red	5・15・25・35・45・55・65	Reddish purple	6・16・26・36・46・56・66	Brown	7・17・27・37・47・57・67	Bluish green	8・18・28・38・48・58・68	Purple	9・19・29・39・49・59・69	Bluish purple	10・20・30・40・50・60・70	Black
Channel numbers	Recording colors																						
1・11・21・31・41・51・61・71	Green																						
2・12・22・32・42・52・62・72	Yellowish green																						
3・13・23・33・43・53・63	Orange																						
4・14・24・34・44・54・64	Red																						
5・15・25・35・45・55・65	Reddish purple																						
6・16・26・36・46・56・66	Brown																						
7・17・27・37・47・57・67	Bluish green																						
8・18・28・38・48・58・68	Purple																						
9・19・29・39・49・59・69	Bluish purple																						
10・20・30・40・50・60・70	Black																						
(11) Dots	All OFF																						
(12) Alarm setting	Not set																						
(13) Differential recording setting	Not set																						
(14) Message setting	Not set																						
(15) Password setting	3571																						

7-2 Mode change by soft switch

The LE5000 series is able to select ON/OFF (show/not show) of various printing by initial settings. Refer to below for setting as required. Initial setting in factory delivery is all [ON].

1. Indication method of setting screen

When turn on the power supply of instrument, [LE Series] is displayed in the display screen. Enter [332] by setting key of recorder while [LE Series] is displayed.

2. Detail setting

When enter [332], display a screen like below, so setup according to the following procedure.

ON	ON	ON	ON	ON	ON	ON	ON
7	6	5	4	3	2	1	0
7 : Print of time							
6 : Print of scale							
5 : Print of alarm							
4 : Print of range no.[auto range]							
3 : Print of tag							
2 : Time line							
1 : Alarm line							
0 : ON [Japanese] / OFF [English]							
							SET

7	Time printing ON/OFF
6	Scale printing ON/OFF
5	Alarm activation/reset printing
4	Range No. printing ON/OFF at automatic range switch
3	Tag printing ON/OFF
2	Time line printing ON/OFF
1	Alarm activation/cancellation mark printing ON/OFF
0	Switch Japanese/English in setting screen

When select [7] to [0] by ◀▶ key, and then press [enter] key, ON/OFF are switched every pressing [enter] key. After every selects are done, cursor is moved to [SET] by ◀▶ key, and press [Enter] key to terminate the setting.

8. Setting and changes by key operation

8-1 Basic rules

Read these rules without fail before starting setting

This paragraph describes general common items in setting operation.

1. Setting items and setting parameters

In measurement and recording, versatile recording results and data are obtained according to various conditions setting of this unit.

Measuring and recording conditions such as the range, speed, chart speed, etc are called setting items. Individual definite contents of these setting items are called setting parameters or merely parameters.

2. Calling of setting items

All calling is started with Menu key. By pressing Menu key, various setting items are displayed. Select a setting item by ◀·▶·▲·▼ keys and define it by Enter key. Certain setting items are displayed over several hierarchies.

3. Calling of setting parameters

When the items to be set are defined, a window opens to be ready for setting the setting parameters.

4. Acceptance and acceptance failure of keys

If the cursor does not move by ◀·▶·▲·▼ keys or the parameter setting window is not opened by Enter key, it is caused by an acceptance failure. Check if these keys are pressed securely.

5. No. of parameters by setting items

Number of setting parameters depends upon the setting items. One parameter is provided for time and chart speed, while several parameters requiring the designation of channels are provided for ranges, scales, and alarms.

6. Confirmation of setting parameters

Setting parameters can be set in two ways. One is the list printing to confirm all setting items or designated setting items by printing them, while the other is the display confirmation to confirm the setting parameters by calling them to the display section. The **[Display confirmation]** method will be described here.

For the [List printing], refer to 8-9.

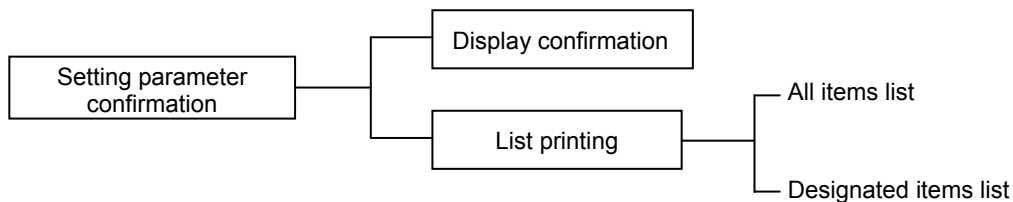

When plural setting parameters are called, the preset lowest channel number is displayed.

After designating the channel number to be confirmed, press Enter key, and parameters of the channel are displayed.

For confirming the other channel, return to the last screen by Esc key, select the channel by ◀·▶·▲·▼ keys, and press Enter key again to display the parameters of the channel.

If setting (change, addition) is not executed, irrespective of the number of setting parameters, press Esc key, and the screen returns to the last one. Continue pressing Esc key until the mode returns to the normal display mode.

1. Confirmation method in case of one setting parameter

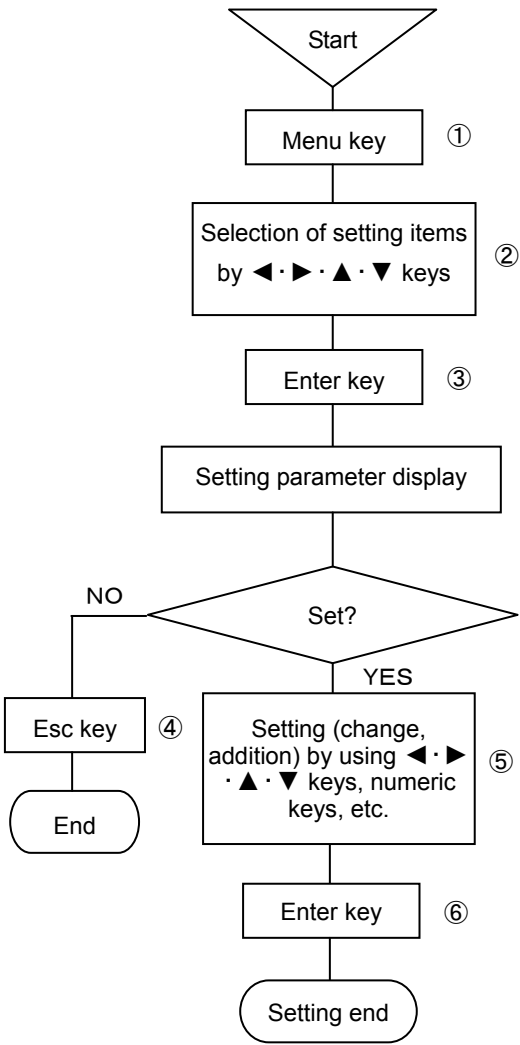

- ① Select the setting display mode by pressing Menu key. A window opens to display a list of setting items.
- ② Move the cursor by ◀ · ▶ · ▲ · ▼ keys and select an item to be confirmed.
- ③ Select the setting mode of the desired setting item by pressing Enter key. A window opens to display various setting parameters.
- ④ If setting (change or addition) is not done after confirming various setting parameters, return to the last screen by pressing Esc key. In case of the left procedure example, the screen is reset to the start screen by pressing Esc key twice.
- ⑤ If setting (change or addition) is done after confirming various setting parameters, use ◀ · ▶ · ▲ · ▼ keys and numeric keys.
- ⑥ Press Enter key to terminate the setting (change, addition).

2. Confirmation method in case of plural setting parameters

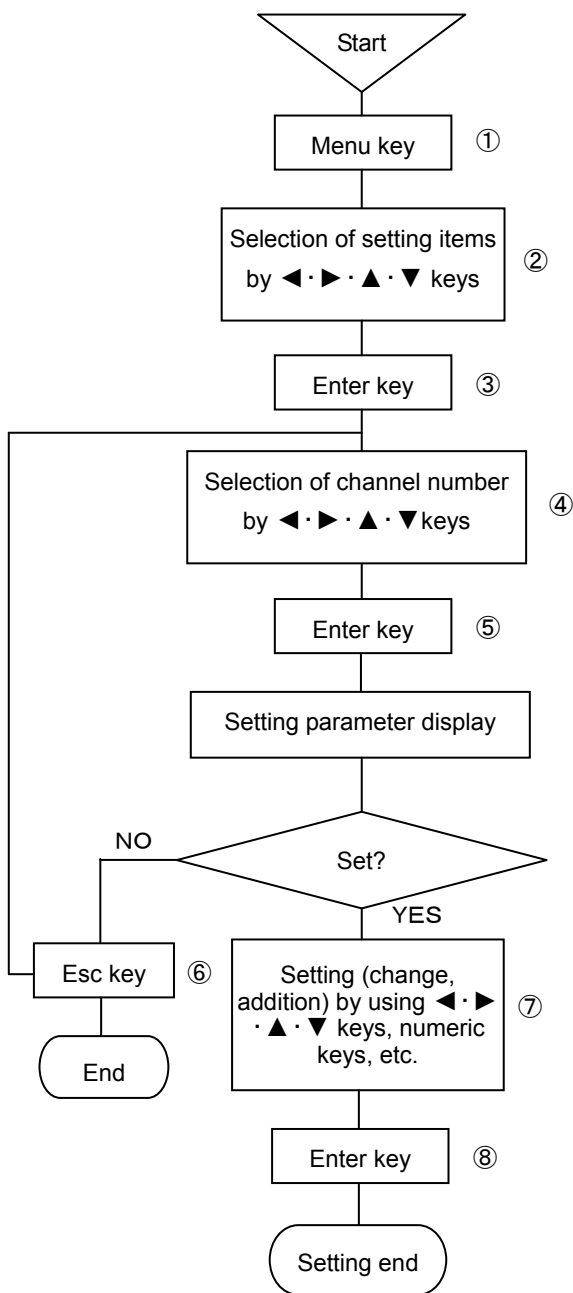

- ① Select the setting display mode by pressing Menu key. A window opens to display a list of setting items.
- ② Move the cursor by ◀·▶·▲·▼ keys and select an item to be confirmed.
- ③ Select the setting mode of the desired setting item by pressing Enter key. A window opens to display channel numbers.
- ④ Move the cursor by ◀·▶·▲·▼ keys and select a channel to be confirmed.
- ⑤ Select the setting mode of the desired setting item by pressing Enter key. A window opens to display various setting parameters.
- ⑥ For advancing the channel forward or backward after confirming the setting parameters of the channel to be confirmed, press Esc key to return to the last screen, and repeat steps ④-⑥. Press Esc key if setting (change, addition) is not done. In case of the left procedure example, the screen is reset to the start screen by pressing Esc key twice.
- ⑦ If setting (change or addition) is done after confirming various setting parameters, use ◀·▶·▲·▼ keys and numeric keys.
- ⑧ Press Enter key to terminate the setting (change, addition).

7. Setting change

For setting change, shift the cursor to a desired point to be changed.

For moving the selection system parameters by cursor, ▲·▼ keys are used. However, ◀·▶ key is normally used. Setting can be changed by the substitution method, edition method by shifting the cursor, and new setting method after erasing all setting.

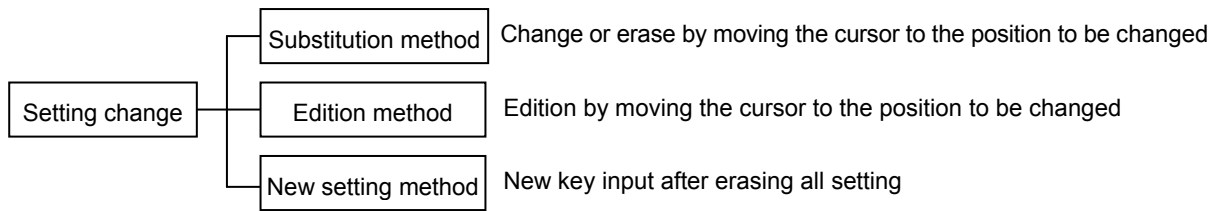

1) Substitution method

Select a setting parameter to be changed. The selected setting parameter is high-lighted like 1 5 0. Input the parameter by keys directly after the selected setting parameter has been high-lighted as shown in the example.

2) Edition method

Select a setting parameter to be changed. The selected setting parameter is high-lighted like 1 5 0. Press ◀·▶ key after the selected setting parameter has been high-lighted as shown in the example.

The high-lighting is reset and 1 5 0 | cursor is displayed.

Edit the parameter by shifting the displayed cursor using ◀·▶ key.

By pressing Esc key under the 1 5 0 | condition, 1 5 0 | returns to 1 5 0.

▲ key serves as the back space key while ▼ key serves as the delete key in this edition mode.

3) New setting method

Select a setting parameter to be changed. The selected setting parameter is high-lighted like 1 5 0.

Erase the setting parameter by using ▲ key (back space key) or ▼ key (delete key) after the selected setting parameter has been high-lighted as shown in the example. Then, input new parameter directly.

8. Switching of keys

When alphabetic keys or symbol keys are used, switch them by pressing [Shift] key.

This switching can be done only when alphabetic or symbol keys are necessary for [Units], [Tags], [Messages], etc.

(Example: Setting of message printing)

RECORD ON 100mm/h 2005/06/14 16:47:36

Menu

Message

Ch.

Message

Set

Shift : Num./Alphanum. 1 A

By pressing [Enter] key after bringing the cursor to the message, Shift: numeric characters/alphanumeric characters are displayed at the lower part of the display. If [1] is high-lighted, numeric keys only can be input. When [Shift] is pressed, [A] is high-lighted to be ready for inputting alphanumeric characters.

When [A] is high-lighted, [1 ABC] key is switched in the order of 1 → A → B → C → a → b → c → 1.

9. Setting change mark

When a setting parameter is entered, a setting change mark is printed at the right end of the chart.

A changed item is printed on the right side of [◀] as a setting mark.

For changing each channel, [◀S] is printed in case of [◀C] system (chart speed, etc.).

10. Setting define function

By pressing Enter key, the setting contents are checked by the unit. If an error occurs when checking the setting contents, the status part at the lower part of the display turns red, and the error contents are displayed.

11. Basic entry of setting parameters

When various setting parameters are entered, a window opens to display a setting parameter entry screen. The basic common operation in the setting parameter entry screen is as shown below.

Example 1: Chart recording setting screen; In case of selection of setting parameters by ▲ · ▼ keys.

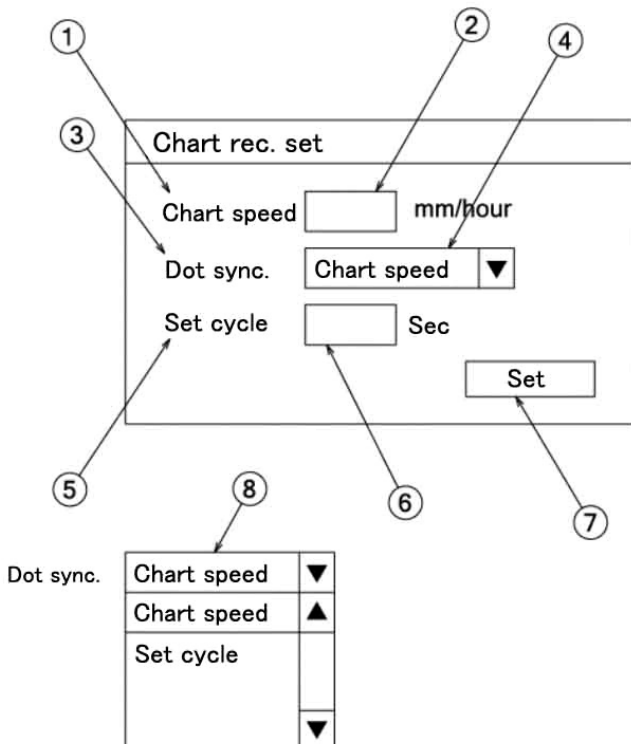

- ①, ③, ⑤, and ⑦ are called a setting item, while ②, ④, and ⑥ are called a parameter input area.
- When the setting parameter entry screen is displayed, chart speed ① is high-lighted (A cursor is present on the chart speed). Set the cursor to meet the dot synchronization by ▲ · ▼ · ◀ · ▶ keys under the above condition. Press Enter key. Parameter input area ④ is high-lighted to be ready for selection (input).
- A window as shown in ⑧ is displayed when selecting setting parameters as shown in this example. Select a setting parameter by using ▲ · ▼ keys in this window. For setting the chart speed, bring the cursor to meet the chart speed by ▲ · ▼ keys and press Enter key.
- By pressing Enter key after setting the parameter input area ④, optional cycle ⑤ is high-lighted. By pressing Enter key under this condition, parameter input area ⑥ is high-lighted to be ready for input.
- By pressing Enter key after parameter input area ⑥ has been set, define ⑦ is high-lighted. When no error occurs in setting parameters of all setting items, press Enter key, and the setting ends.
If a setting item is in error to move to the other setting item, press ▲ · ▼ keys, and the move can be done to each setting item on condition that Enter key is not pressed yet.

(Point 1)

When the cursor is present on a setting item, the setting item can move to individual setting items by ▲ · ▼ · ◀ · ▶ keys.

Example 2: Display mode setting screen; In case of inputting a setting parameter by using keys

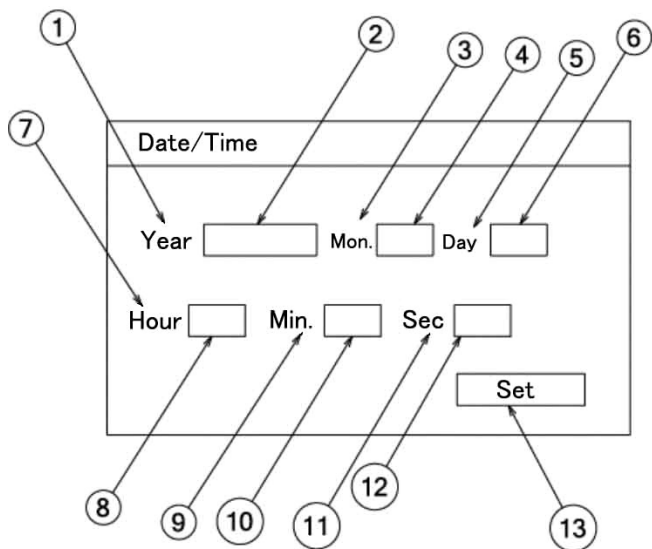

1. When the setting parameter entry screen is displayed, AD ① is high-lighted. (The cursor is present on AD) By pressing Enter key under this condition, parameter input area ② is high-lighted to be ready for input.
2. Input a setting parameter by numeric keys, etc. under the high-lighted condition of parameter input area ②. Cursor [|] in the parameter input area can be moved by ◀ • ▶ key under this condition. Press Enter key after the end of input.
3. By pressing Enter key after setting the parameter input area ②, month ③ is high-lighted. By pressing Enter key after parameter input area ⑫ has been set in the same way, define ⑬ is high-lighted. When no error occurs in setting parameters of all setting items, press Enter key, and the setting ends. If a setting item is in error to move to the other setting item, press ▲ • ▼ keys, and the move can be done to each setting item on condition that Enter key is not pressed yet.

(Point 1)

When the cursor is present on a setting item, the setting item can move to individual setting items by ▲ • ▼ • ◀ • ▶ keys.

(Point 2)

By pressing ◀ key or ▶ key when the parameter input area is high-lighted, cursor [|] is displayed in the parameter input area to be ready for moving by ◀ • ▶ key.

(Point 3)

When cursor [|] is displayed in the parameter input area to be ready for moving by ◀ • ▶ key, ▲ key serves as Back Space key, while ▼ key serves as Delete key. (This is not applicable if the parameter input area adopts the selection method.)

8-2 Display setting

This unit comprises 4 kinds of display modes. The present display mode is [12CH], but the other display mode is settable as occasion demands.

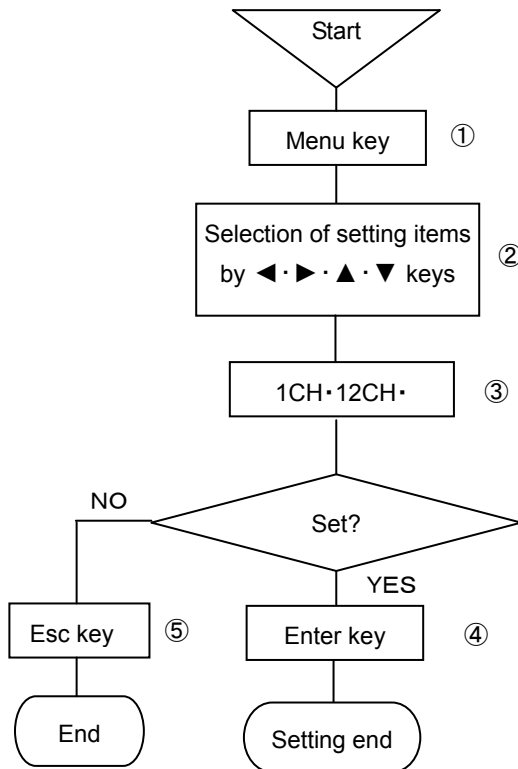

- ① Select the setting display mode by pressing Menu key. A window opens to display a setting items table.
- ② Move the cursor by ◀·▶·▲·▼ keys and select an item to be confirmed.
- ③ Select 1CH, 12CH, or 36CH.
- ④ After selection, the desired display mode to be set is defined. Either fixed display or sequential display is selectable in each display mode.
(AUTO: Sequential/CONST: Fixed are switched from each other, each time Func1 key is pressed once.)
- ⑤ For stopping the setting, the screen returns to the last one, each time Esc key is pressed once.

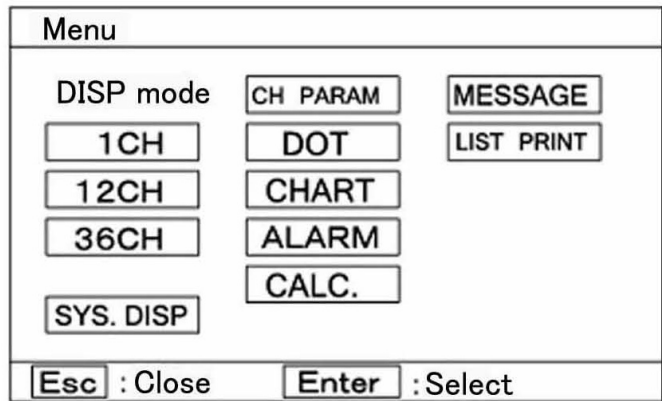

A list of the kinds of display

1	1CH	1-point fixed display
2	1CH	1-point sequential display
3	12CH	12-point fixed display
4	12CH	12-point sequential display
5	1·12·36CH	All-point fixed display
6	1·12·36CH	All-point sequential display

(Caution 1)

If skip is designated, data in skip designation channels are not displayed.

(Caution 2)

The update cycle of data display is 1 second, and the input loading cycle is 0.1 second fixation. The data update cycle and the input loading cycle are not synchronized.

(Caution 3)

Channels can be moved forward or backward by ◀·▶·▲·▼ keys even in case of the sequential display mode.

(Caution 4)

By turning off the power supply, the one-point fixed display mode is held, but the data display channel number is reset to the lowest channel number in range setting.

Display mode

Tag	Channel number + Range + Measuring data + Tag
Unit	Channel number + Range + Measuring data + Unit

For details, refer to 8-13 [Display].

- ※) If 1CH display is set, the display mode is limited to one kind of [Channel number + Tag + Measuring data + Range + Unit].
- ※) If SYS.DISPLAY is set, system information about this instrument is displayed. For details of display, refer to page 2-2.

8-3 Channel parameter setting [CH PARAM.]

Range, RJ (internal/external switching of reference junction temperature compensation), scale, unit, etc. of each channel can be set collectively every channel.

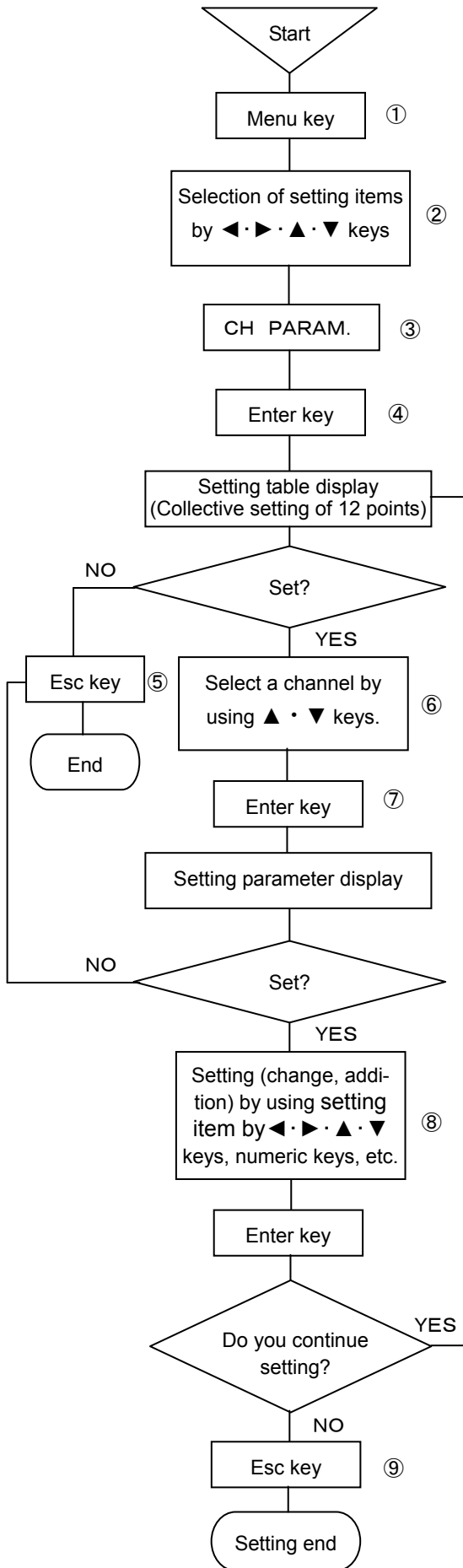

- ① Select the setting display mode by pressing Menu key. A window opens to display a setting items table.
- ② Move the cursor by ◀·▶·▲·▼ keys and select an item to be confirmed.
- ③ Select CH PARAM.
- ④ Press Enter key to enter the setting table display. (For the setting table display (collective 12 points) screen, refer to ⑥.)
- ⑤ For stopping the setting, the screen returns to the last one each time Esc key is pressed once.
- ⑥ Move the cursor to a desired channel number to be set by ▲·▼ keys. The cursor does not move to any item other than CH No.

RECORD ON		100mm/h		2005/06/14 10:33:28						
CH	Input	RJ	Range		Scale		Unit	Burn	Corr.	Filter
			MIN	MAX	MIN	MAX				
CH001	V	Ext.	-10.000	+10.000	-10.000	+10.000	V	None	0.0	None
CH002	V	Ext.	-10.000	+10.000	-10.000	+10.000	V	None	0.0	None
CH003	V	Ext.	-10.000	+10.000	-10.000	+10.000	V	None	0.0	None
CH004	V	Ext.	-10.000	+10.000	-10.000	+10.000	V	None	0.0	None
CH005	V	Ext.	-10.000	+10.000	-10.000	+10.000	V	None	0.0	None
CH006	V	Ext.	-10.000	+10.000	-10.000	+10.000	V	None	0.0	None
CH007	V	Ext.	-10.000	+10.000	-10.000	+10.000	V	None	0.0	None
CH008	V	Ext.	-10.000	+10.000	-10.000	+10.000	V	None	0.0	None
CH009	V	Ext.	-10.000	+10.000	-10.000	+10.000	V	None	0.0	None
CH010	V	Ext.	-10.000	+10.000	-10.000	+10.000	V	None	0.0	None
CH011	V	Ext.	-10.000	+10.000	-10.000	+10.000	V	None	0.0	None
CH012	V	Ext.	-10.000	+10.000	-10.000	+10.000	V	None	0.0	None

ESC : Close Enter : Ch.set Func1 : Next Func2 : Copy AUTO

- ⑦ Select a channel to be set and press Enter key. A window opens to display a setting parameter entry screen. (For the setting parameter entry screen, refer to ⑧.)
- ⑧ Move the cursor to a desired item to be set by ◀·▶·▲·▼ keys.

CH .set		CH001					
Input	<input type="text"/>	RJ	<input type="text"/>	Burn	<input type="text"/>	Filter	<input type="text"/>
Range MIN	<input type="text"/>	Range MAX	<input type="text"/>	Scale MIN	<input type="text"/>	Scale MAX	<input type="text"/>
Scale MIN	<input type="text"/>	Scale MAX	<input type="text"/>	Corr.	<input type="text"/>	Unit	<input type="text"/>
Record MIN	<input type="text"/>	Record MAX	<input type="text"/>	Tag	<input type="text"/>		
Display skip	<input type="text"/>	Digital printing skip	<input type="text"/>				
Memory card rec. skip	<input type="text"/>						<input type="text"/>

Set

The cursor moves in the sequence of Input → RJ → Burn → Filter → Range MIN → Range MAX → Scale MIN → Scale MAX → Correction → Unit → Lower-limit of chart recording → Higher-limit of chart recording → Tag → Display skip → Digital printing skip → Memory card recording skip → Set, each time Enter key is pressed once.

CH No. is fixed to the channel number selected in the setting table display (collective 12 points) screen. For the parameter input areas for input, RJ, burn, filter and various skips, setting parameters are selected. Select them by ▲·▼ keys after the window has opened. For the MIN and MAX of Range, correction, MIN and MAX of scale, and MIN and MAX of chart recording, input their setting parameters by using numeric keys. For the unit and tag, input their setting parameters by using numeric keys or other keys.

After the end of setting in this screen, bring the cursor to Set .

- ⑨ Terminate the setting (change, addition) by pressing Enter key. Press Esc key if the setting contents are not saved.

- ⑩ By pressing Func1 in the screen display in ⑥ above, the following screen is displayed. Screens ⑥, ⑩ are used for confirming the setting and copying the setting items in the setting screen to the other channels.

RECORD ON		100mm/h		2005/06/14 10:33:28			
CH	Tag	Record		Skip			
		MIN	MAX	Display	Digital	Logging	M-card
CH001		-10.000	+10.000	Off	Off	Off	Off
CH002		-10.000	+10.000	Off	Off	Off	Off
CH003		-10.000	+10.000	Off	Off	Off	Off
CH004		-10.000	+10.000	Off	Off	Off	Off
CH005		-10.000	+10.000	Off	Off	Off	Off
CH006		-10.000	+10.000	Off	Off	Off	Off
CH007		-10.000	+10.000	Off	Off	Off	Off
CH008		-10.000	+10.000	Off	Off	Off	Off
CH009		-10.000	+10.000	Off	Off	Off	Off
CH010		-10.000	+10.000	Off	Off	Off	Off
CH011		-10.000	+10.000	Off	Off	Off	Off
CH012		-10.000	+10.000	Off	Off	Off	Off

ESC : Close Enter : Ch.set Func1 : Previous Func2 : Copy AUTO

For returning to screen ⑥ from screen ⑩, press Func1 key again.

Screen ⑧ can also be displayed by pressing Enter key after moving the cursor to a desired channel number to be set by ▲ · ▼ keys in this screen.

- ⑪ For copying channel parameters to the other channel, press Func2 key in either screen ⑥ or ⑩.
- ⑫ Move the cursor to a desired item to be copied by ◀ · ▶ · ▲ · ▼ keys.

Setting copy

Input, RJ, Range, Scale, Burn Unit Corr. Filter

Tag Record range

Display skip Digital rec. skip Memory card skip

Memory card rec. skip

Source Dest. ~

Each time Enter key is pressed once, [L]/[] is repeated.

Select [L] for a desired setting item to be copied, and select [] for a setting item to be not copied. Press Enter key after moving the cursor to the copy source.

After inputting a desired channel number as the copy source by numeric keys, press Enter key, and the cursor moves to the copy destination. By pressing Enter key furthermore, the channel number at the copy destination can be input by numeric keys.

By pressing Enter key after inputting a channel number at the copy destination, the cursor moves to [~]. Press Enter key, and the channel number at the copy destination can be input by numeric keys.

After the end of setting on this screen, bring the cursor to .

- ⑬ Terminate the copy by pressing Enter key.

- ※) When the input kind, scale lower-limit, and scale higher-limit are changed in the setting of a channel parameter, other settings (set value, dead band etc.) may be influenced.
- ※) Resolution of analog recording depend on setting value of scale lower-limit/higher-limit, not depend on setting of chart recording lower-limit/higher-limit.

[Points] Channel parameter setting short-cut

Items ①-⑥ on the last page can be short cut so long as the channel parameter setting is concerned. Bring the cursor to a desired channel to be set by ◀ · ▶ · ▲ · ▼ keys in each display mode of one-point display, 12-point collective display, or all-point collective display, and then, press Enter key.

Screen ⑧ on the last page is displayed and the setting can be done by the same operation.

- In case of one-point display, no cursor is displayed, but the channel in which Enter key was pressed can be set.
- In 12-point collective display/all-point collective display, the cursor is present on a channel number. Move the cursor by pressing ◀ · ▶ · ▲ · ▼ keys.
- When the channel parameter setting short-cut was used, no copy function is provided on the setting screen.
- For setting [°C], bring the cursor to the unit, and press the Enter key for enabling the parameter input. [Shift] is displayed below the setting screen (refer to page 8-4: 8. Switching of keys). Press the shift key and high-light [A], and press the key of right next shift key 4 times. Then, input C and press Enter key for termination setting unit.

[Setting example]

Setting relation of [Scale lower-limit], [Scale higher-limit], [Chart recording lower-limit] and [Chart recording higher-limit].

- Use K (-200.0 to 500.0) for input.
- Set [Scale lower-limit] to -200.0.
- Set [Scale higher-limit] to 500.0.
- Set [Chart recording lower-limit] to -100.0.
- Set [Chart recording higher-limit] to 300.0.

The recording range is reflected by each setting as shown in the following figure.

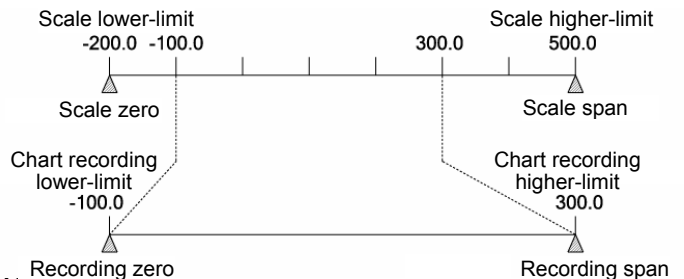

Range lower-limit and higher-limit, scale higher-limit and lower-limit, and chart recording lower-limit and higher-limit can be set up to max. 5 digits (or can be set up to max. 6 digits if minus [-] is included).

If a numeric value includes a decimal point, however, the numeric value excluding the decimal point is limited up to ±30000.

Example: Settable up to ±300.00

If 500.00 is set, a message [The input value is abnormal] is displayed and the setting is not acceptable. Units and tags can be set up to max. 8 digits.

(Caution 2)

For moving between channels, use ▲ · ▼ keys.

In the channel parameter setting mode, channels 1—12 are displayed. For moving to channels 13—24, move the cursor to channel 12, and press ▼ key. For moving to channels 1—12 under the displayed condition of channels 13—24, on the contrary, press ▲ key.

1. Operation recording

Operating conditions of peripheral units or the like are recorded at an optional position of the chart as operation recording. This function is provided as a relative recording function between system conditions and measuring data.

Max. 36 records can be marked on the chart.

Contact input	Data display	Digital recording	Analog recording	Communication output
Open	OFF	OFF	Designated position (range setting)	0
Short	ON	ON	2% (5mm) to the span (right) direction	1

Setting of position to 50% in chart recording lower-limit setting

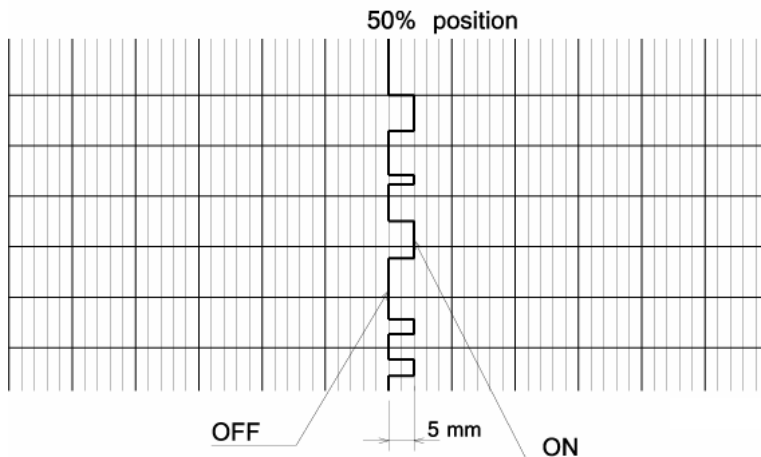

The chart recording lower-limit is set to [50] and the higher-limit is set to [52] at the delivery time from our factory as recording positions. By setting the chart recording lower-limit to an optional value, its set value +2 is automatically expanded as the higher-limit. Since the recording width can be changed optionally, the chart recording higher-limit value can be set optionally in the same way as in the lower-limit. If the chart recording higher-limit value is smaller than the lower-limit value ON/OFF recording positions are reversed.

[Note] When the parallel scale recording of recording format is used, the recording positions are % to the span of each area

【Setting method】

- 1) This operation is done by setting channel parameters. (I . Instruction Manual 8-2 [CH. PARAM.])
- 2) For input, select ON/OFF (1: ON / 0: OFF).
 Settable items are input chart recording lower-limit / higher-limit, unit, tag, display skip, digital printing skip, and memory card recording skip only. The cursor also moves to the other items, but no setting can be done.
- 3) Set the OFF recording position in units of % (every % step).
 Set the ZERO side of the chart to 0% and the SPAN side to 100%. For this setting, input them to the chart recording lower-limit / higher-limit setting parameter input area by numeric keys. The settable recording position range is 0 to 99%. (The higher-limit is MAX. 100%)
- 4) Unit, tag, and skip can be set in the same way as in normal input.

【Input connection】

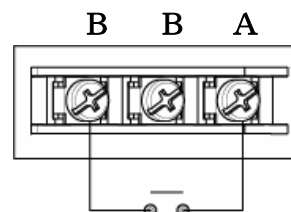
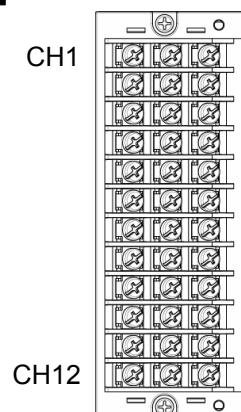

2. Data communication input

The “data communication input” is the function that records and calculates the data concurrently with measuring data which is sent from the host via the communication interface.

【Setting method】

- 1) This operation is done by setting channel parameters. (I . Instruction Manual 8-2 [CH. Param.])
- 2) For input, select “COMM”.
Settable items are input, chart recording lower-limit/higher-limit, unit, tag, display skip, digital printing skip, and memory card recording skip only. The cursor moves to the other items, but no setting can be done.
- 3) Change the setting of recording range.
Lower-limit “-3000.0”, higher-limit “3000.0” are already set in setting parameter input area of chart recording lower-limit/higher-limit. Change the setting value (include decimal point position) depending on the communication input value.
- 4) Unit, tag, and skip can be set in the same way as in normal input.

【Note 1】

Setting of data communication input is made form channel 1 to channel 36.

【Note 2】

If data communication input is not received, recording (analog/digital) is not performed even if setting of channel parameter is done.

8-4 Dot setting [DOT]

Tags and dot colors can be set every channel. Ten dot colors can be set optionally every channel.

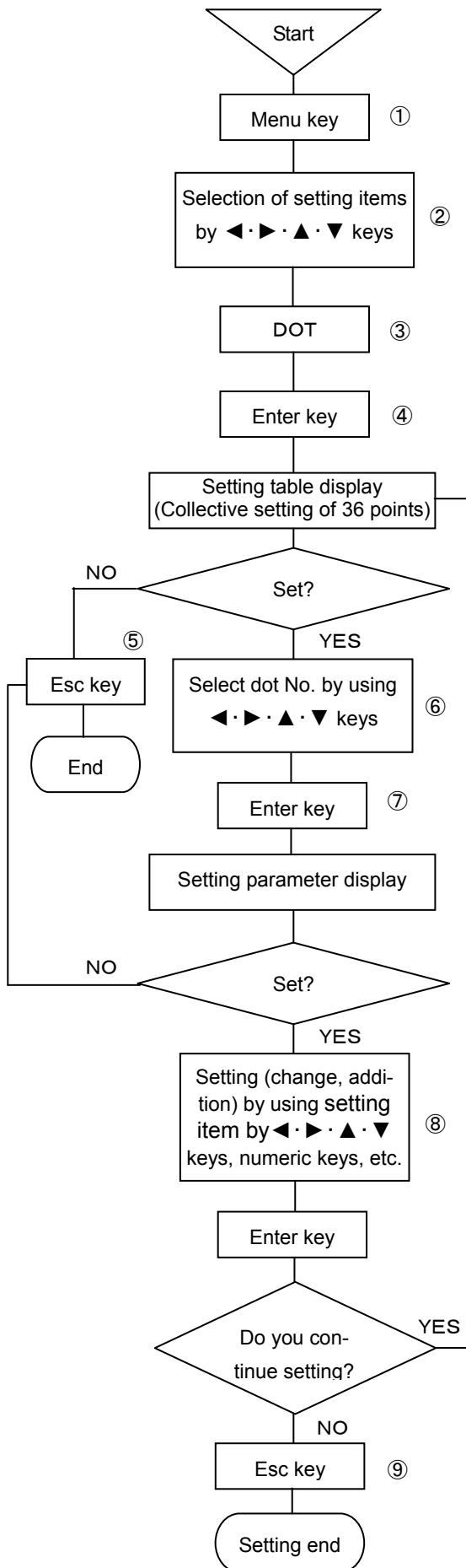

- ① Select the setting display mode by pressing Menu key. A window opens to display a setting items table.
- ② Move the cursor by ◀·▶·▲·▼ keys and select an item to be confirmed.
- ③ Select DOT.
- ④ Press Enter key to enter the setting table display (collective 36 points) screen. [For the setting table display (collective 36 points) screen, refer to ⑥.]
- ⑤ For stopping the setting, the screen returns to the last one, each time Esc key is pressed once.
- ⑥ Move the cursor to a desired dot number to be set by ◀·▶·▲·▼ keys. The cursor does not move to any item other than dot No.

RECORD ON					100mm/h					2005/06/14 16:47:36				
Dot No.	Inp. CH.	Tag	Col.	Rec.	Dot No.	Inp. CH.	Tag	Col.	Rec.	Dot No.	Inp. CH.	Tag	Col.	Rec.
01	001	*001	G	ON	13	013	*013	Or	ON	25	025	*025	RP	ON
02	002	*002	YG	ON	14	014	*014	R	ON	26	026	*026	Br	ON
03	003	*003	Or	ON	15	015	*015	RP	ON	27	027	*027	BG	ON
04	004	*004	R	ON	16	016	*016	Br	ON	28	028	*028	BP	ON
05	005	*005	RP	ON	17	017	*017	BG	ON	29	029	*029	P	ON
06	006	*006	Br	ON	18	018	*018	P	ON	30	030	*030	Bl	ON
07	007	*007	BG	ON	19	019	*019	BP	ON	31	031	*031	G	ON
08	008	*008	P	ON	20	020	*020	Bl	ON	32	032	*032	YG	ON
09	009	*009	BP	ON	21	021	*021	G	ON	33	033	*033	Or	ON
10	010	*010	Bl	ON	22	022	*022	YG	ON	34	034	*034	R	ON
11	011	*011	G	ON	23	023	*023	Or	ON	35	035	*035	RP	ON
12	012	*012	YG	ON	24	024	*024	R	ON	36	036	*036	Br	ON

Esc : Close Enter : Dot set Func2 : Rec. ON/OFF CONST

- ⑦ Select a dot No. to be set and press Enter key. A window opens to display a setting parameter entry screen. (For the setting parameter entry screen, refer to ⑧.)
- ⑧ Move the cursor to a desired item to be set by ◀·▶·▲·▼ keys.

Dot set 1

Input CH. Tag

Color ▼

Record ▼

The cursor moves in the sequence of Input channel → Tag → Color → Record → Set, each time Enter key is pressed once. Use numeric keys for input channel or use numeric keys or other keys for tags, and input setting parameters to the parameter input area. For other parameter input area, select setting parameters. A window opens to be ready for selection by ▲·▼ keys. After the end of setting in this screen, bring the cursor to .

- ⑨ Terminate the setting (change, addition) by pressing Enter key. Press Esc key if the setting contents are not saved.

(Caution 1)

Default *001, *002 ... are input (displayed) in the tag area on screen ⑥. No tag default is displayed on setting parameter entry screen ⑧. If defined without setting as it is, printing, display, and all other items are set as default.

[Point]

Dot recording is turned on or off on setting parameter entry screen ⑧. However, it can also be done on setting table display screen ⑥. Bring the cursor to a desired dot No. to be set, and press Func2 key. Dot recording is turned on or off selectively, each time Func2 key is pressed once.

8-5 Chart recording setting [CHART]

Chart speed and dotting cycle can be set. An optional cycle to be set here becomes a dotting cycle. In this case, the dotting synchronization must be set to [Optional cycle].

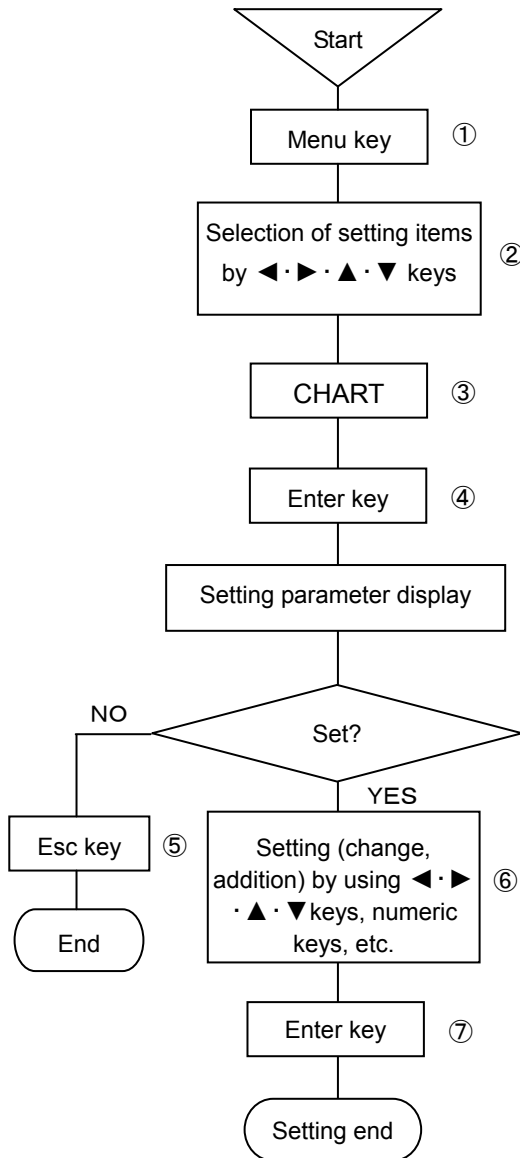

- ① Select the setting display mode by pressing Menu key. A window opens to display a setting items table.
- ② Move the cursor by ◀ · ▶ · ▲ · ▼ keys and select an item to be confirmed.
- ③ Select CHART.
- ④ Press Enter key to enter a desired parameter setting mode to be set. A window opens to display a setting parameter entry screen. (For the setting parameter entry screen, refer to ⑥)
- ⑤ For terminating the setting, the screen returns to the last one, each time Esc key is pressed once.
- ⑥ Move the cursor to a desired item to be set by ◀ · ▶ · ▲ · ▼ keys.

Chart rec. set	
Chart Speed	<input type="text"/> mm/hour
Dot sync.	<input type="text" value="Chart speed"/> ▼
Set cycle	<input type="text"/> Sec
<input type="button" value="Set"/>	

The cursor moves in the sequence of chart speed → Dot synchronization → Set cycle → Set, each time Enter key is pressed once.

1. Input a setting parameter to the chart speed parameter input area by using numeric keys.
For this setting, set the chart speed to an optional value in units of 1mm/h within a range of 1mm/ to 1500mm/h.
2. The dotting synchronization parameter input area adopts the setting parameter selection system. Open the window and select a setting parameter by ▲ · ▼ keys.
For selecting the dotting synchronization, refer to the following table.
3. For an optional cycle parameter input area, input a setting parameter by numeric keys.
Set it to an optional speed in units of 1s within a range of 1s – 60s. However, this setting becomes ineffective if the dotting synchronization is set to [Chart speed].
4. After setting this screen, bring the cursor to .
- ⑦ Terminate the setting (change, addition) by pressing Enter key.

Dot synchronization

<input type="text" value="Chart speed"/>
<input type="text" value="Set cycle"/>

For this setting, observe the following cautions.

(Caution 1) Dotting synchronization (dotting cycle)

The [Chart speed] is dotted as analog recording every 0.2mm in the vertical (time axis) direction at all times. Since the printer dots data at a ratio of about 1 line/3 seconds, analog recording is intermittent, if recording is done at a chart speed of higher than 240mm/h [Optional cycle] means the dotting at a preset dotting cycle, and it is used when the input changes abruptly. If the input changes slowly and the chart speed is low, the chart may be broken.

(Caution 2) Dotting synchronization (dotting cycle)

When the dotting cycle is set optionally, the latest data at the dotting time are recorded. A trouble may occur if the dotting cycle is set to a high chart speed under its optional setting condition. The following troubles occur if the dotting cycle or optional cycle is longer than an interlocking value of the chart speed.

[Chart speed] In case of interlocking dotting of chart speed

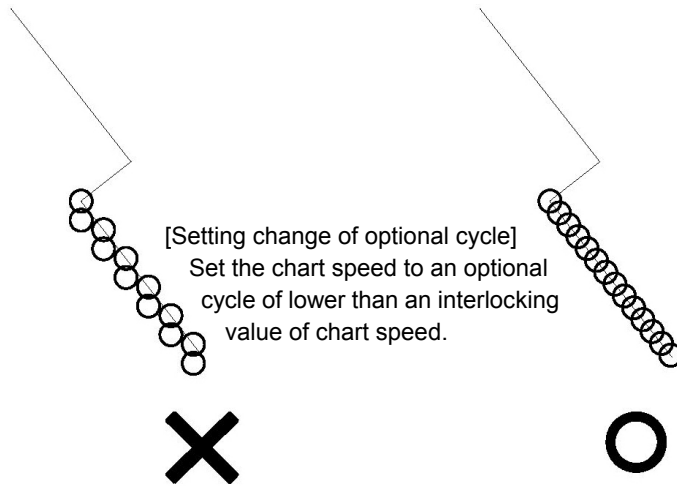

[Optional cycle] In case of interlocking dotting at an optional cycle

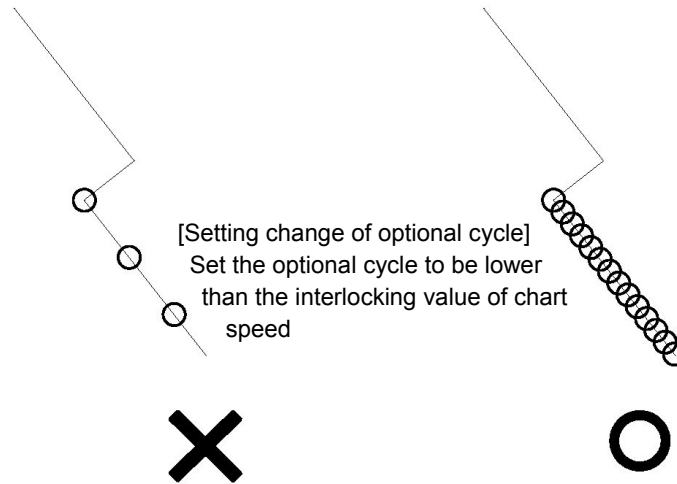

(Caution 3) Dotting cycle

The analog dotting cycle of this unit is basically set to dot once every 0.2mm in the time axis direction. The chart speed interlocking value is calculated by the following formula.

$$\text{Dotting cycle [sec]} = 3,600\text{sec} \times \frac{0.2 \text{ [mm]}}{\text{Chart speed [mm/h]}}$$

Accordingly, the latest data are dotted by setting the optional cycle to be shorter than the interlocking value of chart speed.

(Caution 4) Optional cycle

When [Dotting cycle] is set to an optional cycle, dotting is synchronized with the preset optional cycle. The dotting speed of one line may become 3s as the longest time (when zero side dotting ⇔ span side dotting are repeated alternately, for example). If the optional cycle is set to 1s under the above circumstance, the dotting is done at the highest speed to follow the cycle.

8-6 Alarm setting [ALARM]

Alarm setting means the setting of a higher-limit or lower-limit alarm point at an optional point in the analog recording range. Number of alarm points can optionally be set up to 4 points per channel, and the kinds of alarms (higher-limit alarm or lower-limit alarm) can be set optionally.

※) Alarm outputs are prepared up to 36 points max. per unit as option measures.

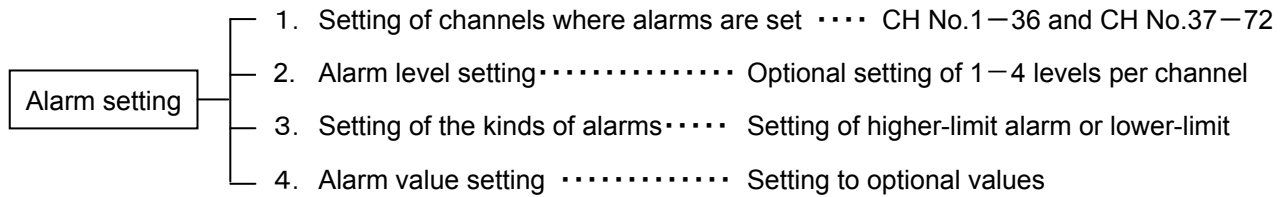

1. Display and printing of the occurrence and cancellation of alarms

When an alarm occurs, [ALARM] and [CH No.] where an alarm occurred light in the display section. [CH No.] is displayed by sequentially switching all generated [CH No.]. [Tag], [Kinds of alarms], [Alarm level], and [Alarm occurrence time] of the channel where an alarm occurred are printed at the right end of the chart, while [Tag], [Alarm level], and [Alarm cancellation time] are printed when the alarm was canceled.

For analog recording in a channel where an alarm occurred, generation mark __, red under score/cancellation mark __, and green under score are marked.

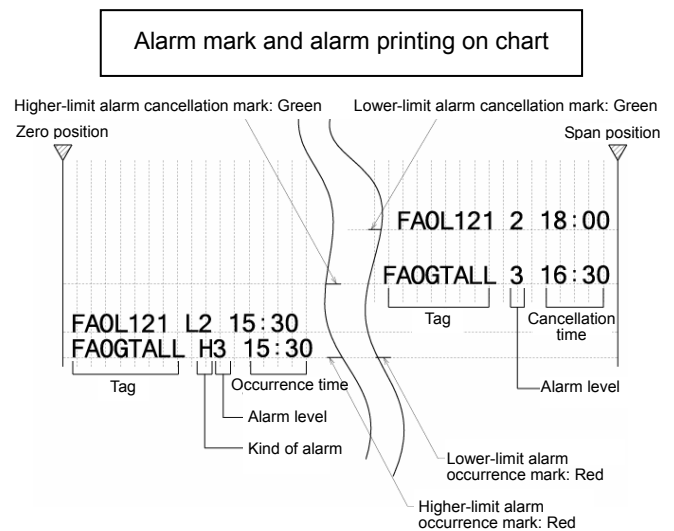
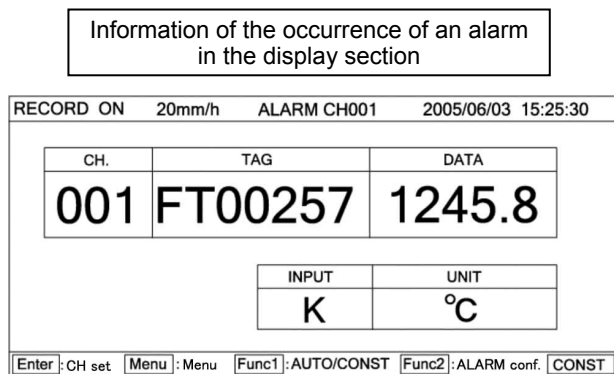

When an alarm occurs, [ALARM CH001] lights, and displayed data turn red. When the alarm is cancelled, the display color returns as before.

(Caution 1)

Alarm occurrence and cancellation printing is related with the chart speed. Be careful with the following items.

- ① When the chart speed is lower than 200mm/H, an alarm occurrence is printed red, and an alarm cancellation is printed green. When the chart speed is higher than 200mm/H, an alarm is printed black, except for the occurrence and cancellation marks.
- ② When the alarm occurrence or cancellation is printed, a printing space is secured for avoiding overlapped printing, so that the following printing is not done.

(Caution 2)

Max. 120 occurred and cancelled alarms can be stored into memory. Alarm occurrence and cancellation printing newly occurred during this period is not accumulated.

2. No. of setting alarm points

One to four alarm points per channel can be set to optional points in the alarm recording range.

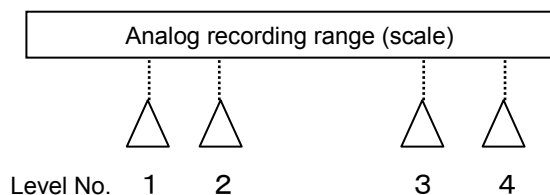

3. Kinds of alarms

Higher-limit alarm (H) and lower-limit alarm (L) can optionally be set every channel.

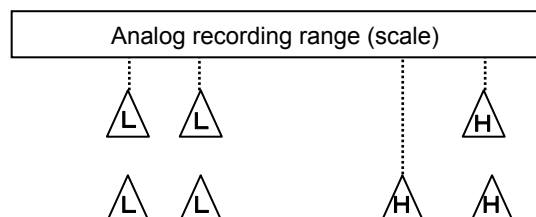

4. Alarm setting

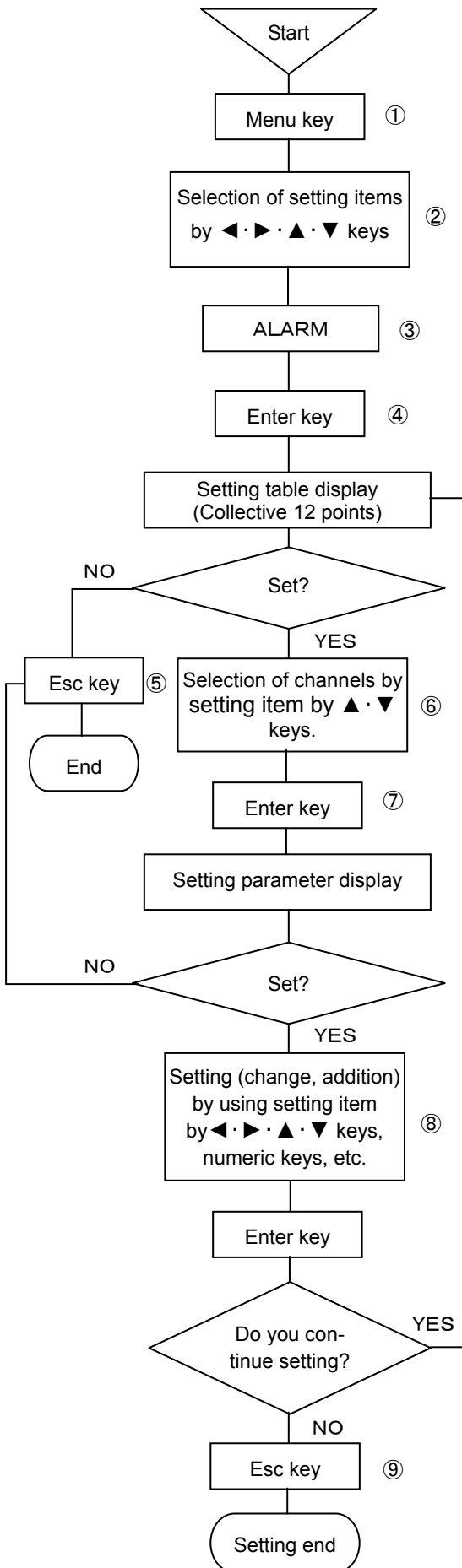

- ① Select the setting display mode by pressing Menu key.
A window opens to display a setting items table.
- ② Move the cursor by ◀ · ▶ · ▲ · ▼ keys and select an item to be set.
- ③ Select ALARM.
- ④ Enter the setting table display (collective 12 points) screen by pressing Enter key. (For the setting table display (collective 12 points) screen, refer to ⑥.)
- ⑤ For stopping the setting, the screen returns to the last once, each time Esc key is pressed once.
- ⑥ Move the cursor to a desired channel number to be set by ▲ · ▼ keys.
The cursor does not remove to any item other than CH No.

RECORD ON 20mm/h ALARM CH001 2005/06/03 15:25:30											
CH.	1st level					2nd level					
	Kind	Relay	Mode	Set value	Dead band	Kind	Relay	Mode	Set value	Dead band	
001											
002											
003											
004											
005											
006											
007											
008											
009											
010											
011											
012											

Esc : Close Enter : ALARM set Func1 : Next Func2 : Copy CONST

- ⑦ Select a channel to be set and press Enter key.
A window opens to display the setting parameter entry screen. (For the setting parameter entry screen, refer to ⑧.)
- ⑧ Move the cursor to a desired item to be set by setting item by ◀ · ▶ · ▲ · ▼ keys.

Alarm CH001

Level ▼

Kind ▼

Relay No. And/Or ▼

Set value Dead band

- The cursor moves in the sequence of Level → Kind → Relay No. → And/Or → Set value → Dead band → Set.
- The parameter input area for level, kind, and output connections adopts the setting parameter selection system. A windows opens to be ready for selection by using ▲ · ▼ keys. For output relay No., set values, and dead band, input setting parameters by using numeric keys.
- After setting has been terminated on this screen, bring the cursor to .
- ⑨ Terminate the setting (change, addition) by pressing Enter key. Press Esc key if the setting contents are not saved.

(Caution1)

If an alarm output and contact output option are not added, the cursor does not move to [Relay output No.]/[Output connections] parameter input area.

(Caution2)

Alarm set value and dead band relate to decimal point position of scale set value of setting channel. When decimal point position of scale set value is in the second place, set the second place of decimal point of alarm set value and dead band. Set the dead band by absolute value.

- ⑩ By pressing Func1 in the screen display in ⑥ above, the following screen is displayed. Screens ⑥, ⑩ are used for confirming the setting and copying the setting items in the setting screen to the other channels.

RECORD ON 20mm/h ALARM CH001 2005/06/03 15:25:30										
CH.	3rd level					4th level				
	Kind	Relay	Mode	Set value	Dead band	Kind	Relay	Mode	Set value	Dead band
001										
002										
003										
004										
005										
006										
007										
008										
009										
010										
011										
012										

Esc :Close Enter :ALARM set Func1 :Previous Func2 :Copy CONST

For returning to screen ⑥ from screen ⑩, press Func1 key again.

Screen ⑧ can also be displayed by pressing Enter key after moving the cursor to a desired channel number to be set by ▲ · ▼ keys in this screen.

- ⑪ For copying channel parameters to the other channel, press Func2 key in either screen ⑥ or ⑩.
- ⑫ Move the cursor to a desired item to be copied by setting item by ◀ · ▶ · ▲ · ▼ keys.

Copy

Level 1 Level 2 Level 3 Level 4

Source Dest. ~

Each time Enter key is pressed once, [L]/[] is repeated.

Select [L] for a desired setting item to be copied, and select [] for a setting item to be not copied. Press Enter key after moving the cursor to the copy source.

After inputting a desired channel number as the copy source by numeric keys, press Enter key, and the cursor moves to the copy destination.

By pressing Enter key furthermore, the channel number at the copy destination can be input by numeric keys. By pressing Enter key after inputting a channel number at the copy destination, the cursor moves to [~]. Press Enter key, and the channel number at the copy destination can be input by numeric keys.

After the end of setting on this screen, bring the cursor to .

- ⑬ Terminate the copy by pressing Enter key.

[Point]

Each level when setting and copying an alarm includes the kind of alarm and a set value (an alarm value) being set to the level.

5. Alarm check

Whether an alarm occurred or not can be recognized in normal data display screen. The kinds of alarms, level, etc. can be confirmed by the following method.

- ⑭ Press Func2 key in normal data display screen.

RECORD ON 20mm/h ALARM CH001 2005/06/03 15:25:30		
CH.	TAG	DATA
001	FT00257	1245.8
INPUT		UNIT
K		°C

Enter :Ch.set Menu :Menu Func1 :AUTO/CONST Func2 :ALARM conf. CONST

- ⑮ Select a desired channel number to be confirmed by setting item by ◀ · ▶ · ▲ · ▼ keys. The cursor does not move to any position other than channel numbers.

RECORD ON 20mm/h 2005/06/03 15:25:30												
Alarm CH	DATA	Level				Alarm CH	DATA	Level				
		1	2	3	4			1	2	3	4	
001	1250.3	L	L	H	H	007	1250.3	L	L	H	H	
002	110.5		L	H		008	110.5		L	H		
003	125.8		H	H	H	009	125.8		H	H	H	
004	1000.3	L	L	H	H	010	1000.3	L	L	H	H	
005	10.005	L	L	L		011	10.005	L	L	L		
006	180.35	L	L	H	H	012	180.35	L	L	H	H	

H: Higher, L: Lower 2005/06/03 15:30:30

Esc :Close Enter :ALARM set. Func1 :Renewal CONST

This alarm confirmation screen is displayed by pressing Func2 key on screen ⑭, and it is fixed at the time the Function 2 key was pressed.

The time displayed at the lower right part of the screen shows the pressed time of Func2 key. For confirming the time after updating it, press Func1 key. The alarm at the pressed time of Func1 key can be confirmed.

For resetting to normal data display screen, press Esc key. Also, alarm setting can be changed from this screen.

Move the cursor to a desired channel number to be changed, and press Enter key. Screen ⑧ on the last page is displayed to be ready for setting according to the same procedure.

8-7 Differential recording setting [CALC.]

Differential recording comprises 2 methods. One records a difference between ①A channel data and B channel data in channel C, while the other records a difference between ②D channel data and a reference value in channel E. (This function is provided in LE5100 only. In case of LE5200, this function is executed by the mathematical configuration.)

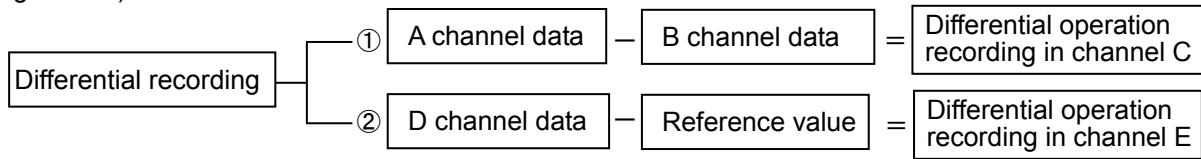

1. CH No. setting

Designate channel A, B or D optionally from CH No. 1 – 36 and also designate channel C or E in differential operation recording optionally from CH No. 37 – 72.

2. Analog recording range setting

Set a range without fail before starting differential recording. (See Caution 4)

For channel C or E to be differential recorded, record a [Difference value] as data. For this purpose, set the analog recording range by the lower-limit and higher-limit of chart recording. Set a unit, as occasion demands. For the analog recording range, estimate a [Difference value] in advance before setting it.

An example of differential recording between 2 channels

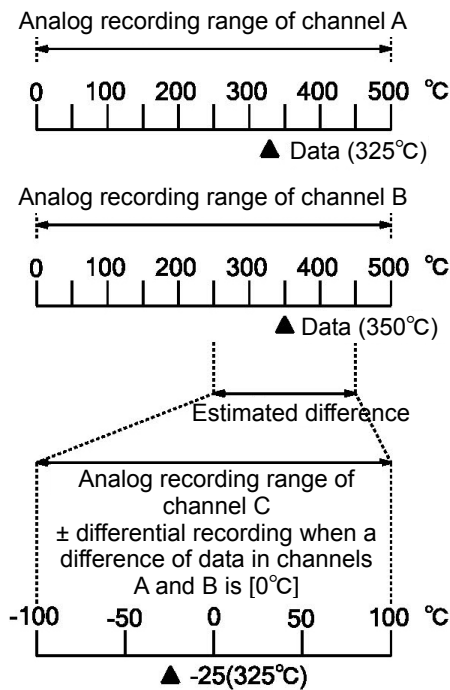

An example of differential recording between 2 channels

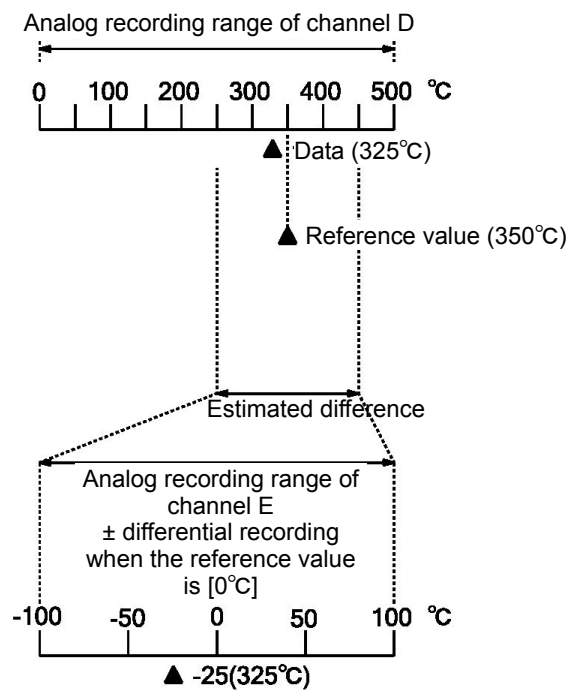

(Caution 1) Use CH No. 37 – 72 as differential operation recording channels.

(Caution 2) Carry out differential operation by neglecting the unit.

(Caution 3) The analog recording range of the differential operation recording channel is set by setting channel parameters. For setting the channel parameters for operation output channels, refer to the next page. Error contents are displayed if normal range setting is done.

(Caution 4) Differential operation of an input channel where a scale is set by DC voltage input is carried out by a scaling value (actual scale value).

Setting of channel parameters for operation output channel

Refer to 8-3 Channel parameter setting, designate an output channel out of channels in and after CH037. Select a channel in and after CH037 and press Enter key. The following window opens to display the setting parameter entry screen.

CH setting CH037					
Input	<input type="text"/>	RJ	Ext.	Burn	None
Filter	None				
Range MIN	<input type="text"/>	Range MAX	<input type="text"/>		
Scale MIN	<input type="text"/>	Scale MAX	<input type="text"/>	Corr.	<input type="text"/>
Unit	<input type="text"/>				
Record MIN	<input type="text"/>	Record MAX	<input type="text"/>	Tag	<input type="text"/>
Display skip	Off	Digital printing skip	Off		
Memory card rec. skip	Off				Set

In this setting parameter entry screen, settable items are input, unit, lower-limit of chart recording, higher-limit of chart recording, tag, display skip, digital printing skip, and memory card recording skip only. The cursor can move to other items, but setting cannot be done. Select input setting parameters in and after CH037 from 2 kinds consisting of [Not used] and [Operation]. Select [Operation] when a channel is used as an operation output channel.

Copy of channel parameters for operation output channel

Set this item in the same way as in 8-3 Channel parameter setting.

Setting copy							
<input checked="" type="checkbox"/>	Input, RJ, Range, Scale, Burn	<input checked="" type="checkbox"/>	Unit	<input type="checkbox"/>	Corr.	<input checked="" type="checkbox"/>	Filter
<input type="checkbox"/>	Tag	<input type="checkbox"/>	Record range				
<input type="checkbox"/>	Display skip	<input type="checkbox"/>	Digital rec. skip	<input type="checkbox"/>	Memory card skip		
<input type="checkbox"/>	Memory card rec. skip						
Copy source	1	Copy destination	<input type="text"/>	~	<input type="text"/>	Copy	

Press Func2 key in the channel parameter setting screen to display the above CH setting copy screen. The cursor moves to all items, but neither correction nor filter item can be set. Copy the set values by the equivalent operation.

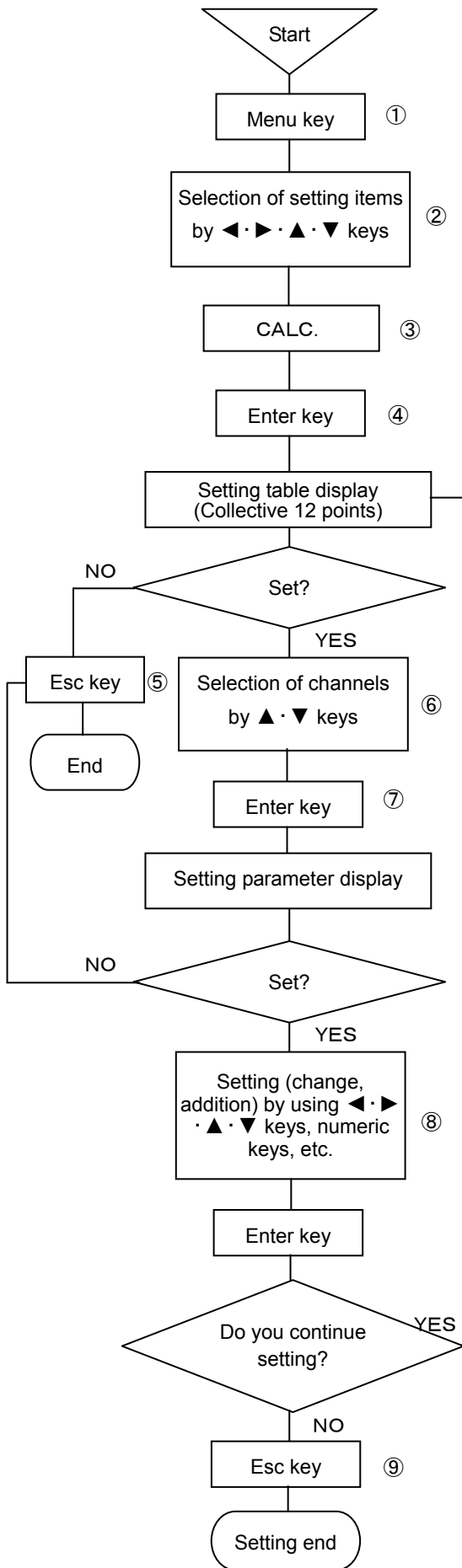

- ① Select the setting display mode by pressing Menu key. A window opens to display a setting items table.
- ② Move the cursor by $\leftarrow \rightarrow \cdot \uparrow \downarrow$ keys and select an item to be set.
- ③ Select CALC.
- ④ Enter the setting table display (collective 12 points) screen by pressing Enter key. (For the setting table display (collective 12 points) screen, refer to ⑥.)
- ⑤ For stopping the setting, the screen returns to the last once, each time Esc key is pressed once.
- ⑥ Move the cursor to a desired channel number to be set by $\uparrow \downarrow$ keys. The cursor does not remove to any item other than CH No.

RECORD ON		100mm/h			2005/06/14 10:33:28	
CH.No.	Kind	Sub/Sui			Result D.P.	
		Ch.	Ch.	Const.C		
CH037						
CH038						
CH039						
CH040						
CH041						
CH042						
CH043						
CH044						
CH045						
CH046						
CH047						
CH048						

ESC : Close Enter : Operation Func2 : Copy AUTO

- ⑦ Select a channel to be set and press Enter key. A window opens to display the setting parameter entry screen. (For the setting parameter entry screen, refer to ⑧.)
- ⑧ Move the cursor to a desired item to be set by $\leftarrow \rightarrow \cdot \uparrow \downarrow$ keys.

Calculation CH037

Kind ▼

X CH. Y CH.

Const. C

Decimal point

The cursor moves in the sequence of Kind → X CH → Y CH → Reference value C → No. of decimal digits after operation → Set.

The parameter input area for kind adopts the setting parameter selection system. A windows opens to be ready for selection by using $\uparrow \downarrow$ keys. For other items, input setting parameters by using numeric keys. After setting has been terminated on this screen, bring the cursor to . Select the parameter input area for kind from the following items.

None	
SUB	Inter-CH differential recording: X-Y
SUI	Reference value differential recording: X-C

When SUB is selected, setting of reference value C is invalid.
When SUI is selected, setting of Y CH is invalid.

- ⑨ Terminate setting (change, addition) by pressing Enter key. Press Esc key if the setting contents are not saved.
- ⑩ For copying the operation setting, press Func2 key in screen ⑥.
- ⑪ Move the cursor by $\leftarrow \rightarrow \cdot \uparrow \downarrow$ keys, and set the copy source and copy destination by numeric keys.

Copy

source DEST. ~

After the copy source and copy destination has been set, bring the cursor to , and terminate copy by pressing Enter key.

8-8 Message printing setting [MESSAGE]

A simple message can be printed. Max. 75 characters can be set when a channel is designated or max. 80 characters can be designated when no channel is designated; provided that these characters are restricted to those on the keyboard.

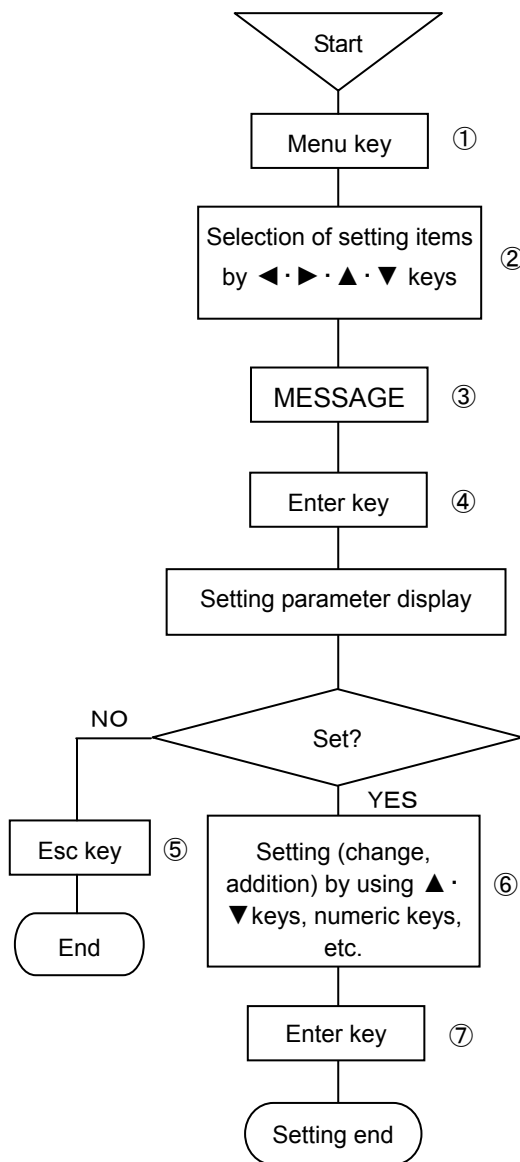

- ① Select the setting display mode by pressing Menu key.
A window opens to display a setting items table.
- ② Move the cursor by ◀ · ▶ · ▲ · ▼ keys and select an item to be set.
- ③ Select MESSAGE.
- ④ Press Enter key to enter the parameter entry mode of a desired item to be set.
A window opens to display the setting parameter entry screen.
(For the setting parameter entry screen, refer to ⑥.)
- ⑤ For stopping the setting, the screen returns to the last once, each time Esc key is pressed once.
- ⑥ Move the cursor to a desired item to be set by ▲ · ▼ keys.

Message

Ch.

Message

The cursor moves in the sequence of Input CH → Message → Printing, each time. Enter key is pressed once.
Input an optional channel number to the input CH parameter input area by numeric keys.
Input parameters directly into the message parameter input area by the keys on the keyboard. Scroll the parameter input area laterally according to the number of inputs.
After the end of setting in this screen, bring the cursor to .

- ⑦ Press Enter key to terminal setting (change, addition) and print a message.

A message printing example

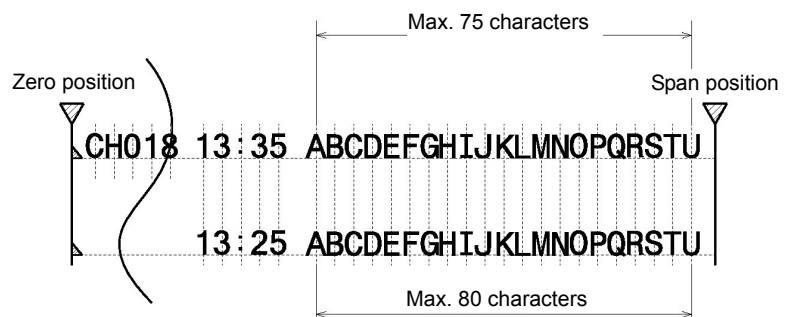

(Caution 1)

If no channel is designated, keep input CH parameter input area blank.

(Caution 2)

When a channel is designated, max. 75 characters can be set.
When no channel is designated, max. 80 characters can be set.

(Caution 3)

Inputable characters are limited to the characters being arranged on the keyboard.

8-9 List printing setting [LIST PRINT]

This function is used for confirming the setting contents. List printing comprises all setting items list printing to print all setting items being set at present and designated items list printing to print designated setting items only.



- ① Select the setting display mode by pressing Menu key. A window opens to display a setting items table.
- ② Move the cursor by ◀ · ▶ · ▲ · ▼ keys and select an item to be set.
- ③ Select LIST PRINT.
- ④ Press Enter key to enter the parameter entry mode of a desired item to be set. A window opens to display the setting parameter entry screen. (For the setting parameter entry screen, refer to ⑥.)
- ⑤ For stopping the setting, the screen returns to the last once, each time Esc key is pressed once.
- ⑥ Move the cursor to a desired item to be set by ▲ · ▼ keys.

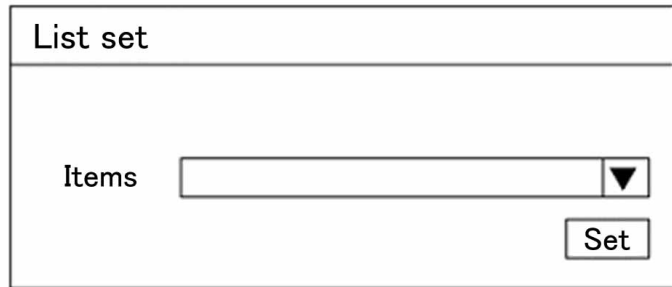

The cursor moves to Printing item → Printing, each time Enter key is pressed once.

The parameter input area of printing items adopts the setting parameter selection system.

A window opens to be ready for selection by using ▲ · ▼ keys. For each printing item, refer to the following table.

After the end of the setting in this screen, bring the cursor to **Set**.

- ⑦ Press Enter key to terminate the setting (change, addition).

Printing items

Items
All
Recording range
Analog dot
Range
Digital print
Chart speed

[Recording range] is setting of selected recording format.
 [Range] includes the scale, tag, unit, etc.

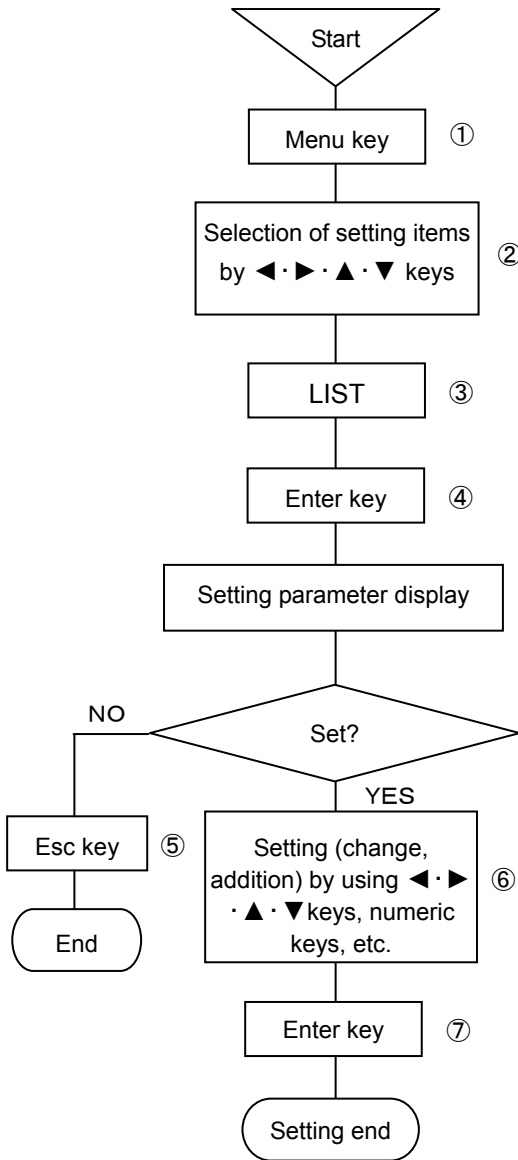

(Caution 1)

For interrupting the list printing halfway, turn off the recording once, and then, reset to the recording ON condition.

List printing is interrupted at the end of printing of the line being printed at that time. When the list printing was interrupted, it cannot be continued (reopened) any more. Start the list printing from the beginning.

(Caution 2)

No setting change can be done during list printing, but the setting can be confirmed.

8-10 Data interval recording setting [DATA INT.]

This unit digitally records measuring data of all channels at a desired time and a desired interval time.

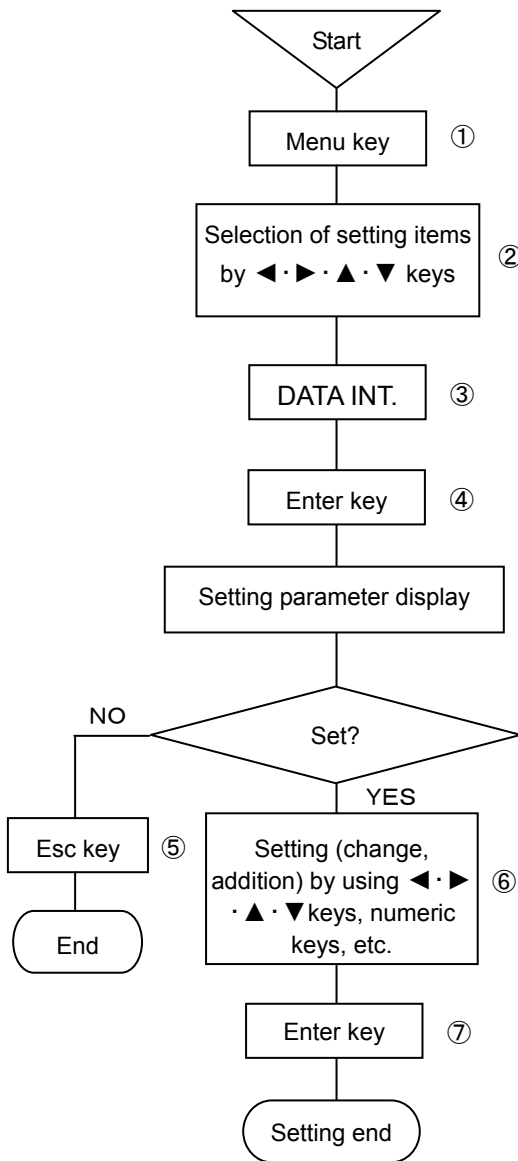
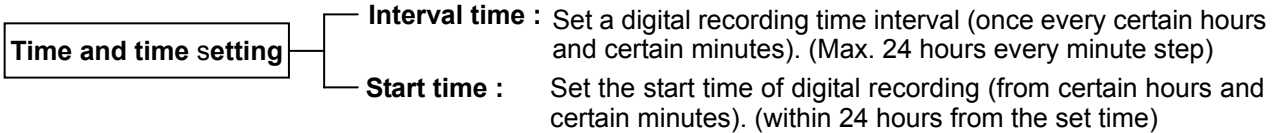

- ① Select the setting display mode by pressing Menu key. A window opens to display a setting items table.
- ② Move the cursor by ◀·▶·▲·▼ keys and select an item to be set.
- ③ Select DATA INT.
- ④ Enter the parameter entry mode of a desired item to be set by pressing Enter key. A window opens to display the setting parameter entry screen. (For the setting parameter entry screen, refer to ⑥.)
- ⑤ For stopping the setting, the screen returns to the last once, each time Esc key is pressed once.
- ⑥ The cursor moves to a desired item to be set by ◀·▶·▲·▼ keys.

Data Int. set

Format ▼

Interval
Hour Min.

Start
Hour Min. Set

- The cursor moves to Format → Recording interval (hours) → Recording interval (minutes) → Start time (hours) → Start time (minutes) → Set, each time Enter key is pressed once. The format parameter input area adopts the setting parameter selection system. A window opens to be ready for selection by ▲·▼ keys. For the recording interval (hours), recording interval (minutes), start time (hours) and, start time (minutes), input setting parameters by numeric keys. For selecting formats, refer to the following table. After the end of setting in this screen, bring the cursor to **Set**.
- ⑦ Terminate the setting (change, addition) by pressing Enter key.

Format

None	
TAG+DATA[1CH/line]	①
TAG+DATA+UNIT[6CH/line]	②
TAG+DATA+UNIT[10CH/line]	③

For printing examples of formats ②, ③, refer to 8-12 Data print recording setting [Printing example by format].

(Caution 1)

For setting the data interval, the shortest interval depends upon the chart speed, number of digital recording channels, and kinds of formats. When an impossible printing interval is set for chart speed, the interval is printed the smallest integer times.

Calculation formula for the shortest interval

$$\text{Shortest interval [H]} = \frac{4 \text{ mm} \times \text{No. of lines}}{\text{Chart speed [mm/h]}}$$

Format ①: No. of lines = No. of channels + 2 lines

Format ②: Minimum No. of lines 2 lines, 6 channels/line

Format ③: Minimum No. of lines 2 lines, 10 channels/line

A printing example by format

- ① Format 1: Applies to data interval printing
Reference position of sprocket Zero position

003	568
002	860
001	1013.5
	50MM/H
4.21	15:30

3-digit Tag No. (channel number) and 6-digit data are printed, and one-channel data are printed in one line. Each line is justified to the head if a channel is skipped.

[Point]

If the format is set to [None], digital printing is not started even at the specified time.

8-11 Logging recording setting [LOGGING]

This unit digitally records measuring data of all channels at a desired time and a desired interval time. Analog recording is not done during logging recording.

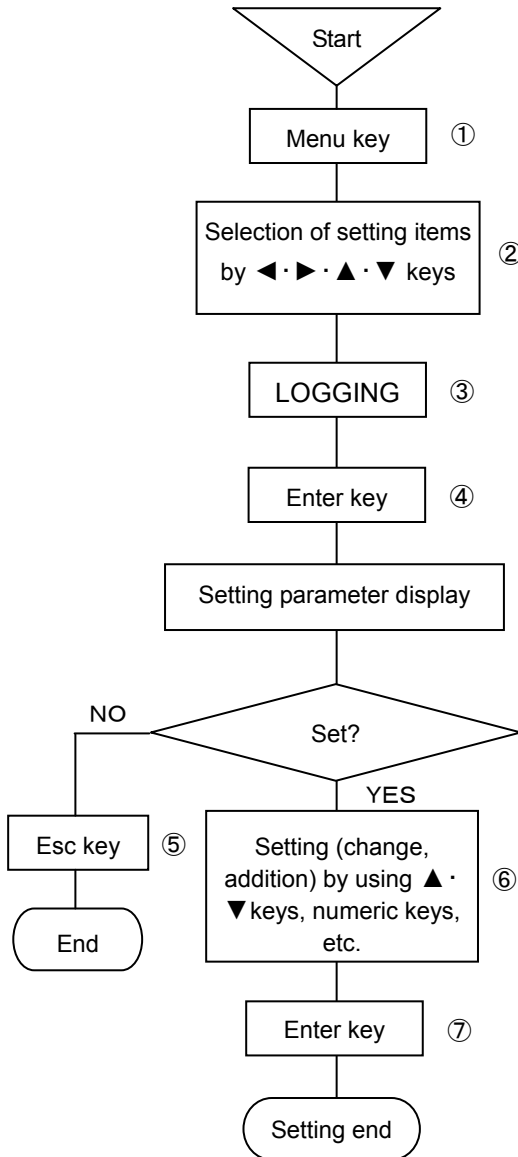
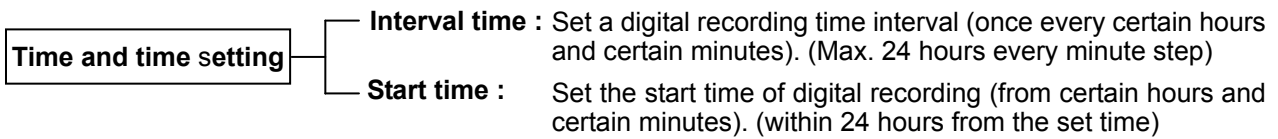

- ① Select the setting display mode by pressing Menu key. A window opens to display a setting items table.
- ② Move the cursor by ◀ · ▶ · ▲ · ▼ keys and select an item to be set.
- ③ Select LOGGING.
- ④ Enter the parameter entry mode of a desired item to be set by pressing Enter key. A window opens to display the setting parameter entry screen. (For the setting parameter entry screen, refer to ⑥.)
- ⑤ For stopping the setting, the screen returns to the last once, each time Esc key is pressed once.
- ⑥ The cursor moves to a desired item to be set by ◀ · ▶ · ▲ · ▼ keys.

The screenshot shows a window titled "Logging" with the following fields:

- Format: [Dropdown menu]
- Interval: Hour [] Min. []
- Start: Hour [] Min. []
- Set: [Set button]

The cursor moves to Format → Recording interval (hours) → Recording interval (minutes) → Start time (hours) → Start time (minutes) → Set, each time Enter key is pressed once. The format parameter input area adopts the setting parameter selection system. A window opens to be ready for selection by ▲ · ▼ keys. For the recording interval (hours), recording interval (minutes), start time (hours) and, start time (minutes), input setting parameters by numeric keys. For selecting formats, refer to the following table. After the end of setting in this screen, bring the cursor to **Set**.

- ⑦ Terminate the setting (change, addition) by pressing Enter key.

Format

None	
TAG+DATA+UNIT[6CH/line]	②
TAG+DATA+UNIT[10CH/line]	③

For printing examples of formats ②, ③, refer to 8-12 Data print recording setting [Printing example by format].

(Caution 1)

Analog recording is not done during logging recording. Accordingly, a set value of the chart speed being set at present becomes ineffective.

(Caution 2)

Logging recording formats are 2 kinds of ② and ③.

(Caution 3)

A LOGGING status is displayed in the display section during logging recording.

- ※) For canceling the logging recording, select format [None] in the above screen ⑥. Logging recording ends when Enter key is pressed and the setting ends. However, when printing is in progress, the logging recording ends after the demanded printing ends.

[Point]

When the format is set to [None], logging recording is not started at the specified time.

8-12 Data print recording setting [DATA PRINT]

Two kinds of data print formats are prepared. Set them according to uses.

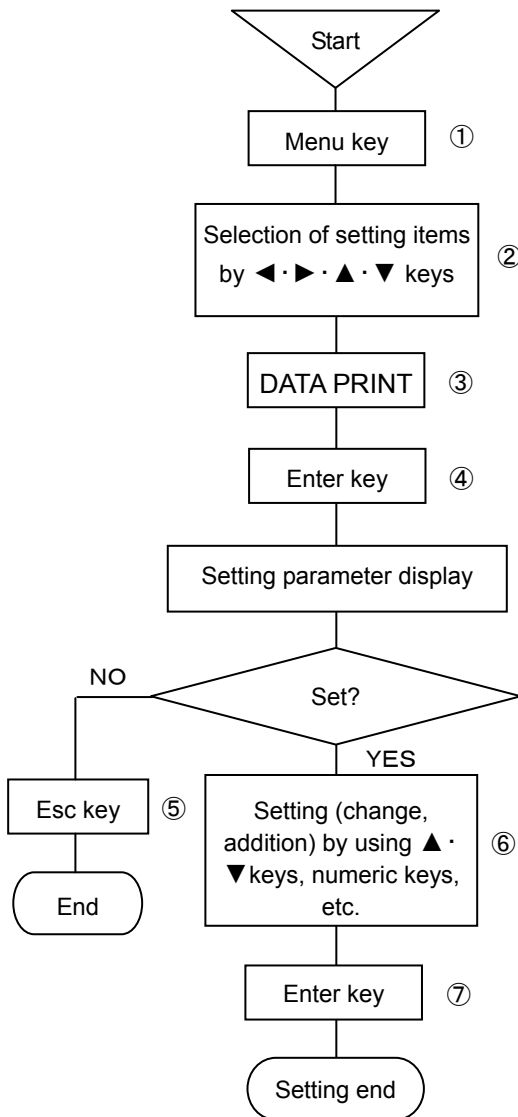

- ① Select the setting display mode by pressing Menu key.
A window opens to display a setting items table.
- ② Move the cursor by ◀·▶·▲·▼ keys and select an item to be set.
- ③ Select DATA PRINT.
- ④ Enter the parameter entry mode of a desired item to be set by pressing Enter key.
A window opens to display the setting parameter entry screen.
(For the setting parameter entry screen, refer to ⑥.)
- ⑤ For stopping the setting, the screen returns to the last once, each time Esc key is pressed once.
- ⑥ Press Enter key to move the cursor to the parameter input area.

Data print

Format ▼

Set

The cursor moves in the sequence of Format → Set, each time Enter key is pressed once. Select a format by ▲·▼ keys.

For selecting formats, refer to the following table.

After the end of setting in this screen, bring the cursor to

- ⑦ Terminate the setting (change, addition) by pressing Enter key.

Format

TAG+DATA+UNIT[6CH/line]	②
TAG+DATA+UNIT[10CH/line]	③

A printing example by format

- ② **Format 2:** Applicable to data printing, data interval, and logging recording

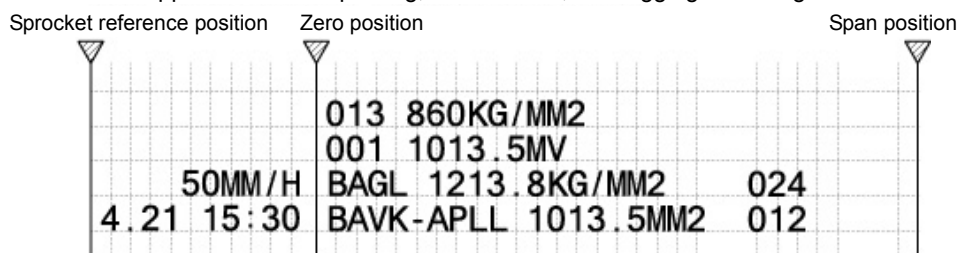

TAG No. Max.8 digits, Data Max.7 digits, Unit Max.7 digits (max. 19 digits) Data of 6 channels are printed in 1 line. If a channel is skipped, each line is justified to the

- ③ **Format 3:** Applicable to data printing, data interval, and logging recording

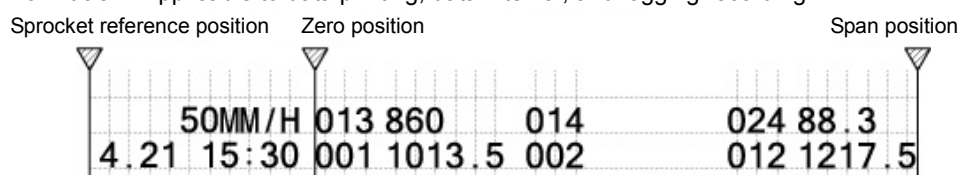

TAG No. (channel number) 3 digits, Data 6 digits printing Data of 10 channels are printed in 1 line. If a channel is skipped, each line is justified to the head.

8-13 Display setting [DISPLAY]

Kinds of display, update cycle, display brightness, and chart illumination setting can be done.

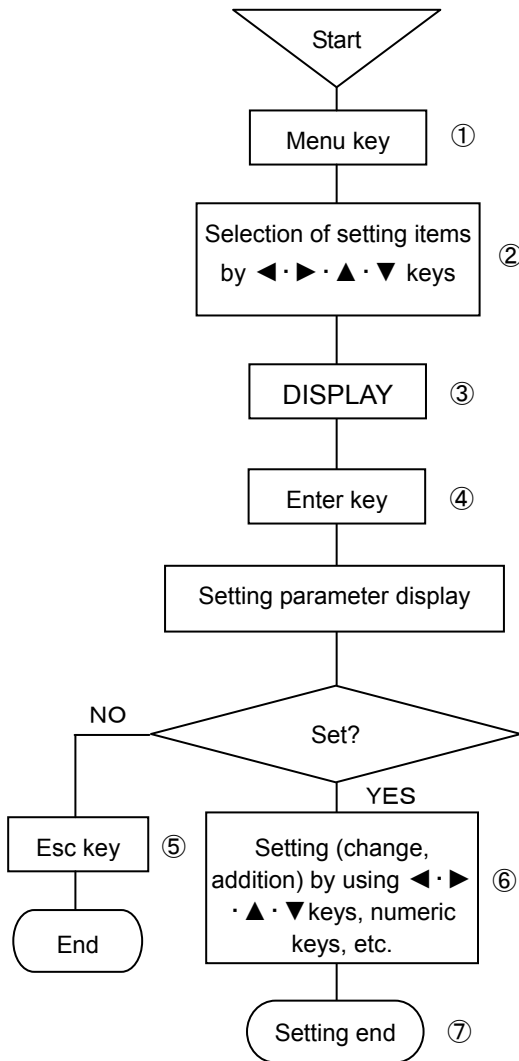

- ① Select the setting display mode by pressing Menu key.
A window opens to display a setting items table.
- ② Move the cursor by ◀·▶·▲·▼ keys and select an item to be set.
- ③ Select DISPLAY.
- ④ Enter the parameter entry mode of a desired item to be set by pressing Enter key.
A window opens to display the setting parameter entry screen.
(For the setting parameter entry screen, refer to ⑥.)
- ⑤ For stopping the setting, the screen returns to the last once, each time Esc key is pressed once.
- ⑥ The cursor moves to a desired item to be set by ◀·▶·▲·▼ keys.

Display set

Unit/Tag

Display interval

1Ch 12Ch 36Ch

Chart light Bright

Light timer Disp. timer

The cursor moves to Unit /Tag → CH update cycle 1CH → 12CH → 36CH → Chart light → Bright → Light timer → Disp. timer → Set, each time Enter key is pressed once.
All parameter input areas adopt the setting parameter selection system.
After the end of setting in this screen, bring the cursor to Set.

- ⑦ Terminate the setting (change, addition) by pressing Enter key.

(Caution 1)

The shortest channel update cycle of display is 1 second.

(Caution 2)

Recording chart illumination can be adjusted in 5 stages including OFF. Set the illumination at 1 to 4 levels during lighting.

(Caution 3)

Display brightness can be adjusted in 4 stages. Set the display brightness at 1 to 4 levels during lighting.

(Caution 4)

Illumination off timer and display off timer can be adjusted in 5 stages including none.
For operating the timer, select 1, 2, 3, 5, 10, or 30 minutes.
For lighting again, press [Esc] key.

Display mode

Tag	Channel number + range + measuring data + tag
Unit	Channel number + range + measuring data + unit

※) If 1CH display is set, the display mode becomes one kind of [Channel number + tag + measuring data + unit].

8-14 Engineering port setting [ENG.]

Various parameter settings in this instrument are changed and set by computer if [PASS], which is sold separately, is used. The computer and this instrument communicate by USB. In this case, setting USB address is necessary. Setting of USB recognition address is written below (setting of factory delivery is [1]). Engineering port (USB) is below the chassis front, so connect USB after opening the door (refer to 2-2. Front section of internal unit).

1. Address setting of this unit

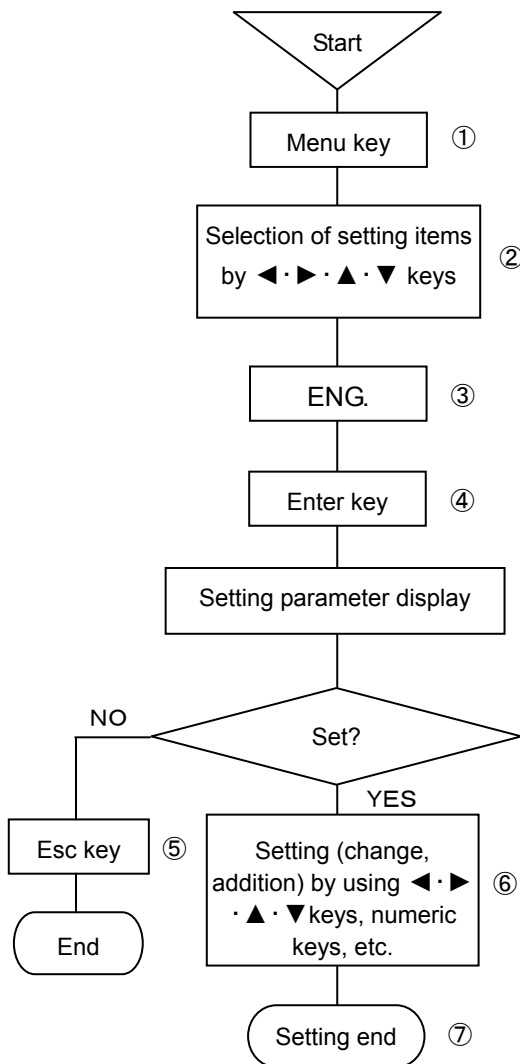

- ① Select the setting display mode by pressing Menu key.
A window opens to display a setting items table.
- ② Move the cursor by ◀·▶·▲·▼ keys and select an item to be set.
- ③ Select ENG.
- ④ Enter the parameter entry mode of a desired item to be set by pressing Enter key.
A window opens to display the setting parameter entry screen.
(For the setting parameter entry screen, refer to ⑥.)
- ⑤ For stopping the setting, the screen returns to the last once, each time Esc key is pressed once.
- ⑥ The cursor moves to a desired item to be set by ◀·▶·▲·▼ keys.

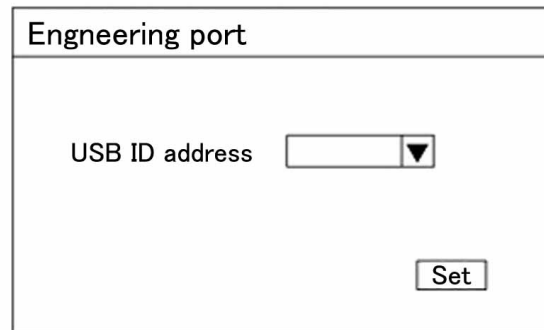

The cursor moves to USB identification address → Set, each time Enter key is pressed once.

This parameter input area adopts the setting parameter selection system.

Select an address out of 1 to 5.

After the end of setting in this screen, bring the cursor to **Set**.

- ⑦ Terminate the setting (change, addition) by pressing Enter key.

8-15 Date and time setting [DATE/TIME]

This unit is provided with a built-in clock for indicating year, month, day, hour, and minute. The present time is set at the delivery time from the factory. The clock can be set to an optional time as occasion demands.

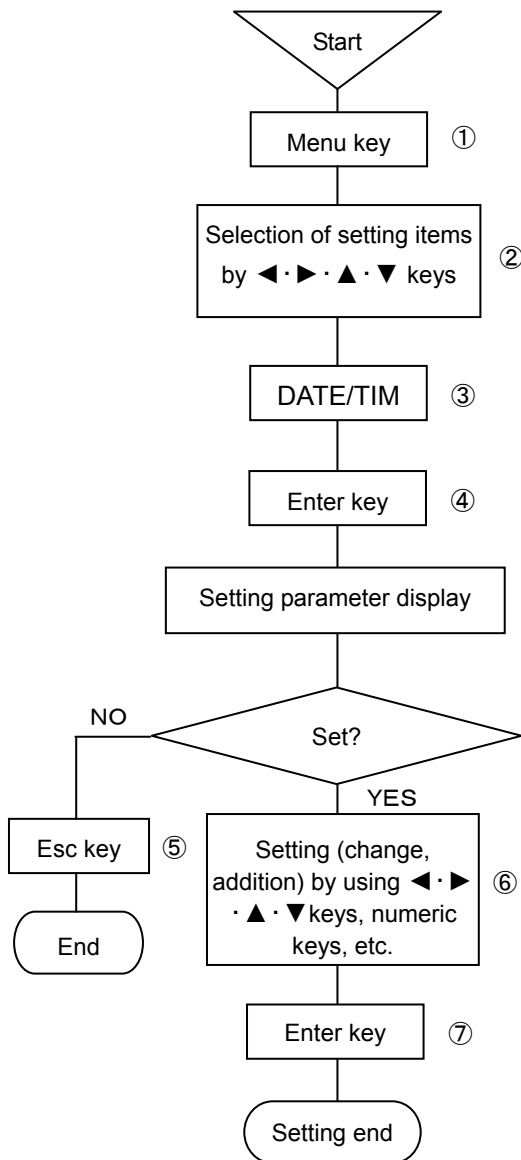

- ① Select the setting display mode by pressing Menu key.
A window opens to display a setting items table.
- ② Move the cursor by ◀·▶·▲·▼ keys and select an item to be set.
- ③ Select DATE/TIME.
- ④ Enter the parameter entry mode of a desired item to be set by pressing Enter key.
A window opens to display the setting parameter entry screen.
(For the setting parameter entry screen, refer to ⑥.)
- ⑤ For stopping the setting, the screen returns to the last once, each time Esc key is pressed once.
- ⑥ The cursor moves to a desired item to be set by ◀·▶·▲·▼ keys.

Data/Time		
Year	<input type="text"/>	Mon. <input type="text"/>
		Day <input type="text"/>
Hour	<input type="text"/>	Min. <input type="text"/>
		Sec. <input type="text"/>
<input type="button" value="Set"/>		

The cursor moves to AD → Month → Day → Hour → Minute → Second → Set, each time Enter key is pressed once.
Input setting parameters to the parameter input areas of all items by using numeric keys.
After the end of setting in this screen, bring the cursor to Set.

- ⑦ Terminate the setting (change, addition) by pressing Enter key.

(Caution 1)

Input 2-digit numeric values into the hour and minute parameter input area by using numeric keys.

Hour input : 00–23

Minute input : 00–59

(Caution 2)

Input AD by 4 digits.

8-16 System setting [SYSTEM 1]

This unit provides a setting function about setting inhibition and permission system. By inputting the password, the inhibition of setting change, memory clear (delivery condition from factory), dotting positions (zero, span), and input correction enable/disable conditions can be operated. Use this function as recovery processing when this unit does not function normally due to wrong operation, etc.

※) The password of this unit is [3571].

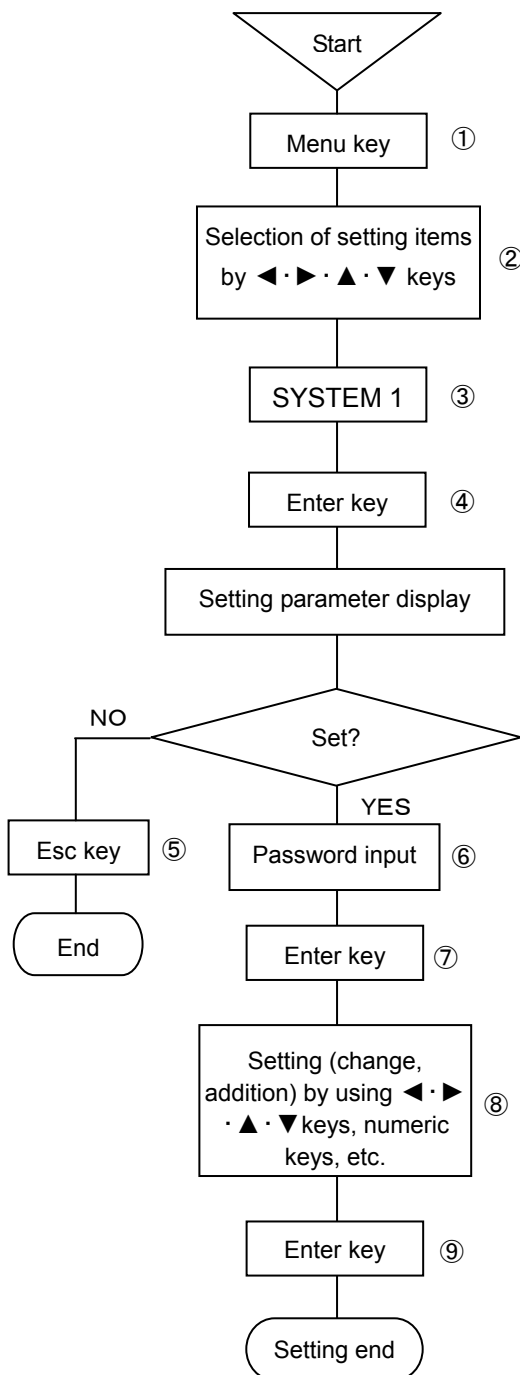

- ① Select the setting display mode by pressing Menu key.
A window opens to display a setting items table.
- ② Move the cursor by ◀·▶·▲·▼ keys and select an item to be set.
- ③ Select SYSTEM 1.
- ④ Enter the parameter entry mode of a desired item to be set by pressing Enter key.
A window opens to display the setting parameter entry screen.
(For the setting parameter entry screen, refer to ⑥.)
- ⑤ For stopping the setting, the screen returns to the last once, each time Esc key is pressed once.
- ⑥ The cursor moves to a desired item to be set by ◀·▶·▲·▼ keys.

System1 set

Password

Keylock

Memory Clear

Adjust of dotting position.

Input correction

Press Enter key, and input the 4-digit numeric value to the password input area.

- ⑦ Press Enter key to enable the setting change inhibition and permission.
- ⑧ Move the cursor to a desired item to be set by ▲·▼ keys.
After the cursor has moved, press Enter key and input [L] to permit the setting.
After the end of setting in this screen, bring the cursor to .
- ⑨ Terminate the setting (change, addition) by pressing Enter key.

(Caution 1)

Password is set to [3571] at the delivery time from the factory.

(Caution 2)

The password cannot be changed from the password at the delivery time from the factory.

(Caution 3)

When a setting change by keys was inhibited, none of all keys is accepted. [KEY LOCK] lights when various parameters are set.

(Caution 4)

Memory clear function returns the setting parameter information to the condition at the delivery time from factory.
Adjustment (zero and span calibration) data cannot be initialized by this operation.

8-17 PC card (memory card) setting [PC CARD]

8-17-1 Summary

Measuring data recorded by this unit can be stored into a PC card at an optional start time and a designated interval (highest speed 100sec).

The measuring and recording conditions of the range, scale, chart speed, etc. can be entered into the PC card in advance, and the unit can be set up with the entered setting contents as occasion demands.

The PC card is an accessory (option). **Use the PC card prepared by our company.**

8-17-2 Mounting

Insert the PC card into the PC card insertion port at the lower left of the chassis with its front face upward.

When the PC card is set correctly, its residual quantity is indicated in the display section and the LED [PC CARD] lights green in the status section.

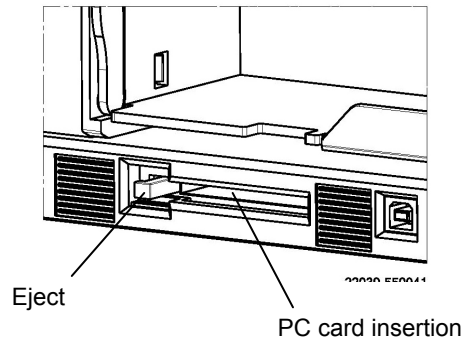
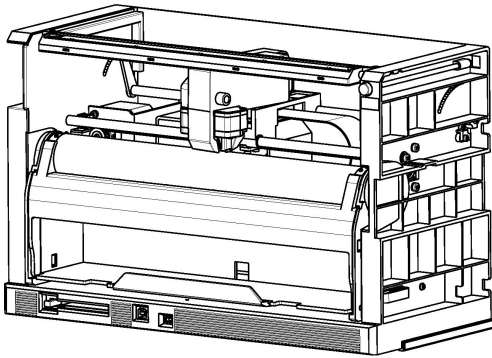

8-17-3 Operation

The operation comprises data writing (DATA WR.) into the PC card, set value saving (PAR.SAVE), readout for a setting change (PAR. LOAD), PC card formatting (FORMAT), and PC card removing (REMOVE).

By inserting the PC card into the unit, an error check is done automatically. If an error exists, the residual quantity of the PC card is displayed red.

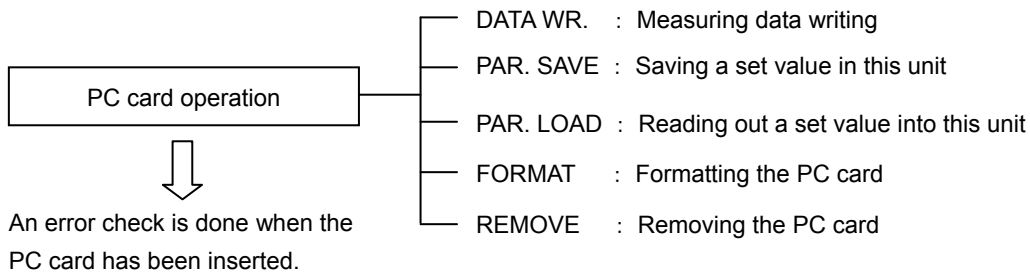

However, residual quantity is red during error checking. After checking, it will turn green.



8-17-4 Handling of PC card

1. Cautions to be observed before use

- The PC card as an accessory of this unit is a CF card with an adapter mounted. The CF card unit cannot be inserted into the unit as it is.
The CF card conforms to CompactFlash™ Specification. Check if the CF card meets the specifications of the unit for the purpose of preventing trouble due to its connector matching failure, etc.
- ◆ Read out the following items for using the CF card safely.
In order to use the CF card safely without any damage to users and the unit, observe the following warning indications.

 WARNING	Negligence of this warning may result in death or serious injuries.
 CAUTION	Negligence of this caution may result in injuries or physical damage.

WARNING

- Never disassemble or modify the CF card, otherwise a fire, an electric shock, or malfunction may occur.
- Don't moisten the CF card nor use it at a place where it is subjected to dew formation, otherwise its internal circuits may be broken.
- Don't remove this product nor handle it near a young child, otherwise drinking by mistake or other dangerous accidents may occur.

CAUTIONS

- Don't use or store this product at a hot, wet or dusty place or a place subjected to the direct sunlight, otherwise a quality drop may occur due to deformation, deflection, or the like.
- Don't give any strong shock to the product due to drop, striking, bending, etc., otherwise the product may be deformed or broken.
- Be careful not to introduce any dust into the connector when storing the product.
- Don't touch the connector (terminals) nor make it contact with any metal, otherwise its internal circuits may be broken due to static electricity.

2. Cautions

- This CF card has been FAT-formatted at the delivery time.
By using the PC card adapter, the CF card can be used as a PC card conforming to PC Card Standard97 16-bit card specification.
- All data are erased by formatting. Confirm the stored data contents before starting formatting.
- Be careful since data in the card may be broken or the unit itself may be broken, if the CF card is taken out or the power supply of the unit to which the CF card is connected is turned off in the course of accessing to it.
- You are requested to understand that we are not responsible for any damage due to the lost or damage of data of the CF card.

CompactFlash™ and CF™ are trademark of US SanDisk Co., and licensed to CFA (CompactFlash™ Association).

8-17-5 PC card setting [PC CARD] common setting

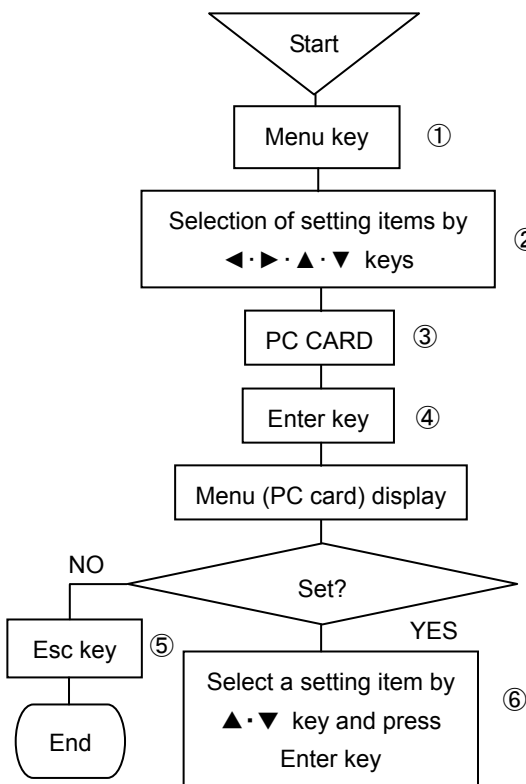

- ① Press Enter key to select the setting display mode.
A window opens and a setting items table is displayed.
- ② Move the cursor by ◀·▶·▲·▼ key to select a desired item to be set.
- ③ Select PC CARD.
- ④ Press Menu key to enter the setting item selection mode.
A window opens and a setting items selection screen is displayed.
(For the setting items selection screen, refer to ⑥)
- ⑤ For stopping the setting, the screen returns to the last one, each time Esc key is pressed once.
- ⑥ Move the cursor to a desired item to be set by ▲·▼ key.

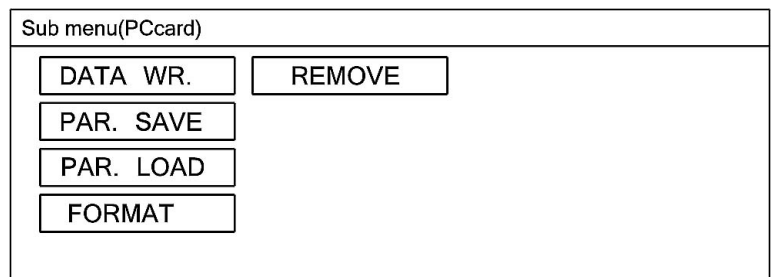

8-17-6 Setting of measuring data saving by PC card [DATA WR.]

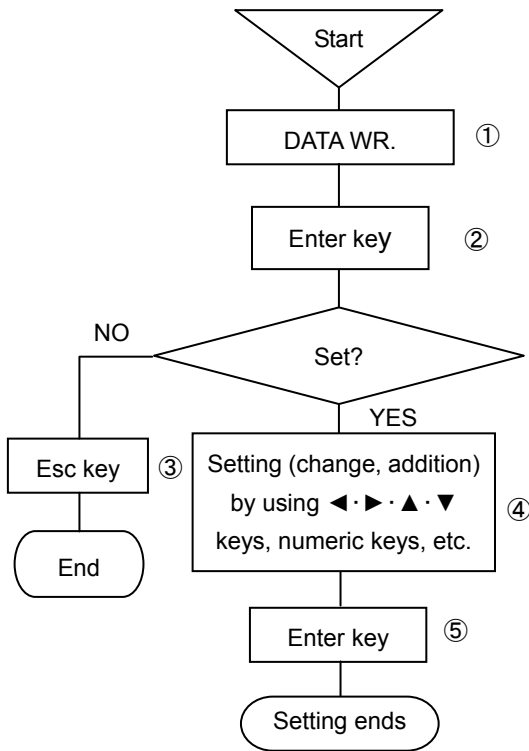

(Note 1)

If the start trigger is set to be [None], measuring data is not saved even if the start time is set.

Set the start trigger to a [Time] without fail when setting the start time. If a set start time is earlier than the present time and minutes, data are started saving at the set start time in the next day.

(Note 2)

Set the start trigger to the position other than [None] if start triggering is done by keying operation (Shift + Rec. keys).

Even if the start trigger is set to a [Time], the start by keying operation (Shift + Rec. keys) takes preference of the start by the designated time.

This also applies to the end trigger, correspondingly.

Neither start triggering nor end triggering is executed by Shift + Rec. keys operation only.

Refer to ※1) on the right side.

Both start triggering and end triggering can be executed irrespective of the display screen.

(Note 3)

If the PC card capacity does not conform to the recording time even if a recording time is designated, the saving work is completed to meet the capacity. When parameter is loaded during saving measuring data, the invalidity data is saved.

(Note 4)

When select [output relay] in start trigger or end trigger, option of contact output (such as alarm output) is needed. When select [external contact], option of external drive is also needed.

① Select DATA WR.

② Press Enter key to select the parameter entry mode of an item to be set.

A window opens and the setting parameter entry screen is displayed. (For the setting parameter entry screen, refer to ④)

③ For stopping the setting, the screen returns to the last one, each time Esc key is pressed once.

④ Move the cursor to the item to be set by ◀▶▲▼ key.

Memory card			
Format	Binary ▼	Start	Hour <input type="text"/> Minute <input type="text"/>
Start TRG	Key(Shift+Rec) ▼	Rec.time	Hour <input type="text"/> Minute <input type="text"/>
End TRG	Key(Shift+Rec) ▼	Interval	0.1s ▼
			Set

The cursor moves in the sequence of Format → Start TRG → Start Hour → Minute → Relay No. → End TRG → Rec.time Hour → Minute → Interval → pre TRG → Set.

1. For parameter input area of the Start Hour and relay No. and Minute and Rec.time Hour and Minute and parameter input area of pre TRG, input setting parameters by numeric keys.

Select one output [800] to [836] for relay No. Pretrigger is [optional setting 0] to [100] by every 1.

**Pretrigger Example: If pretrigger is set [10], start recording the [10] previous data from the time when trigger is ON.

2. For the Format, and Start TRG, and End TRG, and Interval parameters input area, input their setting parameters by numeric keys. A window opens. Select them by using ▲▼ key. For each selection, refer to the following table.

3. After the end of setting on this screen, bring the cursor to .

⑤ Terminate the setting (change, addition) by pressing Enter key.

Press Esc key if the set contents are not saved.

•Format

Binary
Text

•Start TRG

None
Key (Shift + Rec.)
Time
Relay No.
Ext.

•End TRG

Key (Shift + Rec.)
Time
Relay No.
Ext.

Binary : Extension is [l5f]. Data analysis software is necessary to reproduce.

Text : Extension is [txt]. Possible to reproduce with Excel (Microsoft Co.) etc. if necessary.

•Interval

0.1s	0.2s	0.5s	1s	2s
3s	5s	10s	15s	20s
30s	1m	2m	3m	5m
10m	15m	20m	30m	60m

※1) For executing the Start TRG and End TRG by keying operation;

Start TRG : The following message is displayed by pressing Shift + Rec. keys.

[Do you start recording to the memory card?]

Press [Enter] key in case of yes or press [Esc] key in case of no.

When starting the record, display [R] left next to the residual quantity.

End TRG : The following message is displayed by pressing Shift + Rec. keys.

[Do you finish recording to the memory card?]

Press [Enter] key in case of yes or press [Esc] key in case of no.

When finishing the record, disappear [R] left next to the residual quantity.

8-17-7 Setting of set value saving by PC card [PAR.SAVE]

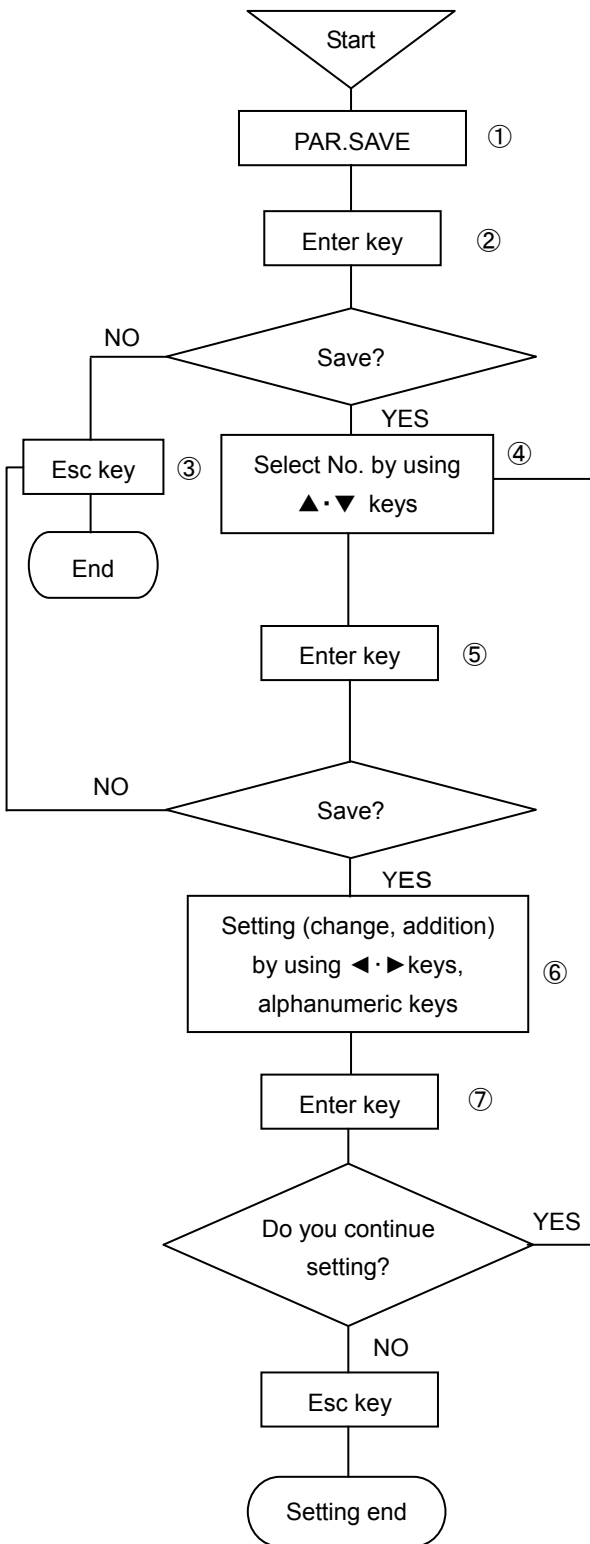

- ① Select PAR. SAVE.
- ② Press Enter key to enter the parameter entry mode of a desired item to be set.
A window opens and a save selection screen is displayed.
(For the save selection screen, refer to item ④)
- ③ For stopping the save, the screen returns to the last one, each time Esc key is pressed once.
- ④ Move the cursor to a desired setting No. by ▲·▼ keys.
The cursor does not move to any item other than No.

RECORD ON		100mm/h	2005/06/14 10:33:28
No.	File name	Up date	
1			
2			
3			
4			
5			
6			
7			
8			
9			
10			

[ESC] : Close [Enter] : Select

- ⑤ Select No. to be set and press Enter key.
A window opens and a setting parameter entry screen is displayed.
(For the setting parameter entry screen, refer to ⑥)
 - ⑥ Press Enter key and set a file name.
- Param. save

File name
- ⑦ Terminate the setting (change or addition) by pressing Enter key.
If the set contents are not saved, press Esc key.

The file name can be input up to max. 8digits by alphanumeric characters.

After the end of setting on this screen, bring the cursor to save.

※ After the end of setting of the file name, press Enter key. Then [file name] is highlighted. Use ▶ key and bring the cursor to save.

(Note 1)

When a file name is entered on the setting parameter entry screen, the update date and time are developed automatically.

(Note 2)

A file name to be set cannot be set by the same file name even if its No. is different.

(Note 3)

For entering a file name, no symbols other than alphanumeric characters can be used.

8-17-8 Setting of reading out a set value by PC card (PAR. LOAD)

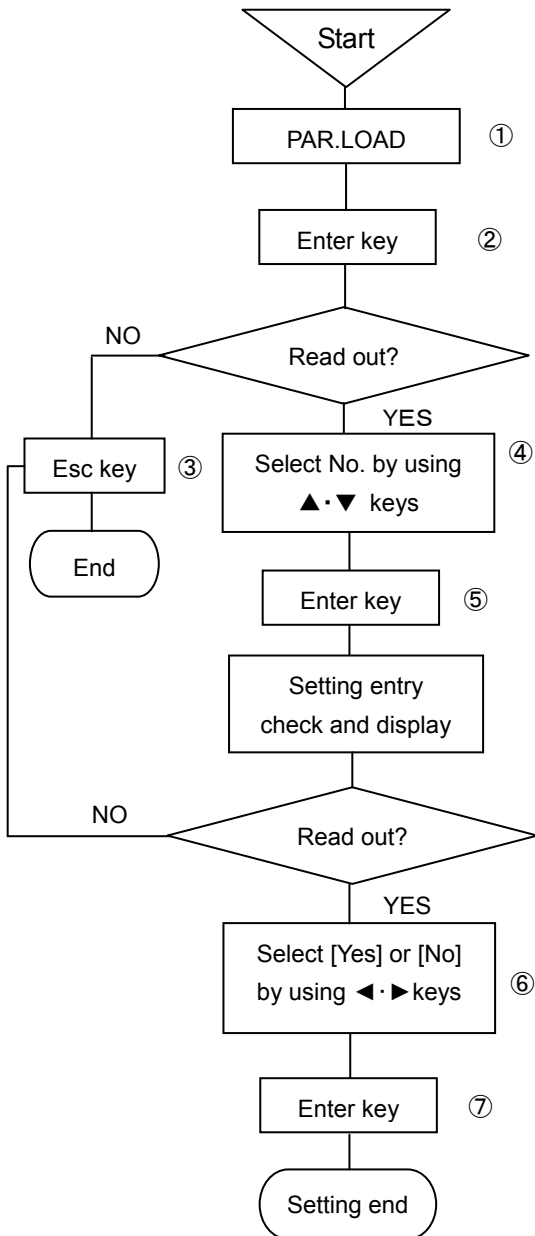

- ① Select PAR LOAD.
- ② Press Enter key to enter the parameter entry mode of a desired item to be set.
A window opens and a setting parameter entry screen is displayed. (For the setting parameter entry screen, refer to item ④)
- ③ For stopping the setting, the screen returns to the last one, each time Esc key is pressed once.
- ④ Move the cursor to a desired No. to be set by ▲·▼ keys.
The cursor does not move to any item other than No.

No.	File name	Up date
1		
2		
3		
4		
5		
6		
7		
8		
9		
10		

RECORD ON 100mm/h 2005/06/14 10:33:28

[ESC] :Close [Enter] :Select

- ⑤ Select No. to be set and press Enter key.
A window opens and a message is displayed to demand either read out a set value or the check. (For the setting parameter entry and check screen, refer to ⑥)
- ⑥ Move the cursor to a desired item to be selected by ◀·▶ keys.

Start loading?

[No] [Yes]

- Select [Yes] when reading out a set value or select [No] if not.
- ⑦ Start reading out the set value by pressing Enter key.
Select [No] or press Esc key if the save contents are not saved.

(Note 1)

When a set value is read out of the PC card, the message display on the display screen turns blue.

(Note 2)

Reading out a set value cannot be stopped halfway.

(Note 3)

When a set value has been read out of the PC card, all present set values are erased. If important set values are present, enter them into the PC card in advance.

8-17-9 PC card format [FORMAT]

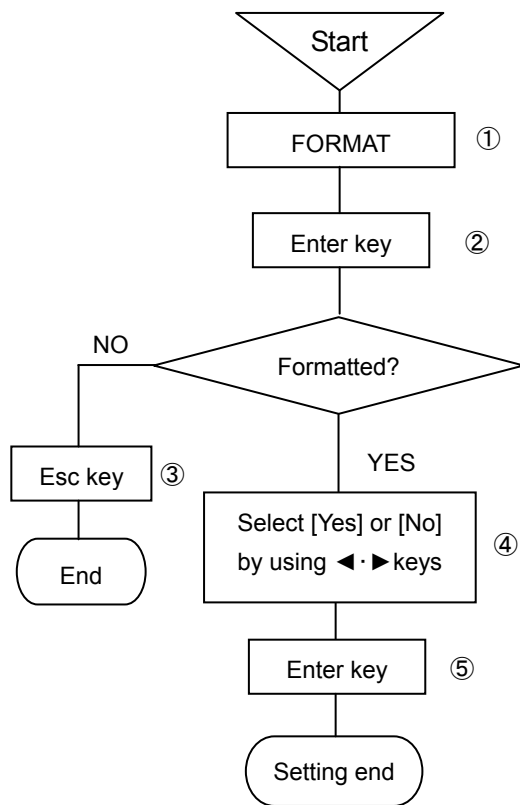

- ① Select FORMAT.
- ② Press Enter key to enter the parameter entry mode of a desired item to be set.
A window opens and a message is displayed to demand either formatting or check.
(For the setting parameter entry and check screen, refer to item ④)
- ③ For stopping the setting, the screen returns to the last one, each time Esc key is pressed once.
- ④ Move the cursor to a desired item to be selected by ◀▶ keys.

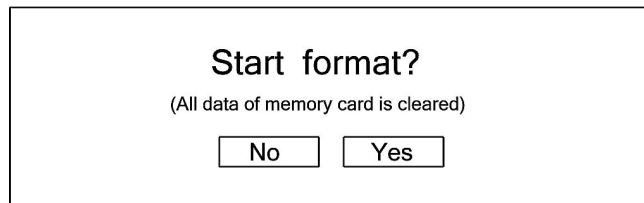

- Select [Yes] if formatted or [No] if not.
- ⑤ Start formatting by pressing Enter key.
Select [No] or press Esc key if formatting is not done.

(Note 1)

The PC card is formatted at the delivery time.
If the PC card has been formatted by a format other than FAT format, formatting is necessary again.
For FAT formatting, format the PC card by FAT16 or FAT32 by means of a personal computer. FAT formatting cannot be done by this unit.

(Note 2)

When the PC card is formatted including the formatting by this unit, all data are erased. Confirm the saved data contents before starting formatting.

8-17-10 PC card removing [REMOVE]

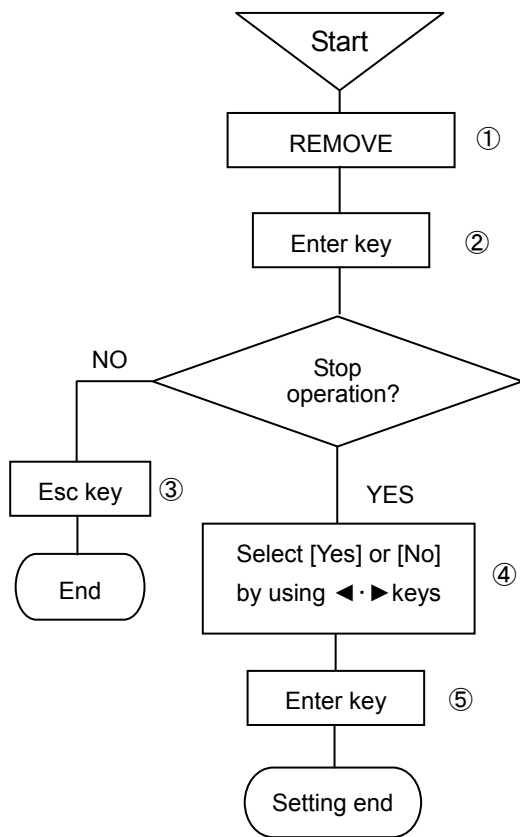

①Select REMOVE.

②Press Enter key to enter the parameter entry mode of a desired item to be set.

A window opens and a message is displayed to demand either stopping operation or check.

(For the setting parameter entry and check screen, refer to item ④)

③For stopping the setting, the screen returns to the last one, each time Esc key is pressed once.

④Move the cursor to a desired item to be selected by ◀▶ keys.

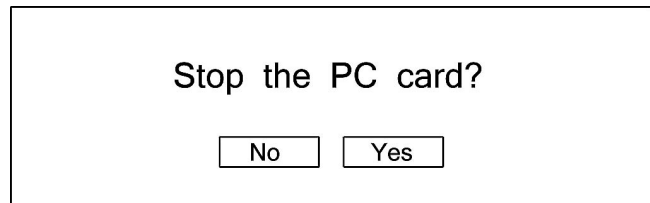

Select [Yes] if stop or [No] if not.

⑤Stop operation by pressing Enter key.

Select [No] or press Esc key if not stop operation.

(Note 1)

It is a cause of trouble if the PC card is removed during operation.

When the PC card is removed, always stop operation of the PC card first.

9-2 Zero and span adjustment of measured values [INPUT ADJ.]

Adjust zero and span if the accuracy is out of the specified value due to an surrounding environment, a secular change, or other causes as calibration results. This zero and span adjustment applies to data display and digital recording to the range setting every channel.

Refer to 8-16. System setting, and enable [Permit input correction setting] beforehand.

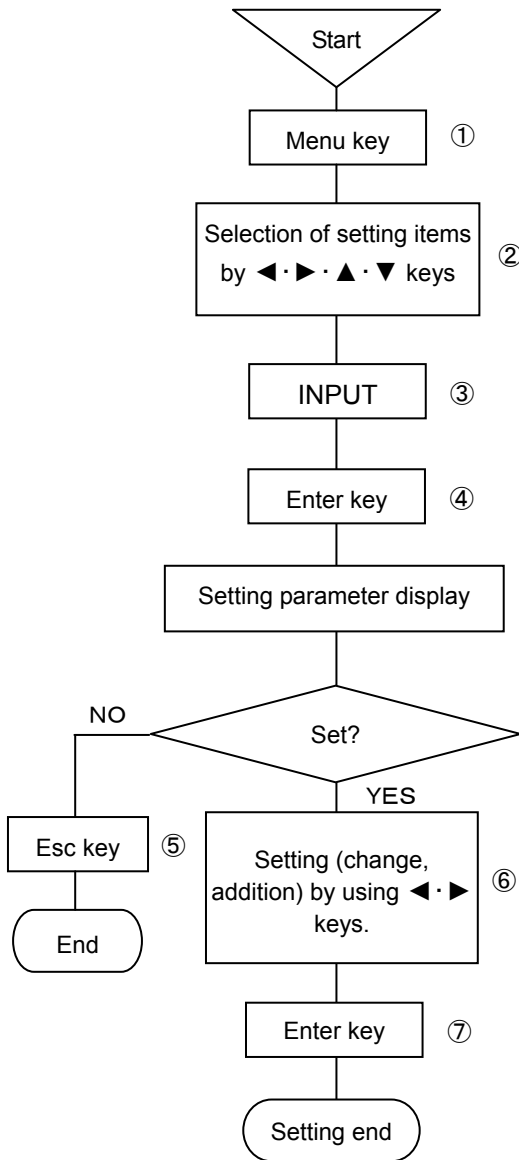

(Caution 1)

Continue feeding power to the unit for longer than 30 minutes for the purpose of stabilizing the unit before starting the adjustment.

(Caution 2)

A wind causes fluctuations of the terminal temperature. Mount the terminal cover in case of thermocouple input, in particular.

(Caution 3)

If analog recording is deviated, adjust zero and span of analog recording.

(Caution 4)

A range setting-free channel is not selectable.

(Caution 5)

If the range is reset to the range before change by changing the range after zero and span adjustment of measured values, adjusted values are cleared and reset to the calibrated values at the delivery time from the factory.

- ① Select the setting display mode by pressing Menu key. A window opens to display a setting items table.
- ② Move the cursor by $\leftarrow \cdot \rightarrow \cdot \blacktriangle \cdot \blacktriangledown$ keys and select an item to be set.
- ③ Select INPUT ADJ.
- ④ Enter the setting table display (collective 12 points) screen by pressing Enter key. (For the setting table display (collective 12 points) screen, refer to ⑥.)
- ⑤ For stopping the setting, the screen returns to the last once, each time Esc key is pressed once.
- ⑥ The cursor moves to a desired channel number to be set by $\blacktriangle \cdot \blacktriangledown$ keys. The cursor does not shift to any item other than CH No.

RECORD ON		100mm/h	2005/06/14 10:33:28
CH.	A	B	
001			
002			
003			
004			
005			
006			
007			
008			
009			
010			
011			
012			

Adj. = A × (Input) + B

ESC : Close Enter : Corr. set Func1 : Next Func2 : Copy

Connect a tester to the channel to be set.

- ⑦ Select a channel to be set and press Enter key. (For the setting parameter entry screen, refer to ⑧.)
- ⑧ The value displayed on the zero side shows the lower-limit value of the range being set by CH PARAM. A higher -limit value of the range is also displayed on the span side.

Adjustment CH001

Input a display value and press button

Zero

Span

Adj. = A × (Input) + B

A B

Zero adjustment

1. Apply the range lower-limit value being displayed on the zero side from the tester.
2. Make sure that the cursor is present on [Zero input] and press Enter key.

Span adjustment

1. Apply the range higher-limit value being displayed on the span side from the tester.
2. Make sure that the cursor is present on [Span input] and press Enter key.

After zero and span have been input, correction values [a], [b] are developed automatically.

※) If a (tilting) and b (intercept) are known in advance, they can input directly by numeric keys.

- ⑧ After the end of setting on this screen, bring the cursor to .
- ⑨ Terminate the setting (change, addition) by pressing Enter key.

9-3 Shift adjustment of measured values

This function is provided to adjust the shift (parallel move) quantity of data display and digital recording. This function is used for correcting the dispersion of sensors, an input converter, etc. This adjustment can be done every channel in two ways.

1. Set a correction value by channel parameter setting [CH PARAM.].
For details, see 8-3.

CH set CH001					
Input	<input type="text"/>	RJ	<input type="text"/>	Burn	<input type="text"/>
Range MIN	<input type="text"/>	Range MAX	<input type="text"/>	Corr.	<input type="text"/>
Scale MIN	<input type="text"/>	Scale MAX	<input type="text"/>	Unit	<input type="text"/>
Record MIN	<input type="text"/>	Record MAX	<input type="text"/>	Tag	<input type="text"/>
Display skip	<input type="text"/>	Digital printing skip	<input type="text"/>		
Memory card rec. skip	<input type="text"/>				<input type="text"/>
					<input type="text"/>

Display the above setting parameter entry screen, and input a correction value to the [Correction] parameter input area by numeric keys. Bring the cursor to and terminate this entry by pressing Enter key.

2. Set a correction value by measured value zero-span adjustment [INPUT ADJ.].
For details, see 9-2.

Adjustment CH001		
Input a displayed value and press button		
Zero	<input type="text"/>	<input type="text"/>
Span	<input type="text"/>	<input type="text"/>
Adj. = A × (Input) + B		
A	<input type="text"/>	B <input type="text"/>
		<input type="text"/>

Display the setting entry screen in the left figure, input [1] to [a] parameter input area, and input a correction value to [b] parameter input area by numeric keys. Bring the cursor to and terminate the entry by pressing Enter key.

(Caution 1)

If a correction value is set in channel parameter setting, a correction value is added when the correction value is set again in zero-span adjustment of measured value.

(Caution 2)

Be careful since the value shifts by an adjusted value during calibration.

(Caution 3)

Feed power to the unit for longer than 30 minutes at least for the purpose of stabilizing the unit before starting the adjustment.

(Caution 4)

A range setting-free channel is not selectable.

9-4 Calibration

Calibration is done every channel, in principle. Even if the same range is set, an error may occur between channels to be exact.

1. Preparation

- ① Turn off the power switch and connect cables according to input signals. (See the following figure)
Connect the input terminals of this unit to a channel to be calibrated.
- ② Mount the terminal cover.
- ③ Turn on the power switch and select one-point sequential display mode.
- ④ Display the channel to be calibrated.
- ⑤ After 30 minutes or longer, start calibration.

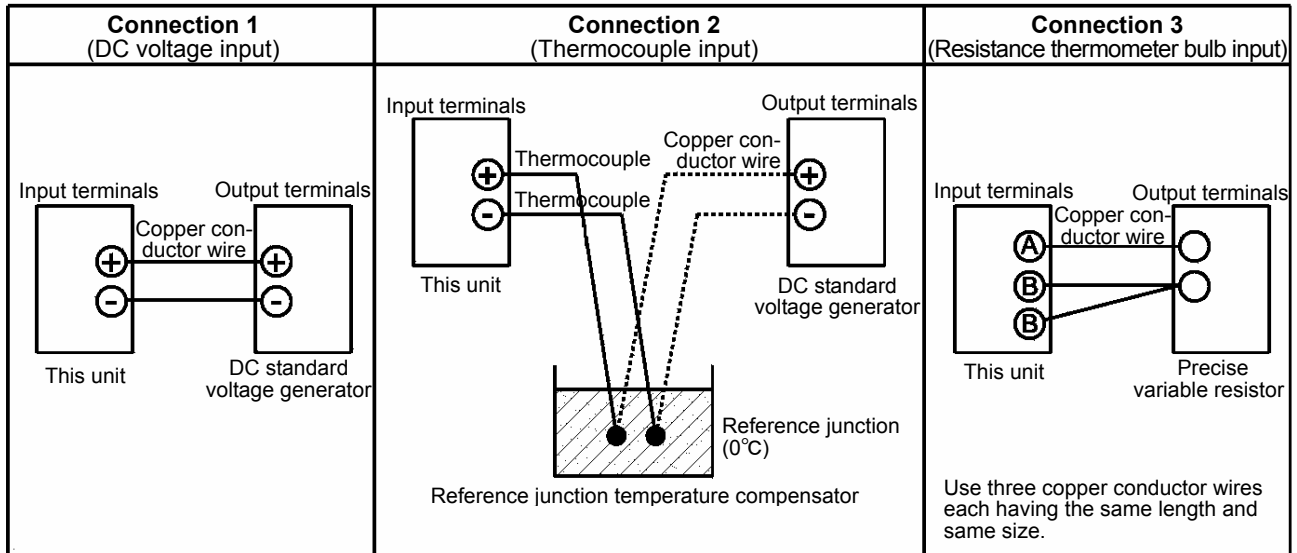

(Caution 1) Accuracy of tester

The basic accuracy of this unit is $\pm 0.05\%$. Accordingly, the calibration does not mean any more unless a tester having the higher accuracy is used. Be careful with a thermocouple error. Be careful since the tester must be stabilized sufficiently before use for securing its accuracy and stability.

(Caution 2) Reference junction temperature compensator

Make sure that the reference junction temperature is 0°C . If an electronic reference junction temperature is used, refer to its instruction manual for connections, etc. Be careful with the compensation accuracy.

(Caution 3) If no reference junction temperature compensator (RJ) is available

Adopt [connection1] if RJ selection is set to [Int] in thermocouple input and no reference junction temperature compensator is available. In this case, set the RJ selector to [Ext] during calibration only. In this case, the reference junction temperature compensation errors cannot be calibrated.

2. Calibration method

- ① Set the tester (DC standard voltage generator or precise variable resistor) to an input value equivalent to the scale to be calibrated.
- ② Read the digital indicating value to check if the error is within the specified accuracy.
- ③ Change the channel to be calibrated next, and observe the same procedure.
- ④ Check the analog indication and dotting positions, too.

(Caution 1) The accuracy of this unit is specified at $23^{\circ}\text{C} \pm 2^{\circ}\text{C}$. Secure the safety of the surrounding environment.

(Caution 2) If the unit is adjusted by the shift adjustment function of measured values, take the deviation into account correspondingly.

(Caution 3) When connections were changed after removing the cover, mount the terminal cover, and then, continue applying power for longer than 30 minutes before starting the calibration work.

10. Troubleshooting

If this unit does not function normally, check it according to the following table.

If the unit is still in trouble after checking it, contact your nearest sales agent or shop from which you bought your unit.

Troubleshooting table

Symptoms	Check contents
(1) The unit does not function at all even when turning on the power switch.	<ul style="list-style-type: none"> ① Check the power terminal connections. (See 4-3-2) ② Make sure that the power voltage is 100–240V AC.
(2) Abnormal noises occur when the printer operates.	<ul style="list-style-type: none"> ① Check if the ribbon cassette is mounted normally. (See 5-2) ② After opening the door, check the printer carriage for foreign substances, and remove them, if any.
(3) Data are displayed, but not recorded at all.	<ul style="list-style-type: none"> ① Make sure that recording is turned on. (REC. ON lights in the status display section) (See 2-3) ② Make sure that the ribbon cassette is mounted. (See 5-2) ③ Check the mounting condition of chart and chart end. (Chart End lamp lights in the display section) (See 1-5 and 5-1)
(4) Printer operates, but the chart does not move.	<ul style="list-style-type: none"> ① Feed the chart manually to make sure that the chart is fed smooth. ② Make sure that the chart is fed smooth by <input type="button" value="Feed"/> key. (See -24)
(5) None of <input type="button" value="Rec"/> key, <input type="button" value="Data P"/> key, and <input type="button" value="Feed"/> key is acceptable.	<p>Check the system setting. (See 8-16)</p> <p>Key Lock lights in the display section in key lock mode.</p>
(6) Range is set, but data are not displayed nor recorded as analog or digital data in a certain channel.	<p>Check the dot setting. (See 8-4)</p>
(7) Setting contents are confirmed to be different even after correct setting.	<p>When setting is entered, a setting change mark is printed. Check the chart.</p>
(8) Normal display mode is not reset even after correct setting.	<p>If the setting change mark is not printed, press Enter key after high-lighting <input type="button" value="Decision"/> of the setting item.</p>
(9) Logging recording is not executed even after setting it.	<ul style="list-style-type: none"> ① Set start time for logging recording is not yet. ② Setting is not correct. (See 8-11) ③ Format [None] is set. (See 8-11)
(10) The unit was operating normally, but malfunction occurred abruptly.	<p>Initialize the setting information. After restoring to normal condition, perform resetting and check if the unit functions normally.</p>

11. Maintenance and check

- ① Carry out the maintenance and check periodically to use the unit under normal conditions at all times.
- ② For the maintenance and check, observe the following table. Replace or supply consumables, and carry out lubrication as occasion demands.

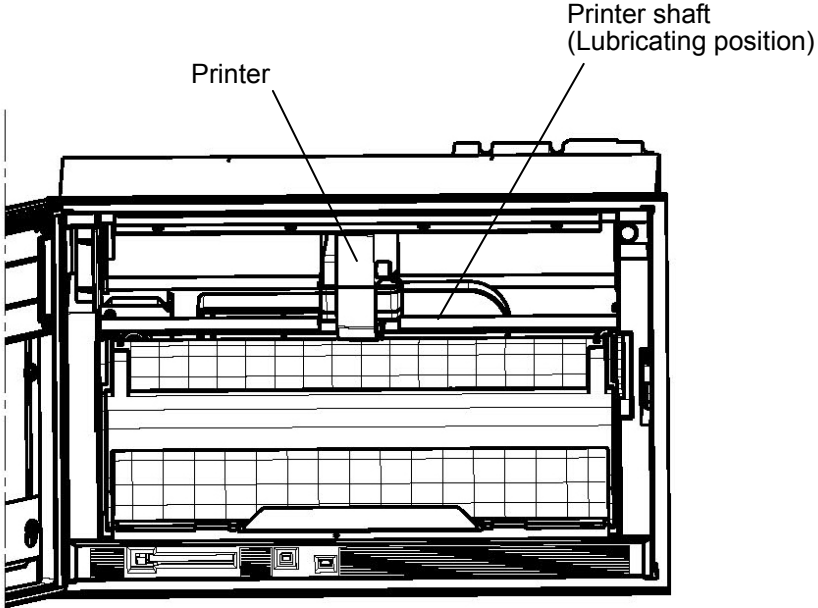
Maintenance and check items	Processing methods
Ribbon cassette exchange	Ribbon cassette lasts for 2—3 months in continuous recording, although its life depends upon the working conditions. When the recording color has become faint, replace the ribbon cassette with new one, referring to [5-2].
Chart exchange	The chart lasts for about one month in continuous run at a chart feed of 25mm/h. When the chart comes to an end, an end mark (red line on the right end of chart) appears. Replace it with new one, referring to [5-1].
Lubrication	<p>Lubricate the dotting and printing printer main shaft once every 6 months.</p> <ol style="list-style-type: none"> (1) Turn off the recording by pressing Rec. key. (2) Turn off the power switch. (3) Remove dirt from the printer main shaft by wiping it off with a soft cloth. (4) Lubricate the main shaft with one or two drops of the attached lubricating oil. <div style="text-align: center;">  </div> <p>(Caution 1) If don't lubricate the main shaft for long time, recording will be distorted.</p> <p>(Caution 2) Use the attached lubricating oil. Don't use any other oil.</p> <p>(Caution 3) Don't lubricate any gears or other places. If oil is attached to resin molds, they may be deformed or broken.</p>
Cleaning	<p>A part of the door frame is made of resin mold. For cleaning it, wipe it off by a soft cloth or a cloth moistened with lukewarm water or a neutral cleaning solvent.</p> <p>(Caution 1) Don't use thinner, benzene, or any other chemicals that dissolve resin molds, otherwise the door frame may be deformed or broken.</p>

11-1 Recommendable parts exchange cycles

It is recommended for using the unit for a long time under normal conditions to replace parts periodically as preventive maintenance.

Warning: Parts exchange

Don't replace any parts other than the chart and ribbon cassette as consumables, otherwise the unit cannot be restored normally, and also, a dangerous accident may occur. For parts exchange, please ask your nearest sales agent.

1. Working conditions

Reference parts exchange cycles are as specified below under the standard conditions. If the ambient conditions are worse than the standard conditions, their lives may shorten.

Items	Conditions, etc.	Items	Conditions, etc.
Temperature	20 to 25°C	Others	① A place free of dust, moisture, and soot ② A place free of vibrations and shocks ③ A place where the unit functions normally without being affected
Humidity	20 to 80%RH		
Working time	8 hours/day		
Corrosive gases	None		

2. Reference part exchange cycles

Part names		Reference exchange cycles	Remarks
Mechanical units or parts	Printer	4–6 years	
	Belt (for driving the printer)	4–6 years	
	Chart drive device	4–8 years	
	Ribbon cassette drive device	4–8 years	
	Various motors	4–6 years	
Electrical units or parts	Power supply unit	4–6 years	At an ambient temperature of 25°C
	Display unit	5 years	At an ambient temperature of 25°C
	Setting keys	4–6 years	
	Relays (Mechanical relays for alarm output)	70,000 times	Resistive load (Less than the rated contact capacity)
		20,000 times	Inductive load (Less than the rated contact capacity)
	EEPROM	7 years	Rewriting frequency: Approx. 100,000 times max.
Lithium battery	7 years		

11-2 Disposal

 Precaution	<p>① A small amount of hazardous substance below the specified level with RoHS directive is included in this recorder.</p> <p>② When disposing the recorder always request a professional to do it, or dispose the recorder in according to the garbage collection method of the each community.</p> <p>③ Separate the box, plastic bags, and cushioning materials the recorder is packaged in according to the garbage collection method of the each community, and please cooperate to recycle.</p>
---	---

12. General specifications

No. of measuring points	: 12 points, 24 points and 36 points in 3 kinds
Kinds of inputs	: Full multi-range (TC, mV, Pt contact) Thermocouple··· B, S, R, N, K, E, J, T, WRe5-WRe26, W-WRe26, PtRh40-PtRh20, NiMo-Ni, Platinel II, U, L DC voltage····· $\pm 10\text{mV}$, $\pm 20\text{mV}$, $\pm 40\text{mV}$, $\pm 80\text{mV}$, $\pm 1.25\text{V}$, $\pm 2.5\text{V}$, $\pm 5\text{V}$, $\pm 10\text{V}$ (A voltage-dividing input is externally provided in the ranges of higher than $\pm 10\text{V}$) DC current····· Shunt resistors ($100\ \Omega$, $250\ \Omega$) are externally mounted Resistance thermometer bulb····Pt100, JPt100 Contact input ····Contact input from external drive (option) (Operation recording by No. of inputs)
Range and scale setting	: Input, type, range, etc. (collective 12 points) are optionally set by front key operation
Indicating accuracy	: Refer to the measuring range, accuracy rating, and display resolution
Measuring cycle	: 100msec
Reference junction compensation accuracy (measurement at higher than 0°C)	: K, E, J, T, N, Platinel II ···Better than $\pm 0.5^\circ\text{C}$ R, S, NiMo-Ni, WRe5-WRe26, W-WRe26, U, L···Better than $\pm 1^\circ\text{C}$ Except for B, PtRh40-PtRh20
Temperature drift	: 0.1%FS/10°C
Allowable signal source resistance	: Thermocouple input (no burnout)·DC voltage input (10mV) Lower than 500 Ω DC voltage input (except 10mV) Lower than 100 Ω Resistance thermometer bulb Lower than 10 Ω per wire
Input resistance	: DC voltage, thermocouple input Higher than 1M Ω
Burn-out	: Decision of an input signal disconnection failure in thermocouple input and resistance thermometer bulb input. Whether the decision is done or not is selectable every input.
Maximum input applied voltage	: $\pm 20\text{V DC}$, $\pm 6\text{V DC}$ (resistance thermometer bulb input)
Maximum common mode voltage	: 30V AC (corresponding to LVD)
Common mode rejection ratio	: More than 130dB (50/60Hz $\pm 0.1\%$)
Normal mode rejection ratio	: More than 50dB (50/60Hz $\pm 0.1\%$) (On condition that the noise peak value is less than the reference range.)
Recording chart	: Folded belt type Total width 318mm Total length 20m Effective recording width 250mm
No. of recording points	: Input ··· 12 points, 24 points, 36 points Arithmetic operation results ··· 36 points
Recording system	: Raster scan system 10 colors Wire dot printing
Recording color	: Analog recording ··· Optional designation is possible every channel 10 colors (green, yellowish green, orange, red, reddish purple, brown, bluish green, purple, bluish purple, black) Digital recording, logging recording ··· Black Tag/scale printing ··· Chart speed ··· 200mm/h or lower : Same as analog recording colors Chart speed ··· 201mm/h or higher : Black Date, time, time line, chart speed, list printing ··· Black Alarm printing/mark (generation/cancellation) ··· Chart speed ··· 200mm/h or lower: Red (when option is added) Chart speed ··· 201mm/h or higher: Black (when option is added)
Chart speed	: 1–1500mm/h (Optional setting every mm/h step)
Recording format	: 1 kind is selectable out of analog recording, analog recording + digital recording, and logging recording (Digital recording: 3 kinds of formats, Data printing/logging recording: 2 kinds of formats) Skip function ······ Skip channels of analog recording, digital recording, and logging recording can be designated independently and optionally.
Recording cycle (Interval)	: Analog recording ····Optional selection out of interlocking dotting with chart speed and interlocking dotting at an optional cycle Digital recording ···· Optional hour and minute setting (within 24 hours) Shortest interval ··· Chart speed interlocking time (Depends upon the number of recording channels and formats) Start time ··· Optional time setting (within 24 hours) Logging recording ···Optional time setting (1 minute–24 hours) Start time ··· Optional time setting (within 24 hours)
Unit	: Optional setting within 8 characters
Tag	: Optional setting within 8 characters

Alarm printing (when option is added)	: Generation or cancellation mark in tag (Channel number in case of non-setting), kinds of alarms, generation and cancellation time, level, and analog recording
Scale printing	: Minimum value, maximum value, tag (Channel number in case of non-setting)
List printing	: All setting parameters printing, designated parameters printing
Message printing	: Optional setting within 80 characters Time is printed Channel designation is also possible (within 75 characters).
Data printing	: Latest data are printed out by [Data P] key.
Differential operation (ΔT)	: A difference between optional channels or a difference from an optional set value
<hr/>	
Display section	: Dot matrix color LCD panel (6.2 inches) of 640 x 240 dots LED status: Alarm (ALM) red, Memory card (PC CARD) green, Recording ON/OFF (REC ON) green
Display contents	: Selectable out of one-point fixed or sequential display, all points collective display, 12-point fixed or sequential display (Unit number display: Type code, serial number, software version number) Status Key lock, chart end, setting decision (format error or setting error), etc. LED status Lights in the occurrence of an alarm, memory card operation, and recording ON
Skip function	: Skip channel is optionally settable (Settable independently of recording skip)
<hr/>	
Operation assembly	: Operation keys ... Entry and setting function keys of various setting parameters by conversational system, recording control keys, alphabetic keys, ten keys, etc.
Card setting function	: Memory card (option) is used.
Exclusive engineering port	: USB port (B type) which is set to PC to set and control all setting parameters. For this operation, exclusive engineering software (option) for PC is necessary.
<hr/>	
Alarm system (option)	: Individual setting, higher limit, lower limit
Setting system	: Individual setting by key operation at each point, 4 levels/channel
Alarm display	: Red LED status lamp lights in the occurrence of an alarm.
Alarm printing	: Tag (channel number in case of non-setting), kinds of alarms, level, generation and cancellation time at the right end Generation and cancellation marks on analog recording
Alarm output	: 3 kinds of 12 points, 24 points, and 36 points (AND output and OR output can be designated) Contact capacity: 100V AC 0.5A resistive load, 240V AC 0.2A resistive load, 30V DC 0.3A resistive load
<hr/>	
Power supply	: 100V AC—240V AC (50/60Hz)
Power consumption	: Approx. 100VA
Working temperature range	: 0 to 40°C *during transportation and storage : -25 to 60°C
Working humidity range	: 20 to 80%RH *during transportation and storage : 5 to 95%RH (no condensation)
Countermeasures against power interruption	: Set values protection ... EEP, ROM Clock ... Backed up for longer than 5 years by lithium battery
Insulation resistance	: 500V DC, 20M Ω or higher between primary terminals and protective conductor terminals 500V DC, 20M Ω or higher between secondary terminals and protective conductor terminals 500V DC, 20M Ω or higher between primary terminals and secondary terminals
Dielectric strength	: 1500V AC, 1min between primary terminals and protective conductor terminals 500V AC, 1min between secondary terminals and protective conductor terminals 1500V AC, 1min between primary terminals and secondary terminals (Note 1) Primary terminals: Power terminals, alarm output terminals, output relay terminals Secondary terminals: Measuring input terminals, communication terminals, external drive terminals (Note 2) Short all primary and secondary terminals before starting the insulation resistance and/or dielectric strength test, otherwise the unit may be broken
Internal illumination	: White LED
System error alarm	: [Fail] display and relay output (Relay output (option) contact capacity: 100V AC 0.5A, 200V AC 0.2A) when the unit is in trouble
Chart end detection	: Chart End] display and relay output at the end of chart (Relay output: option Contact capacity: 100V AC 0.5A, 200V AC 0.2A)
Key lock	: By operation key operation (A password input is necessary) [Key Lock] display
<hr/>	
Case	: Front door ... Aluminum die cast (Operation assembly is made of ABS resin) Rear case ... Normal steel plate
Painting color	: Door and case ... Color equivalent to DIC546 1/2 Operation assembly ... Color equivalent to DIC549
Mounting method	: Panel embedded mounting, Position ... Horizontal in lateral direction Forward tilting 0 degree, Backward tilting ... Within 15 degrees
Terminals	: Input terminals, alarm output terminals ... M3.5, Others ... M4
Weight	: Approx. 15kg

*When it is high humidity in that condition of transportation and storage, readjustment will be needed. For detail of readjustment, refer to instruction manual 9-4. Calibration.

■ Measuring ranges, accuracy rating, and display resolution

Kinds of inputs		Measuring ranges	Reference range	Accuracy rating	Display function
DC voltage		-10.0 to 10.0mV	±10mV	±0.05%±1digit	1μV
		-20.0 to 20.0mV	±20mV		
		-40.0 to 40.0mV	±40mV		10μV
		-80.0 to 80.0mV	±80mV		
		-1.25 to 1.25V	±1.25V		100μV
		-2.5 to 2.5V	±2.5V		
		-5.0 to 5.0V	±5V		1mV
		-10.0 to 10.0V	±10V		
Thermocouple	K	-200 to 500°C	±20mV	±0.05%±0.5°C	0.1°C
		-200 to 900°C	±40mV		
		-200 to 1370°C	±80mV		
	E	-200 to 250°C	±20mV	±0.05%±0.7°C	
		-200 to 500°C	±40mV		
		-200 to 900°C	±80mV		
	J	-200 to 350°C	±20mV	±0.05%±0.7°C	
		-200 to 700°C	±40mV		
		-200 to 1200°C	±80mV		
	T	-200 to 400°C	±20mV	±0.05%±0.7°C	
	R	0 to 1760°C	±20mV	±0.05%±1°C	
	S	0 to 1760°C	±20mV		
	B	0 to 1820°C	±20mV		
	N	0 to 600°C	±20mV	±0.1%±0.1°C	
		0 to 1000°C	±40mV		
		0 to 1300°C	±80mV		
	W-WRe26	0 to 2315°C	±80mV	±0.1%±1°C	
	WRe5- WRe 26	0 to 2315°C	±80mV		
	PtRh40-PtRh20	0 to 1888°C	±20mV		
	NiMo-Ni	-50 to 1310°C	±80mV	±0.1%±0.1°C	
	Platinel II	0 to 500°C	±20mV		
0 to 950°C		±40mV			
0 to 1395		±80mV	±0.1%±1°C		
U	-200 to 350°C	±20mV	±0.05%±1°C		
	-200 to 600°C	±40mV			
L	-200 to 350°C	±20mV	±0.05%±1°C		
	-200 to 700°C	±40mV			
	-200 to 900°C	±80mV			
Resistance thermometer bulb	Pt100	-50 to 50°C	50Ω	±0.05%±0.3°C	0.1°C
		-100 to 130°C	100Ω		
		-200 to 250°C	200Ω		
		-200 to 550°C	300Ω		
	JPt100	-50 to 50°C	50Ω		
		-100 to 130°C	100Ω		
		-200 to 250°C	200Ω		
		-200 to 550°C	300Ω		

(Caution 1) Accuracy at a room temperature of 23°C±2°C (Caution 2) Thermocouple input does not include any reference junction compensation accuracy (Caution 3) Burnout is OFF (Caution 4) Accuracy rating shows % to the measuring range

K, E, J, T, R, S, B, N : IEC584, JIS C1602-1995

W-WRe26, WRe5-WRe26, PtRh40-PtRh20, NiMo-Ni, Platine II : ASTM Vol. 14. 03

U(Cu-CuNi), L(Fe-CuNi) : DIN43710

Pt100 : IEC751, JIS C1604-1997

JPt100 : JIS C1604-1981, JIS C1606-1986

■ **Exceptional standards of accuracy rating**

Note) Each reference range conversion accuracy applies to thermocouple inputs.

Kinds of inputs	Measuring ranges	Accuracy rating
K, E, J, T, L	-200 to 0°C	±0. 2%±1 digit
R, S	0 to 400°C	
B	0 to 400°C	Not specified
	400 to 800°C	±0. 15%±1 digit
U	-200 to 0°C	±0. 3%±1 digit
W-WRe26	0 to 300°C	
PtRh40-PtRh20	0 to 300°C	±1. 5%±1 digit
	300 to 800°C	±0. 8%±1 digit
NiMo-Ni	-50 to 100°C	±0. 2%±1 digit

13. Option specifications

Option names	Option contents									
External mounting of voltage divider	<p>A 1/1000 voltage divider can be mounted externally every channel. As a result, inputs up to DC voltage 50V can be measured.</p> <p>Voltage division ratio : 1/1000 Voltage division accuracy : $\pm 0.1\%$ Applicable models : All models</p> <p>[Caution] Not applicable together with burnout and current input.</p>									
External mounting of current input unit	<p>This unit is used for measuring current inputs every channel.</p> <table border="1" data-bbox="360 472 1050 591"> <thead> <tr> <th>Input</th> <th>Receiving resistance</th> <th>Output</th> </tr> </thead> <tbody> <tr> <td>4 to 10mA</td> <td>250Ω</td> <td>1 to 5V</td> </tr> <tr> <td>10 to 50mA</td> <td>20Ω</td> <td>200mV to 1V</td> </tr> </tbody> </table> <p>Resistance accuracy : $\pm 0.1\%$ Applicable models : All models</p> <p>[Caution] Not applicable together with voltage divider inputs.</p>	Input	Receiving resistance	Output	4 to 10mA	250Ω	1 to 5V	10 to 50mA	20Ω	200mV to 1V
Input	Receiving resistance	Output								
4 to 10mA	250Ω	1 to 5V								
10 to 50mA	20Ω	200mV to 1V								
External drive	<p>Chart speed selection (3 stops + stop) and data printing start can be done by external contact signals.</p>									
Recording format	<p>Analog recording format can optionally be designated. (Mixed use is not allowable)</p> <p>① Parallel scale: Recording range is divided into optional designation areas to record data. ② Partial compression and enlarged recording: A specified recording range can optionally be enlarged or contracted for recording. ③ Automatic range selection: If a measured value exceeds the higher-limit set value or lower-limit set value of recording, it is recorded by switching the recording range.</p>									
Change ratio and differential alarms	<p>① Change ratio alarm: Alarm operation (lifting limit, lowering limit) is done to a change width every fixed time of input. ② Differential alarm: Alarm operation (differential higher-limit, differential lower-limit) is done to an absolute value of a difference of 2 inputs.</p> <p>[Caution] Differential operation (inter-channel value, fixed value) function is provided as standard equipment.</p>									
Basic operation (Operation results recording)	<p>The following operation data processing can be done and these processing data can be recorded and output by means of communication. Max. 36 processing data can be processed.</p> <p><Operation mode> ① Time series (Optional setting: Max. 24 hours) ② Inter-channel</p> <p><Kinds of arithmetic operation> ① Maximum ② Minimum ③ Averaging ④ Total (integration)</p>									
Individual alarm outputs	<p>Individual alarm outputs of 12, 24, and 36 points can be added (OR and AND outputs are selectable).</p>									
Communication interface	<p>Interface to couple with host CPU</p> <p><Functions> ① Various setting ② Data output ③ Setting information ④ Recording control ⑤ Printing control</p> <p><Kinds> RS-422A or RS485 (switched by connections) + Ethernet</p>									
Designated painting color	<p>Door and case are painted with designated colors.</p>									
Attachment panel for mounting JIS rack	<p>JIS rack mounting attachment panel Applicable model: All LE5 models</p>									
Desk-top type case	<p>This case is provided with a tilting-enable stand, rubber mounts, and grips for transportation.</p>									

13-1. External drive

Chart speed can be selected and data can be printed by external contact signals (no-voltage contacts: short-circuit or open) without any setting keying operation. One of 3 chart speeds and stop can be selected. Three kinds of chart speed can be set optionally by keying operation of this unit, and also, the dotting synchronizing mode can be set every chart speed.

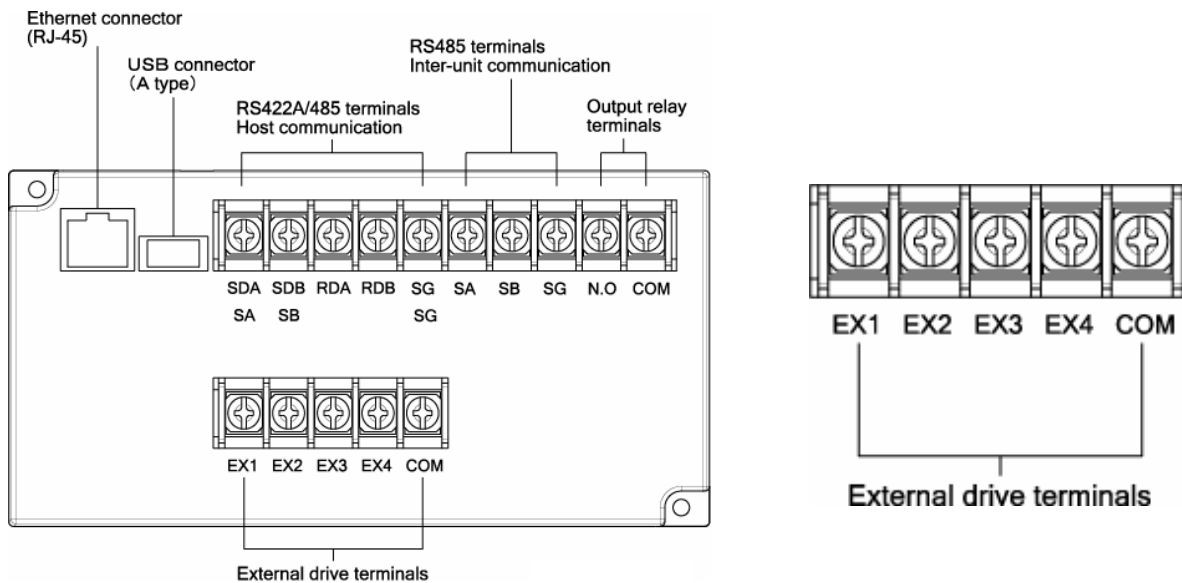

【Operation selection】

External drive functions and inter-terminal conditions

External drive functions	Across COM—EX□ terminals				Remarks
	EX1	EX2	EX3	EX4	
Chart speed 1	OFF	OFF	OFF	OFF	Rec/Feed operation by setting keys is effective. When select M. card TRG, selection of chart speed is 2 kinds.
Chart speed 2	ON	OFF	OFF	OFF	
Chart speed 3 or M. card TRG	OFF	ON	OFF	OFF	
Recording execution and stop	OFF	OFF	ON	OFF	Feed operation by setting keys is ineffective. When EX3 is turned on, the recording is stopped.
Data printing execution	OFF	OFF	OFF	ON	Turn on EX4 for longer than 1 second.

(Note 1) A chart speed being selected by an external contact is displayed.

(Note 2) If [Rec. OFF] is selected by keying operation, the chart speed display changes, but the unit is set to [Rec. OFF] condition.

(Note 3) If [Stop] is selected by an external contact, the unit is set to [Rec. OFF] condition, irrespective of the keying operation and setting by means of communication. If a set value is confirmed when [Rec. OFF] is set by keying operation or communication under this condition, a [Rec. ON] condition returns, but the unit is set to [Rec. OFF] condition. [RECORD OFF] is displayed blue.

(Note 4) An interval time in data interval setting is judged according to the chart speed being selected at the setting time. If a chart speed is selected after setting, the set interval recording may be impossible. In such a case, data interval recording is done at an interval as short as possible at the chart speed.

(Note 5) If data printing is demanded by shorting external drive terminals when data are being printed, the executing data printing is continued, and data printing is executed again at the end. However, even if data printing is demanded several times when data are being printed, data printing is done successively by once only.

(Note 6) The short time between COM-EX4 terminals must be longer than 1 second at least. Since data are printed by a change of open condition → short-circuit condition, data printing cannot be repeated even if the short-circuit is continued.

[Example: Chart speed selection by an alarm output]

Set another alarm to a value which is more or less lower than the necessary alarm point, and switch the chart speed by its output. Thus, detail records of measuring data before and after the necessary alarm point can be obtained.

Alarm setting

- Necessary alarm point : Higher-limit 1000°C (alarm output 3)
- Chart speed switching alarm contact : Higher-limit 800°C (alarm output 1)
- Chart stop alarm point : Higher-limit 1200°C (alarm output 2)

Chart speed setting

- Chart speed 1 : 5mm/H
- Chart speed 2 : 50mm/H

Measuring data	Chart speed
Lower than 800°C	5mm/H
800 to 1200°C	50mm/H
Higher than 1200°C	Stop

[Connection example]

An example of the selection of chart speeds by an alarm output

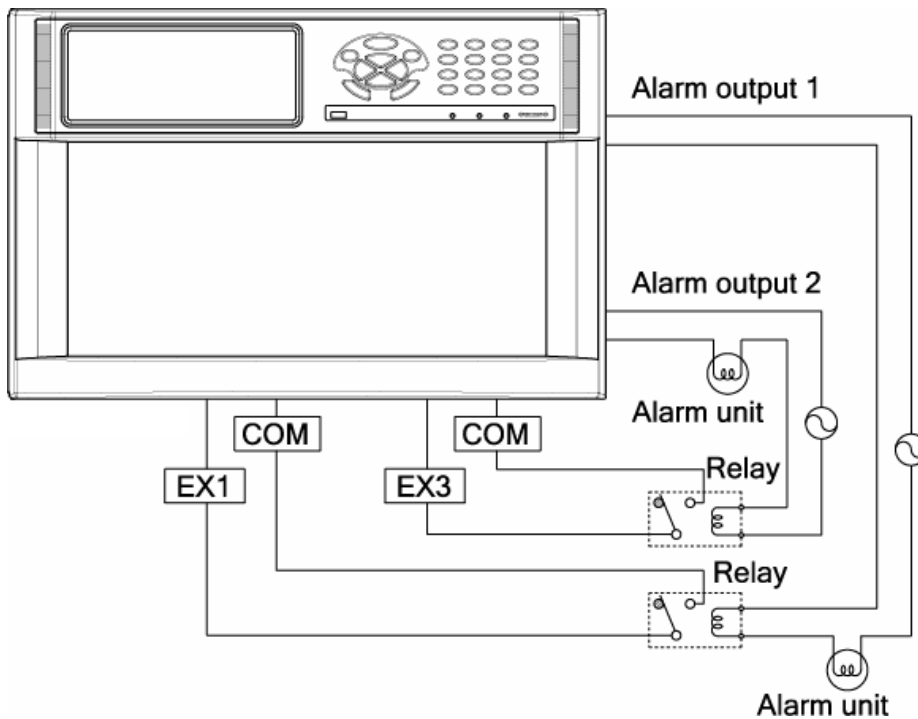

Description of operation in the above example

- ① The chart speed is 5mm/H when no alarm occurs.
- ② If a measured value becomes higher than 800°C, alarm output 1 turns on and the chart speed is switched to 50mm/H.
- ③ If a measured value becomes higher than 1200°C, alarm output 2 turns on and the recording stops.

【Setting method】

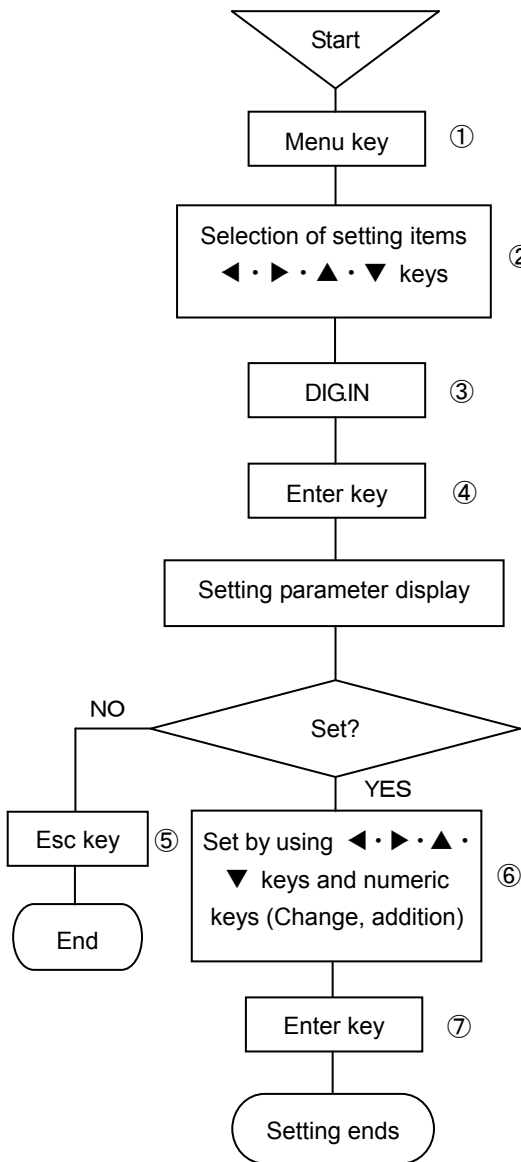

(Note 1)

If EX1 – EX4 are selected to be [No], the function being assigned to each terminal does not work even if external contact operation is done.

(Note 2)

If an optional cycle is selected with the dotting synchronization, the optional cycle must be set in [Chart recording setting]. For setting an optional speed, refer to [I. Instruction Manual].

Optional speed setting ----- 8-5 Chart recording setting.

(Note 3)

When select M. card TRG in EX2, cannot switch to chart speed 3.

- ① Press Menu key to enter the setting display mode. A window opens and a setting items table is displayed.
- ② Select a desired item to be set by moving the cursor by means of ◀ • ▶ • ▲ • ▼ keys.
- ③ Select DIG.IN.
- ④ Press Enter key to enter the parameter entry mode of the desired item to be set.
A window opens and a setting parameter entry screen is displayed.
(For the setting parameter entry screen, refer to ⑥)
- ⑤ For stopping the setting, press Esc key. The screen returns to the last one, each time Esc key is pressed once.
- ⑥ Move the cursor to a desired item to be set by ◀ • ▶ • ▲ • ▼ keys.

External drive			
EX1	None ▼	Chart speed 2	25
EX2	None ▼	Dot sync 2	Chart speed ▼
EX3	None ▼	Chart speed 3	25
EX4	None ▼	Dot sync 3	Chart speed ▼
			Set

Each time Enter key is pressed once, the cursor moves in the sequence of EX1 → EX2 → EX3 → EX4 → chart speed 2 → Dot sync 2 → chart speed 3 → Dot sync 3 → Set.

1. The EX parameter input area is determined by selecting a setting parameter.
A window opens. Select the parameter by ▲ or ▼ key.
For selecting EX1 to EX4, refer to the following table.
2. Input a setting parameter by using numeric keys in the chart speed parameter input area.
In this case, set an optional chart speed in units of 1mm/h within a range of 1mm/h to 1500mm/h. (This is set to 25mm/h at the delivery time from the factory.)
3. The Dot sync parameter input area is determined by selecting a setting parameter. A window opens. Select the parameter by ▲ or ▼ key.
For selecting EX1 to EX4, refer to the following table.
4. After setting this screen, bring the cursor to Set.
- ⑦ Terminate the setting (change, addition) by pressing Enter key.

EX1 to EX4

EX1	EX2	EX3	EX4
None	None	None	None
Chart speed 2	Chart speed 3	Record ON/OFF	Data print
	M. card TRG		

Dot sync.

Chart speed
Set cycle

13-2. Alarm output

Three kinds of alarm output points (12 points, 24 points, and 36 points) are prepared. Confirm the model code. For the alarms and setting and connections of alarm outputs, refer to [I . Instruction Manual].

1. Alarms and alarm output setting ----- 8-6 Alarm setting

Setting and assignment of alarm output channels are as shown below. Be careful since any setting other than specified in the following table cannot be done.

No. of output points	Channel No.	Output relay No. setting
12 points	1 to 12	801 to 812
24 points	1 to 24	801 to 824
36 points	1 to 36	801 to 836

Example

For outputting to alarm output terminal channel 1, set output relay No. to [801]

2. Connections ----- 4-3 Connections of each section 4-3-4 Alarm output terminals

3. Failure output setting

A failure output can be sent to alarm output terminals. For the setting method, observe the following procedure.

【Setting method】

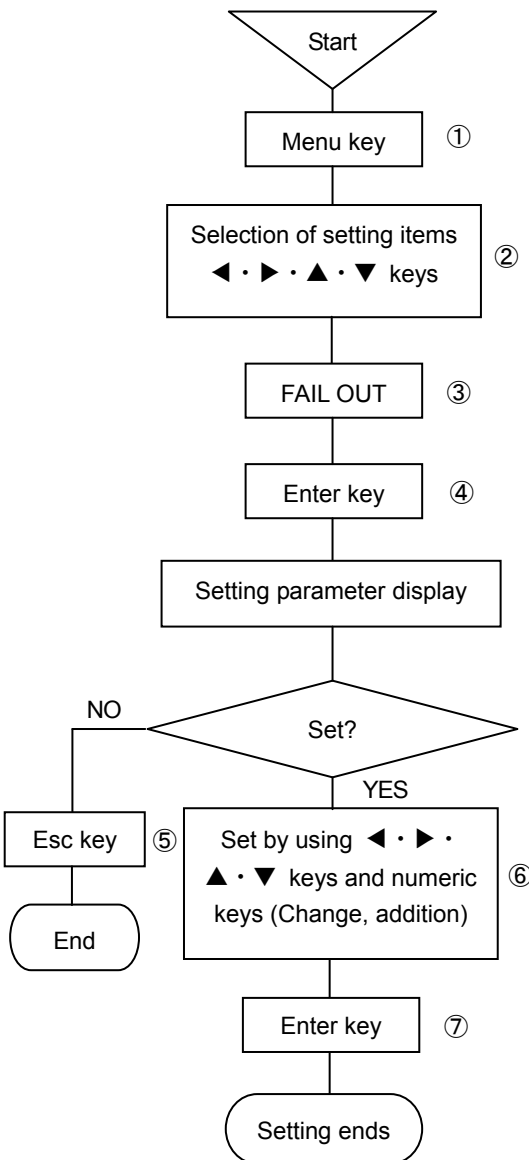

- ① Press Menu key to enter the setting display mode.
A window opens and a setting items table is displayed.
- ② Select a desired item to be set by moving the cursor by means of ◀ • ▶ • ▲ • ▼ keys.
- ③ Select FAIL OUT.
- ④ Press Enter key to enter the parameter entry mode of the desired item to be set. A window opens and a setting parameter entry screen is displayed.
(For the setting parameter entry screen, refer to ⑥)
- ⑤ For stopping the setting, press Esc key. The screen returns to the last one, each time Esc key is pressed once.
- ⑥ Move the cursor to a desired item to be set by ◀ • ▶ • ▲ • ▼ keys.

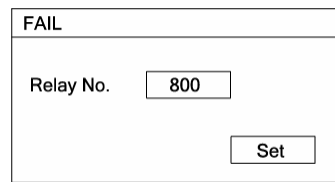

Each time Enter key is pressed once, the cursor moves in the sequence of Relay No. → Set. Input a setting parameter to the parameter input area at the output destination by pressing numeric keys. Setting is as shown below.

Any setting other than described below cannot be done.

No. of output points	Settable output relay No.
12 points	801–812
24 points	801–824
36 points	801–836

When the communication interface is attached, output relay No. 800 can be designated in addition to the above numbers.

After setting this screen, bring the cursor to Set .

- ⑦ Terminate the setting (change, addition) by pressing Enter key.

(Note1)

Failure output destination is set to [800] at the delivery time from our factory.

When the communication interface is specified to be provided, a failure output signal is sent to output relay No. 800. However, when the communication interface is specified to be not provided, but the alarm output is specified to be sent, a channel must be set out of 801–836, referring to the above table.

13-3. Recording format

The analog recording format can be changed by selecting one of the following records. Select them according to uses.

- AUTO RNG — Recording ranges are selected automatically according to input sizes.
- COMP — The analog recording range is partially compressed or expanded.
- PARALLEL — The analog recording range can be divided into max 5 areas.

(Note1) No recording format can be selected individually every channel.

(Note2) The present specification selects the analog recording formats. Input sensitivity and accuracy are decided according to the ranges.

【Setting method】

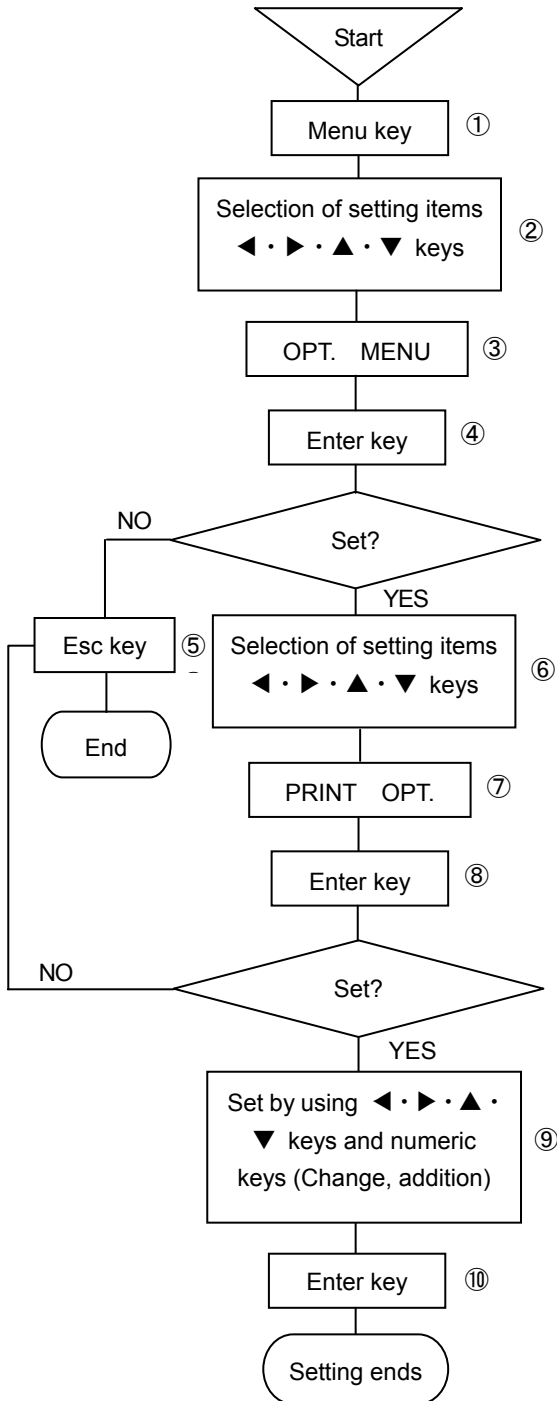

- ① Press Menu key to enter the setting display mode.
A window opens and a setting items table is displayed.
- ② Select a desired item to be set by moving the cursor by means of ◀ • ▶ • ▲ • ▼ keys.
- ③ Select OPT. MENU.
- ④ Display an option setting items table by pressing Enter key.
(For the option setting table screen, refer to ⑥)
- ⑤ For stopping the setting, press Esc key. The screen returns to the last one, each time Esc key is pressed once.
- ⑥ Move the cursor to a desired item to be set by ◀ • ▶ • ▲ • ▼ keys.

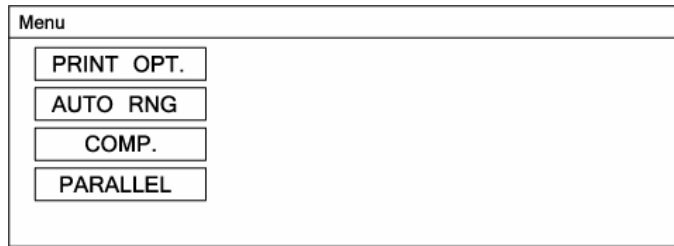

- ⑦ Select PRINT OPT.
- ⑧ Press Enter key to enter the parameter entry mode of the desired item to be set. A window opens and a setting parameter entry screen is displayed.
(For the setting parameter entry screen, refer to ⑨)
- *) For stopping the setting, refer to ⑤.
- ⑨ Move the cursor to a desired item to be set by ◀ • ▶ • ▲ • ▼ keys.

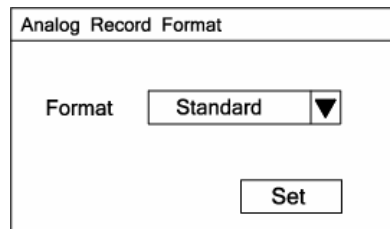

The format parameter input area is selected by selecting a setting parameter. Bring the cursor to the format to be used.

Refer to the following list for using format.

Standard
AUTO RNG
COMP.
PARALLEL

After setting this screen, bring the cursor to **Set** .

- ⑩ Terminate the setting (change, addition) by pressing Enter key.

13-3-1. Automatic range selection recording

- Recording ranges can be set up to max. 5 stages every channel.
- Each range is automatically selected to the next range when it exceeds zero or span of each stage by 0.5mm on the analog trace.
- The relation between range stage number and each span setting is No.1 zero < No.1 span < No.2 span < No.3 span . . .

【Setting method】*Set the following settings after checking if the [AUTO RNG] is selected on analog recording format (p13-6).

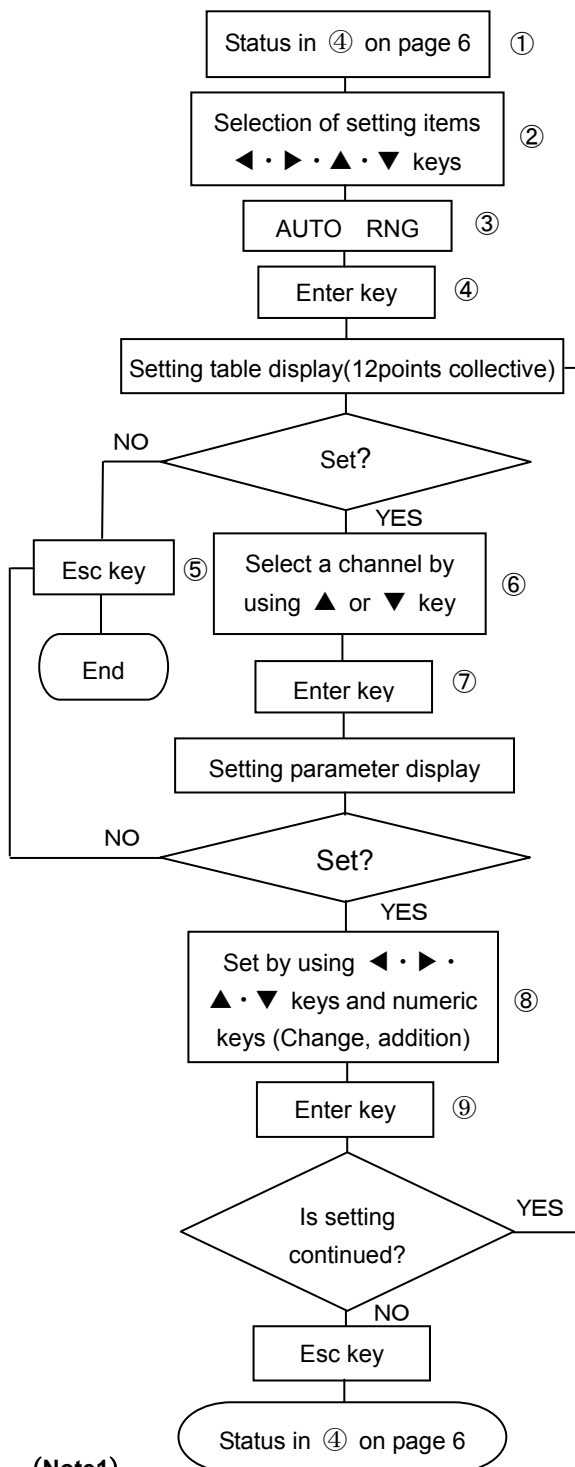

(Note1)

If a set value at the higher limit of No.1 range is equal to or less than a set value at the lower limit of No.1 range, the setting is not acceptable. This also applies to the higher-limit of No.2 range, higher-limit of No.3 range . . . , correspondingly.

- Select OPT. MENU to enter the setting display mode, referring to page 6. A window opens and a setting items table is displayed.
- Select a desired item to be set by moving the cursor by means of ◀ • ▶ • ▲ • ▼ keys.
- Select AUTO RNG.
- Press Enter key to enter the setting table display (12 points collective) screen.
(For the setting table display (12 points collective) screen, refer to ⑥)
- For stopping the setting, press Esc key. The screen returns to the last one, each time Esc key is pressed once.
- Move the cursor to a desired channel number to be set by ▲ or ▼ key.

The cursor does not move to any item other than CH. No.

RECORD ON		100mm/h		2005/06/14 10:33:28				
CH.	Auto Cng.	1st Rng.		2nd Rng.	3rd Rng.	4th Rng.	5th Rng.	
		MIN	MAX	MAX	MAX	MAX	MAX	
001	OFF							
002	OFF							
003	OFF							
004	OFF							
005	OFF							
006	OFF							
007	OFF							
008	OFF							
009	OFF							
010	OFF							
011	OFF							
012	OFF							

ESC : Close Enter : Setting Func2 : Copy

- After selecting a channel to be set, press Enter key.
A window opens and a setting parameter entry screen is displayed.
(For the setting parameter entry screen, refer to ⑧)
- Move the cursor to a desired channel number to be set by ◀ • ▶ • ▲ • ▼ keys.

Auto Range Record CH001

Auto Range ON ▼

1st Range MIN 1st Range MAX 2nd Range MAX

3rd Range MAX 4th Range MAX 5th Range MAX

Each time Enter key is pressed once, the cursor move in the sequence of Auto Range → 1st Range MIN → 1st Range MAX → 2nd Range MAX → 3rd Range MAX → 4th Range MAX → 5th Range MAX → Set.

The Auto Range selection parameter input area is determined by selecting a setting parameter. A window opens. Select a parameter by ▲ or ▼ key.

After setting this screen, bring the cursor to .

- Terminate the setting (change, addition) by pressing Enter key.
- For copying a set value, press [Func 2] key in the screen in ⑥.

Input the copy source and copy destination by numeric keys.

After the end of setting, bring the cursor to and press [Enter] key.

13-3-2. Partial compression and expansion recording

- This setting can be done every channel.
- Since maximum 2 dots can be set, maximum 3 compression or expansion ranges are obtained.
- Set the dot recording position by % and then, set an analog recording scale value at the dot (%).

【Setting method】*Set the following setting after checking if the [COMP.] is selected on analog recording format (p13-6).

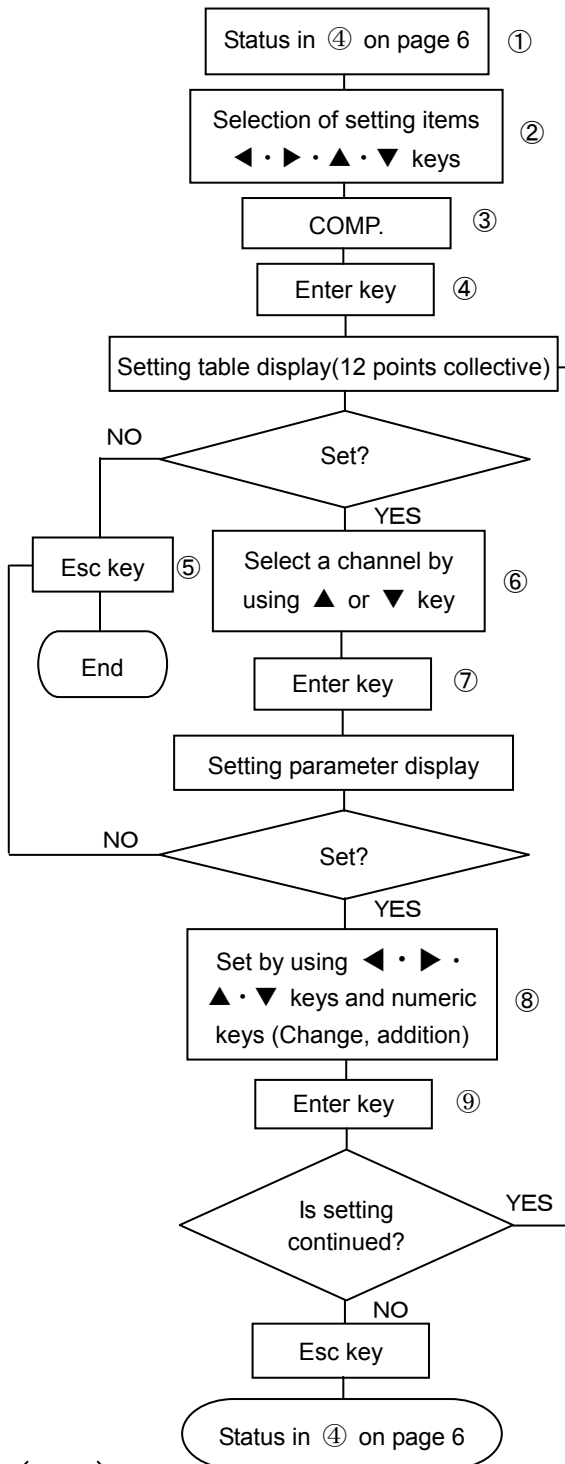

(Note1)

Set the recording position (%) to 0% – 100% in the 0mm – 250mm chart. Set the recording range by a scale value at the set recording position. Be careful with the decimal point position.

- ① Select OPT. MENU to enter the setting display mode, referring to page 6. A window opens and a setting items table is displayed.
- ② Select a desired item to be set by moving the cursor by means of ◀ • ▶ • ▲ • ▼ keys.
- ③ Select COMP.
- ④ Press Enter key to enter the setting table display (12 points collective) screen.
- ⑤ For stopping the setting, press Esc key. The screen returns to the last one, each time Esc key is pressed once.
- ⑥ Move the cursor to a desired channel number to be set by ▲ or ▼ key.

The cursor does not move to any item other than CH. No.

RECORD ON		100mm/h				2006/06/14 10:33:28			
CH.	ON/OFF	S1		S2		S3		S4	
		Pos.(%)	Span	Pos.(%)	Span	Pos.(%)	Span	Pos.(%)	Span
001	OFF								
002	OFF								
003	OFF								
004	OFF								
005	OFF								
006	OFF								
007	OFF								
008	OFF								
009	OFF								
010	OFF								
011	OFF								
012	OFF								

[ESC] : Close [Enter] : Setting [Func2] : Copy

- ⑦ After selecting a channel to be set, press Enter key. A window opens and a setting parameter entry screen is displayed. (For the setting parameter entry screen, refer to ⑧)
- ⑧ Move the cursor to a desired channel number to be set by ◀ • ▶ • ▲ • ▼ keys.

Spread Record		CH001	
Spread Recording	ON	▼	
S1 Pos. (%)	<input type="text"/>	S1 Span	<input type="text"/>
S2 Pos. (%)	<input type="text"/>	S2 Span	<input type="text"/>
S3 Pos. (%)	<input type="text"/>	S3 Span	<input type="text"/>
S4 Pos. (%)	<input type="text"/>	S4 Span	<input type="text"/>
			[Set]

Each time Enter key is pressed once, the cursor move in the sequence of Spread Recording → S1 Pos.(%) → S1 Span → S2 Pos.(%) → S2 Span → S3 Pos.(%) → S3 Span → S4 Pos.(%) → S4 Span → Set. The Spread Recording parameter input area is determined by selecting a setting parameter. A window opens. Select a parameter by ▲ or ▼ key.

After setting this screen, bring the cursor to [Set] .

- ⑨ Terminate the setting (change, addition) by pressing Enter key.
- ⑩ For copying a set value, press [Func 2] key in the screen in ⑥. Input the copy source and copy destination by numeric keys. After the end of setting, bring the cursor to [Copy] and press [Enter] key.

13-3-3. Parallel scale recording

- The analog recording range is divided into maximum 5 areas and set values can be divided into groups and recorded.
- For the number of areas and each recording range, refer to the following figure. Both ends of each area are the minimum and maximum values of the range setting analog recording range.

Analog recording rang	0mm	250mm			
No. of areas 2	No.1 0~112.5	No.2 137.5~250			
No. of areas 3	No.1 0~75	No.2 87.5~162.5	No.3 175~250		
No. of areas 4	No.1 0~50	No.2 62.5~112.5	No.3 137.5~187.5	No.4 200~250	
No. of areas 5	No.1 0~40	No.2 52.5~92.5	No.3 105~145	No.4 157.5~197.5	No.5 210~250

【Setting method】*Set the following setting after checking if the [PARALLEL] is selected on analog recording format (p13-6).

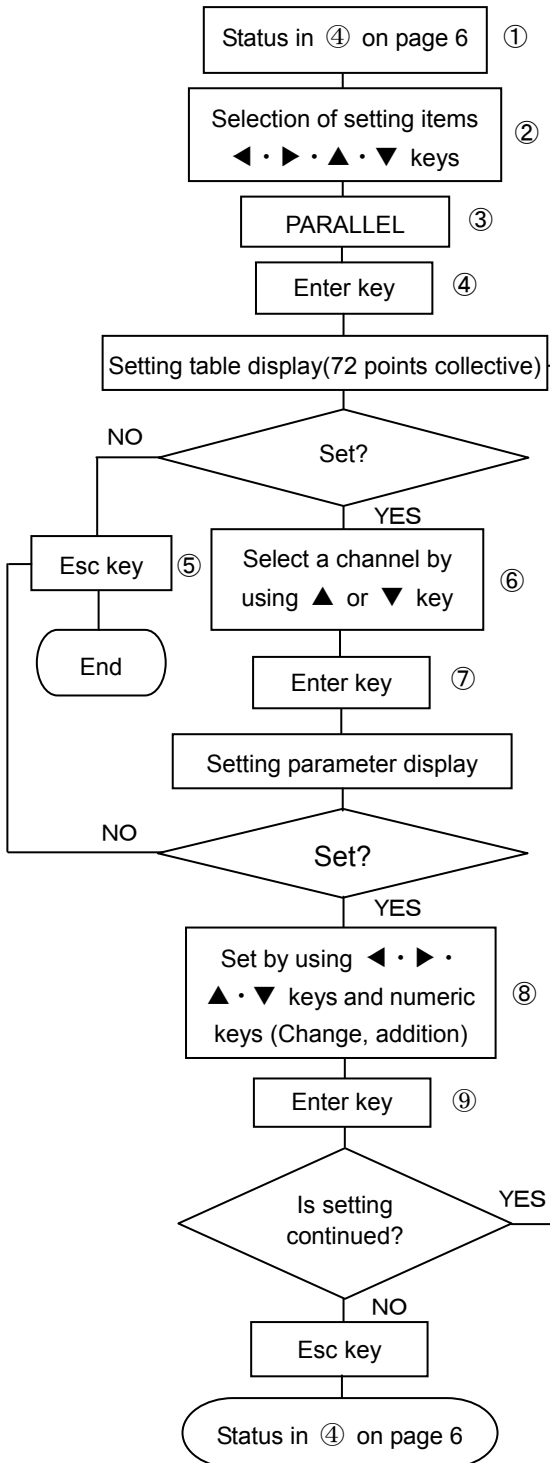

- ① Select OPT.MENU to enter the setting display mode, referring to page 6. A window opens and a setting items table is displayed.
- ② Select a desired item to be set by moving the cursor by means of ◀ • ▶ • ▲ • ▼ keys.
- ③ Select PARALLEL.
- ④ Press Enter key to enter the setting table display (72 points collective) screen.
- (For the setting table display (72 points collective) screen, refer to ⑥)
- ⑤ For stopping the setting, press Esc key. The screen returns to the last one, each time Esc key is pressed once.
- ⑥ Move the cursor to a desired channel number to be set by ▲ or ▼ key. The cursor does not move to any item other than CH. No.

RECORD ON												100mm/h	2006/06/14 10:33:28	
Dot No.	Area No.	Dot No.	Area No.	Dot No.	Area No.	Dot No.	Area No.	Dot No.	Area No.	Dot No.	Area No.	Area Number		
01	1	13	1	25	1	37	1	49	1	61	1	1		
02	1	14	1	26	1	38	1	50	1	62	1			
03	1	15	1	27	1	39	1	51	1	63	1			
04	1	16	1	28	1	40	1	52	1	64	1			
05	1	17	1	29	1	41	1	53	1	65	1			
06	1	18	1	30	1	42	1	54	1	66	1			
07	1	19	1	31	1	43	1	55	1	67	1			
08	1	20	1	32	1	44	1	56	1	68	1			
09	1	21	1	33	1	45	1	57	1	69	1			
10	1	22	1	34	1	46	1	58	1	70	1			
11	1	23	1	35	1	47	1	59	1	71	1			
12	1	24	1	36	1	48	1	60	1	72	1			

ESC : Close Enter : Setting Func1 : Area Num. Func2 : Copy

- ⑦ After selecting a channel to be set, press Enter key. A window opens and a setting parameter entry screen is displayed. (For the setting parameter entry screen, refer to ⑧)
- ⑧ Move the cursor to a desired channel number to be set by ◀ • ▶ • ▲ • ▼ keys. After pressing Enter key, select No. of areas by using ▲ or ▼ key. After the end of setting in this screen, bring the cursor to [Set].
- ⑨ Terminate the setting (change, addition) by pressing Enter key.
- ⑩ For the number of divisions of areas, press [Func1] key in the screen in ⑥. The left screen is displayed. After pressing Enter key, select the number of areas divisions by ▲ or ▼ key. After setting this screen, bring the cursor to [Set].
- ⑪ Terminate the setting (change, addition) by pressing Enter key.
- ⑫ For copying a set value, press [Func 2] key in the screen in ⑥. Input the copy source and copy destination by numeric keys. After the end of setting, bring the cursor to [Copy] and press [Enter] key.

(Note1)

If area No. exceeding the division area number or no area No. is set, analog recording is not done.

13-4. Rate-of-change alarm/Differential alarm

13-4-1. Rate-of-change alarm

- When dt changes width (refer to below) and increases or decreases from the predicted measuring data, and is over the alarm setting value, alarm occurs.
- Rate-of-change alarm has two kinds of alarms, which are increase limit and decrease limit. Both limits alert when change width of dt is over the setting value.
- Range of dt setting is within 0.1 second to 1800.0 second and set optional time by 0.1 second.
- Interval of alarm determination is 0.1 minute, rate-of-change alarm needs previous data. Recordable data is up to 20. When setting dt more than 2 second, calculated value of below is interval time of alarm determination.

$$\frac{\left\{ \frac{dt(\text{second}) \times 10 - 1}{2} \right\} + 1}{10} = \text{Interval}$$

※Calculation is all integer calculation.

- Setting number of alarm is up to 4 level by 1 channel.
- Alarm kinds can be set optionally in conjunction with higher limit, lower limit (standard), differential higher limit, and differential lower limit.

【Setting method】

- 1) Refer to setting of alarm and set it.
(I . Instruction manual 8-6. 「ALARM」)
- 2) Select [U] or [D] for kind.
- 3) dt (second) is set optional time which is range 0.1 second to 1800.0 second by 0.1 second with using numeric keys.
- 4) Refer to following figure for screen of setting list display (collective 12 point).

RECORD ON		20mm/h		ALARM CH001		2005/06/03 15:25:30	
CH.	1st level						
	Kind	Relay	Mode	Set value	Dead band	Di.Ch	dt(sec)
001							
002							
003							
004							
005							
006							
007							
008							
009							
010							
011							
012							

Esc :Close Enter :ALARM set Func1 :Level Func2 :Copy CONST

Display 12 point correctively; however display of level is only first level.
Select [Func1] key for switching next level.
Displayed level is switched every clicking the key.

- 5) Refer to following figure for display of setting parameter recording.

Alarm		CH001	
Level	<input type="text"/>	▼	
Kind	<input type="text"/>	▼	
Relay No.	<input type="text"/>	And/Or	<input type="text"/> ▼
Set value	<input type="text"/>	Dead band	<input type="text"/>
Diff.CH	<input type="text"/>	dt(sec)	<input type="text"/>
Set			

A window opens and select type of alarm using ▲ · ▼ keys. Refer to below.

None	
H	Higher limit alarm
L	Lower limit alarm
U	Rate-of-change increase-limit alarm
D	Rate-of-change decrease-limit alarm
B	Differential higher-limit alarm
S	Differential lower-limit alarm

【Note 1】

The cursor dose not move to parameter input area of unnecessary setting depending on set alarm type.

13-4-2. Differential alarm

- When input difference (absolute value) of 2 channel is over the alarm setting value, alarm will occur.
- Differential alarm has differential higher-limit alarm and differential lower-limit alarm. In differential higher-limit, alarm occurs when difference of input is bigger than alarm setting value. In differential lower-limit, alarm occurs when difference of input is less than alarm setting value.
- Setting number of alarm is up to 4 level by 1 channel. Alarm kinds can be set optionally in conjunction with higher limit, lower limit (standard), differential higher limit, and differential lower limit.

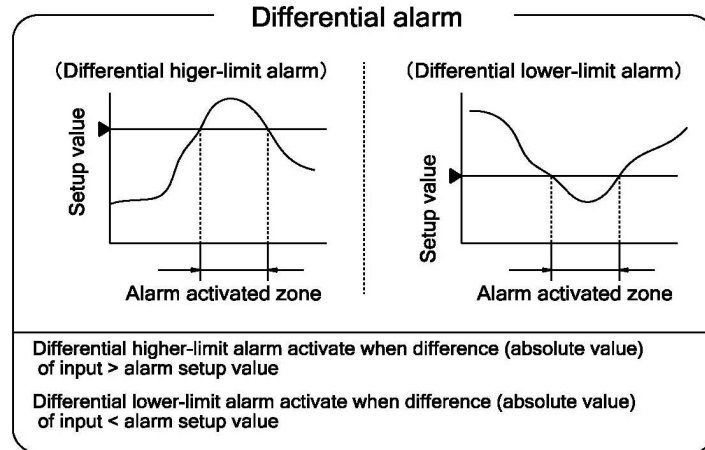

【Setting method】

- 1) Refer to setting of alarm and set it. (I . Instruction manual 8-6. 「ALARM」)
- 2) Select [B] or [S] for kind.
- 3) Input channel for calculating input difference in differential. Channel is 1 through 72.
- 4) Refer to following figure for screen of setting list display (collective 12 point)

RECORD ON		20mm/h		ALARM CH001		2005/06/03 15:25:30	
CH.	Kind	Relay	Mode	Set value	Dead band	Di.Ch	dt(sec)
001							
002							
003							
004							
005							
006							
007							
008							
009							
010							
011							
012							

Esc : Close Enter : ALARM set Func1 : Level Func2 : Copy CONST

Display 12 point correctively; however display of level is only first level. Select [Func1] key for switching next level. Displayed level is switched every clicking the key.

- 5) Refer to following figure for display of setting parameter recording.

Alarm		CH001	
Level	<input type="text"/>	▼	
Kind	<input type="text"/>	▼	
Relay No.	<input type="text"/>	And/Or	<input type="text"/> ▼
Set value	<input type="text"/>	Dead band	<input type="text"/>
Diff.CH	<input type="text"/>	dt(sec)	<input type="text"/>
<input type="button" value="Set"/>			

A window opens and select type of alarm using ▲ · ▼ keys. Refer to below..

None	
H	Higher-limit alarm
L	Lower-limit alarm
U	Rate-of-change increase-limit alarm
D	Rate-of change decrease-limit alarm
B	Differential higher-limit alarm
S	Differential lower-limit alarm

【Note 1】

The cursor dose not move to parameter input area of unnecessary setting depending on set alarm type.

13-5. Operation

Function of recording operation between several channel or operation results of time series of specific channel to specified channel.

Data of operation of output channel is performed analog recording/digital recording/data display like data of general input intake, and also performed recording format/skip specified.

【Operation type】	
●Inter-channel	: Maximum, Minimum, Average, Sum
●Time series	: Maximum, Minimum, Average, Totalizing (1 minute to 24 hours)
●Operation formula	: Operation by prepared function formula
【Output channel of operation】	
CH. No. 37-72	

【Setting of output channel of operation】

Setting parameter of input after CH037 is selected from [Unused]/[Operation]. When using for output channel of operation, selecting [operation].

Channel parameter for operation output channel can be copied.

Refer to (I . Instruction manual: 6-16, 8-17) for detail.

【Setting method】

1. Differential operation

1) Refer to setting of differential recording and set it. (I . Instruction manual 8-7. 「CALC. 」)

2) Select [SUB] or [SUI] for kind.

3) Refer to following figure for screen of setting list display (collective 12 point).

Unrelated items for type which is set in operation output channel is not display.

RECORD ON		100mm/h		2005/06/14 10:33:28					
Ch.	Kind	SUB/SUI			MIN/MAX/AVE/SUM		TMIN/TMAX/TAVE/TSUM		Result D.P.
		Ch.	Ch.	Const.C	Ch.	Ch.	Start	Interval	
CH037									
CH038									
CH039									
CH040									
CH041									
CH042									
CH043									
CH044									
CH045									
CH046									
CH047									
CH048									
[ESC] :Close		[Enter] :Operation			[Func2] :Copy				

4) Refer to following figure for display of setting parameter recording.

The cursor does not move to parameter input area of unnecessary setting depending on set operation type.

Calculation CH037			
Kind	None ▼	Decimal point	<input type="text"/>
Dif.calc.			
X CH	<input type="text"/>	Const. C	<input type="text"/>
Ch. to Ch.			
CH	None ▼	None ▼	<input type="text"/>
Time ser.			
CH	<input type="text"/>	Start	<input type="text"/> : <input type="text"/>
		Interval	<input type="text"/> : <input type="text"/>
[Set]			

Select one from following for operation type of differential recording.

SUB	Inter-CH differential recording : X-Y
SUI	Standard value differential recording : X-C

2. Inter-channel

- 1) Refer to setting of differential recording and set it. (I . Instruction manual 8—7. 「CALC. 」)
- 2) Select [MIN], [MAX], [AVE], or [SUM] for kind.
- 3) Refer to previous page [1. Differential operation] for screen of setting list display (collective 12 point)
Unrelated items for type which is set in operation output channel is not displayed.
- 4) Refer to previous page [1. Differential operation] for display of setting parameter recording.
The cursor dose not move to parameter input area of unnecessary setting depending on set operation type.

Select one from following for operation type of inter-channel.

MIN	Inter-CH minimum value
MAX	Inter-CH maximum value
AVE	Inter-CH average value
SUM	Inter-CH sum value CH

- 5) Refer to below for selecting of inter-channel.
 - ①[None]: Only 1channel is selected.
 - ②[/]: 2 channels which are channel ○○ and channel ○○ are selected.
 - ③[~]: Several channels which are from channel ○○ to channel ○○ are selected.

【Example】

When select 9 channels which are channel 1,2,3,4,5,6,7,8, and 12, setting like below.

3. Time series

- 1) Refer to setting of differential recording and set it. (I . Instruction manual 8—7. 「CALC. 」)
- 2) Select [TMIN], [TMAX], [TAVE], or [TSUM] for kind.
- 3) Refer to previous page [1. Differential operation] for screen of setting list display (collective 12 point)
Unrelated items for type which is set in operation output channel is not display.
- 4) Refer to previous page [1. Differential operation] for display of setting parameter recording.
The cursor dose not move to parameter input area of unnecessary setting depending on set operation type.

Select one from following for operation type of time series.

TMIN	Minimum value every interval
TMAX	Maximum value every interval
TAVE	Average value every interval
TSUM	Totalizing value every interval

- 5) Refer to following for start time and interval.
 - ①Setting of start time is from to and optional setting by every 1 minute.
 - ②Setting of interval is from to and optional setting by every 1 minute.

- (Note 1)** When input type of operation output channel is [unused], do not record and display even if detail setting of operation is done.
- (Note 2)** In case of minimum value operation, when there are [under flow]/[under range] in the data which is specified channel, minimum value is [under flow] or [under range]. However, when returned to normal data, error data is deleted from operation data. (same as maximum vale and average value operation).
- (Note 3)** In case of time series operation, not recording before set start time.
- (Note 4)** When there are error data such as [over], [under], and [burnout] in time series operation, do like (Note 2).
- (Note 5)** When power is off after set start time in time series operation, data during that time is deleted from operation result.

4. Operation formula

- 1) Refer to setting of differential recording and set it. (I . Instruction manual 8-7. 「CALC. 」)
- 2) Select [EXT] for kind.
- 3) Refer to previous page [1. Differential operation] for screen of setting list display (collective 12 point)
Unrelated items for type which is set in operation output channel is not display.
- 4) Refer to previous page [1. Differential operation] for display of setting parameter recording.
The cursor dose not move to parameter input area of unnecessary setting depending on set operation type.

Select EXT (operation formula) for operation type of operation formula.

- ① After selecting EXT (operation formula), press ENTER key. Following screen is shown, and then create operation formula.

- ② Press Enter key when cursor is on the [operation formula], and create formula.

Refer to guidance of lower the screen for create formula. When press the [Func1] key, can read standard formula like figure 1.

Figure 1

CH(PCH(OCH(ITG(FV(RH(DEW(
AND	OR	XOR	NOT(CEL(FLR(ABS(SQR(EXP(LOG(LOG10(
<<	>>	<=	>=	==	!=					

- ③ After end of creating operation formula, bring the cursor to **SET** and press [Enter] key.

4-1. Computation types

4-4-1. Mathematical calculation Four arithmetic operations are performed.

	Symbol	Example	Remarks
Totalizer	+	X + Y	
Subtraction	-	X - Y	
Multiplication	*	X * Y	
Division	/	X / Y	
Reminder	%	X % Y	
Exponential	^	X ^ Y	

※X and Y indicate the formula or the numeric value

4-4-2. Comparison calculation The comparison calculation is performed and the result is;1 (established) or 0 (not established).

	Symbol	Example	Remarks
Equal value	==	X == Y	
Unequal value	!=	X != Y	
More than	>>	X >> Y	
Less than	<<	X << Y	
Equal or more than	>=	X >= Y	
Equal or less than	<=	X <= Y	

※X and Y indicate the formula or the numeric value.

4-4-3. Logical operation The logical operation for 1 or 0 is performed and the result is returned as 1 or 0.

	Symbol	Example	Remarks
Logical AND	AND	X AND Y	
Logical OR	OR	X OR Y	
Exclusive OR	XOR	X XOR Y	
Negation	NOT	NOT(X)	

※X and Y indicate the formula or the numeric value. Express X and Y as 0 or 1.

4-4-4. General calculation function The function calculation is performed.

	Symbol	Example	Remarks
Round up after the decimal	CEL	CEL(X)	
Round down after the decimal	FLR	FLR(X)	
Absolute value	ABS	ABS(X)	
Square root	SQR	SQR(X)	
Power of e	EXP	EXP(X)	
Natural logarithm (The base is e)	LOG	LOG(X)	
Common logarithm (The bottom is 10)	LOG10	LOG10(X)	

※X indicates the formula or the numeric value.

4-4-5. Channel data calculation function The function calculation is performed. When error data (OVER, UNDER etc.) is included in the measured data, it becomes "CAL ER".

	Symbol	Example	Remarks
Measured data	CH	CH(X)	X is channel No.
Calculated result data	PCH	PCH(X)	
Previous calculated result data	OCH	OCH(X)	Data at the previous scanning
Totalizer	ITG	ITG(X)	Refer to 1) Totalizer operation
F-value	FV	FV(X#To#Z#R)	Refer to 2) F-value
Relative humidity	RH	RH(D#W)	Refer to 3) Relative humidity
Dew-point temperature	DEW	DEW(T#H)	Refer to 4) Dew-point temperature

※X indicate the channel number.

※When the channel data calculation is specified for executing with the settings of the designated channel number, the calculated results of the designated channel number are used. In addition, when the designated channel number is greater than the channel number for calculation, the calculation results obtained previously at the designated channel are used.

1) Totalizer operation

For the totalizer, the ITG function or the ITG24 function is used.

Do not use the totalizing function more than two times in one formula. The results are not calculated correctly.

The totalizing function can be used in calculations other than the totalizer.

Example ~~ITG(1)+ITG(2)~~, ~~ITG24(1)+ITG(1)~~, ITG(1)/100

For the totalizer reset, refer to chapter 13.6.

1. Standard totalizing operation

The totaled values are reset at the totalizer reset reference time and every interval.

Entering method of the formula

ITG(d)

d: Channel number to be totalized

Calculation contents

$$D_n = D_{n-1} + \{(PV_n + PV_{n-1}) \times (T_n - T_{n-1})\} \div 2$$

D_n : Totalizing result D_{n-1} : Previous totalized result

PV_n : Data to be totalized PV_{n-1} : Data totalized at the previous calculation

T_n : Time of calculation T_{n-1} : Time of the previous calculation (before 0.1 seconds)

When error data (OVER, UNDER etc.) is included, the calculation is not performed and previous results are used.

2. 24-hour totalizing operation

The totaled values are reset only at totalizer reset reference time.

Entering method of the formula

ITG24(d)

d: Channel number to be totalized

The calculation contents are same as the standard totalizing operation.

2) F-value

Entering method of the formula

FV(X#To#Z#R)

X: Channel to be calculated, To: F-value calculation reference temperature, Z: Z-value,

R: F-value calculation starting temperature

The following formula is used for the F-value calculation

$\int 10^{A dt}$ Provision: $A=(T-To) \div Z$ T: Channel data to be calculated

When T exceeds R, F-value is reset to 0.

3) Relative humidity

Entering method of the formula

RH(D#W)

D: Dry bulb temperature, W: Wet bulb temperature

The following formula is used for the relative humidity calculation

$((B - 0.000662 \times 1013.0 \times (D - W)) \div A) \times 100$

Provision: A: Dry bulb saturated water vapor pressure, B: Wet bulb saturated water vapor pressure

The following formula is used for the calculation of the saturated water vapor pressure.

$6.1121 \times \text{EXP}((17.502 \times T) \div (240.9 + T))$ T: Temperature

4) Dew-point temperature

Entering method of the formula

DEW(T#H)

T: Temperature data channel, H: Relative humidity channel

The following formula is used for the dew-point temperature

t: Temperature data

h: Relative humidity data

D: Dew-point temperature

① $K=t+273.15$ $K=t+273.15$

② In case of $t \geq 0$ $t \geq 0$

$$W = \text{EXP}(-5800.2206 / K + 1.3914993 + K \times (-0.048640239 + K \times (0.41764768E-4 - 0.14452093E-7 \times K))) + 6.5459673 \times \text{LOG}(K) / 1000$$

In case of $t < 0$

$$W = \text{EXP}(-5674.5359 / K + 6.3925247 + K \times (-9.677843E-3 + K \times (0.62215701E-6 + K \times (0.20747825E-8 - 9.484024E-13 \times K)))) + 4.1635019 \times \text{LOG}(K) / 1000$$

③ $S=W \times h / 100$

④ $P=S \times 1000$

⑤ $Y=\text{LOG}(P)$

⑥ In case of $P \geq 611.2$

$$D = -77.199 + Y \times (13.198 + Y \times (-0.63772 + 0.071098 \times Y))$$

In case of $P < 611.2$

$$D = -60.662 + Y \times (7.4624 + Y \times (0.20594 + 0.016321 \times Y))$$

MEMO

CHINO

CHINO CORPORATION

32-8, KUMANO-CHO, ITABASHI-KU, TOKYO 173-8632

Telephone: 81-3-3956-2171

Facsimile: 81-3-3956-0915

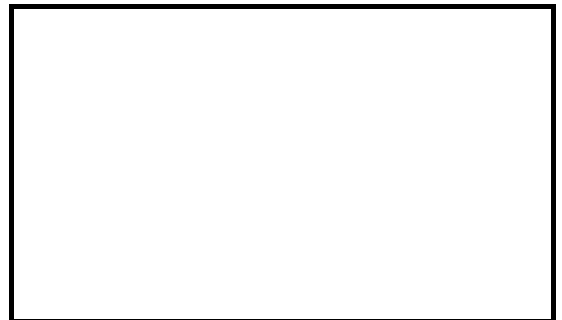

Printed in Japan ()