

Model C-RL

Ultrasonic Flow Transducer

Instruction Manual



Flow



Model C-RL

Ultrasonic Flow Transducer

Installation Guide

916-062 B
July 2021

panametrics.com

Copyright 2021 Baker Hughes company.

This material contains one or more registered trademarks of Baker Hughes Company and its subsidiaries in one or more countries. All third-party product and company names are trademarks of their respective holders.

[no content intended for this page]

Information Paragraphs

Note: These paragraphs provide information that provides a deeper understanding of the situation, but is not essential to the proper completion of the instructions.

IMPORTANT: These paragraphs provide information that emphasizes instructions that are essential to proper setup of the equipment. Failure to follow these instructions carefully may cause unreliable performance.



CAUTION! This symbol indicates a risk of potential minor personal injury and/or severe damage to the equipment, unless these instructions are followed carefully.



WARNING! This symbol indicates a risk of potential serious personal injury, unless these instructions are followed carefully.

Safety Issues



WARNING! It is the responsibility of the user to make sure all local, county, state and national codes, regulations, rules and laws related to safety and safe operating conditions are met for each installation.



WARNING! For installations in potentially hazardous areas, be sure to read the *Certification and Safety Statements* document at the end of this manual before beginning the installation.

Auxiliary Equipment

Local Safety Standards

The user must make sure that he operates all auxiliary equipment in accordance with local codes, standards, regulations, or laws applicable to safety.

Working Area



WARNING! Auxiliary equipment may have both manual and automatic modes of operation. As equipment can move suddenly and without warning, do not enter the work cell of this equipment during automatic operation, and do not enter the work envelope of this equipment during manual operation. If you do, serious injury can result.



WARNING! Make sure that power to the auxiliary equipment is turned OFF and locked out before you perform maintenance procedures on the equipment.

Qualification of Personnel

Make sure that all personnel have manufacturer-approved training applicable to the auxiliary equipment.

Personal Safety Equipment

Make sure that operators and maintenance personnel have all safety equipment applicable to the auxiliary equipment. Examples include safety glasses, protective headgear, safety shoes, etc.

Unauthorized Operation

Make sure that unauthorized personnel cannot gain access to the operation of the equipment.

Environmental Compliance

Waste Electrical and Electronic Equipment (WEEE) Directive

GE Measurement & Control is an active participant in Europe's *Waste Electrical and Electronic Equipment (WEEE)* take-back initiative, directive 2012/19/EU.

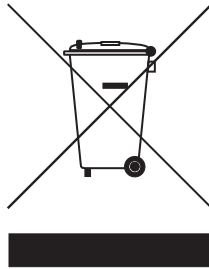

The equipment that you bought has required the extraction and use of natural resources for its production. It may contain hazardous substances that could impact health and the environment.

In order to avoid the dissemination of those substances in our environment and to diminish the pressure on the natural resources, we encourage you to use the appropriate take-back systems. Those systems will reuse or recycle most of the materials of your end life equipment in a sound way.

The crossed-out wheeled bin symbol invites you to use those systems.

If you need more information on the collection, reuse and recycling systems, please contact your local or regional waste administration.

Visit www.bakerhughesds.com/health-safetyand-environment-hse for take-back instructions and more information about this initiative.

1	Introduction	1
2	Transducer Construction	1
3	Dampening Material.....	2
4	Installing the C-RL Transducers.....	3
	4.1 Choosing an Installation Location	5
	4.2 Obtaining the Transducer Spacing.....	6
	4.3 Installing the V Series Clamping Fixtures and Transducers.....	6
	4.4 What's Next?	21
	4.5 Installing the PI Fixture and Transducers	22
	4.6 What's Next?	39
	4.7 Maintenance.....	40
	4.8 Transducer Specifications	41

1 Introduction

The C-RL clamp-on ultrasonic flow transducers are used exclusively with the Panametrics Measurement & Control line of ultrasonic flowmeters. These transducers are used to measure the flow of various gases through pipes having diameters from 3/4 in. (20 mm) to 30 in. (750 mm). Such measurements are independent of the pipe material. This manual provides details on the following topics:

- Transducer construction
- Dampening material
- Installation
- Maintenance
- Specifications

2 Transducer Construction

A transducer assembly includes a 316 stainless steel housing with a plastic wedge attached and a BNC-type electrical connector. The transducer features both integral 3/4" NPT-M threads for mounting a junction box and integral 5/8-24 UNEF threads for mounting a submersible connector if desired (see *Figure 1* below).

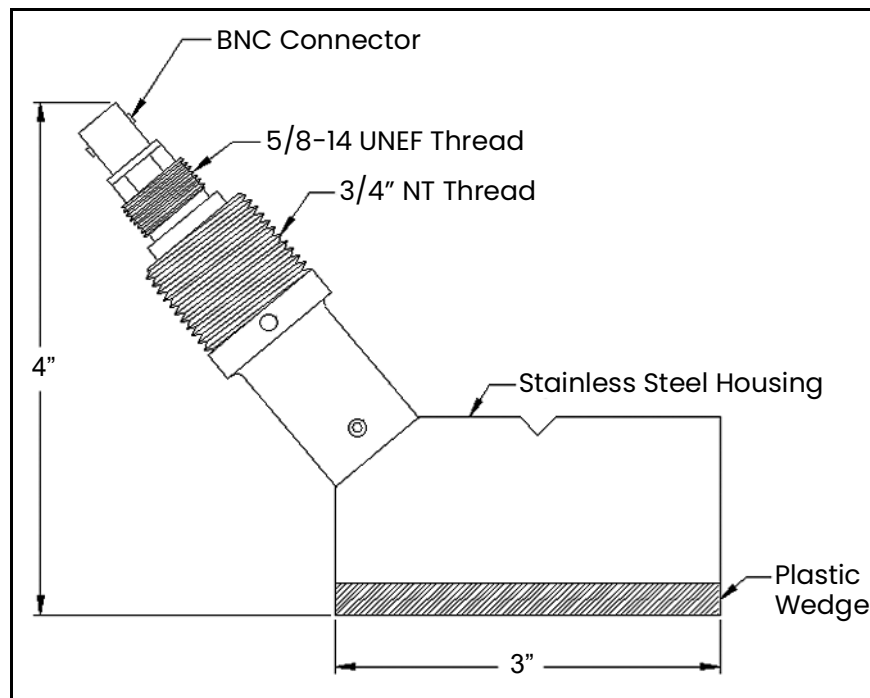

Figure 1: Transducer Assembly (Ref. dwg. 752-163)

3 Dampening Material

Panametrix Measurement & Control strongly recommends applying **DMP** dampening material in all permanent clamp-on applications to help eliminate noise. The following dampening materials are available:

- **DMP-1** is a self-adhesive sheet for applications up to 200°F (93°C): The material comes as two 9.5-in. (24 cm) wide sheets cut in sufficient length for your application. (Length \approx twice the circumference of the pipe at the installation site.)
- **DMP-3** is a compound for applications over 150°F (65°C). The compound is applied to the pipe with a putty knife.
- The *Pipe Dampening Jacket (PDJ)* is a sheath/jacket with **DMP-3** pre-applied to the inside and is also used for applications over 150°F (65°C). The **PDJ** is available for pipes 4", 6", 8", 10" and 12" (100, 150, 200, 250 and 300 mm) in diameter.

At a minimum, you should consider applying dampening material if you have any of the following conditions:

- The distance from the nearest butt weld or pipe flange is less than 10 ft (3 m).
- The pipe size is under 16 in. (400 mm) diameter and the gas pressure is 200 psig (1378 kPa) or lower.
- The pipe is deformed (non-circular).
- The pipe is old, with a history of scaling or rust.
- The pipe experiences constant condensation on the outside.

Note: *Consult a Panametrix flowmeter applications engineer or sales engineer if you have any questions regarding dampening material.*

Details for properly installing the dampening material are discussed later in this manual.

4 Installing the C-RL Transducers

Panametrics Measurement & Control offers the following transducer mounting fixtures to suit your applications needs:

- V1 clamping fixture
- V4 clamping fixture
- V8 clamping fixture
- V12 clamping fixture
- PI clamping fixture

Figure 2 below and *Figure 3 on page 4* show the V1, V4, V8, V12 and PI fixture assemblies. Each type of transducer and fixture requires the installation of dampening material for acoustic isolation.

Complete the steps in the following sections to position and install the transducers, fixtures and dampening material.

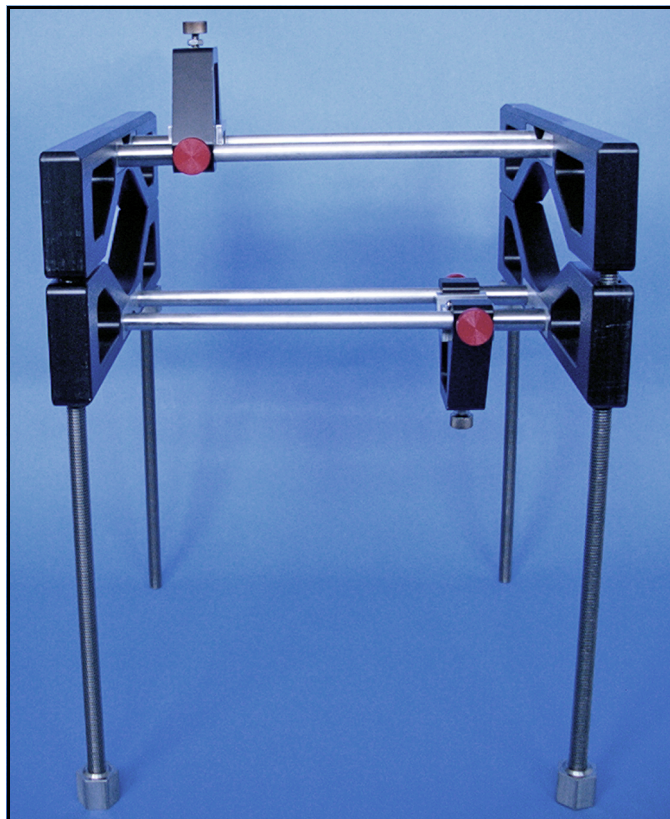

Figure 2: The V12 Mounting Fixture

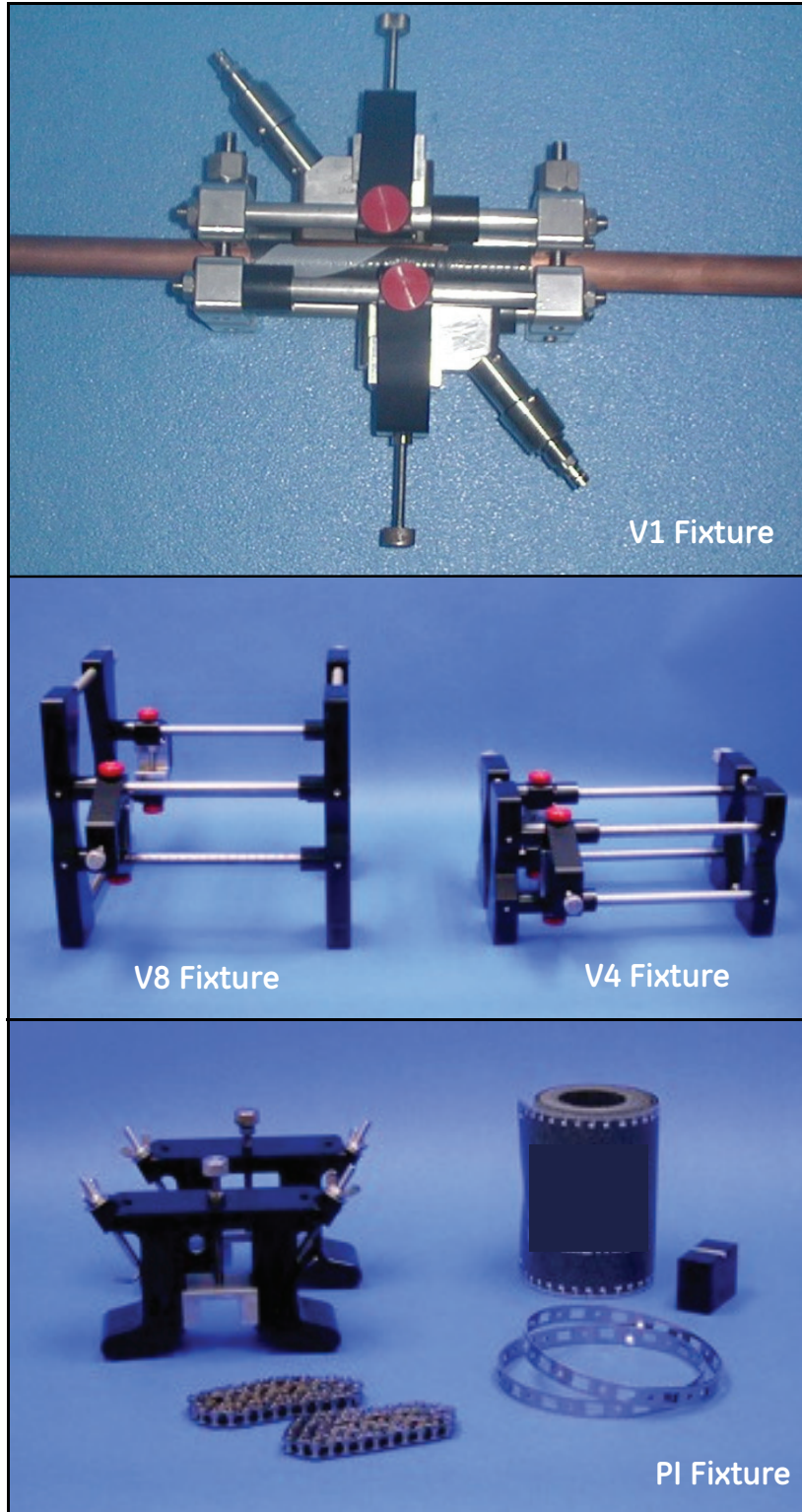

Figure 3: The V1, V4, V8 and PI Mounting Fixtures

4.1 Choosing an Installation Location

To choose an installation location, proceed as follows:

1. Locate the transducer measurement point at least 3 ft (1 m) from any butt welds or flanges, ideally in the center of a 20 ft (6 m) length of straight pipe. Keep appropriate clearance on either side of the pipe for easy transducer installation access:
 - 6 in. (15 cm) if you are not using a junction box, or
 - 9 in. (23 cm) if you are using a junction box.

Note: *To guarantee the specified accuracy of the flowmeter there is no substitute for a straight length of pipe and a fully-developed flow profile. However, if a straight length of pipe is not available, the transducer location should be in a position such that the acoustic signal travels through the full distribution of the under-developed flow profile for best repeatability.*

2. Place the transducers as close as possible to the horizontal plane. Locate the transducers on opposite sides of the pipe 180° apart, ideally at the 3 and 9 o'clock positions.

IMPORTANT: Do not locate the transducers on the top or the bottom of the pipe.

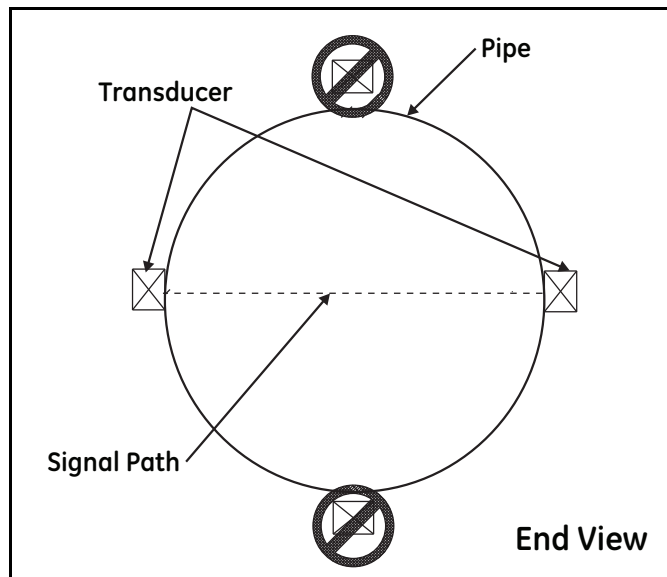

4.2 Obtaining the Transducer Spacing

Program the required information into the **Pipe Parameters** menu of the flowmeter *User Program* to determine the required transducer spacing. Some applications may require you to conduct a pipe survey before you can obtain the transducer spacing. Refer to the flowmeter *Startup Guide* for more details.

Proceed to the appropriate section to install the transducers and fixtures:

- “Installing the V Series Clamping Fixtures and Transducers” on page 6.
- “Installing the PI Fixture and Transducers” on page 22



CAUTION! To maintain ATEX certification, the transducer face must be protected against impact. This is accomplished by properly installing the transducer into the clamping fixture. All care must be taken during installation to ensure that the proper protection is provided.

4.3 Installing the V Series Clamping Fixtures and Transducers

Installing the V Series clamping fixture and transducers requires the following steps:

- Calculating the transducer spacing
- Preparing the pipe
- Applying the dampening material
- Installing the fixture
- Mounting the transducers

Refer to the following section to properly prepare for installation

4.3.1 Tools and Equipment Needed

Installing the fixture and transducers requires various tools. You will also need additional tools to apply the dampening material. Refer to *Table 1* below for a complete list of everything you will need.

Fixture and Transducers		
<ul style="list-style-type: none">• straight edge ruler/scale• permanent marker• sandpaper• file• emery cloth• ultrasonic thickness gage• tape measure• dry towel or rag• thread sealant (for junction boxes only)• 7/16" box wrench or 4" adjustable wrench• 1" box wrench or 10" adjustable wrench• other safety equipment appropriate for your application		
DMP-1	DMP-3	PDJ
<ul style="list-style-type: none">• utility knife	<ul style="list-style-type: none">• gloves• spatula or putty knife (to remove access dampening compound)	<ul style="list-style-type: none">• 7/16" box wrench or a 4" adjustable wrench

4.3.2 Setting the Transducer Spacing

1. If necessary, assemble the fixture as shown below. Make sure the zero points on each ruler are at the same end of the fixture.

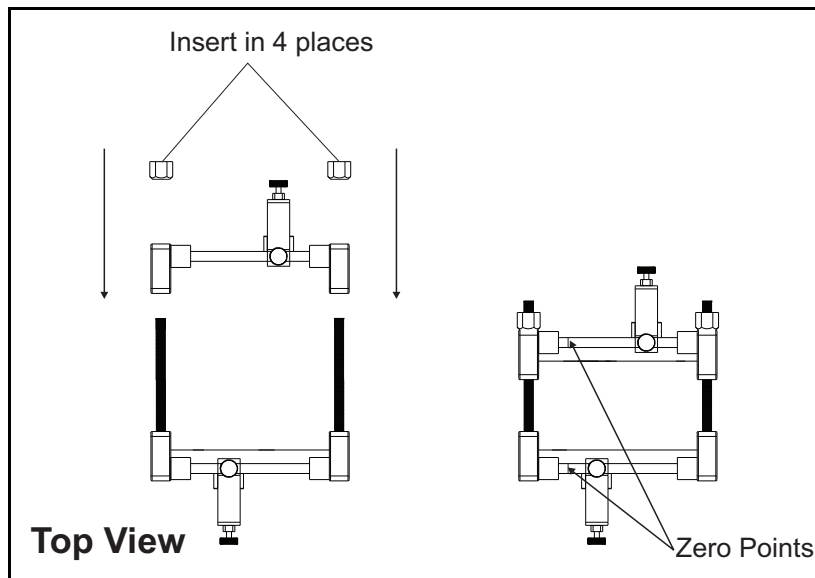

2. Using a ruler (or the ruler printed on the fixture), set one of the mounting blocks at least 1 in. (2.5 cm) from the edge of the fixture. To move the block, loosen the set screw, slide the block to the desired location and tighten the set screw. Use the edge of the block shown below as the setting point.

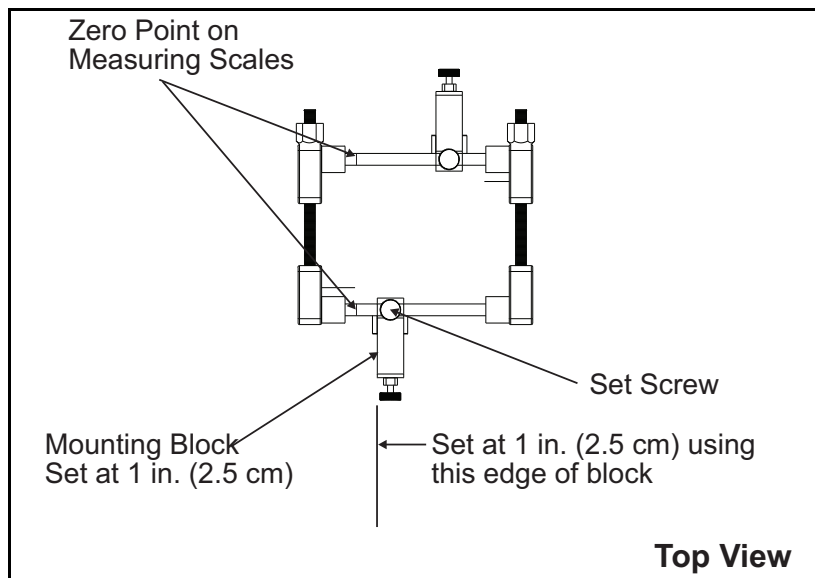

3. Slide the other mounting block to the calculated spacing *plus* 1 in. (2.5 cm). For example:

- a. Spacing for the first mounting block = 1 in. (2.5 cm)
- b. Spacing as calculated by the flowmeter = 0.5 in. (12.5 mm)
- c. Second mounting block final location = 1 in. + 0.5 in. = 1.5 in. (2.5 cm + 1.25 cm = 3.75 cm)

The overall spacing between blocks should be either left edge to left edge or right edge to right edge.

Note: *If possible, the second block should also be set at least 1 in.(2.5 cm) from the edge of the fixture.*

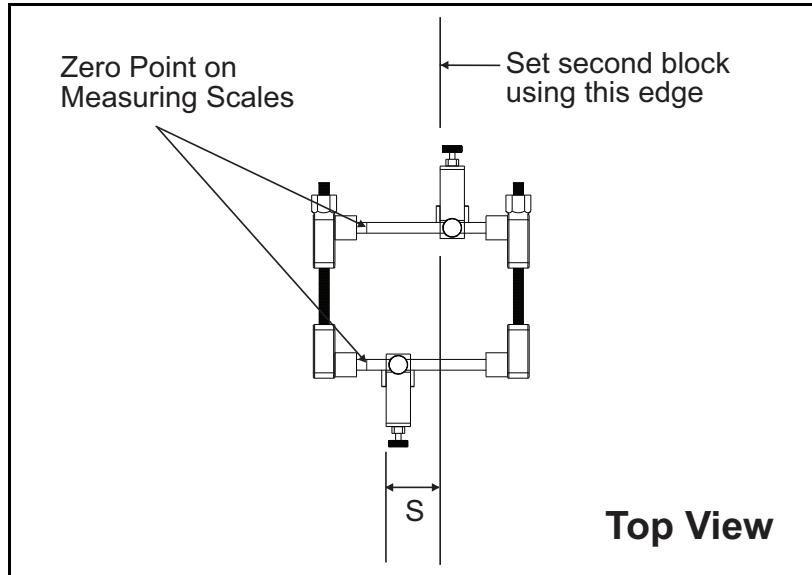

4.3.3 Installing the Fixture

During this procedure you will be required to place the fixture and transducers on the pipe more than once, and in some cases, as many as 3 times. The fixture and transducers are placed on the pipe temporarily for two purposes:

- To mark where the fixture and transducers make contact with the pipe so those sections can be cleaned
- As a reference for placing the dampening material

Use the steps below to begin installation:

1. Remove any pipe insulation from the installation site.

Note: Make sure you clear an area that is large enough for the transducers and dampening material installation.

2. Disassemble the fixture by removing the four nuts from the threaded rods and pulling apart the two halves of the fixture.

Note: Make note of the assembled fixture to make sure you reassemble it the same way. Otherwise, the transducer spacing will be incorrect.

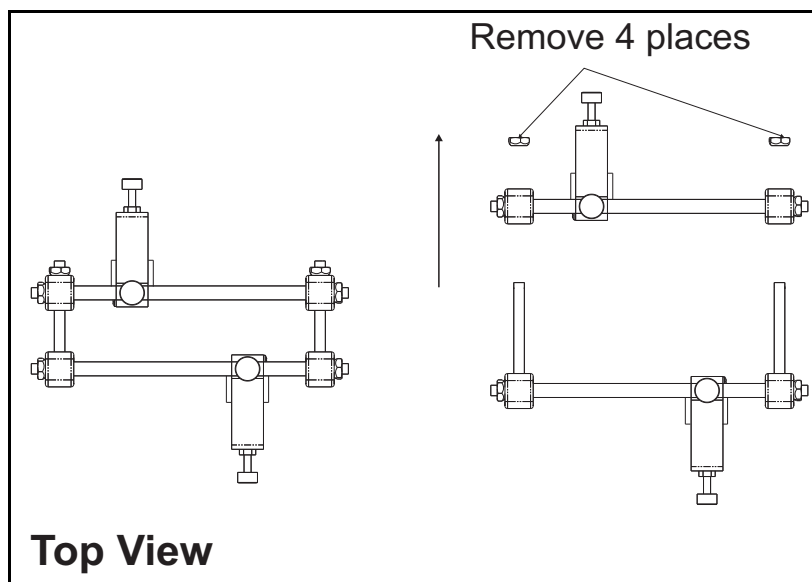

3. Position the clamping fixture as close as possible to the horizontal plane. The fixture should be positioned so the transducers will be located on the opposite sides of the pipe 180° apart, ideally at the 3 and 9 o'clock positions.

IMPORTANT: Do not place the fixture on the pipe so that the transducers are at the top or bottom of the pipe.

Note: Make sure you reassemble the fixture properly to ensure the correct transducer spacing. If the fixture has rulers on the rails, make sure the zero points on each ruler are at the same end of the fixture as shown below.

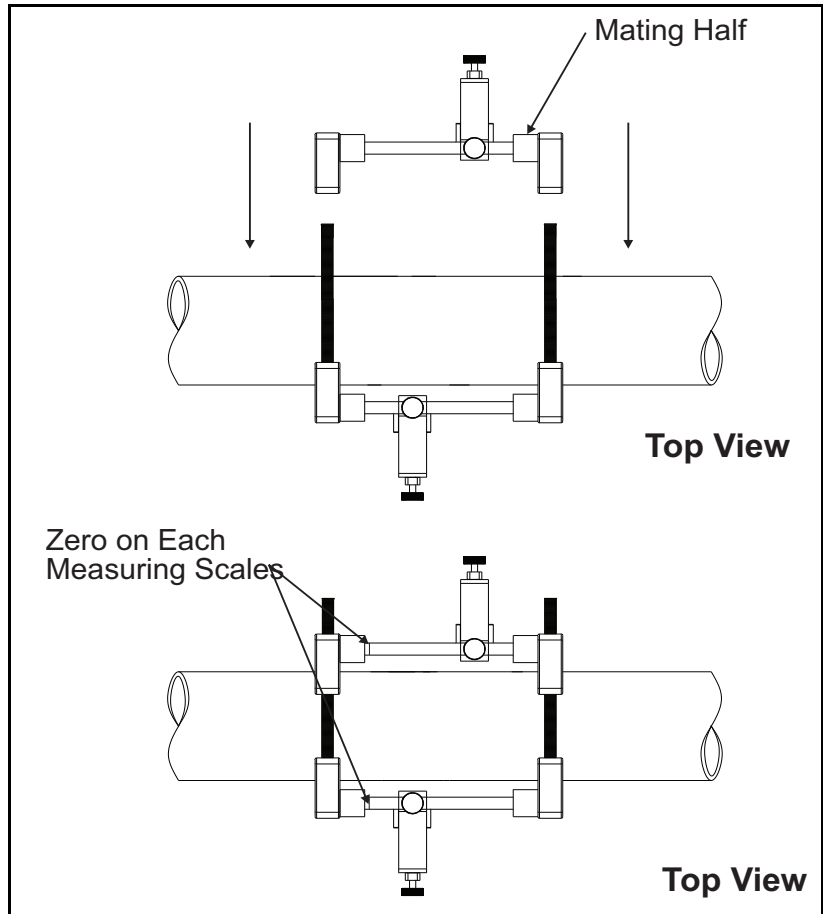

4. Install the four nuts onto the threaded rods with the convex side of the nut facing the fixture. Hand tighten each nut evenly as shown below. **Do not** use a cross-tightening pattern.

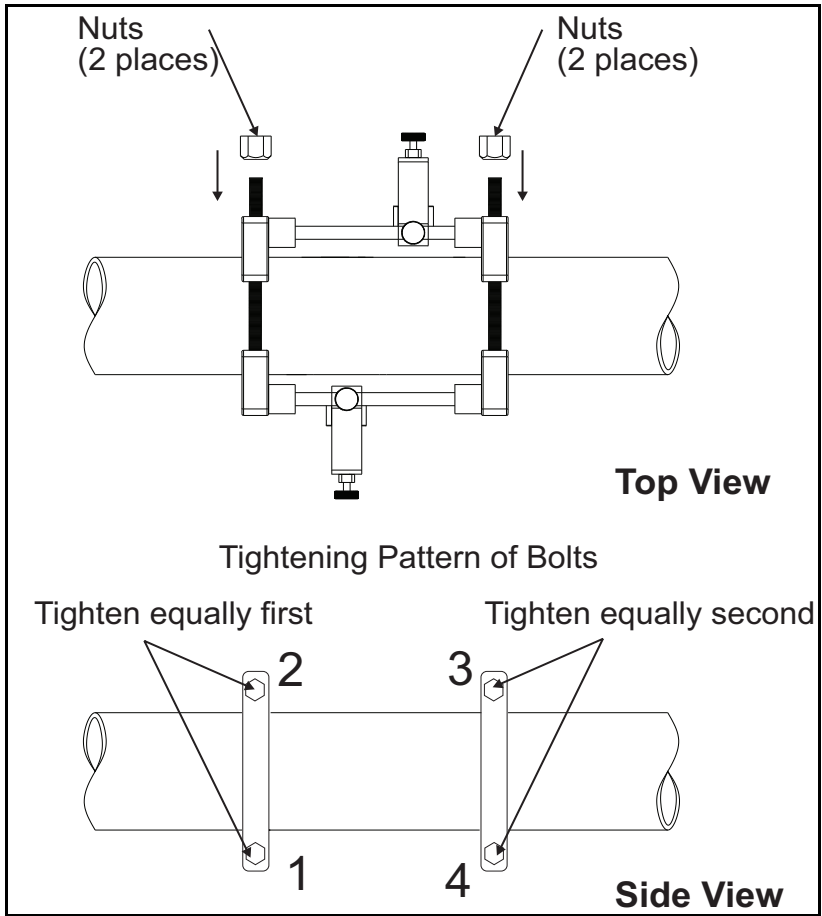

4.3.4 Preparing the Pipe

1. Using a permanent marker, mark the inside edges of the fixture. These lines indicate where to clean the pipe and then apply the dampening material. Make sure you mark both sides of the fixture.

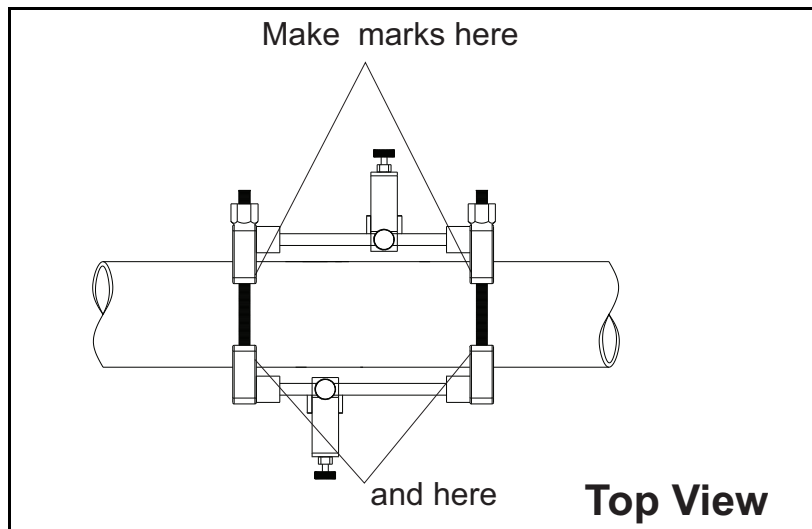

2. Remove the fixture.

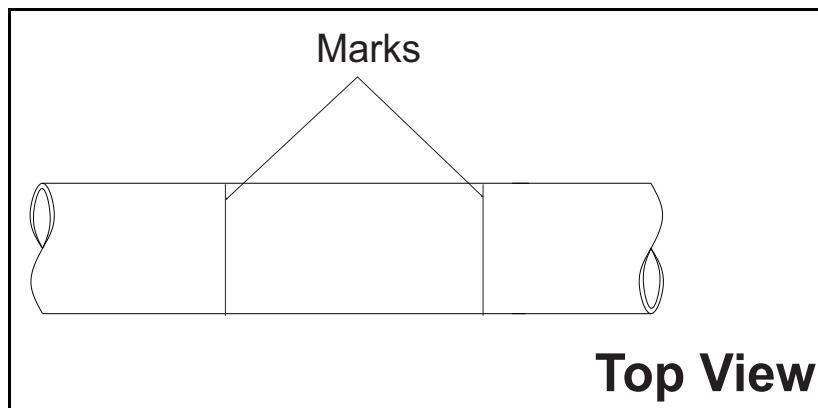

3. Clean the area between the marks. Remove any loose paint or rust with sandpaper or emery cloth. Make sure to preserve the original curvature of the pipe. If the finish is mirror-smooth, use the file to roughen the surface.

TIP: If you are concerned about removing the reference lines during cleaning, use a tape measure and measure 2 ft (60 cm) from one of the reference lines and mark another line (temporary or permanent). This line can be used as a reference point later.

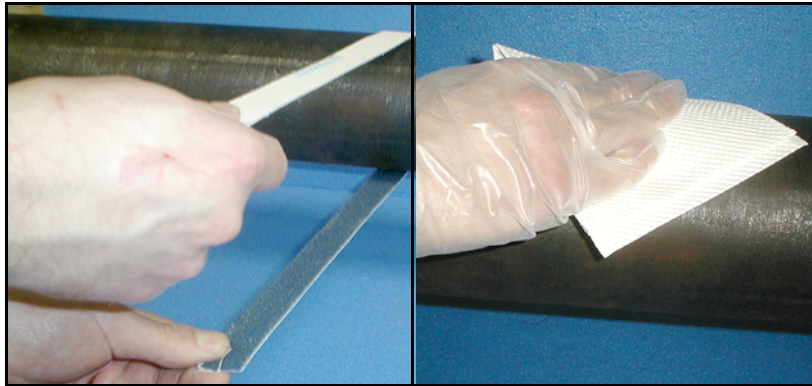

4. Using an emery cloth, clean the cleared area. Again, take care to preserve the original curvature of the pipe.
5. With an ultrasonic thickness gage, measure the pipe thickness at a minimum of six spots on the cleared area. To ensure accuracy, take at least three measurements at each spot and average the results. The thickness should not vary by more than 5% among the six spots. If you encounter more than a 5% variation among the six spots, move to another section of the pipe. Verify that the wall thickness at both transducer locations has less than the 5% variation.

What's Next?

The next series of steps depends on what type of dampening material you are using. If you are using:

- **DMP-1**, proceed to *"Applying the DMP-1 Dampening Material" on page 14*
- **DMP-3**, proceed to *"Applying DMP-3 Compound" on page 16*
- **PDJ**, proceed to *"Installing the Pipe Dampening Jacket - PDJ" on page 18*

4.3.5 Applying the DMP-1 Dampening Material

1. Unroll the DMP-1 material and peel back a small part of the paper backing. Do not completely remove the paper backing. One 9.5-in. (24-cm) roll fits between the lines marked on the pipe.
2. Use a dry towel or rag to dry the pipe.

IMPORTANT: The dampening material will only adhere to the pipe correctly if the pipe is completely dry.

3. Roll the DMP-1 dampening material around the pipe, peeling the paper backing off as you go. Place the material between the marks that represent the inside edge of the fixture, as shown below. Use the entire length supplied, wrapping the material over itself.



4. Reinstall the fixture making sure the fixture is reassembled correctly to ensure the correct transducer spacing (see *Step 3* in *"Installing the Fixture"* on page 9).
5. Loosely mount the transducers on top of the dampening material.
6. With a marker, trace around the transducer footprint. Remove the fixture and the transducers.



7. Use a utility knife to cut out the area under the transducer footprint. Peel the cut material off the pipe, as shown below.

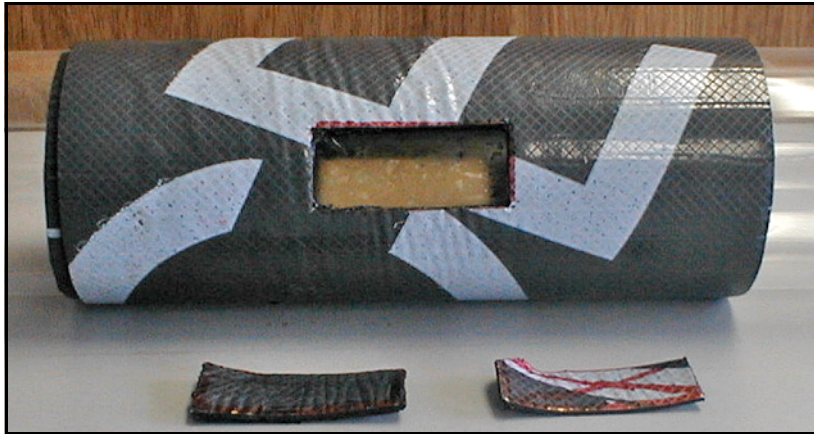

8. Reinstall the fixture on the pipe (see *Step 3* in *"Installing the Fixture"* on page 9). After the fixture is on the pipe, tighten the four nuts with a 1-in. box wrench. **DO NOT** use a cross-tightening pattern.
9. Use the second strip of dampening material for additional dampening. Unroll the second strip of dampening material and cut the strip into two pieces, each 4.5-in. (11 cm) wide.
10. Wrap each of these strips around the pipe on the outside edge of the clamping fixture, one upstream and one downstream. The completed dampening material installation should appear similar to the figure below, which also shows the transducers.

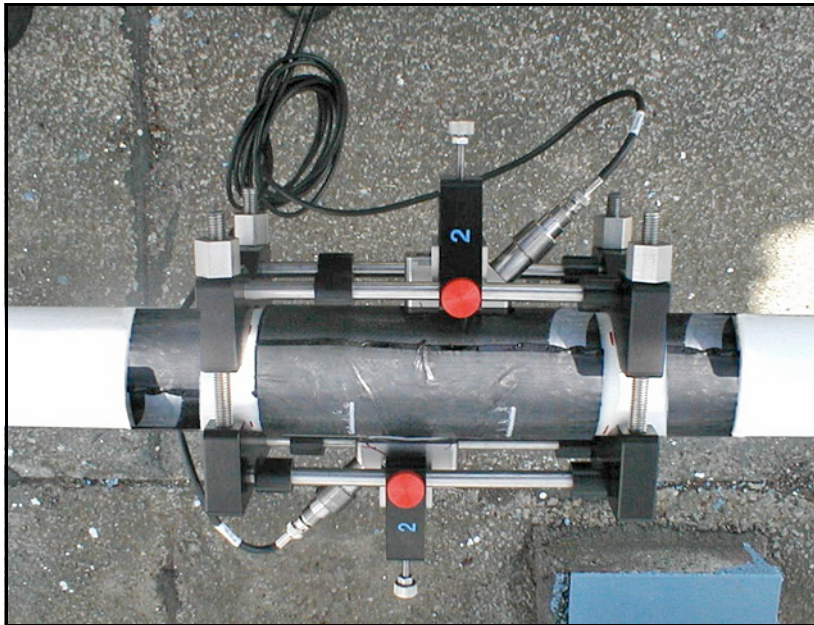

11. To mount transducers, refer to *"Mounting the Transducers"* on page 20.

4.3.6 Applying DMP-3 Compound



WARNING! Be sure to wear proper eye and skin protection when applying the dampening compound. Also, make sure there is proper ventilation.

1. Use a dry towel or rag to dry the pipe.

IMPORTANT: The dampening material will only adhere to the pipe correctly if the pipe is completely dry.



WARNING! In high-temperature applications, after the dampening compound is applied to the pipe, the compound may drip and will cause severe burns upon contact with bare skin. Also, be sure not to inhale the fumes generated during the DMP-3 curing cycle.

2. While wearing protective gloves, place a piece of the **DMP-3** material on top of the pipe and use the palm of your hand to press it onto the pipe.

Note: If the measurement point is near a flange or weld, apply **DMP-3** between that structure and the fixture as well.

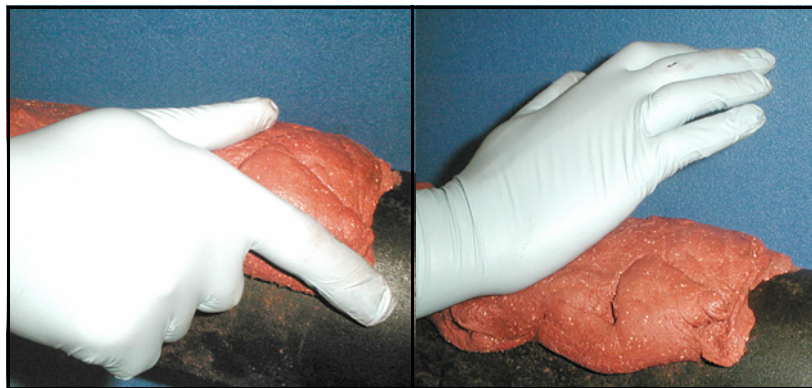

3. Spread the **DMP-3** material so that it covers the whole area under the fixture to a thickness of about 0.25 in. (6 mm).



4. Reinstall the fixture around, but not on, the DMP-3 material making sure the fixture is reassembled properly to ensure the correct transducer spacing. (see *Step 3* in "*Installing the Fixture*" on page 9). After the fixture is on the pipe, tighten the four nuts with a 1-in. box wrench. **DO NOT** use a cross-tightening pattern.

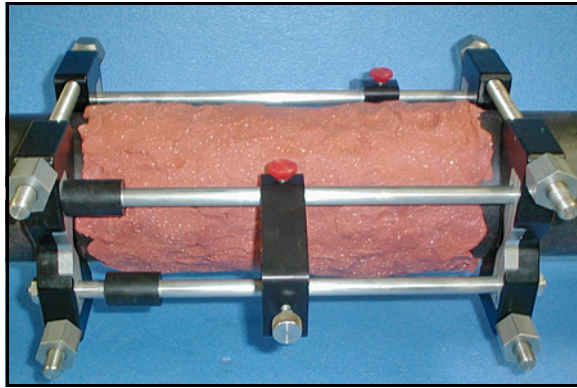

5. Using a putty knife or other suitable tool, remove the DMP-3 material from the transducer locations.

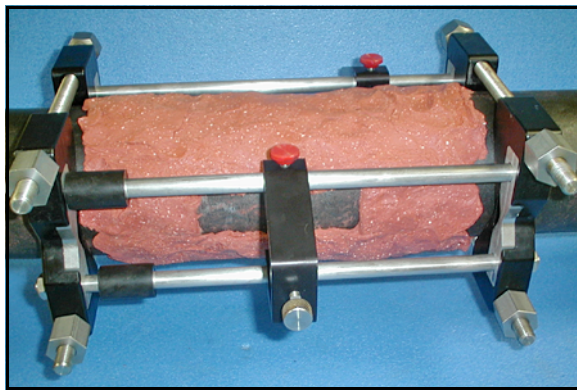

6. To mount the transducers, refer to *"Mounting the Transducers"* on page 20.

4.3.7 Installing the Pipe Dampening Jacket - PDJ



WARNING! Be sure to wear proper eye and skin protection when applying the dampening compound. Also, make sure there is proper ventilation.

1. Remove the backing from the inside of the pipe dampening jacket.

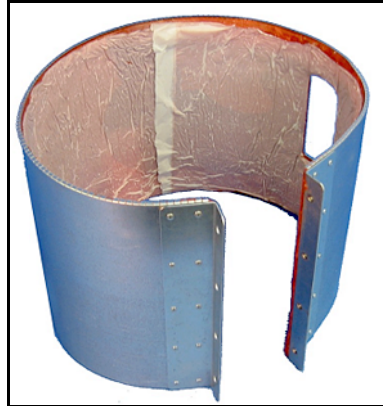

WARNING! In high-temperature applications, after the dampening compound is applied to the pipe, the compound may drip and will cause severe burns upon contact with bare skin. Also, be sure not to inhale the fumes generated during the DMP-3 curing cycle.

2. Install the jacket on the pipe so that the jacket is between the marks, and be sure that the transducer holes are located at the 3 o'clock and 9 o'clock positions.

Note: Panametrics recommends placing the PDJ on the pipe so that the seam is as close to the top of the pipe as possible. Placing the seam at the top of the pipe reduces the amount of dripping.

3. Tighten the clamping screws evenly in sequence (see the figure below), taking care not to twist or warp the PDJ. During tightening, some fluid and dampening material will drip from the bottom of the jacket.

Note: As the dampening material dries out over several hours after installation, its effectiveness increases.

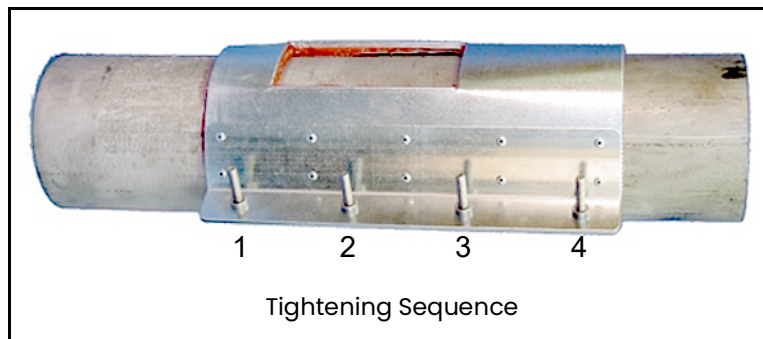

4. Install the transducer mounting fixture over the jacket (see *Step 3* in "*Installing the Fixture*" on page 9). Adjust the fixture so the transducer block is located over the pre-stamped transducer holes from the flowmeter spacing calculations. The figure below shows the PDJ and the fixture with the installed transducers.

IMPORTANT: Make sure the mounting fixture is reassembled properly to ensure the correct transducer spacing.

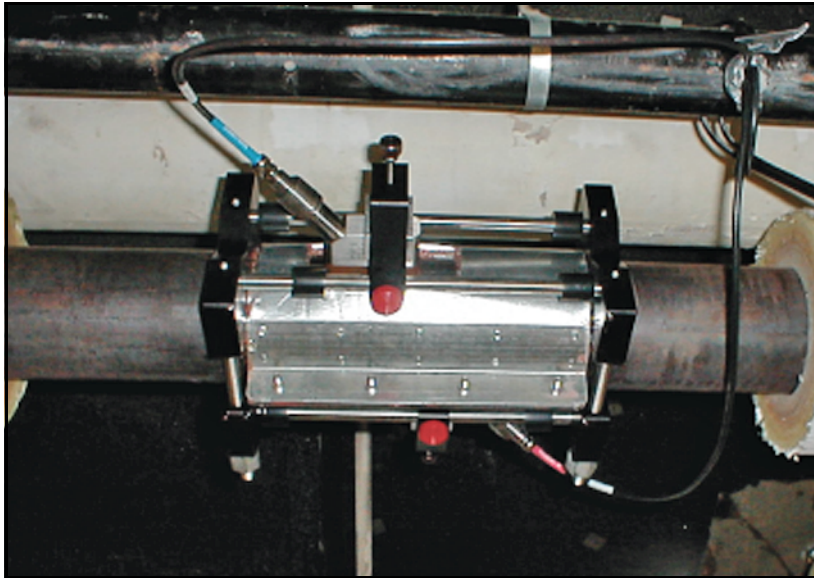

5. After the fixture has been mounted on the pipe, tighten the four nuts with a 1-in. box wrench. **DO NOT** use a cross-tightening pattern.
6. To mount the transducers, refer to *"Mounting the Transducers"* on page 20.

4.3.8 Mounting the Transducers

To mount the transducers, proceed as follows:

- If your installation requires junction boxes, begin with step 1 below.
- If your installation does not require junction boxes, begin with step 3 below.

Note: For clarity, the dampening material is not shown in the following illustrations.

1. Apply a thread sealant to the transducer threads. A thread sealant is not required within the United States, but it is required to maintain ATEX certification for the installation.
2. Before mounting the transducers, thread the junction box onto the transducer, and tighten it with a wrench to a torque of 40 lb-ft (54 N-m). Be sure to orient the cover of the junction box so it is accessible to make cable connections after the box is installed.

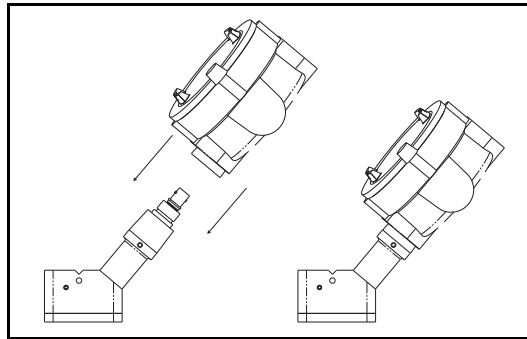

3. Apply a bead of couplant 0.25 in. (6 mm) wide along the entire length of each transducer face, as shown below. The purpose of the couplant is to prevent an air gap between the transducer and the pipe. The air in such a gap would attenuate transducer signal.

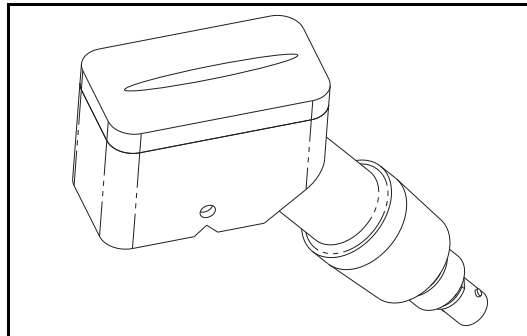

IMPORTANT: To prevent the loss of couplant, do not slide the transducer face with the couplant bead along the surface of the pipe when mounting the transducer.

4. Proceed as follows:
 - If you are using couplant CPL-1, CPL-2 or CPL-3, proceed to step 5 on the next page.
 - If you are using couplant CPL-16, proceed to step 7 on the next page.
5. Insert the transducers into the mounting blocks, making sure the BNC connectors (or junction boxes) point away from the center of the fixture (see the figure below). Tighten the pressure bolts by hand just enough to bring the transducers into contact with the pipe surface and to hold the transducers in place.

IMPORTANT: Do not use a wrench or pliers on the pressure bolts.

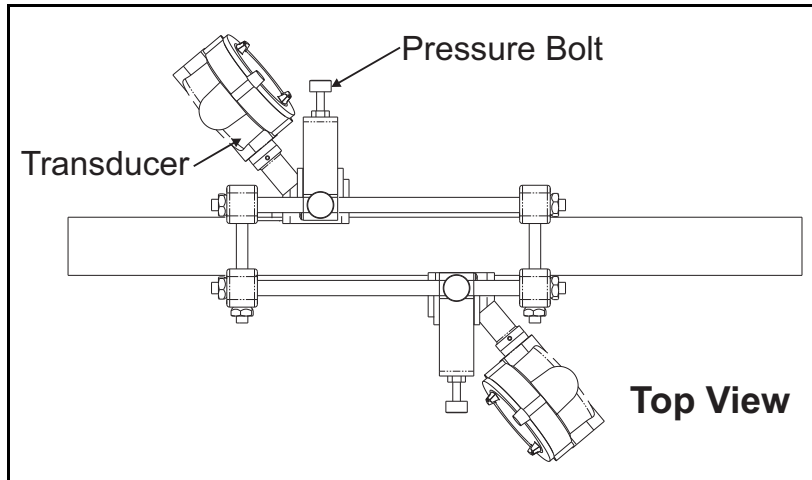

6. Skip to step 10 on the next page.
 7. Insert the transducers into the mounting blocks, making sure the BNC connectors (or junction boxes) point away from the center of the fixture (see the figure above). Slightly tighten the pressure bolts to hold the transducers in place while the couplant begins to spread. Wait one minute.
- IMPORTANT:** Do not use a wrench or pliers on the pressure bolts.
8. Turn the pressure bolts 1/4 turn and wait one minute again. Do not overtighten the pressure bolts or the mounting fixture will be forced away from the pipe surface.
 9. Repeat step 8 a second time, and then proceed to step 10 on the next page.
 10. For permanent applications, tighten the locking nuts with a wrench to maintain constant pressure and to prevent loosening of the transducers due to vibration and thermal expansions.

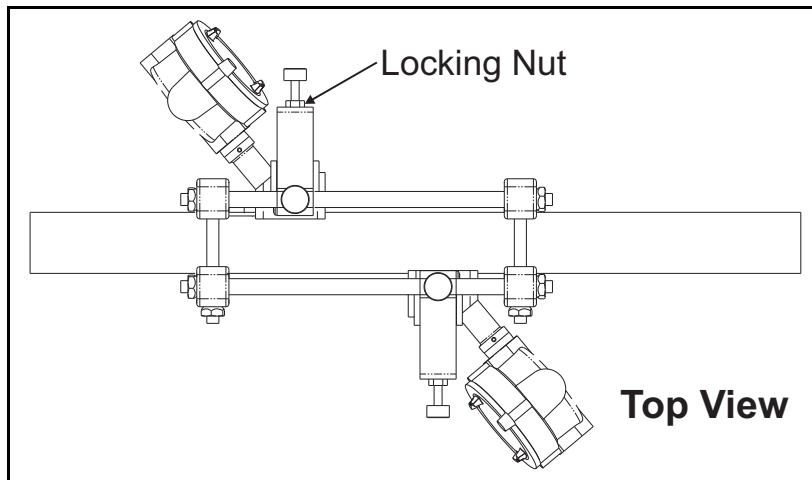

4.4 What's Next?

Having completed installation of the *V Series Clamping Fixture* and the *transducers*, you should now do all of the following:

- Refer to the installation section of your flowmeter *Startup Guide* to make the transducer electrical connections. The cables shall be secured at the junction boxes to prevent twisting and pulling.
- Make a note of the installation date and set a schedule for periodic inspection and tightening of the clamping fixture nuts to ensure that the clamping fixture does not become loose and fall, possibly causing injury.

- After the flowmeter is placed into operation, measure and record the signal strength of each transducer using the flowmeter's diagnostics menu. This value will be helpful when making periodic checks or for troubleshooting future problems. Refer to your flowmeter *Startup Guide* for more details.

4.5 Installing the PI Fixture and Transducers

The PI clamping fixture is used for pipes from 6 in. to 30 in. (150 mm to 750 mm) in diameter. It consists of two mounting blocks and comes with either a chain (temporary) or strap (permanent), depending on the application.

Installing the PI clamping fixture and transducers requires the following steps:

- Preparing the pipe
- Surveying the pipe
- Applying the dampening material
- Installing the fixture
- Mounting the transducers

Refer to the following section to properly prepare for installation

4.5.1 Tools and Equipment Needed

Installing the fixture and transducers requires various tools. You will also need additional tools to apply the dampening material. Refer to *Table 2* below for a complete list of everything you will need.

Fixture and Transducers		
<ul style="list-style-type: none"> • permanent marker • sandpaper • file • emery cloth • ultrasonic thickness gage • thread sealant (for junction boxes only) • 7/16" box wrench or 4" adjustable wrench • 1" box wrench or 10" adjustable wrench • 		
DMP-1	DMP-3	PDJ
<ul style="list-style-type: none"> • utility knife 	<ul style="list-style-type: none"> • gloves • spatula or putty knife (to remove access dampening compound) 	<ul style="list-style-type: none"> • 7/16" box wrench or a 4" adjustable wrench

4.5.2 Preparing the Pipe

To prepare the pipe for installing the transducer mounting fixture, complete the following steps:

1. Remove any pipe insulation from the installation site.

Note: *Make sure you clear an area that is large enough for the transducers and the dampening material.*

2. Remove any loose paint or rust with sandpaper or emery cloth. Make sure to preserve the original curvature of the pipe. If the finish is mirror-smooth, use the file to roughen the surface.

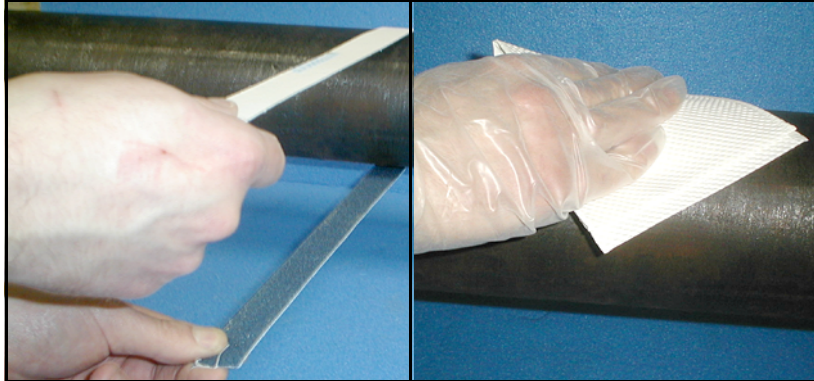

3. Using an emery cloth, clean the cleared area. Again, take care to preserve the original curvature of the pipe.
4. With an ultrasonic thickness gage, measure the pipe thickness at a minimum of six spots on the cleared area. To ensure accuracy, take at least three measurements at each spot and average the results. The thickness should not vary by more than 5% among the six spots. If you encounter more than a 5% variation among the six spots, move to another section of the pipe. Verify that the wall thickness at both transducer locations has less than the 5% variation.

4.5.3 Surveying the Pipe

1. Measure the *pipe circumference* to an accuracy $\pm 1/16$ in. (± 2 mm).

IMPORTANT: Do not use a calculated value or a nominal value for the circumference.

2. Tightly wrap the layout tape around the entire pipe and line up the edges. Use the entire tape for best results. Using the tape as a template guide, mark a line all the way around the circumference of the pipe.

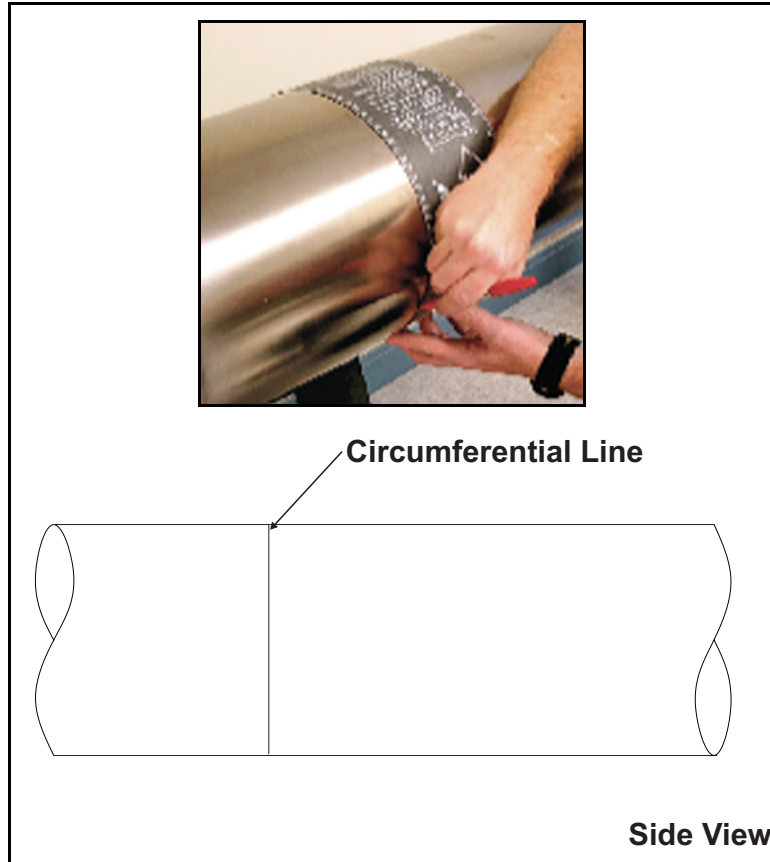

3. Line up the zero scale mark of the layout tape at the desired transducer location (e.g., 3 or 9 o'clock) for the first transducer. Mark a line (*origin line*) at least 12 in. (30 cm) long.

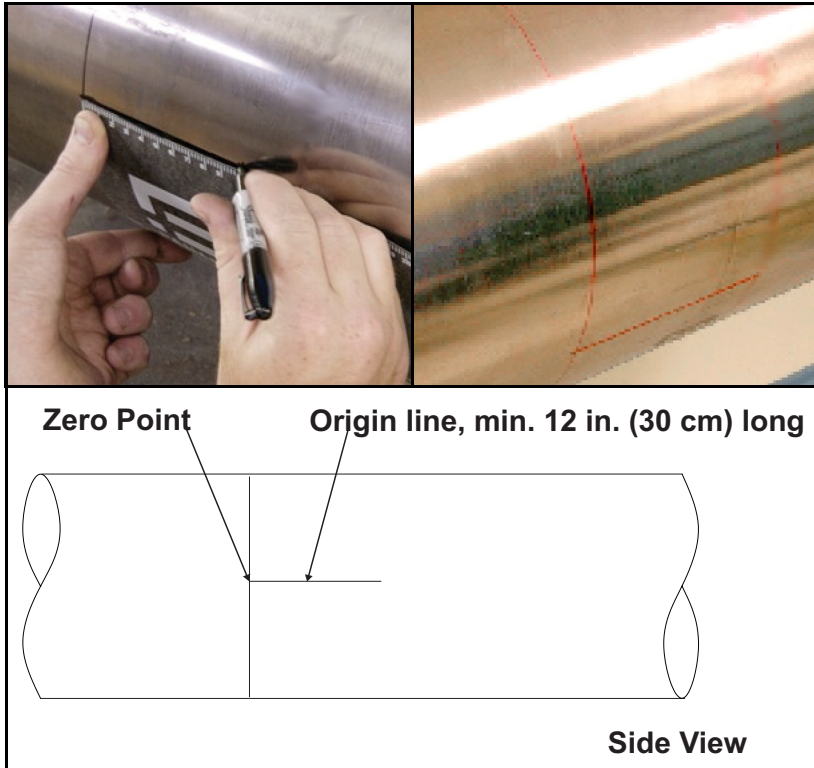

- To find the corresponding point on the opposite side of the pipe (180° away), divide the measured pipe circumference by 2 and measure this distance along the circumferential line from the zero point. Take the 180° point measurement from both over the top of the pipe and under the bottom of the pipe (on a horizontal pipe) to ensure accuracy of the installation. Mark a small scribe line at the 180° point.

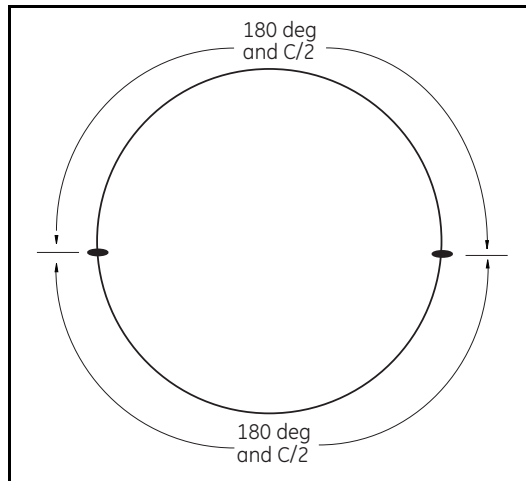

- Mark another origin line at the 180° point at least 12 in. (30 cm) long.

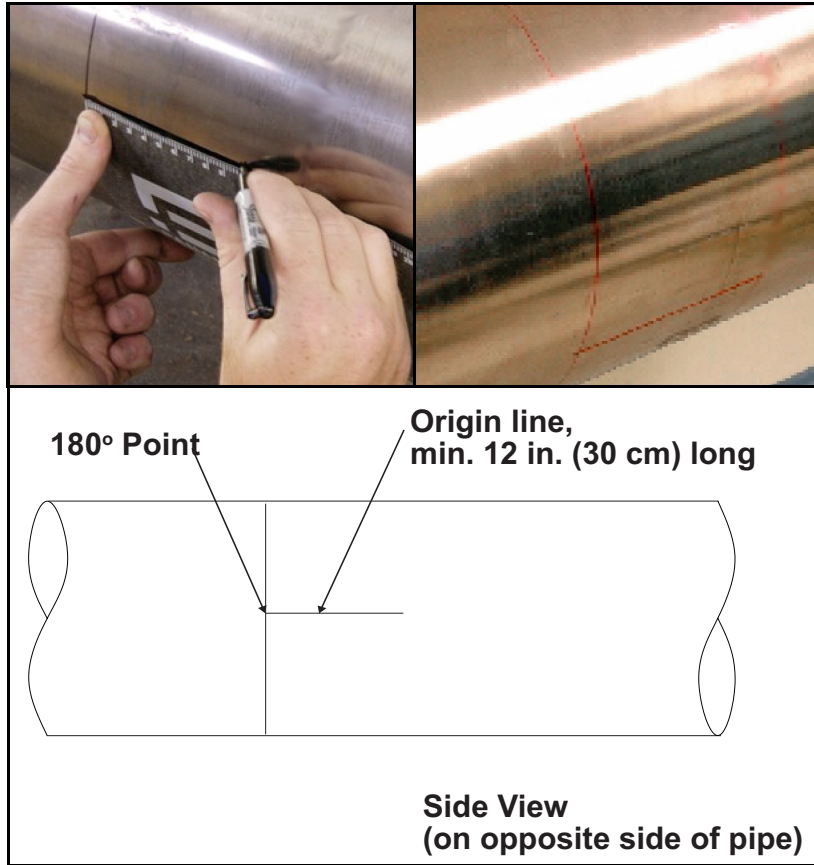

What's Next?

The next series of steps depends on what type of dampening material you are using:

- For PDJ, proceed to *"Applying the Pipe Dampening Jacket - PDJ"* on page 27.
- For DMP-1 and DMP-3, proceed to *"Installing the First Transducer Mounting Block"* on page 28.

4.5.4 Applying the Pipe Dampening Jacket - PDJ



WARNING! Be sure to wear proper eye and skin protection when applying the dampening compound. Also, make sure there is proper ventilation.

1. Remove the backing from the inside of the pipe dampening jacket.

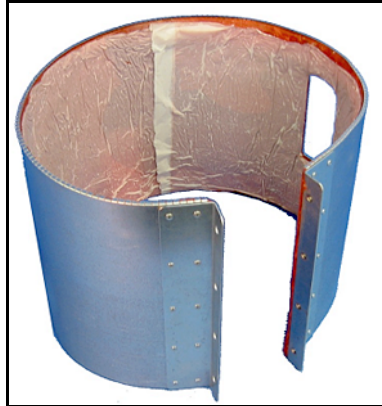

WARNING! In high-temperature applications, after the dampening compound is applied to the pipe, the compound may drip and will cause severe burns upon contact with bare skin. Also, be sure not to inhale the fumes generated during the DMP-3 curing cycle.

2. Install the jacket on the pipe so that the jacket is between the marks, and be sure that the transducer holes are located at the 3 o'clock and 9 o'clock positions.
Note: Panametrics recommends placing the PDJ on the pipe so that the seam is as close to the top of the pipe as possible. Placing the seam at the top of the pipe reduces the amount of dripping.
3. Tighten the clamping screws evenly in sequence (see the figure below), taking care not to twist or warp the PDJ. During tightening, some fluid and dampening material will drip from the bottom of the jacket.
Note: As the dampening material dries out over several hours after installation, its effectiveness increases.

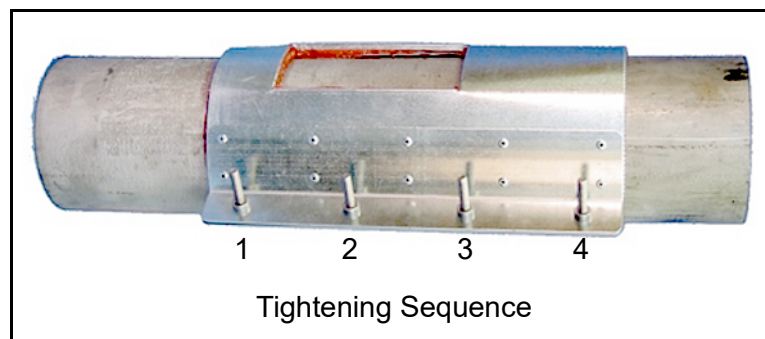

4.5.5 Installing the First Transducer Mounting Block

To install the first transducer mounting block, complete the following steps:

Note: For clarity, the PDJ is not shown in the following illustrations.

1. Loosen the wing nuts up to the end of the J-hooks on both of the mounting blocks. [Note: If the mounting blocks have straps, this step is required.]

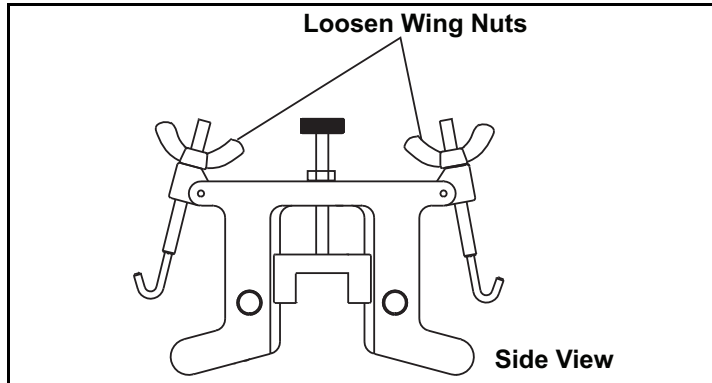

2. Line up the front edge of one of the mounting blocks so that it lines up with the circumferential line and is centered over the origin line (see the figure below).

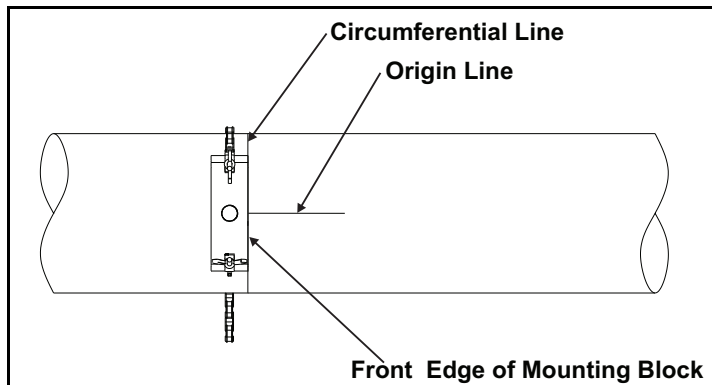

3. Carefully wrap the chain or strap around the pipe, taking care not to twist it. Then, hook the chain into the J-hook. If you are using a strap, insert the J-hook into the smaller round holes on the strap.

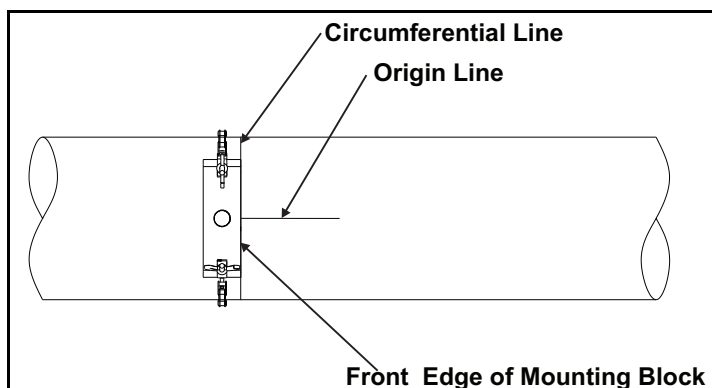

4. Tighten the chain or strap around the pipe loosely enough so that the mounting block can be moved for minor adjustments, but not so loose that it will move without being touched.

5. A “dummy” transducer block is shipped with the PI fixture to ensure that the mounting blocks are properly aligned on the pipe. Insert the dummy transducer block into the mounting block so that the front edge of the dummy transducer block lines up with the circumferential line as shown below.

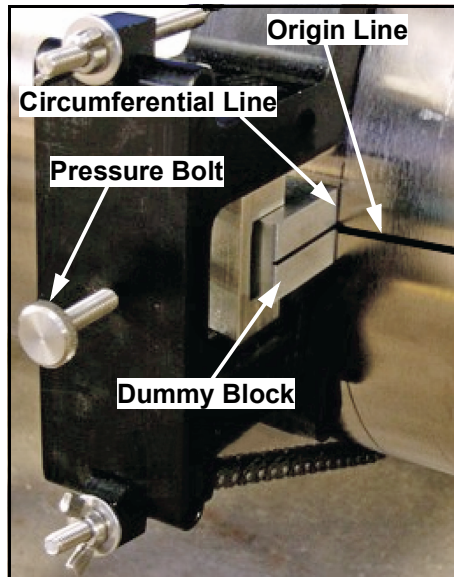

6. Use the pressure bolt to secure the dummy transducer block in place. Hand-tighten the bolt just enough to hold the block in place. Do not overtighten the block or the holder will be forced away from the pipe surface.

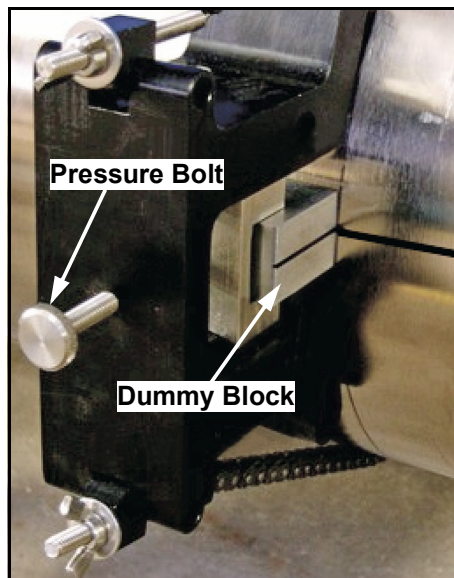

7. Adjust the mounting block so the indicator line on the dummy transducer block lines up with the origin line on the pipe. Also, make sure the front edge of the mounting block is still lined up with the circumferential line on the pipe. After the mounting block is properly aligned, tighten the chain or strap to secure the block in place.

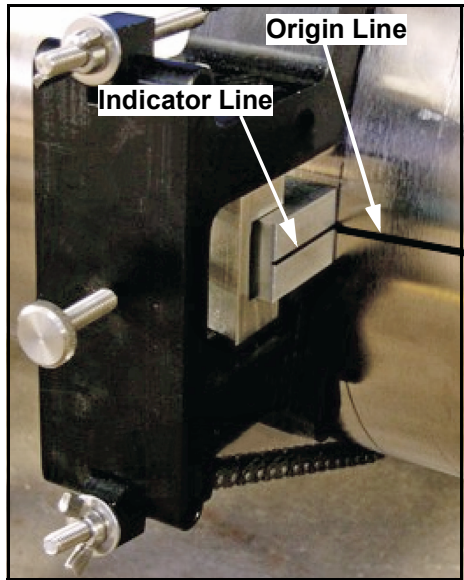

4.5.6 Installing the Second Transducer Mounting Block

1. On the opposite side of the pipe from the first transducer location, mark the transducer spacing point (see *"Obtaining the Transducer Spacing"* on page 6) on the origin line. To do this, measure from the zero point on the origin line and mark the transducer spacing point with a crosshair.

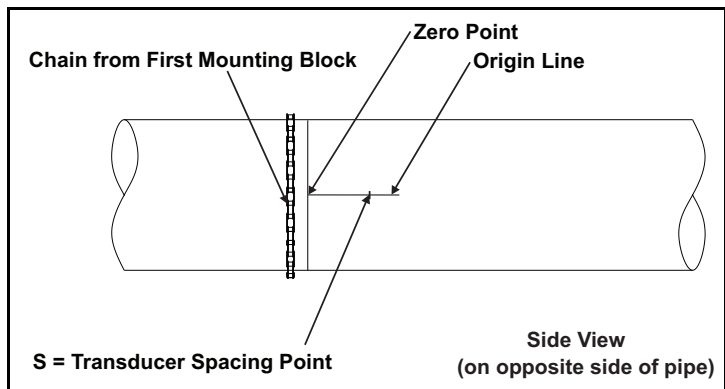

2. Using the layout tape, make a second circumferential line around the entire pipe at the second transducer spacing mark.

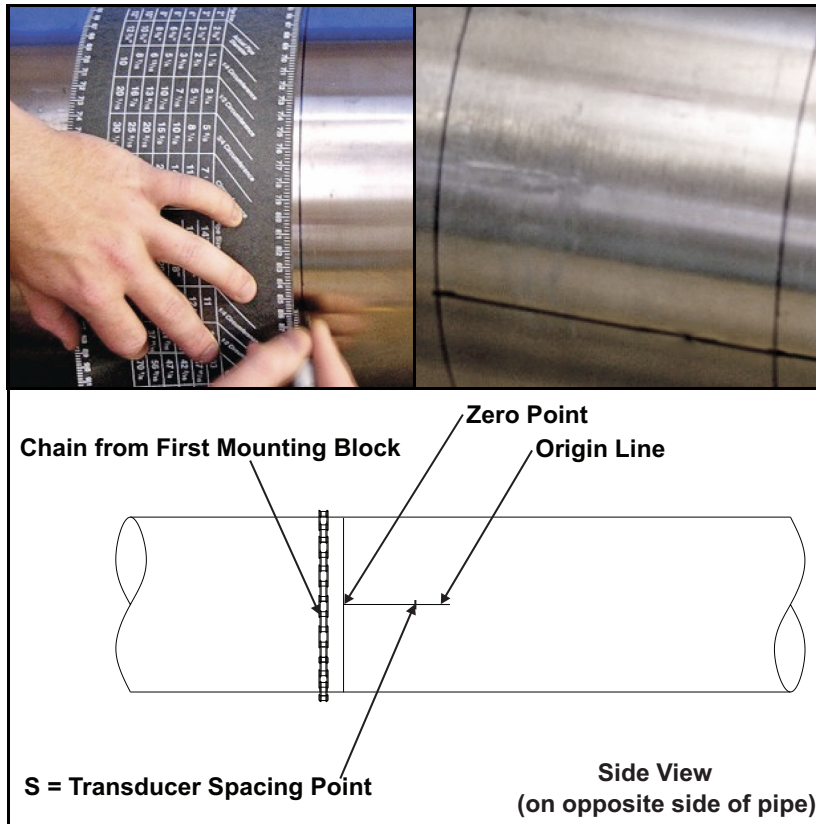

3. Line up the second mounting block so that it is centered over the origin line and the front edge of the mounting block lines up with the transducer spacing point as shown below.
- IMPORTANT:** Make sure you use the same edge on both transducer mounting blocks (either upstream or downstream from the flow measurement point). If you do not, the transducer spacing will be incorrect.
4. Carefully wrap the chain or strap around the pipe, taking care not to twist it. Then, hook the chain into the J-hook. If you are using a strap, insert the J-hook into the smaller round holes on the strap.
 5. Tighten the chain or strap around the pipe loosely enough so that the mounting block can be moved for minor adjustments, but not so loose that it will move without being touched.

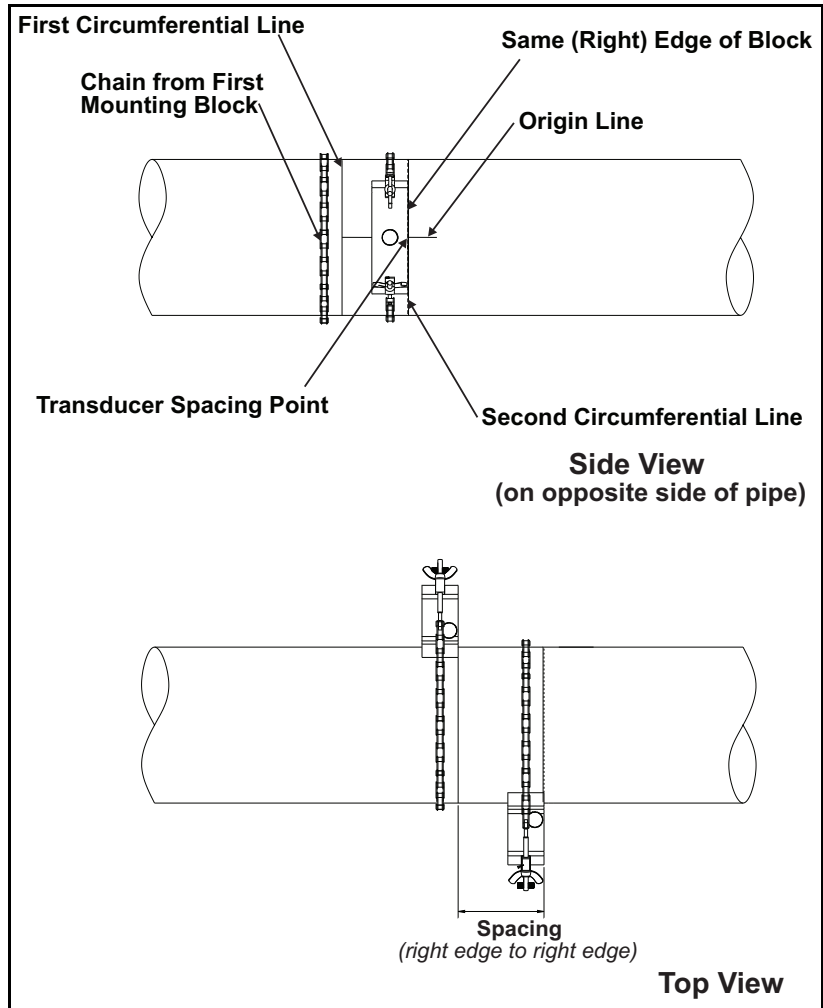

- Remove the dummy transducer block from the first mounting block and install it into the second mounting block. Insert the dummy block into the mounting block so the front edge of the dummy block lines up with the circumferential line as shown below.

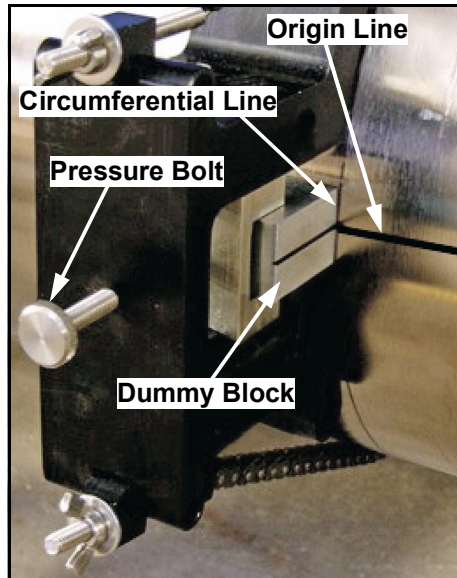

7. Use the pressure bolt to secure the dummy transducer block in place. Hand-tighten the bolt just enough to hold the block in place. Do not overtighten the block or the holder will be forced away from the pipe surface.

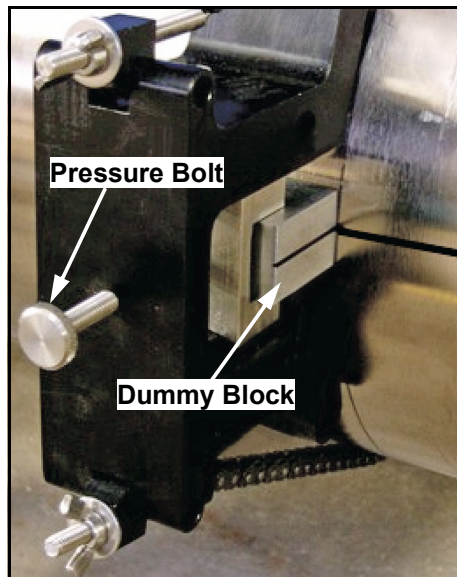

8. Adjust the mounting block so the indicator line on the dummy transducer block lines up with the origin line on the pipe. Also, make sure the front edge of the mounting block is still lined up with the circumferential line on the pipe. After the mounting block is properly aligned, tighten the chain or strap to secure the block in place.

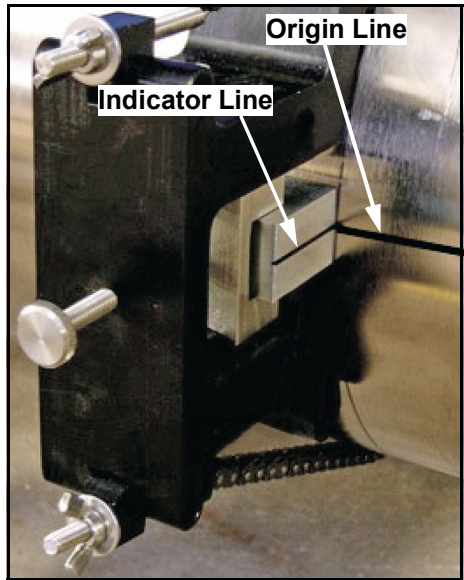

9. Remove the dummy transducer block from the mounting block.

4.5.7 Mounting the Transducers

To mount the transducers, proceed as follows:

- If your installation requires junction boxes, begin with step 1 below.
- If your installation does not require junction boxes, begin with step 3 below.

Note: For clarity, the dampening material is not shown in the following illustrations.

1. Apply a thread sealant to the transducer threads. A thread sealant is not required within the United States, but it is required to maintain ATEX certification for the installation.
2. Before mounting the transducers, thread the junction box onto the transducer, and tighten it with a wrench to a torque of 40 lb-ft (54 N-m). Be sure to orient the cover of the junction box so it is accessible to make cable connections after the box is installed.

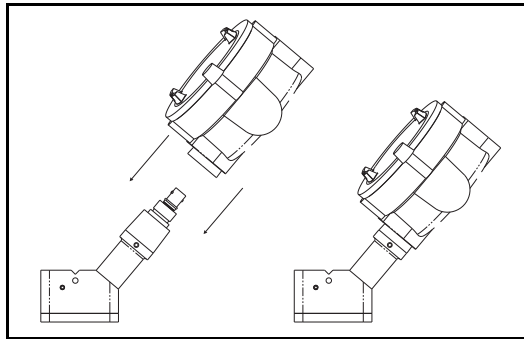

3. Apply a bead of couplant 0.25 in. (6 mm) wide along the entire length of each transducer face, as shown below. The purpose of the couplant is to prevent an air gap between the transducer and the pipe. The air in such a gap would attenuate transducer signal.

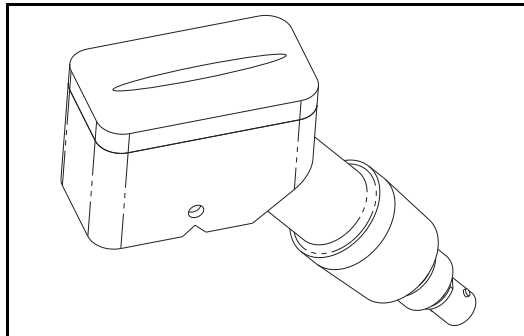

IMPORTANT: To prevent the loss of couplant, do not slide the transducer face with the couplant bead along the surface of the pipe when mounting the transducer.

4. Proceed as follows:
 - If you are using couplant CPL-1, CPL-2 or CPL-3, proceed to step 5 on the next page.
 - If you are using couplant CPL-16, proceed to step 7 on the next page.
5. Insert the transducers into the mounting blocks, making sure the BNC connectors (or junction boxes) point away from the center of the fixture (see the figure below). Tighten the pressure bolts by hand just enough to bring the transducers into contact with the pipe surface and to hold the transducers in place.

IMPORTANT: Do not use a wrench or pliers on the pressure bolts.

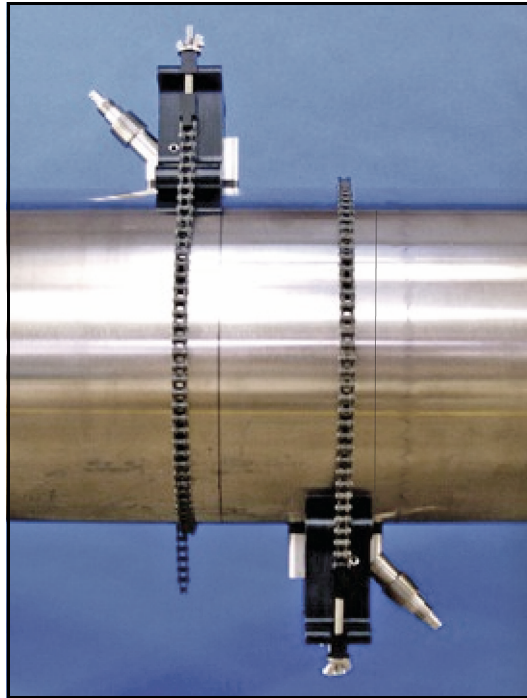

6. Skip to step 10 on the next page.
 7. Insert the transducers into the mounting blocks, making sure the BNC connectors (or junction boxes) point away from the center of the fixture (see the figure above). Slightly tighten the pressure bolts to hold the transducers in place while the couplant begins to spread. Wait one minute.
- IMPORTANT:** Do not use a wrench or pliers on the pressure bolts.
8. Turn the pressure bolts 1/4 turn and wait one minute again. Do not overtighten the pressure bolts or the mounting fixture will be forced away from the pipe surface.
 9. Repeat step 8 a second time, and then proceed to step 10 on the next page.
 10. For permanent applications, tighten the locking nuts with a wrench to maintain constant pressure and to prevent loosening of the transducers due to vibration and thermal expansions.

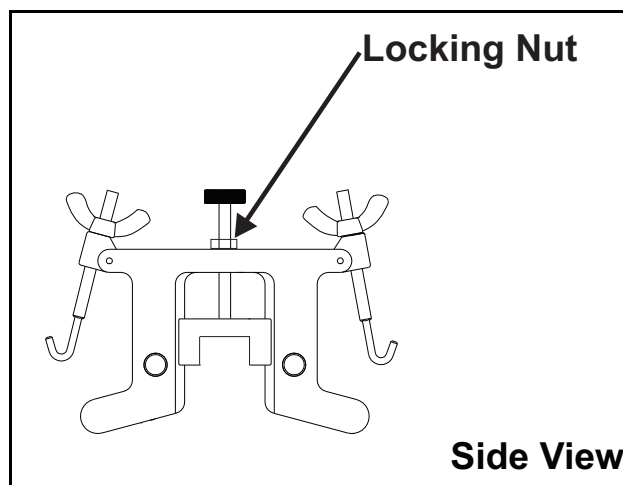

The next series of steps depends on what type of dampening material you are using. If you are using:

- **DMP-1**, proceed to *"Installing DMP-1 Dampening Material"* on page 37

- DMP-3, proceed to “Applying DMP-3 Compound” on page 39
- PDJ, proceed to “What’s Next?” on page 39

4.5.8 Installing DMP-1 Dampening Material

1. Measure the approximate distance (D) between the two transducers, as shown below.

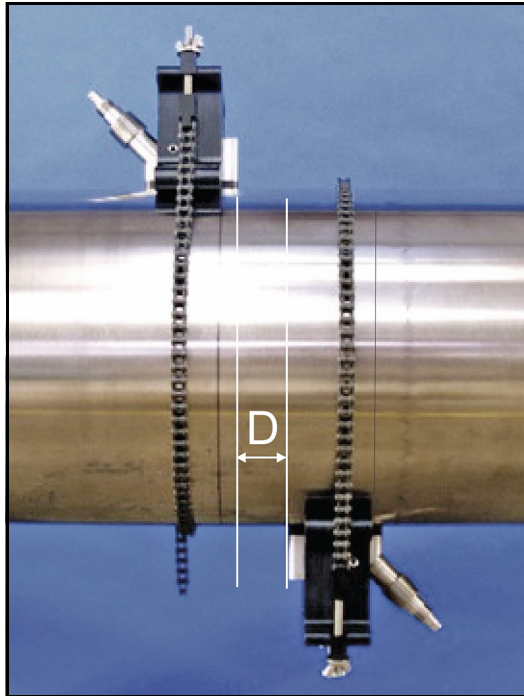

2. Lay the first strip of dampening material on a flat surface. Using a utility knife, cut a strip with a width equal to the distance (D) between the transducers, as shown in the figure above. Then, peel back a small part of the backing paper, but do not completely remove the backing paper.

3. Use a dry towel or a rag to thoroughly dry the pipe.

IMPORTANT: The dampening material will only adhere to the pipe correctly if the pipe is completely dry.

4. Wrap the strip of dampening material around the pipe in the space between the transducers, peeling the backing paper off as you proceed.
5. Lay the second strip of dampening material on a flat surface. Using a utility knife, cut the strip into two equal pieces with a width of 4.5 in. (12 cm). Then, peel back a small part of the backing paper on each piece, but do not completely remove the backing paper.
6. Make sure the pipe is dry, then wrap each of these dampening material strips around the pipe at the outside edge of each mounting block, peeling the backing paper off as you proceed. One strip will be upstream from the flow measurement point, while the other strip will be downstream from the flow measurement point. The completed installation should appear similar to the figure below (for clarity, the junction boxes are not shown).

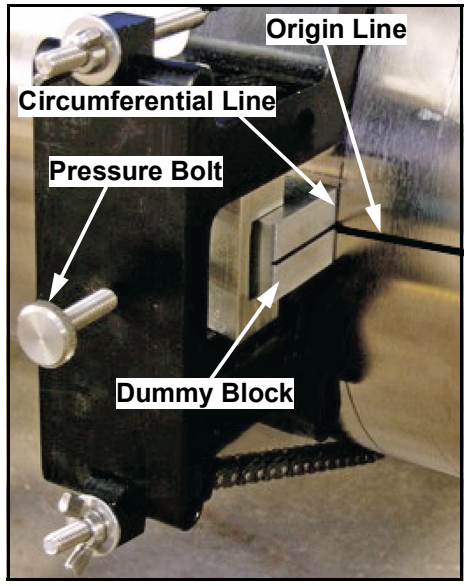

7. Proceed to *“What’s Next?”* on page 39.

4.5.9 Applying DMP-3 Compound



WARNING! Be sure to wear proper eye and skin protection when applying the dampening compound. Also, make sure there is proper ventilation.

1. Use a dry towel or rag to dry the pipe.

IMPORTANT: The dampening material will only adhere to the pipe correctly if the pipe is completely dry.



WARNING! In high-temperature applications, after the dampening compound is applied to the pipe, the compound may drip and will cause severe burns upon contact with bare skin. Also, be sure not to inhale the fumes generated during the DMP-3 curing cycle.

2. While wearing protective gloves, place a piece of the **DMP-3** material on top of the pipe and use the palm of your hand to press it onto the pipe.

Note: As the dampening material dries out over several hours after installation, its effectiveness increases.

3. Spread the **DMP-3** material so that it covers the entire area around the mounting blocks to a thickness of about 0.25 in. (6 mm).

Note: If the measurement point is near a flange or weld, apply **DMP-3** between that structure and the fixture as well.

4.6 What's Next?

Having completed installation of the *PI Clamping Fixture* and the *transducers*, you should now do all of the following:

- Refer to the installation section of your flowmeter *Startup Guide* to make the transducer electrical connections. The cables shall be secured at the junction boxes to prevent twisting and pulling.
- Make a note of the installation date and set a schedule for periodic inspection and tightening of the clamping fixture nuts to ensure that the clamping fixture does not become loose and fall, possibly causing injury.
- After the flowmeter is placed into operation, measure and record the signal strength of each transducer using the flowmeter's diagnostics menu. This value will be helpful when making periodic checks or for

4.7 Maintenance

The transducers, couplant, clamping fixture and dampening material required for your installation are all provided by Panametrics. After you have completed your installation, little maintenance is required. However, see *Table 1* below for those routine maintenance procedures which are recommended to ensure accurate operation.



Table 1: Maintenance Checks

Component	Interval	Maintenance Check	Comments
Transducer	N/A	No additional adjustments or maintenance is needed. If you suspect something is wrong with a transducer or need to replace a transducer, simply loosen the pressure bolt that secures the transducer in place and remove the transducer. If necessary, loosen the locking nut with a wrench. Refer to the appropriate section of this manual to insert a new transducers.	No cleaning required.
Couplant	Verify every 6 months in dry areas (e.g., the desert). Verify every 12 months in other areas.	Measure the signal strength using the flowmeter diagnostics menu and compare it to the value recorded at the time of installation. Good and bad limits are listed in the flowmeter <i>Service Manual</i> and <i>Startup Guide</i> .	No cleaning required.
Dampening Material	N/A	The expected service life is 25 years. Consult Panametrics for additional information if needed.	No cleaning required.
Clamping Fixture	Determined by user.	Periodic inspection and tightening of the clamping fixture nuts is required to ensure that the clamping fixture does not become loose and fall, possibly causing injury.	No cleaning required.

4.8 Transducer Specifications





4.8.1 C-RL Transducer Numbers 301, 302, 307 and 308

Table 2:

Specification	Transducer Number			
	301	302	307	308
Primary Use	Mid-sized pipes, high temperature	Small pipes, high temperature	Mid-size pipes, very high temperature	Small pipes, very high temperature
Installation Type	Clamp-on			
Material of Construction	316 stainless steel and plastic			
Pipe Sizes	>2 to 12" (>50 to 300 mm)	3/4 to 2" (20 to 50 mm)	>2 to 12" (>50 to 300 mm)	3/4 to 2" (20 to 50 mm)
Clamping Fixture	CFG-V4, CFG-V8, CFG-V12	CFG-V1, CFG-V4	CFG-V4, CFG-V8, CFG-V12	CFG-V1
Operating Frequency	500 kHz	1.0 MHz	500 kHz	1.0 MHz
Electrical Rating	200 V peak-to-peak, 5 mA			
Process Temperature Range	-40 to 176°C (-40 to 349°F)		-40 to 230°C (-40 to 446°F)	
North American Certification - Explosion-proof	General Purpose			
European Certification - Flameproof	General Purpose			
North American Certification - Weatherproof	 IP66, TYPE 4X 200Vpp, 5mA C US			
European Certification - Weatherproof	IP 66 			
Note: The transducer is protected by a suitable fuse located in the flowmeter electronics. The fuse has a rating corresponding with the short circuit current of the power supply.				

4.8.2 C-RL Transducer Numbers 304, 305 and 308

Table 3:

Specification	Transducer Number		
	305	304	306
Primary Use	Small pipes	Low pressure, high velocity; primarily used with TAG technology	Low pressure, high velocity; primarily used with TAG technology
Installation Type	Clamp on		
Material of Construction	316 stainless steel and plastic		
Pipe Sizes	3/4 to 2" (20 to 50 mm)	6 to 20" (150 to 500 mm)	16 to 30" (400 to 760 mm) Consult Panametrics for larger pipes.
Clamping Fixture	CFG-VI, CFG-V4	CFT-V8, CFT-VI2, CFT-PI	
Operating Frequency	1.0 MHz	500 kHz	200 kHz
Electrical Rating	200 V peak-to-peak, 5 mA		
Ambient Temperature Range	<i>North America: -20 to +75°C (-4 to +167°F)</i> <i>Europe: -40 to +75°C (-40 to +167°F)</i>		
Process Temperature Range	<i>North American/European safe areas: -40 to 130°C (-40 to 266°F)</i> <i>ATEX/European hazardous areas: -40 to +75°C</i>		
North American Certification - Explosion proof	 Class I, Div 1, Group B, C, D C US		
European Certification - Flameproof	 II 2 G Ex d mb IIC T6 Gb II 2 D Ex mb tb IIIC T80 °C Db Tamb -40 to 75°C (-40 to 167°F) KEMA 02ATEX2337 X		
North American Certification - Weatherproof	 IP66, TYPE 4X 200Vpp, 5mA C US		
European Certification - Weatherproof	IP 66 		
Note: <i>The transducer is protected by a suitable fuse located in the flowmeter electronics. The fuse has a rating corresponding with the short circuit current of the power supply.</i>			

1.8 Warranty

Each instrument manufactured by Panametrics is warranted to be free from defects in material and workmanship. Liability under this warranty is limited to restoring the instrument to normal operation or replacing the instrument, at the sole discretion of Panametrics. Fuses and batteries are specifically excluded from any liability. This warranty is effective from the date of delivery to the original purchaser. If Panametrics determines that the equipment was defective, the warranty period is:

- one year from delivery for electronic or mechanical failures
- one year from delivery for sensor shelf life

If Panametrics determines that the equipment was damaged by misuse, improper installation, the use of unauthorized replacement parts, or operating conditions outside the guidelines specified by Panametrics, the repairs are not covered under this warranty.

The warranties set forth herein are exclusive and are in lieu of all other warranties whether statutory, express or implied (including warranties or merchantability and fitness for a particular purpose, and warranties arising from course of dealing or usage or trade).

Return Policy

If a Panametrics instrument malfunctions within the warranty period, the following procedure must be completed:

1. Notify Panametrics, giving full details of the problem, and provide the model number and serial number of the instrument. If the nature of the problem indicates the need for factory service, Panametrics will issue a RETURN AUTHORIZATION NUMBER (RAN), and shipping instructions for the return of the instrument to a service center will be provided.
2. If Panametrics instructs you to send your instrument to a service center, it must be shipped prepaid to the authorized repair station indicated in the shipping instructions.
3. Upon receipt, Panametrics will evaluate the instrument to determine the cause of the malfunction.

Then, one of the following courses of action will then be taken:

- If the damage is covered under the terms of the warranty, the instrument will be repaired at no cost to the owner and returned.
- If Panametrics determines that the damage is not covered under the terms of the warranty, or if the warranty has expired, an estimate for the cost of the repairs at standard rates will be provided. Upon receipt of the owner's approval to proceed, the instrument will be repaired and returned.

Panometrics Measurement & Control Clamp-on Ultrasonic Flow Transducer Types C-RL, C-RS & C-RV

When installing this apparatus, the following requirements must be met:

- The certification covers the Panometrics clamp-on transducers fitted with an IME 7080 series enclosure (an Ex d & tb approved metal enclosure) and a clamping fixture, the assembly complying with the requirements of EN 60079-1 and EN 60079-31, and providing a degree of protection of IP6X. The following standards have been applied: EN60079-0:2009, EN60079-1:2007, EN60079-18: 2009 & EN 60079-31: 2009.
- This apparatus is equipment category 2 / EPL Gb & Db and may be installed in zone 1 and 2 areas. It may not be used in a zone 0 area. This apparatus is certified for gas and dust hazards.
- The apparatus certification is valid for the ambient and process temperature range combinations listed on the following page. This is not the operational temperature range of the apparatus - check supplied documentation for operational limits.
- Field wiring and cable entry fittings shall be rated at least 10° above ambient. Cable entries are 3/4" NPT, see product markings. ATEX approved (Ex d IIC and/or Ex tb IIIC) cable entry devices, appropriately rated, are required. These must be installed according to the manufacturer's instructions. Unused entries must be closed with an approved (Ex d IIC and/or Ex tb IIIC) plug. Connecting cables shall be mounted securely and protected from mechanical damage, pulling and twisting.
- The product contains no exposed parts which produce high surface temperatures or infrared, electromagnetic or ionizing radiation. The product must not be subjected to mechanical or thermal stresses in excess of those permitted in the certification documentation and the instruction manual. The metal part of the transducer body and the enclosure shall not be insulated.
- There are no internal sources of ignition in normal operation.
- The product is a hazardous area electrical apparatus and must be installed in accordance with the requirements of the product certification. The installation must be carried out in accordance with all the appropriate international, national and local regulations, codes of practice and site requirements for hazardous area apparatus and in accordance with the instructions contained in the manual. The installation shall comply with IEC / EN 60079-14.
- To avoid an ignition hazard, protect the transducer from impact or friction. In particular, the transducer must be installed so that the face of the transducer is towards the process, protecting the face from impact.
- The apparatus must be securely attached to the site of the flow measurement. The transducer assembly must be attached to the pipe as detailed in the user manual. For horizontal pipe runs, the transducers shall be mounted in the horizontal plane. The transducer shall not be mounted on top of the pipe. All NPT joints shall be made up wrench tight, suggested minimum torque is 40 lbf-ft / 54 N.m. Before installation, check that the transducer and enclosure are firmly locked together. Measures must be taken to ensure a good electrical contact and to prevent the threads from self-loosening. An inspection of the joint should be added to the routine maintenance schedule.
- To avoid electrical shock, the transducer must be mounted to a metal, electrically grounded, pipe system.
- A cable lug shall be used for all connections to the enclosure's earth points.
- Each enclosure cover is fitted with a locking device. This device must be loosened before opening the cover. It must be tightened after the cover is replaced so as to preserve the protection provided by the enclosure. Access to the circuitry must not be made during operation; the apparatus should be de-energized before opening. Modifications to the flameproof enclosure are not permitted.
- Only trained, competent personnel may install, operate and maintain the equipment. The product cannot be repaired by the user; it must be replaced by an equivalent certified product. Repairs should only be carried out by the manufacturer or by an approved repairer.

Special Conditions for Safe Use

- To avoid an ignition hazard, protect the transducer from impact or friction. In particular, the transducer must be installed so that the face of the transducer is towards the process, protecting the face from impact.
- The transducer must be protected by limiting the maximum fault current. This is achieved by operating the apparatus in conjunction with the following meters: XMT868(i), DF868, AT868, CG868 or CTF878. Only these meters are permitted under the certificate detailed below.

- The prospective short circuit current (PSCC) will not exceed 20mA. No power is dissipated internally when there is a short circuit.
- The connecting cable shall be secured close to the enclosure to prevent loosening and twisting.
- The mounting hardware shall not contain more than 7.5% Magnesium, Titanium or Zirconium.
- The assembly shall not be insulated beyond the plastic-to-metal joint on the transducer body. The assembly shall not be mounted on the top surface of a pipe or duct.

EU / EEA Installation Compliance

The use of this apparatus is subject to the EU directive on minimum requirements for improving the safety and health protection of workers potentially at risk from explosive atmospheres, Council Directive 1999/92/EC. The installer is required to be familiar with this document or the National transposing legislation.

C-Rx Transducer Assembly Details

Manufacturer and certificate owner:	Panometrics Infrastructure Sensing Inc., Billerica, MA 01821, USA.
Alternative manufacturing site:	Panometrics EMEA, Shannon, Co. Clare, Ireland
QAN License Number:	0794 (USA) or 0795 (Ireland)
Notified Body for Quality Assurance:	SGS Baseefa
Notified Body Number:	1180
Certificate Number:	KEMA 02ATEX2337 X
Apparatus Markings (see example below):	II 2 G Ex d mb IIC T6 Gb; II 2 D Ex mb tb IIIC T80°C Db
Ambient temperature range (ATEX):	-40°C to +75°C
Pipe surface temperature range (ATEX):	-40°C to +75°C

The manufacturing date is encoded in the transducer's serial number; The serial number format (see label below) is: **MMYYNNNN**, where **MMYY** is the month and year of construction and **NNNN** is a sequential number.

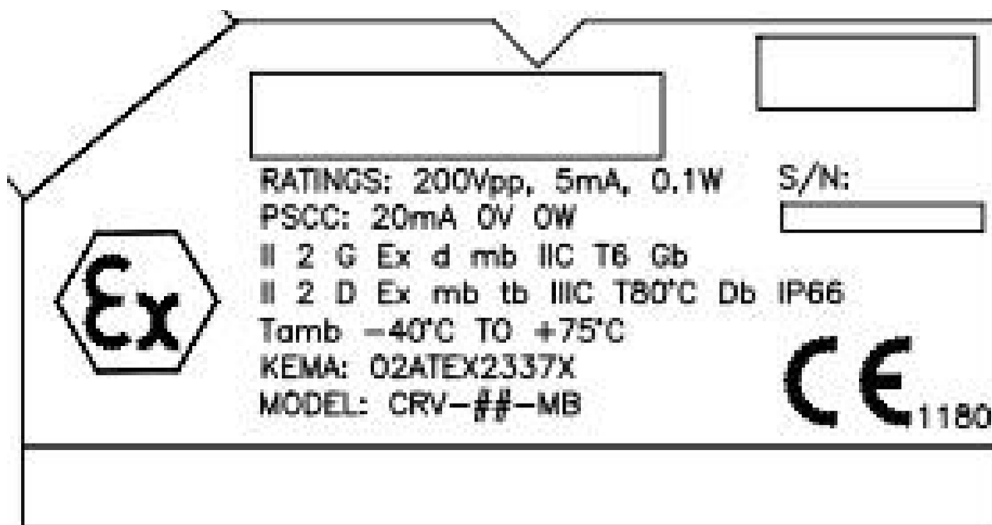

Customer Support Centers

U.S.A.

The Boston Center
1100 Technology Park Drive
Billerica, MA 01821

U.S.A.

Tel: 800 833 9438 (toll-free)
978 437 1000

E-mail: mstechsupport@bakerhughes.com

Ireland

Sensing House
Shannon Free Zone East
Shannon, County Clare
Ireland

Tel: +353 61 61470200

E-mail: mstechsupport@bakerhughes.com

Copyright 2021 Baker Hughes company.

This material contains one or more registered trademarks of Baker Hughes Company and its subsidiaries in one or more countries. All third-party product and company names are trademarks of their respective holders.

916-062 B

Baker Hughes 