

# Rosemount 285 Annubar<sup>®</sup> Primary Element Series

- *Designed for general purpose applications*
- *Increased plant uptime with the maintenance-free design*
- *Energy savings gained through minimal permanent pressure loss*
- *Industry leading integrated DP flowmeters are created when Annubar Averaging Pitot Tube (APT) primary elements are packaged with Rosemount pressure transmitters*

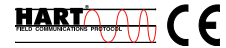

## Contents

The 285 Annubar Primary Element Series . . . . .	page 2
285 Annubar Primary Element Series Selection Guide. . . . .	page 3
Rosemount 285 Annubar Primary . . . . .	page 4
Dimensional Drawings. . . . .	page 6
Configuration Data Sheet (CDS). . . . .	page 12
Fluid Data Sheet (FDS). . . . .	page 15

# Rosemount 285 Annubar Primary Element

## The 285 Annubar Primary Element Series

### Designed for general purpose applications

The *Annubar's* revolutionary shape with sensing holes, promises the best accuracy and repeatability in applications with low to medium pressure and temperature requirements.

### Plant uptime is increased with the maintenance-free design

The *Annubar* sensor is designed to prevent wear and blockage in the pipe. The electronics are the most stable in the industry and allows up to 10 year calibration cycles, providing significant maintenance savings.

### Energy savings gained through minimal permanent pressure loss

The non-constricting design of the *Annubar* sensor creates minimal blockage in the pipe, which reduces permanent pressure loss. Permanent pressure loss can be converted directly into energy savings in the form of compressor cost for gas, electrical cost for pumping liquids, and fuel costs for generating steam.

### Industry leading integrated DP flowmeters

By integrating pressure transmitter electronics with the *Annubar*, Rosemount provides the highest performing insertion DP flowmeter. This fully integrated flowmeter eliminates the need for instrument fittings, tubing, valves, adapters, manifolds, and mounting brackets, thereby reducing welding and installation time.

**Integral mount head allows close coupling to most Rosemount transmitters which provides flowmeter capabilities.**



### Advanced *PlantWeb*® Functionality



Rosemount *Annubar* flowmeters power *PlantWeb* through a scalable architecture, advanced diagnostics, and MultiVariable capabilities. This reduces operational and maintenance expenditures while improving throughput and utilities management.

## Rosemount DP Flow Solutions

### Annubar Flowmeter Series: Rosemount 3051SFA, 3095MFA, 485, and 285

The state-of-the-art, fifth generation Rosemount 485 Annubar combined with the 3051S or 3095MV MultiVariable transmitter creates an accurate, repeatable and dependable insertion-type flowmeter. The Rosemount 285 provides a commercial product offering for your general purpose applications.

### Compact Orifice Flowmeter Series: Rosemount 3051SFC, 3095MFC, and 405

Compact Orifice Flowmeters can be installed between existing flanges, up to a Class 600 (PN100) rating. In tight fit applications, a conditioning orifice plate version is available, requiring only two diameters of straight run upstream.

### Integral Orifice Flowmeter Series: Rosemount 3051SFP, 3095MFP, and 1195

These integral orifice flowmeters eliminate the inaccuracies that become more pronounced in small orifice line installations. The completely assembled, ready to install flowmeters reduce cost and simplify installation.

### Orifice Plate Primary Element Systems: Rosemount 1495 and 1595 Orifice Plates, 1496 Flange Unions and 1497 Meter Sections

A comprehensive offering of orifice plates, flange unions and meter sections that is easy to specify and order. The 1595 Conditioning Orifice provides superior performance in tight fit applications.

## 285 Annubar Primary Element Series Selection Guide

### Rosemount 285 Annubar with Pak-Lok Mounting

- Designed to give the highest performance in applications with low to medium pressure and temperature requirements
- Innovative T-shape design provides accuracy to  $\pm 1.00\%$
- Optional integral manifold head allows direct mounting of DP transmitters
- Ideal fluid type: liquid, gas, and steam

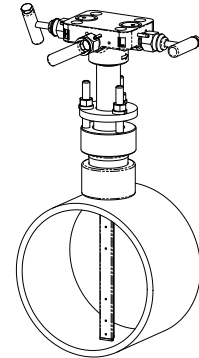

**Rosemount 285 Annubar with Pak-Lok Mounting**

### Rosemount 285 Annubar with Duct Mount (No compression fitting)

- Combines the 285 Annubar technology with duct mounting installation
- For applications requiring duct mounting installation
- Ideal fluid types: gas
- Threaded stud for opposite side support

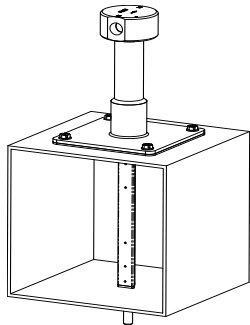

**Rosemount 285 Annubar with Duct Mount**

### Rosemount 285 Annubar with Duct Mount Compression Fitting

- For application in ducts requiring additional mounting support
- Ideal fluid types: gas
- No opposite side support required

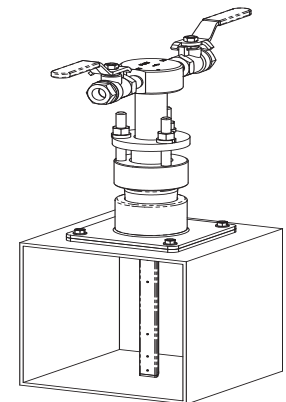

**Rosemount 285 Annubar with Duct Mount Compression Fitting**

# Rosemount 285 Annubar Primary Element

## Rosemount 285 Annubar Primary

### SPECIFICATIONS

#### Performance

##### Performance Statement Assumptions

Measured pipe I.D.

##### Discharge Coefficient Factor

Liquid:  $\pm 1.0\%$  of flow rate

Gas and Steam:  $\pm 2.0\%$  of flow rate

##### Repeatability

$\pm 0.1\%$

##### Line Sizes

- Sensor Size 1: 2-in. to 8-in. (50 to 200 mm)
- Sensor Size 2: 8-in. and above  
For larger line sizes, consult factory.

### NOTE

Some mounting styles not available in large line sizes.

TABLE 1. Reynolds Number and Probe Width

Sensor Size	Minimum Rod Reynolds Number ( $R_d$ )	Probe Width ( $d$ ) (inches)
1	6500	0.590-in. (14.99 mm)
2	12500	1.060-in. (26.92 mm)

Where

$d$  = Probe width (feet)

$v$  = Velocity of fluid (ft/sec)

$\rho$  = Density of fluid (lbm/ft<sup>3</sup>)

$\mu$  = Viscosity of the fluid (lbm/ft-sec)

$$R_d = \frac{d \times v \times \rho}{\mu}$$

#### Sizing

Contact an Emerson Process Management representative for assistance. A Configuration Data Sheet is required prior to order for application verification.

#### Flow Turndown

10:1 or better

#### Functional

##### Service

- Liquid
- Gas
- Steam (limited)

##### Temperature Limits<sup>(1)</sup>

- -40 to 300°F (-40 to 149°C)
- -40 to 850°F (-40 to 454°C) for Duct Mount Version (D1) only

##### Pressure Limits<sup>(1)</sup>

- Pak-Lok: 150# ANSI (275 psig at 100 °F (19 bar at 38 °C))
- Duct Mount (D1 & D2): 10 PSIG (0.6 bar)

##### Pressure and Temperature Limits

Direct Mount Electronics

- Up to 150# ANSI (275 psig at 100 °F (19 bar at 38 °C))
- Maximum temperature: 500 °F (260 °C)
- Integral temperature measurement is not available.

Remote Mount Electronics

- Up to 150# ANSI (275 psig at 100 °F (19 bar at 38 °C)).
- Integral temperature measurement is not available.

#### Physical

##### Annubar Sensor Material

- 316 Stainless Steel

##### Pak-Lok

See "Dimensional Drawings" on page 6

Pak-Lok Model (option P1)

- Provided with a compression sealing mechanism rated up to 150# ANSI (275 psig at 100 °F (19 bar at 38 °C))
- PTFE Packing (-40 to 300 °F (-40 to 149 °C))

##### Duct Mount

See "Dimensional Drawings" on page 7.

Duct Mount without Compression Fitting Model (option D1)

- Provided with duct mounting rated up to 10 psig at 850°F (0.6 bar at 454°C).

##### Duct Mount with Compression Fitting

See "Dimensional Drawings" on page 8.

Duct Mount with Compression Fitting Model (option D2)

- Provided with duct mount compression fitting rated up to 10 psig at 300°F (0.6 bar at 38°C).

#### Instrument Connections Temperature Ranges

TABLE 2. Minimum / Maximum Temperature Range

Code	Description	Temperature
G1	Needle Valves, Carbon Steel	-40 to 500°F (-40 to 260°C)
G2	Needle Valves, Stainless Steel	-40 to 500°F (-40 to 260°C)
B1	Ball Valve, Carbon Steel	-40 to 300°F (-40 to 149°C)
B2	Ball Valve, Stainless Steel	-40 to 300°F (-40 to 149°C)

(1) Annubar option selections may effect pressure and temperature limitations.

## Installation Considerations

### Straight Run Requirements<sup>(1)</sup>

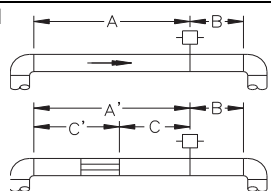
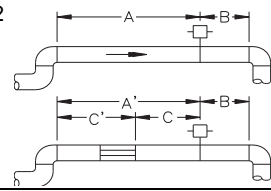
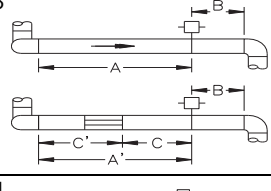
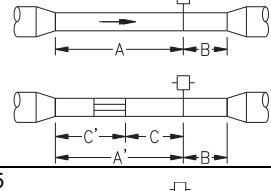
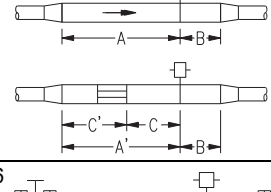
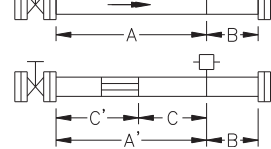
	In Plane		Upstream Dimensions (Pipe Diameters)					Downstream
	Out of Plane		Without Vanes <sup>(2)</sup>		With Vanes <sup>(3)</sup>			
	In Plane A	Out of Plane A	A'	C	C'	B		
1		8	10	—	—	—	4	
2		11	16	—	—	—	4	
3		23	28	—	—	—	4	
4		12	12	—	—	—	4	
5		18	18	—	—	—	4	
6		30	30	—	—	—	4	

- Consult the factory for instructions regarding use in square or rectangular ducts.
- "In Plane A" means the bar is in the same plane as the elbow. "Out of Plane A" means the bar is perpendicular to the plane of the upstream elbow.
- Use straightening vane to reduce the required straight run length.

### Flowmeter Orientation (Recommended)

#### Gas (Horizontal)

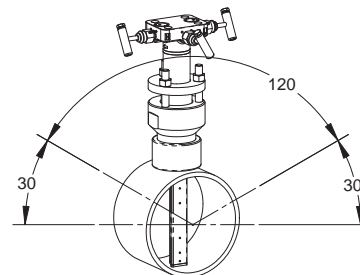

#### Liquid and Steam (Horizontal)

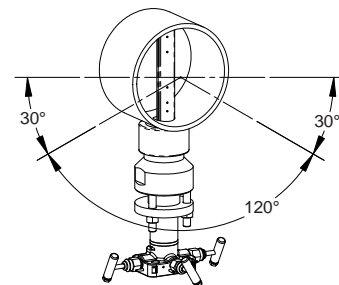

#### Gas (Vertical)

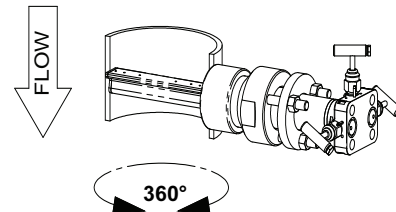

Note: Can also be mounted for Gas Vertical up applications.

#### Steam (Vertical)

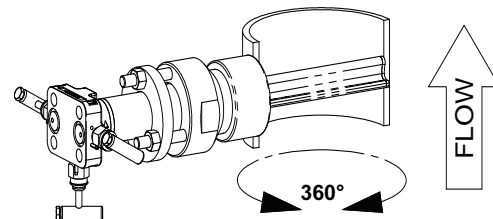

### Drill Hole Size According to Sensor Size

Sensor Size	Diameter
1	3/4-in. (19 mm)
2	1 5/16-in. (34 mm)

## Dimensional Drawings

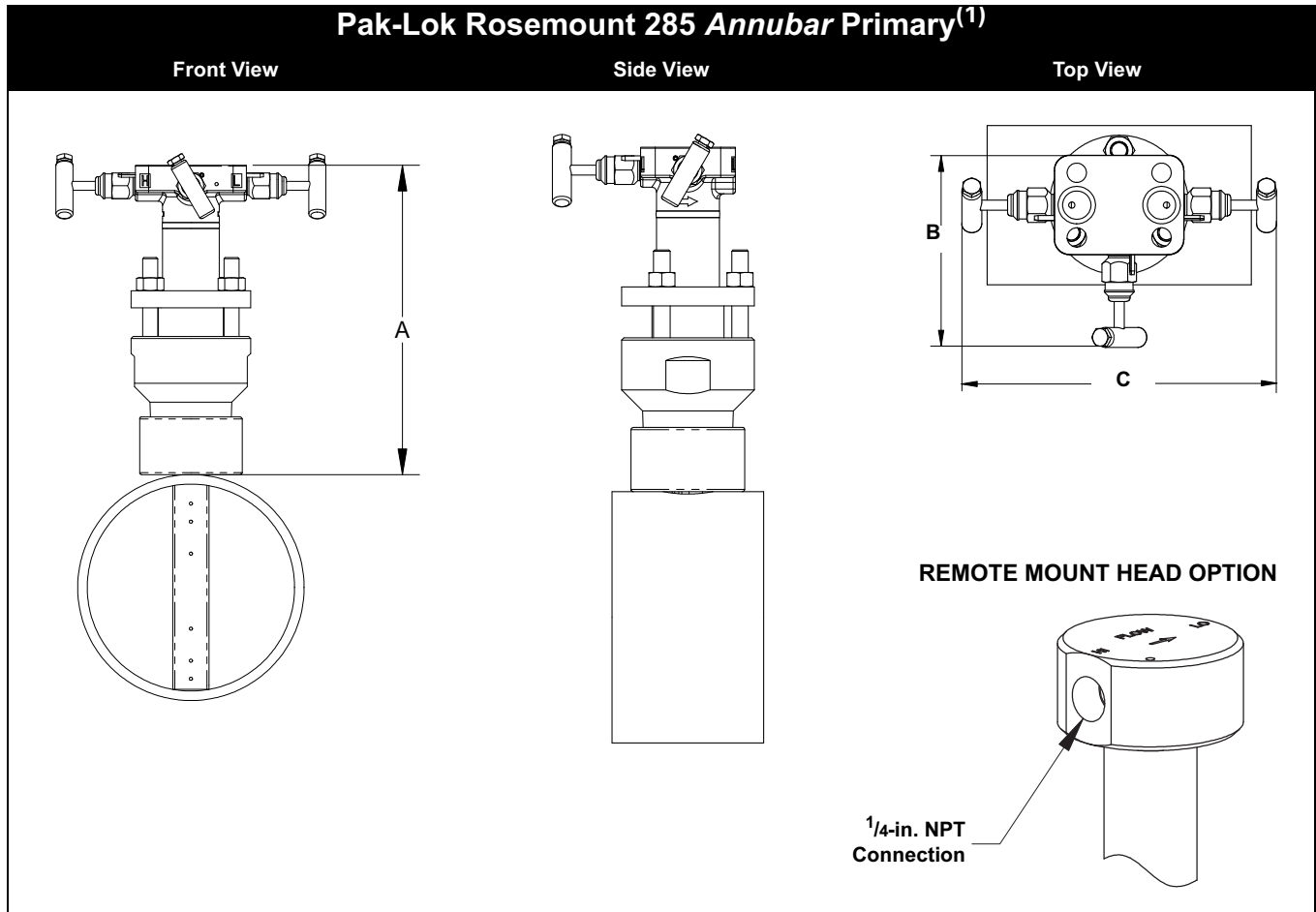

(1) The Pak-Lok Annubar model is available up to 150# ANSI (275 psig at 100 °F (19 bar at 38 °C)).

TABLE 3. Rosemount 285 Annubar Primary - Pak-Lok

Sensor Size	A (Max)	B (Max)	C (Max)
1	8.50 (215.9)	5.00 (127.0)	9.00 (228.6)
2	11.00 (279.4)	5.00 (127.0)	9.00 (228.6)

*Dimensions are in inches (millimeters)*

## Dimensional Drawings (continued)

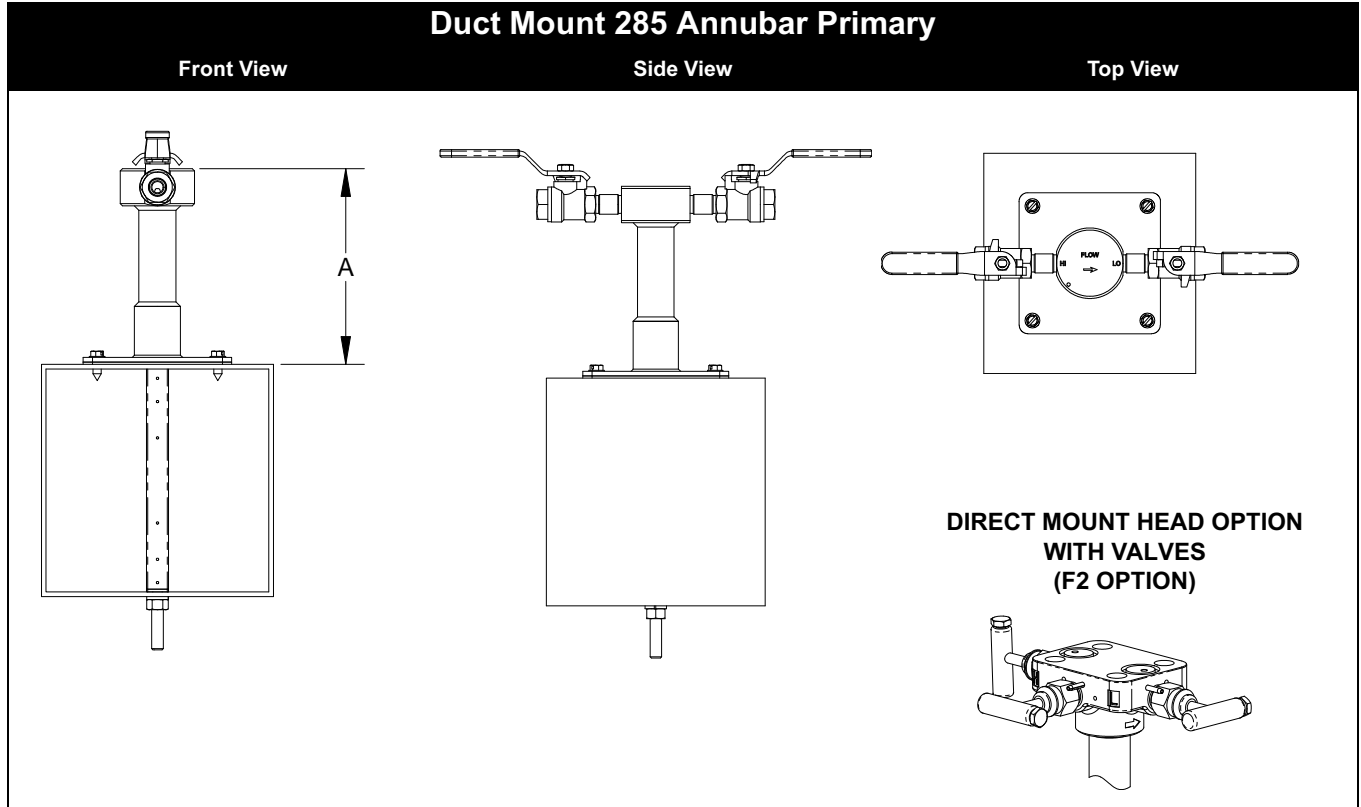

TABLE 4. Rosemount 285 Annubar with Duct Mount

Sensor Size	A (Max)
1	7.00 (177.8)
2	9.00 (228.6)

*Dimensions are in inches (millimeters)*

# Rosemount 285 Annubar Primary Element

## Dimensional Drawings (continued)

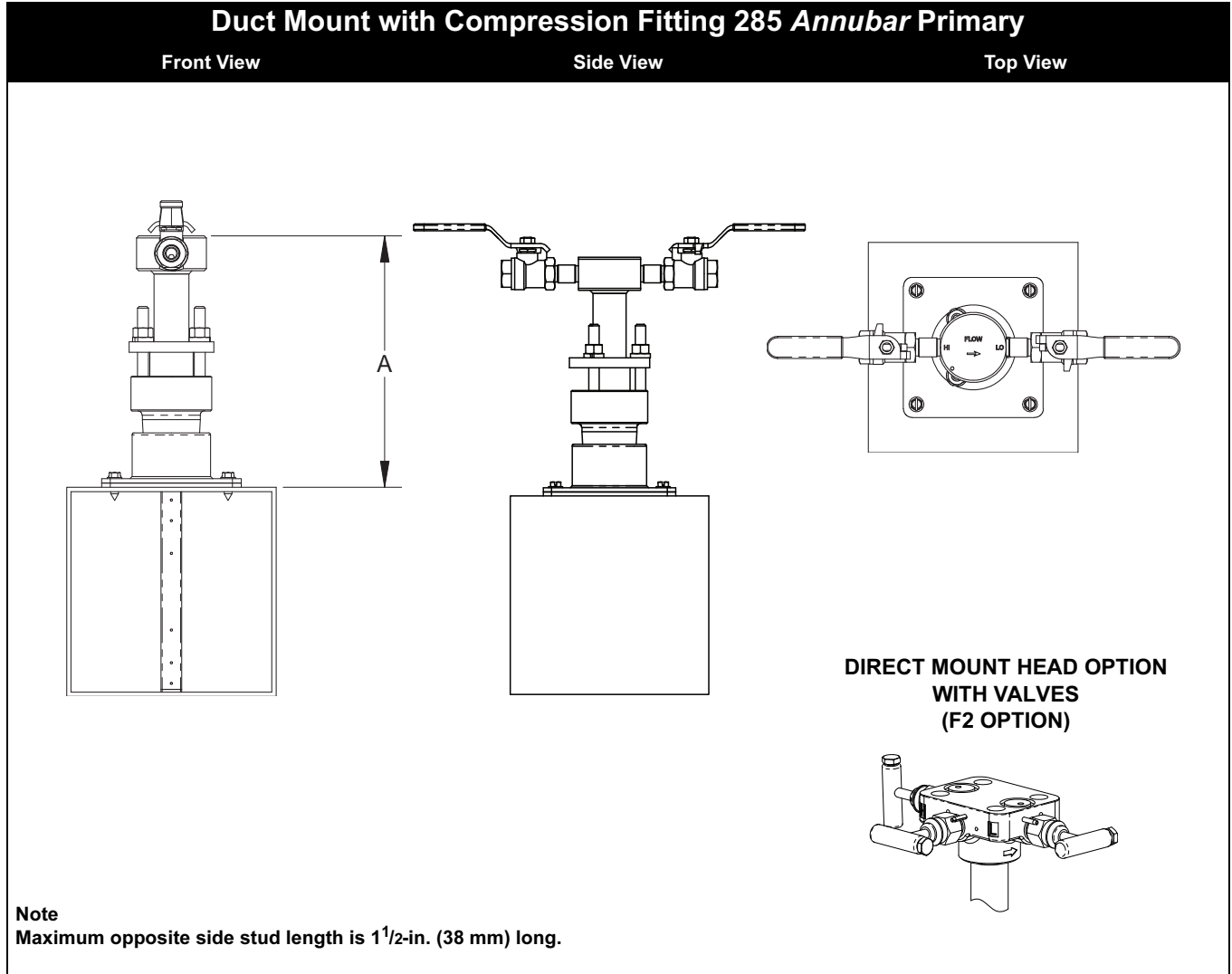

TABLE 5. Duct Mount with Compression Fitting

Sensor Size	A (Max)
1	8.50 (215.9)
2	11.00 (279.4)

*Dimensions are in inches (millimeters)*



## ORDERING INFORMATION

### Rosemount 285 Annubar Primary Ordering Information

Model	Annubar Primary Element
285	Economy Annubar
Code	Fluid Type
L	Liquid
G	Gas
S	Steam
Code	Line Size
020	2-in. (50 mm)
025	2 <sup>1</sup> / <sub>2</sub> -in. (63.5 mm)
030	3-in. (80 mm)
035	3 <sup>1</sup> / <sub>2</sub> -in. (89 mm)
040	4-in. (100 mm)
050	5-in. (125 mm)
060	6-in. (150 mm)
080	8-in. (200 mm)
100	10-in. (250 mm)
120	12-in. (300 mm)
140	14-in. (350 mm)
160	16-in. (400 mm)
180	18-in. (450 mm)
200	20-in. (500 mm)
240	24-in. (600 mm)
300	30-in. (750 mm)
360	36-in. (900 mm)
420	42-in. (1066 mm)
480	48-in. (1210 mm)
600	60-in. (1520 mm)
720	72-in. (1820 mm)
780	78-in. (1950 mm)
840	84-in. (2100 mm)
900	90-in. (2250 mm)
960	96-in. (2400 mm)
Code	Pipe I.D. Range (Refer to Pipe ID Range Table for Code)
A	Range A from the Pipe I.D. table
B	Range B from the Pipe I.D. table
C	Range C from the Pipe I.D. table
D	Range D from the Pipe I.D. table
E	Range E from the Pipe I.D. table
Z	Non-standard Pipe I.D. Range or Line Sizes greater than 12 inches (sensor size 2) or greater than 8 inches (sensor size 1).
Code	Piping Configuration
C	Circular
R	Rectangular or Square
Code	Pipe Material/Mounting Assembly Material
C	Carbon Steel
S	316 Stainless Steel
0	No Mounting (Customer Supplied)
Code	Annubar Type
P1	Pak-Lok
D1	Duct Mount Plate without Compression Fitting
D2	Duct Mount Plate with Compression Fitting

**Continued on Next Page**

# Rosemount 285 Annubar Primary Element

Code	Sensor Material
S	316 Stainless Steel
Code	Sensor Size
1	Sensor Size 1
2	Sensor Size 2
Code	Electronics Connection Platform
3	Direct-mount
7	Remote-mount NPT Connections
Code	Options
<b>Instrument Connections for Remote Mount Option</b>	
G1	Needle Valves, CS
G2	Needle Valves, SS
B1	Ball Valves, CS
B2	Ball Valves, SS
<b>Variable Mount Height</b>	
VM	Variable Mounting Height for Customer Supplied Mounting
<b>Attach To</b>	
H1	Attach to Transmitter
<b>Manifold</b>	
F2 <sup>(1)</sup>	3-Valve Manifold, SST
<b>Special Inspection<sup>(2)</sup></b>	
QC1	Visual and Dimensional Inspection w/Cert
QC7	Inspection and Performance Certificate
<b>Material Traceability Certification <sup>(1)</sup></b>	
Q8	Material Cert per ISO 10474 3.1.B and EN 10204 3.1.B
<b>Special Shipment</b>	
Y1	Mounting Hardware Shipped Separately

(1) Applies to 285 Primary Element only. If F2 option is ordered with Electronic Connections Platform Code '3' (Direct Mount), manifold is integral to head. If F2 is ordered with Code '7' (Remote Mount), the manifold is supplied loose.

(2) Applies to 285 Primary Element Only.

## Pipe I.D. Range Code—measured in inches (millimeters)

See "Rosemount 285 Annubar Primary Ordering Information" on page 9

For pipes with an Inner Diameter (I.D.) Range / Pipe Wall Thickness not found in this table or with a line size greater than 12-in. (300 mm), choose option code Z and specify the exact pipe dimensions (I.D. and Pipe Wall Thickness) on the "" on page 11. The Emerson process Management sizing program will determine this code, based on the application piping.

	Line Size			Pipe Wall Thickness		I.D. Range Code	
	Nominal	Max. O.D.	Option Code	ANSI Pipes	Non-ANSI Pipes		
Sensor Size 1	2-in. (50 mm)	2.625-in. (66.68 mm)	020	1.784 to 1.841-in. (45.31 to 46.76 mm)	0.065 to 0.488-in. (1.7 to 12.4 mm)	A	
				1.842 to 1.938-in. (46.79 to 49.23 mm)	0.065 to 0.545-in. (1.7 to 13.8 mm)	B	
				1.939 to 2.067-in. (49.25 to 52.50 mm)	0.065 to 0.417-in. (1.7 to 10.6 mm)	C	
				2.068 to 2.206-in. (52.53 to 56.03 mm)	0.065 to 0.407-in. (1.7 to 10.3 mm)	D	
				2.207 to 2.322-in. (56.06 to 58.98 mm)	0.083 to 0.448-in. (2.1 to 11.4 mm)	B	
	2 1/2-in. (63.5 mm)	3.188-in. (80.98 mm)	025	2.323 to 2.469-in. (59.00 to 62.71 mm)	0.083 to 0.563-in. (2.1 to 14.3 mm)	0.083 to 0.417-in. (2.1 to 10.6 mm)	C
				2.470 to 2.598-in. (62.74 to 65.99 mm)		0.083 to 0.435-in. (2.1 to 11.0 mm)	D
				2.599 to 2.647-in. (66.01 to 67.23 mm)		0.083 to 0.515-in. (2.1 to 13.1 mm)	E
				2.648 to 2.751-in. (67.26 to 69.88 mm)		0.083 to 0.460-in. (2.1 to 11.7 mm)	A
	3-in. (80 mm)	3.75-in. (95.25 mm)	030	2.752 to 2.899-in. (69.90 to 73.63 mm)	0.083 to 0.563-in. (2.1 to 14.3 mm)	0.083 to 0.416-in. (2.1 to 10.6 mm)	B
				2.900 to 3.068-in. (73.66 to 77.93 mm)		0.083 to 0.395-in. (2.1 to 10.0 mm)	C
				3.069 to 3.228-in. (77.95 to 81.99 mm)		0.083 to 0.404-in. (2.1 to 10.3 mm)	D
				3.229 to 3.333-in. (82.02 to 84.66 mm)		0.120 to 0.496-in. (3.0 to 12.6 mm)	B
	3 1/2-in. (89 mm)	4.25-in. (107.95 mm)	035	3.334 to 3.548-in. (84.68 to 90.12 mm)	0.120 to 0.600-in. (3.0 to 15.2 mm)	0.120 to 0.386-in. (3.0 to 9.8 mm)	C
				3.549 to 3.734-in. (90.14 to 94.84 mm)		0.120 to 0.415-in. (3.0 to 10.5 mm)	D
				3.735 to 3.825-in. (94.87 to 97.16 mm)		0.120 to 0.510-in. (3.0 to 13.0 mm)	B
				3.826 to 4.026-in. (97.18 to 102.26 mm)	0.120 to 0.600-in. (3.0 to 15.2 mm)	0.120 to 0.400-in. (3.0 to 10.2 mm)	C
	4-in. (100 mm)	5.032-in. (127.81 mm)	040	4.027 to 4.237-in. (102.29 to 107.62 mm)		0.120 to 0.390-in. (3.0 to 9.9 mm)	D
				4.238 to 4.437-in. (107.65 to 112.70 mm)		0.120 to 0.401-in. (3.0 to 10.2 mm)	E
				4.438 to 4.571-in. (112.73 to 116.10 mm)		0.134 to 0.481-in. (3.4 to 12.2 mm)	A
				4.572 to 4.812-in. (116.13 to 122.22 mm)	0.134 to 0.614-in. (3.4 to 15.6 mm)	0.134 to 0.374-in. (3.4 to 9.5 mm)	B
	5-in. (125 mm)	6.094-in. (154.79 mm)	050	4.813 to 5.047-in. (122.25 to 128.19 mm)		0.134 to 0.380-in. (3.4 to 9.7 mm)	C
				5.048 to 5.249-in. (128.22 to 133.32 mm)		0.134 to 0.413-in. (3.4 to 10.5 mm)	D
				5.250 to 5.472-in. (133.35 to 138.99 mm)		0.134 to 0.392-in. (3.4 to 9.9 mm)	A
5.473 to 5.760-in. (139.01 to 146.30 mm)				0.134 to 0.614-in. (3.4 to 15.6 mm)	0.134 to 0.327-in. (3.4 to 8.3 mm)	B	
6-in. (150 mm)	6.93-in. (176.02 mm)	060	5.761 to 6.065-in. (146.33 to 154.05 mm)		0.134 to 0.310-in. (3.4 to 7.9 mm)	C	
			6.066 to 6.383-in. (154.08 to 162.13 mm)		0.134 to 0.297-in. (3.4 to 7.5 mm)	D	
			6.384 to 6.624-in. (162.16 to 168.18 mm)		0.250 to 0.499-in. (6.4 to 12.6 mm)	B	
			6.625 to 7.393-in. (168.21 to 187.78 mm)	0.250 to 0.73-in. (6.4 to 18.5 mm)	0.250 to 0.374-in. (6.4 to 9.5 mm)	C	
8-in. (200 mm)	9.688-in. (246.08 mm)	080	7.394 to 7.624-in. (187.78 to 193.65 mm)		0.250 to 0.312-in. (6.4 to 7.9 mm)	D	
			7.625 to 7.981-in. (193.68 to 202.72 mm)		0.250 to 0.364-in. (6.4 to 9.2 mm)	E	
			7.982 to 8.400-in. (202.74 to 213.36 mm)		0.250 to 1.239-in. (6.4 to 31.4 mm)	B	
			8.401 to 8.766-in. (213.39 to 222.66 mm)	0.250 to 1.47-in. (6.4 to 37.3 mm)	0.250 to 1.114-in. (6.4 to 28.3 mm)	C	
8-in. (200 mm)	9.688-in. (246.08 mm)	080	7.982 to 8.400-in. (202.74 to 213.36 mm)		0.250 to 1.052-in. (6.4 to 26.7 mm)	D	
			8.401 to 8.766-in. (213.39 to 222.66 mm)		0.250 to 1.104-in. (6.4 to 28.0 mm)	E	
			8.767 to 9.172-in. (222.68 to 232.97 mm)		0.250 to 1.065-in. (6.4 to 27.1 mm)	A	
			9.173 to 9.561-in. (232.99 to 242.85 mm)	0.250 to 1.470-in. (6.4 to 37.3 mm)	0.250 to 1.082-in. (6.4 to 27.5 mm)	B	
10-in. (250 mm)	11.75-in. (298.45 mm)	100	9.562 to 10.020-in. (242.87 to 254.51 mm)		0.250 to 1.012-in. (6.4 to 25.7 mm)	C	
			10.021 to 10.546-in. (254.53 to 267.87 mm)		0.250 to 0.945-in. (6.4 to 24.0 mm)	D	
			10.547 to 10.999-in. (267.89 to 279.37 mm)		0.250 to 1.018-in. (6.4 to 25.9 mm)	E	
			11.000 to 11.373-in. (279.40 to 288.87 mm)	0.250 to 1.470-in. (6.4 to 37.3 mm)	0.250 to 1.097-in. (6.4 to 27.9 mm)	B	
12-in. (300 mm)	13.0375-in. (331.15 mm)	120	11.374 to 11.938-in. (288.90 to 303.23 mm)		0.250 to 0.906-in. (6.4 to 23.0 mm)	C	
			11.939 to 12.250-in. (303.25 to 311.15 mm)		0.250 to 1.159-in. (6.4 to 29.4 mm)	D	
						D	

# Rosemount 285 Annubar Primary Element

## Configuration Data Sheet (CDS)

### DP FLOW CDS

Complete this form to define a custom flow configuration for DP Flowmeters. Unless specified, the flowmeter will be shipped with the default values identified by the H symbol.

For technical assistance in filling out this CDS, call a Rosemount representative.

#### NOTE

Any missing information will be processed with the indicated default values.

\* = Required Item

★ = Default

#### Customer Information

Customer:	Contact Name:
Customer Phone:	Customer Fax:
Customer Approval Sign-Off:	Customer PO:

#### Calculation Approval

Check this box if a calculation for approval prior to manufacturing is required

#### Application and Configuration Data Sheet (Required with Order)

Tag:

Model No <sup>(1)</sup>

\* **Select fluid type**       Liquid       Gas       Steam

\* **Fluid name<sup>(2)</sup>**

#### Flowmeter Information (optional)

\* Failure Mode Alarm Direction (select one)       Alarm High★       Alarm Low

Software Tag: \_\_\_\_\_ (8 characters)

Descriptor: \_\_\_\_\_ (16 characters)

Message: \_\_\_\_\_  
 \_\_\_\_\_ (32 characters)

Date:                      Day \_\_\_ (numeric)                      Month \_\_\_ (numeric)                      Year \_\_\_ (numeric)

(1) A complete model number is required before Rosemount Inc. can process the order.  
 (2) If the Fluid is not located in Table 6 on page 14, the "" on page 11 must be completed.

#### For Rosemount Use Only

S.O.:	LI
CHAMP:	DATE:
	ADMIN:

\* = Required Item  
 ★ = Default

**Primary Element Information**

\* Select Differential Producer (Select One)

**Annubar**

- 485 Annubar/ 3095MFA Mass ProBar, 3051SFA ProBar
- 285 Annubar Primary Element Series
- Annubar Diamond II + / Mass Probar
- Long Radius Wall Taps, ASME
- Long Radius Wall Taps, ISO
- ISA 1932, ISO

**Venturi**

- Nozzle, ISO
- Rough Cast/Fabricated Inlet, ASME
- Round Cast Inlet, ISO
- Machined Inlet, ASME
- Machined Inlet, ISO
- Welded Inlet, ISO

**Other (All options require a discharge coefficient value)**

- Calibrated Orifice: Flange, Corner, or D & D/2 Taps.

- Discharge coefficient: \_\_\_\_\_
- Calibrated Orifice: 2<sup>1</sup>/<sub>2</sub> D & 8D Taps
- Discharge coefficient: \_\_\_\_\_
- Calibrating Nozzle
- Discharge coefficient: \_\_\_\_\_
- Calibrating Venturi
- Discharge coefficient: \_\_\_\_\_
- Area Averaging Meter
- Discharge coefficient: \_\_\_\_\_
- V-Cone®
- Discharge coefficient: \_\_\_\_\_

Diameter (d) \_\_\_\_\_  inch★      at \_\_\_\_\_  °F       °C  
 millimeters       68 °F★

Special Annubar dimension (required if customer supplies mounting hardware).       ODF \_\_\_\_\_       ODT \_\_\_\_\_

**Pipe Information**

\* Orientation / Flow Direction:     Vertical Up                       Vertical Down                       Horizontal

\* Line Size / Schedule: \_\_\_\_\_      Body I.D. (D): \_\_\_\_\_

**Materials of Construction**

\* Pipe Material                       Carbon Steel     304 SST     316 SST     Hastelloy     Other \_\_\_\_\_

\* Primary Element Material     316 SST     Hastelloy     Other \_\_\_\_\_ (Please verify material availability)

**Operating Conditions**

	4 mA value	Minimum	Normal	Maximum	Full Scale:20 mA flow rate (design to P and T)	Design
Flow Rate	0	*(1)	*	*		
Pressure (P)	—	*(1)	*	*(1)	*(2)	
Temperature (T)	—	*(1)	*	*(1)	*	

**RTD Mode**

Normal Mode ★ (Requires a RTD to be connected. If the RTD is disconnected or fails, the 3095MV output goes to alarm value)

Fixed Temperature Mode:    Specify the fixed temperature value \_\_\_\_\_  °F       °C

Backup Mode (Uses the connected RTD for temperature measurement. If the RTD is disconnected or fails, the transmitter uses a fixed temperature value as a backup. This will not cause the mA output to go to alarm value and can potentially cause inaccurate flow measurement.)    Fixed temperature value to be used as backup \_\_\_\_\_  °F       °C

# Rosemount 285 Annubar Primary Element

\* = Required Item

★ = Default

## Base Conditions

Standard Base (P=14.696 psia / 101.325 kPa abs, T= 60 °F (15.56 °C))

Normal Base (P=14.696 psia / 101.325 kPa abs, T= 32 °F (0 °C))

Standard Base for Natural Gas (AGA) (P=14.73 psia, T= 60°F (15.56 °C))

User Defined: P= \_\_\_\_\_ Units: \_\_\_\_\_ T= \_\_\_\_\_ Units = \_\_\_\_\_

Compressibility at Base: \_\_\_\_\_ OR Density at Base: \_\_\_\_\_

(1) Operating ranges for pressure and temperature are needed for transmitter configuration.

(2) Required to verify that the product selection meets design criteria.

TABLE 6. Rosemount Fluids Database<sup>(1)</sup>

Acetic Acid	Divinyl Ether	Methane	n-Hexane	1-Heptanol
Acetone	Ethane	Methanol	n-Octane	1-Heptene
Acetonitrile	Ethanol	Methyl Acrylate	n-Pentane	1-Hexene
Acetylene	Ethylamine	Methyl Ethyl Ketone	Oxygen	1-Hexadecanol
Acrylonitrile	Ethylbenzene	Methyl Vinyl Ether	Pentafluorothane	1-Octanol
Air	Ethylene	m-Chloronitrobenzene	Phenol	1-Octene
Allyl Alcohol	Ethylene	Neon	Propadiene	1-Nonanol
Ammonia	GlycolEthylene	Neopentane	Pyrene	1-Pentadecanol
Argon	Oxide	Nitric Acid	Propylene	1-Pentanol
Benzene	Fluorene	Nitric Oxide	Styrene	1-Pentene
Benzaldehyde	Furan	Nitrobenzene	Sulfur Dioxide	1-Undecanol
Benzyl Alcohol	Helium-4	m-Dichlorobenzene	Propane	1-Nonanal
Biphenyl	Hydrazine	Nitroethane	Toluene	1,2,4- Trichlorobenzene
Carbon Dioxide	Hydrogen	Nitrogen	Trichloroethylene	1,1,2- Trichloroethane
Carbon Monoxide	Hydrogen Chloride	Nitromethane	Vinyl Acetate	1,1,2,2- Tetrafluoroethane
Carbon Tetrachloride	Hydrogen Cyanide	Nitrous Oxide	Vinyl Chloride	1,2-Butadiene
Chlorine	Hydrogen Peroxide	n-Butane	Vinyl Cyclohexane	1,3-Butadiene
Chlorotrifluoroethylene	Hydrogen Sulfide	n-Butanol	Water	1,3,5- Trichlorobenzene
Chloroprene	Isobutane	n-Butyraldehyde	1-Butene	1,4-Dioxane
Cycloheptane	Isobutene	n-Butyronitrile	1-Decene	1,4-Hexadiene
Cyclohexane	Isobutyl benzene	n-Decane	1-Decanal	2-Methyl-1-Pentene
Cyclopentane	Isopentane	n-Dodecane	1-Decanol	2,2-Dimethylbutane
Cyclopentene	Isoprene	n-Heptadecane	1-Dodecene	
Cyclopropane	Isopropanol	n-Heptane	1-Dodecanol	

(1) This list is subject to change without notice. Steam per ASME Steam tables. All other fluids per AIChE.

## Drawing/Notes

---

## **Fluid Data Sheet (FDS)**

For custom fluid not in the Rosemount Fluid Database

For technical assistance in filling out this CDS, call an Emerson Process Management representative. Complete this form to define a custom fluid. The H symbol identifies the default value.

---

### **NOTE**

This form is not required if using the Rosemount Fluid Database.

---

\* = Required Item

★ = Default

#### **Customer Information**

Customer:	Contact Name:
Customer Phone:	Customer Fax:
	Customer PO:

#### **Fluid Properties**

<input type="checkbox"/> Custom Liquid– Complete Table	<input type="checkbox"/> Liquid
<input type="checkbox"/> Custom Gas– Complete Table	<input type="checkbox"/> Gas
<input type="checkbox"/> Custom Natural Gas– Complete Table	<input type="checkbox"/> Natural Gas

---

#### **For Rosemount Use Only**

S.O.:	LI
CHAMP:	DATE:
	ADMIN:

# Rosemount 285 Annubar Primary Element

**TABLE 7. Custom Liquid Worksheet**

\* = Required Item

★ = Default

**Mass Liquid Density and Viscosity Information**

1. Fill in the following operating temperatures

- a) \_\_\_\_\_ min
- b) \_\_\_\_\_ [ $^{1/3}(\text{max} - \text{min})$ ] + min
- c) \_\_\_\_\_ [ $^{2/3}(\text{max} - \text{min})$ ] + min
- d) \_\_\_\_\_ max

**2. Transfer the values from the above section to the numbered lines below.**

3. Check one Density box, then enter the values for each temperature and the standard density.

4. Check one Viscosity box, then enter values for each temperature. (At least one viscosity value is required).

Density

- Density in lbs/CuFt
- Density in kg/CuM

Viscosity

- Viscosity in centipoise
- Viscosity in lbs/ft sec
- Viscosity in pascal sec

Temperature

- a) \_\_\_\_\_ min
- b) \_\_\_\_\_ [ $^{1/3}(\text{max} - \text{min})$ ] + min
- c) \_\_\_\_\_ [ $^{2/3}(\text{max} - \text{min})$ ] + min
- d) \_\_\_\_\_ max

Temperature

- a) \_\_\_\_\_ min.
- b) \_\_\_\_\_ [ $^{1/3}(\text{max} - \text{min})$ ] + min
- c) \_\_\_\_\_ [ $^{2/3}(\text{max} - \text{min})$ ] + min
- d) \_\_\_\_\_ max

Base density: \_\_\_\_\_  
(at base reference conditions specified)

**Volumetric Liquid Density and Viscosity Information**

\* Density at Flow: \_\_\_\_\_ Units:  lb/ft<sup>3</sup>  Kg/m<sup>3</sup>  Other:

OR

Specific Gravity at Flow: \_\_\_\_\_

\* Viscosity at Flow: \_\_\_\_\_ Units:  Centipoise  Other:



**TABLE 8. Custom Gas Worksheet**

\* = Required Item

★ = Default

**Mass Gas Compressibility and Viscosity Information**

1. Fill in the following operating pressures and operating temperatures

Operating Pressures

- 1) \_\_\_\_\_ min
- 2) \_\_\_\_\_ [ $^{1/3}$  (max - min))] + min
- 3) \_\_\_\_\_ [ $^{2/3}$  (max - min))] + min
- 4) \_\_\_\_\_ max

Operating Temperatures

- 5) \_\_\_\_\_ min
- 6) \_\_\_\_\_ [ $^{1/2}$  (max - min))] + min
- 7) \_\_\_\_\_ max
- 8) \_\_\_\_\_ [ $^{1/3}$  (max - min))] + min
- 9) \_\_\_\_\_ [ $^{2/3}$  (max - min))] + min

**2. Transfer the values from the above section to the numbered lines below**

- 3. Check one Density/Compressibility box, then enter the 12 values for each pressure/temperature range.
- 4. Check one Viscosity box, then enter values for each temperature. (At least one viscosity value is required).
- 5. Enter values for molecular weight, isentropic exponent, and standard density (or standard compressibility).

Density

- Density in lbs/CuFt
- Density in kg/CuM
- Compressibility

Pressure                      Temperature

- |          |          |
|----------|----------|
| 1) _____ | 5) _____ |
| 2) _____ | 5) _____ |
| 3) _____ | 5) _____ |
| 4) _____ | 5) _____ |
| 1) _____ | 6) _____ |
| 2) _____ | 6) _____ |
| 3) _____ | 6) _____ |
| 4) _____ | 6) _____ |
| 1) _____ | 7) _____ |
| 2) _____ | 7) _____ |
| 3) _____ | 7) _____ |
| 4) _____ | 7) _____ |

Viscosity

- Viscosity in centipoise
  - Viscosity in lbs/ft sec
  - Viscosity in pascal sec
- Temperature

- 5) \_\_\_\_\_
- 8) \_\_\_\_\_
- 9) \_\_\_\_\_
- 7) \_\_\_\_\_

Molecular Weight: \_\_\_\_\_

Isentropic Exponent: \_\_\_\_\_ 1.4 ★

Standard density/compressibility: \_\_\_\_\_

**Volumetric Gas Compressibility and Viscosity Information**

\* Density at Flow: \_\_\_\_\_ Units:  lb/ft<sup>3</sup>     Kg/m<sup>3</sup>     Other:

OR

M.W. / Specific Gravity at Flow: \_\_\_\_\_

Compressibility at Flow: \_\_\_\_\_

Compressibility at Base: \_\_\_\_\_

\* Viscosity at Flow: \_\_\_\_\_ Units:  Centipoise     Other:    Isentropic Exponent (K): \_\_\_\_\_ 1.4 ★

# Rosemount 285 Annubar Primary Element

**TABLE 9. Natural Gas Worksheet**

**NOTE**

The minimum requirement for the Volumetric options is highlighted gray on page 18.

**Compressibility Factor Information**

Choose desired characterization method and only enter values for that method.

<input type="checkbox"/> Detail Characterization Method (AGA8 1992)		Mole	Valid Range
CH <sub>4</sub>	Methane mole percent _____	%	0 – 100 percent
N <sub>2</sub>	Nitrogen mole percent _____	%	0 – 100 percent
CO <sub>2</sub>	Carbon Dioxide mole percent _____	%	0 – 100 percent
C <sub>2</sub> H <sub>6</sub>	Ethane mole percent _____	%	0 – 100 percent
C <sub>3</sub> H <sub>8</sub>	Propane mole percent _____	%	0 – 12 percent
H <sub>2</sub> O	Water mole percent _____	%	0 – Dew point
H <sub>2</sub> S	Hydrogen Sulfide mole percent _____	%	0 – 100 percent
H <sub>2</sub>	Hydrogen mole percent _____	%	0 – 100 percent
CO	Carbon monoxide mole percent _____	%	0 – 3.0 percent
O <sub>2</sub>	Oxygen mole percent _____	%	0 – 21 percent
C <sub>4</sub> H <sub>10</sub>	i-Butane mole percent _____	%	0 – 6 percent <sup>(1)</sup>
C <sub>4</sub> H <sub>10</sub>	n-Butane mole percent _____	%	0 – 6 percent <sup>(1)</sup>
C <sub>5</sub> H <sub>12</sub>	i-Pentane mole percent _____	%	0 – 4 percent <sup>(2)</sup>
C <sub>5</sub> H <sub>12</sub>	n-Pentane mole percent _____	%	0 – 4 percent
C <sub>6</sub> H <sub>14</sub>	n-Hexane mole percent _____	%	0 – Dew Point
C <sub>7</sub> H <sub>18</sub>	n-Heptane mole percent _____	%	0 – Dew Point
C <sub>8</sub> H <sub>18</sub>	n-Octane mole percent _____	%	0 – Dew Point
C <sub>9</sub> H <sub>20</sub>	n-Nonane mole percent _____	%	0 – Dew Point
C <sub>10</sub> H <sub>22</sub>	n-Decane mole percent _____	%	0 – Dew Point
He	Helium mole percent _____	%	0 – 3.0percent
Ar	Argon mole percent _____	%	0 – 1.0 percent

<input type="checkbox"/> Gross Characterization Method, Option Code 1 (AGA8 Gr-Hv-CO <sub>2</sub> )		Mole	Valid Range
Specific Gravity at 14.73 psia and 60 °F _____			0.554 – 0.87
Volumetric gross heating value at base conditions _____		BTU/SCF	477 – 1150 BTU/SCF
Carbon Dioxide mole percent _____		%	0 – 30 percent
Hydrogen mole percent _____		%	0 – 10 percent
Carbon Monoxide mole percent _____		%	0 – 3.0 percent

<input type="checkbox"/> Gross Characterization Method, Option Code 2 (AGA8 Gr-CO <sub>2</sub> -N <sub>2</sub> )		Mole	Valid Range
Specific Gravity at 14.73 psia and 60 °F _____		%	0.554 – 0.87
Carbon Dioxide mole percent _____		%	0 – 30 percent
Nitrogen mole percent _____		%	0 – 50 percent
Hydrogen mole percent _____		%	0 – 10 percent
Carbon Monoxide mole percent _____		%	0 – 3.0 percent

(1) The summaries of i-Butane and n-Butane cannot exceed 6 percent.

(2) The summaries of i-Pentane and n-Pentane cannot exceed 4 percent.

## Notes

## Product Data Sheet

00813-0100-4028, Rev CA  
March 2008

# Rosemount 285 Annubar Primary Element

---

*Standard Terms and Conditions of Sale can be found at [www.rosemount.com/terms\\_of\\_sale](http://www.rosemount.com/terms_of_sale)*

*The Emerson logo is a trade mark and service mark of Emerson Electric Co.*

*Rosemount, the Rosemount logotype, ProBar, Mass ProBar and Annubar are registered trademarks of Rosemount Inc.*

*MultiVariable (MV), Coplanar, SuperModules, and Tri-Loop are trademarks of Rosemount Inc.*

*Inconel is a trademark of International Nickel Co.*

*Hastelloy is a registered trademark of Haynes International.*

*HART is a registered trademark of the HART Communication Foundation.*

*FOUNDATION is a trademark of the Fieldbus Foundation.*

*All other marks are the property of their respective owners.*

### Emerson Process Management

#### Rosemount Inc.

8200 Market Boulevard  
Chanhassen, MN 55317 USA  
T (U.S.) 1-800-999-9307  
T (International) (952) 906-8888  
F (952) 949-7001

[www.rosemount.com](http://www.rosemount.com)

#### Emerson Process Management

Heath Place  
Bognor Regis  
West Sussex PO22 9SH  
England  
T 44 (0) 1243 863121  
F 44 (0) 1243 867554

#### Emerson Process Management Asia Pacific Private Limited

1 Pandan Crescent  
Singapore 128461  
T (65) 6777 8211  
F (65) 6777 0947  
[Enquiries@AP.EmersonProcess.com](mailto:Enquiries@AP.EmersonProcess.com)

