

IN-SITU ZIRCONIA OXYGEN ANALYZER

<HART communication>

DATA SHEET

ZFK8, ZKMA/ZKMB, ZTA

This oxygen analyzer can continuously measure oxygen concentration in combustion exhaust gas of industrial boilers or furnaces, and is suited to combustion management and control.

The analyzer system is comprised of the detector and converter coupled together as a complete system. The detector includes the flow guide tube and the sensor. The flow guide tube inserted into the stack draws the process gas into the sensor. The converter has the sensor diagnosis function which ensure the long-term use and the stability of the sensor.

FEATURES

- No gas sampling devices required**
Insertion type sensor delivers quick response.
- Easy maintenance**
Modular design allows easy replacement of sensor, flow guide tube, and filter.
- Reliability and long-term stability**
To check the degree of sensor depletion due to gas components in the target gas, the converter has the sensor diagnostic function so that you know when to replace the sensor.
- Improved safety**
The converter cuts off the power supply for the detector when detecting a burnout of thermocouple for heater control. The converter also cuts off the power supply at emergency, in response to an external contact input. These functions along with the key lock function are equipped as standard to ensure improved safety.
- Easy operation**
A user can operate the converter or make various settings on an interactive basis. Display language is available in English, Chinese, or Japanese.
- HART communication (option)**
The HART communication enables remote control.
*HART® is a registered trademark of the FieldComm Group.

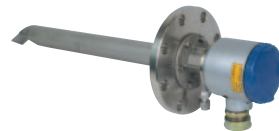

Detector with flow guide tube (ZFK8)

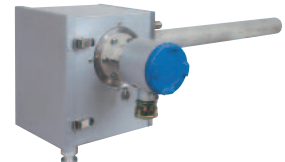

Detector with ejector (ZFK8, ZTA)



IP66 Converter (ZKMA)



IP67 Converter (ZKMB)

SPECIFICATIONS

General Specifications

Measuring object:	Oxygen in noncombustible gas
Measuring method:	Insertion type zirconia sensor
Measuring range:	0 to 2 ... 50 vol% O ₂ (in 1 vol% O ₂ steps)
Repeatability:	Within ±0.5%FS
Linearity:	Within ±2%FS
Response time:	Within 4 to 7 sec, for 90% (from calibration gas inlet)
Warmup time:	≥ 10 min
Analog output:	4 to 20mA DC (allowable load resistance ≤ 500Ω) or 0 to 1V DC (output resistance ≥ 100Ω), linear, isolated
Power supply:	Rated voltage; 100 to 120V AC (operating voltage 90 to 132V AC) 200 to 240V AC (operating voltage 190 to 264V AC) Rated frequency; 50/60Hz
Power consumption:	Startup: 255VA During operation: 70VA [When the power supply voltage is 100 or 220 V AC]

Detector (ZFK)

Measured gas temperature:

Flow guide tube system; -10 to +600°C
(for general-use, corrosive gas)
Ejector system; -10 to +1500°C (for
high-temperature gas)
-10 to +800°C (for general-use)

Measured gas pressure:

-3 to +3kPa

Flow guide tube:

- General-use, for corrosive gas, with
blowdown nozzle:
Flange: JIS 5K 65A FF
Insertion length: 0.3, 0.5, 0.75, 1 m
- For high particulate:
*The flow guide tube for high par-
ticulate gas comes with blowdown
nozzle. You can select the one with
or without the flow guide tube cover.
Flange: JIS 5K 80A FF
Insertion length: 0.3, 0.5, 0.75, 1 m

Ambient temperature:

Detector: -10 to +60°C
Detector flange surface: ≤ 125°C during
the power is supplied
Ejector: -5 to +100°C
*When sample gas temperature is
lower than 150°C and the outside
temperature is lower than 0°C, cover
the flow guide tube flange and the
detector (the part that contact outside
air) with thermal insulating material to
prevent dew condensation.

Storage temperature:

Detector: -20 to +70°C
Ejector: -10 to +100°C

IP rating:

Equivalent to IP66 excluding the filter
The heat-retaining cover (12th code) is
required for the use in a cold area.

Filter:

Alumina(filtering accuracy 50µm) and
quartz paper

Main materials of gas-contacting parts:

Detector; Zirconia, SS316, platinum
Flow guide tube; SS304 or SS316
Ejector (general use); SS316, SS304
Ejector; (for high temperature) SiC,
SS316, SS304

Pipe adapter for calibration gas inlet:

for 6 mm tube or 1/4 inch tube (as
selected in the 6th code)

Pipe adapter for reference gas inlet (option):

for 6 mm tube or 1/4 inch tube (as
selected in the 13th code)

Installation:

Horizontal plane ±45°, ambient air
should be clean.

Dimensions:

(L × max. dia.) 194mm × 125.5mm

Weight:

Detector; 1.6kg
Ejector; 15kg (insertion length 1m)
Flow guide tube (general-use, 1m); 5kg

Finish color:

Silver and SS metallic color

Calibration gas flow:

1.5 to 2 L/min

Blowdown air inlet pressure:

200 to 300kPa

Ejector:

Probe for guiding measured gas to
detector
Flange; JIS10K 65A RF
Insertion length; 0.5, 0.75, 1, 1.5m (ac-
cording to customer's specification)

Ejector air inlet flow rate:

5 to 10 L/min

Ejector exhaust gas processing:

Returned to flue or furnace

Ejector heater temperature drop alarm output:

SPST-NO contact, 200 V AC, 2A
Mechanical thermostat
The contact is closed when the heater
temperature is 100°C or lower.

Converter (ZKM)

Concentration value indication:

Digital indication in 4 digits

Contact output:

- 6 points, SPST-NO,
250 V AC, 3A or 30 V DC, 3A
Functions; • Under maintenance
• Error*¹
• Alarm*²
• Zero calibration gas
• Span calibration gas
• Blowdown*³

Notes

1. The contact is closed upon: open circuit of thermo-
couple line, open circuit of O₂ sensor line, tempera-
ture overrange, calibration error, zero/span error,
output error.
2. The contact is closed upon the alarm you selected
among: H, L, HL, HH, LL.
3. The contact is closed during blowdown. This func-
tion is available only on the version with blowdown
nozzle.

Contact input:

- 3 points
ON; 0V (10mA or less), OFF; 5V
Functions; • External hold
• Calculation reset
• Heater OFF
• Blow down (option)
• Inhibition of calibration
• Calibration start
• Range change

Calibration method:

- (a) Manual calibration with key operation
- (b) Auto. calibration (option)
Calibration cycle; 00 day 00 hour to
99 days 23 hours
- (c) Batch calibration

Calibration gas:

- Setting range
Zero gas; 0.010 to 25.00% O₂
Span gas; 0.010 to 50.00% O₂
- Recommended calibration gas concen-
tration
Zero gas; 0.25 to 2.0% O₂
Span gas; 20.6 to 21.0% O₂
(oxygen concentration in the air)

Blowdown: (option) A function for blowing out dust that has accumulated in the flow guide tube. Blowdown can be performed for a pre-determined time and at predetermined intervals.
 Blowdown cycle; 00 hour 00 minute to 99 hours 59 minutes
 Blowdown time; 0 minute 00 second to 0 minutes 999 seconds

Output signal hold: The converter holds the output signal during: calibration, blowdown, sensor recovery, sensor diagnosis, PID auto-tuning, and during the maintenance mode is set to "yes". You can cancel the output hold function during warm-up.

Selector valve and flowmeter (option): The selector valve allows you to switch between the zero gas and the span gas when you carry out a calibration. The flowmeter is used for regulating the flow rate of the calibration gas.

Communication (option):
 HART or
 RS485 (MODBUS)

Combustion efficiency display (option):
 This function calculates and displays combustion efficiency from oxygen concentration and measured gas temperature.
 Thermocouple (R) or thermocouple (K) is required for temperature measurement.
 Range: 0 to 1000°C, Accuracy: ±5°C.
 On the version with combustion efficiency display, an alarm function of "rich mode" indication is also available.

Ambient temperature:
 -20 to +55°C

Ambient humidity:
 95% RH or less, non condensing

Storage temperature:
 -30 to +70°C

Storage humidity: 95% RH or less, non condensing

IP rating: Equivalent to IP66 or IP67

Case material: Aluminum case

Dimensions (H x W x D):
 170 x 159 x 70mm (IP66)
 220 x 230 x 95mm (IP67)

Weight:
 IP66: Approx. 2kg (excluding cable and detector)
 IP67: Approx. 4.5kg (excluding cable and detector)
 Cable: Approx. 4kg/m (with rainproof flexible conduit)

Finish color:
 Case: Silver
 Cover: Munsell 6PB 3.5/10.5 (blue)

Installation: panel mounting or pipe mounting

EU Directive Compliance

LVD (2014/35/EU)
 EN 61010-1
 EN 62311
EMC (2014/30/EU)
 EN 61326-1 (Table 2)
 EN 55011 (Group 1 Class A)
 EN 61000-3-2 (Class A)
 EN 61000-3-3
 EN 61326-2-3
RoHS (2011/65/EU)
 EN 50581

*Ejector ZTA is non-compliant with CE marking.

CODE SYMBOLS

Detector

ZFK8

5	6	7	8
R			5

 -

9	10	11	12	13

 -

14	15	16
1		

Digit	Description	Note	Code
6	Pipe adapter for calibration gas inlet For ø 6mm tube (SS) For ø 1/4 inch tube (SS) With ball valve		1 2 3
7	Power supply 100 to 120 V AC 50/60 Hz 200 to 240 V AC 50/60 Hz		1 3
8	Revision No.		5
9	Flow guide tube		
10	<Flange> <Application> <Length>		
11	No tube		0Y0
	SS304 general use 300 mm		5A3
	SS304 general use 500 mm		5A5
	SS304 general use 750 mm		5A7
	SS304 general use 1000 mm		5A1
	SS316 for corrosive gas 300 mm		5B3
	SS316 for corrosive gas 500 mm		5B5
	SS316 for corrosive gas 750 mm		5B7
	SS316 for corrosive gas 1000 mm		5B1
	SS316 with blowdown nozzle 300 mm		5C3
	SS316 with blowdown nozzle 500 mm		5C5
	SS316 with blowdown nozzle 750 mm		5C7
	SS316 with blowdown nozzle 1000 mm		5C1
	SS316 for high particulate 300 mm		6D3
	SS316 for high particulate 500 mm		6D5
	SS316 for high particulate 750 mm		6D7
	SS316 for high particulate 1000 mm		6D1
	SS316 for high particulate with cover 300 mm		6E3
	SS316 for high particulate with cover 500 mm		6E5
	SS316 for high particulate with cover 750 mm		6E7
	SS316 for high particulate with cover 1000 mm		6E1
	Others		ZZZ
12	Heat-retaining cover Without With		Y A
13	Pipe adapter for reference gas inlet None For ø 6 mm tube (SS) For ø 1/4 inch tube (SS)		Y A B
14	Filter spec Standard		1
15	Instruction manual Japanese English Chinese		J E C
16	Specification nameplate 100 to 120 V AC 50/60 Hz 200 to 240 V AC 50/60 Hz		1 2

Dedicated cable

ZRZ

4	5	6	7	8	9
K	R			1	

 -

Digit	Description	Note	Code
4	Connectable device ZKM		K
5	Type R thermocouple		R
6	Length		
7	<Rainproof flexible conduit> <Cable>		
	None 6 m		YA
	None 10 m		YB
	None 15 m		YC
	None 20 m		YD
	None 30 m		YE
	None 40 m		YF
	None 50 m		YG
	None 60 m		YH
	None 70 m		YJ
	None 80 m		YK
	None 90 m		YL
	None 100 m		YM
	6 m 6 m	Note 5	AA
	10 m 10 m	Note 5	BB
	15 m 15 m	Note 5	CC
	20 m 25 m	Note 5	DD
8	Revision No.		1
9	Cable end treatment None One side (detector side) Both sides		0 1 2

Note 5) For connection between detector and converter, use a rainproof flexible conduit.

Converter

ZKM

4	5	6	7	8
				2

 -

9	10	11	12	13
				1

 -

14	15	16
Y	R	

Digit	Description	Note	Code
4	Enclosure IP66 IP67		A B
5	Analog output signal 4 to 20 mA DC 0 to 1 V DC		B E
6	Communication None RS-485 HART		Y 2 3
7	Mounting bracket None Panel mounting Pipe mounting		Y 1 2
8	Revision No.		2
9	Optional functions None Combustion efficiency display Blowdown Auto calibration Combustion efficiency display + Blowdown Combustion efficiency display + Auto calibration Blowdown + Auto calibration Combustion efficiency display + Blowdown + Auto calibration	Note 1 Note 2 Note 2, 3 Note 1 Note 1, 3 Note 2, 3 Note 1	Y 1 2 3 4 5 6 7
10	Display language Japanese English Chinese		J E C
11	Selector valve/flowmeter None With valve (For ø6 mm tube) With valve + flowmeter (For ø6 mm tube) With valve (For ø1/4 inch tube) With valve + flowmeter (For ø1/4 inch tube)	Note 3	Y 1 2 3 4
12	—		1
13	Cable gland Without With		Y A
14	—		Y
15	—		R
16	Thermocouple for combustion efficiency display None Type R thermocouple Type K thermocouple	Note 4 Note 4	Y R K

Notes

- On the version with the combustion efficiency display, the rich mode indicator is available.
If you order the version with combustion efficiency display (9th code 1, 4, 5, or 7), select "R" or "K" in the 16th digit.
- If you order the version without combustion efficiency display (9th code Y, 2, 3, or 6), select "Y" in the 16th digit.
- If you order the version with auto calibration (9th code 3, 5, 6, or 7), select "Y" in the 11th digit.
- A thermocouple is to be prepared by customer.

Ejector *Non-compliant with CE marking

ZTA

4	5	6	7	8
				1

 -

1

Digit	Description	Note	Code
4	Measured gas temperature For high temperature (+1500°C max.) General use (+800°C max.)		1 2
5	—		1
6	Insertion length [mm] 500 750 1000 1500		B C D E
7	Power supply voltage 100V/115 V AC 50/60Hz 200V/220 V AC 50/60Hz 230 V AC 50/60Hz		1 3 5
8	Revision No.		1

SCOPE OF DELIVERY

		Description	Q'ty	
Detector (ZFK)	Detector		1	
	Viton O ring		1	
	Mounting screw (M5 x 16)		6	
	Thermal sticker		1	
	Ceramic filter		1	
	Instruction manual		1	
	Flow guide tube (as specified)		1	
	Heat-retaining cover (as specified)		1	
	Reference gas inlet port (as specified)		2	
Converter (ZKM)	Converter		1	
	Fuse (2.5A)		2	
	Ferrite core		1	
	Instruction manual		1	
	Metal fittings	<For panel mounting> M8 sems screw (stainless steel)		4
		<For pipe mounting> U bolt (stainless steel)		2
		M8 nut and washer (stainless steel)		4
Support (stainless steel)		2		
Ejector (ZTA)	Ejector main unit		1	
	Insertion tube		1	
	Packing		1	
	M16 nut and washer (stainless steel)		4	
Dedicated cable (ZRZ)	Cable (of the specified length)		1	

Items to be prepared separately:

- (1) Standard gas for calibration
 - Type ZBM□NSH4-01 (up to 5% O₂ range)
 - Type ZBM□NSJ4-01 (over 5% O₂ range)
- (2) Pressure regulator for standard gas (type ZBD61003)
- (3) Flowmeter
 - Type; ZBD42203, 0.2 to 2L/min (for calibrating gas)
 - Type; ZBD42403, 1 to 10L/min (for ejector)

IMPORTANT INFORMATION

- Combustible gases such as CO and H₂ in the measured gas cause measurement error.
- Corrosive gases, for example, Si vapor, alkaline metal, P, and Pb, may shorten the life of the sensor.
- If the gas temperature reaches 300°C or above, remote the detector flange from the furnace wall so that the surface temperature of the flange will not go higher than 125°C. Mount the flow guide tube in such a direction that less gas flows into the detector.
- When the dust contained in the process gas is high, install the flow guide tube inclined downward, and in such a direction that less gas flows into the detector.
- If you use the analyzer in a waste incinerator, do not use the automatic blowdown because it causes corrosion of the flow guide tube due to drain water. Carry out blowdown manually after the furnace is stopped and the change in readings is decreased.

Replacement detector element

Power supply	Code symbols
100 to 120V AC	ZFK8YY15-0Y0YY-0YY
200 to 240V AC	ZFK8YY35-0Y0YY-0YY

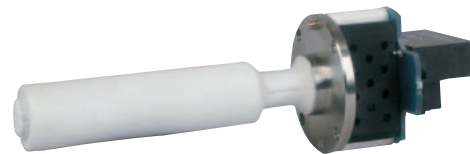

DETECTOR SELECTION GUIDE

The device combination varies according to the conditions of the gas to be measured. Select the appropriate devices to be combined with reference to the following table.

Application		Gas conditions				Detector			Converter	Ejector
		Temp.	Flow rate	Dust	Moisture	Flange material	Flow guide tube	9th–11th code		
Boilers	Gas, oil	≤ 600 °C	5–20 m/s	< 0.2 g/Nm ³	Low	SS 304	Standard	5A□	ZKMA or ZKMB	—
	Coal			< 10 g/Nm ³	Low		With blowdown nozzle	5C□		
Refuse incinerators	≤ 600 °C	5–20 m/s	< 1 g/Nm ³	Low	SS 316	For corrosive gas	5B□			
			< 10 g/Nm ³	Low		With blowdown nozzle	5C□			
			< 25 g/Nm ³	Low		For high particulate	6D□			
			< 25 g/Nm ³	High		For high particulate, with cover	6E□			
Heating furnaces	≤ 800 °C	≤ 1 m/s	< 1 g/Nm ³	Low	—	No flow guide tube	0Y0	ZTA2		
	≤ 1500 °C	≤ 1 m/s	< 1 g/Nm ³	Low	—	No flow guide tube	0Y0	ZTA1		

Notes

- Dust volumes listed above are approximate value.
- If the oxygen concentration of ambient air fluctuates, select a detector with a pipe adapter for reference gas inlet (13th code A or B).
- Consult us for specifications not listed above.

CONFIGURATION

Flow guide tube system (with valve)

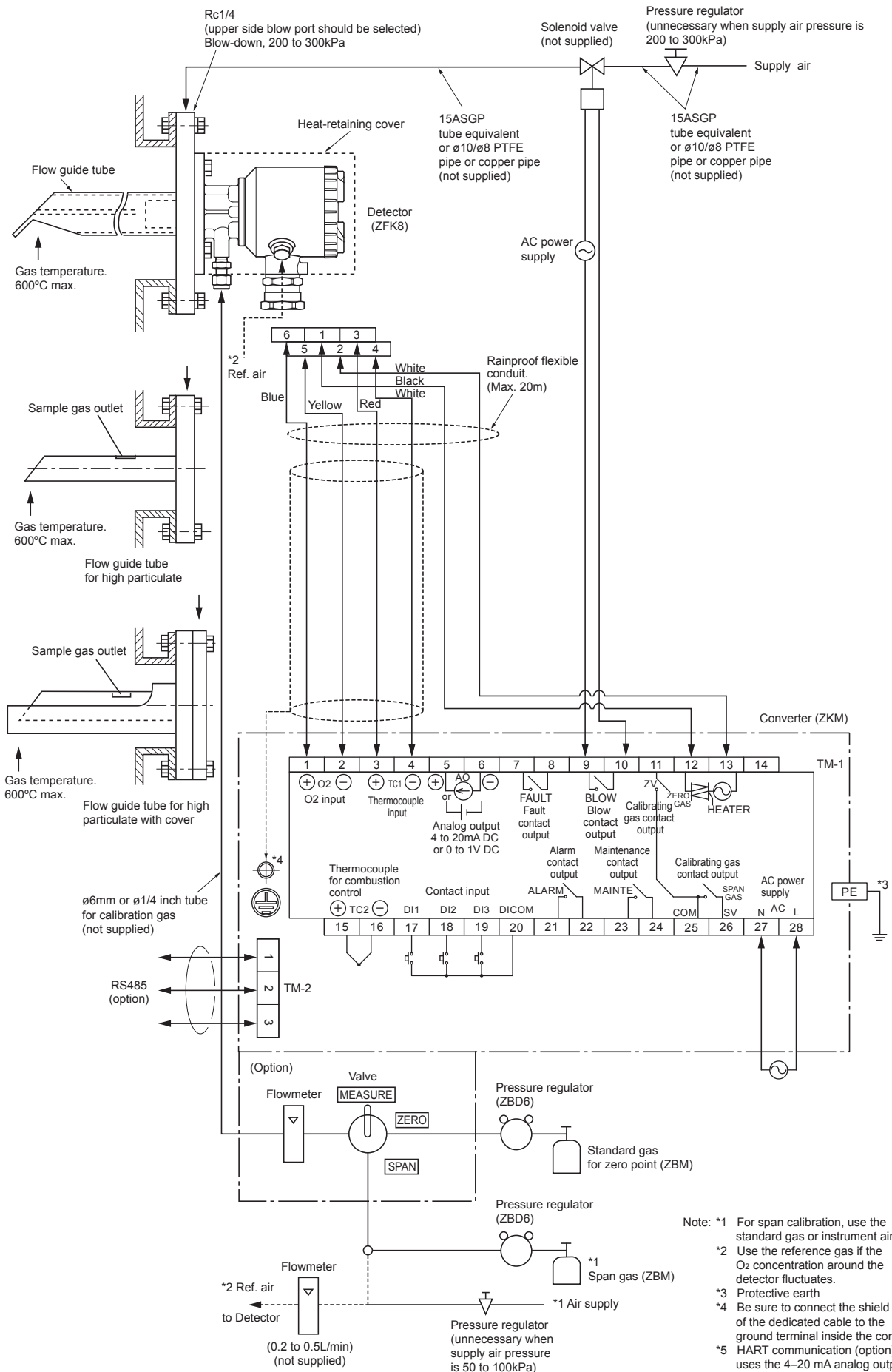

Flow guide tube system

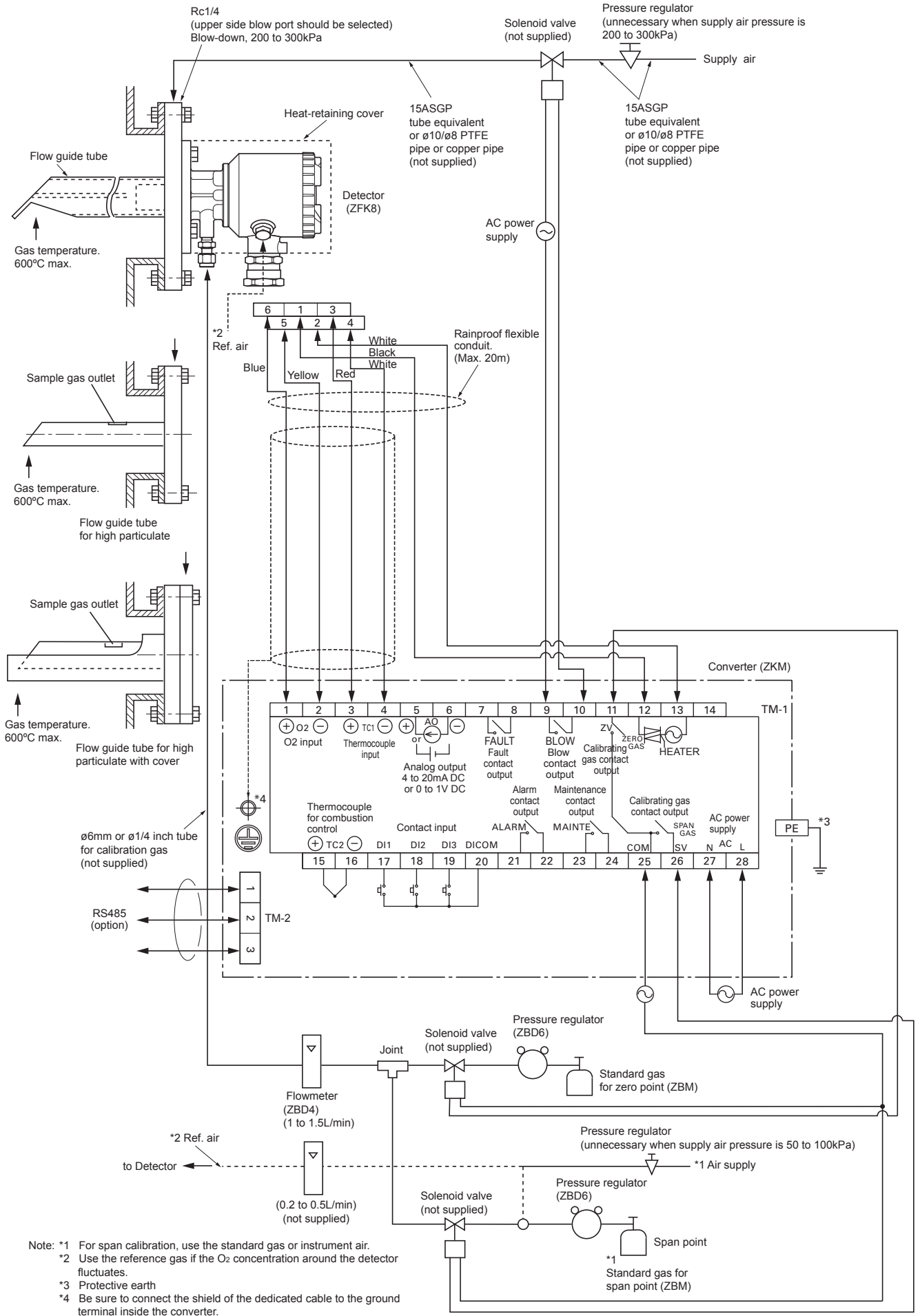

- Note: *1 For span calibration, use the standard gas or instrument air.
 *2 Use the reference gas if the O₂ concentration around the detector fluctuates.
 *3 Protective earth
 *4 Be sure to connect the shield of the dedicated cable to the ground terminal inside the converter.
 *5 HART communication (option) uses the 4–20 mA analog output line.

Ejector system (with valve)

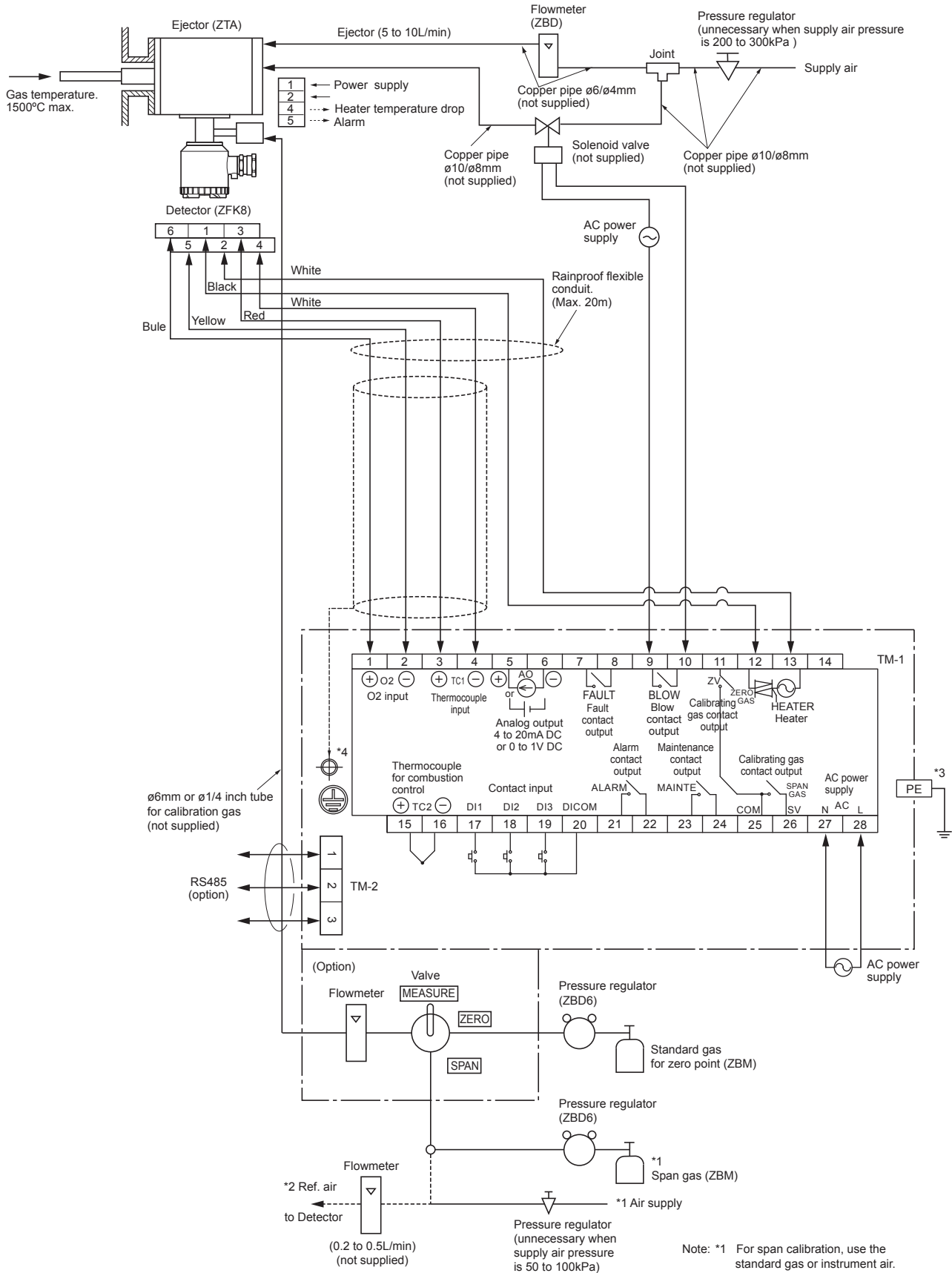

- Note: *1 For span calibration, use the standard gas or instrument air.
 *2 Use the reference gas if the O₂ concentration around the detector fluctuates.
 *3 Protective earth
 *4 Be sure to connect the shield of the dedicated cable to the ground terminal inside the converter.
 *5 HART communication (option) uses the 4–20 mA analog output line.

Ejector system

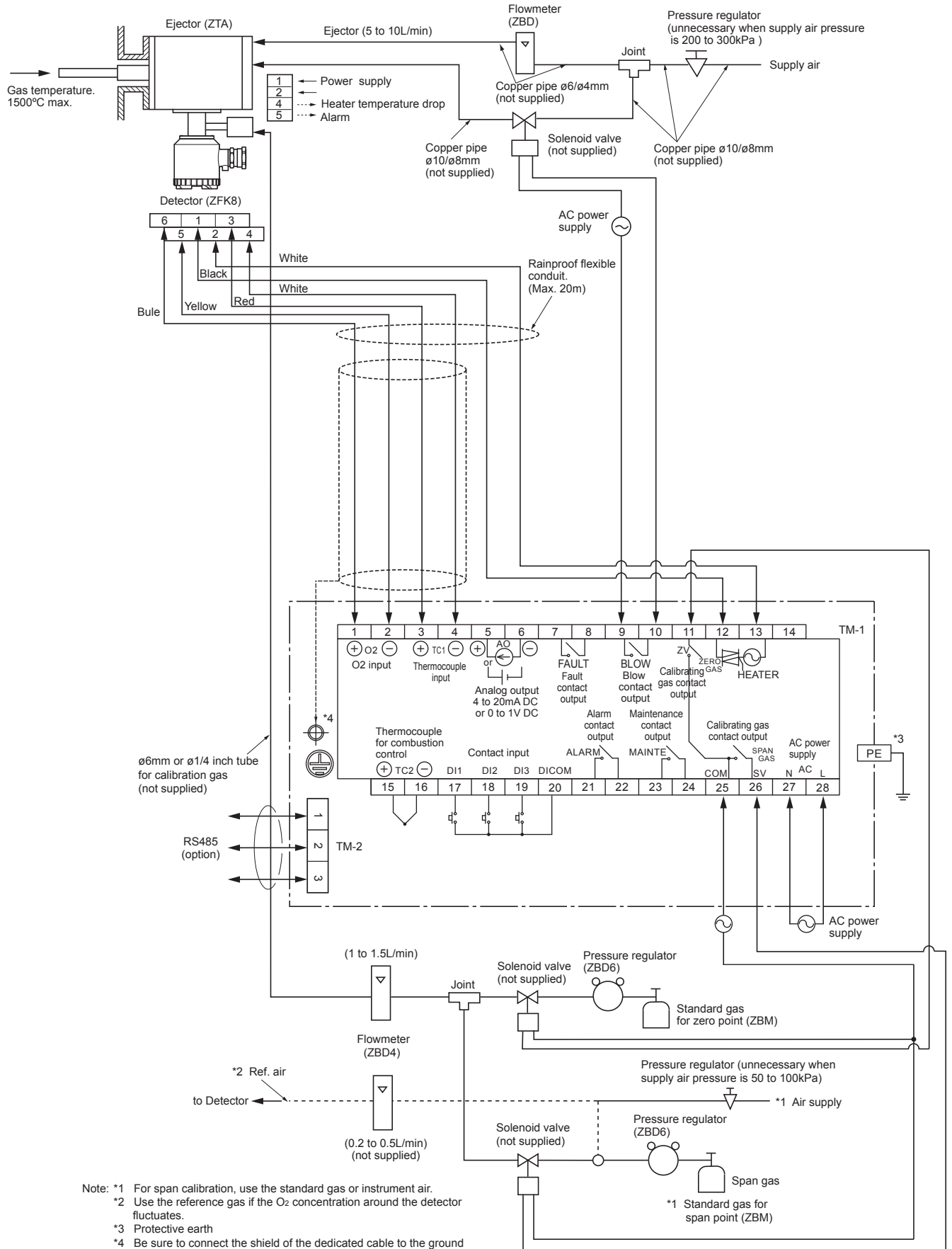

- Note: *1 For span calibration, use the standard gas or instrument air.
 *2 Use the reference gas if the O₂ concentration around the detector fluctuates.
 *3 Protective earth
 *4 Be sure to connect the shield of the dedicated cable to the ground terminal inside the converter.
 *5 HART communication (option) uses the 4–20 mA analog output line.

OUTLINE DIAGRAM (Unit:mm)

Detector (ZFK8)

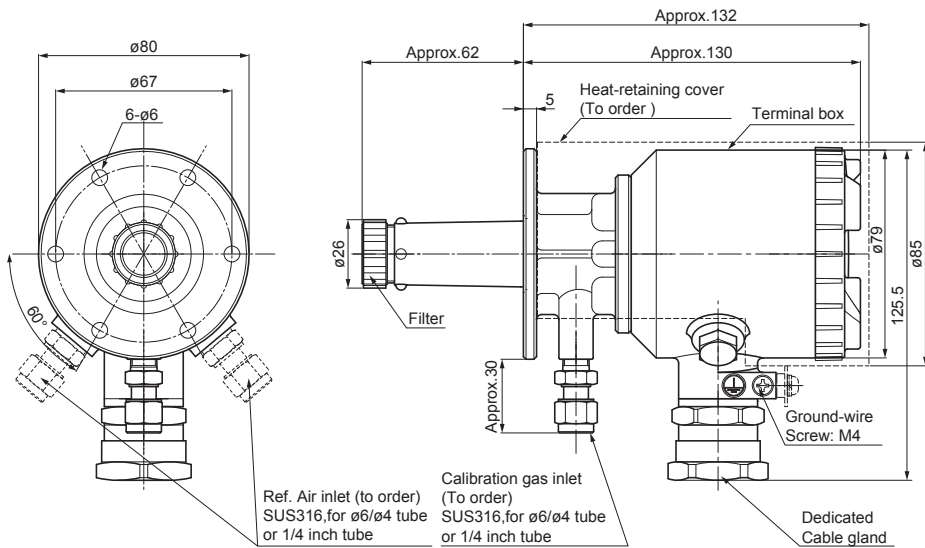

EXTERNAL CONNECTION DIAGRAM

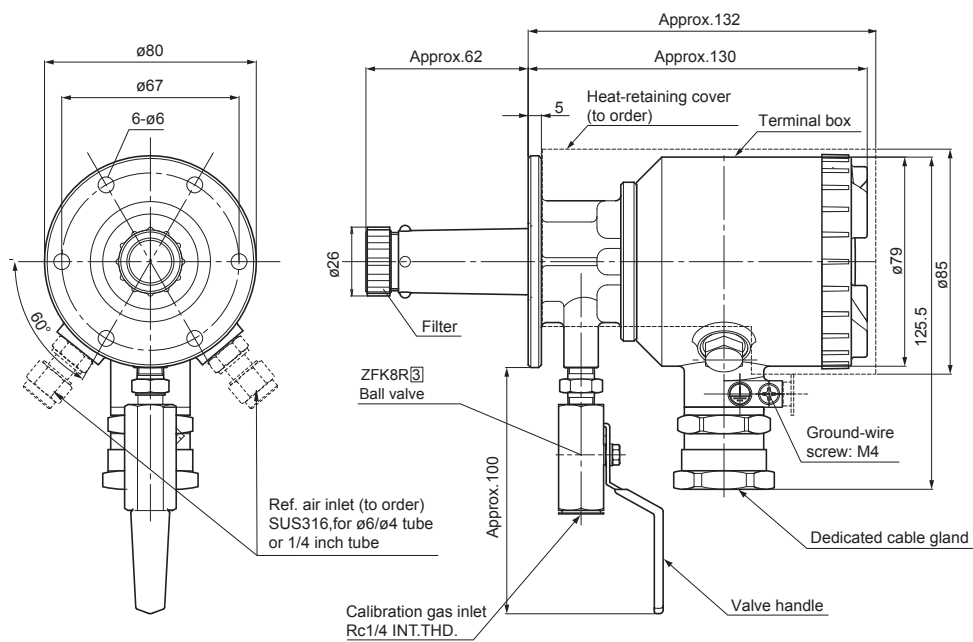
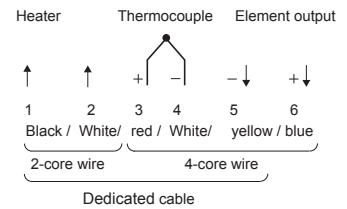

Sensor unit (ZFK8YY)

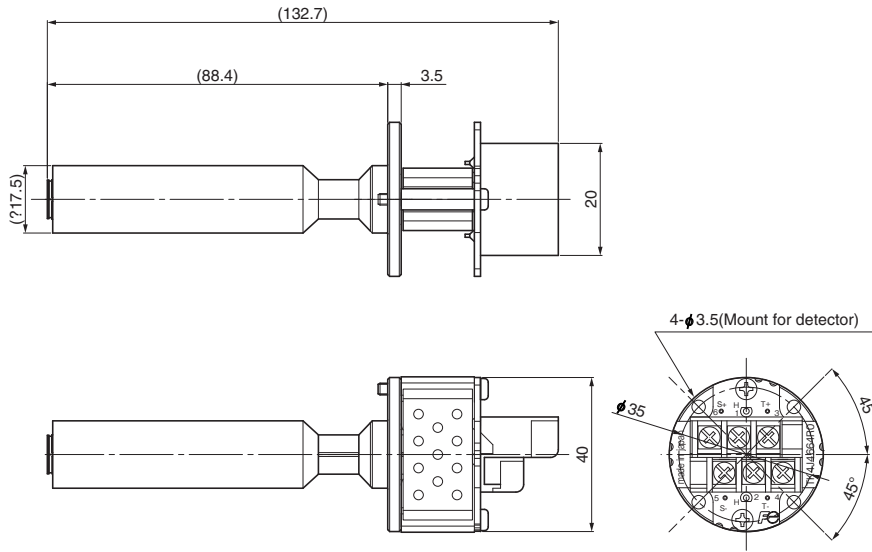

Flow guide tube

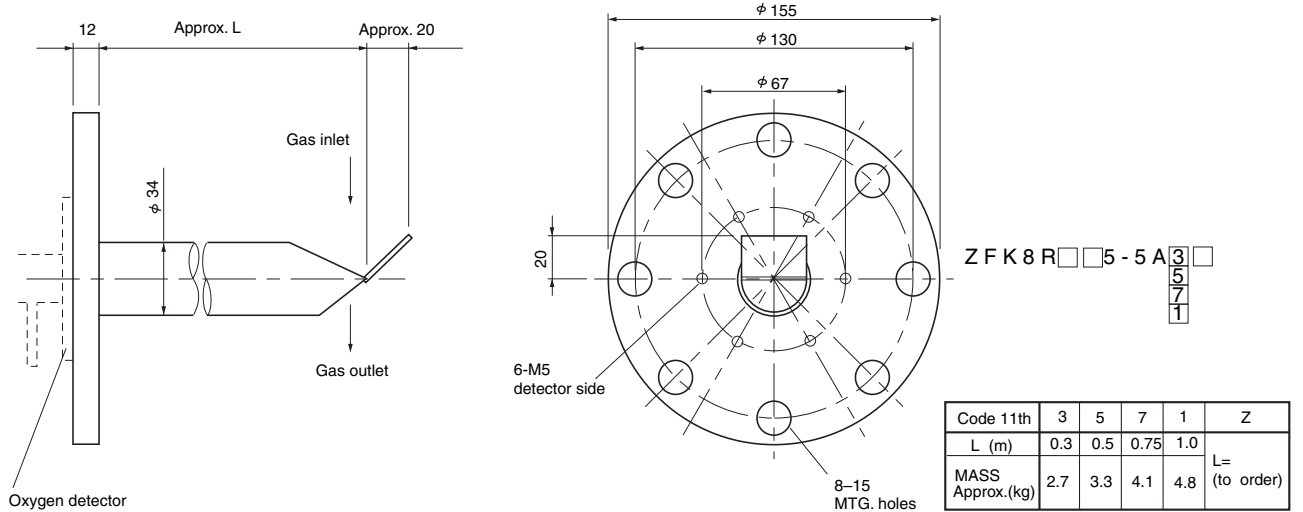

Flow guide tube (with blow-down nozzle)

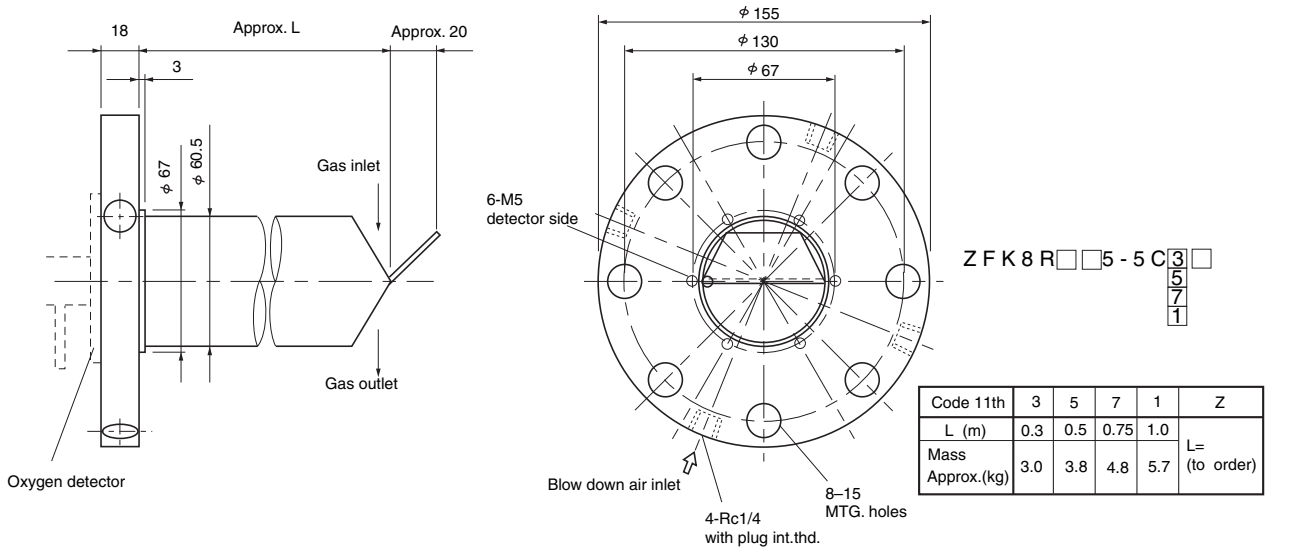

Flow guide tube (for high particulate)

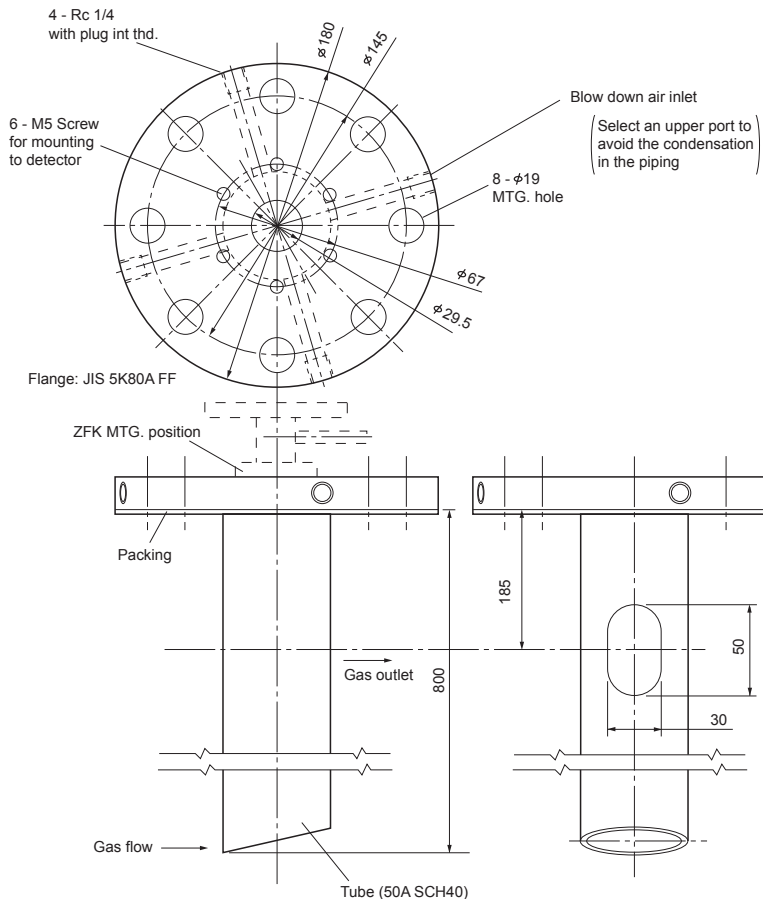

ZFK8R□□5-6D $\begin{matrix} 3 \\ 5 \\ 7 \\ 1 \end{matrix}$ □

Code 11th	3	5	7	1	Z
L (m)	0.3	0.5	0.75	1.0	L= (to order)
Mass Approx.(kg)	4.5	5.6	7.0	8.3	

Flow guide tube (for high particulate with cover)

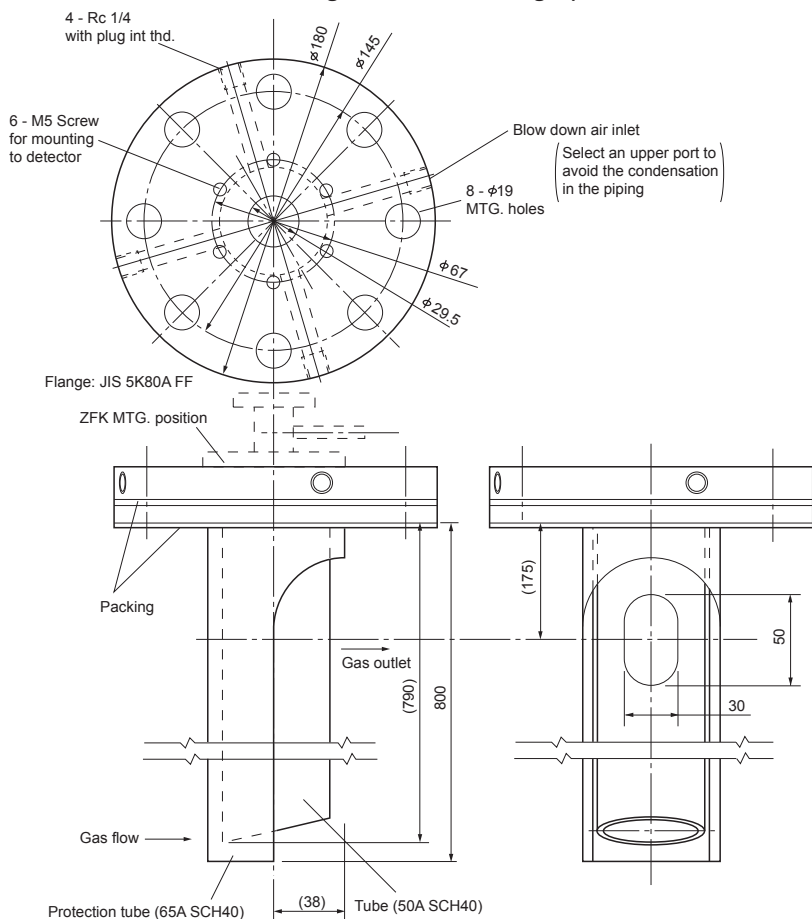

ZFK8R□□5-6E $\begin{matrix} 3 \\ 5 \\ 7 \\ 1 \end{matrix}$ □

Code 11th	3	5	7	1	Z
L (m)	0.3	0.5	0.75	1.0	L= (to order)
Mass Approx.(kg)	7.1	9.0	11.4	13.6	

Flow guide tube (for corrosive gas)

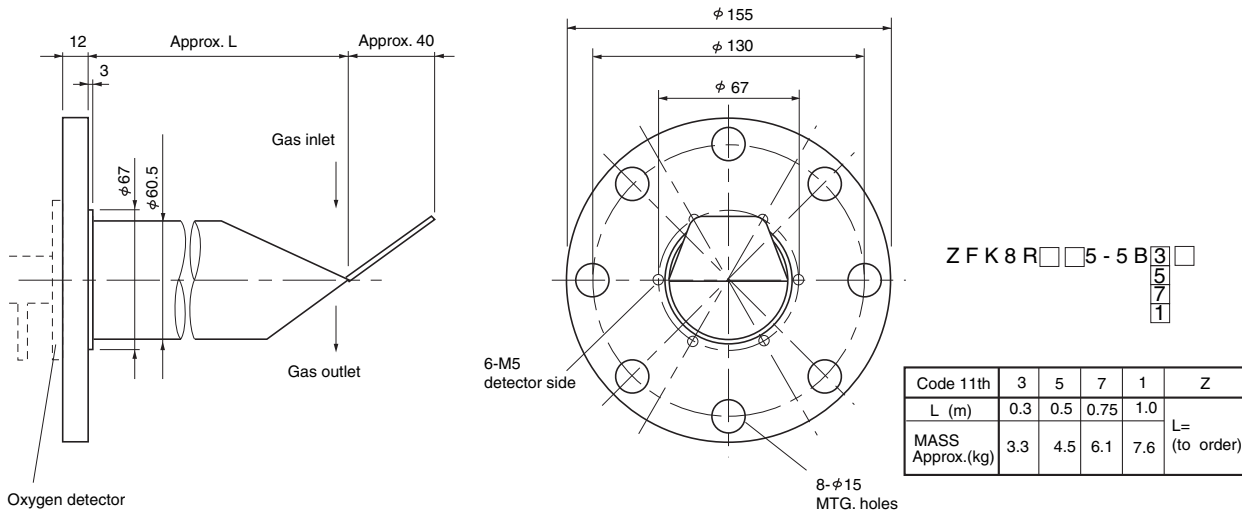

Ejector (ZTA)

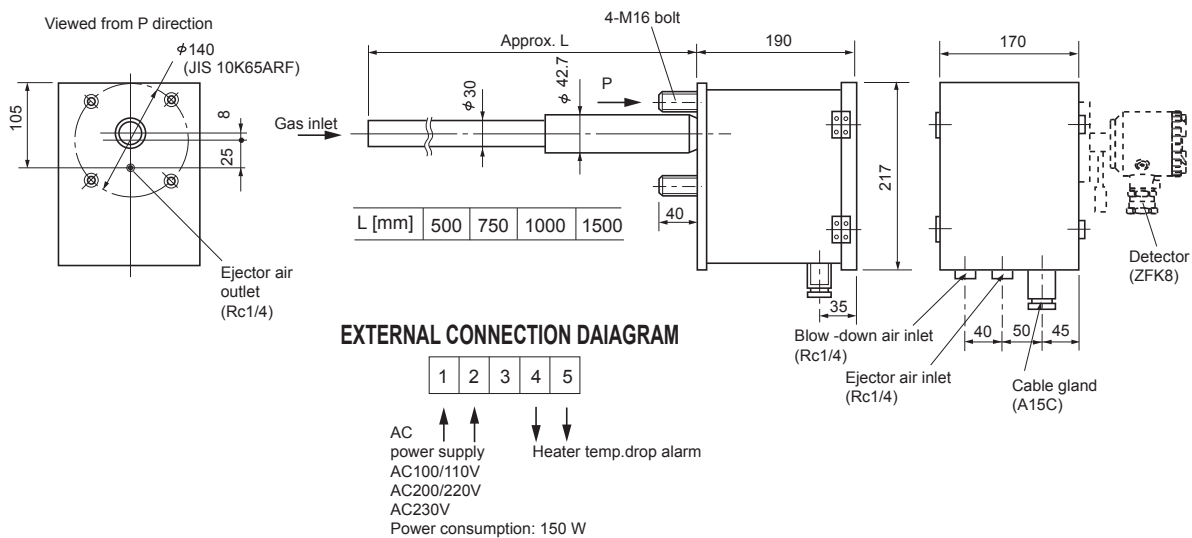

Converter (ZKMA)
<IP66 enclosure>

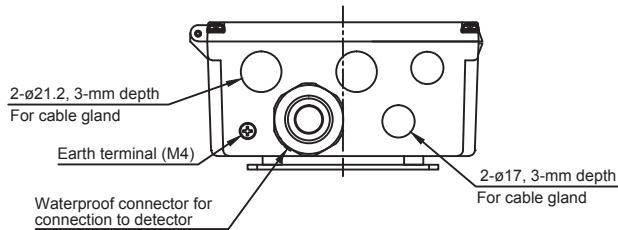
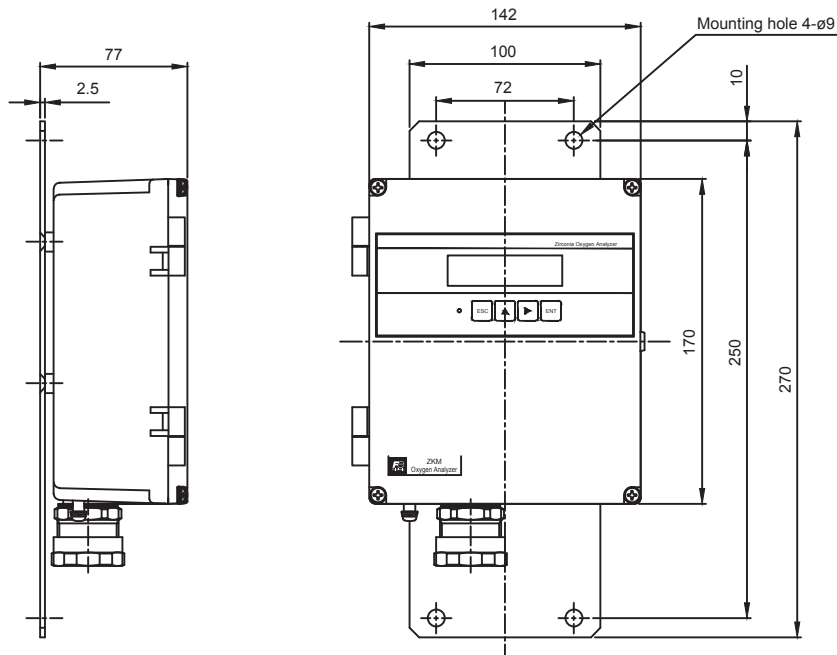

EXTERNAL TERMINAL (TM1) / M3 screw terminals

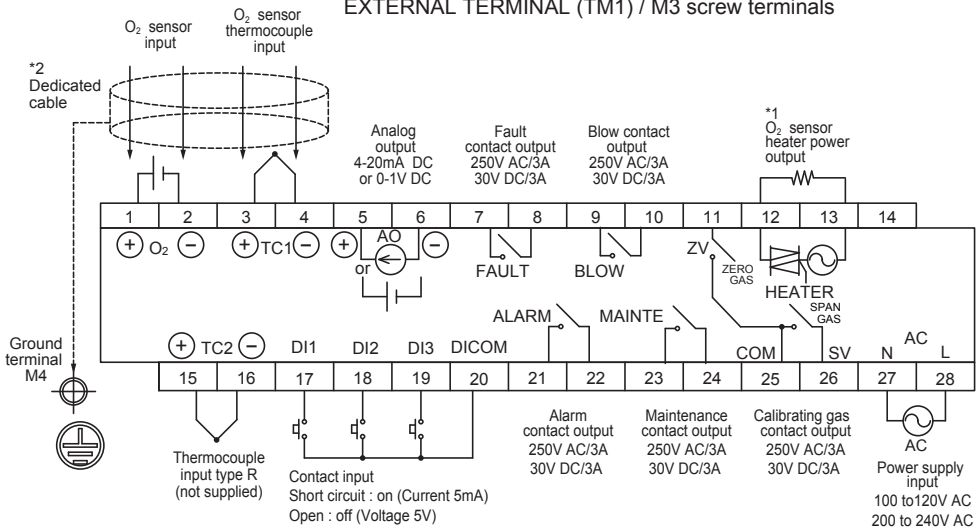

RS-485 communication terminal (TM2, option) / Euro-style terminals

1	2	3
GND	TRX-	TRX+

Notes:

- *1. The heater uses the same power source as the converter.
- *2. Connect the shield of the dedicated cable to the ground terminal inside the converter.
- *3. HART communication (option) uses the 4-20 mA analog output line.

Converter (ZKMA)
 <IP66 enclosure> with selector valve

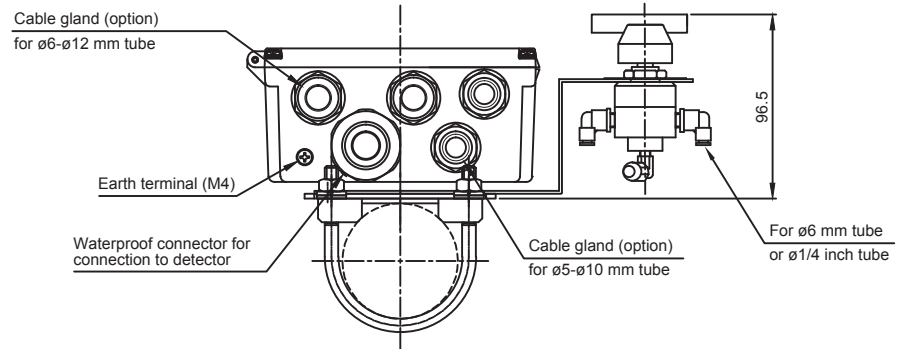
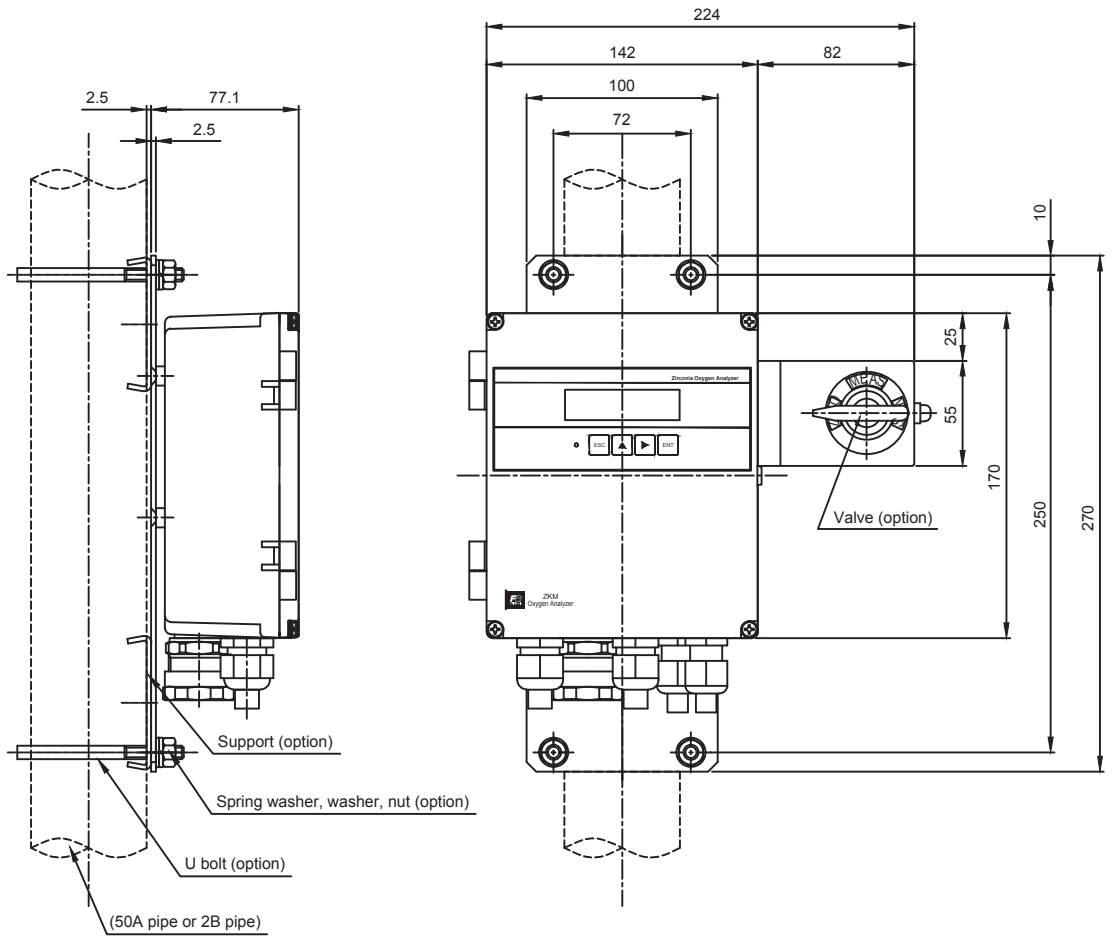

Converter (ZKMA)
 <IP66 enclosure> with selector valve and flowmeter

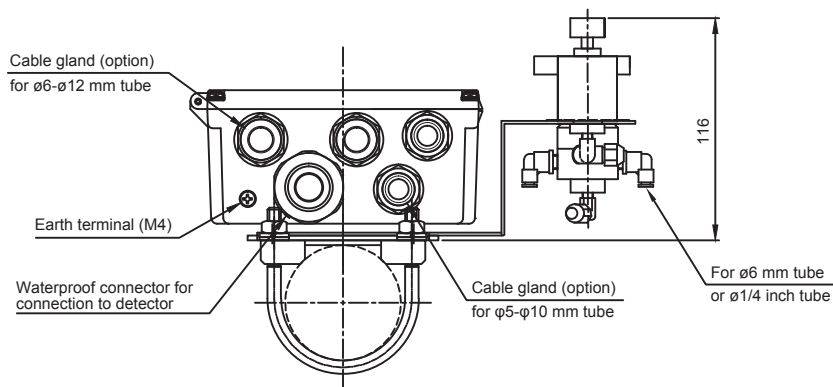
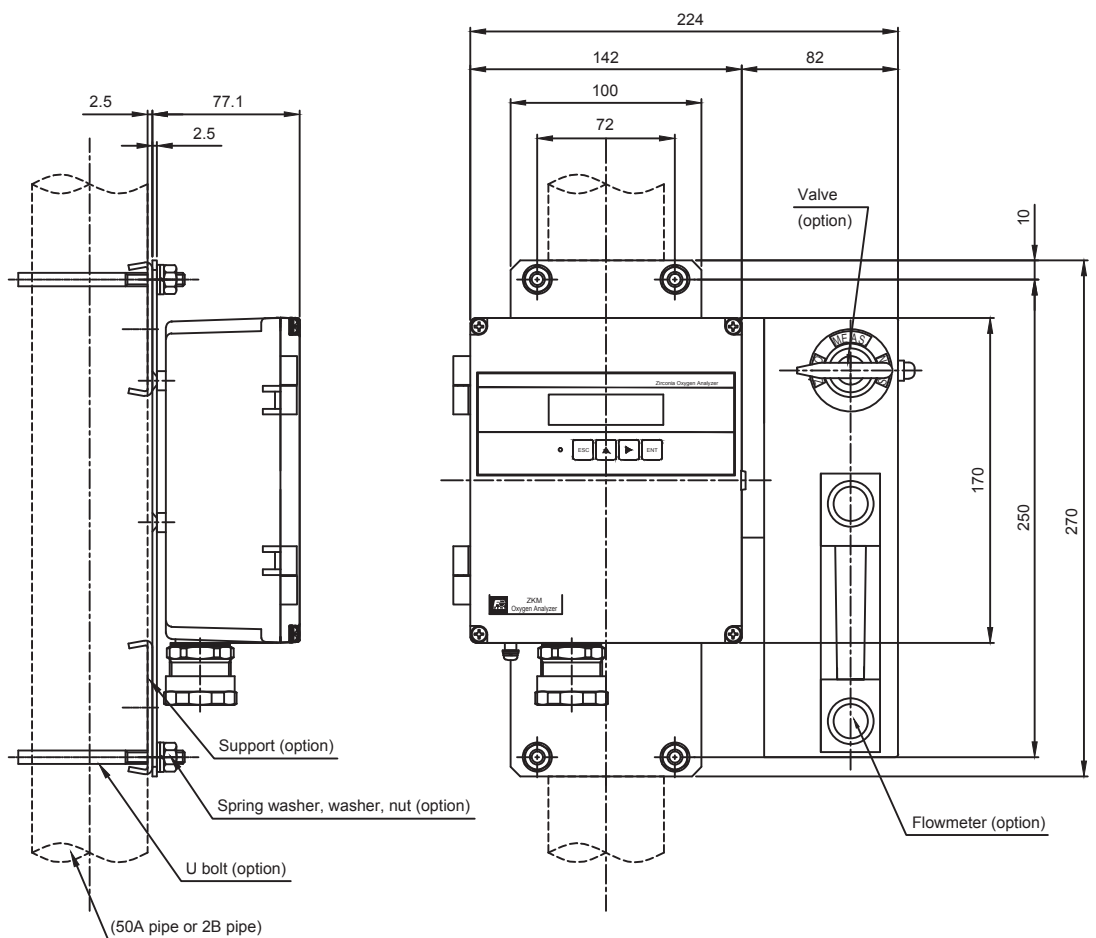

Converter (ZKMB)
<IP67 enclosure>

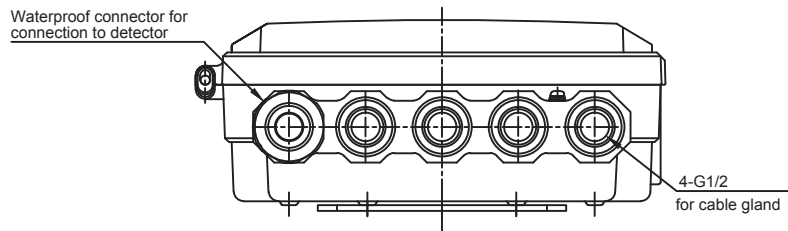
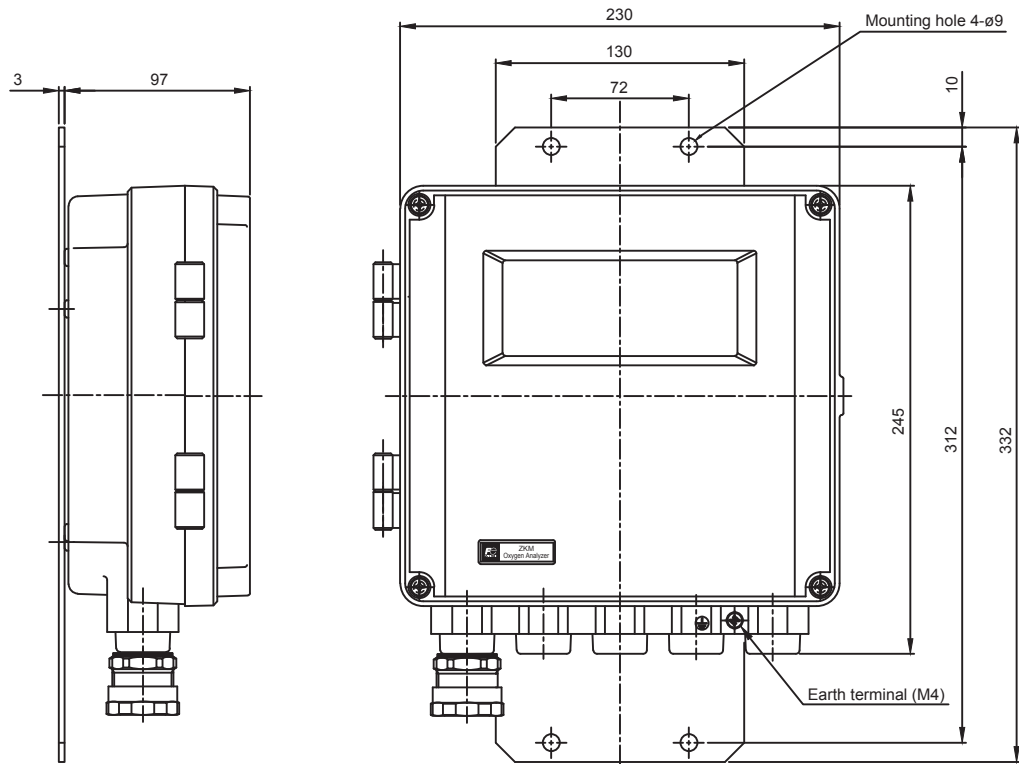

EXTERNAL TERMINAL (TM1) / M3 screw terminals

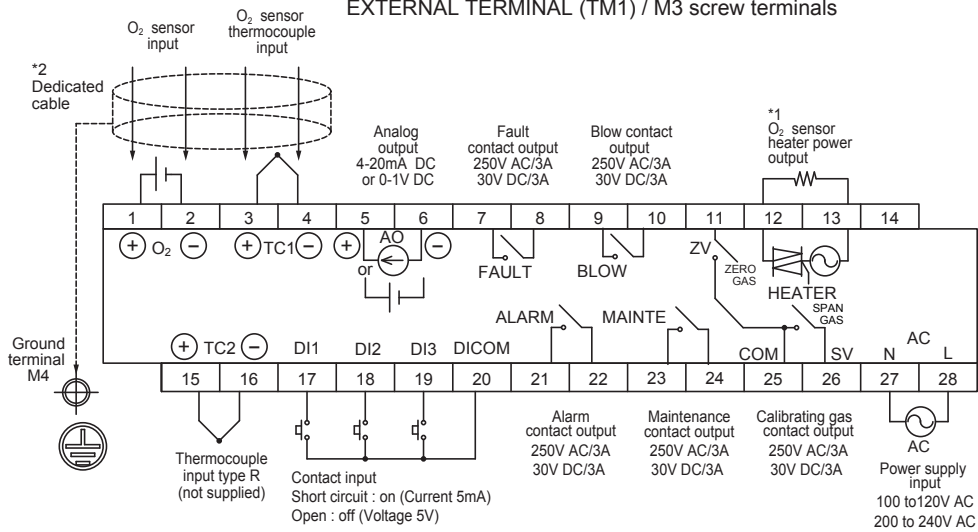

RS-485 communication terminal (TM2, option) / Euro-style terminals

1	2	3
GND	TRX-	TRX+

Notes:

- *1. The heater uses the same power source as the converter.
- *2. Connect the shield of the dedicated cable to the ground terminal inside the converter.
- *3. HART communication (option) uses the 4–20 mA analog output line.

Converter (ZKMB)
 <IP67 enclosure> with selector valve

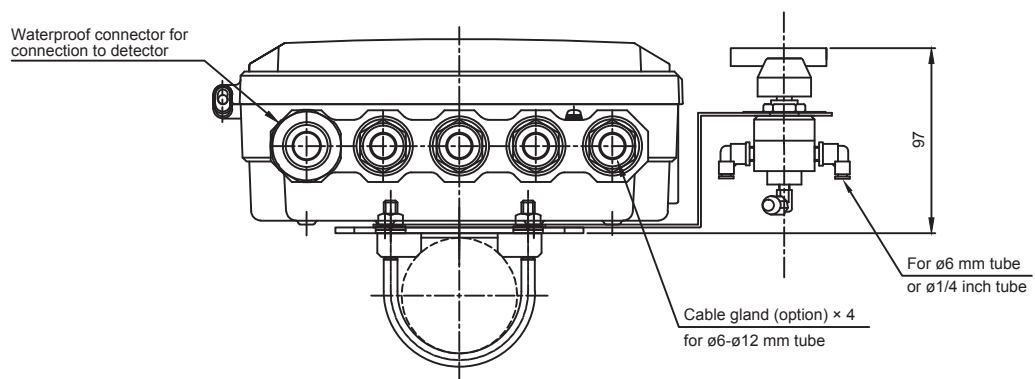
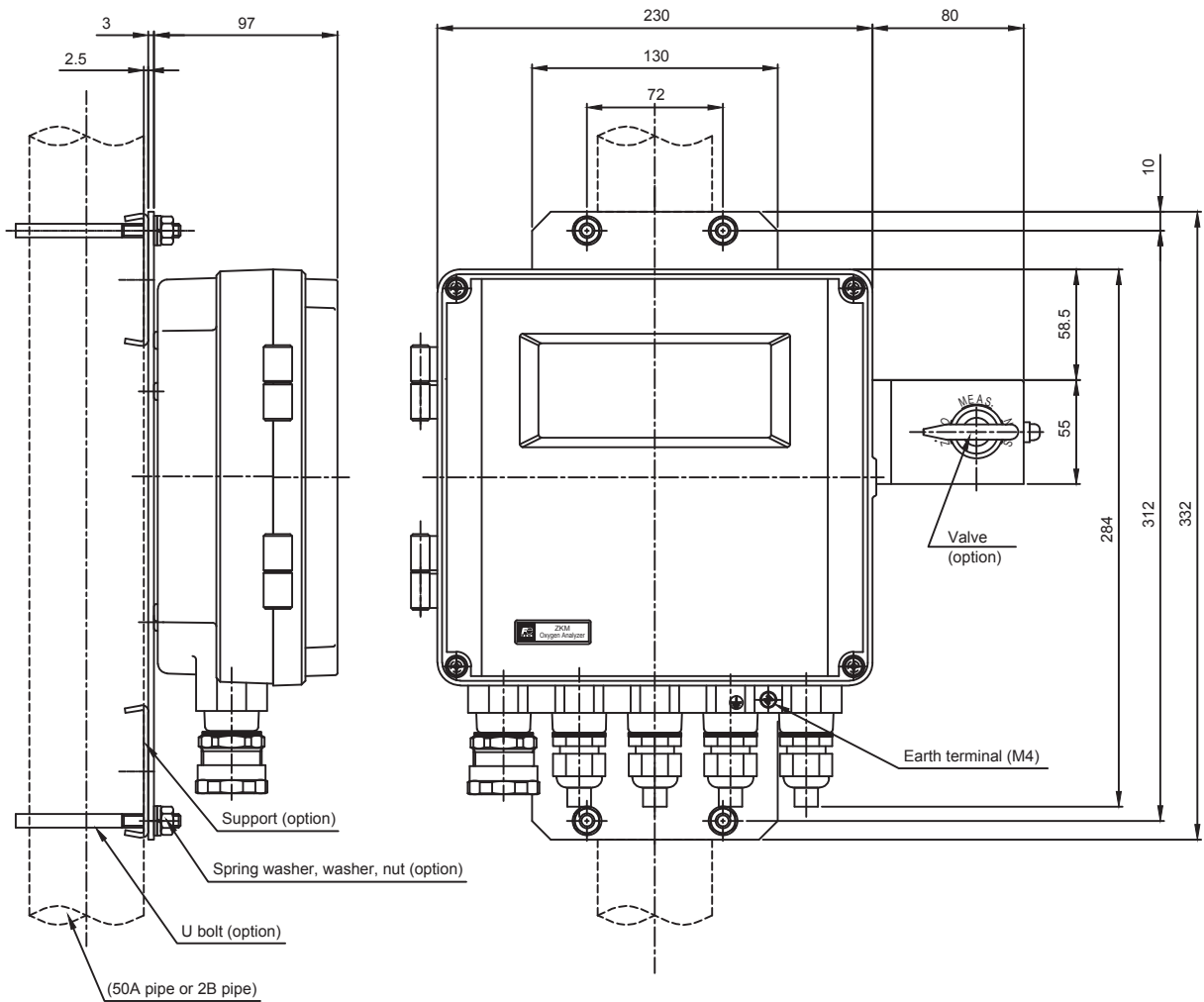

Converter (ZKMB)

<IP67 enclosure> with selector valve and flowmeter

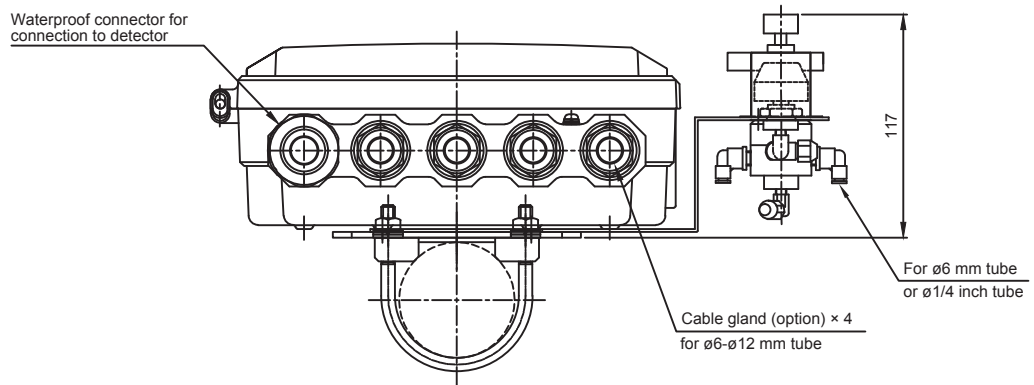
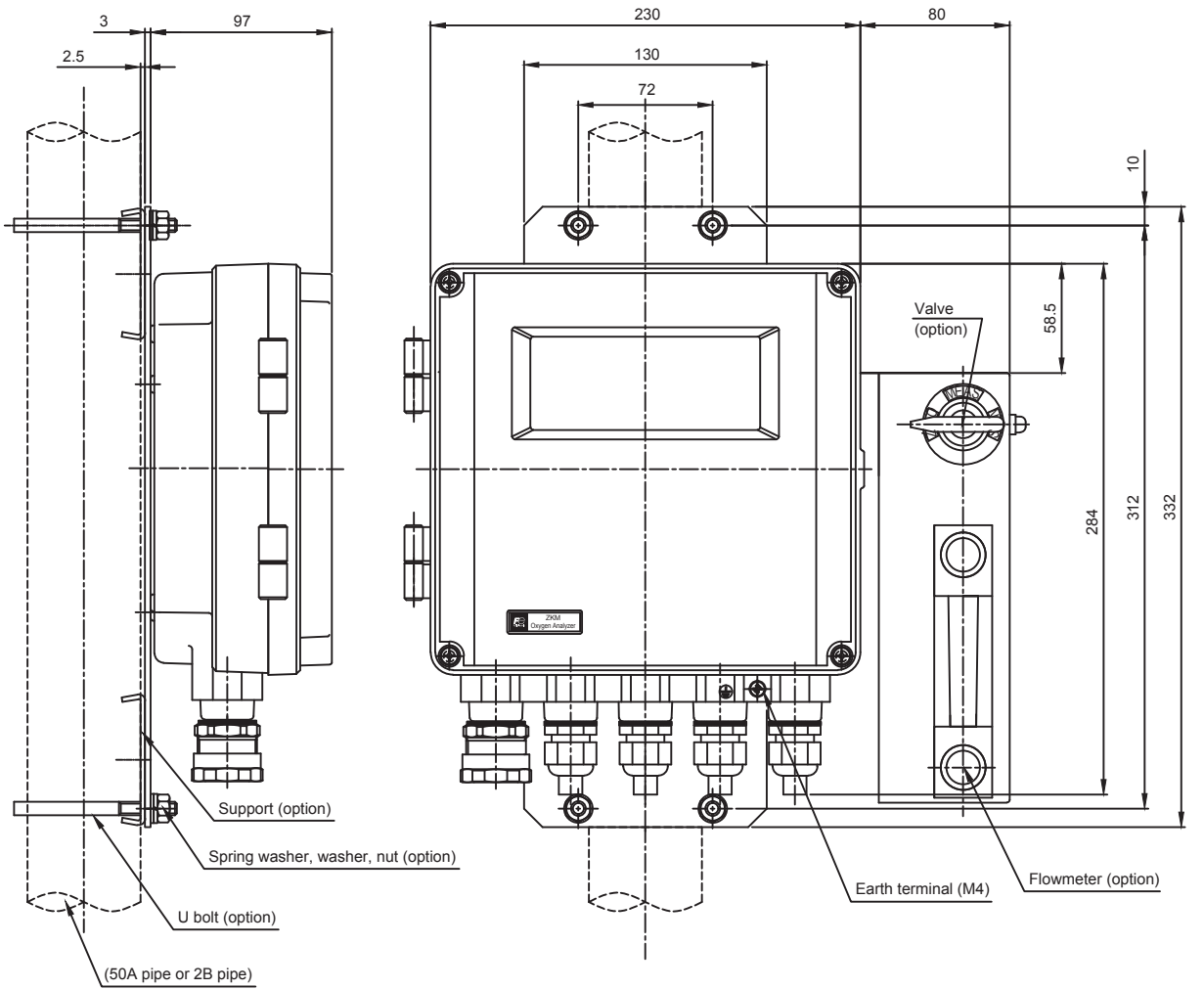

⚠ Caution on Safety

*Before using this product, be sure to read its instruction manual.

 Fuji Electric Co., Ltd.

Instrumentation & Sensors Planning Dept.
1, Fuji-machi, Hino-city, Tokyo 191-8502, Japan
<http://www.fujielectric.com>
Phone: +81-42-514-8930 Fax: +81-42-583-8275
<http://www.fujielectric.com/products/instruments/>