

- › **16 Input Channels**
Isolated Universal inputs, **OR**
Non-Isolated RTD inputs
- › **Modbus option**
For easy integration with
SCADAs and PLCs
- › **4 Digital inputs**
- › **Auto-detecting RS232/
RS485 serial port**
- › **Easy USB programming**
[defineinstruments.com/
workbench](http://defineinstruments.com/workbench)

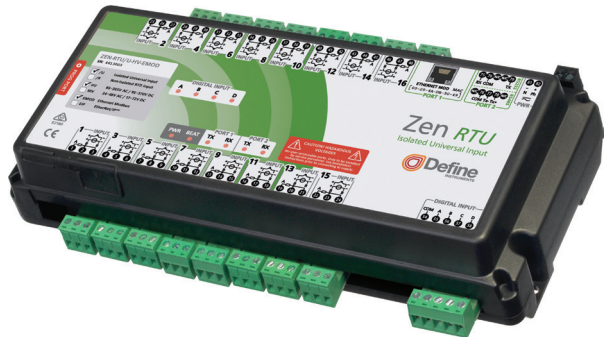

General Description

The **Zen RTU/U** is a Remote Terminal Unit made for harsh industrial environments. Each channel is isolated and EMC hardened. The universal input is one of the most flexible on the market, making it a breeze to interface to a wide range of sensors.

The **Zen RTU/R** provides a lower cost, non-isolated temperature (RTD) only version, suitable for more benign applications like cool store monitoring.

Both units have 16 input channels, enabling you to collate a large number of signals, and simply and efficiently route them to your PLC or SCADA system.

Our free WorkBench configuration software is designed to assist and even teach you how to configure the unit, and provides a range of easy-to-use presets and flexible controls. The intuitive help panel follows you during setup and updates automatically with relevant tips, wiring diagrams, and application examples.

CONTENTS

Contents	2	6.4 - Thermocouple input	24
Order Codes	3	6.5 - Digital pulse	25
Safety Notices	3	6.6 - Potentiometer input	26
1 - Specifications	4	6.7 - AC current sensor	27
2 - Dimensions & Installation	6	6.8 - Attenuator	27
2.1 - Case dimensions	6	7 - Connecting To A PLC	28
2.2 - Installation environment	6	7.1 - Zen registers	28
2.3 - Installation instructions	7	8 - Maintenance	29
2.4 - EMC installation guidelines	8	8.1 - Calibration	29
3 - Installing Define WorkBench	9	8.2 - Troubleshooting	29
4 - Software Configuration	11	A - Appendix A - EMC Test Results	30
4.1 - Connecting	11		
4.2 - WorkBench interface overview	12		
4.3 - Main navigation	13		
5 - Wiring & LED's	14		
5.1 - Zen RTU terminals	14		
5.2 - LED indicators	16		
5.3 - Digital inputs	16		
5.4 - Port 1 (optional)	18		
5.5 - Port 2	18		
6 - Input Wiring & Specifications	19		
6.1 - Current input	19		
6.2 - Voltage input	21		
6.3 - RTD input	23		

Symbol definitions



CAUTION
Risk of electric shock
Please refer to user manual.



CAUTION
Risk of danger
Please refer to user manual.



Both direct and alternating current.



Equipment protected throughout by
DOUBLE INSULATION or REINFORCED
INSULATION.

ORDER CODES

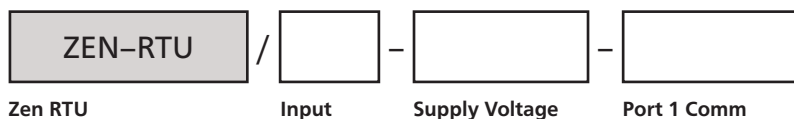

Input	U R	16 x Isolated Universal Inputs 16 x Non-isolated RTD Inputs
Supply Voltage	HV MV	85–265V AC / 95–370V DC 24–48V AC / 17–72V DC
Port 1 Comm	EMOD	No Port 1 Comm Ethernet Modbus

SAFETY NOTICES



For your safety and the prevention of damage to the Zen unit and other equipment connected to it, **please read complete instructions prior to installation and operation of the Zen and carefully observe all safety regulations and instructions. Consult this manual carefully in all cases where hazard symbols are marked on your Zen unit.**



Use of this instrument in a manner not specified by the manufacturer may compromise the protection provided by the instrument. This instrument should not be used to directly drive valves, motors, or other actuators, unless equipped with appropriate safeguards.

It is the responsibility of the user to identify potential hazards that may arise in the event of a fault to unit, and implement safeguards for the prevention of harm to persons or equipment. The safety of any system incorporating this unit is the responsibility of the assembler of the system.

1

SPECIFICATIONS

Power

Power supply

HV= 85–265V AC / 95–370V DC, **OR**
 MV= 24–48V AC / 17–72V DC

Supply frequency 50/60Hz, 10VA

Mains isolation 250V AC

Mains isolation test voltage to all inputs and outputs 3000V AC 50Hz for 1min

General specifications

Linearity & repeatability $<\pm 0.1\%$ FSO

Channel separation 125db minimum

Noise immunity (CMRR) 160dB tested at 300V RMS 50Hz

RF immunity $<\pm 1\%$ effect FSO typical

Permanent memory (E²ROM) 100,000 writes per input parameter

Analog input ZEN-RTU/U

16x Isolated Universal Inputs

See Section 6 for specifications and wiring

Input isolation 2,500V AC 1 minute between all input channels

Isolation test voltage 1000V DC for 1min (Analog input to analog input)

Input resolution 16 bits

Accurate to $<\pm 0.1\%$ FSO (unless otherwise stated in Section 6)

Analog input ZEN-RTU/R

16 x Non-Isolated RTD Inputs

See 6.3 for specifications and wiring

Input isolation Not isolated

Input resolution 16 bits

Digital input

4 x Opto isolated inputs with LED indication of each input

Functions Status, up counter, up/down counter with direction, debounced counter, frequency, gated frequency

Counter register output 32 bit

Frequency range 0–10,000Hz

Input voltage 5–30V DC

Threshold 4.6V typical

Debounce counter range 0–100Hz

Load At 5V DC: 1.1mA; At 24V DC: 7mA

Isolation test voltage 1000V DC for 1min (Digital input to analog input)

Comms

Protocols Modbus RTU, RS232 or RS485

Port 1 Select either:

No Port 1 Comm **OR**

EMOD= Ethernet Modbus (10/100/Auto)

Port 2 RS232 / RS485 auto-select

Selectable baud rate 2400–230000 baud

Format 8 bit, no parity, 1 stop

Isolation test voltage 1000V DC for 1min
between comms and analog/digital input

Programming

USB programmable Via USB prog port
using Bridge Key USB programmer (sold
separately)

Define WorkBench Simple configuration
using Define WorkBench. Free download at:
defineinstruments.com/workbench

Construction

Casing DIN 35 rail mounting; Material: ABS
inflammability V0 (UL94)

Dimensions (H x W x D, with plugs in)
2.32 x 10.04 x 5.67" (59 x 255 x 144mm)

Unit weight ZEN-RTU/U = 25.8oz (730g)
ZEN-RTU/R = 24.6oz (696g)
EMOD or EIP = Add 0.2oz (6g)

Environmental conditions

Operating temp 14 to 140°F (–10 to 60°C)

Storage temp –4 to 176°F (–20 to 80°C)

Operating humidity 5–85% RH max,
non-condensing

Compliances

EN-61326-1:2006

EMC Emissions EN 558022-A;
Immunity EN 50082-1; **Safety** EN 60950

2

DIMENSIONS & INSTALLATION

2.1 - Case dimensions

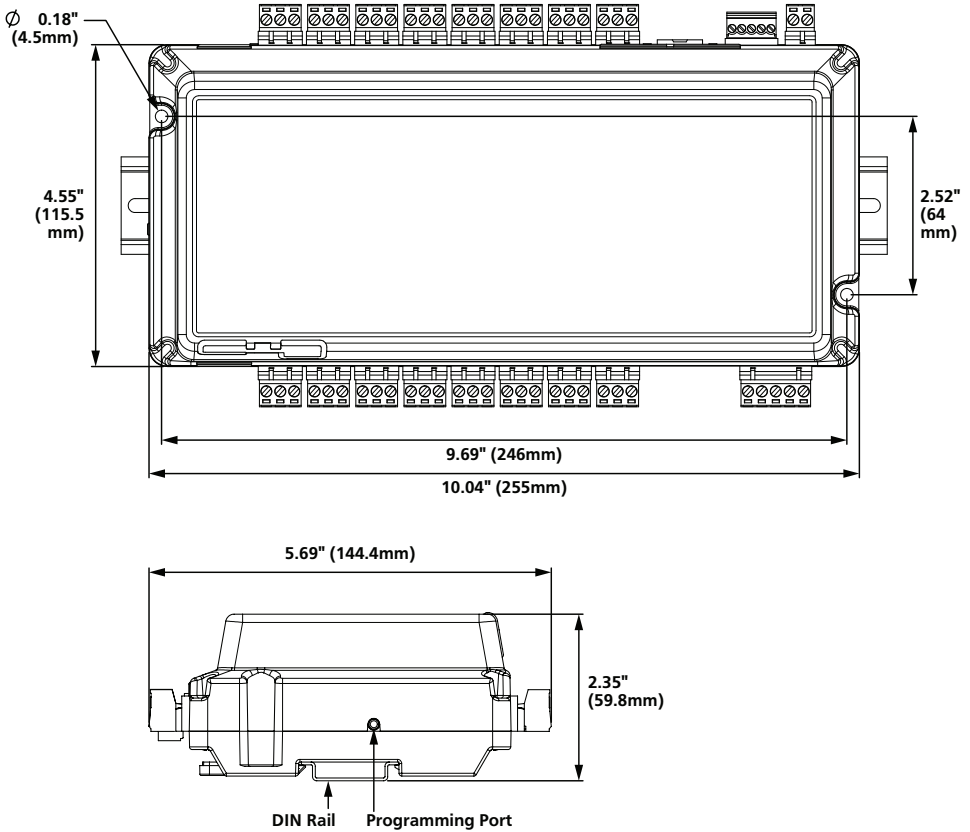

2.2 - Installation environment

The Zen should be installed in a location that does not exceed the maximum operating temperature, and at a safe distance from other devices that generate excessive heat. The installation environment should provide good air circulation to the unit.

The plastic casing and product label may be cleaned, if required, using a soft, damp cloth and neutral soap product. **Caution should be exercised when cleaning the unit to avoid water dripping inside, as this will damage the internal circuits.**

2.3 - Installation instructions

The Zen RTU is rated IP20, and should be mounted in an enclosure to protect the unit from weather conditions and dust.

A - Installation in Enclosure (Fig 1)

Prepare an **Enclosure** (not supplied) as illustrated by mounting a **DIN 35 rail**, cable glands, and any other required components.

If using a metal enclosure, the enclosure must be earthed.

B - DIN Rail Mounting (Fig 2)

To clip the unit onto the DIN rail:

- (1) Hook the lower part of the unit onto the rail, and then
- (2) Press down towards the rail until the red hooks click into place

Leave at least 2" (5cm) clear above and below the unit, to allow room for airflow and wiring.

C - Wiring

Refer to Sections 5–6 in this manual.

D - Removal from DIN Rail (Fig 3)

To remove the unit from the DIN rail:

- (1) Power down the unit
- (2) Unplug the 'Input 4' and 'Port 1' connectors from the top of the Zen (the DIN clips are behind these terminals)
- (3) Gently pull the unit away from the rail while levering one of the clips upward with a screwdriver
- (4) When one side is loosened, hold it slightly away from the rail to prevent the clip from engaging again (pictured in Fig 3). Meanwhile, lever the second clip upward as you did with the first.

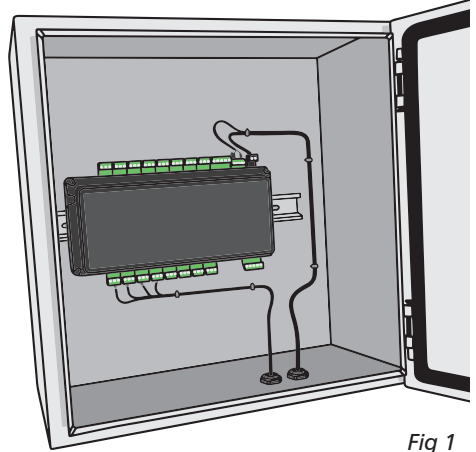

Fig 1

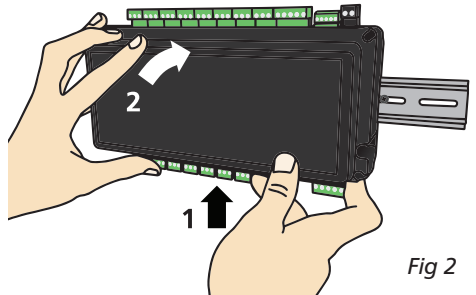

Fig 2

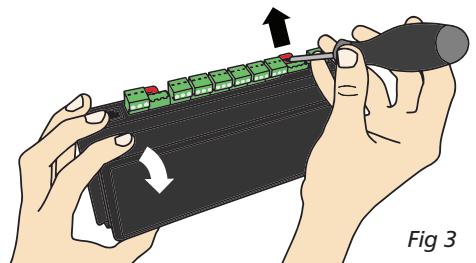

Fig 3

2.4 - EMC installation guidelines

The Zen has been designed to cope with large EMC disturbances. This has been achieved by continual testing and improvement of filtering and layout techniques over many years.

The Zen meets CE noise requirements, and even surpasses them in many tests. (For full details and test results, see Appendix A.) However in some applications with less than optimum installations and large power switching, the EMC performance of the Zen can be further improved, by:

- A** Installing the unit in an earthed **Metal Enclosure**. This is particularly useful if the control box is mounted close to large power switching devices like contactors. Every switching cycle there is a possibility of generating a large amount of near field radiated noise. The **Metal Enclosure**, acting as a faraday cage, will shunt this radiation to ground and away from the Zen.
- B** Increasing the physical distance from the power devices. For example, increasing the control box distance from 6" to 12" from the noise source will reduce the noise seen by the control box by a factor of 4. (Probably the cheapest and best results in this situation could be obtained by adding RC snubbers to the contactors or power switches.)
- C** Using shielded cable on sensitive input and control signal lines. Good results can be obtained by grounding the shields to the metal enclosure close to the entry point. All cables act as aerials and pick up unwanted R.F. radiated signals and noise; the earthed shield acts as a faraday cage around the cables, shunting the unwanted energy to ground.
Shields can also help with capacitively coupled noise typically found in circumstances when signal cable is laid on top of noisy switching power cables. Of course in this case you are better off to keep separate signal and power lines.
- D** Laying cable on earthed cable trays can also help reduce noise seen by the Zen. This is particularly useful if there are long cable runs, or the unit is close to radiating sources such as two way radios.
- E** The relay outputs of the Zen have built in MOV's to help reduce EMI when switching inductive loads. EMI can further be reduced at the load by adding snubbers for AC signals or a flyback diode for DC coils.

3

INSTALLING DEFINE WORKBENCH

Define WorkBench offers a comprehensive and yet simple-to-use setup tool for your Zen RTU.

You must install WorkBench before connecting the Zen RTU to your computer. If you have already connected using the Bridge Key, please disconnect before continuing.

- A Download the latest version of WorkBench from defineinstruments.com/workbench
- B Extract the install file from the zip folder. Right-click on the zip folder and choose 'Extract All', (or extract the file using another extraction utility of your choice).

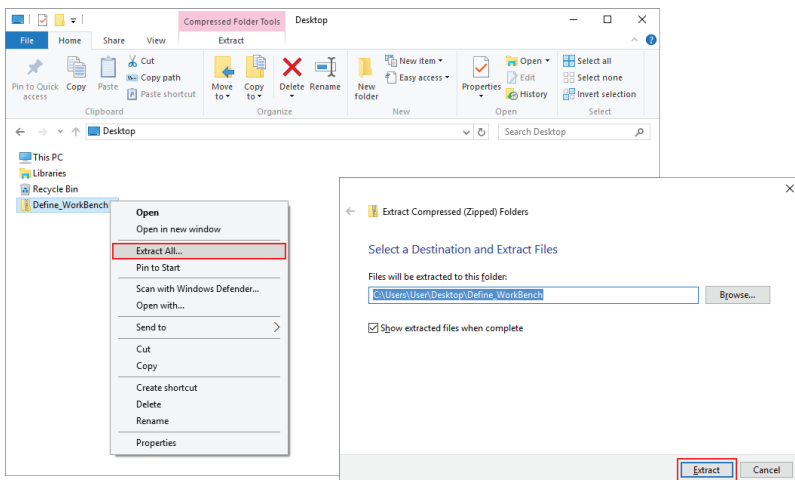

- C Double-click on the extracted .msi install file. This will launch the WorkBench installer. Depending on your security settings, a 'Security Warning' dialog may appear. If you see the security message, click 'Run'.

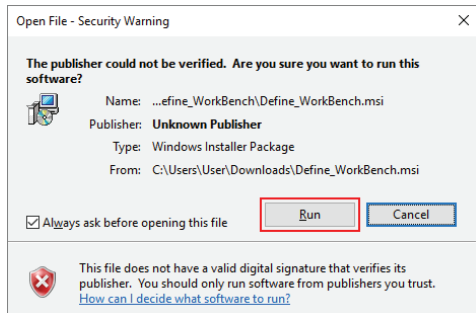

- D** The WorkBench setup wizard will launch. Click 'Next' to get started.

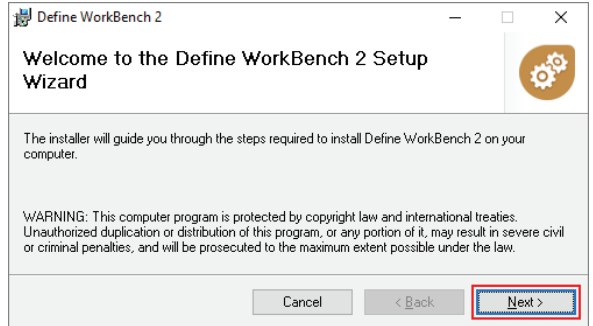

- E** The wizard will also ask for confirmation that you wish to begin the installation. Click 'Next' to continue.

- F** The wizard will then prompt you to select an installation folder.

You may accept the default installation folder, or select an alternative location by clicking 'Browse'.

Click 'Next' to continue.

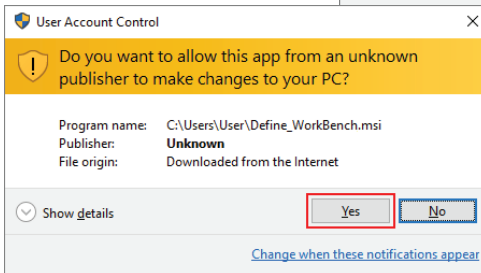
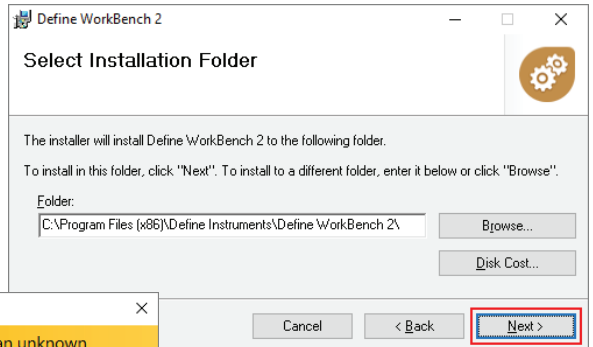

- G** Depending on your security settings, the 'User Account Control' dialog may appear. If it does, simply click 'Yes' to allow the program to be installed on your computer.

- H** The install wizard will now install Define WorkBench. Please wait. This process usually takes 2–3 minutes, but may take longer in some situations.

- I** When the installation has successfully completed, the following dialog will appear. Click 'Close' to exit.

The installer will place an icon on your desktop for easy access to WorkBench.

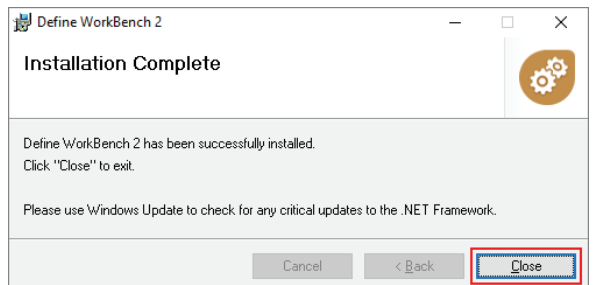

4 SOFTWARE CONFIGURATION

4.1 - Connecting

Connect the Bridge Key

To program your Zen RTU, connect one end of the **Interface Cable** to the programming port on the left side of the Zen (see Fig 4), and the other end to your **Bridge Key**.

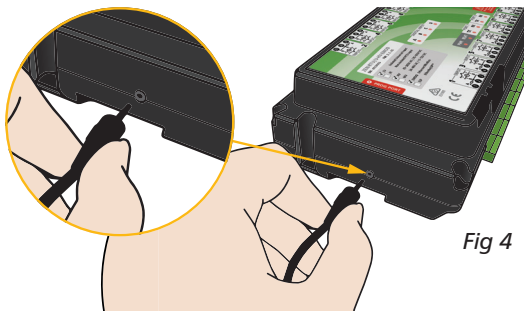

Fig 4

Then plug the **Bridge Key** into your computer's USB port (see Fig 5).

Supply Power

Supply power to the Zen RTU, referring to 5.1 for wiring.

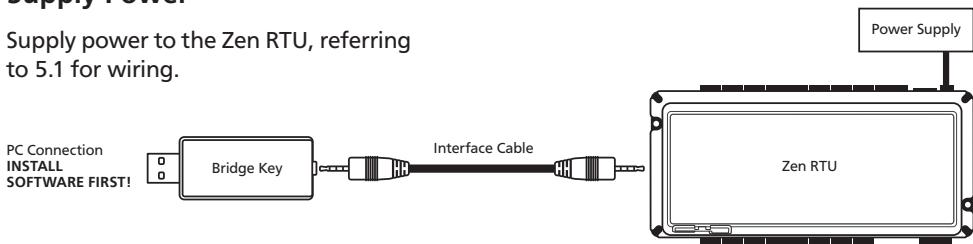
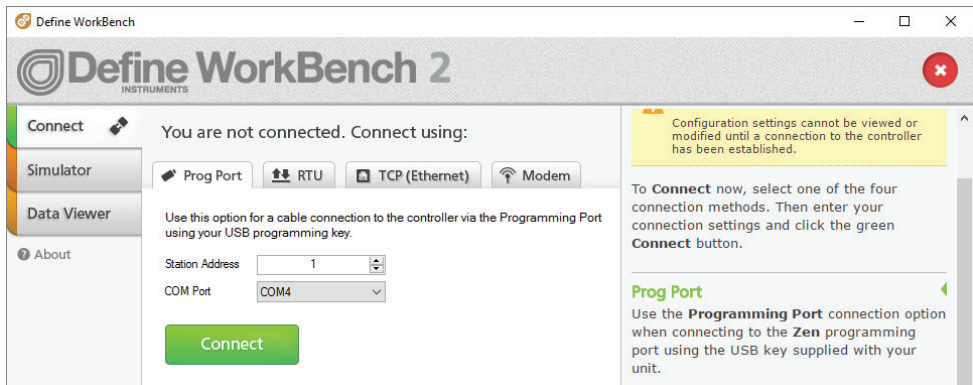

Fig 5

Connect to your Zen in Define WorkBench

Launch Define WorkBench (see Section 3 for installation instructions), and select the 'Prog Port' tab. If your Zen is powered up and connected via the Bridge Key, then the COM Port will be detected automatically. Click 'Connect'.



4.2 - WorkBench interface overview

Main Navigation, including channel sub-navigation. See 4.3 for more information.

Control Area

Main control area for configuring your system. Any changes made in this area will bring up the **Apply Button** (see below)

Connection Panel

Disconnect button
Connection status

The screenshot displays the Define WorkBench 2 software interface. On the left is the **Main Navigation** pane with a list of tabs: Overview, Ports, Inputs, Digital Inputs, Totalizers, and Plugins. The **Control Area** in the center shows configuration for 'Input 1', including fields for Input Value (100.1), Input Name (100 Ohm Ref), Input Mode (mA), Input Range (4-20mA), and various adjustment options. A purple bar at the bottom of the Control Area indicates 'Your configuration has unapplied changes' and features an **Apply Button**. On the right, the **Connection Panel** shows 'Connected: COM3' with a 'Disconnect' button and a green checkmark. Below this, the **Help Panel** displays 'Input Mode & Type/Range' options and a wiring diagram for a 0/4-20mA current loop with terminals A+, B+, and B-.

Apply Button

Appears if you have made any changes in the **Control Area**. WorkBench will not allow you to browse to a new tab in the **Main Navigation** with unapplied changes to your configuration.

Help Panel

Wiring diagrams, explanations and helpful tips will automatically appear in this panel as you configure the Zen.

4.3 - Main navigation

Overview

View basic device information including Serial Number and firmware version. Password Protect your device, export a configuration certificate and save/upload a configuration file.

Ports

This tab is only visible if you are connected to your Zen via the USB Programming Port. It enables you to configure a range of settings for Port 1 and Port 2 (baud rate, parity, Tx delay etc.).

Once your ports are set up, you will be able to configure to your Zen in WorkBench via Port 1 or Port 2 instead of the USB programming port - perfect for adjusting settings once your unit is installed.

Inputs

Set up and scale the 16 input channels. Includes integrated wiring diagrams and examples.

Digital Inputs

Set up the four digital inputs and view their live status.

Totalizers

Configure up to 10 totalizers using either an input channel or a digital input as the source.

Totalizers are only available for the Zen RTU/U.

Plugins

Plugins are small programs which are loaded into the Zen to expand its functionality or simplify its use. Plugins are optional and in many cases they may not be needed. Note that only one plugin can be installed on your Zen at a time.

5

WIRING & LED'S

5.1 - Zen RTU terminals

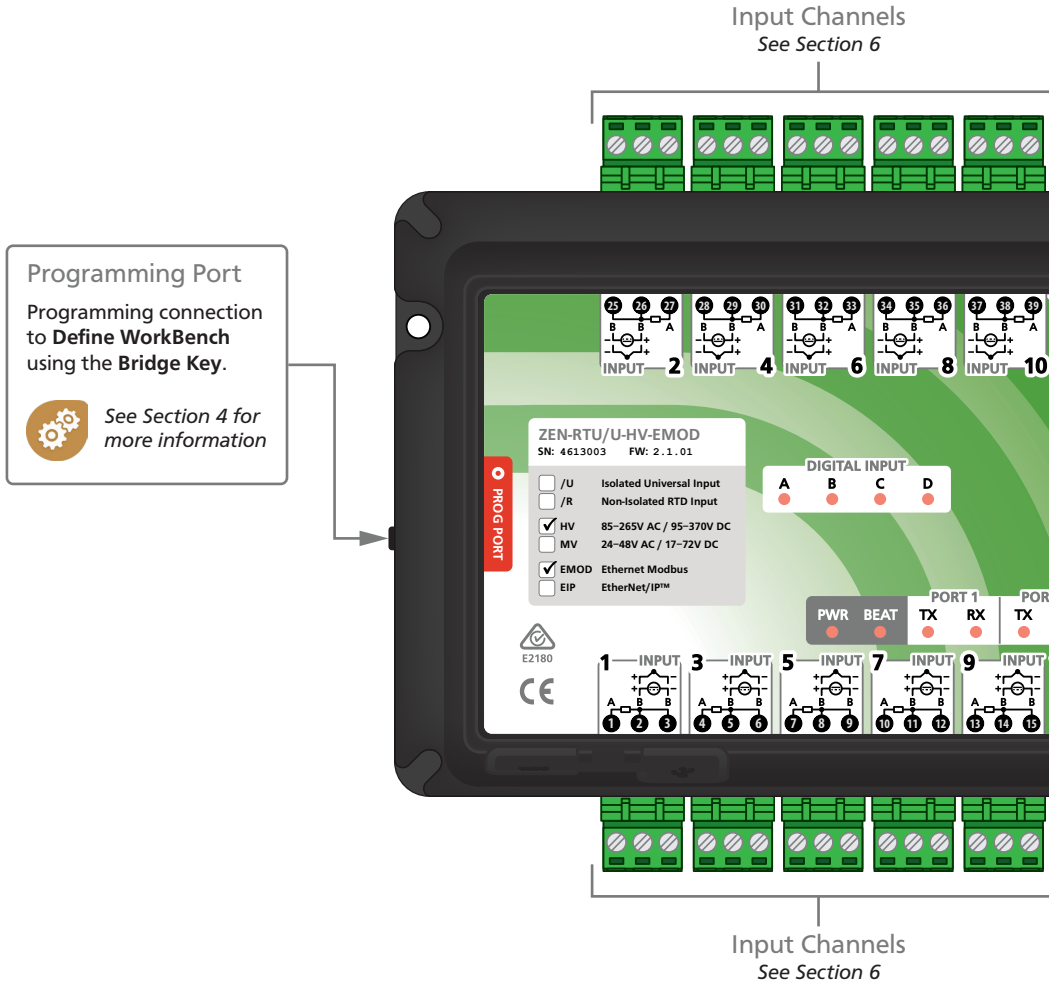

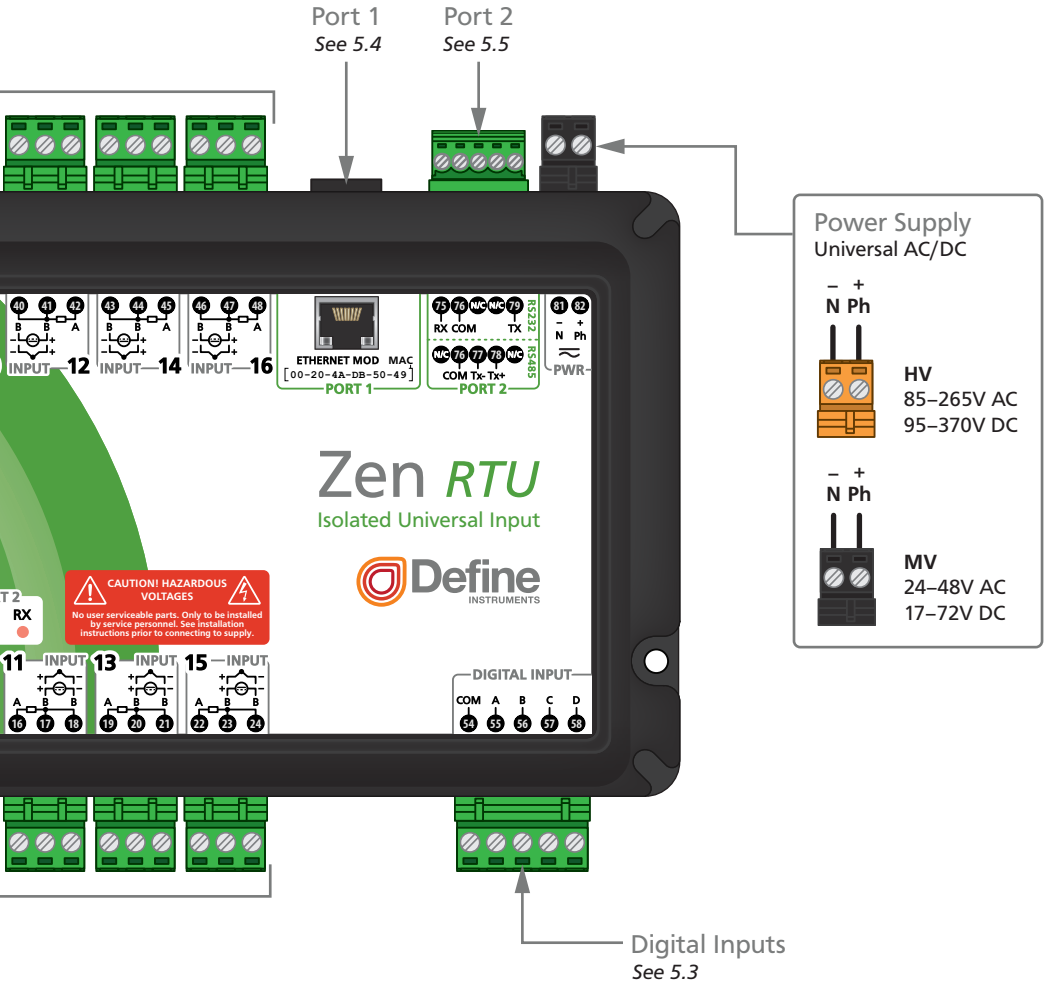

5.2 - LED indicators

The Zen RTU has 10 LED indicators on the top label (or 8, for units with no comms option installed in Port 1). These LED's provide information about the unit's status, as explained below:

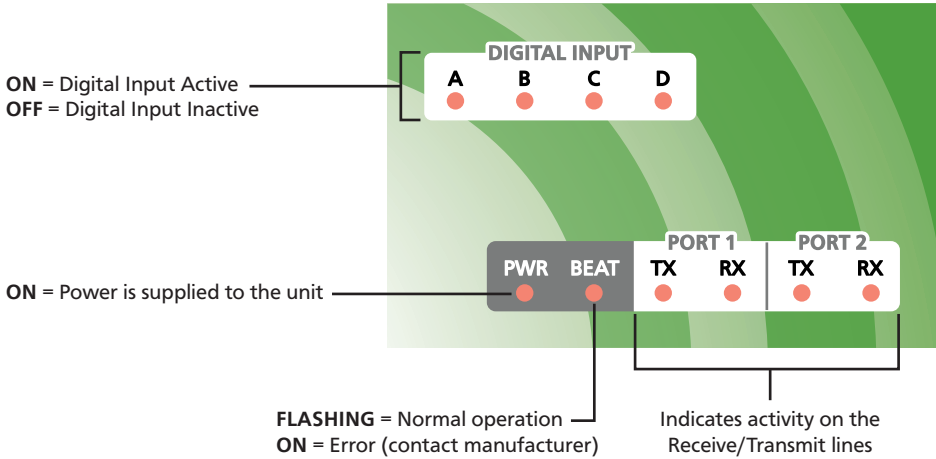

5.3 - Digital inputs

The Zen RTU has four Digital Inputs (A–D), each with LED indication on top of the unit. The digital inputs can be configured and scaled using Define WorkBench from the "Digital Inputs" tab, as per the list below:

- > **Status** (active/inactive - can be read by a SCADA system as a general digital input)
- > **Counter** (up to 10KHz, or 100Hz Debounced)
- > **Frequency** (up to 10KHz)
- > **Flow count** (up to 10KHz)
- > **Flow rate** (up to 10KHz)
- > **RPM** (up to 10KHz)

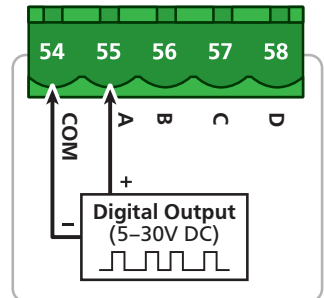

NOTE

For the Zen RTU/U, the universal analog inputs can also be wired as digital pulse inputs (see 6.5).

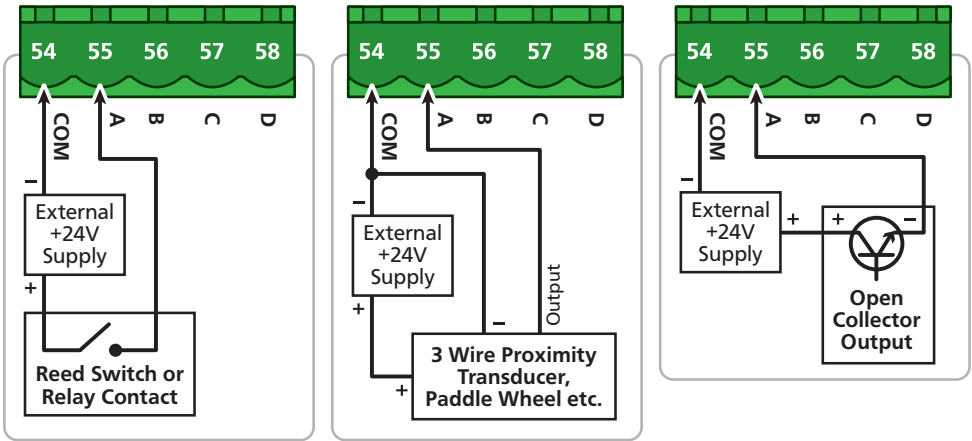

Connection example for digital inputs (A-D)

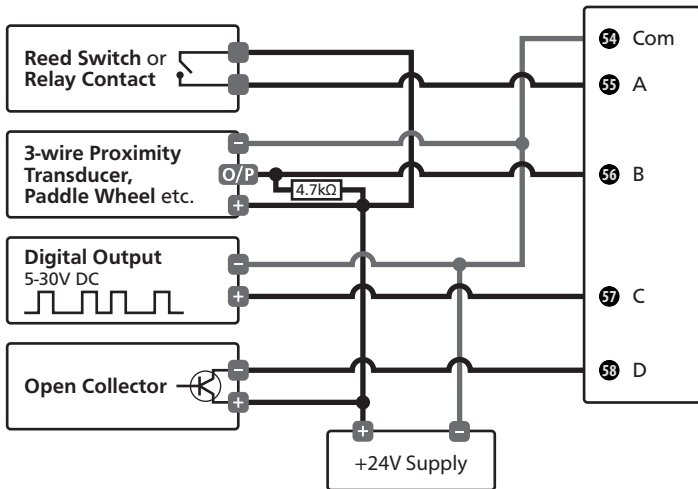

Note 1 All cables must be screened, with screen earthed at one end only.

Note 2 Do not fit the 4K7 resistor for 3-Wire PNP transducers.

5.4 - Port 1 (optional)

Port 1 on the Zen RTU is optional. If filled, the option is Ethernet Modbus.

5.5 - Port 2

Port 2 can be wired for either RS232 or RS485 serial connection, as shown (right).

**NOTE**

Pins marked 'NC' MUST be left disconnected to ensure correct auto-detection of your comm type.

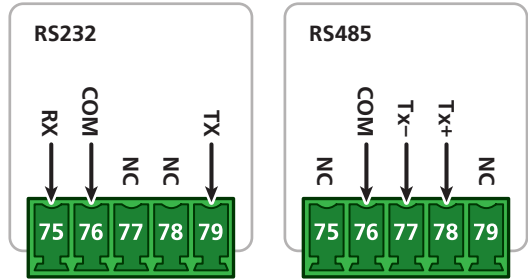

6 INPUT WIRING & SPECIFICATIONS



CAUTION

Risk of electric shock. Dangerous and lethal voltages may be present on the input terminals. Please take appropriate precautions to ensure safety.



CAUTION

Risk of danger. The sensor input can potentially float to dangerous and unexpected voltages depending on what external circuit it is connected to. Appropriate considerations must be given to the potential of the sensor input with respect to earth common.

6.1 - Current input

Zen RTU/U

Range 0–20mA, 4–20mA

Input impedance 45Ω

Maximum over-range protected by PTC to 24V DC

Accuracy 0.1% FSO max

Linearity & repeatability 0.1% FSO max

Channel separation 0.001% max

Ambient drift 0.003%/°C FSO typical

RF immunity 1% effect FSO typical

0/4–20mA DC is the most commonly used analog signal in industry, and is universally accepted. As a current loop, it is unaffected by voltage drops in cables, and can be transmitted over long distances without signal degradation. Current input is accepted by the Zen RTU/U only.

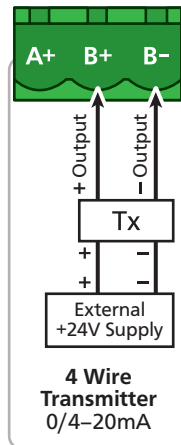
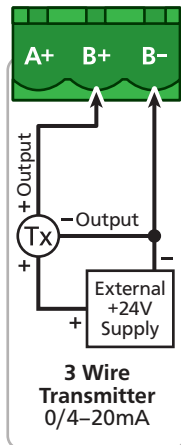
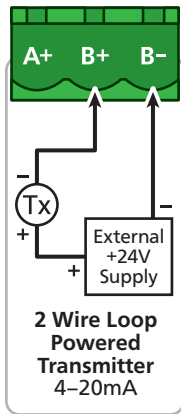
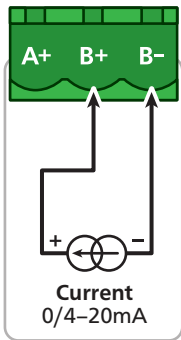

Fail-Safe Micro Switch

If you are connecting other instruments in a loop with a Zen mA input, a fail-safe has been added to prevent the external loop from being interrupted in the event of a power loss to the Zen.

To activate the fail-safe for an input channel, turn on the micro switch above the input terminal. You will need to remove the input connector to see the switch, and use a small screwdriver to turn it on.

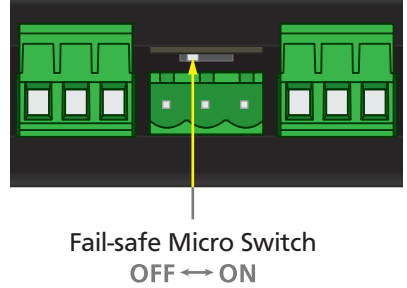

NOTE

The Fail-Safe Micro Switch is only compatible with mA inputs on the Zen RTU/U. For the accurate operation of this instrument, it is critical that the micro switch be set to the OFF position for all other input types.

Connection example for 2, 3 & 4 wire mA output transmitters

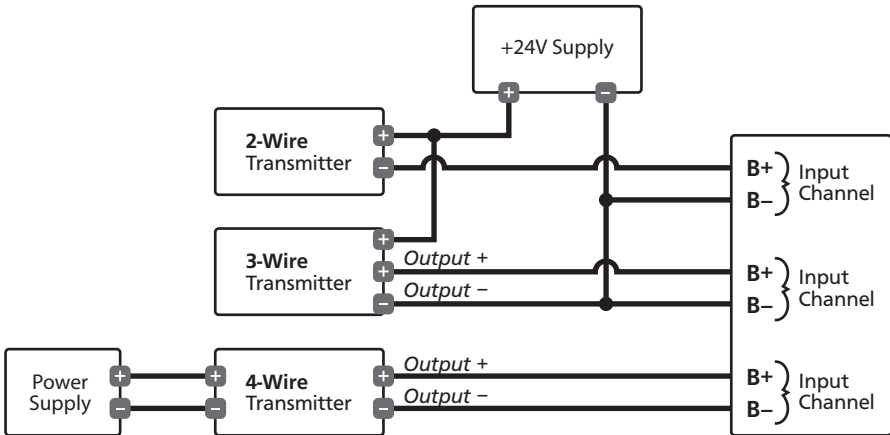

Note 1 All analog inputs are isolated to other channels and all other voltages. They also have built in over voltage protection to 24V, protecting the unit if the 24V supply is inadvertently connected to the unit when configured for mA input.

Note 2 All cables must be screened, with screen earthed at one end only.

Note 3 Do not run input cables in close vicinity to noisy power supplies, contactors or motor cables. The best practice is to run input cables on a separate earthed cable tray. This will minimise RFI effects, of which magnitude cannot be easily predicted.

6.2 - Voltage input

Zen RTU/U

Ranges $\pm 200\text{mV}$, -200mV to 1V ,
 $0-10\text{V}$, $0-18\text{V}$

Input impedance $>500\text{K}\Omega$ on all ranges

Maximum over-voltage 24V DC

Accuracy 0.1% FSO max

Linearity & repeatability 0.1% FSO max

Channel separation 0.001% max

Ambient drift $0.003\%/^{\circ}\text{C}$ FSO typical

RF immunity 1% effect FSO typical

The Zen RTU/U accepts both voltage and millivolt inputs. Along with the standard $0-10\text{V DC}$ range, a variety of other ranges are provided to suit a various applications. These can all be selected using the WorkBench software and easily scaled into engineering units.

The $\pm 200\text{mV DC}$ and -200mV to 1V DC ranges are ideal for low signal applications, such as measuring large DC currents using external current shunts, or interfacing to sensors with low voltage output. A $0-18\text{V}$ general purpose voltage range is also provided.

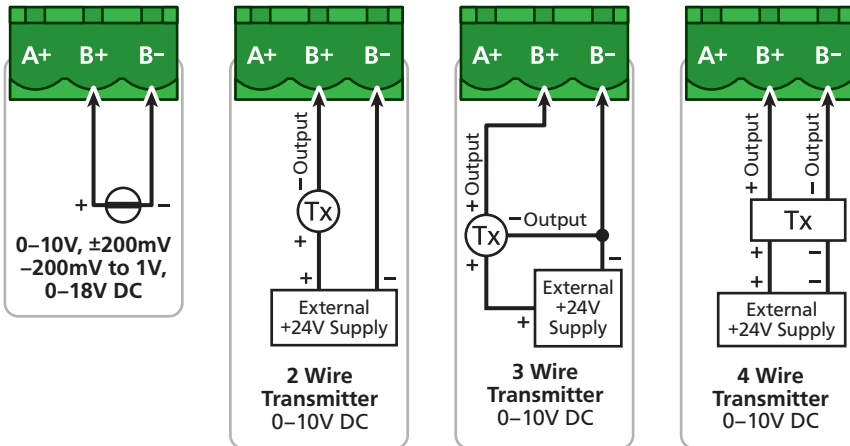

Connection Example for Millivolt & Voltage Inputs for 2, 3 & 4 Wire Transmitters

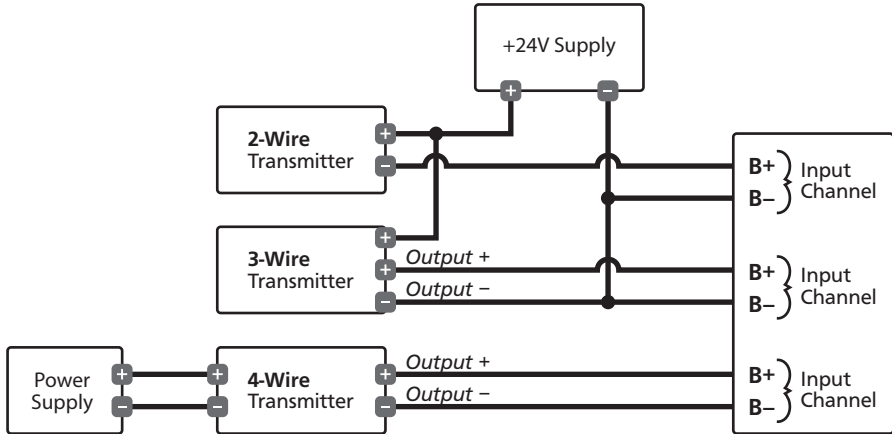

Note 1 Each voltage input must not see more than 18V peak between the negative and the input, otherwise permanent damage may occur.

Note 2 All cables must be screened, with screen earthed at one end only.

Note 3 Do not run input cables in close vicinity to noisy power supplies, contactors or motor cables. The best practice is to run input cables on a separate earthed cable tray. This will minimise RFI effects, of which magnitude cannot be easily predicted.

6.3 - RTD input

RTD Pt100 3 wire RTD DIN 43760: 1980

RTD Pt1000 3 wire RTD standard

Resolution

-328–572°F (-200–300°C) = 0.02°F (0.01°C)

-328–1472°F (-200–800°C) = 0.1°F (0.1°C)

Lead resistance 10Ω/lead max recommended

Sensor current 0.6mA continuous

Zen RTU/R

Zen RTU/U

Sensor fail upscale

Accuracy (RTU/R)

-328–572°F (-200–300°C) = $\pm 0.2^{\circ}\text{C}$

-328–1472°F (-200–800°C) = $\pm 0.3^{\circ}\text{C}$

Accuracy (RTU/U)

-328–572°F (-200–300°C) = $\pm 0.1^{\circ}\text{C}$

-328–1472°F (-200–800°C) = $\pm 0.3^{\circ}\text{C}$

Ambient drift 0.003°C/°C typical

RTD input is accepted by both the **Zen RTU/R** and the **Zen RTU/U**. The RTD is highly stable and accurate. Often referred to as Pt100 and Pt1000, the Pt represents platinum, and 100/1000 is the resistance in ohms at 0°C.

Supported RTD types/ranges

Pt100/Pt1000 (0.02°F/0.01°C res) -328 to 572°F (-200 to 300°C)

Pt100/Pt1000 (0.1°F/0.1°C res) -328 to 1472°F (-200 to 800°C)

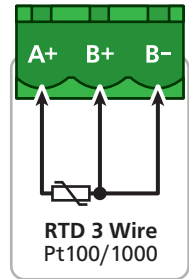

Connection Example for 3-Wire RTD Inputs

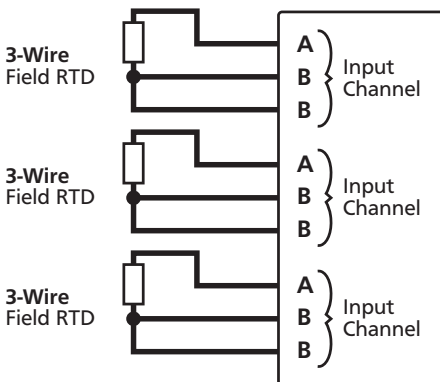

Note 1 Inputs are isolated for the Zen RTU/R, and non-isolated for the Zen RTU/U.

Note 2 All RTD cables must be screened, with screen earthed at one end only. All three wires must be the same resistance (i.e. the same type and size).

Note 3 To minimise lead resistance errors, 3-wire RTD's should be used. Offset errors for 2-wire RTD's may be compensated for in the software.

Note 4 Do not run input cables in close vicinity to noisy power supplies, contactors or motor cables. The best practice is to run input cables on a separate earthed cable tray. This will minimise RFI effects, of which magnitude cannot be easily predicted.

6.4 - Thermocouple input

Zen RTU/U

Thermocouple types B, E, J, K, N, R, S or T type (see table below for ranges)

Cold junction compensation 14 to 140°F (-10 to 60°C)

CJC drift <0.02°C/°C typical for all inputs

Sensor open Upscale

TC lead resistance 100Ω max

Input impedance >500KΩ

Accuracy 0.1% of FSO ±1°C typical

The thermocouple is one of the most common temperature sensors used in industry. It relies on the Seebeck coefficient between dissimilar metals. The thermocouple type is selected with reference to the application temperature range and environment, with J and K type being the most common.

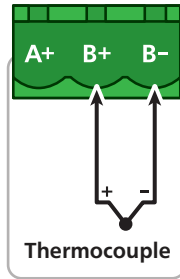

Supported thermocouple types/ranges

B	32 to 3272°F	(0 to 1800°C)
E	-328 to 1292°F	(-200 to 700°C)
J	-328 to 1832°F	(-200 to 1000°C)
K	-328 to 2300°F	(-200 to 1260°C)
N	-328 to 2372°F	(-200 to 1300°C)
R	32 to 3092°F	(0 to 1700°C)
S	32 to 3092°F	(0 to 1700°C)
T	-328 to 752°F	(-200 to 400°C)

Connection Example for Thermocouple Inputs

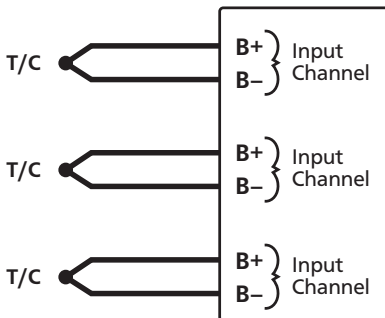

Note 1 All thermocouple inputs are isolated from each other. There is no need to buy expensive isolated thermocouples.

Note 2 For accurate thermocouple measurements (especially at low temperatures) the top cover must always be fitted. Avoid drafts and temperature differences across terminals. Once installation is complete, close the cabinet door and allow the cabinet to reach equilibrium. This may take several hours. Place all thermocouple probes into a calibrated thermal bath at temperature of interest. Any offsets can be zeroed out in the software.

Note 3 All thermocouples are referenced to a combination of four CJC temperature sensors on the main Zen board. This minimizes errors caused by the mounting orientation of the Zen unit, and temperature differences in enclosures. However, for high accuracy applications it is still

recommended to zero errors (see Note 2).

Note 4 All cables must be screened, with screen earthed at one end only.

Note 5 When thermocouple inputs are selected, an upscale resistor is automatically connected to the T/C + input, resulting in an overflow condition for open or broken sensors.

Note 4 Do not run input cables in close vicinity to noisy power supplies, contactors or motor cables. The best practice is to run input cables on a separate earthed cable tray. This will minimise RFI effects, of which magnitude cannot be easily predicted.

6.5 - Digital pulse

Zen RTU/U

Frequency range 0–2500.0Hz

Fast counter range 0–2500.0Hz

Sensors Open collector (NPN, PNP), TTL or Clean Contact

Frequency resolution 0.1Hz

Debounce counter range 0–50Hz max

Counter register output 32 bit

Accuracy $\pm 0.5\%$

The Zen RTU/U's 16 universal input terminals accept digital inputs from NPN, PNP or TTL sensors as well as Clean Contacts. Pulses up to 2.5kHz can be counted (except for the debounced counter, which has a range of 0–50Hz).

A variety of operating modes are software programmable to suit your application.

Software programmable modes include:

- > General counter
- > General debounced counter (ideal for mechanical relay contacts which are subject to bouncing)
- > General frequency
- > Flow count (uses K-factor)
- > Flow rate (uses K-factor)
- > RPM (uses pulses per revolution)

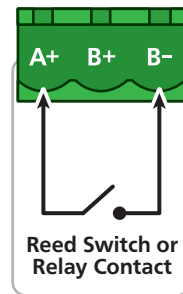
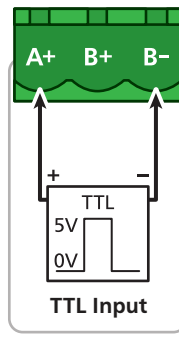
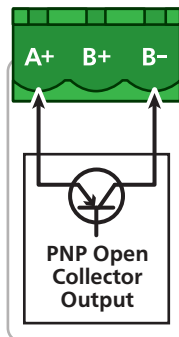
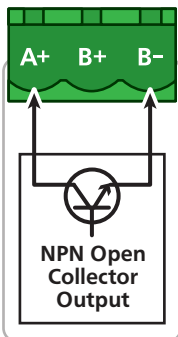

Connection Example for Digital Pulse Inputs

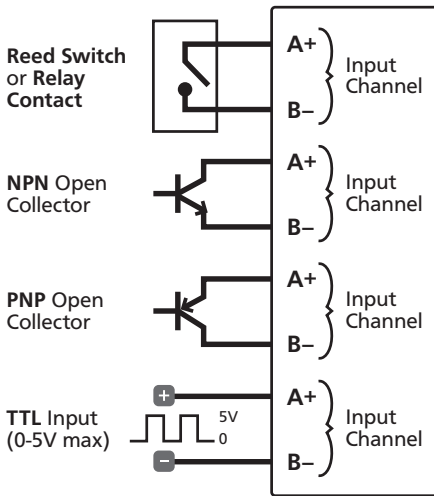

Note 1 All digital inputs are isolated from each other. Inputs from various sources can be connected without fear of crating unwanted and troublesome ground loops.

Note 2 Software selectable functions include: frequency to 2kHz, debounced counter for contact closures to 100Hz maximum, fast counter to 20KHz.

Note 3 All cables must be screened, with screen earthed at one end only.

Note 4 Do not run input cables in close vicinity to noisy power supplies, contactors or motor cables. The best practice is to run input cables on a separate earthed cable tray. This will minimise RFI effects, of which magnitude cannot be easily predicted.

6.6 - Potentiometer input

Zen RTU/U

Potentiometer input 3-wire

Excitation voltage Variable

Potentiometer resistance <2k Ω low pot;
>2k Ω high pot

Field prog zero 0–90% of span

Field prog span 0.1–100%

Linearity and repeatability
< $\pm 0.05\%$ FSO typical

Response time 100msec

Temperature drift <50ppm/ $^{\circ}$ C

A 3 wire potentiometer is typically used to measure position. A low or high potentiometer range can be programmed to your unit using the WorkBench software.

These ranges must be calibrated using the two point calibration method.

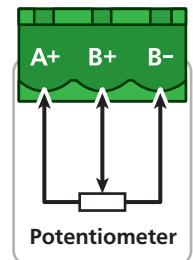

6.7 - AC current sensor

Zen RTU/U

Sensor type Current transformer
ACCS-420, ACCS-420-L and ACCS-010

Header selectable amperage range
ACCS-420/010 = 100/150/200A
ACCS-420-L = 10/20/50A

Output (Representing 0–100% of full scale input range)
ACCS-420(-L) = 4–20mA DC loop powered
ACCS-010 = 0–10V DC

Isolation voltage 2,000V

Power supply

ACCS-420(-L) = Loop powered, 15–36V DC
ACCS-010 = Self powered

Overload (continuous)

ACCS-420/010 = 175/300/400A respectively
ACCS-420-L = 80/120/200A respectively

Accuracy 1% of full scale

Response time 250ms (10–90%)

Frequency 50–60Hz

The Zen RTU/U accepts input from a Define Instruments AC current sensor.

Set the jumper on the top of the current sensor to the desired current range, as shown below.

ACCS Jump Ranges

010/420:	0–100A	0–150A	0–200A
420-L:	0–10A	0–20A	0–50A

High



Mid

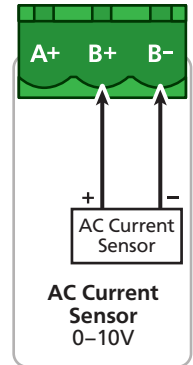
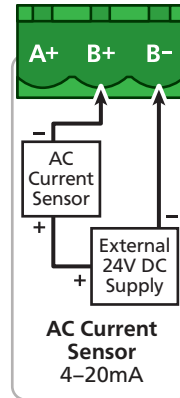

6.8 - Attenuator

Zen RTU/U

Max input voltage 1000V DC

Output impedance 3.8k Ω

Attenuation factor
1000 \pm 0.1%

Attenuator type
Differential resistive

Input impedance 3.8M Ω

Ambient drift 50ppm/ $^{\circ}$ C max

The Zen RTU/U accepts input from a high voltage attenuator (HVA-1000). Wire the attenuator as shown.

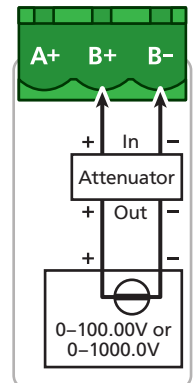

7.1 - Zen registers

Below is a list of the commonly used Zen RTU registers. For a full register list, please see the **Zen Registers** document, available at: defineinstruments.com/zen-registers

Analog inputs 32 bit signed registers

Ch1= 645/646	Ch2= 647/648
Ch3= 649/650	Ch4= 651/652
Ch5= 653/654	Ch6= 655/656
Ch7= 657/658	Ch8= 659/660
Ch9= 661/662	Ch10= 663/664
Ch11= 665/666	Ch12= 667/668
Ch13= 669/670	Ch14= 671/672
Ch15= 673/674	Ch16= 675/676

Counter/frequency inputs 32 bit signed integers

Counter1= 525/526
Counter2= 527/528
Counter3= 529/530
Counter4= 531/532

Analog inputs 32 bit floating point

Ch1= 1193/1194	Ch2= 1195/1196
Ch3= 1197/1198	Ch4= 1199/1200
Ch5= 1201/1202	Ch6= 1203/1204
Ch7= 1205/1206	Ch8= 1207/1208
Ch9= 1209/1210	Ch10= 1211/1212
Ch11= 1213/1214	Ch12= 1215/1216
Ch13= 1217/1218	Ch14= 1219/1220
Ch15= 1221/1222	Ch16= 1223/1224

Totalizers 32 bit signed integers

Total1= 289/290	Total2= 291/292
Total3= 293/294	Total4= 295/296
Total5= 297/298	Total6= 299/300
Total7= 301/302	Total8= 303/304
Total9= 305/306	Total10= 307/308

8

MAINTENANCE

8.1 - Calibration

Your Zen RTU has been fully calibrated at the factory, and can be recalibrated in software using Define WorkBench (see Section 4). Scaling to convert the input signal to a desired display value is also done using WorkBench

If your Zen unit appears to be behaving incorrectly or inaccurately, refer to troubleshooting before attempting to calibrate it. When recalibration is required (generally every 2 years), it should only be performed by qualified technicians using appropriate equipment.

Calibration does not change any user programmed parameters. However, it may affect the accuracy of the input signal values previously stored.

8.2 - Troubleshooting

Issue	Resolution
Input signal is not reading correctly on Zen RTU/U	<i>Check positioning of fail-safe micro switch</i> The fail-safe micro switch should be switched off for all input types except mA. See 6.1 to confirm.
Auto-detecting RS Port is not working	Ensure that any terminal connections marked 'NC' are left open - otherwise the Zen will not be able to auto-detect your serial type.
Beat light stays ON for more than 1 minute	This indicates an error. Please return the Zen RTU to the manufacturer for analysis and repair.
Cannot power up unit	Check the power supply connections and supply range. (The polarity on the power input is irrelevant.)
Ethernet device does not appear on the network when trying to connect in WorkBench	Repower the device after you plug in the ethernet cable to ensure that it appears on the network.

For further assistance, please contact technical support using the contact details listed at the end of this document.

A

APPENDIX A - EMC TEST RESULTS

Statement of compliance

Products in the Define Instruments 'Zen' series comply with EN 61326-1:2006.

Results summary

The results from testing carried out in March 2014 are summarized in the following tables.

Immunity - Enclosure Ports

Phenomenon	Basic Standard	Test Value	Performance Criteria
EM Field	IEC 61000-4-3	10Vm (80MHz to 1GHz) 3V/m (1.4–2.7GHz)	Meets Criterion A
Electrostatic Discharge (ESD)	IEC 61000-4-2	4kV/8kV contact/air	Meets Criterion A (Note 1) Meets NAMUR NE 21 recommendation

Immunity - Signal Ports

Phenomenon	Basic Standard	Test Value	Performance Criteria
Conducted RF	IEC 61000-4-6	3V (150kHz to 80MHz)	Meets Criterion A
Burst	IEC 61000-4-4	1kV (5/50ns, 5kHz) 1kV (5/50ns, 100kHz)	Meets Criterion A (Note 1) Meets NAMUR NE 21 recommendation
Surge	IEC 61000-4-5	1kV L-E	Meets Criterion A (Note 1)

Immunity - AC Power

Phenomenon	Basic Standard	Test Value	Performance Criteria
Conducted RF	IEC 61000-4-6	3V(150Khz to 80Mhz)	Meets Criterion A
Burst	IEC 61000-4-4	2kV (5/50ns, 5kHz) L-N 1kV (5/50ns, 5kHz) L-L	Meets Criterion A Meets Criterion A
Surge	IEC 61000-4-5	2kV L-E 1KV L-L	Meets Criterion A Meets Criterion A (Note 1)
Voltage Dips	IEC 61000-4-11	0% during 1 cycle 40% during 10/12 cycles 70% during 25/30 cycles	Meets Criterion A Meets Criterion A Meets Criterion A
Short Interruptions	IEC 61000-4-11	0% during 250/300 cycles	Meets Criterion A (Note 1)

Performance Criteria

Performance Criterion A

During the test, normal performance within the specification limits.

Performance Criterion B

During testing, temporary degradation, or loss of performance or function which is self-recovering.

Performance Criterion C

During testing, temporary degradation, or loss of function or performance which requires operator intervention or system reset occurs.

*Note 1: EN61326-1 calls for a Criterion B pass; unit exceeds this by meeting Criterion A.



Define Instruments

New Zealand (Head Office)

 10B Vega Place, Rosedale,
Auckland 0632, New Zealand
PO Box 245 Westpark Village,
Auckland 0661, New Zealand

Ph: +64 (9) 835 1550

Fax: +64 (9) 835 1250

 sales@defineinstruments.co.nz

www.defineinstruments.co.nz

United States (Dallas, TX)

Ph: (214) 926 4950

 sales@defineinstruments.com

www.defineinstruments.com

South Africa (Pretoria)

 sales@defineinstruments.co.za

www.defineinstruments.co.za