

YPP7000 Temperature Input Meter Instruction Manual



PROPLUS



- J, K, T, E, R, S, B, N, C Thermocouples
- 100 or 1000 Ω Platinum, 10 Ω Copper, 120 Ω Nickel RTDs
- 1° or 0.1° Resolution
- Averages up to 10 RTD Sensors
- Automatic Cold Junction Compensation
- NEMA 4X, IP65 Front
- Universal 85-265 VAC, or 12/24 VDC Input Power Models
- Large Dual-Line 6-Character Display, 0.60" & 0.46"
- Programmable Displays & Function Keys
- Sunlight Readable Display Models
- 2 or 4 Relays + Isolated 4-20 mA Output Options
- External 4-Relay & Digital I/O Expansion Modules
- USB, RS-232, RS-485 Serial Communication Options
- Modbus[®] RTU Protocol Standard
- Free **PROPLUS** Software for Operation, Monitoring, and Programming

YOKOGAWA ◆

2 Dart Road • Newnan, Georgia 30265
770-253-7000 • 800-888-6400

Fax: 770-251-2088 • www.yokogawa-usa.com

Disclaimer

The information contained in this document is subject to change without notice. Yokogawa Corporation of America makes no representations or warranties with respect to the contents hereof and specifically disclaims any implied warranties of merchantability or fitness for a particular purpose.



CAUTION: Read complete instructions prior to installation and operation of the meter.



WARNING: Risk of electric shock or personal injury.



Warning!

This product is not recommended for life support applications or applications where malfunctioning could result in personal injury or property loss. Anyone using this product for such applications does so at his/her own risk. Yokogawa Corporation of America shall not be held liable for damages resulting from such improper use.

Limited Warranty

Yokogawa Corporation of America warrants this product against defects in material or workmanship for the specified period under "Specifications" from the date of shipment from the factory.

Yokogawa's liability under this limited warranty shall not exceed the purchase value, repair, or replacement of the defective unit.

Registered Trademarks

All trademarks mentioned in this document are the property of their respective owners.

© 2011 Yokogawa Corporation of America. All rights reserved.

www.yokogawa-usa.com

Table of Contents

INTRODUCTION	6
ORDERING INFORMATION	7
SPECIFICATIONS	8
General	8
Temperature Input	9
Relays	10
Isolated 4-20 mA Transmitter Output	11
Modbus [®] RTU Serial Communications	12
YPPA1044 Digital Input & Output Expansion Module	12
COMPLIANCE INFORMATION	13
Safety	13
Electromagnetic Compatibility	13
SAFETY INFORMATION	14
INSTALLATION	15
Unpacking	15
Panel Mounting Instructions	15
Configuration for 12 or 24 VDC Power Option	16
Connections	17
Connectors Labeling	18
Power Connections	18
Signal Connections	19
Connections for Averaging RTD Sensors	21
Modbus RTU Serial Communications	22
Relay Connections	22
Switching Inductive Loads	23
4-20 mA Output Connections	24
Analog Output Transmitter Power Supply	24
External Relays & Digital I/O Connections	25
Interlock Relay Feature	26
SETUP AND PROGRAMMING	27
Front Panel Buttons and Status LED Indicators	28
Display Functions & Messages	29
Main Menu	32
Setting Numeric Values	33
Reset Menu (rESEt)	33
Control Menu (ContRL)	33
Setting Up the Meter (SEtUP)	34

Setting the Input Signal (<i>inPut</i>) -----	36
Selecting the Temperature Scale (<i>F or C</i>) -----	36
Setting the Decimal Point (<i>dEc Pt</i>) -----	36
Setting the Display Parameter & Intensity (<i>dSPLRy</i>) -----	36
Display Setup Menu -----	37
Character Set for Engineering Units Display (<i>d UN it</i>) -----	38
Setting the Relay Operation (<i>rELRY</i>) -----	39
Setting the Relay Action -----	41
Programming Set and Reset Points -----	42
Setting Fail-Safe Operation -----	42
Programming Time Delay -----	42
Relay Action for Loss of Input (Input Break) -----	42
PROPLUS Software -----	43
Relay and Alarm Operation Diagrams -----	44
High Alarm Operation (Set > Reset) -----	44
Low Alarm Operation (Set < Reset) -----	45
High Alarm with Fail-Safe Operation (Set > Reset) -----	46
Low Alarm with Fail-Safe Operation (Set < Reset) -----	47
Relay Alternation Control Operation -----	48
Relay Sampling Operation -----	49
Signal Loss or Input Break Relay Operation -----	50
Time Delay Operation -----	51
Relay Operation Details -----	52
Overview -----	52
Relays Auto Initialization -----	52
Fail-Safe Operation -----	52
Front Panel LEDs -----	53
Latching and Non-Latching Relay Operation -----	53
Non-Latching Relay (<i>RutO</i>) -----	54
Non-Latching Relay (<i>R-nRn</i>) -----	54
Latching Relay (<i>LRcH</i>) -----	54
Latching Relay (<i>Lt-CLr</i>) -----	55
Acknowledging Relays -----	55
Setting Up the Interlock Relay (Force On) Feature -----	56
Scaling the 4-20 mA Analog Output (<i>Rout</i>) -----	57
Setting Up the Password (<i>PR55</i>) -----	58
Protecting or Locking the Meter -----	58
Making Changes to a Password Protected Meter -----	59
Disabling Password Protection -----	59
Advanced Features Menu -----	60
Advanced Features Menu & Display Messages -----	61
Offset Adjust (<i>RdJut</i>) -----	62

Model YPP7000 Temperature Input Meter	Instruction Manual
Recalibration of the Meter (t $\bar{r}L$)-----	63
Noise Filter (F $\bar{r}L\bar{r}$)-----	65
Noise Filter Bypass (b $\bar{y}P\bar{r}55$)-----	65
Modbus RTU Serial Communications (5Er $\bar{r}L$)-----	66
Select Menu (5E $\bar{r}c\bar{t}$)-----	67
Analog Output Programming (R $\bar{o}u\bar{t}P\bar{r}$)-----	68
Programmable Function Keys User Menu (u5Er)-----	69
Internal Temperature Calibration ($\bar{r}L$)-----	70
Meter Copy Function (E $\bar{o}P\bar{y}$)-----	73
METER OPERATION -----	75
Front Panel Buttons Operation -----	75
Function Keys Operation -----	75
Maximum/Minimum Readings -----	76
TROUBLESHOOTING -----	77
Diagnosics Menu (d $\bar{r}L$) -----	77
Determining Software Version-----	77
Reset Meter to Factory Defaults -----	78
Factory Defaults & User Settings-----	79
Troubleshooting Tips -----	82
DIMENSIONS -----	83

Table of Figures

Figure 1. 1/8 DIN Panel Cutout Dimensions	15
Figure 2. Panel Mounting Details	16
Figure 3. Jumper Configuration for 12/24 VDC Power	16
Figure 4. Connector Labeling for Fully Loaded YPP7000	18
Figure 5. Power Connections	18
Figure 6. Thermocouple Input Connections	19
Figure 7. Three-Wire RTD Input Connections	20
Figure 8. Two-Wire RTD Input Connections	20
Figure 9. Four-Wire RTD Input Connections	21
Figure 10. Average Temperature RTD Input Connections	21
Figure 11. Relay Connections	22
Figure 12. AC and DC Loads Protection.....	23
Figure 13. Low Voltage DC Loads Protection	23
Figure 14. 4-20 mA Output Connections	24
Figure 15. Expansion Modules & DIN Rail Mounting Kit.....	25
Figure 16. External Relays Module Connections.....	25
Figure 17. Digital I/O Module Connections.....	26
Figure 18. Interlock Connections	26
Figure 19. Acknowledge Relays w/Function Key or Digital Input ..	55
Figure 20. Meter Copy Connection	73
Figure 21. Meter Dimensions - Side View	83
Figure 22. Meter Dimensions - Top View.....	83
Figure 23: 1/8 DIN Panel Cutout Template	86

INTRODUCTION

The **PROPLUS** YPP7000 meter boasts specifications and functionality that clearly makes it one of the most advanced temperature meters available. Its dual-line 6-character display, function keys, and optional expansion modules are only a few of the features you will find on the **PROPLUS**.

A fully loaded YPP7000 meter has the following: four SPDT relays, 4-20 mA output, and one 24 VDC power supply to power the 4-20 mA output. The YPP7000 capabilities may be enhanced by adding the following external expansion modules: four SPST relays (creating an eight-relay temperature meter), two digital I/O modules with four inputs and four outputs each, and USB, RS-232 or RS-485 communication adapters.

The eight relays can be used for alarm indication or temperature control applications. The 4-20 mA isolated output, Modbus RTU serial communications, and digital I/O options make the YPP7000 an excellent addition to any system.

ORDERING INFORMATION**Standard Models**

85-265 VAC Model	12/24 VDC Model	Options Installed
YPP7000-6R0	YPP7000-7R0	No options
YPP7000-6R2	YPP7000-7R2	2 relays
YPP7000-6R3	YPP7000-7R3	4-20 mA output
YPP7000-6R4	YPP7000-7R4	4 relays
YPP7000-6R5	YPP7000-7R5	2 relays & 4-20 mA output
YPP7000-6R7	YPP7000-7R7	4 relays & 4-20 mA output

SunBright Display Models

85-265 VAC Model	12/24 VDC Model	Options Installed
YPP7000-6H0	YPP7000-7H0	No options
YPP7000-6H2	YPP7000-7H2	2 relays
YPP7000-6H3	YPP7000-7H3	4-20 mA output
YPP7000-6H4	YPP7000-7H4	4 relays
YPP7000-6H5	YPP7000-7H5	2 relays & 4-20 mA output
YPP7000-6H7	YPP7000-7H7	4 relays & 4-20 mA output

Accessories

Model	Description
YPPA1002	DIN rail mounting kit for two expansion modules
YPPA1004	4 SPST (Form A) relays
YPPA1044	4 digital inputs & 4 digital outputs (2 may be connected)
YPPA1200	Meter copy cable
YPPA1232	RS-232 serial adapter
YPPA1485	RS-485 serial adapter
YPPA7485-I	RS-232 to RS-422/485 isolated converter
YPPA7485-N	RS-232 to RS-422/485 non-isolated converter
YPPA8008	USB serial adapter
YPPA8232-N	USB to RS-232 non-isolated converter
YPPA8485-I	USB to RS-422/485 isolated converter
YPPA8485-N	USB to RS-422/485 non-isolated converter
YPPX6901	Suppressor (snubber): 0.01 μ F/470 Ω , 250 VAC

Enclosures

Model	Description
YPPA2811	1 Meter Plastic NEMA 4X Enclosure
YPPA2812	2 Meter Plastic NEMA 4X Enclosure

SPECIFICATIONS

Except where noted all specifications apply to operation at +25°C.

General

DISPLAY	Main display: 0.60" (15 mm) high red LEDs; second display: 0.46" (12 mm) high red LEDs. Both displays have six characters with leading zero blanking. Temperature value is four or five-digit F/C, based on configuration.
RESOLUTION	1° or 0.1° for all thermocouples and RTD inputs
DISPLAY INTENSITY	Eight user selectable intensity levels
DISPLAY UPDATE RATE	5/second (200 ms)
OVERRANGE	Display flashes 99999
UNDERRANGE	Display flashes -9999
PROGRAMMING METHODS	Four front panel buttons, digital inputs, PC and PROPLUS software, Modbus registers, or cloning using Copy function.
NOISE FILTER	Programmable from 2 to 199 (0 will disable filter)
FILTER BYPASS	Programmable from 0.1 to 99.9% of calibrated span
RECALIBRATION	All ranges are calibrated at the factory. Recalibration is recommended at least every 12 months.
MAX/MIN DISPLAY	Max/min readings reached by the process are stored until reset by the user or until power to the meter is turned off.
PASSWORD	Three programmable passwords restrict modification of programmed settings. Pass 1: Allows use of function keys and digital inputs Pass 2: Allows use of function keys, digital inputs and editing set/reset points Pass 3: Restricts all programming, function keys, and digital inputs.
NON-VOLATILE MEMORY	All programmed settings are stored in non-volatile memory for a minimum of ten years if power is lost.
POWER OPTIONS	85-265 VAC 50/60 Hz, 90-265 VDC, 20 W max or jumper selectable 12/24 VDC \pm 10%, 15 W max
FUSE	Required external fuse: UL Recognized, 5 A max, slow blow; up to 6 meters may share one 5 A fuse
NORMAL MODE REJECTION	Greater than 60 dB at 50/60 Hz
ISOLATION	4 kV input/output-to-power line 500 V input-to-output

OVERVOLTAGE CATEGORY	Installation Overvoltage Category II: Local level with smaller transient overvoltages than Installation Overvoltage Category III.
ENVIRONMENTAL	Operating temperature range: -20 to 65°C Storage temperature range: -40 to 85°C Relative humidity: 0 to 90% non-condensing
CONNECTIONS	Removable screw terminal blocks accept 12 to 22 AWG wire, RJ45 for external relays, digital I/O, and serial communication adapters.
ENCLOSURE	1/8 DIN, high impact plastic, UL 94V-0, color: black
MOUNTING	1/8 DIN panel cutout required: 3.622" x 1.772" (92 mm x 45 mm) Two panel mounting bracket assemblies are provided.
TIGHTENING TORQUE	Screw terminal connectors: 5 lb-in (0.56 Nm)
OVERALL DIMENSIONS	4.68" x 2.45" x 5.64" (119 mm x 62 mm x 143 mm) (W x H x D)
WEIGHT	9.5 oz (269 g)
WARRANTY	3 years parts & labor

Temperature Input

INPUTS	Thermocouple: J, K, T, E, R, S, B, N, C; RTD: 100 Ω platinum (0.00385 & 0.00392 coefficients), 10 Ω copper, 120 Ω nickel, 1000 Ω platinum (0.00385 & 0.00392 coefficients)
COLD JUNCTION REFERENCE	Automatic, fixed, no user calibration needed
TEMPERATURE DRIFT	±2°C maximum from 0 to 65°C ambient temperature ±4°C maximum from -20 to 0°C ambient temperature
OFFSET ADJUSTMENT	User programmable offset adjust ±50.0 degrees. This parameter allows the user to apply an offset value to the temperature being displayed.
INPUT IMPEDANCE	Greater than 100 kΩ
SENSOR BREAK DETECTION	Open TC or RTD sensor indicated by display flashing oPEn , relays can be programmed to go "On", "Off", or to "Ignore" (Note: Ignore is detected as an upscale condition). Analog output goes to the programmed sensor break value.
RTD AVERAGING	Up to 10 RTDs connected in parallel can be averaged.

ACCURACY & RANGES

Type	Range (°F)	Accuracy	Range (°C)	Accuracy
J	-200 to 2000	±1.8°F	-129 to 1093	±1°C
K	-200 to 2400	±1.8°F	-129 to 1316	±1°C
T	-200 to 752	±1.8°F	-129 to 400	±1°C
E	-200 to 1800	±1.8°F	-129 to 982	±1°C
R	-50 to 3000	±3.6°F	-46 to 1649	±2°C
S	-50 to 3000	±3.6°F	-46 to 1649	±2°C
B	752 to 3300	±3.6°F	400 to 1816	±2°C
N	-100 to 2300	±3.6°F	-73 to 1260	±2°C
C	32 to 4100	±3.6°F	0 to 2260	±2°C
10Ω	-328 to 500	±0.2°F	-200 to 260	±0.1°C
100Ω	-328 to 1562	±0.7°F	-200 to 850	±0.4°C
120Ω	-110 to 500	±0.2°F	-79 to 260	±0.1°C
1000Ω	-328 to 900	±0.7°F	-200 to 482	±0.4°C

Relays

RATING	2 or 4 SPDT (Form C) internal and/or 4 SPST (Form A) external; rated 3 A @ 30 VDC and 125/250 VAC resistive load; 1/14 HP (≈ 50 W) @ 125/250 VAC for inductive loads
NOISE SUPPRESSION	Noise suppression is recommended for each relay contact switching inductive loads; see page 23 for details.
DEADBAND	0-100% of span, user programmable
HIGH OR LOW ALARM	User may program any alarm for high or low trip point. Unused alarm LEDs and relays may be disabled (turn off).
RELAY OPERATION	Automatic (non-latching) Latching (requires manual acknowledge) Sampling (based on time) Relay alternation control (2 to 8 relays) Off (disable unused relays and enable Interlock feature) Manual on/off control mode

RELAY RESET	User selectable via front panel buttons or digital inputs <ol style="list-style-type: none"> 1. Automatic reset only (non-latching), when the input passes the reset point. 2. Automatic + manual reset at any time (non-latching) 3. Manual reset only, at any time (latching) 4. Manual reset only after alarm condition has cleared (L) <i>Note: Front panel button or digital input may be assigned to acknowledge relays programmed for manual reset.</i>
TIME DELAY	0 to 999.9 seconds, on & off relay time delays Programmable and independent for each relay
FAIL-SAFE OPERATION	Programmable and independent for each relay. <i>Note: Relay coil is energized in non-alarm condition. In case of power failure, relay will go to alarm state.</i>
AUTO INITIALIZATION	When power is applied to the meter, relays will reflect the state of the input to the meter.

Isolated 4-20 mA Transmitter Output

OUTPUT SOURCE	PV (temperature), max, min, set points 1-8, Modbus PV input, or manual control mode		
SCALING RANGE	1.000 to 23.000 mA for any display range		
CALIBRATION	Factory calibrated 0.0 to 2000.0 = 4-20 mA output		
ANALOG OUT PROGRAMMING	23.000 mA maximum for all parameters: Overrange, underrange, max, min, and break		
ACCURACY	$\pm 0.1\%$ of span ± 0.004 mA		
TEMPERATURE DRIFT	0.4 $\mu\text{A}/^\circ\text{C}$ max from 0 to 65 $^\circ\text{C}$ ambient, 0.8 $\mu\text{A}/^\circ\text{C}$ max from -20 to 0 $^\circ\text{C}$ ambient <i>Note: Analog output drift is separate from input drift.</i>		
ISOLATED TRANSMITTER POWER SUPPLY	Terminals I+ & R: 24 VDC $\pm 5\%$ @ 40 mA maximum; may be used to power the 4-20 mA output or other devices. Refer to Figure 4 on page 18 and Figure 14 on page 24.		
EXTERNAL LOOP POWER SUPPLY	35 VDC maximum		
OUTPUT LOOP RESISTANCE	Power supply	Minimum	Maximum
	24 VDC	10 Ω	700 Ω
	35 VDC (external)	100 Ω	1200 Ω

Modbus[®] RTU Serial Communications

SLAVE ID	1 – 247 (Meter address)
BAUD RATE	300 – 19,200 bps
TRANSMIT TIME DELAY	Programmable between 0 and 199 ms
DATA	8 bit (1 start bit, 1 or 2 stop bits)
PARITY	Even, Odd, or None with 1 or 2 stop bits
BYTE-TO-BYTE TIMEOUT	0.01 to 2.54 sec
TURN AROUND DELAY	Less than 2 ms (fixed)

*Note: Refer to the **PROPLUS** Modbus Register Tables located at www.yokogawa-usa.com for details.*

YPPA1044 Digital Input & Output Expansion Module

CHANNELS	4 digital inputs & 4 digital outputs per module
SYSTEM	Up to 2 modules for a total of 8 inputs & 8 outputs
DIGITAL INPUT LOGIC HIGH	3 to 5 VDC
DIGITAL INPUT LOGIC LOW	0 to 1.25 VDC
DIGITAL OUTPUT LOGIC HIGH	3.1 to 3.3 VDC
DIGITAL OUTPUT LOGIC LOW	0 to 0.4 VDC
SOURCE CURRENT	10 mA maximum output current
SINK CURRENT	1.5 mA minimum input current
+5 V TERMINAL	To be used as pull-up for digital inputs only. Connect normally open contacts across +5 V & DI 1-4

COMPLIANCE INFORMATION**Safety**

UL & c-UL LISTED	USA & Canada UL 508 Industrial Control Equipment
UL FILE NUMBER	E348677
FRONT PANEL	UL Type 4X, NEMA 4X, IP65; panel gasket provided
LOW VOLTAGE DIRECTIVE	EN 61010-1:2001 Safety requirements for measurement, control, and laboratory use

Electromagnetic Compatibility

EMISSIONS	EN 55022:2006/A1:2007 Class A ITE emissions requirements
Radiated Emissions	Class A
AC Mains Conducted Emissions	Class A
IMMUNITY	EN 61326-1:2006 Measurement, control, and laboratory equipment EN 61000-6-2:2005 EMC heavy industrial generic immunity standard
RFI - Amplitude Modulated	80 -1000 MHz 10 V/m 80% AM (1 kHz) 1.4 - 2.0 GHz 3 V/m 80% AM (1 kHz) 2.0 - 2.7 GHz 1 V/m 80% AM (1 kHz)
Electrical Fast Transients	±2kV AC mains, ±1kV other
Electrostatic Discharge	±4kV contact, ±8kV air
RFI - Conducted	10V, 0.15-80 MHz, 1kHz 80% AM
AC Surge	±2kV Common, ±1kV Differential
Surge	1KV (CM)
Power-Frequency Magnetic Field	3 A/m 70%V for 0.5 period
Voltage Dips	40%V for 5 & 50 periods 70%V for 25 periods
Voltage Interruptions	<5%V for 250 periods

Note:

Testing was conducted on YPP7000 meters installed through the covers of grounded metal enclosures with cable shields grounded at the point of entry representing installations designed to optimize EMC performance.

Declaration of Conformity available at www.yokogawa-usa.com

SAFETY INFORMATION

CAUTION: Read complete instructions prior to installation and operation of the meter.



WARNING: Risk of electric shock or personal injury.



WARNING!

Hazardous voltages exist within enclosure. Installation and service should be performed only by trained service personnel.

INSTALLATION

There is no need to remove the meter from its case to complete the installation, wiring, and setup.

Instructions are provided for setting up a 12/24 VDC powered meter to operate from 12 VDC power, see page 16.

Unpacking

Remove the meter from box. Inspect the packaging and contents for damage. Report damages, if any, to the carrier.

If any part is missing or the meter malfunctions, please contact your supplier or the factory for assistance.

Panel Mounting Instructions

- Prepare a standard 1/8 DIN panel cutout – 3.622" x 1.772" (92 mm x 45 mm). Refer to Figure 1 below, for more details.
- Clearance: allow at least 6.0" (152 mm) behind the panel for wiring.
- Panel thickness: 0.04" - 0.25" (1.0 mm - 6.4 mm).
Recommended minimum panel thickness to maintain Type 4X rating: 0.06" (1.5 mm) steel panel, 0.16" (4.1 mm) plastic panel.
- Remove the two mounting brackets provided with the meter (back-off the two screws so that there is 1/4" (6.4 mm) or less through the bracket. Slide the bracket toward the front of the case and remove).
- Insert meter into the panel cutout.
- Install mounting brackets and tighten the screws against the panel. To achieve a proper seal, tighten the mounting bracket screws evenly until meter is snug to the panel along its short side. DO NOT OVER TIGHTEN, as the rear of the panel may be damaged.

Note: See Figure 23 on page 86 for 1/8 DIN Panel Cutout Template

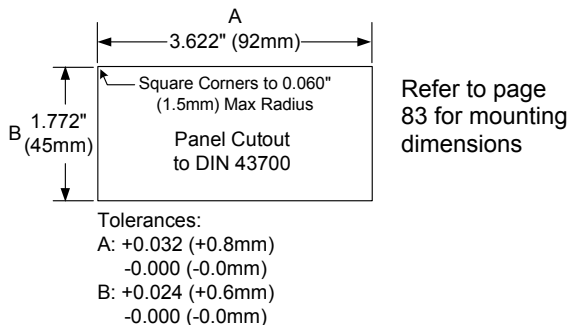

Figure 1. 1/8 DIN Panel Cutout Dimensions

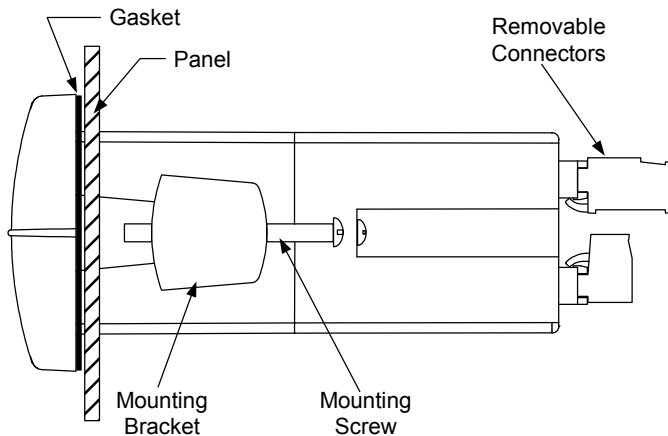

Figure 2. Panel Mounting Details

Configuration for 12 or 24 VDC Power Option



Do not exceed voltage rating of the selected configuration.

Meters equipped with the 12/24 VDC power option are shipped from the factory ready to operate from 24 VDC.

To configure the meter for 12 VDC power:

1. Remove all the connectors.
2. Unscrew the back cover.
3. Slide the back cover about 1 inch.
4. Configure the J9 jumper, located behind the power connector, for 12 V as shown below.

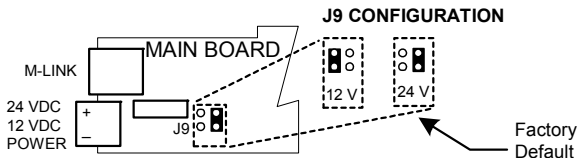

Figure 3. Jumper Configuration for 12/24 VDC Power

Connections

All connections are made to removable screw terminal connectors located at the rear of the meter.



Use copper wire with 60°C or 60/75°C insulation for all line voltage connections. Observe all safety regulations. Electrical wiring should be performed in accordance with all applicable national, state, and local codes to prevent damage to the meter and ensure personnel safety.

Connectors Labeling

The connectors' label, affixed to the meter, shows the location of all connectors available with requested configuration.



Warning!

Do not connect any equipment other than Yokogawa's expansion modules, cables, or meters to the RJ45 M-LINK connector. Otherwise damage will occur to the equipment and the meter.

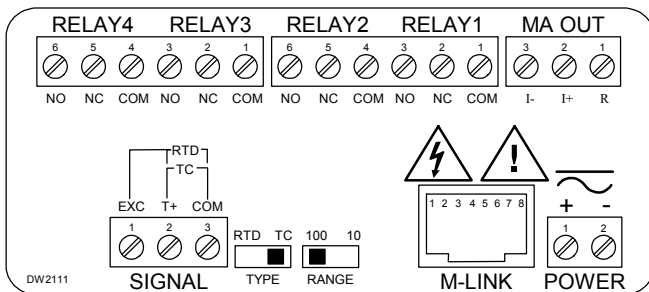
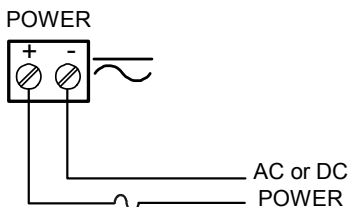

Figure 4. Connector Labeling for Fully Loaded YPP7000

Power Connections

Power connections are made to a two-terminal connector labeled POWER on Figure 4. The meter will operate regardless of DC polarity connection. The + and - symbols are only a suggested wiring convention.



Required External Fuse:
5 A max, 250 V Slow Blow

Figure 5. Power Connections

Signal Connections

Signal connections are made to a three-terminal connector labeled SIGNAL on Figure 4.

Thermocouple and RTD Connections

The following figures show examples for thermocouple and RTD connections.

The TYPE selector switch must be set to the proper position for the meter to accept the selected RTD or TC input.

The RANGE selector switch is used to select 100-ohm platinum or 10-ohm copper RTD. The 1000-ohm platinum RTD input uses the same setting as the 100-ohm RTD.

The input type is selected using the *Setup* menu.

The selected thermocouple input must correspond to the thermocouple sensor and wire type used.

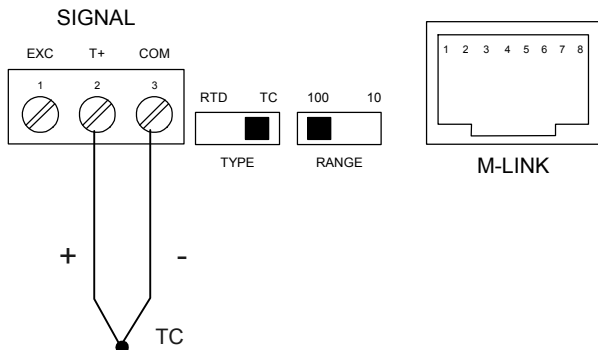

Figure 6. Thermocouple Input Connections

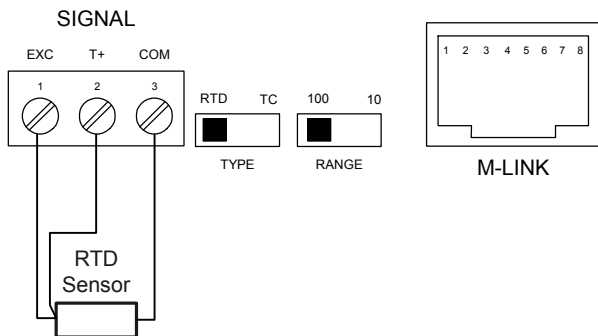

Figure 7. Three-Wire RTD Input Connections

The meter accepts two, three, or four-wire RTDs. The three-wire RTD connection has built-in lead wire compensation.

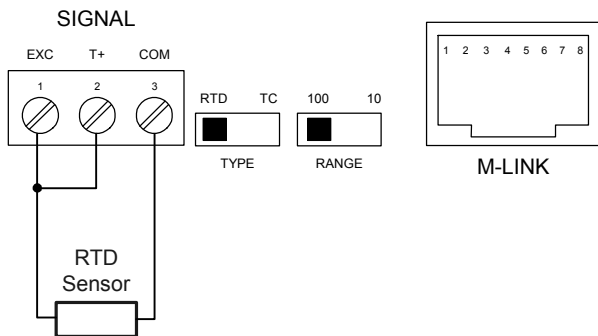

Figure 8. Two-Wire RTD Input Connections

Lead wire compensation for two-wire RTDs can be applied using the *Adjust* menu. See the Advanced Features Menu on page 60.

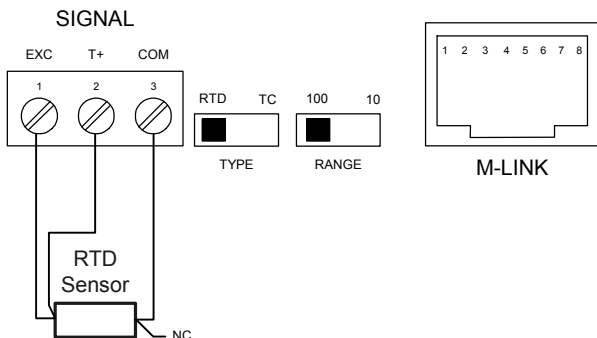

Figure 9. Four-Wire RTD Input Connections

The four-wire RTD connection is similar to the three-wire. One of the leads of a four-wire RTD is not connected, and may be clipped off.

The three-wire connection provides sufficient lead wire compensation to obtain accurate readings even with long leads.

Connections for Averaging RTD Sensors

To obtain the average temperature from 2 to 10 RTD sensors, connect all the sensors in parallel and select the number of sensors in the *RTD Total (rtdtot)* menu. See the Advanced Features Menu on page 60.

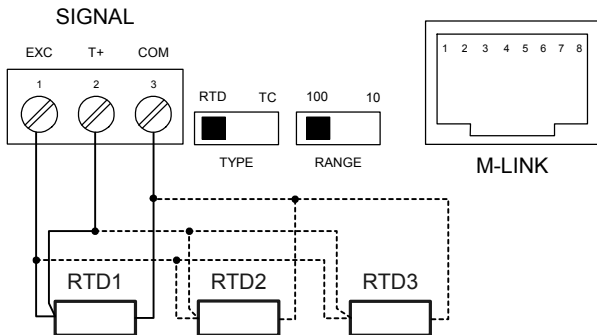

Figure 10. Average Temperature RTD Input Connections

Modbus RTU Serial Communications

Serial communications connection is made to an RJ45 connector labeled M-LINK on Figure 4. For interfacing to the **PROPLUS** use the YPPA1232 for RS-232, the YPPA1485 for RS-485, or the YPPA8008 for USB. The same port is used for interfacing with all expansion modules (*i.e.* external relays, digital I/O).

Use the YPPA1200 meter copy cable for meter-to-meter interfacing for cloning purposes (*i.e.* copying settings from one meter to other meters).

Relay Connections

Relay connections are made to two six-terminal connectors labeled RELAY1 – RELAY4 on Figure 4. Each relay's C terminal is common only to the normally open (NO) and normally closed (NC) contacts of the corresponding relay. The relays' C terminals should not be confused with the COM (common) terminal of the INPUT SIGNAL connector.

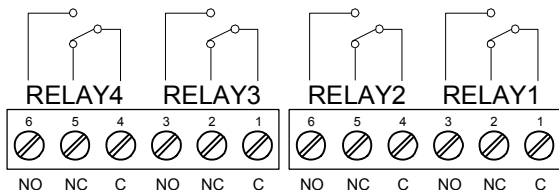

Figure 11. Relay Connections

Switching Inductive Loads

The use of suppressors (snubbers) is strongly recommended when switching inductive loads to prevent disrupting the microprocessor's operation. The suppressors also prolong the life of the relay contacts. Suppression can be obtained with resistor-capacitor (RC) networks assembled by the user or purchased as complete assemblies. Refer to the following circuits for RC network assembly and installation:

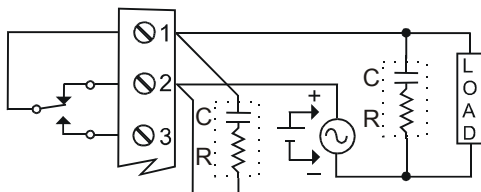

Figure 12. AC and DC Loads Protection

Choose R and C as follows:

R: 0.5 to 1 Ω for each volt across the contacts

C: 0.5 to 1 μF for each amp through closed contacts

Notes:

1. Use capacitors rated for 250 VAC.
2. RC networks may affect load release time of solenoid loads. Check to confirm proper operation.
3. Install the RC network at the meter's relay screw terminals. An RC network may also be installed across the load. Experiment for best results.

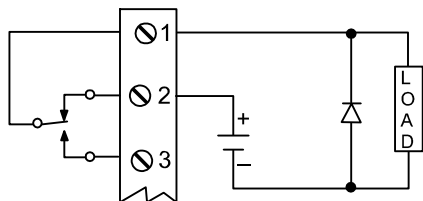

Use a diode with a reverse breakdown voltage two to three times the circuit voltage and forward current at least as large as the load current.

Figure 13. Low Voltage DC Loads Protection

Note: Relays are de-rated to 1/14th HP (50 watts) with an inductive load.

4-20 mA Output Connections

Connections for the 4-20 mA transmitter output are made to the connector terminals labeled MA OUT. The 4-20 mA output may be powered internally or from an external power supply.

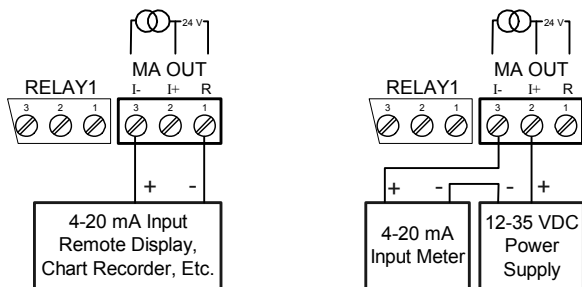

Figure 14. 4-20 mA Output Connections

Analog Output Transmitter Power Supply

The internal 24 VDC power supply powering the analog output may be used to power other devices, if the analog output is not used. The I+ terminal is the +24 V and the R terminal is the return. This power supply is capable of sourcing up to 40 mA.

External Relays & Digital I/O Connections

The relay and the digital I/O expansion modules YPPA1004 & YPPA1044 are connected to the meter using a CAT5 cable provided with each module. The two RJ45 connectors on the expansion modules are identical and interchangeable; they are used to connect additional modules to the system.

Note: The jumper located between the RJ45 connectors of the YPPA1044 must be removed on the second digital I/O module in order for the system to recognize it as module #2.



Warning!

Do not connect or disconnect the expansion modules with the power on!

More detailed instructions are provided with each optional expansion module.

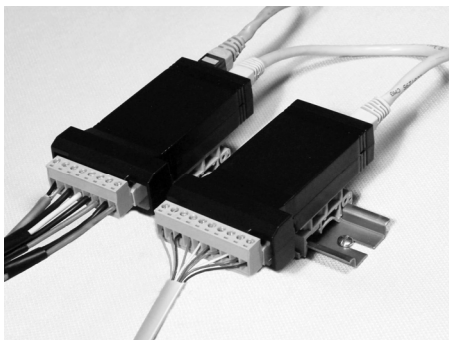

Figure 15. Expansion Modules & DIN Rail Mounting Kit

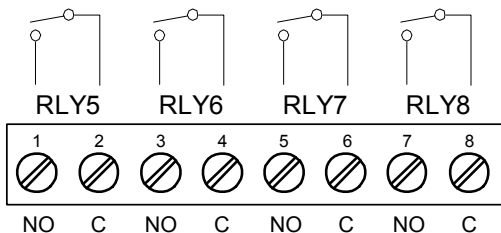

Figure 16. External Relays Module Connections

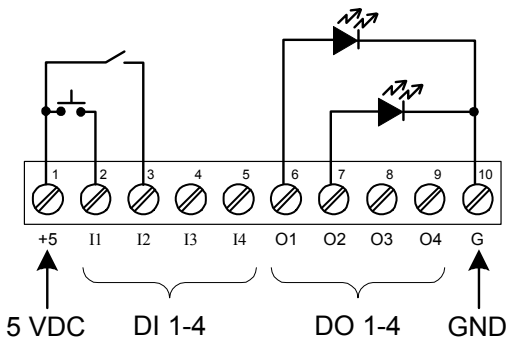

Figure 17. Digital I/O Module Connections

Interlock Relay Feature

As the name implies, the interlock relay feature reassigns one, or more, alarm/control relays for use as interlock relay(s). Interlock contact(s) are wired to digital input(s) and trigger the interlock relay. This feature is enabled by configuring the relay, and relative digital input(s) (see page 56). In one example, dry interlock contacts are connected in series to one digital input which will be used to force on (energize) the assigned interlock power relay when all interlock contacts are closed (safe). The interlock relay front panel LED flashes when locked out. The interlock relay would be wired in-series with the load (N/O contact). See below.

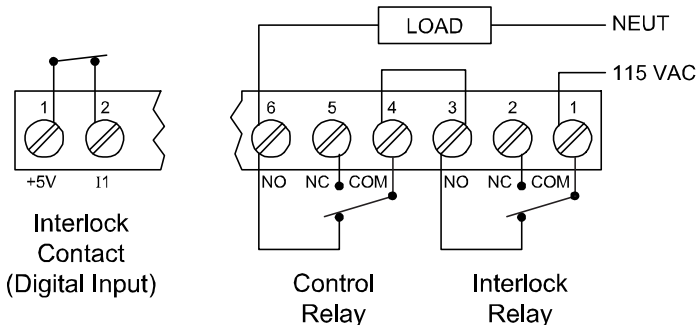

Figure 18. Interlock Connections

SETUP AND PROGRAMMING

The meter is factory calibrated prior to shipment to read temperature in degrees Fahrenheit. The calibration equipment is certified to NIST standards.

Overview

There are two switches, located at the back of the meter, to set the input selection for TC or RTD and for 100-ohm platinum or 10-ohm copper. The 1000-ohm RTD input uses the same setting as the 100-ohm. Setup and programming is done through the front panel buttons. After power and input signal connections have been completed and verified, apply power to the meter.

Front Panel Buttons and Status LED Indicators



Button Symbol	Description
	Menu
	Right arrow/F1
	Up arrow/F2
	Enter/F3
<p><i>Note:</i> Alarms 5-8 are enabled when relay expansion module is installed.</p>	

LED	Status
1-8	Alarm 1-8 indicator
1-8-M	Flashing: Relay in manual control mode
M	Manual control relays &/or analog output
1-4	Flashing: Relay interlock switch open
<p><i>Note:</i> LEDs for relays in manual mode flash with the "M" LED every 10 seconds.</p>	

- Press the Menu button to enter or exit the Programming Mode at any time.
- Press the Right arrow button to move to the next digit during digit or decimal point programming.
- Press or hold the Up arrow button to scroll through the menus, decimal point or to increment the value of a digit.
- Press the Enter button to access a menu or to accept a setting.
- Press and hold the Menu button for three seconds to access the advanced features of the meter.

Display Functions & Messages

The meter displays various functions and messages during setup, programming, and operation. The following table shows the main menu functions and messages in the order they appear in the menu.

Display	Parameter	Action/Setting Description
rESEt	<i>Reset</i>	Press Enter to access the <i>Reset</i> menu
rSt Hi	<i>Reset high</i>	Press Enter to reset max display
rSt Lo	<i>Reset low</i>	Press Enter to reset min display
rSt HL	<i>Reset high & low</i>	Press Enter to reset max & min displays
Control	<i>Control</i>	Enter <i>Control</i> menu
Auto	<i>Automatic</i>	Press Enter to set meter for automatic operation
on An	<i>Manual</i>	Press Enter to manually control relays or analog output operation
SEtUP	<i>Setup</i>	Enter <i>Setup</i> menu
inPut	<i>Input</i>	Enter <i>Input</i> selection menu
tC	<i>TC</i>	Set meter for thermocouple input J, K, T, E, R, S, B, N, C
rtd	<i>RTD</i>	Set meter for RTD input 100Pt, 1000Pt, 10Cu, 120Ni
A385	<i>A385</i>	Set meter for 0.00385 curve
A392	<i>A392</i>	Set meter for 0.00392 curve
F or C	<i>F or C</i>	Press Enter to select degrees F or C
dEc Pt	<i>Decimal point</i>	Set decimal point dddd, dddd.d, dddd°F, dddd.dF
dSPLY	<i>Display</i>	Enter the <i>Display</i> menu
b iD	<i>Big display</i>	Press Enter to assign the Main display parameter (default: PV - temperature)
L iLE	<i>Little display</i>	Press Enter to assign the small display parameter (default: engineering units)

Display	Parameter	Action/Setting Description
d- IntY	Display intensity	Set display intensity level from 1 to 8
rELRY	Relay	Enter the Relay menu
rLY 1	Relay 1	Relay 1 setup
Act 1	Action 1	Set relay 1 action
Auto	Automatic	Set relay for automatic reset
Auto-man	Auto-manual	Set relay for automatic & manual reset any time
LATCH	Latching	Set relay for latching operation
Lt-Clr	Latching-cleared	Set relay for latching operation with manual reset only after alarm condition has cleared
ALtern	Alternate	Set relay for alternation control
SAMPL	Sampling	Set relay for sampling operation
OFF	Off	Disable relay and front panel status LED (Select Off to enable Interlock feature)
Set 1	Set 1	Program set point 1
rSet 1	Reset 1	Program reset point 1
rLY 2	Relay 2	Relays 2-8 setup <i>Note: Relays 5-8 are shown only if expansion relay module is installed</i>
FRILSF	Fail-safe	Enter Fail-safe menu
FLS 1	Fail-safe 1	Set relay 1 fail-safe operation
on	On	Enable fail-safe operation
FLS 2	Fail-safe 2	Set relays 2-8 fail-safe operation
dELRY	Delay	Enter relay Time Delay menu
dLY 1	Delay 1	Enter relay 1 time delay setup
On 1	On 1	Set relay 1 On time delay

Display	Parameter	Action/Setting Description
OFF 1	Off 1	Set relay 1 Off time delay
dLY 2	Delay 2	Enter relays 2-8 time delay setup
brERH	Break	Set relay condition if input break detected
ignore	Ignore	Ignore input break condition (Processed as an upscale condition)
On	On	Relay goes to alarm condition when input break is detected
OFF	Off	Relay goes to non-alarm condition when input break is detected
Rout	Analog output	Enter the <i>Analog output</i> scaling menu
d 15 1	Display 1	Program display 1 value
Out 1	Output 1	Program output 1 value (e.g. 4.000 mA)
d 15 2	Display 2	Program display 2 value
Out 2	Output 2	Program output 2 value (e.g. 20.000 mA)
PR55	Password	Enter the <i>Password</i> menu
PR55 1	Password 1	Set or enter Password 1
PR55 2	Password 2	Set or enter Password 2
PR55 3	Password 3	Set or enter Password 3
unLoc	Unlocked	Program password to lock meter
Locd	Locked	Enter password to unlock meter
99999 -9999	Flashing display	Overrange condition Underrange condition
OPEN	Open	Open sensor indication

Main Menu

The main menu consists of the most commonly used functions: *Reset*, *Control*, *Setup*, and *Password*.

- Press Menu button to enter Programming Mode then press the Up arrow button to scroll main menu.

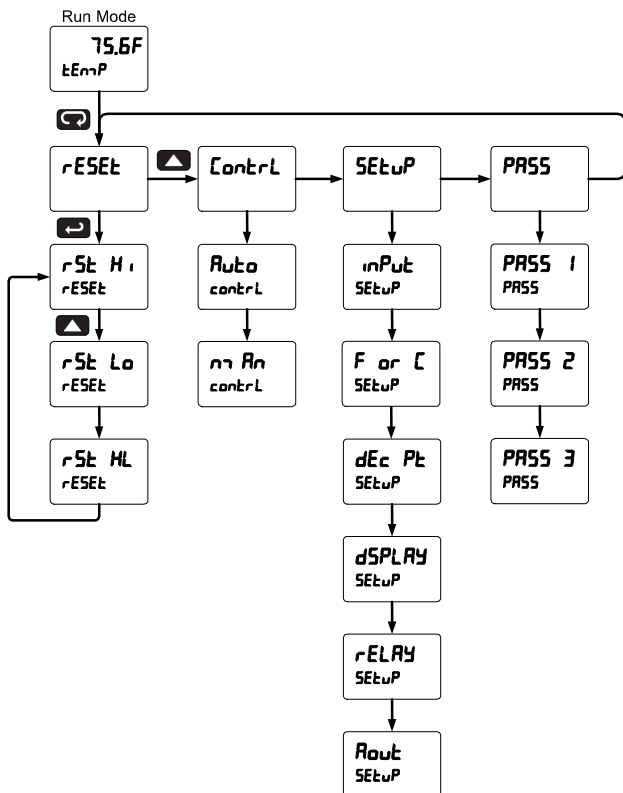

- Press Menu, at any time, to exit and return to Run Mode. Changes made to settings prior to pressing Enter are not saved.
- Changes to the settings are saved to memory only after pressing Enter.
- The display moves to the next menu every time a setting is accepted by pressing Enter.

Setting Numeric Values

The numeric values are set using the Right and Up arrow buttons. Press Right arrow to select next digit and Up arrow to increment digit value.

The digit being changed is displayed brighter than the rest.

Press the Enter button, at any time, to accept a setting or Menu button to exit without saving changes.

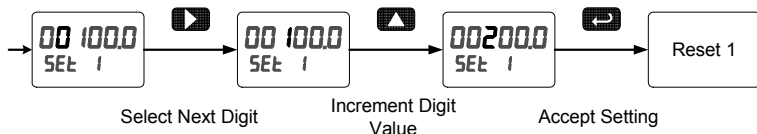

Reset Menu (rE5Et)

The *Reset* menu is used to reset the maximum or minimum reading (peak or valley) reached by the process; both may be reset at the same time by selecting “reset high & low” (r 5t HL).

Control Menu (ContrL)

The *Control* menu is used to control the 4-20 mA analog output and the relays manually, ignoring the input. Each relay and analog output can be programmed independently for manual control. Selecting automatic control sets all relays and analog output for automatic operation.

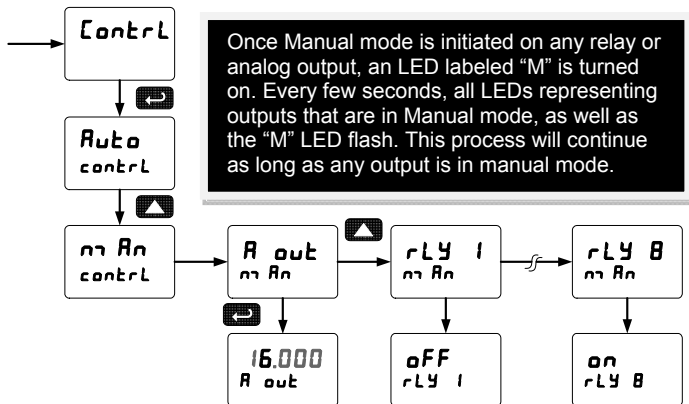

Setting Up the Meter (SETUP)

It is **very important** to read the following information, before proceeding to program the meter:

- The meter is factory calibrated prior to shipment to read temperature in degrees Fahrenheit. The calibration equipment is certified to NIST standards.
- There is no need to calibrate the meter, simply select the input type, °F or °C, and decimal point.

The *Setup* menu is used to select:

1. Input type the meter will accept
2. Degrees F or C
3. Decimal point position and F or C indication
4. Display parameter and intensity
5. Relay operation
6. 4-20 mA analog output scaling

Press the Enter button to access any menu or press Up arrow button to scroll through choices. Press the Menu button to exit at any time.

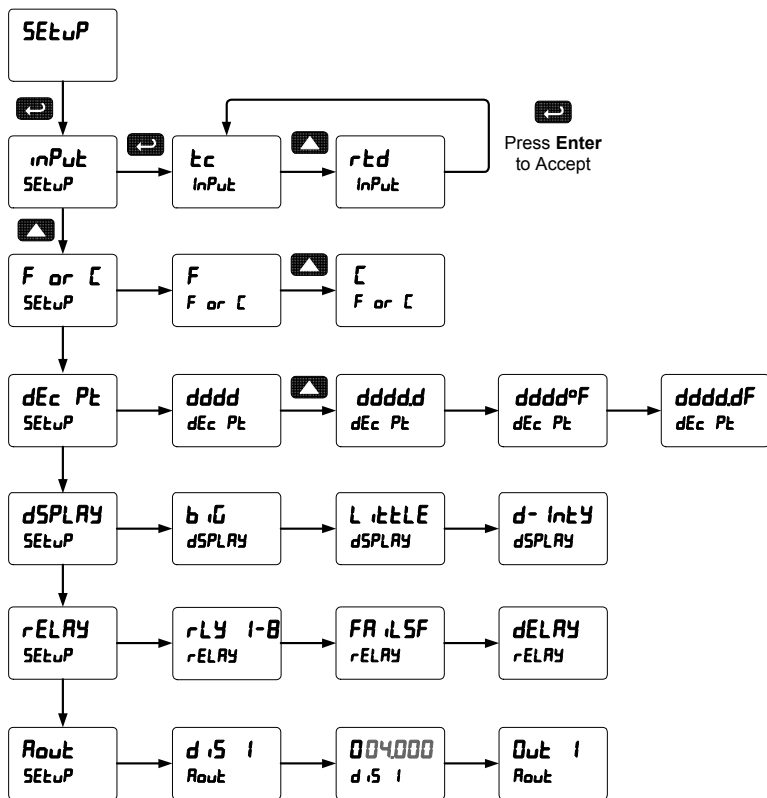

Setting the Input Signal (*INPUL*)

Enter the *Input* menu to set up the meter to accept thermocouple (*TC*) or RTD (*RTD*) inputs. The Type selector switch, located at the rear of the meter, must be set accordingly.

The thermocouple input is capable of accepting various types of thermocouples.

The RTD input is capable of accepting various types of RTD sensors. After selecting 100 Pt or 1000Pt, it is necessary to select either A385 (0.00385) or A392 (0.00392) coefficient.

Selecting the Temperature Scale (*F* or *C*)

The meter can display the temperature in degrees Fahrenheit or Celsius.

Setting the Decimal Point (*DEC Pt*)

The temperature may be displayed with one decimal or with no decimal point. The temperature scale can also be displayed with the reading. The degree symbol is available only with no decimal point selected.

Pressing the Up arrow scrolls the decimal point and temperature format selections.

Setting the Display Parameter & Intensity (*DISPLAY*)

The main display (*MAIN*) can be programmed to display:

1. Process value
2. Relay set points
3. Max & min values
4. Modbus input
5. Display reading and units

The small display (*SMALL*) can be programmed to display:

1. Process value
2. Relay set points
3. Max & min values
4. Engineering units or custom legends
5. Modbus input
6. Off (no display)
7. Display reading and units

Display Intensity: The meter has eight display intensity levels to give the best performance under various lighting conditions. Select intensity 8 for outdoor applications.

Display Setup Menu

- Press the Up arrow to change selection
- Press Enter to accept setting
- Press Menu to exit programming

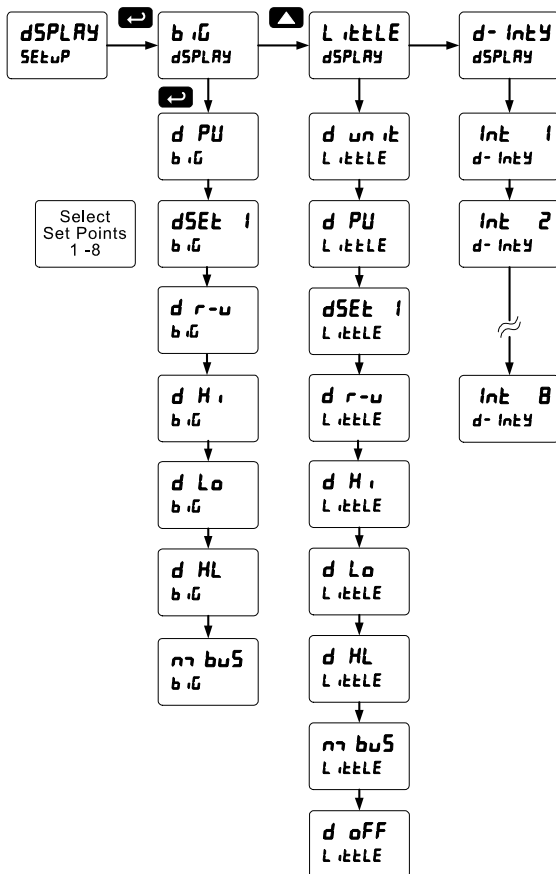

After setting up the input and display, press the Menu button to exit programming and skip the rest of the setup menu. Press the Menu button again and the Up arrow to reach the *Setup* menu again and complete the setup of the meter.

Character Set for Engineering Units Display (d unit)

The small display can be programmed to show engineering units or custom legends using the following 7-segment character set:

Display	Character
0	0
1	1
2	2
3	3
4	4
5	5
6	6
7	7
8	8
9	9
A	A
b	b
C	C
c	c
d	d
E	E
F	F
G	G
g	g
H	H
h	h
I	I
i	i
J	J

Display	Character
K	K
L	L
m	m
n	n
O	O
o	o
P	P
q	q
r	r
S	S
t	t
u	u
V	V
w	w
X	X
Y	Y
Z	Z
-	-
/	/
]]
[[
=	=
	Space
°	Degree

*Degree symbol (special non-ASCII character used)

The letters “m” and “w” use two 7-segment LEDs each; when selected the characters to the right are shifted one position.

See the flow chart 37 to access the display units menu.

Press and hold up arrow to auto-scroll the characters in the display.

Setting the Relay Operation (rELAY)

This menu is used to set up the operation of the relays.

CAUTION! *During setup, the relays do not follow the input and they will remain in the state found prior to entering the Relay menu.*

1. Relay action
 - a. Automatic reset only (non-latching)
 - b. Automatic + manual reset at any time (non-latching)
 - c. Latching (manual reset only)
 - d. Latching with Clear (manual reset only after alarm condition has cleared)
 - e. Relay alternation control (automatic reset only)
 - f. Sampling (the relay is activated for a user-specified time)
 - g. Off (relay disabled and Interlock feature enabled)
2. Set point
3. Reset point
4. Fail-safe operation
 - a. On (enabled)
 - b. Off (disabled)
5. Time delay
 - a. On delay (0-999.9 seconds)
 - b. Off delay (0-999.9 seconds)
6. Relay action for loss (break) of input (ignore, on, off)

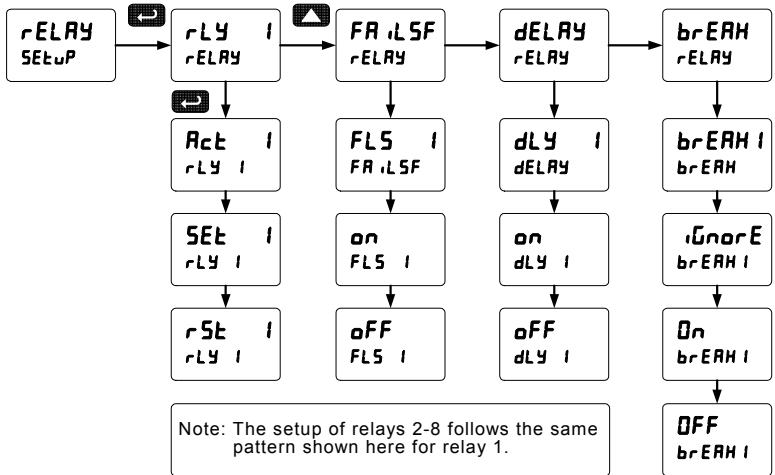

Setting the Relay Action

Operation of the relays is programmed in the *Action* menu. The relays may be set up for any of the following modes of operation:

1. Automatic reset (non-latching)
2. Automatic + manual reset at any time (non-latching)
3. Latching (manual reset only, at any time)
4. Latching with Clear (manual reset only after alarm condition has cleared)
5. Relay alternation control (automatic reset only)
6. Sampling (the relay is activated for a user-specified time)
7. Off (relay disabled and Interlock feature enabled)

The following graphic shows relay 1 action setup; relay 2-8 are set up in a similar fashion.

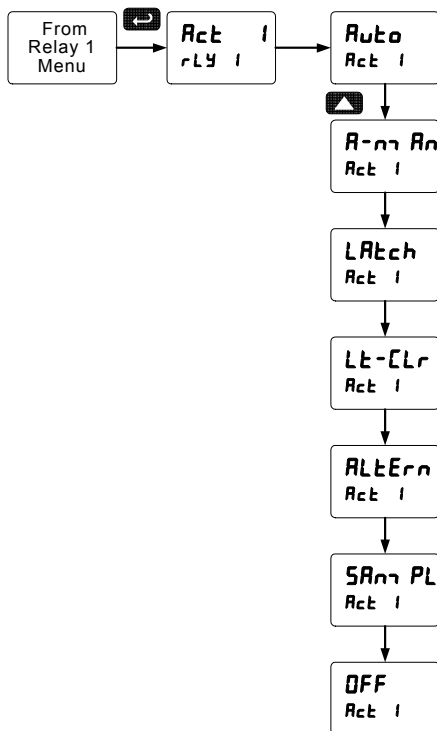

Programming Set and Reset Points

High alarm indication: program set point above reset point.

Low alarm indication: program set point below reset point.

The deadband is determined by the difference between set and reset points. Minimum deadband is one display count. If the set and reset points are programmed with the same value, the relay will reset one count below the set point.

Note: Changes are not saved until the reset point has been accepted.

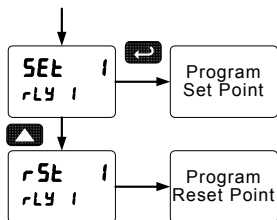

Setting Fail-Safe Operation

In fail-safe mode of operation, the relay coil is energized when the process variable is within safe limits and the relay coil is de-energized when the alarm condition exists. The fail-safe operation is set independently for each relay. Select **on** to enable or select **oFF** to disable fail-safe operation.

Programming Time Delay

The *On* and *Off* time delays may be programmed for each relay between 0 and 999.9 seconds. The relays will transfer only after the condition has been maintained for the corresponding time delay.

The *On* time delay is associated with the set point.

The *Off* time delay is associated with the reset point.

Relay Action for Loss of Input (Input Break)

Each relay may be programmed to go to one of the following conditions when the meter detects the loss of the input signal:

1. Turn *On* (Go to alarm condition)
2. Turn *Off* (Go to non-alarm condition)
3. Ignore (Processed as an upscale condition)

PROPLUS Software

The meter can also be programmed using the PC-based **PROPLUS** software available for free download at www.yokogawa-usa.com. Data logging for one meter at the time is available with **PROPLUS** software. More advanced data acquisition may be accomplished by using any Modbus RTU compliant software.

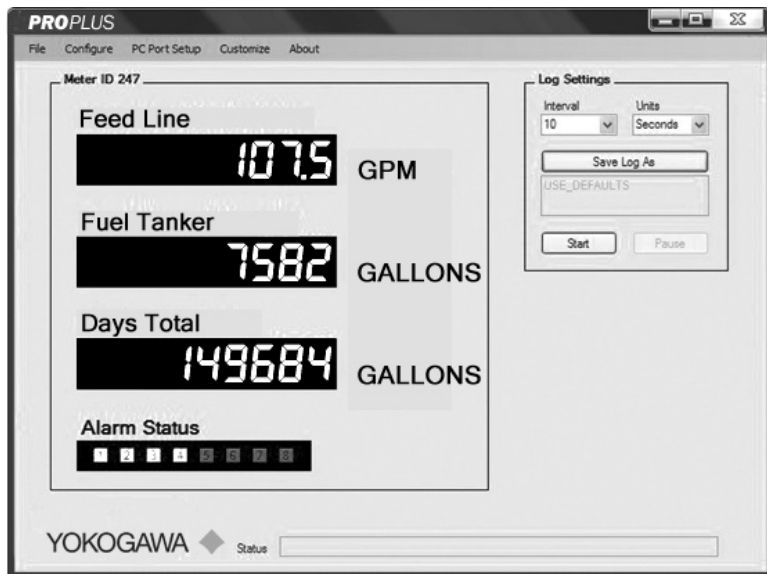

In order to program the meter using a computer, the meter must be connected using a USB, RS-232, or RS-485 serial adapter, see ORDERING INFORMATION on page 7 for details.

Relay and Alarm Operation Diagrams

The following graphs illustrate the operation of the relays, status LEDs, and ACK button.

High Alarm Operation (Set > Reset)

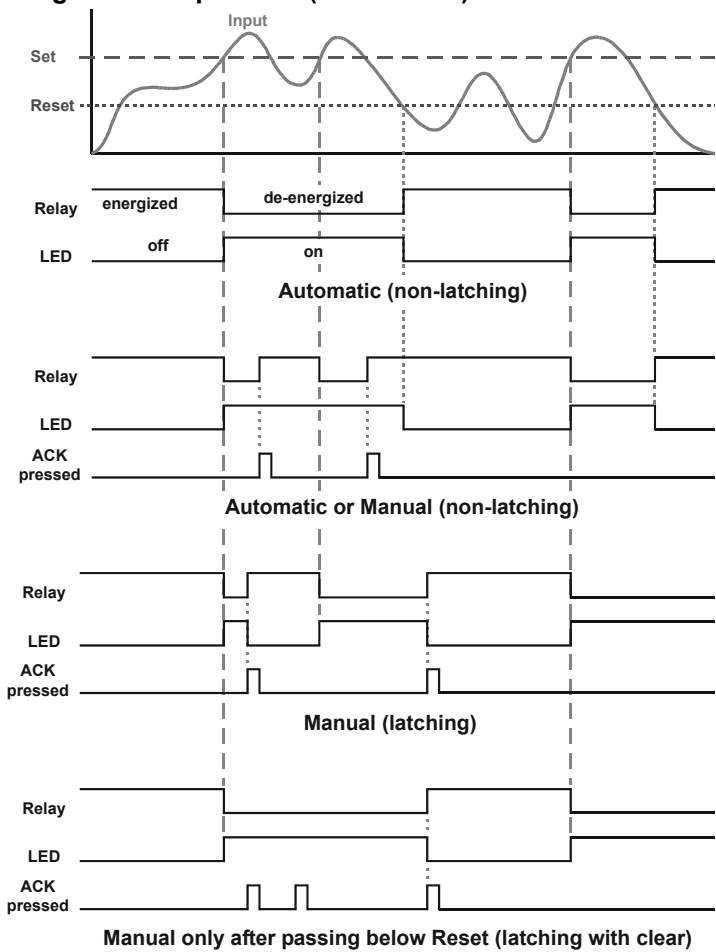

For Manual reset mode, ACK can be pressed anytime to turn "off" relay. To detect a new alarm condition, the signal must go below the set point, and then go above it.

Low Alarm Operation (Set < Reset)

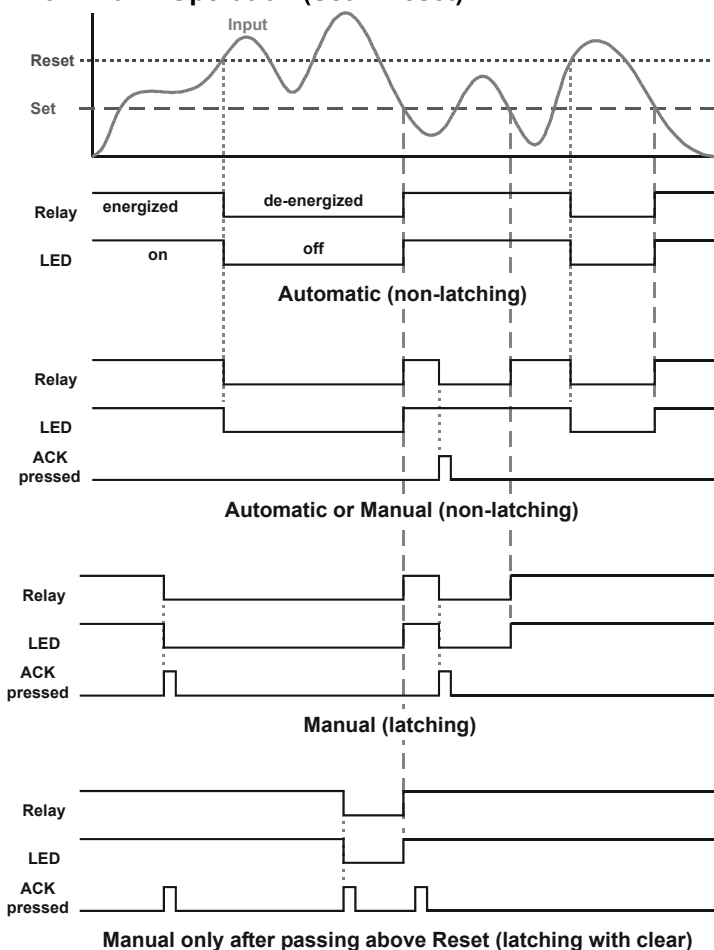

For Manual reset mode, ACK can be pressed anytime to turn "off" relay. For relay to turn back "on", signal must go above set point, and then go below it.

High Alarm with Fail-Safe Operation (Set > Reset)

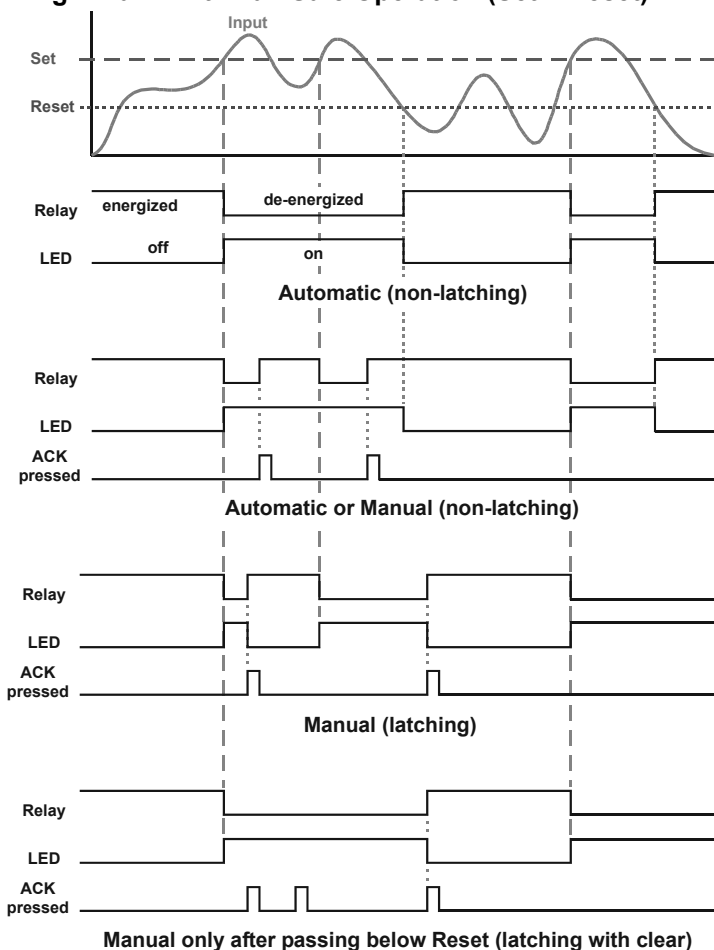

*Note: Relay coil is energized in non-alarm condition.
In case of power failure, relay will go to alarm state.*

Low Alarm with Fail-Safe Operation (Set < Reset)

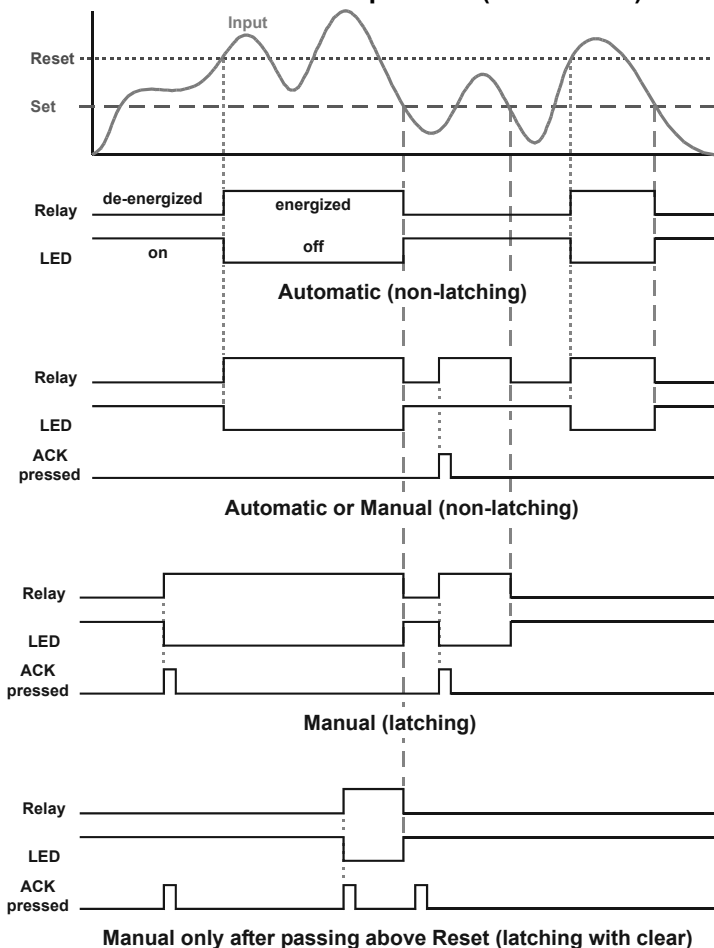

*Note: Relay coil is energized in non-alarm condition.
In case of power failure, relay will go to alarm state.*

Relay Alternation Control Operation

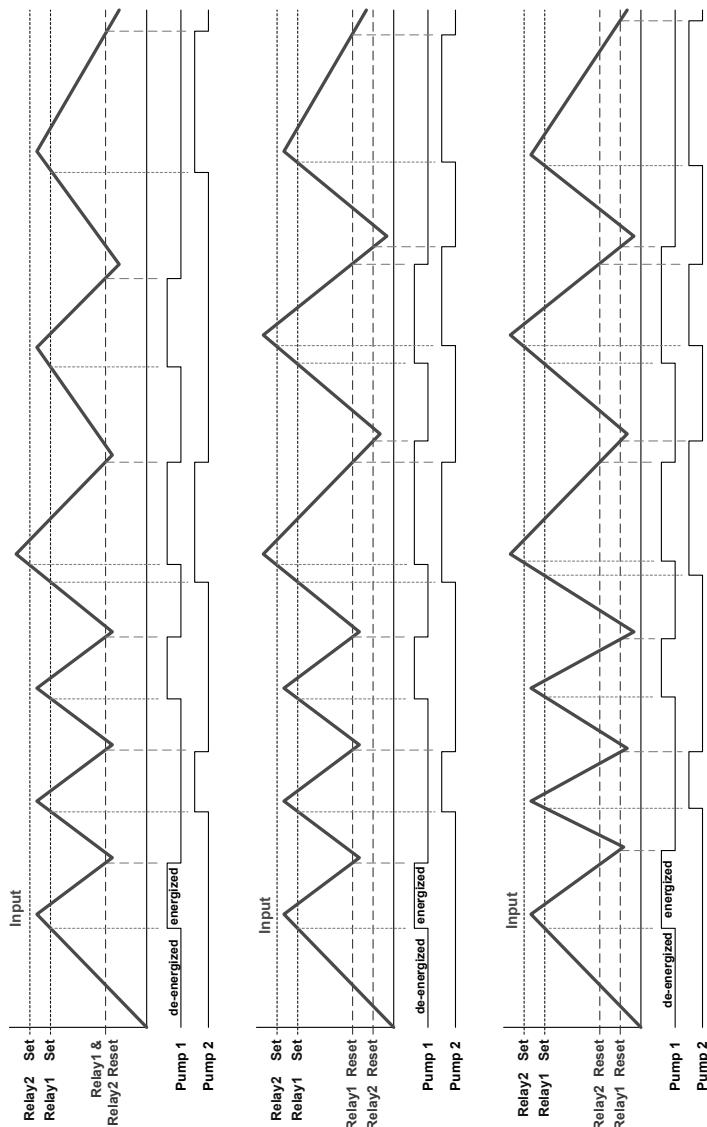

LEDs indicate the relay status

Relay Sampling Operation

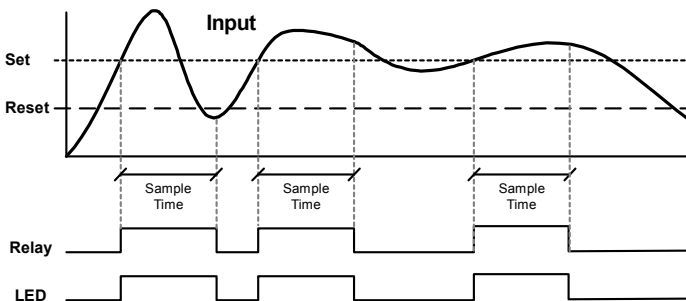

When the signal crosses the set point, the relay trips and the sample time starts. After the sample time has elapsed, the relay resets. The cycle repeats every time the set point is crossed, going up for high alarms and going down for low alarms.

The sample time can be programmed between 0.1 and 5999.9 seconds.

Signal Loss or Input Break Relay Operation

The following graph shows the input break relay operation for a high alarm relay.

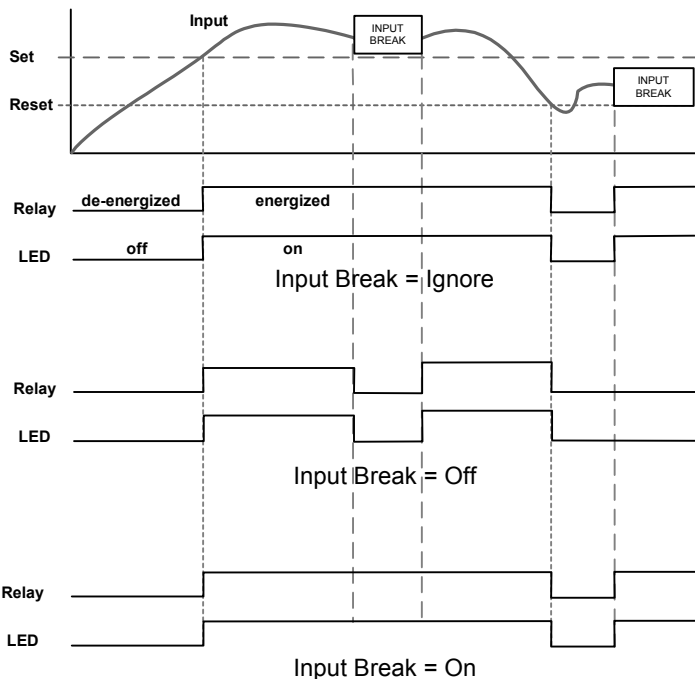

When the meter detects a break in the input, the relay will go to one of the following selected actions:

1. Turn *On* (Go to alarm condition)
2. Turn *Off* (Go to non-alarm condition)
3. Ignore (Processed as an upscale condition)

Time Delay Operation

The following graphs show the operation of the time delay function.

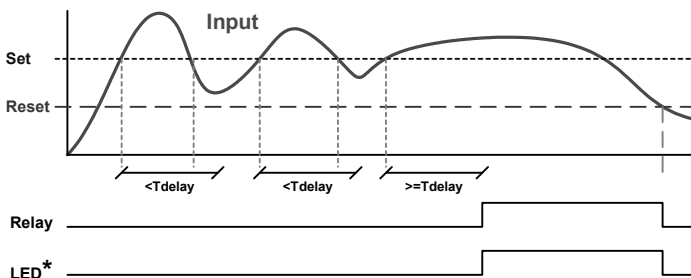

On Time Delay

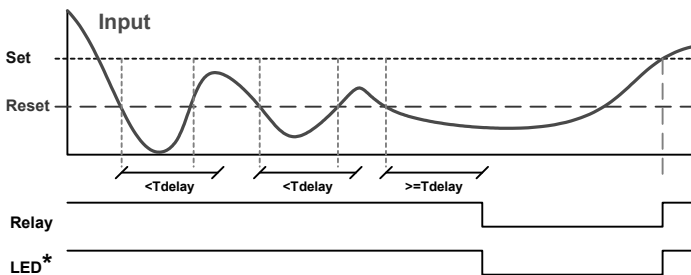

Off Time Delay

When the signal crosses the set point, the *On* time delay timer starts and the relay trips when the time delay has elapsed. If the signal drops below the set point (high alarm) before the time delay has elapsed, the *On* time delay timer resets and the relay does not change state. The same principle applies to the *Off* time delay.

* Note: If “*Automatic or Manual (A-MAN)*” reset mode is selected, the LED follows the reset point and not the relay state when the relay is acknowledged.

Relay Operation Details

Overview

The relay capabilities of the meter expand its usefulness beyond simple indication to provide users with alarm and control functions. These capabilities include front panel alarm status LEDs as well as either 2 or 4 optional internal relays and/or 4 external relays expansion module. Typical applications include high or low temperature alarms, control applications such as simple on/off temperature control. There are four basic ways the relays can be used:

1. High or Low Alarms with Latching or Non-Latching Relays
2. Simple On/Off Control with 100% Adjustable Deadband
3. Sampling (Based on Time)
4. Relay Alternation Control

Relays Auto Initialization

When power is applied to the meter, the front panel LEDs and alarm relays will reflect the state of the input to the meter. The following table indicates how the alarm LEDs and relays will react on power-up based on the set and reset points:

Alarm #	HI or LO Alarm	Set Point	Reset Point	Power-Up Reading	Relay & LED
1	HI	1000	500	499	Off
2	LO	700	900	499	On
3	LO	250	400	499	Off
4	HI	450	200	499	On

Fail-Safe Operation

The following table indicates how the relays behave based on the fail-safe selection for each relay:

Fail-Safe Selection	Non-Alarm State		Alarm State		Power Failure
	NO	NC	NO	NC	
Off	Open	Closed	Closed	Open	Relays go to non-alarm state
On	Closed	Open	Open	Closed	Relays go to alarm state

Note: NO = Normally Open, NC = Normally Closed. This refers to the condition of the relay contacts when the power to the meter is off.

Front Panel LEDs

The LEDs on the front panel provide status indication for the following:

LED	Status
1	Alarm 1
2	Alarm 2
3	Alarm 3
4	Alarm 4

LED	Status
5	Alarm 5
6	Alarm 6
7	Alarm 7
8	Alarm 8

The meter is supplied with four alarm points that include front panel LEDs to indicate alarm conditions. This standard feature is particularly useful for alarm applications that require visual-only indication. The LEDs are controlled by the set and reset points programmed by the user. When the display reaches a set point for a high or low alarm, the corresponding alarm LED will turn on. When the display returns to the reset point the LED will go off. The front panel LEDs respond differently for latching and non-latching relays.

For non-latching relays, the LED is always off during normal condition and always on during alarm condition, regardless of the state of the relay (e.g. Relay acknowledged after alarm condition).

For latching relays, the alarm LEDs reflect the status of the relays, regardless of the alarm condition. The following tables illustrate how the alarm LEDs function in relation to the relays and the acknowledge button (Default: F3 key assigned to ACK):

Latching and Non-Latching Relay Operation

The relays can be set up for latching (manual reset) or non-latching (automatic reset) operation.

Relay terminology for following tables

Terminology	Relay Condition
On	Alarm (Tripped)
Off	Normal (Reset)
Ack	Acknowledged

The On and Off terminology does not refer to the status of the relay's coil, which depends on the fail-safe mode selected.



In latching relay mode, latched relays will reset (unlatch) when power is cycled.

Warning!

Non-Latching Relay (Αυτο)**Automatic reset only**

Condition	LED	Relay
Normal	Off	Off
Alarm	On	On
Ack (No effect)	On	On
Normal	Off	Off

In this application, the meter is set up for automatic reset (non-latching relay). Acknowledging the alarm while it is still present has no effect on either the LED or the relay. When the alarm finally goes away, the relay automatically resets and the LED also goes off.

Non-Latching Relay (Α-ανάκληση)**Automatic + manual reset at any time**

Condition	LED	Relay
Normal	Off	Off
Alarm	On	On
Normal	Off	Off
Next Alarm	On	On
Ack	On	Off
Normal	Off	Off

In this application, the meter is set up for automatic and manual reset at any time (non-latching relay). The LED and the relay automatically reset when the meter returns to the normal condition.

The next time an alarm occurs, the operator acknowledges the alarm manually while the alarm condition still exists. This causes the relay to reset, but the LED stays on until the meter returns to the normal condition.

Latching Relay (Λαβύκι)**Manual reset any time**

Condition	LED	Relay
Normal	Off	Off
Alarm	On	On
Ack	Off	Off

In this application, the meter is set up for manual reset at any time. Acknowledging the alarm even if the alarm condition is still present resets the relay and turns off the LED.

Latching Relay (L_L-L_R)

Manual reset only after alarm condition has cleared

Condition	LED	Relay
Normal	Off	Off
Alarm	On	On
Ack (No effect)	On	On
Normal	On	On
Ack	Off	Off

In this application, the meter is set up for manual reset only after the signal passes the reset point (alarm condition has cleared). Acknowledging the alarm while it is still present has no effect on either the LED or the relay. When the alarm is acknowledged after it returns to the normal state, the LED and the relay go off. Notice that the LED remains on, even after the meter returns to the normal condition. This is because, for latching relays, the alarm LED reflects the status of the relay, regardless of the alarm condition.

Acknowledging Relays

There are two ways to acknowledge relays programmed for manual reset: via the programmable front panel function keys F1-F3 (Default: F3 assigned to ACK) and remotely via a normally open pushbutton connected across one of the digital inputs and the +5 V terminals on the digital I/O modules (Default: DI-4 assigned to ACK). When the ACK button or the assigned digital input is closed, all relays programmed for manual reset are acknowledged.

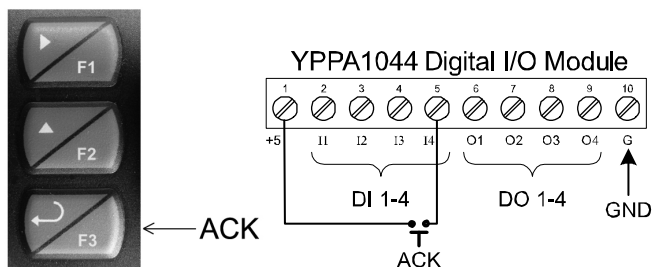
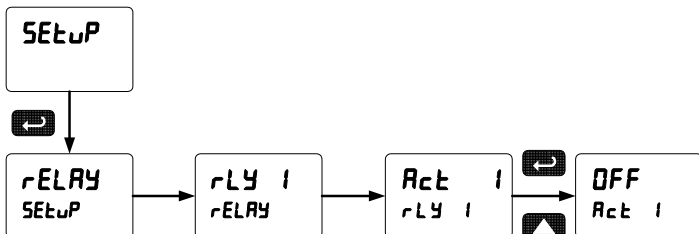

Figure 19. Acknowledge Relays w/Function Key or Digital Input

Setting Up the Interlock Relay (Force On) Feature

Relays 1-4 can be set up as interlock relays. To set up the relays for the interlock feature:

1. Access the *Setup – Relay – Action* menu and set the action to off.



2. In the *Advanced features – User* menu program any of the digital inputs to *Force On* any of the internal relays (1-4).

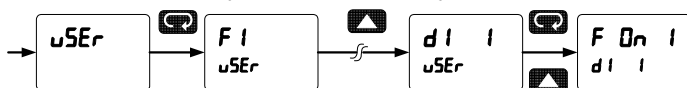

3. Connect a switch or dry contact between the +5V terminal and the corresponding digital input (dl-1 to dl-4) terminal.

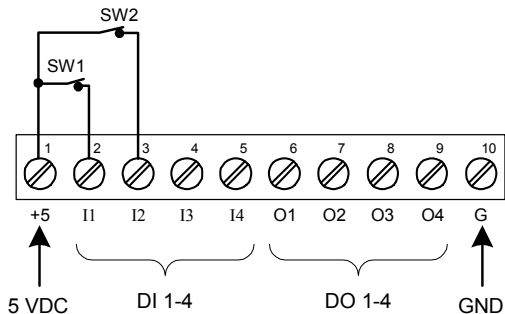

Interlock Relay Operation

Relays 1 & 2 are energized when SW1 & SW2 switches are closed and the front panel LEDs are off. If the contact to the digital input is opened, the corresponding front panel LED flashes indicating this condition. The processes being controlled by the interlock relay stop and will re-start only after the interlock relay is activated by the digital inputs.

Scaling the 4-20 mA Analog Output (*Rout*)

The 4-20 mA analog output can be scaled to provide a 4-20 mA signal for any display range selected.

No equipment is needed to scale the analog output; simply program the display values to the corresponding mA output signal.

The *Analog Output* menu is used to program the 4-20 mA output based on display values.

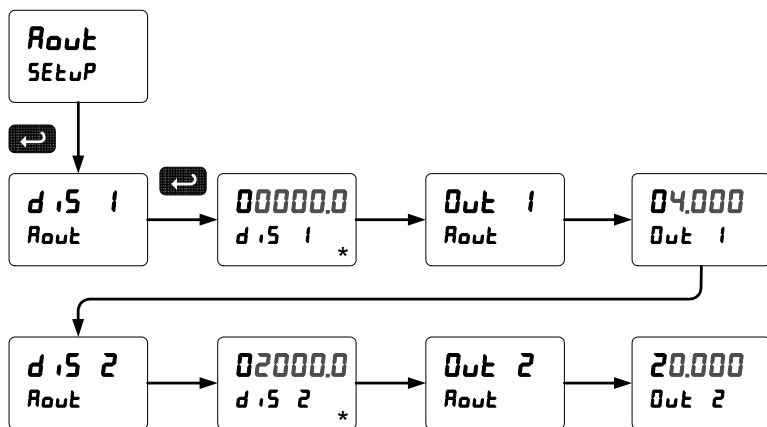

**Note: During the analog output scaling, the display value is always indicated with a decimal point regardless of the decimal point selection for the temperature display.*

For instructions on how to program numeric values see *Setting Numeric Values*, page 33.

Setting Up the Password (PASS)

The *Password* menu is used for programming three levels of security to prevent unauthorized changes to the programmed parameter settings.

Pass 1: Allows use of function keys and digital inputs

Pass 2: Allows use of function keys, digital inputs and editing set/reset points

Pass 3: Restricts all programming, function keys, and digital inputs.

Protecting or Locking the Meter

Enter the *Password* menu and program a six-digit password.

For instructions on how to program numeric values see *Setting Numeric Values*, page 33.

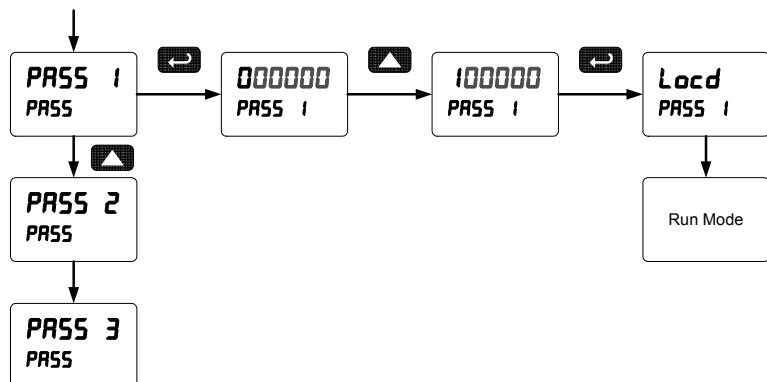

Record the password for future reference. If appropriate, it may be recorded in the space provided.

Model:	
Serial Number:	
Password 1:	__ __ __ __ __ __
Password 2:	__ __ __ __ __ __
Password 3:	__ __ __ __ __ __

Making Changes to a Password Protected Meter

If the meter is password protected, the meter will display the message *Locd* (*Locked*) when the Menu button is pressed. Press the Enter button while the message is being displayed and enter the correct password to gain access to the menu.

Note: After exiting the programming mode, the meter returns to its password protected condition.

Disabling Password Protection

To disable the password protection, access the *Password* menu and enter the correct password twice, as shown below. The meter is now unprotected until a new password is entered.

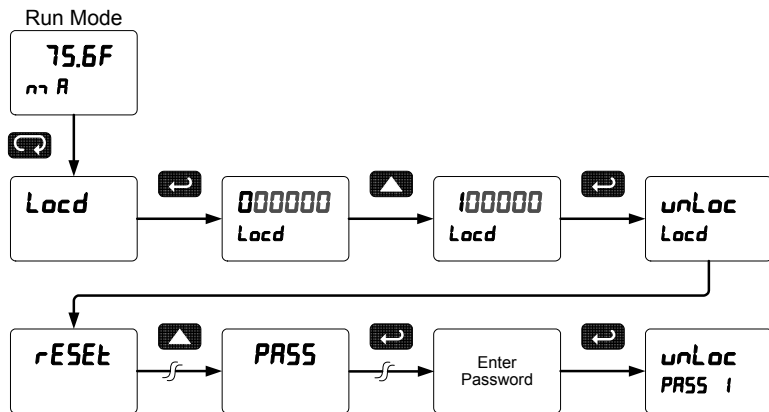

If the correct six-digit password is entered, the meter displays the message *unLoc* (*unlocked*) and the protection is disabled until a new password is programmed.

If the password entered is incorrect, the meter displays the message *Locd* (*Locked*) for about two seconds, and then it returns to Run Mode. To try again, press Enter while the *Locked* message is displayed.

Did you forget the password?

The password may be disabled by entering a master password once. If you are authorized to make changes, enter the master password 508655 to unlock the meter.

Advanced Features Menu

To simplify the setup process, functions not needed for most applications are located in the *Advanced Features* menu.

Press and hold the Menu button for three seconds to access the advanced features of the meter.

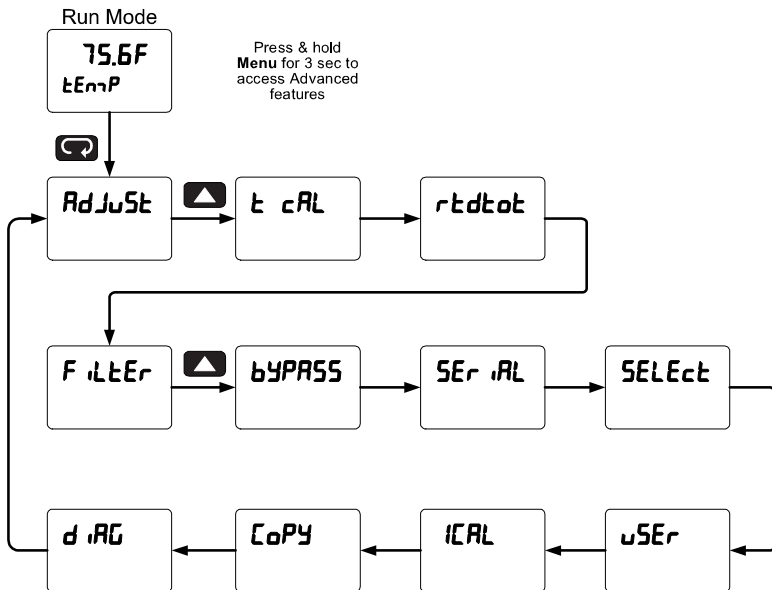

Advanced Features Menu & Display Messages

The following table shows the functions and messages of the *Advanced Features* menu in the order they appear in the menu.

Display	Parameter	Action/Setting
AdjLJSt	Adjust	Set adjust value to offset temperature reading
t cRL	T Cal	Enter temperature calibration menu
t Lo	T Low	Apply the low temperature input (e.g. 32°F)
t Hi	T High	Apply the high temperature input (e.g. 1000°F)
rtdtot	RTD Total	Set the number of RTDs connected in parallel to obtain average temperature
FiltEr	Filter	Set noise filter value
bYPASS	Bypass	Set filter bypass value
SEr iRL	Serial	Set serial communication parameters
SLAVE id	Slave ID	Set slave ID or meter address
bAud	Baud rate	Select baud rate
tr dLY	Transmit delay	Set transmit delay for serial communication
PAR itY	Parity	Select parity Even, Odd, or None with 1 or 2 stop bits
t-bytE	Time byte	Set byte-to-byte timeout
SELEct	Select	Enter the Select menu
RoUtPr	Analog output programming	Program analog output parameters
Source	Source	Select source for the 4-20 mA output
o-rrnG	Overrange	Program mA output for display overrange
u-rrnG	Underrange	Program mA output for display underrange
m RH	Maximum	Program maximum mA output allowed
m n	Minimum	Program minimum mA output allowed
LRl b	Calibrate	Calibrate 4-20 mA output (internal reference source used for scaling the output)
4 m R	4 mA output	Enter mA output value read by milliamp meter with at least 0.001 mA resolution

Display	Parameter	Action/Setting
20 mA	20 mA output	Enter mA output value read by milliamp meter with at least 0.001 mA resolution
USER	User I/O	Assign function keys and digital I/O
F1	F1 function key	Assign F1 function key
F2	F2 function key	Assign F2 function key
F3	F3 function key	Assign F3 function key
d 1 1	Digital input 1	Assign digital input 1- 8, if expansion modules are connected
d 0 1	Digital output 1	Assign digital output 1- 8, if expansion modules are connected
INTERNAL	Internal temp calibration	Enter internal temperature calibration (used for factory calibration only)
REF	Measured temp reference	Enter the measured reference temperature in degrees Celsius (e.g. 25.0)
0 mV	0 mV	Apply 0.000 mV input Internal Calibration
100 mV	100 mV	Apply 100.000 mV input
COPY	Copy	Enter copy function
SEND	Send	Send meter settings to another meter
DONE	Done	Copy function completed
DIAG	Diagnostics	Display parameter settings
LED T	LED test	Test all LEDs
INFO	Information	Display software and S/N information

Offset Adjust (Adjust)

This parameter allows the user to select an offset adjustment to the temperature being displayed. Offset adjustment values can be either positive or negative and can be any number within $\pm 50.0^\circ$. The offset adjustment value is programmed through the *Adjust* menu.

The offset adjustment feature can be useful to compensate for errors due to thermocouple junctions or excessive lead wire resistance in RTDs.

Note: The offset adjustment value is not reset to zero when the type of temperature sensor is changed (i.e. TC type or RTD curve). Celsius/Fahrenheit conversion must be made manually by the user.

Recalibration of the Meter (⌘ CAL)

The *Calibration* (⌘ CAL) menu is used to **recalibrate** the thermocouple and RTD inputs.

- The meter is factory calibrated prior to shipment to read temperature in degrees Fahrenheit. The calibration equipment is certified to NIST standards.
- There is no need to calibrate the meter, simply select the input type, °F or °C, and decimal point.
- Check calibration of the meter at least every 12 months.

Allow at least 30 minutes warm-up time before performing recalibration procedure to ensure specified accuracy.

Recommended Calibration Points

To recalibrate the meter, it is recommended to use the Fahrenheit scale; this will give a greater degree of accuracy to the calibration. The scale can be changed to the Celsius scale after calibration is completed. The meter will display temperature accurately in any scale. The following table shows the recommended low and high calibration points for all types.

Type of input	Input 1 (Low)	Input 2 (High)	Check (Middle)
Type J	32°F	1184°F	600°F
Type K	32°F	1895°F	960°F
Type T	32°F	698°F	360°F
Type E	32°F	1652°F	800°F
Type R	32°F	3110°F	1500°F
Type S	32°F	3110°F	1500°F
Type B	32°F	3110°F	1500°F
Type N	32°F	1472°F	700°F
Type C	500°F	3650°F	1800°F
10 Ω Cu RTD	32°F 9.035Ω	450°F 18.032Ω	200°F 12.639Ω
100 Ω Pt RTD (0.00385)	32°F 100Ω	1148°F 320.12Ω	590°F 215.61Ω
100 Ω Pt RTD (0.00392)	32°F 100Ω	1148°F 324.49Ω	590°F 217.89Ω
120 Ω Ni RTD	32°F 120Ω	410°F 315.31Ω	221°F 205.22Ω
1000 Ω Pt RTD (0.00385)	32°F 1000Ω	900°F 2750.4Ω	450°F 1876.5Ω
1000 Ω Pt RTD (0.00392)	32°F 1000Ω	900°F 2785.1Ω	450°F 1893.7Ω

Recalibration Procedure

1. Connect signal to the meter using the appropriate wire (e.g. type J thermocouple wire to recalibrate type J input), see page 19.
2. Set up the meter to accept the selected input (e.g. type J T/C), see page 36.
3. Set up the meter to display temperature in degrees Fahrenheit.
4. Apply signal corresponding to input 1 (32°F) and program the display to read 32.0.
5. Apply signal corresponding to input 2 (1184°F for type J) and program the display accordingly.
6. After the meter accepts input 2, the display returns to reading mode. This completes the recalibration procedure for the selected input.

Noise Filter (F LLEr)

The noise filter is available for unusually noisy signals that cause an unstable process variable display. The noise filter averages the input signal over a certain period. The filter level determines the length of time over which the signal is averaged. The filter level can be set between 2 and 199. The higher the filter level, the longer the averaging time and so the longer it takes the display to settle to its final value. Setting the filter level to zero disables the filter function.

Noise Filter Bypass (bYPR55)

The noise filter bypass changes the behavior of the meter so that small variations in the signal are filtered out but large abrupt changes in the input signal are displayed immediately. The bypass value determines the minimum amount of signal change to be displayed immediately. All signal changes smaller than the bypass value are filtered or averaged by the meter. The noise filter bypass may be set between 0.1 and 99.9% of full scale.

Modbus RTU Serial Communications (SEr ,AL)

The meter is equipped with serial communications capability as a standard feature using the Modbus RTU Serial Communication Protocol.

To communicate with a computer or other data terminal equipment, an RS-232 or RS-485 adapter option is required; see *Ordering Information* on page 7 for details.



Warning!

Do not connect any equipment other than Yokogawa's expansion modules, cables, or meters to the RJ45 M-LINK connector. Otherwise damage will occur to the equipment and the meter.

Note: More detailed instructions are provided with each optional serial communications adapter.

*Note: Refer to the **PROPLUS** Modbus Register Tables located at www.yokogawa-usa.com for details.*

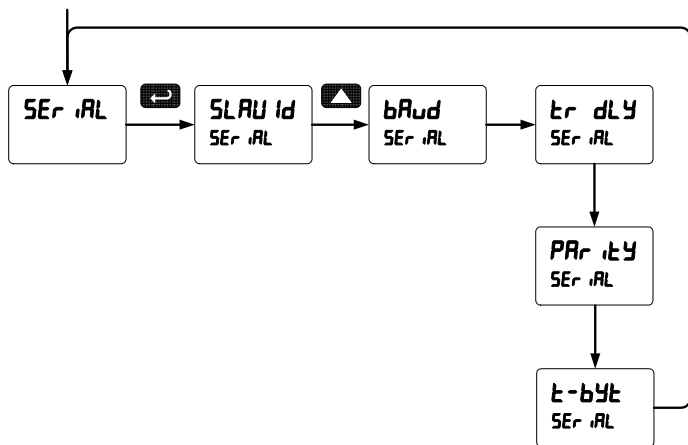

When using more than one meter in a multi-drop mode, each meter must have its own unique Slave ID or meter address. The ID or address may be programmed between 1 and 247. The transmit delay may be set between 0 and 199 ms. The parity can be set to even, odd, or none with 1 or 2 stop bits.

The YPP7000 can also be connected to another YPP7000 with a special YPPA1200 cable, allowing the user to copy all the settings from one meter to another, using the *Copy* function.

Select Menu (SELEct)

The *Select* menu is used to program the analog output parameters. There are no other selections for this model.

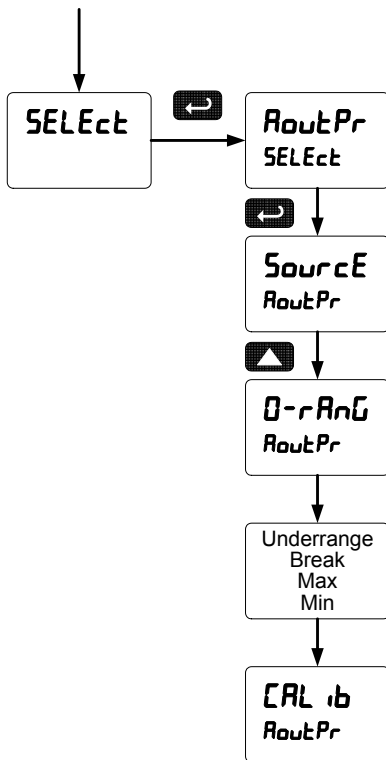

Analog Output Programming (*RoutPr*)

The *Analog Output Programming* menu is used to program the behavior of the 4-20 mA output. The following parameters and functions are programmed in this menu:

1. Source: Source for generating the 4-20 mA output (e.g. PV - temperature)
2. Overrange: Analog output value with display in overrange condition
3. Underrange: Analog output value with display in underrange condition
4. Break: Analog output value when input break is detected
5. Max: Maximum analog output value allowed regardless of input
6. Min: Minimum analog output value allowed regardless of input
7. Calibrate: Calibrate the internal 4-20 mA source reference used to scale the 4-20 mA output

Analog Output Source

The source for generating the 4-20 mA output may be assigned to the process variable, maximum or minimum value reached by the process, one of the set points, or the Modbus input.

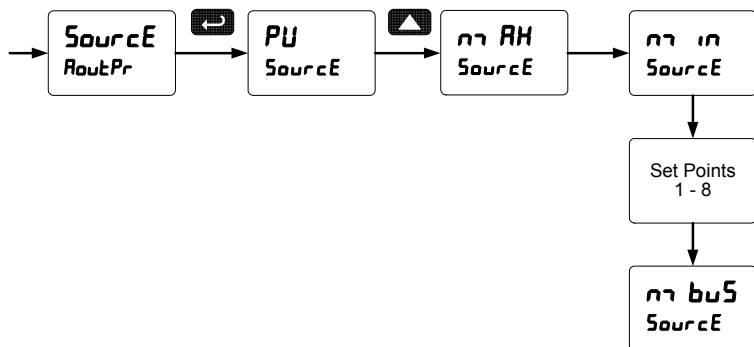

Analog Output Calibration

To perform the analog output calibration it is recommended to use a milliamp meter with a resolution of at least 0.1 μA to measure the output current. The values saved internally during this procedure are used for scaling the 4-20 mA output in the *Setup* menu.

Programmable Function Keys User Menu (uSEr)

The *User* menu allows the user to assign the front panel function keys F1, F2, F3 and up to eight digital inputs to access most of the menus or to activate functions immediately (e.g. Reset max & min). Up to eight digital outputs can be assigned to a number of actions and functions executed by the meter (e.g. Alarms, relay acknowledgement, etc.).

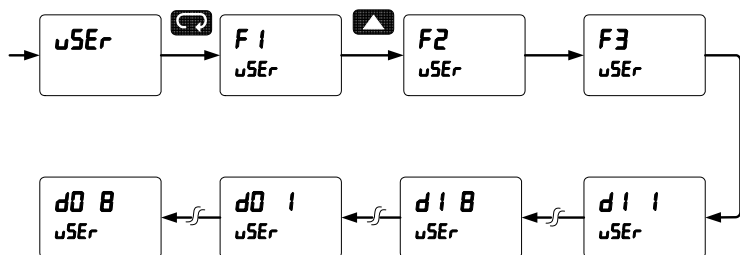

Function Keys & Digital I/O Available Settings

Display	Description	Display	Description
RcH	Acknowledge relays	L iE H i	Max on little display
rSt H i	Reset max	L iE Lo	Min on little display
rSt Lo	Reset min	L iE HL	Max/min little display
rSt HL	Reset max & min	d iSBbL	Disable function key
rELAY	Relay menu	rr Enu	Menu button
SEt 1	Set point 1 - 8	r iGht	Right arrow button/F1
rLY d	Disable all relays	uP	Up arrow button/F2
rLY E	Enable all relays	EntEr	Enter button/F3
o HoLd	Relays & output hold	ALn 1	Alarm 1 – 8
d HoLd	Display hold	F On 1	Force relay 1 on
b iG H i	Max on big display	F On 2	Force relay 2 on
b iG Lo	Min on big display	F On 3	Force relay 3 on
b iG HL	Max/min big display	F On 4	Force relay 4 on

Internal Temperature Calibration (ICAL)

The meter is factory calibrated prior to shipment to read temperature in degrees Fahrenheit. The calibration equipment is certified to NIST standards.

The Internal Calibration (ICAL) is a function used at the factory to calibrate all the thermocouple and RTD ranges. This procedure should only be used by qualified personnel.

To recalibrate the meter for a specific input and range, refer to page 63 Recalibration of the Meter (RCAL).

Notes:

1. *If meter is in operation and it is intended to accept only one input type (e.g. 100 Pt), recalibration of other inputs is not necessary.*
2. *Allow the meter to warm up for at least 30 minutes before performing the calibration procedure.*
3. *Use the Recalibration of the Meter (RCAL) procedure found on page 63.*

The *Internal calibration* menu is part of the *Advanced Features* menu and is described in the following pages. This procedure should only be used by qualified personnel.

Note: Most users should not require the use of the Internal Calibration procedure. The T CAL procedure should be used instead of the ICAL procedure.

Thermocouple Input Internal Calibration (ICAL)

1. Set the Type selector switch in the TC position and using copper wire connect a precision mV calibrator to the input.
2. In the *Setup* menu select the input: TC – Type J.
3. Press and hold the Menu button for three seconds to access the advanced features of the meter.
4. Press the Up arrow button to scroll to the *Internal calibration* menu (ICAL) and press Enter.
5. The meter displays either current calibration (REF). Press Enter to start the calibration process.
6. Measure the room temperature in degrees Celsius using a reliable reference, enter the room temperature (e.g. 25.0), and press Enter.
7. The meter displays 0 mV, apply an input equal to 0.000 mV and press Enter. The display flashes while accepting the 0 mV input; press Enter again when the display stops flashing.
8. The meter displays 100 mV, apply an input equal to 100.000 mV and press Enter. The display flashes while accepting the 100 mV input; press Enter again when the display stops flashing.
9. Apply 0 mV, the meter should read room temperature.
10. This completes the calibration of all the thermocouple ranges.

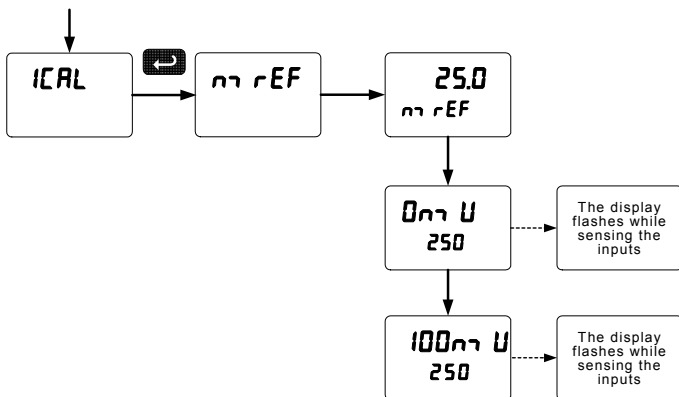

RTD Input Internal Calibration (ICAL)

1. Set the Type selector switch in the RTD position and the Range switch in the 10 position. Using 3 wires connect a precision calibrator resistance output to the meter.
2. In the *Setup* menu select the input: RTD – 100 Pt – A385.
3. Access the *Advanced Features* menu and scroll to the *ICAL* menu and press Enter.
4. The meter displays the message (*10 Lo*). Apply 9.035 ohm and press Enter. The display flashes for a moment while the meter is accepting the low input signal for the 10-ohm RTD. After the display stops flashing, press Enter again.
5. The meter displays the message (*10 Hi*). Apply 18.032 ohm and press Enter. The display flashes for a moment while the meter is accepting the high input signal for the 10-ohm RTD. After the display stops flashing, press Enter again.
6. The meter displays the message (*100 Lo*). **Do NOT press Enter.**
7. Move the Range selector switch to the 100 position. Apply 100 ohm and press Enter. The display flashes for a moment while the meter is accepting the low input signal for the 100-ohm RTD.
8. The meter displays the message (*100 Hi*). Apply 320.12 ohm and press Enter. The display flashes for a moment while the meter is accepting the high input signal for the 100-ohm RTD.
9. At the end of the calibration process the meter should read 1148.0F with the 320.12 ohm input applied.
10. This completes the calibration of all the RTD ranges.

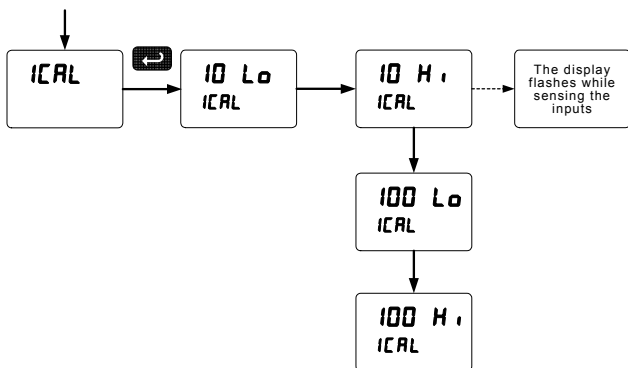

Meter Copy Function (Копия)

The *Copy* function is used to copy (or clone) all the settings from one meter to other meters requiring exactly the same setup and programming (*i.e.* type of input, decimal point, filter, bypass, etc.).



Warning!

Only the YPPA1200 meter copy cable must be used for meter-to-meter interfacing. The YPPA1200 is a special eight-conductor flat cable with two wires swapped.

Using standard CAT5 or other cable will cause damage to both meters.

YPPA1200 Meter Copy Cable



Figure 20. Meter Copy Connection

Copy Function Requirements

To successfully copy settings from one meter to another, both meters must have:

1. *Same software version*
2. *Same baud rate setting*

See Determining Software Version, page 77 for instructions.

Meter Copy or Cloning Instructions



Caution!

Do not connect the two meters to the same signal source while cloning. Internal calibration may be affected.

1. Connect two meters using a YPPA1200 meter copy cable.



Warning!

Using standard CAT5 or other cable will cause damage to both meters. Use YPPA1200 meter copy cable only.

2. Do not connect the two meters to the same signal source.
3. Power up both meters. Leave Clone meter in Run Mode.
4. Enter the *Advanced Features* menu of the Master meter; see *Advanced Features Menu* on page 60.
5. Scroll to the *Copy* function using the Up arrow button then press Enter.
6. The meter displays the message *SEnd*. Press Enter, the display flashes while sending data. The message *donE* is displayed when copying is completed.

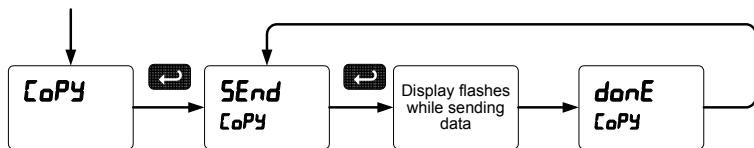

7. The Clone meter displays the message *CPY rE* while being programmed then the message *donE* when copying is completed. The meter initializes and returns to Run Mode using the same settings as the Master.
8. If meter to be cloned does not respond to the data being sent, refer to **Copy Function Requirements** above.





METER OPERATION

The meter is capable of accepting a variety of thermocouples and RTDs.

The dual-line display can be customized by the user to operate in such a way as to satisfy a specific application. Typically the main display is used for the process variable; while the second display is used engineering units, custom legend, or set point indication.

Additionally the meter can be set up to display the thermocouple or RTD input on the main display and the Modbus input on the second display. The relays and analog output can be programmed to operate from the Modbus PV input.

Front Panel Buttons Operation

Button Symbol	Description
	Press to enter or exit Programming Mode, view settings, or exit max/min readings
	Press to reset max/min readings or other parameter/function assigned through the <i>User</i> menu
	Press to display max/min readings or other parameter/function assigned through the <i>User</i> menu
	Press to acknowledge relays or other parameters/function assigned through the <i>User</i> menu

Function Keys Operation

During operation, the programmable function keys operate according to the way they have been programmed in the *Advanced Features – User* menu.

The table above shows the factory default settings for F1, F2, and F3.

Maximum/Minimum Readings

The max & min readings (peak & valley) reached by the process can be displayed either continuously or momentary:

1. Display briefly by assigning to the F1-F3 function keys or to the digital inputs in the *User* menu.
2. Display continuously by assigning either display to max/min through the *Display* menu.

Any of the F1-F3 function keys (buttons) and the digital inputs can be programmed to reset the max & min readings. The meters are set at the factory to display the max reading by pressing the Up arrow/F2 button and to use the Right arrow/F1 button to access the *Reset* menu.

To display max reading using function key with factory defaults:

1. Press Up arrow/F2 button to display maximum reading since the last reset/power-up.
2. To reset max/min press Right arrow/F1 button to access the Reset menu. The max & min displays are reset to actual values.
3. Press Menu to exit max/min display reading.

To display max/min readings continuously:

Assign either display to Max (d H i), Min (d L o), or toggle between Max and Min (d HL) every 10 seconds.

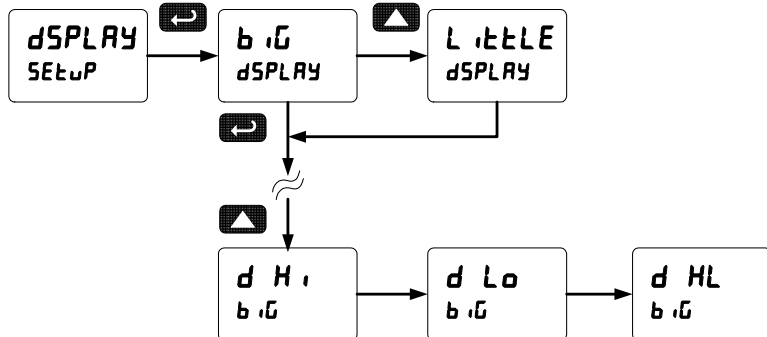

TROUBLESHOOTING

The rugged design and the user-friendly interface of the meter should make it unusual for the installer or operator to refer to this section of the manual. However, due to the many features and functions of the meter, it's possible that the setup of the meter does not agree with what an operator expects to see.

If the meter is not working as expected, refer to the *Diagnostics* menu and recommendations below.

Diagnostics Menu (d iRG)

The *Diagnostics* menu is located in the *Advanced Features* menu, to access *Diagnostics* menu see *Advanced Features Menu*, page 60.

It provides an easy way to view the programmed parameter settings for troubleshooting purposes. Press the Enter button to view the settings and the Menu button to exit at any time.

For a description of the diagnostic messages, see *Advanced Features Menu & Display Messages*, page 61.

Determining Software Version

To determine the software version of a meter:

1. Go to the *Diagnostics* menu (d iRG) and press Enter button.
2. Press Up arrow button and scroll to Information menu (iRFd).
3. Press Enter to access the software number (5Ft) and version (UER) information. Write down the information as it is displayed. Continue pressing Enter until all the information is displayed.
4. The meter returns to Run Mode after displaying all the settings.

Reset Meter to Factory Defaults

When the parameters have been changed in a way that is difficult to determine what's happening, it might be better to start the setup process from the factory defaults.

Instructions to load factory defaults:

1. Enter the *Advanced Features* menu. See *Advanced Features Menu*, page 60.
2. Press Up arrow to go to *Diagnostics* menu
3. Press and hold Right arrow for five seconds, press Enter when display flashes *rESEt*.
Note: If Enter is not pressed within three seconds, the display returns to the *Diagnostics* menu.
4. The meter goes through an initialization sequence (similar as on power-up), and loads the factory default settings.

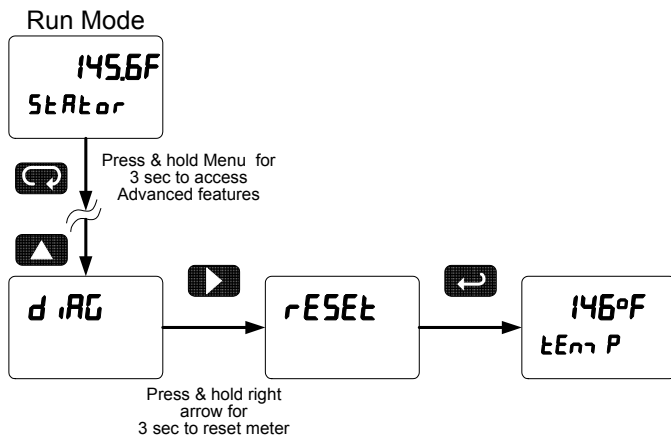

Factory Defaults & User Settings

The following table shows the factory setting for most of the programmable parameters on the meter. Next to the factory setting, the user may record the new setting for the particular application.

Model: _____ S/N: _____ Date: _____

Parameter	Display	Default Setting	User Setting
Input type	<i>inPut</i>	Type J TC	
Temp scale	<i>F or C</i>	°F	
Adjust	<i>AdJusT</i>	0.0	
RTD total	<i>rtdtot</i>	1	
Filter	<i>FiLteR</i>	70	
Bypass	<i>bYPASS</i>	0.2	
Decimal point	<i>ddd°F</i>	No decimal	
Display assignment	<i>dSPLaY</i>		
Big display (Main)	<i>b i</i>	PV: Temperature	
Little display (Small)	<i>L i t t l E</i>	Eng units: Temp	
Display intensity	<i>d- intY</i>	8	
Relay 1 action	<i>Act 1</i>	Automatic	
Relay 1 set point	<i>SEt 1</i>	100	
Relay 1 reset point	<i>rSt 1</i>	50	
Relay 2 action	<i>Act 2</i>	Automatic	
Relay 2 set point	<i>SEt 2</i>	200	
Relay 2 reset point	<i>rSt 2</i>	150	
Relay 3 action	<i>Act 3</i>	Automatic	
Relay 3 set point	<i>SEt 3</i>	300	
Relay 3 reset point	<i>rSt 3</i>	250	
Relay 4 action	<i>Act 4</i>	Automatic	
Relay 4 set point	<i>SEt 4</i>	400	

Parameter	Display	Default Setting	User Setting
Relay 4 reset point	<i>rSt 4</i>	350	
Fail-safe relay 1	<i>FLS 1</i>	Off	
Fail-safe relay 2	<i>FLS 2</i>	Off	
Fail-safe relay 3	<i>FLS 3</i>	Off	
Fail-safe relay 4	<i>FLS 4</i>	Off	
On delay relay 1	<i>On 1</i>	0.0 sec	
Off delay relay 1	<i>OFF 1</i>	0.0 sec	
On delay relay 2	<i>On 2</i>	0.0 sec	
Off delay relay 2	<i>OFF 2</i>	0.0 sec	
On delay relay 3	<i>On 3</i>	0.0 sec	
Off delay relay 3	<i>OFF 3</i>	0.0 sec	
On delay relay 4	<i>On 4</i>	0.0 sec	
Off delay relay 4	<i>OFF 4</i>	0.0 sec	
Input break relay 1	<i>IGNoRE</i>	Ignore	
Input break relay 2	<i>IGNoRE</i>	Ignore	
Input break relay 3	<i>IGNoRE</i>	Ignore	
Input break relay 4	<i>IGNoRE</i>	Ignore	
Display 1 analog out	<i>d iS 1</i>	0.0	
Output 1 value	<i>Out 1</i>	4.000 mA	
Display 2 analog out	<i>d iS 2</i>	2000.0	
Output 2 value	<i>Out 2</i>	20.000 mA	
Source analog output	<i>Source</i>	Process Variable	
Overrange output	<i>OverRnG</i>	21.000 mA	
Underrange output	<i>u-rRnG</i>	3.000 mA	
Input break output	<i>brEAK</i>	1.000 mA	
Maximum output	<i>mA RH</i>	23.000 mA	

Parameter	Display	Default Setting	User Setting
Minimum output	<i>m m</i>	0.000 mA	
Slave ID	<i>SLAVE id</i>	247	
Baud rate	<i>bAUD</i>	9600	
Transmit delay	<i>tr dLY</i>	10 ms	
Parity	<i>PAR itY</i>	Even	
Byte-to-byte timeout	<i>t-byt</i>	010 (0.1 sec)	
F1 function key	<i>F 1</i>	Reset max & min	
F2 function key	<i>F 2</i>	Big display: Max (Hi)	
F3 function key	<i>F 3</i>	Acknowledge relays	
Digital input 1	<i>d i 1</i>	Menu	
Digital input 2	<i>d i 2</i>	Right arrow	
Digital input 3	<i>d i 3</i>	Up arrow	
Digital input 4	<i>d i 4</i>	Enter	
Digital output 1	<i>dO 1</i>	Alarm 1	
Digital output 2	<i>dO 2</i>	Alarm 2	
Digital output 3	<i>dO 3</i>	Alarm 3	
Digital output 4	<i>dO 4</i>	Alarm 4	
Password 1	<i>PRSS 1</i>	000000 (unlocked)	
Password 2	<i>PRSS 2</i>	000000 (unlocked)	
Password 3	<i>PRSS 3</i>	000000 (unlocked)	

Troubleshooting Tips

Symptom	Check/Action
No display at all	Check power at power connector
Not able to change setup or programming, <i>LoCd</i> is displayed	Meter is password-protected, enter correct six-digit password to unlock
Meter displays error message during calibration (<i>Error</i>)	Check: <ol style="list-style-type: none"> 1. Signal connections 2. Type and range selector switches 3. Input selected in <i>Setup</i> menu
Meter displays <ol style="list-style-type: none"> 1. <i>99999</i> 2. <i>-9999</i> 	Check: <ol style="list-style-type: none"> 1. Input selected in <i>Setup</i> menu 2. Corresponding signal at Signal connector
Display is unstable	Check: <ol style="list-style-type: none"> 1. Input signal stability and value 2. Filter and bypass values (increase)
Display response is too slow	Check filter and bypass values
Display reading is not accurate	Check: <ol style="list-style-type: none"> 1. TC wire type 2. Input selection in <i>Setup</i> menu
Display does not respond to input changes, reading a fixed number	Check: <ol style="list-style-type: none"> 1. Display assignment, it might be displaying max, min, or set point.
Display alternates between <ol style="list-style-type: none"> 1. <i>H i</i> and a number 2. <i>Lo</i> and a number 	Press Menu to exit max/min display readings.
Relay operation is reversed	Check: <ol style="list-style-type: none"> 1. Fail-safe in <i>Setup</i> menu 2. Wiring of relay contacts
Relay and status LED do not respond to signal	Check: <ol style="list-style-type: none"> 1. Relay action in <i>Setup</i> menu 2. Set and reset points
Flashing relay status LEDs	Relays in manual control mode or relay interlock switches opened.
Meter not communicating with application programs	Check: <ol style="list-style-type: none"> 1. Serial adapter and cable 2. Serial settings 3. Meter address and baud rate
If the display locks up or the meter does not respond at all	Cycle the power to reboot the microprocessor.
Other symptoms not described above	Call Technical Support for assistance.

DIMENSIONS

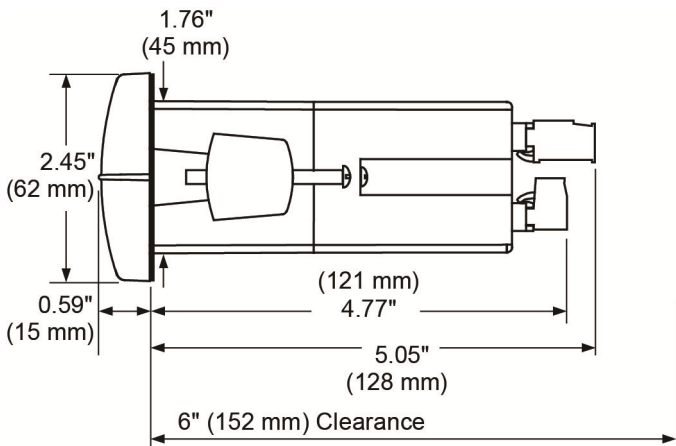

Figure 21. Meter Dimensions - Side View

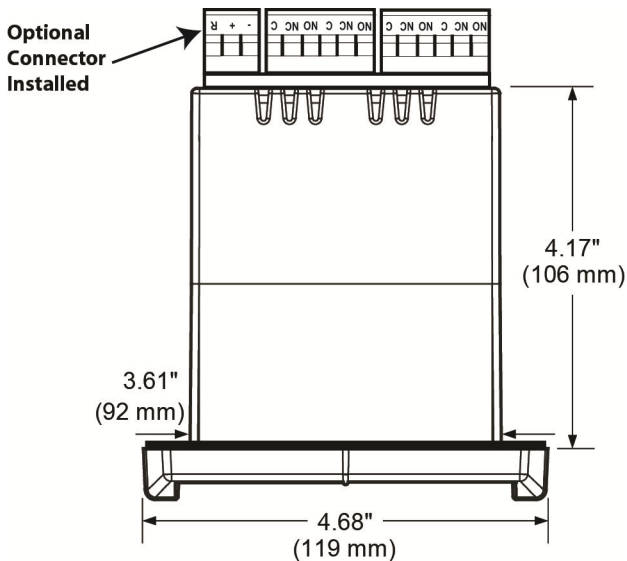

Figure 22. Meter Dimensions - Top View

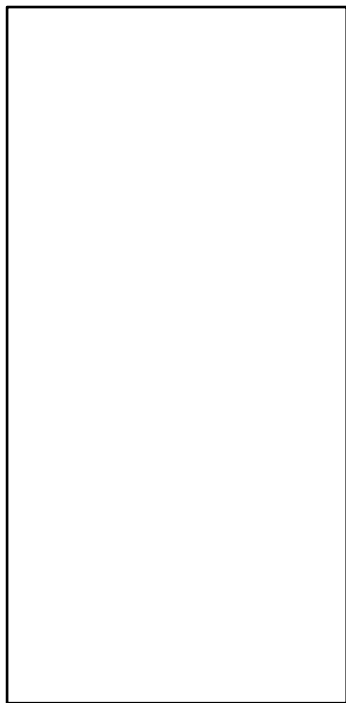

Figure 23: 1/8 DIN Panel Cutout Template

How to Contact Yokogawa Corporation of America

- For Sales and Technical Support please
Call: (800) 888-6400 or (770) 254-0400
Fax: (770) 251-2088
Email: meters-instr@us.yokogawa.com
- For the latest version of this manual please visit
www.yokogawa-usa.com