

# YPP6200 Analog Input Rate/Totalizer Instruction Manual



**PROPLUS**



- 0-20 mA, 4-20 mA, 0-5 V, 1-5 V,  $\pm 10$  V Inputs
- NEMA 4X, IP65 Front
- Universal 85-265 VAC, or 12/24 VDC Input Power Models
- Large Dual-Line 6-Digit Display, 0.60" & 0.46"
- Dual-Scale for Level Applications – Single Input
- Sunlight Readable Display Models
- Isolated 24 VDC @ 200 mA Transmitter Power Supply
- Signal Input Conditioning for Flow & Round Horizontal Tanks
- Programmable Displays & Function Keys
- Rate Displayed as Units per Second, Minute, Hour, or Day
- Total, Grand Total or Non-Resettable Grand Total
- 9-Digit Totalizer with Total Overflow Feature
- 32-Point Linearization, Square Root, or Programmable Exponent
- Multi-Pump Alternation Control
- 2 or 4 Relays + Isolated 4-20 mA Output for Rate or Total
- External 4-Relays & Digital I/O Expansion Modules
- USB, RS-232 & RS-485 Serial Communication Options
- Modbus<sup>®</sup> RTU Communication Protocol Standard
- Tare Function
- Free **PROPLUS** Software for Operation, Monitoring, and Programming

**YOKOGAWA** ◆

2 Dart Road • Newnan, Georgia 30265

770-253-7000 • 800-888-6400

Fax: 770-251-2088 • [www.yokogawa-usa.com](http://www.yokogawa-usa.com)

## Disclaimer

The information contained in this document is subject to change without notice. Yokogawa Corporation of America makes no representations or warranties with respect to the contents hereof and specifically disclaims any implied warranties of merchantability or fitness for a particular purpose.



**CAUTION:** Read complete instructions prior to installation and operation of the meter.



**WARNING:** Risk of electric shock or personal injury.



## Warning!

This product is not recommended for life support applications or applications where malfunctioning could result in personal injury or property loss. Anyone using this product for such applications does so at his/her own risk. Yokogawa Corporation of America shall not be held liable for damages resulting from such improper use.

## Limited Warranty

Yokogawa Corporation of America warrants this product against defects in material or workmanship for the specified period under "Specifications" from the date of shipment from the factory. Yokogawa's liability under this limited warranty shall not exceed the purchase value, repair, or replacement of the defective unit.

## Registered Trademarks

All other trademarks mentioned in this document are the property of their respective owners.

© 2011 Yokogawa Corporation of America. All rights reserved.

[www.yokogawa-usa.com](http://www.yokogawa-usa.com)

## Table of Contents

<b>INTRODUCTION</b>	<b>6</b>
<b>ORDERING INFORMATION</b>	<b>7</b>
<b>SPECIFICATIONS</b>	<b>8</b>
General	8
Process Input	9
Rate/Totalizer	10
Relays	11
Isolated 4-20 mA Transmitter Output	12
Modbus® RTU Serial Communications	13
YPPA1044 Digital Input & Output Expansion Module	13
<b>COMPLIANCE INFORMATION</b>	<b>14</b>
Safety	14
Electromagnetic Compatibility	14
<b>SAFETY INFORMATION</b>	<b>15</b>
<b>INSTALLATION</b>	<b>16</b>
Unpacking	16
Panel Mounting Instructions	16
Configuration for 12 or 24 VDC Power Option	18
Transmitter Supply Voltage Selection (P+, P-)	19
Connections	19
Connectors Labeling	20
Power Connections	20
Signal Connections	21
Modbus RTU Serial Communications	22
Relay Connections	22
Switching Inductive Loads	23
4-20 mA Output Connections	24
Analog Output Transmitter Power Supply	24
External Relay & Digital I/O Connections	25
Interlock Relay Feature	26
<b>SETUP AND PROGRAMMING</b>	<b>27</b>
Front Panel Buttons and Status LED Indicators	28
Display Functions and Messages	29
Main Menu	33
Setting Numeric Values	34

<b>Reset Menu (rESEt)</b> -----	<b>34</b>
<b>Control Menu (Control)</b> -----	<b>34</b>
<b>Setting Up the Rate/Totalizer Meter (SEtUP)</b> -----	<b>35</b>
Setting the Input Signal (inPUt) -----	36
Setting the Totalizer Features (tOtAL) -----	36
Dual-Scale for Level Application -----	37
Setting the Decimal Point (dEc Pnt) -----	38
Programming the Rate/Totalizer (PrOG) -----	38
Multi-Point Calibration & Scaling -----	39
<b>PROPLUS</b> Software -----	39
Scaling the Meter (SEALE) -----	39
Time Base, Total Conversion Factor & Total Reset -----	42
Calibrating the Meter with External Source (CAL) -----	43
Setting the Display Parameter & Intensity (dSPLEAY) -----	44
Display Setup Menu -----	45
Character Set for Engineering Units Display (dUnIt) -----	46
<b>Setting the Relay Operation (rELAY)</b> -----	<b>47</b>
Relay Assignment (R55 iOn) -----	48
Setting the Relay Action -----	49
Programming Set and Reset Points -----	50
Setting Fail-Safe Operation -----	50
Programming Time Delay -----	50
Relay Action for Loss of 4-20 mA Input (Loop Break) -----	50
<b>Relay and Alarm Operation Diagrams</b> -----	<b>51</b>
High Alarm Operation (Set > Reset) -----	51
Low Alarm Operation (Set < Reset) -----	52
High Alarm with Fail-Safe Operation (Set > Reset) -----	53
Low Alarm with Fail-Safe Operation (Set < Reset) -----	54
Pump Alternation Control Operation -----	55
Rate Relay Sampling Operation -----	56
Total Relay Sampling Operation -----	56
Signal Loss or Loop Break Relay Operation -----	57
Time Delay Operation -----	58
<b>Relay Operation Details</b> -----	<b>59</b>
Overview -----	59
Relays Auto Initialization -----	59
Fail-Safe Operation -----	59
Front Panel LEDs -----	60
Latching and Non-Latching Relay Operation -----	60
Non-Latching Relay (RULtO) -----	61
Non-Latching Relay (R-nLRn) -----	61
Latching Relay (LRtCH) -----	61
Latching Relay (Lt-CLR) -----	62

<b>Model YPP6200 Analog Input Rate/Totalizer</b>	<b>Instruction Manual</b>
Acknowledging Relays -----	62
Pump Alternation Control Applications ( <i>RLtErn</i> ) -----	63
Setting Up the Interlock Relay (Force On) Feature -----	66
<b>Scaling the 4-20 mA Analog Output (<i>Rout</i>) -----</b>	<b>67</b>
<b>Setting Up the Password (<i>PR55</i>) -----</b>	<b>68</b>
Protecting or Locking the Meter -----	68
Total Reset Password & Non-Resettable Total -----	69
Making Changes to a Password Protected Meter -----	70
Disabling Password Protection -----	70
<b>Advanced Features Menu -----</b>	<b>71</b>
Advanced Features Menu & Display Messages -----	72
Noise Filter ( <i>FiltEr</i> ) -----	75
Noise Filter Bypass ( <i>bYPR55</i> ) -----	75
Modbus RTU Serial Communications ( <i>SERiAL</i> ) -----	76
Select Menu ( <i>SELEct</i> ) -----	77
Signal Input Conditioning ( <i>FunctiOn</i> ) -----	77
Low-Flow Cutoff ( <i>LwLFF</i> ) -----	80
Analog Output Programming ( <i>RoutPr</i> ) -----	80
Programmable Function Keys User Menu ( <i>uSER</i> ) -----	81
Tare ( <i>tArE</i> ) -----	82
Internal Source Calibration ( <i>iCAL</i> ) -----	82
Meter Copy Function ( <i>CoPY</i> ) -----	85
<b>METER OPERATION -----</b>	<b>87</b>
<b>Front Panel Buttons Operation -----</b>	<b>87</b>
<b>Function Keys Operation -----</b>	<b>87</b>
<b>Maximum/Minimum Readings -----</b>	<b>88</b>
<b>TROUBLESHOOTING -----</b>	<b>89</b>
<b>Diagnosics Menu (<i>d iAG</i>) -----</b>	<b>89</b>
Determining Software Version -----	89
<b>Reset Meter to Factory Defaults -----</b>	<b>90</b>
Factory Defaults & User Settings -----	91
<b>Troubleshooting Tips -----</b>	<b>95</b>
<b>Alphabetical List of Display Functions &amp; Messages -----</b>	<b>96</b>

## Table of Figures

Figure 1: 1/8 DIN Panel Cutout and Mounting.....	16
Figure 2: Meter Dimensions - Side View.....	17
Figure 3: Meter Dimensions - Top View.....	17
Figure 4: Jumper Configuration for 12/24 VDC Power.....	18
Figure 5: Transmitter Supply Voltage Selection.....	19
Figure 6: Connector Labeling for Fully Loaded YPP6200.....	20
Figure 7: Power Connections.....	20
Figure 8: Transmitters Powered by Internal Supply.....	21
Figure 9: Transmitter Powered by Ext. Supply or Self-Powered.....	21
Figure 10: Voltage Input Connections.....	22
Figure 11: Relay Connections.....	22
Figure 12: AC and DC Loads Protection.....	23
Figure 13: Low Voltage DC Loads Protection.....	23
Figure 14: 4-20 mA Output Connections.....	24
Figure 15: Expansion Modules & DIN Rail Mounting Kit.....	25
Figure 16: External Relays Module Connections.....	25
Figure 17: Digital I/O Module Connections.....	26
Figure 18: Interlock Connection.....	26
Figure 19: Acknowledge Relays w/Function Key or Digital Input...	62
Figure 20: Meter Copy Connection.....	85
Figure 21: 1/8 DIN Panel Cutout Template.....	103

## INTRODUCTION

The **PROPLUS** YPP6200 is a multipurpose, easy to use rate/totalizer ideal for flow rate, total, and control applications. It accepts current and voltage signals (e.g. 4-20 mA, 0-10 V). Three of the front panel buttons can be custom-programmed for specific operation.

The basic model includes an isolated 24 VDC transmitter power supply that can be used to power the input transmitter or other devices. An additional isolated 24 VDC power supply is included with the 4-20 mA output option.

A fully loaded YPP6200 rate/totalizer meter has the following: four SPDT relays, 4-20 mA output, and two 24 VDC power supplies. The YPP6200 capabilities may be enhanced by adding the following external expansion modules: four SPST relays (creating an eight-relay rate/totalizer), two digital I/O modules with four inputs and four outputs each, and USB, RS-232 or RS-485 communication adapters.

The eight relays can be used for alarm indication or process control applications. The 4-20 mA isolated output, Modbus RTU serial communications, and digital I/O options make the YPP6200 an excellent addition to any system.

**ORDERING INFORMATION****Standard Models**

<b>85-265 VAC Model</b>	<b>12/24 VDC Model</b>	<b>Options Installed</b>
YPP6200-6R0	YPP6200-7R0	No options
YPP6200-6R2	YPP6200-7R2	2 relays
YPP6200-6R3	YPP6200-7R3	4-20 mA output
YPP6200-6R4	YPP6200-7R4	4 relays
YPP6200-6R5	YPP6200-7R5	2 relays & 4-20 mA output
YPP6200-6R7	YPP6200-7R7	4 relays & 4-20 mA output

**SunBright Display Models**

<b>85-265 VAC Model</b>	<b>12/24 VDC Model</b>	<b>Options Installed</b>
YPP6200-6H0	YPP6200-7H0	No options
YPP6200-6H2	YPP6200-7H2	2 relays
YPP6200-6H3	YPP6200-7H3	4-20 mA output
YPP6200-6H4	YPP6200-7H4	4 relays
YPP6200-6H5	YPP6200-7H5	2 relays & 4-20 mA output
YPP6200-6H7	YPP6200-7H7	4 relays & 4-20 mA output

**Accessories**

<b>Model</b>	<b>Description</b>
YPPA1002	DIN rail mounting kit for two expansion modules
YPPA1004	4 SPST (Form A) relays
YPPA1044	4 digital inputs & 4 digital outputs (2 may be connected)
YPPA1200	Meter copy cable
YPPA1232	RS-232 serial adapter
YPPA1485	RS-485 serial adapter
YPPA8008	USB serial adapter
YPPA7485-I	RS-232 to RS-422/485 isolated converter
YPPA7485-N	RS-232 to RS-422/485 non-isolated converter
YPPA8232-N	USB to RS-232 non-isolated converter
YPPA8485-I	USB to RS-422/485 isolated converter
YPPA8485-N	USB to RS-422/485 non-isolated converter
YPPX6901	Suppressor (snubber): 0.01 $\mu$ F/470 $\Omega$ , 250 VAC

**Enclosures**

<b>Model</b>	<b>Description</b>
YPPA2811	1 Meter Plastic NEMA 4X Enclosure
YPPA2812	2 Meter Plastic NEMA 4X Enclosure

## SPECIFICATIONS

*Except where noted all specifications apply to operation at +25°C.*

### General

<b>DISPLAY</b>	Main display: 0.6" (15 mm) high, red LEDs Second display: 0.46" (12 mm) high, red LEDs 6 digits: each (-99999 to 999999), with lead zero blanking.
<b>DISPLAY INTENSITY</b>	Eight user selectable intensity levels
<b>DISPLAY UPDATE RATE</b>	5/second (200 ms)
<b>OVERRANGE</b>	Display flashes <b>999999</b>
<b>UNDERRANGE</b>	Display flashes <b>-99999</b>
<b>DISPLAY ASSIGNMENT</b>	The main (Big) and small (Little) displays may be assigned to rate, total, grand total, alternate rate & total, max/min, units (small display only), set points, and Modbus input.
<b>PROGRAMMING METHODS</b>	Four front panel buttons, digital inputs, PC and <b>PROPLUS</b> software, or cloning using Copy function.
<b>NOISE FILTER</b>	Programmable from 2 to 199 (0 will disable filter)
<b>FILTER BYPASS</b>	Programmable from 0.1 to 99.9% of calibrated span
<b>RECALIBRATION</b>	All ranges are calibrated at the factory. Recalibration is recommended at least every 12 months.
<b>MAX/MIN DISPLAY</b>	Max/min readings reached by the process are stored until reset by the user or until power to the meter is turned off.
<b>PASSWORD</b>	Three programmable passwords restrict modification of programmed settings and two prevent resetting the totals. Pass 1: Allows use of function keys and digital inputs Pass 2: Allows use of function keys, digital inputs and editing set/reset points Pass 3: Restricts all programming, function keys, and digital inputs. Total: Prevents resetting the total manually Gtotal: Prevents resetting the grand total manually
<b>NON-VOLATILE MEMORY</b>	All programmed settings are stored in non-volatile memory for a minimum of ten years if power is lost.
<b>POWER OPTIONS</b>	85-265 VAC 50/60 Hz, 90-265 VDC, 20 W max or jumper selectable 12/24 VDC $\pm$ 10%, 15 W max
<b>FUSE</b>	Required external fuse: UL Recognized, 5 A max, slow blow; up to 6 meters may share one 5 A fuse
<b>ISOLATED TRANSMITTER POWER SUPPLY</b>	Terminals P+ & P-: 24 VDC $\pm$ 5% @ 200 mA max (standard), (12/24 VDC powered models rated @ 100 mA max). 5 or 10 VDC @ 50 mA max, selectable with internal jumper J4.



<b>NORMAL MODE REJECTION</b>	Greater than 60 dB at 50/60 Hz
<b>ISOLATION</b>	4 kV input/output-to-power line 500 V input-to-output or output-to-P+ supply
<b>OVERVOLTAGE CATEGORY</b>	Installation Overvoltage Category II: Local level with smaller transient overvoltages than Installation Overvoltage Category III.
<b>ENVIRONMENTAL</b>	Operating temperature range: -40 to 65°C Storage temperature range: -40 to 85°C Relative humidity: 0 to 90% non-condensing
<b>CONNECTIONS</b>	Removable screw terminal blocks accept 12 to 22 AWG wire, RJ45 for external relays, digital I/O, and serial communication adapters.
<b>ENCLOSURE</b>	1/8 DIN, high impact plastic, UL 94V-0, color: black
<b>MOUNTING</b>	1/8 DIN panel cutout required: 3.622" x 1.772" (92 mm x 45 mm) Two panel mounting bracket assemblies are provided.
<b>TIGHTENING TORQUE</b>	Screw terminal connectors: 5 lb-in (0.56 Nm)
<b>OVERALL DIMENSIONS</b>	4.68" x 2.45" x 5.64" (119 mm x 62 mm x 143 mm) (W x H x D)
<b>WEIGHT</b>	9.5 oz (269 g)
<b>WARRANTY</b>	3 years parts & labor

## Process Input

<b>INPUTS</b>	Field selectable: 0-20, 4-20 mA, $\pm 10$ V (0-5, 1-5, 0-10 V), Modbus PV (Slave)
<b>ACCURACY</b>	$\pm 0.03\%$ of calibrated span $\pm 1$ count, square root & programmable exponent accuracy range: 10-100% of calibrated span
<b>TEMPERATURE DRIFT</b>	0.005% of calibrated span/ $^{\circ}$ C max from 0 to 65 $^{\circ}$ C ambient, 0.01% of calibrated span/ $^{\circ}$ C max from -40 to 0 $^{\circ}$ C ambient
<b>SIGNAL INPUT CONDITIONING</b>	Linear, square root, programmable exponent, or round horizontal tank volume calculation
<b>MULTI-POINT LINEARIZATION</b>	2 to 32 points
<b>PROGRAMMABLE EXPONENT</b>	1.0001 to 2.9999
<b>LOW-FLOW CUTOFF</b>	0-999999 (0 disables cutoff function)

<b>DECIMAL POINT</b>	Up to five decimal places or none: <i>d.dddddd, d.ddddd, d.dddd, d.ddd, d.dd, d.d, or ddddddd</i>
<b>CALIBRATION RANGE</b>	Input Minimum Span Range Input 1 & Input 2 4-20 mA 0.15 mA ±10 V 0.10 V An error message will appear if the input 1 and input 2 signals are too close together.
<b>INPUT IMPEDANCE</b>	Voltage ranges: greater than 1 MΩ Current ranges: 50 - 100 Ω (depending on resettable fuse impedance)
<b>INPUT OVERLOAD</b>	Current input protected by resettable fuse, 30 VDC max. Fuse resets automatically after fault is removed.

## Rate/Totalizer

<b>DISPLAY ASSIGNMENT</b>	The main (Big) and small (Little) displays may be assigned to rate, total, grand total, alternate R & T, units, and set point.
<b>RATE DISPLAY INDICATION</b>	-99999 to 999999, lead zero blanking. "R" LED illuminates while displaying rate.
<b>TOTAL DISPLAY &amp; TOTAL OVERFLOW</b>	0 to 999,999; automatic lead zero blanking. "T" LED is illuminated while displaying total or grand total. Up to 999,999,999 with total-overflow feature. "OF" is displayed to the left of total overflow and ▲ LED is illuminated.
<b>ALTERNATING DISPLAY</b>	Either display may be programmed to alternate between rate and total or rate and grand total every 10 seconds.
<b>TOTAL DECIMAL POINT</b>	Up to five decimal places or none: <i>d.dddddd, d.ddddd, d.dddd, d.ddd, d.d, or ddddddd</i> Total decimal point is independent of rate decimal point.
<b>TOTALIZER</b>	Calculates total based on rate and field programmable multiplier to display total in engineering units. Time base must be selected according to the time units in which the rate is displayed.
<b>TOTALIZER ROLLOVER</b>	Totalizer rolls over when display exceeds 999,999,999. Relay status reflects display.
<b>TOTAL OVERFLOW OVERRIDE</b>	Program total reset for automatic with 0.1 second delay and set point 1 for 999,999
<b>TOTALIZER PRESETS</b>	Up to eight, user selectable under setup menu. Any set point can be assigned to total and may be programmed anywhere in the range of the meter for total alarm indication.

<b>PROGRAMMABLE DELAY ON RELEASE</b>	0.1 and 999.9 seconds; applied to the first relay assigned to total or grand total. If the meter is programmed to reset total to zero automatically when the preset is reached, then a delay will occur before the total is reset.
<b>TOTAL RESET</b>	Via front panel button, external contact closure on digital inputs, automatically via user selectable preset value and time delay, or through serial communications.
<b>TOTAL RESET PASSWORD</b>	Total and grand total passwords may be entered to prevent resetting the total or grand total from the front panel.
<b>NON-RESETTABLE TOTAL</b>	The grand total can be programmed as a non-resettable total by entering the password "050873".
	 <p>Once the Grand Total has been programmed as "non-resettable" the feature <b>cannot</b> be disabled.</p> <p><b>Caution!</b></p>

## Relays

<b>RATING</b>	2 or 4 SPDT (Form C) internal and/or 4 SPST (Form A) external; rated 3 A @ 30 VDC and 125/250 VAC resistive load; 1/14 HP ( $\approx$ 50 W) @ 125/250 VAC for inductive loads
<b>NOISE SUPPRESSION</b>	Noise suppression is recommended for each relay contact switching inductive loads; see page 23 for details.
<b>RELAY ASSIGNMENT</b>	Relays may be assigned to rate, total, or grand total.
<b>DEADBAND</b>	0-100% of span, user programmable
<b>HIGH OR LOW ALARM</b>	User may program any alarm for high or low trip point. Unused alarm LEDs and relays may be disabled (turn off).
<b>RELAY OPERATION</b>	Automatic (non-latching) Latching (requires manual acknowledge) Sampling (based on time) Pump alternation control (2 to 8 relays) Off (disable unused relays and enable Interlock feature) Manual on/off control mode
<b>RELAY RESET</b>	User selectable via front panel buttons, digital inputs, or PC <ol style="list-style-type: none"> <li>Automatic reset only (non-latching), when the input passes the reset point or total is reset to zero.</li> <li>Automatic + manual reset at any time (non-latching)</li> <li>Manual reset only, at any time (latching)</li> <li>Manual reset only after alarm condition has cleared (L)</li> </ol> <p><i>Note: Front panel button or digital input may be assigned to acknowledge relays programmed for manual reset.</i></p>

<b>TIME DELAY</b>	0 to 999.9 seconds, on & off relay time delays Programmable and independent for each relay.
<b>FAIL-SAFE OPERATION</b>	Programmable and independent for each relay. <i>Note: Relay coil is energized in non-alarm condition. In case of power failure, relay will go to alarm state.</i>
<b>AUTO INITIALIZATION</b>	When power is applied to the meter, relays will reflect the state of the input to the meter.

## Isolated 4-20 mA Transmitter Output

<b>OUTPUT SOURCE</b>	Rate/process, total, grand total, max, min, set points 1-8, or manual control mode		
<b>SCALING RANGE</b>	1.000 to 23.000 mA for any display range.		
<b>CALIBRATION</b>	Factory calibrated: 4.000 to 20.000 = 4-20 mA output		
<b>ANALOG OUT PROGRAMMING</b>	23.000 mA maximum for all parameters: Overrange, underrange, max, min, and break		
<b>ACCURACY</b>	$\pm 0.1\%$ FS $\pm 0.004$ mA		
<b>TEMPERATURE DRIFT</b>	0.4 $\mu\text{A}/^\circ\text{C}$ max from 0 to 65°C ambient, 0.8 $\mu\text{A}/^\circ\text{C}$ max from -40 to 0°C ambient <i>Note: Analog output drift is separate from input drift.</i>		
<b>ISOLATED TRANSMITTER POWER SUPPLY</b>	Terminals I+ & R: 24 VDC $\pm 5\%$ @ 40 mA maximum; may be used to power the 4-20 mA output or other devices. Refer to Figure 6 on page 20 and Figure 14 on page 24.		
<b>EXTERNAL LOOP POWER SUPPLY</b>	35 VDC maximum		
<b>OUTPUT LOOP RESISTANCE</b>	Power supply	Minimum	Maximum
	24 VDC	10 $\Omega$	700 $\Omega$
	35 VDC (external)	100 $\Omega$	1200 $\Omega$

**Modbus® RTU Serial Communications**

<b>SLAVE ID</b>	1 – 247 (Meter address)
<b>BAUD RATE</b>	300 - 19,200 bps
<b>TRANSMIT TIME DELAY</b>	Programmable between 0 and 199 ms
<b>DATA</b>	8 bit (1 start bit, 1 or 2 stop bits)
<b>PARITY</b>	Even, Odd, or None with 1 or 2 stop bits
<b>BYTE-TO-BYTE TIMEOUT</b>	0.01 – 2.54 second
<b>TURN AROUND DELAY</b>	Less than 2 ms (fixed)

*Note: Refer to the **PROPLUS** Modbus Register Tables located at [www.yokogawa-usa.com](http://www.yokogawa-usa.com) for details.*

**YPPA1044 Digital Input & Output Expansion Module**

<b>CHANNELS</b>	4 digital inputs & 4 digital outputs per module
<b>SYSTEM</b>	Up to 2 modules for a total of 8 inputs & 8 outputs
<b>DIGITAL INPUT LOGIC HIGH</b>	3 to 5 VDC
<b>DIGITAL INPUT LOGIC LOW</b>	0 to 1.25 VDC
<b>DIGITAL OUTPUT LOGIC HIGH</b>	3.1 to 3.3 VDC
<b>DIGITAL OUTPUT LOGIC LOW</b>	0 to 0.4 VDC
<b>SOURCE CURRENT</b>	10 mA maximum output current
<b>SINK CURRENT</b>	1.5 mA minimum input current
<b>+5 V TERMINAL</b>	To be used as pull-up for digital inputs only Connect normally open pushbuttons across +5 V & DI 1-4.

## COMPLIANCE INFORMATION

### Safety

<b>UL &amp; c-UL LISTED</b>	USA & Canada UL 508 Industrial Control Equipment
<b>UL FILE NUMBER</b>	E348677
<b>FRONT PANEL</b>	UL Type 4X, NEMA 4X, IP65; panel gasket provided
<b>LOW VOLTAGE DIRECTIVE</b>	EN 61010-1:2001 Safety requirements for measurement, control, and laboratory use

### Electromagnetic Compatibility

<b>EMISSIONS</b>	EN 55022:2006/A1:2007 Class A ITE emissions requirements
Radiated Emissions	Class A
AC Mains Conducted Emissions	Class A
<b>IMMUNITY</b>	EN 61326-1:2006 Measurement, control, and laboratory equipment EN 61000-6-2:2005 EMC heavy industrial generic immunity standard
RFI - Amplitude Modulated	80 -1000 MHz 10 V/m 80% AM (1 kHz) 1.4 - 2.0 GHz 3 V/m 80% AM (1 kHz) 2.0 - 2.7 GHz 1 V/m 80% AM (1 kHz)
Electrical Fast Transients	±2kV AC mains, ±1kV other
Electrostatic Discharge	±4kV contact, ±8kV air
RFI - Conducted	10V, 0.15-80 MHz, 1kHz 80% AM
AC Surge	±2kV Common, ±1kV Differential
Surge	1KV (CM)
Power-Frequency Magnetic Field	3 A/m 70%V for 0.5 period
Voltage Dips	40%V for 5 & 50 periods 70%V for 25 periods
Voltage Interruptions	<5%V for 250 periods

**Note:**

Testing was conducted on YPP6200 meters installed through the covers of grounded metal enclosures with cable shields grounded at the point of entry representing installations designed to optimize EMC performance.

*Declaration of Conformity available at [www.yokogawa-usa.com](http://www.yokogawa-usa.com)*

**SAFETY INFORMATION**

**CAUTION:** Read complete instructions prior to installation and operation of the meter.



**WARNING:** Risk of electric shock or personal injury.



**Warning!**

***Hazardous voltages exist within enclosure.  
Installation and service should be performed only by  
trained service personnel.***

## INSTALLATION

There is no need to remove the meter from its case to complete the installation, wiring, and setup of the meter for most applications. Instructions are provided for setting up a 12/24 VDC powered meter to operate from 12 VDC and for changing the transmitter power supply to output 5 or 10 VDC instead of 24 VDC, see page 18.

### Unpacking

Remove the meter from box. Inspect the packaging and contents for damage. Report damages, if any, to the carrier.

If any part is missing or the meter malfunctions, please contact your supplier or the factory for assistance.

### Panel Mounting Instructions

- Prepare a standard 1/8 DIN panel cutout – 3.622" x 1.772" (92 mm x 45 mm). Refer to Figure 1 for more details.
- Clearance: allow at least 6.0" (152 mm) behind the panel for wiring.
- Panel thickness: 0.04" - 0.25" (1.0 mm - 6.4 mm).  
Recommended minimum panel thickness to maintain Type 4X rating: 0.06" (1.5 mm) steel panel, 0.16" (4.1 mm) plastic panel.
- Remove the two mounting brackets provided with the meter (back-off the two screws so that there is  $\frac{1}{4}$ " (6.4 mm) or less through the bracket. Slide the bracket toward the front of the case and remove).
- Insert meter into the panel cutout.
- Install mounting brackets and tighten the screws against the panel. To achieve a proper seal, tighten the mounting bracket screws evenly until meter is snug to the panel along its short side. DO NOT OVER TIGHTEN, as the rear of the panel may be damaged.

**Note:** See Figure 21 on page 103 for 1/8 DIN Panel Cutout Template

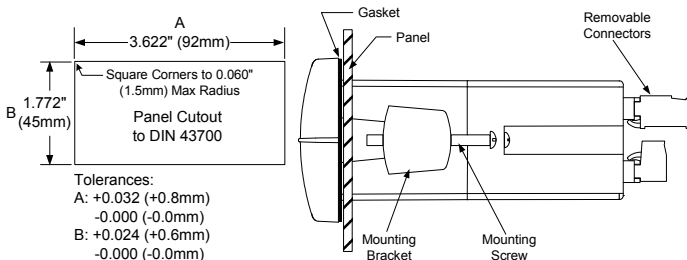

**Figure 1: 1/8 DIN Panel Cutout and Mounting**



**Dimensions**

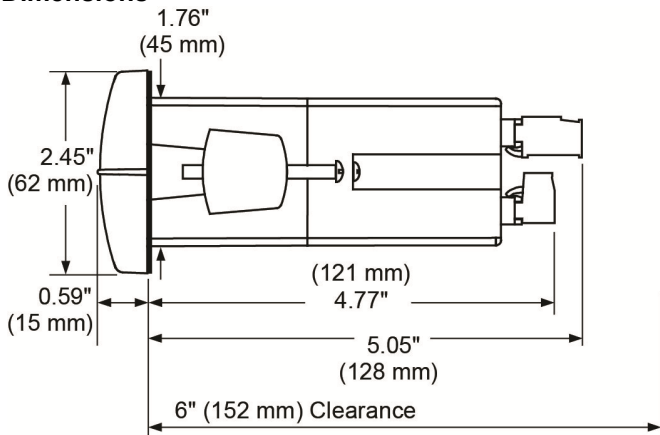

**Figure 2: Meter Dimensions - Side View**

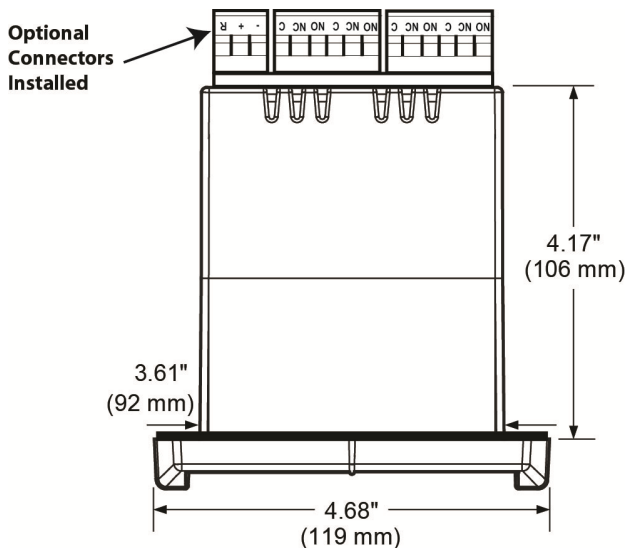

**Figure 3: Meter Dimensions - Top View**

## Configuration for 12 or 24 VDC Power Option



**Warning!**

***Do not exceed voltage rating of the selected configuration.***

Meters equipped with the 12/24 VDC power option are shipped from the factory ready to operate from 24 VDC.

To configure the meter for 12 VDC power:

1. Remove all the connectors.
2. Unscrew the back cover.
3. Slide the back cover about 1 inch.
4. Configure the J9 jumper, located behind the power connector, for 12 V as shown below.

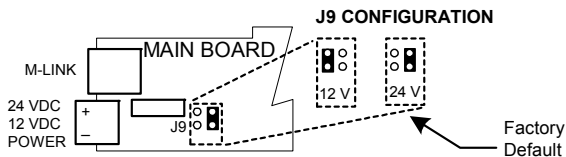

**Figure 4: Jumper Configuration for 12/24 VDC Power**

## Transmitter Supply Voltage Selection (P+, P-)

All meters, including models equipped with the 12/24 VDC power option, are shipped from the factory configured to provide 24 VDC power for the transmitter or sensor.

If the transmitter requires 5 or 10 VDC excitation, the internal jumper J4 must be configured accordingly.

To access the voltage selection jumper:

1. Remove all the connectors.
2. Unscrew the back cover.
3. Slide the back cover about 1 inch.
4. Configure the J4 jumper, located behind the input signal connector, for the desired excitation voltage as shown.

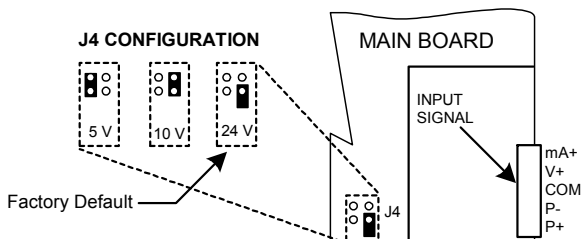

**Figure 5: Transmitter Supply Voltage Selection**

## Connections

All connections are made to removable screw terminal connectors located at the rear of the meter.



### Caution!

Use copper wire with 60°C or 60/75°C insulation for all line voltage connections. Observe all safety regulations. Electrical wiring should be performed in accordance with all applicable national, state, and local codes to prevent damage to the meter and ensure personnel safety.

## Connectors Labeling

The connectors' label, affixed to the meter, shows the location of all connectors available with requested configuration.



**Warning!**

***Do not connect any equipment other than Yokogawa's expansion modules, cables, or meters to the RJ45 M-LINK connector. Otherwise damage will occur to the equipment and the meter.***

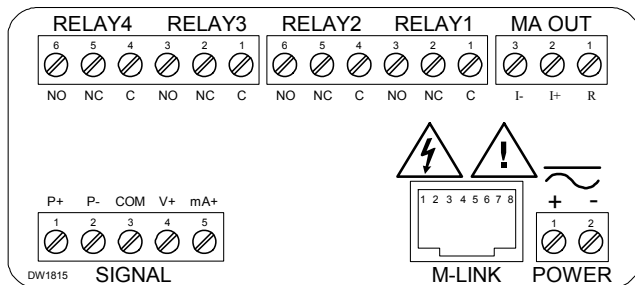

**Figure 6: Connector Labeling for Fully Loaded YPP6200**

## Power Connections

Power connections are made to a two-terminal connector labeled POWER on Figure 6. The meter will operate regardless of DC polarity connection. The + and - symbols are only a suggested wiring convention.

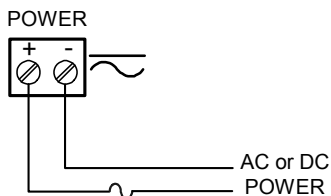

Required External Fuse:  
5 A max, 250 V Slow Blow

**Figure 7: Power Connections**

## Signal Connections

Signal connections are made to a five-terminal connector labeled SIGNAL on Figure 6. The COM (common) terminal is the return for the 4-20 mA and the  $\pm 10$  V input signals.

### Current and Voltage Connections

The following figures show examples of current and voltage connections. There are no switches or jumpers to set up for current and voltage inputs. Setup and programming is performed through the front panel buttons.

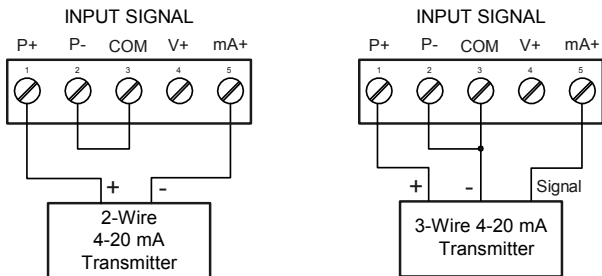

**Figure 8: Transmitters Powered by Internal Supply**

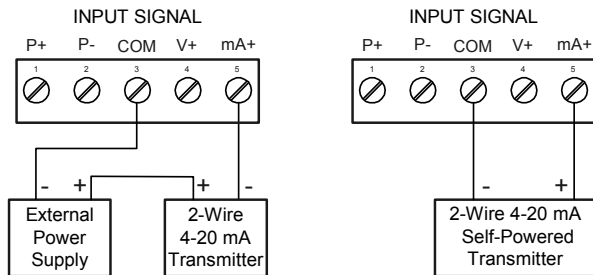

**Figure 9: Transmitter Powered by Ext. Supply or Self-Powered**

The current input is protected against current overload by a resettable fuse. The display may or may not show a fault condition depending on the nature of the overload.

The fuse limits the current to a safe level when it detects a fault condition, and automatically resets itself when the fault condition is removed.

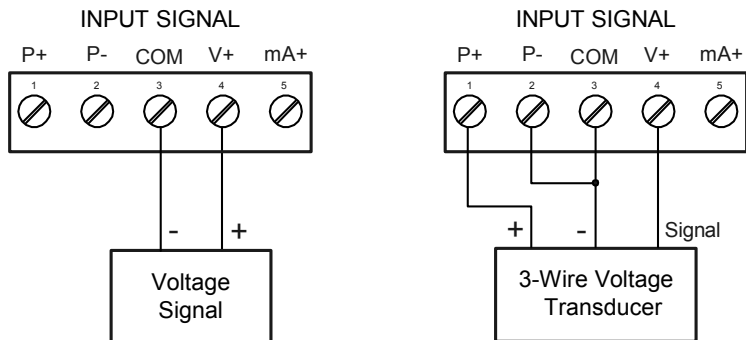

**Figure 10: Voltage Input Connections**

The meter is capable of accepting any voltage from -10 VDC to +10 VDC.

### Modbus RTU Serial Communications

Serial communications connection is made to an RJ45 connector labeled M-LINK on Figure 6. For interfacing to the **PROPLUS** use the YPPA1232 for RS-232, the YPPA1485 for RS-485, or the YPPA8008 for USB. The same port is used for interfacing with all expansion modules (e.g. external relays, digital I/O).

Use the YPPA1200 meter copy cable for meter-to-meter interfacing for cloning purposes (i.e. copying settings from one meter to other meters).

### Relay Connections

Relay connections are made to two six-terminal connectors labeled RELAY1 – RELAY4 on Figure 6. Each relay's C terminal is common only to the normally open (NO) and normally closed (NC) contacts of the corresponding relay. The relays' C terminals should not be confused with the COM (common) terminal of the INPUT SIGNAL connector.

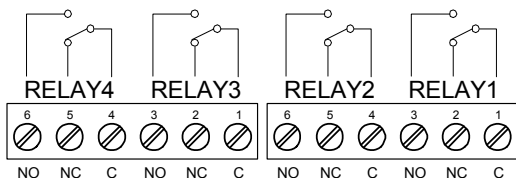

**Figure 11: Relay Connections**

## Switching Inductive Loads

The use of suppressors (snubbers) is strongly recommended when switching inductive loads to prevent disrupting the microprocessor's operation. The suppressors also prolong the life of the relay contacts. Suppression can be obtained with resistor-capacitor (RC) networks assembled by the user or purchased as complete assemblies. Refer to the following circuits for RC network assembly and installation:

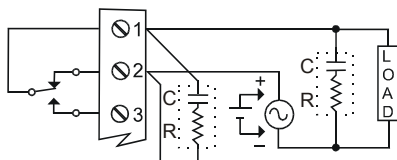

**Figure 12: AC and DC Loads Protection**

Choose R and C as follows:

R: 0.5 to 1  $\Omega$  for each volt across the contacts

C: 0.5 to 1  $\mu\text{F}$  for each amp through closed contacts

### Notes:

1. Use capacitors rated for 250 VAC.
2. RC networks may affect load release time of solenoid loads. Check to confirm proper operation.
3. Install the RC network at the meter's relay screw terminals. An RC network may also be installed across the load. Experiment for best results.

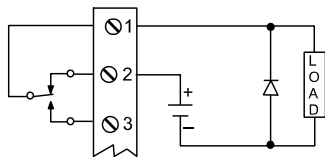

Use a diode with a reverse breakdown voltage two to three times the circuit voltage and forward current at least as large as the load current.

**Figure 13: Low Voltage DC Loads Protection**

**Note:** Relays are de-rated to 1/14th HP (50 watts) with an inductive load.

### 4-20 mA Output Connections

Connections for the 4-20 mA transmitter output are made to the connector terminals labeled MA OUT. The 4-20 mA output may be powered internally or from an external power supply.

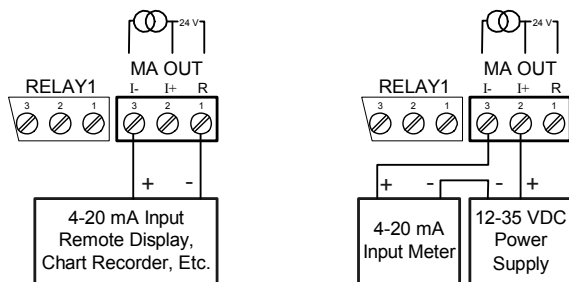

Figure 14: 4-20 mA Output Connections

### Analog Output Transmitter Power Supply

The internal 24 VDC power supply powering the analog output may be used to power other devices, if the analog output is not used. The I+ terminal is the +24 V and the R terminal is the return. This power supply is capable of sourcing up to 40 mA.



## External Relay & Digital I/O Connections

The relay and the digital I/O expansion modules YPPA1004 & YPPA1044 are connected to the meter using a CAT5 cable provided with each module. The two RJ45 connectors on the expansion modules are identical and interchangeable; they are used to connect additional modules to the system.

*Note: The jumper located between the RJ45 connectors of the YPPA1044 must be removed on the second digital I/O module in order for the system to recognize it as module #2.*



**Warning!**

***Do not connect or disconnect the expansion modules with the power on!***

***More detailed instructions are provided with each optional expansion module.***

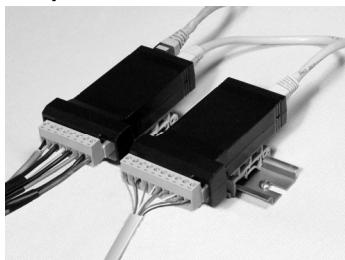

**Figure 15: Expansion Modules & DIN Rail Mounting Kit**

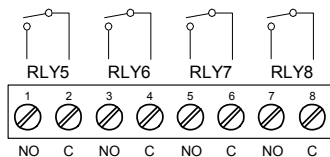

**Figure 16: External Relays Module Connections**

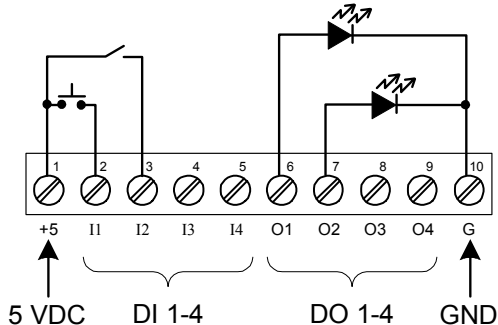

Figure 17: Digital I/O Module Connections

### Interlock Relay Feature

As the name implies, the interlock relay feature reassigns one, or more, alarm/control relays for use as interlock relay(s). Interlock contact(s) are wired to digital input(s) and trigger the interlock relay. This feature is enabled by configuring the relay, and relative digital input(s) (see page 66). In one example, dry interlock contacts are connected in series to one digital input which will be used to force on (energize) the assigned interlock power relay when all interlock contacts are closed (safe). The interlock relay front panel LED flashes when locked out. The interlock relay would be wired in-series with the load (N/O contact). See below.

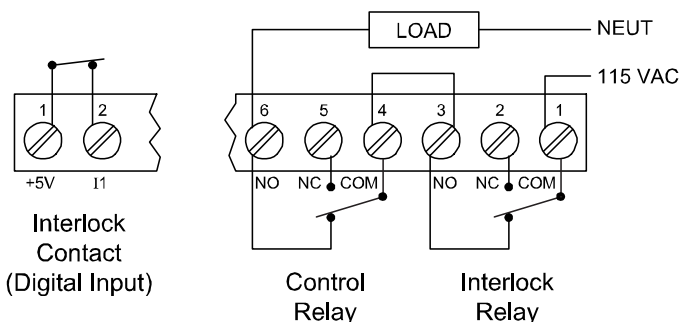

Figure 18. Interlock Connection

## SETUP AND PROGRAMMING

The meter is factory calibrated prior to shipment to read in milliamps and volts depending on the input selection. The calibration equipment is certified to NIST standards.

### Overview





There are no jumpers to set for the meter input selection.

Setup and programming is done through the front panel buttons.

After power and input signal connections have been completed and verified, apply power to the meter.

## Front Panel Buttons and Status LED Indicators



Button Symbol	Description
	Menu
	Right arrow/F1
	Up arrow/F2
	Enter/F3
<p><i>Note:</i> Alarms 5-8 are enabled when relay expansion module is installed.</p>	

LED	Status
1-8	Alarm 1 – 8 indicator
R	Rate indicator
T	Total indicator or Flashing: Tare
G T	Grand Total indicator
▲	Total overflow indicator
M	Manual control relays &/or analog output

- Press the Menu button to enter or exit the Programming Mode at any time.
- Press the Right arrow button to move to the next digit during digit or decimal point programming.
- Press or hold the Up arrow button to scroll through the menus, decimal point, or to increment the value of a digit.
- Press the Enter button to access a menu or to accept a setting.
- Press and hold the Menu button for three seconds to access the advanced features of the meter.

## Display Functions and Messages

The meter displays various functions and messages during setup, programming, and operation. The following table shows the main menu functions and messages in the order they appear in the menu.

Display	Parameter	Action/Setting Description
rESEt	<i>Reset</i>	Press Enter to access the <i>Reset</i> menu
rSt t	<i>Reset total</i>	Press Enter to reset total
rSt Gt	<i>Reset grand total</i>	Press Enter to reset grand total
rSt Hi	<i>Reset high</i>	Press Enter to reset max display
rSt Lo	<i>Reset low</i>	Press Enter to reset min display
rSt HL	<i>Reset high &amp; low</i>	Press Enter to reset max & min displays
CoNtRl	<i>Control</i>	Enter <i>Control</i> menu
Auto	<i>Automatic</i>	Press Enter to set meter for automatic operation
MAN	<i>Manual</i>	Press Enter to manually control relays or analog output operation
SEtUP	<i>Setup</i>	Enter <i>Setup</i> menu
INPut	<i>Input</i>	Enter <i>Input</i> selection menu
mA	<i>4-20 mA</i>	Set meter for 4-20 mA input
VDC	<i>0-10 VDC</i>	Set meter for $\pm 10$ VDC input
toTAL	<i>Total</i>	Enable or disable totalizer features
LEvEL	<i>Level</i>	Enter <i>Level</i> menu and select <i>Yes</i> for dual-scale display or <i>No</i> for single scale display
dEc Pt	<i>Decimal point</i>	Set decimal point for rate, total, grand total
PrOG	<i>Program</i>	Enter the <i>Program</i> menu
SCALe	<i>Scale</i>	Enter the <i>Scale</i> menu
CRl	<i>Calibrate</i>	Enter the <i>Calibrate</i> menu
INP 1	<i>Input 1</i>	Calibrate input 1 signal or program input 1 value
dIS 1	<i>Display 1</i>	Program display 1 value
INP 2	<i>Input 2</i>	Calibrate input 2 signal or program input 2

Display	Parameter	Action/Setting Description
		value (up to 32 points)
d 1 2	Display 2	Program display 2 value (up to 32 points)
Error	Error	Error, calibration not successful, check signal or programmed value
dSPRAY	Display	Enter the <i>Display</i> menu
b 0	Big display	Press Enter to assign the Main display parameter (default: PV or rate)
L t t t E	Little display	Press Enter to assign the small display parameter (default: total)
d- IntY	Display intensity	Set display intensity level from 1 to 8
rELAY	Relay	Enter the <i>Relay</i> menu
RSS 0n	Assignment	Assign relays to rate, total, or grand total
RS 0n 1	Assign 1	Relay 1 assignment
rRATE	Rate	Assign relay to rate
t o t a l	Total	Assign relay to total
G t o t a l	Grand total	Assign relay to grand total
rLY 1	Relay 1	Relay 1 setup
Rct 1	Action 1	Set relay 1 action
Ru to	Automatic	Set relay for automatic reset
R-nRn	Auto-manual	Set relay for automatic & manual reset any time
LRtEH	Latching	Set relay for latching operation (relays assigned to rate)
Lt-Clr	Latching-cleared	Set relay for latching operation with manual reset only after alarm condition has cleared (relays assigned to rate)
RLtErn	Alternate	Set relay for pump alternation control (relays assigned to rate)
SRnPL	Sampling	Set relay for sampling operation
OFF	Off	Disable relay and front panel status LED (Select Off to enable Interlock feature)
SEt 1	Set 1	Program set point 1
rSEt 1	Reset 1	Program reset point 1

Display	Parameter	Action/Setting Description
rLY 2	Relay 2	Relays 2-8 setup <i>Note: Relays 5-8 are shown, only if expansion relay module is installed.</i>
FR dLF	Fail-safe	Enter Fail-safe menu
FLS 1	Fail-safe 1	Set relay 1 fail-safe operation
On	On	Enable fail-safe operation
OFF	Fail-safe off	Disable fail-safe operation
dELRY	Delay	Enter relay Time Delay menu
dLY 1	Delay 1	Enter relay 1 time delay setup
On 1	On	Set relay 1 On time delay
OFF 1	Off	Set relay 1 Off time delay
brERH	Loop break	Set relay condition if loop break detected (For mA input only)
IgnoreE	Ignore	Ignore loop break condition (Processed as a low signal condition)
On	On	Relay goes to alarm condition when loop break is detected
OFF	Off	Relay goes to non-alarm condition when loop break is detected
Rout	Analog output	Enter the Analog output scaling menu
dIS 1	Display 1	Program display 1 value
Out 1	Output 1	Program output 1 value (e.g. 4.000 mA)
dIS 2	Display 2	Program display 2 value
Out 2	Output 2	Program output 2 value (e.g. 20.000 mA)
t tb	Total time base	Program total time base
t CF	Total conversion factor	Program total conversion factor
t rSt	Total reset	Program total rest mode: auto or manual
Gt tb	Grand total time base	Program grand total time base
Gt CF	Grand total conversion factor	Program grand total conversion factor

Display	Parameter	Action/Setting Description
ᄂᄂ ᄂᄂᄂ	<i>Grand total reset</i>	Program grand total rest mode: auto or manual
<i>Auto</i>	<i>Automatic</i>	Press Enter to set automatic total reset
<i>ᄂ ᄂᄂᄂ</i>	<i>Time delay</i>	Program time delay for total auto reset
<i>ᄂᄂ ᄂᄂ</i>	<i>Manual</i>	Press Enter to reset total manually
<i>PR55</i>	<i>Password</i>	Enter the <i>Password</i> menu
<i>PR55 1</i>	<i>Password 1</i>	Set or enter Password 1
<i>PR55 2</i>	<i>Password 2</i>	Set or enter Password 2
<i>PR55 3</i>	<i>Password 3</i>	Set or enter Password 3
<i>ᄂᄂᄂᄂ</i>	<i>Total password</i>	Set or enter password for manual reset
<i>ᄂᄂᄂᄂᄂ</i>	<i>Grand total password</i>	Set or enter password for manual reset
<i>ᄂᄂᄂᄂᄂ</i>	<i>Non-resettable</i>	Non-resettable grand total set after entering "050873" for Gtotal password
<i>ᄂᄂᄂᄂ</i>	<i>Unlocked</i>	Program password to lock meter
<i>ᄂᄂᄂᄂ</i>	<i>Locked</i>	Enter password to unlock meter
<i>999999</i> <i>-999999</i>	<i>Flashing display</i>	Overrange condition Underrange condition



## Main Menu

The main menu consists of the most commonly used functions: *Reset*, *Control*, *Setup*, and *Password*.

- Press Menu button to enter Programming Mode then press the Up arrow button to scroll main menu.

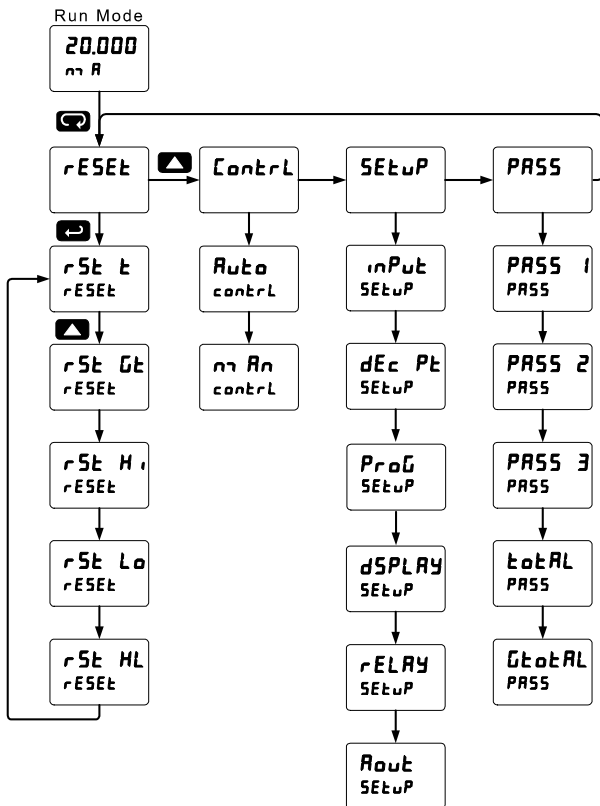

- Press Menu, at any time, to exit and return to Run Mode. Changes made to settings prior to pressing Enter are not saved.
- Changes to the settings are saved to memory only after pressing Enter.
- The display moves to the next menu every time a setting is accepted by pressing Enter.

### Setting Numeric Values

The numeric values are set using the Right and Up arrow buttons. Press Right arrow to select next digit and Up arrow to increment digit value.

The digit being changed is displayed brighter than the rest.

Press and hold up arrow to auto-increment the display value.

Press the Enter button, at any time, to accept a setting or Menu button to exit without saving changes.

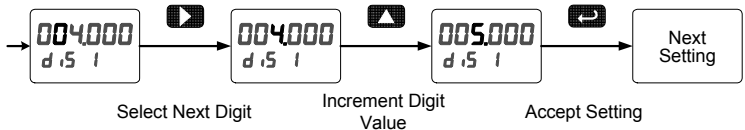

### Reset Menu (rESEt)

The *Reset* menu is used to reset the totals, maximum or minimum reading (peak or valley) reached by the process; both may be reset at the same time by selecting “reset high & low” (rSEt HL).

### Control Menu (ContrL)

The *Control* menu is used to control the 4-20 mA analog output and the relays manually, ignoring the input. Each relay and analog output can be programmed independently for manual control. Selecting automatic control sets all relays and analog output for automatic operation.

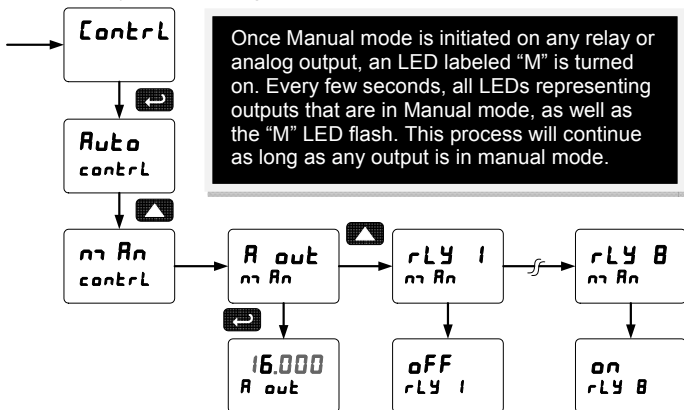

## Setting Up the Rate/Totalizer Meter (SETUP)

The Setup menu is used to select:

1. Input signal the meter will accept
2. Enable or disable totalizer features
3. Decimal point position
4. Display parameter and intensity
5. Relay operation
6. 4-20 mA analog output scaling

Press the Enter button to access any menu or press Up arrow button to scroll through choices. Press the Menu button to exit at any time.

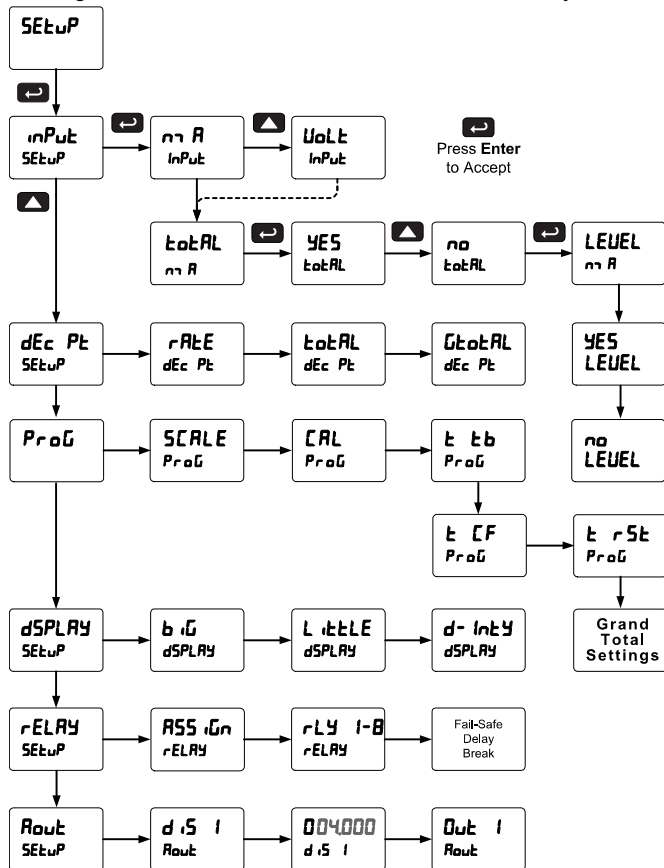

### Setting the Input Signal ( $mP_{UL}$ )

Enter the *Input* menu to set up the meter to display current ( $mA$ ) or voltage ( $VDC$ ) inputs.

The current input is capable of accepting any signal from 0 to 20 mA. Select current input to accept 0-20 mA or 4-20 mA signals.

The voltage input is capable of accepting any signal from -10 to +10 VDC. Select voltage input to accept 0-5, 1-5, 0-10, or  $\pm 10$  VDC signals.

### Setting the Totalizer Features ( $t_{UL}$ )

Enable or disable the totalizer features by selecting “ $YES$ ” or “ $no$ ” after the input type has been set up. If the totalizer features are disabled, all the totalizer features and functions are hidden from the menus.

Notes:

1. *The totalizer continues working in the background.*
2. *When selecting “no” for Total, the meter now functions as a YPP6000 Process Meter. We strongly suggest that you download and use the YPP6000 instruction manual from our website ([www.yokogawa-usa.com](http://www.yokogawa-usa.com)) while in this mode of operation.*

### Dual-Scale for Level Application

The analog input can be displayed in two different scales, by enabling the dual-scale feature (LEVEL) in the *Setup Input* menu, see page 36. To enable the dual-scale feature for level applications you must select LEVEL in the Input selection menu.

#### Scaling the Input for PV1 (SCAL 1)

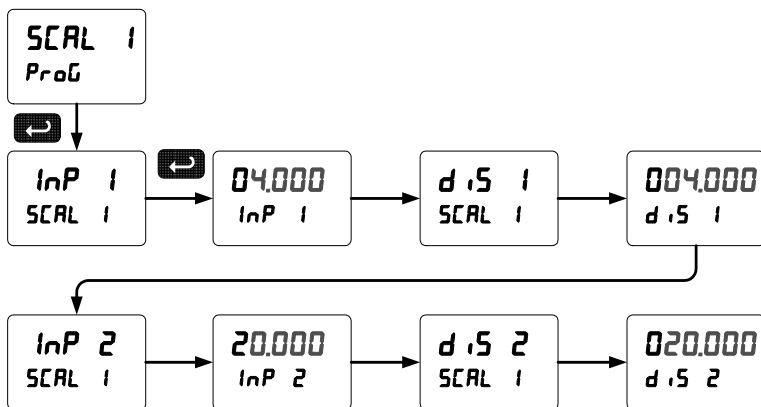

#### Scaling the Input for PV2 (SCAL 2)

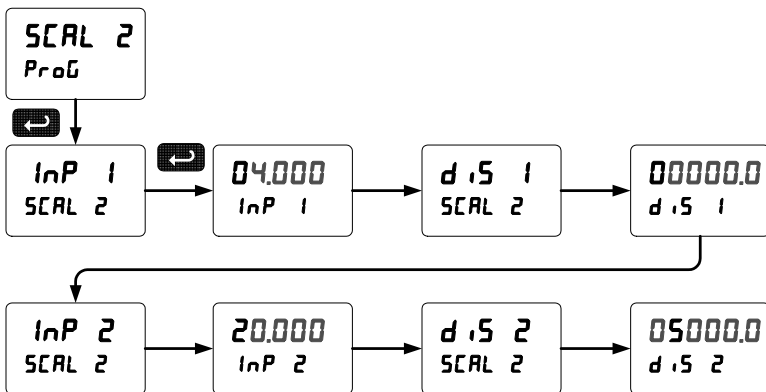

## Setting the Decimal Point (*dEc Pt*)

The decimal point may be set with up to five decimal places or with no decimal point at all. The rate, total, and grand total decimal points are independent.

Pressing the Right arrow moves the decimal point one place to the right until no decimal point is displayed then it moves to the leftmost position.

## Programming the Rate/Totalizer (*Prog*)

It is **very important** to read the following information, before proceeding to program the meter:

- The meter is factory calibrated prior to shipment to read in milliamps and volts depending on the input selection. The calibration equipment is certified to NIST standards.
- Use the *Scale* menu to scale process inputs (e.g. 4-20 mA). A calibrated signal source is not needed to scale the meter.
- Use the *Calibrate* menu to apply a signal from a calibrator or a flowmeter.

The *Program* menu contains the following menus:

1. Scale without a signal source
2. Calibrate with a calibrated signal source
3. Total time base & conversion factor
4. Grand total time base & conversion factor
5. Total reset mode for total & grand total

**Note:** The *Scale* and *Calibrate* functions are exclusive of each other. The meter uses the last function programmed. Only one of these methods can be employed at a time. The *Scale* and *Calibrate* functions can use up to 32 points (default is 2). The number of points should be set in the Advanced menu under the Multi-Point Linearization (*Linear*) menu selection prior to scaling and calibration of the meter, see page 78 for details.

The process inputs may be calibrated or scaled to any display value within the range of the meter.

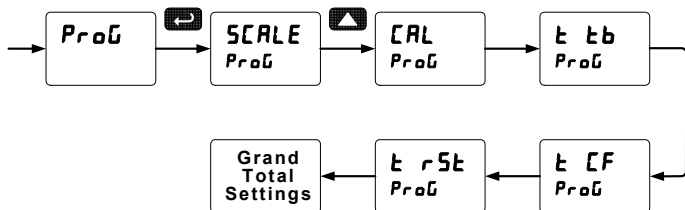

Additional parameters, not needed for most applications, are programmed in the *Advanced Features* menu; see *Advanced Features Menu*, page 71.

### Multi-Point Calibration & Scaling

The meter is set up at the factory for 2-point linear calibration. The number of points for multi-point calibration/scaling is set up in the *Advanced Features* menu. Up to 32 linearization points may be selected. See page 78 for details.

### PROPLUS Software

The meter can also be programmed using the PC-based **PROPLUS** software available for free download at [www.yokogawa-usa.com](http://www.yokogawa-usa.com). Data logging for one meter at the time is available with **PROPLUS** software. More advanced data acquisition may be accomplished by using any Modbus RTU compliant software.

In order to program the meter using a computer, the meter must be connected using a USB, RS-232 or RS-485 serial adapter, see ORDERING INFORMATION on page 7 for details.

### Scaling the Meter (SCALE)

The process inputs (4-20 mA and  $\pm 10$  VDC) can be scaled to display the process variable in engineering units.

A signal source is not needed to scale the meter; simply program the inputs and corresponding display values.

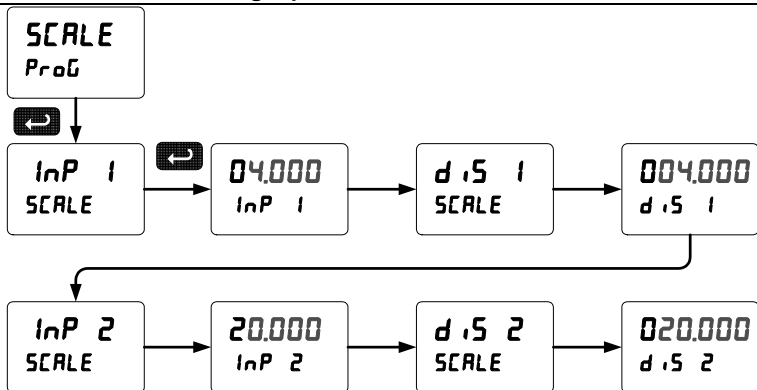

For instructions on how to program numeric values see *Setting Numeric Values*, page 34.



### Error Message (Error)

An error message indicates that the calibration or scaling process was not successful.

After the error message is displayed, the meter reverts to input 2 during calibration or scaling and to input 1 during internal calibration, allowing the appropriate input signal to be applied or programmed.

The error message might be caused by any of the following conditions:

1. Input signal is not connected to the proper terminals or it is connected backwards.
2. Wrong signal selection in *Setup* menu.
3. Minimum input span requirements not maintained.
4. Input 1 signal inadvertently applied to calibrate input 2.

### Minimum Input Span

The minimum input span is the minimum difference between input 1 and input 2 signals required to complete the calibration or scaling of the meter.

Input range	Input 1 & input 2 span
4-20 mA	0.15 mA
±10 VDC	0.10 VDC

The time base, total conversion factor, and total reset menus are located in the *Program* menu.

The total and grand total have their own independent settings. This means that one can be displaying the value in gallons while the other displays in million gallons, liters, m<sup>3</sup>, etc.

### Total & Grand Total Reset

The totals can be programmed for manual or automatic reset. In the automatic reset mode, a programmable time delay is available to reset the total or grand total after the assigned preset is reached.

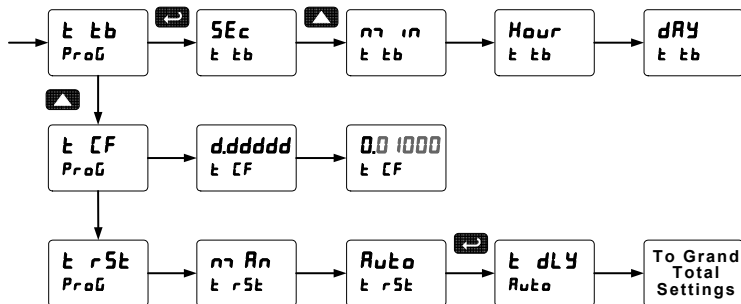

### Non-Resettable Totalizer

The total and grand total can be password-protected to prevent unauthorized resets. The grand total can be programmed as a non-resettable total, see page 69 for details.

To scale the meter without a signal source refer to Scaling the Meter (SCALE) page 39.

The meter can be calibrated to display the process variable in engineering units by applying the appropriate input signal and following the calibration procedure.

The use of a calibrated signal source is strongly recommended to calibrate the meter.

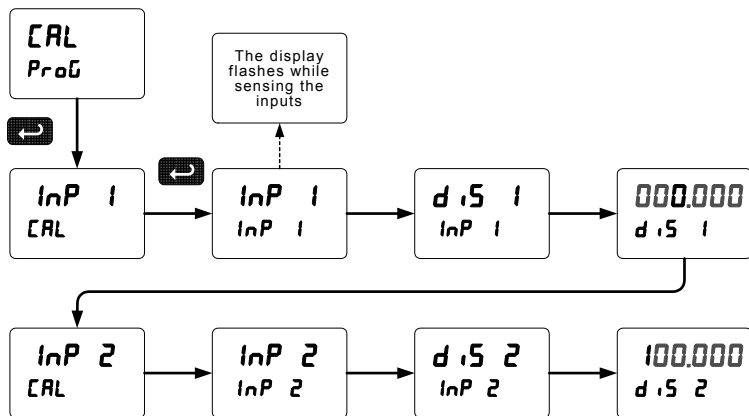

*Warm up the meter for at least 15 minutes before performing calibration to ensure specified accuracy.*

## Setting the Display Parameter & Intensity (dSPRAY)

The main display (b ũ) can be programmed to display:

1. Rate value
2. Total or grand total
3. Relay set points
4. Max & min values
5. Modbus input
6. Display rate and units

The small display (L ũũũũũ) can be programmed to display:

1. Rate value
2. Total or grand total
3. Relay set points
4. Max & min values
5. Engineering units or custom legends
6. Modbus input
7. Off (no display)
8. Display rate and units

Display Intensity: The meter has eight display intensity levels to give the best performance under various lighting conditions. Select intensity 8 for outdoor applications.

Display Setup Menu

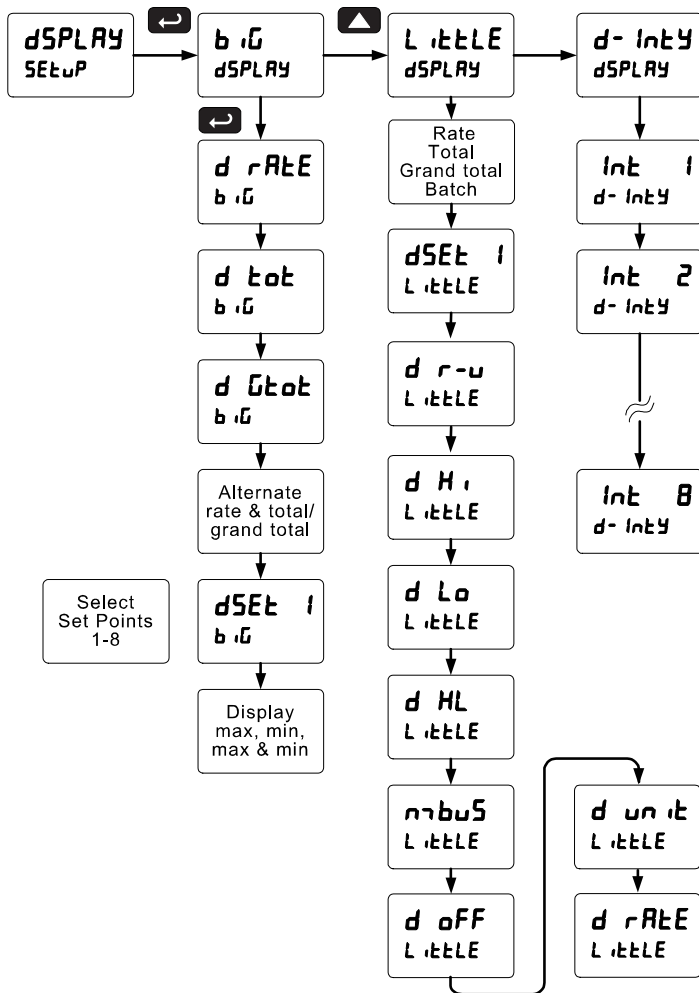

After setting up the input and the display, press the Menu button to exit programming and skip the rest of the setup menu. Press the Menu button again and the Up arrow to reach the *Program* menu and complete the scaling or calibration of the meter.

### Character Set for Engineering Units Display (d u n t)

The small display can be programmed to show engineering units or custom legends using the following 7-segment character set:

Display	Character
0	0
1	1
2	2
3	3
4	4
5	5
6	6
7	7
8	8
9	9
A	A
b	b
C	C
c	c
d	d
E	E
F	F
G	G
g	g
H	H
h	h
I	I
i	i
J	J

Display	Character
K	K
L	L
m	m
n	n
O	O
o	o
P	P
q	q
r	r
S	S
t	t
u	u
V	V
w	w
X	X
Y	Y
Z	Z
-	-
/	/
]	]
[	[
=	=
	Space
°	Degree

\*Degree symbol (special non-ASCII character used)

The letters "m" and "w" use two 7-segment LEDs each; when selected the characters to the right are shifted one position.

See the flow chart on page 44 to access the display units menu.

Press and hold up arrow to auto-scroll the characters in the display.

## Setting the Relay Operation (RELAY)

This menu is used to set up the operation of the relays.

**CAUTION!** *During setup, the relays do not follow the input and they will remain in the state found prior to entering the Relay menu.*

1. Relay assignment
  - a. Rate for low and high alarm
  - b. Total
  - c. Grand total
2. Relay action
  - a. Automatic reset only (non-latching)
  - b. Automatic + manual reset at any time (non-latching)
  - c. Latching (manual reset only)
  - d. Latching with Clear (manual reset only after alarm condition has cleared)
  - e. Pump alternation control (automatic reset only)
  - f. Sampling (the relay is activated for a user-specified time)
  - g. Off (relay state controlled by Interlock feature)
3. Set and reset points
4. Fail-safe operation
  - a. On (enabled)
  - b. Off (disabled)
5. Time delay
  - a. On delay (0-999.9 seconds)
  - b. Off delay (0-999.9 seconds)
6. Relay action for loss (break) of 4-20 mA input (ignore, on, off)

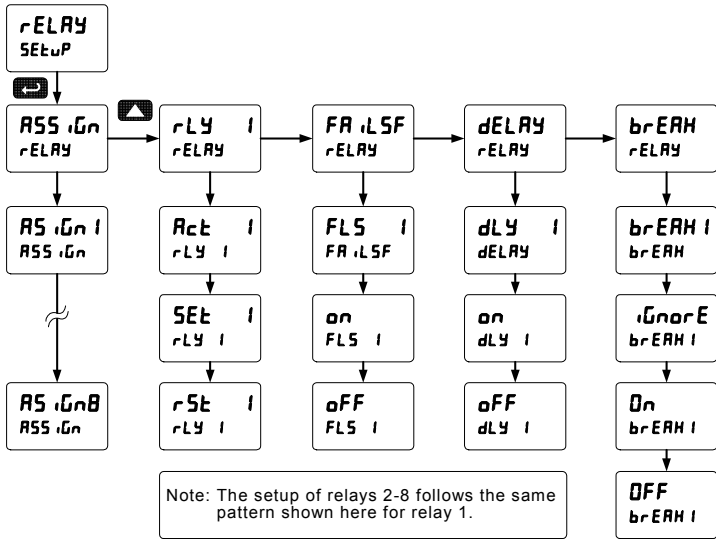

### Relay Assignment (ASS iGn)

The relays can be assigned to any of the following parameters:

1. Rate for low or high alarm indication
2. Total for alarm indication
3. Grand total for alarm indication

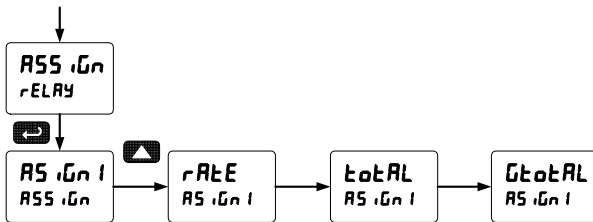



## Setting the Relay Action

Operation of the relays is programmed in the *Action* menu. The relays may be set up for any of the following modes of operation:

1. Automatic reset (non-latching)
2. Automatic + manual reset at any time (non-latching)
3. Latching (manual reset only, at any time)
4. Latching with Clear (manual reset only after alarm condition has cleared)
5. Pump alternation control (automatic reset only)
6. Sampling (the relay is activated for a user-specified time)
7. Off (relay state controlled by Interlock feature)

The following graphic shows relay 1 action setup; relay 2-8 are set up in a similar fashion.

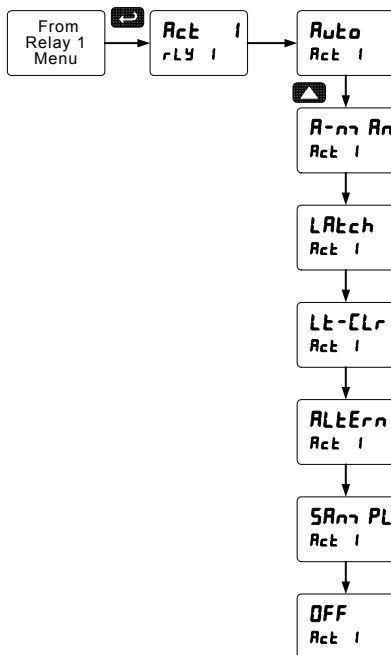

## Programming Set and Reset Points

High alarm indication: program set point above reset point.

Low alarm indication: program set point below reset point.

The deadband is determined by the difference between set and reset points. Minimum deadband is one display count. If the set and reset points are programmed with the same value, the relay will reset one count below the set point.

*Note: Changes are not saved until the reset point has been accepted.*

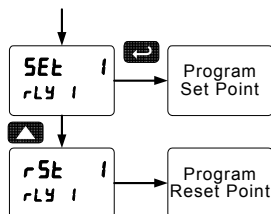

## Setting Fail-Safe Operation

In fail-safe mode of operation, the relay coil is energized when the process variable is within safe limits and the relay coil is de-energized when the alarm condition exists. The fail-safe operation is set independently for each relay. Select **on** to enable or select **oFF** to disable fail-safe operation.

## Programming Time Delay

The *On* and *Off* time delays may be programmed for each relay between 0 and 999.9 seconds. The relays will transfer only after the condition has been maintained for the corresponding time delay.

The *On* time delay is associated with the set point.

The *Off* time delay is associated with the reset point.

## Relay Action for Loss of 4-20 mA Input (Loop Break)

The loop break feature is associated with the 4-20 mA input. Each relay may be programmed to go to one of the following conditions when the meter detects the loss of the input signal (i.e. < 0.005 mA):

1. Turn *On* (Go to alarm condition)
2. Turn *Off* (Go to non-alarm condition)
3. Ignore (Process as a low signal condition)

*Note: This is not a true loop break condition; if the signal drops below 0.005 mA, it is interpreted as a "loop break" condition.*

## Relay and Alarm Operation Diagrams

The following graphs illustrate the operation of the relays, status LEDs, and ACK button.

### High Alarm Operation (Set > Reset)

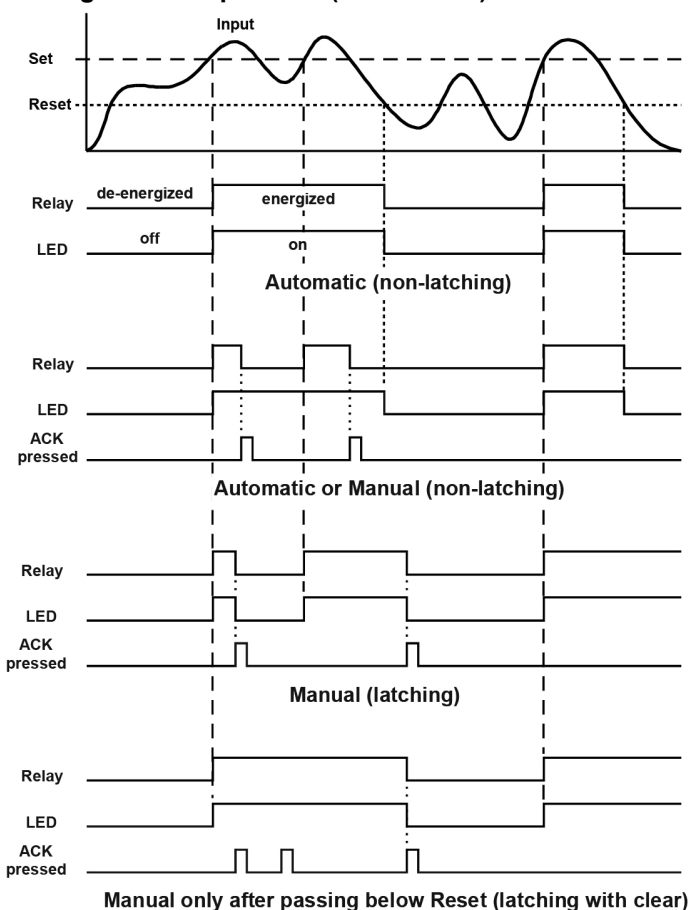

For Manual reset mode, ACK can be pressed anytime to turn "off" relay. To detect a new alarm condition, the signal must go below the set point, and then go above it.

### Low Alarm Operation (Set < Reset)

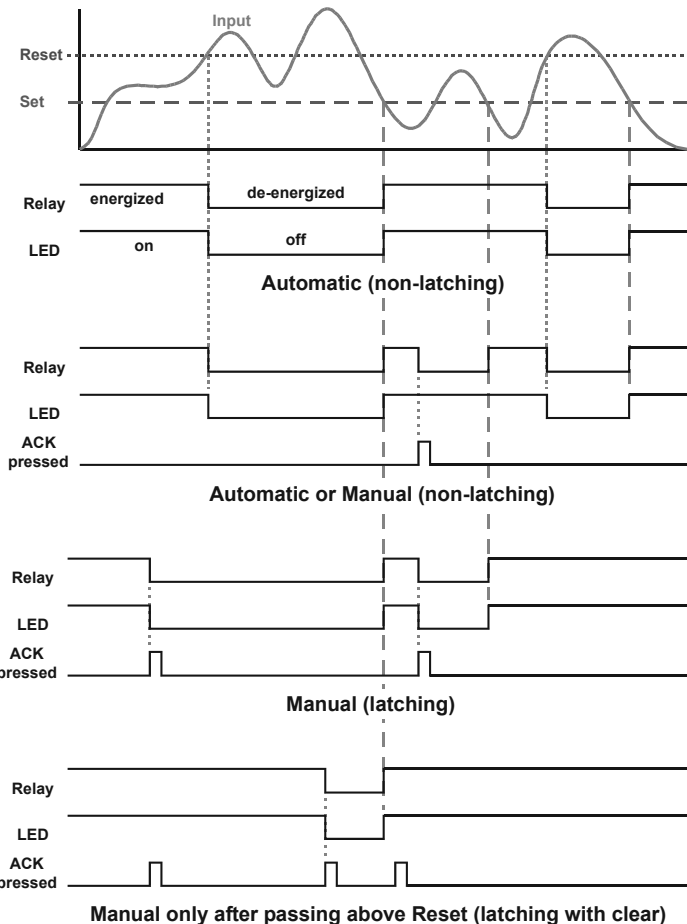

For Manual reset mode, ACK can be pressed anytime to turn "off" relay. For relay to turn back "on", signal must go above set point and then go below it.

### High Alarm with Fail-Safe Operation (Set > Reset)

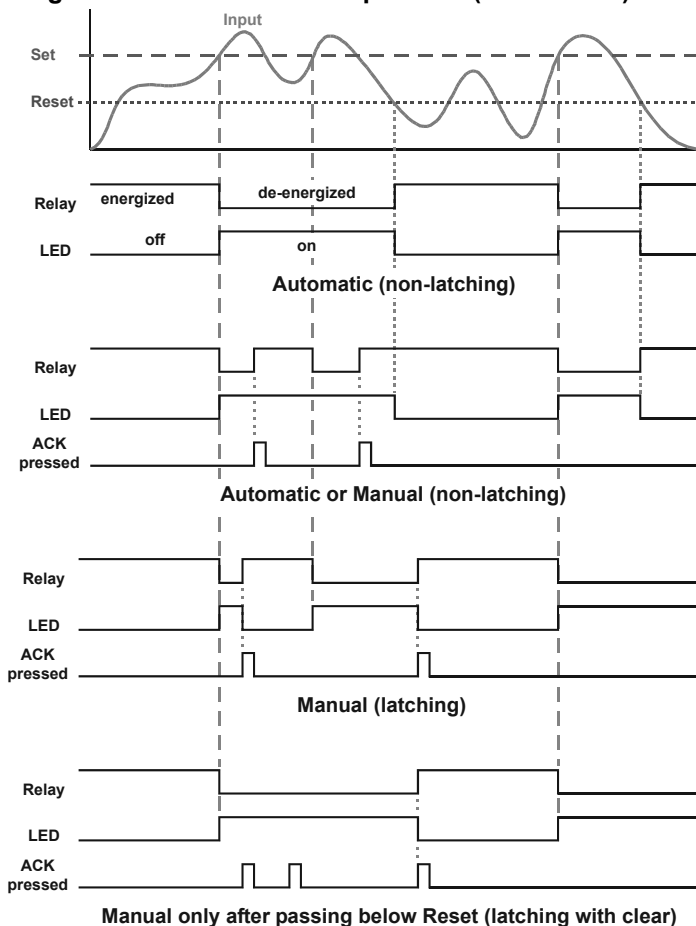

*Note: Relay coil is energized in non-alarm condition.  
In case of power failure, relay will go to alarm state.*

### Low Alarm with Fail-Safe Operation (Set < Reset)

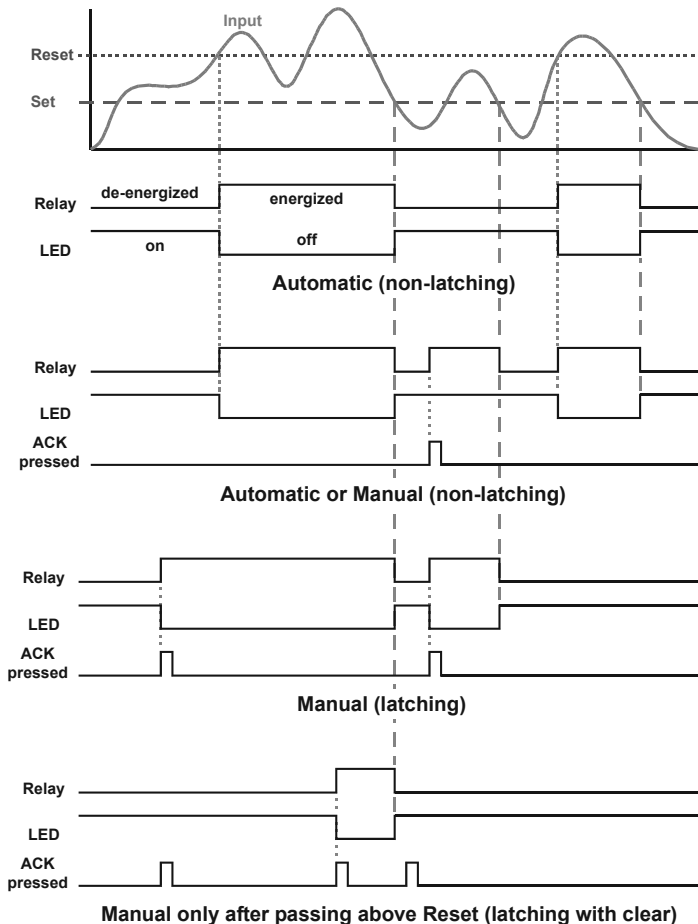

*Note: Relay coil is energized in non-alarm condition.  
In case of power failure, relay will go to alarm state.*

## Pump Alternation Control Operation

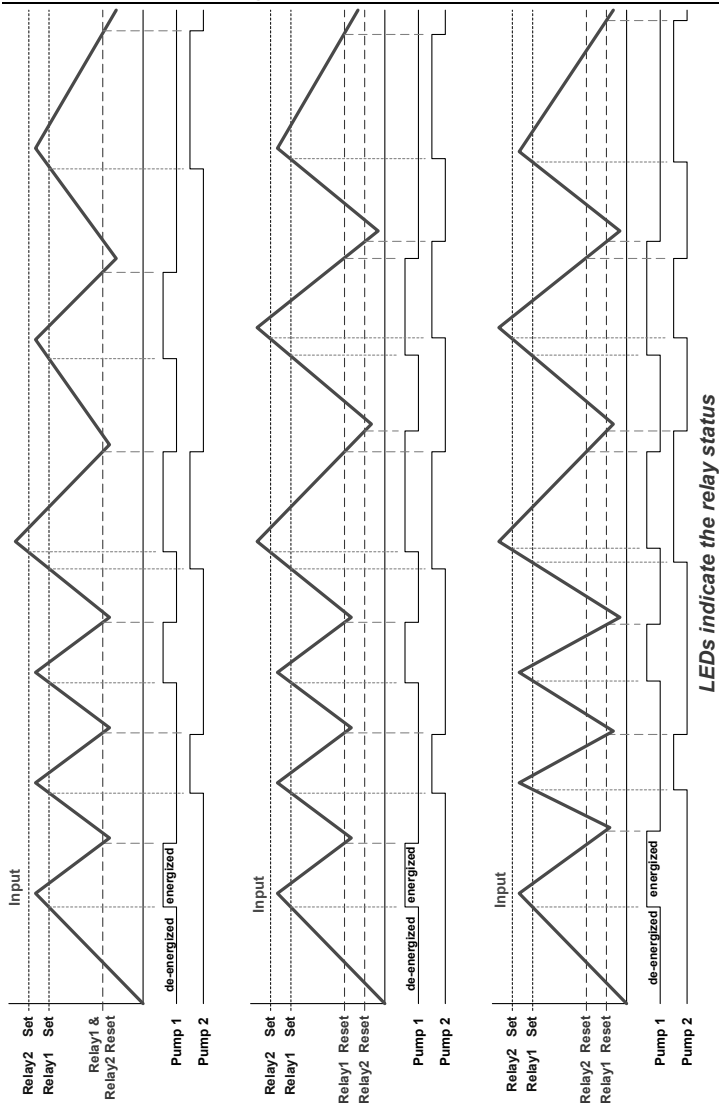

## Rate Relay Sampling Operation

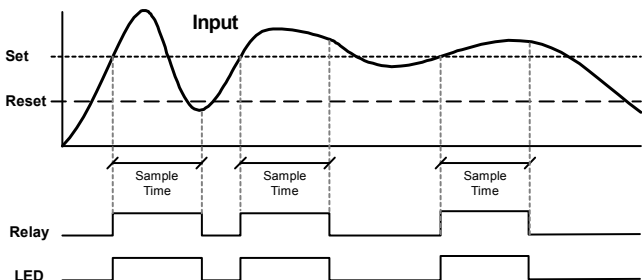

When the signal crosses the set point, the relay trips and the sample time starts. After the sample time has elapsed, the relay resets. The cycle repeats every time the set point is crossed, going up for high alarms and going down for low alarms.

The sample time can be programmed between 0.1 and 5999.9 seconds.

## Total Relay Sampling Operation

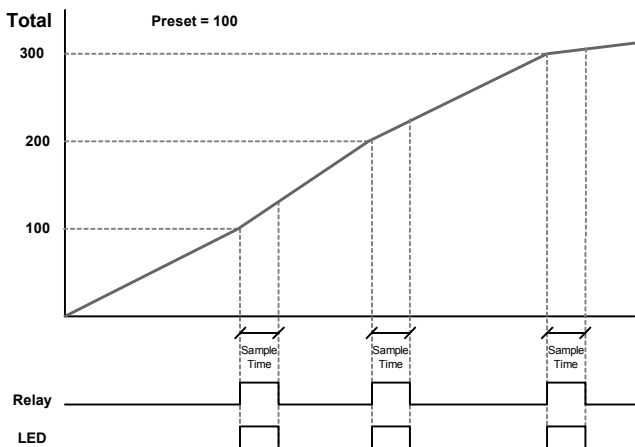

When the total reaches the preset, the relay trips and the sample time starts. After the sample time has elapsed, the relay resets. The cycle repeats every time the preset value is added to the total.



## Signal Loss or Loop Break Relay Operation

The following graph shows the loop break operation for a high alarm relay.

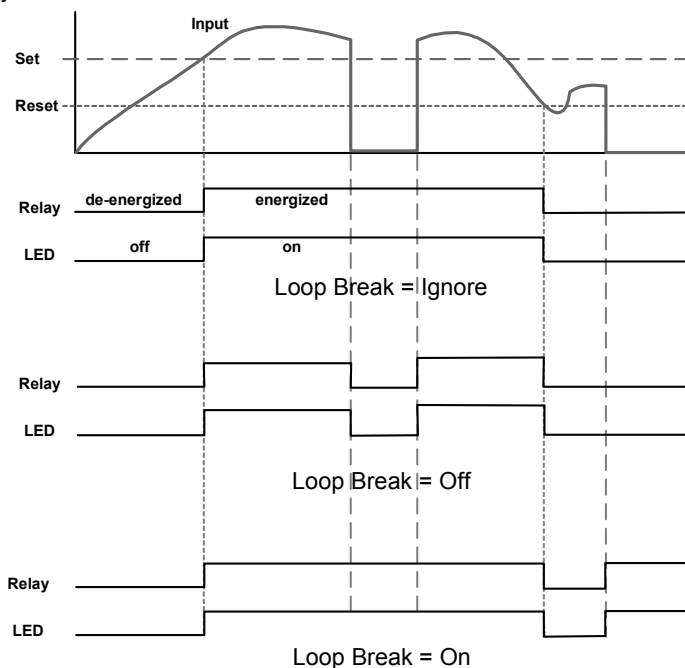

When the meter detects a break in the 4-20 mA loop, the relay will go to one of the following selected actions:

1. Turn on (Go to alarm condition)
2. Turn off (Go to non-alarm condition)
3. Ignore (Process as a low signal condition)

## Time Delay Operation

The following graphs show the operation of the time delay function.

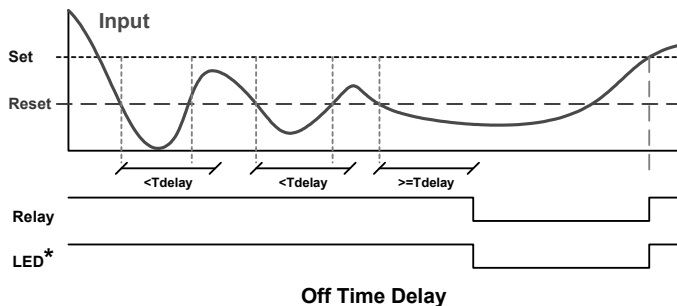
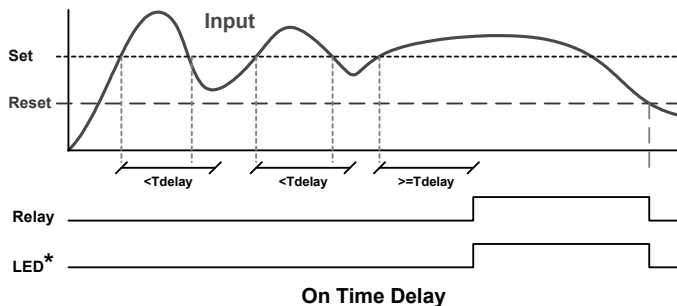

When the signal crosses the set point, the *On* time delay timer starts and the relay trips when the time delay has elapsed. If the signal drops below the set point (high alarm) before the time delay has elapsed, the *On* time delay timer resets and the relay does not change state. The same principle applies to the *Off* time delay.

\* Note: If “*Automatic or Manual (R-r-Rn)*” reset mode is selected, the LED follows the reset point and not the relay state when the relay is acknowledged.

## Relay Operation Details

### Overview

The relay capabilities of the meter expand its usefulness beyond simple indication to provide users with alarm and control functions. These capabilities include front panel alarm status LEDs as well as either 2 or 4 optional internal relays and/or 4 external relays expansion module. Typical applications include high or low temperature, level, pressure or flow alarms, control applications such as simple on/off pump control, pump alternation control for up to 8 pumps, and basic batch control. There are four basic ways the relays can be used:

1. High or Low Alarms with Latching or Non-Latching Relays
2. Simple On/Off Control with 100% Adjustable Deadband
3. Sampling (Based on Time)
4. Pump Alternation Control for up to 8 Pumps

### Relays Auto Initialization

When power is applied to the meter, the front panel LEDs and alarm relays will reflect the state of the input to the meter. The following table indicates how the alarm LEDs and relays will react on power-up based on the set and reset points:

Alarm #	HI or LO Alarm	Set Point	Reset Point	Power-Up Reading	Relay & LED
1	HI	1000	500	499	Off
2	LO	700	900	499	On
3	LO	250	400	499	Off
4	HI	450	200	499	On

### Fail-Safe Operation

The following table indicates how the relays behave based on the fail-safe selection for each relay:

Fail-Safe Selection	Non-Alarm State		Alarm State		Power Failure
	NO	NC	NO	NC	
Off	Open	Closed	Closed	Open	Relays go to non-alarm state
On	Closed	Open	Open	Closed	Relays go to alarm state

*Note: NO = Normally Open, NC = Normally Closed. This refers to the condition of the relay contacts when the power to the meter is off.*

### Front Panel LEDs

The LEDs on the front panel provide status indication for the following:

LED	Status
1	Alarm 1
2	Alarm 2
3	Alarm 3
4	Alarm 4

LED	Status
5	Alarm 5
6	Alarm 6
7	Alarm 7
8	Alarm 8

The meter is supplied with four alarm points that include front panel LEDs to indicate alarm conditions. This standard feature is particularly useful for alarm applications that require visual-only indication. The LEDs are controlled by the set and reset points programmed by the user. When the display reaches a set point for a high or low alarm, the corresponding alarm LED will turn on. When the display returns to the reset point the LED will go off. The front panel LEDs respond differently for latching and non-latching relays.

For non-latching relays, the LED is always off during normal condition and always on during alarm condition, regardless of the state of the relay (e.g. Relay acknowledged after alarm condition).

For latching relays, the alarm LEDs reflect the status of the relays, regardless of the alarm condition. The following tables illustrate how the alarm LEDs function in relation to the relays and the acknowledge button (Default: F3 key assigned to ACK):

### Latching and Non-Latching Relay Operation

The relays can be set up for latching (manual reset) or non-latching (automatic reset) operation.

#### Relay terminology for following tables

Terminology	Relay Condition
On	Alarm (Tripped)
Off	Normal (Reset)
Ack	Acknowledged

The On and Off terminology does not refer to the status of the relay's coil, which depends on the fail-safe mode selected.



**Warning!**

*In latching relay mode, latched relays will reset (un-latch) when power is cycled.*

**Non-Latching Relay (R<sub>1</sub>L<sub>1</sub>O)****Automatic reset only**

Condition	LED	Relay
Normal	Off	Off
Alarm	On	On
Ack (No effect)	On	On
Normal	Off	Off

In this application, the meter is set up for automatic reset (non-latching relay). Acknowledging the alarm while it is still present has no effect on either the LED or the relay. When the alarm finally goes away, the relay automatically resets and the LED also goes off.

**Non-Latching Relay (R<sub>1</sub>-M<sub>1</sub>R<sub>1</sub>)****Automatic + manual reset at any time**

Condition	LED	Relay
Normal	Off	Off
Alarm	On	On
Normal	Off	Off
Next Alarm	On	On
Ack	On	Off
Normal	Off	Off

In this application, the meter is set up for automatic and manual reset at any time (non-latching relay). The LED and the relay automatically reset when the meter returns to the normal condition.

The next time an alarm occurs, the operator acknowledges the alarm manually while the alarm condition still exists. This causes the relay to reset, but the LED stays on until the meter returns to the normal condition.

**Latching Relay (L<sub>1</sub>R<sub>1</sub>L<sub>1</sub>H)****Manual reset any time**

Condition	LED	Relay
Normal	Off	Off
Alarm	On	On
Ack	Off	Off

In this application, the meter is set up for manual reset at any time. Acknowledging the alarm even if the alarm condition is still present resets the relay and turns off the LED.

## Latching Relay (L<sub>t</sub>-L<sub>r</sub>)

Manual reset only after alarm condition has cleared

Condition	LED	Relay
Normal	Off	Off
Alarm	On	On
Ack (No effect)	On	On
Normal	On	On
Ack	Off	Off

In this application, the meter is set up for manual reset only after the signal passes the reset point (alarm condition has cleared). Acknowledging the alarm while it is still present has no effect on either the LED or the relay. When the alarm is acknowledged after it returns to the normal state, the LED and the relay go off. Notice that the LED remains on, even after the meter returns to the normal condition. This is because, for latching relays, the alarm LED reflects the status of the relay, regardless of the alarm condition.

### Acknowledging Relays

There are two ways to acknowledge relays programmed for manual reset:

1. Via the programmable front panel function keys F1-F3 (Default: F3 assigned to ACK)
2. Remotely via a normally open pushbutton wired across one of the digital inputs and the +5 V terminals on the digital I/O modules.

When the ACK button or the assigned digital input is closed, all relays programmed for manual reset are acknowledged.

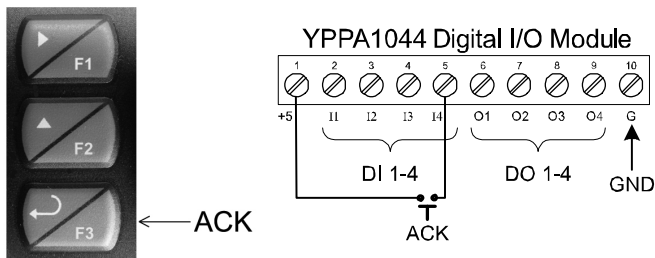

Figure 19: Acknowledge Relays w/Function Key or Digital Input

### Pump Alternation Control Applications (ALtErn)

For pump control applications where two or more similar pumps are used to control the level of a tank or a well, it is desirable to have all the pumps operate alternately. This prevents excessive wear and overheating of one pump over the lack of use of the other pumps.

Up to 8 relays can be set up to alternate every time an on/off pump cycle is completed. The set points and reset points can be programmed, so that the first pump on is the first pump off.

#### Application #1: Pump Alternation Using Relays 1 & 2

1. Relays 1 and 2 are set up for pump alternation.
2. Relays 3 and 4 are set up for low and high alarm indication.

#### Set and Reset Point Programming

Relay	Set Point	Reset Point	Function
1	30.000	10.000	Controls pump #1
2	35.000	5.000	Controls pump #2
3	4.000	9.000	Controls low alarm
4	40.000	29.000	Controls high alarm

#### Pump Alternation Operation

1. Pump #1 turns on when level reaches 30.000, when level drops below 10.000 pump #1 turns off.
2. The next time level reaches 30.000, pump #2 turns on, when level drops below 10.000 pump #2 turns off.
3. If the level doesn't reach 35.000 pump #1 and pump #2 will be operating alternately.
4. If pump #1 cannot keep the level below 35.000 pump #2 will turn on at 35.000, then as the level drops to 10.000 pump #1 turns off, pump #2 is still running and shuts off below 5.000.
5. Notice that with the set and reset points of pump #2 outside the range of pump #1, the first pump on is the first pump to go off. This is true for up to 8 alternating pumps, if setup accordingly.
6. Relay #3 will go into alarm if the level drops below 4.000 and relay #4 will go into alarm if the level exceeds 40.000.
7. Adding the 4 external relays expansion module allows using the 4 SPDT internal relays for pump alternation and the 4 SPST external relays for high, high-high, low, and low-low alarm indication.

**Application #2: Pump Alternation Using Relays 3 & 4**

1. Relays 1 and 2 are set up for low and high alarm indication.
2. Relays 3 and 4 are set up for pump alternation.

**Set and Reset Point Programming**

Relay	Set Point	Reset Point	Function
1	495	750	Controls low alarm
2	7500	6900	Controls high alarm
3	7000	900	Controls backup pump
4	6000	1000	Controls main pump

The following graphics provide a visual representation of a typical pump alternation application with high and low alarm monitoring:

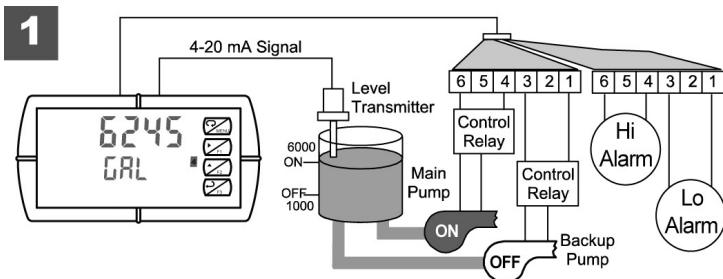

- Relay #4 turns the main pump on at 6000 gallons and turns it off at 1000 gallons.

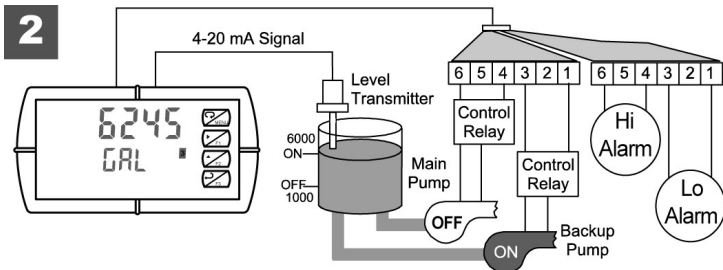

- With the Pump Alternation feature activated, the next time the level reaches 6000 gallons, relay #3 transfers and starts the backup pump.



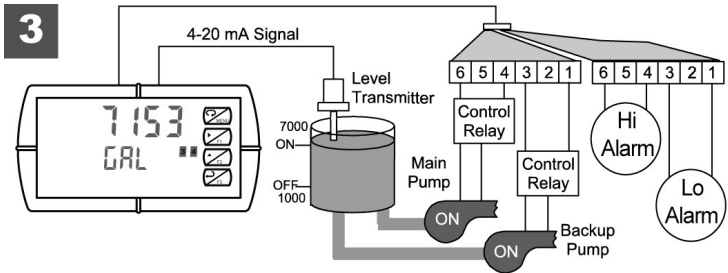

- If the backup pump is not able to keep up, and the level reaches 7000 gallons, relay #4 transfers and starts the main pump as well.

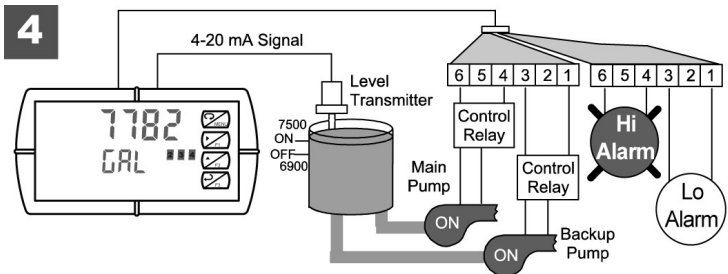

- Relay #2 trips the High Level Alarm at 7500 gallons and resets at 6900 gallons.

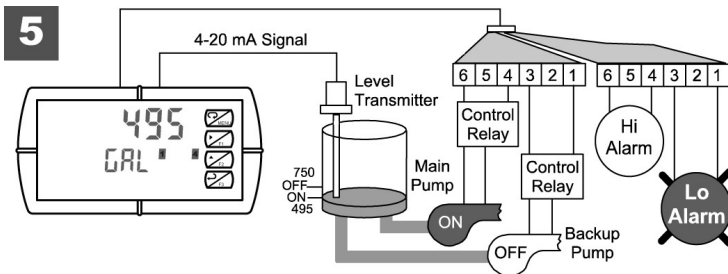

- Relay #1 trips the Low Level Alarm at 495 gallons and resets at 750 gallons.

## Setting Up the Interlock Relay (Force On) Feature

Relays 1-4 can be set up as interlock relays. To set up the relays for the interlock feature:

1. Access the *Setup – Relay – Action* menu and set the action to off.

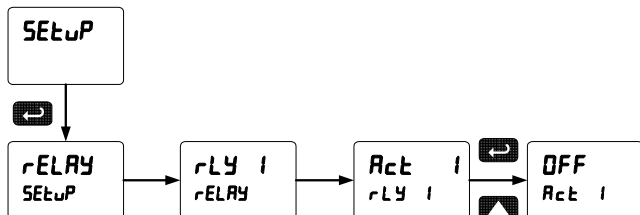

2. In the Advanced features – *User* menu program any of the digital inputs to *Force On* any of the internal relays (1-4).

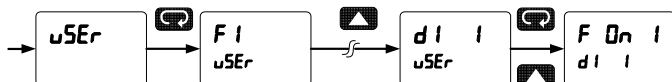

3. Connect a switch or dry contact between the +5V terminal and the corresponding digital input (dl-1 to dl-4) terminal.

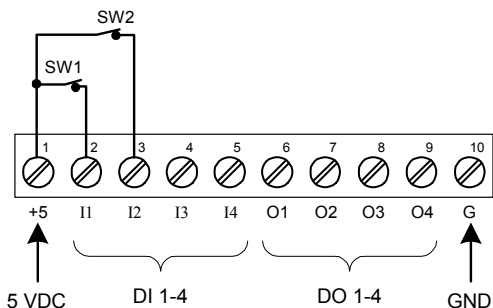

### Interlock Relay Operation Example

Relays 1 & 2 are configured to energize (their front panel LEDs are off) when SW1 & SW2 switches (above) are closed. If the contacts to these digital inputs are opened, the corresponding front panel LEDs flash indicating this condition. The processes being controlled by the interlock relay will stop, and will re-start only after the interlock relay is re-activated by the digital inputs (switches).

## Scaling the 4-20 mA Analog Output ( $R_{out}$ )

The 4-20 mA analog output can be scaled to provide a 4-20 mA signal for any display range selected.

No equipment is needed to scale the analog output; simply program the display values to the corresponding mA output signal.

The *Analog Output* menu is used to program the 4-20 mA output based on display values.

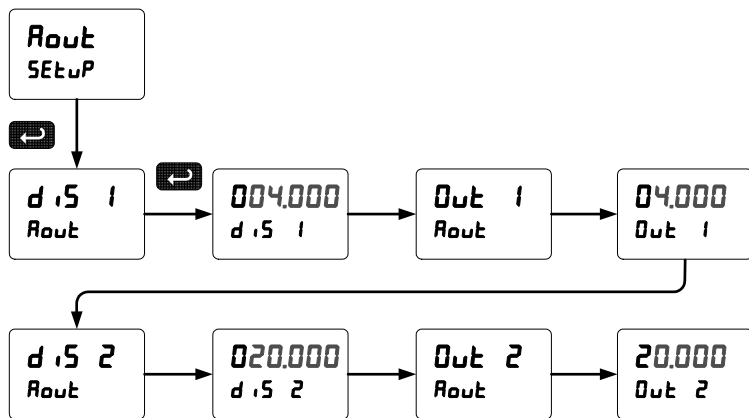

For instructions on how to program numeric values see *Setting Numeric Values*, page 34.

## Setting Up the Password (PASS)

The *Password* menu is used for programming three levels of security to prevent unauthorized changes to the programmed parameter settings and to program the non-resettable totalizer.

Pass 1: Allows use of function keys and digital inputs

Pass 2: Allows use of function keys, digital inputs and editing set/reset points

Pass 3: Restricts all programming, function keys, and digital inputs.

Total: Prevents resetting the total manually

Gtotal: Prevents resetting the grand total manually

### Protecting or Locking the Meter

Enter the *Password* menu and program a six-digit password.

For instructions on how to program numeric values see *Setting Numeric Values*, page 34.

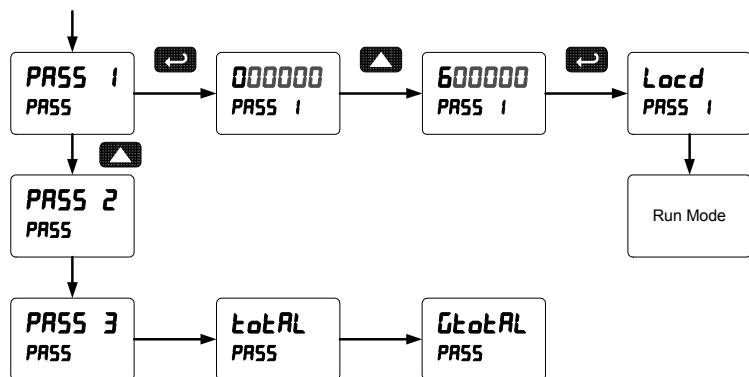

Record the password for future reference. If appropriate, it may be recorded in the space provided.

Model:	
Serial Number:	
Password 1:	_____
Password 2:	_____
Password 3:	_____
Total	_____
GTotal	_____

### Total Reset Password & Non-Resettable Total

The total and the grand total can be password-protected to prevent unauthorized total resets.

The grand total can be programmed as a non-resettable total by entering the password "050873".



#### Caution!

Once the Grand Total has been programmed as "non-resettable" the feature **cannot** be disabled.

## Making Changes to a Password Protected Meter

If the meter is password protected, the meter will display the message *Locd* (*Locked*) when the Menu button is pressed. Press the Enter button while the message is being displayed and enter the correct password to gain access the menu. After exiting the programming mode, the meter returns to its password protected condition.

### Disabling Password Protection

To disable the password protection, access the *Password* menu and enter the correct password twice, as shown below. The meter is now unprotected until a new password is entered.

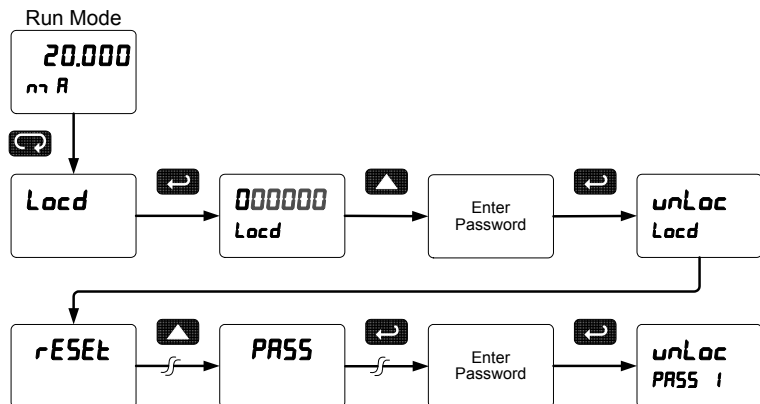

If the correct six-digit password is entered, the meter displays the message *unLoc* (*unlocked*) and the protection is disabled until a new password is programmed.

If the password entered is incorrect, the meter displays the message *Locd* (*Locked*) for about two seconds, and then it returns to Run Mode. To try again, press Enter while the *Locked* message is displayed.

#### Did you forget the password?

The password may be disabled by entering a master password once. If you are authorized to make changes, enter the master password 508655 to unlock the meter.

## Advanced Features Menu

To simplify the setup process, functions not needed for most applications are located in the *Advanced Features* menu.

Press and hold the Menu button for three seconds to access the advanced features of the meter.

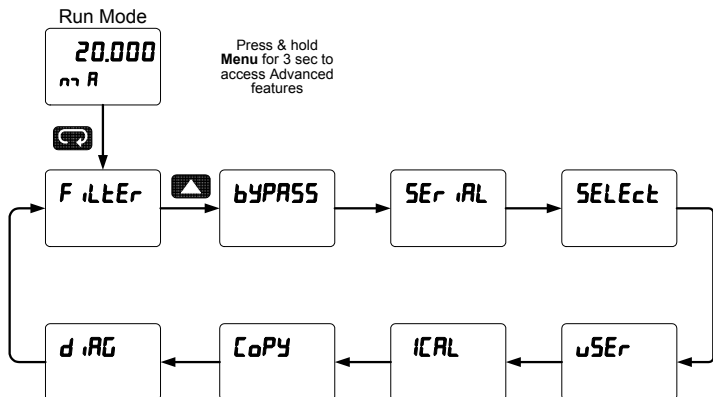

### Advanced Features Menu & Display Messages

The following table shows the functions and messages of the *Advanced Features* menu in the order they appear in the menu.

Display	Parameter	Action/Setting
F ILT	Filter	Set noise filter value
bYPASS	Bypass	Set filter bypass value
SERIAL	Serial	Set serial communication parameters
SLAVE ID	Slave ID	Set slave ID or meter address
baud	Baud rate	Select baud rate
tr dLY	Transmit delay	Set transmit delay for serial communication
PARITY	Parity	Select parity Even, Odd, or None with 1 or 2 stop bits
t-byt	Time byte	Set byte-to-byte timeout
SELECT	Select	Enter the Select menu (function, cutoff, out)
FUNCTION	Signal input conditioning	Select linear, square root, programmable exponent, or round horizontal tank function
LINEAR	Linear	Set meter for linear function and select number of linearization points
no Pts	Number of points	Set meter for 2 to 32-point linearization
CUTOFF	Cutoff	Set low-flow cutoff
SQRTE	Square root	Set meter for square root extraction
PROG E	Programmable exponent	Set meter for programmable exponent and enter exponent value
rh	Round horizontal tank	Set meter for round horizontal tank volume calculation
inch	Dimension(cm)	Calculate volume in gallons or meters
dIAm	Diameter	Enter the tank's diameter in inches
LEnGth	Length	Enter the tank's length in inches
CUTOFF	Cutoff	Set low-flow cutoff
ROUTPr	Analog output programming	Program analog output parameters
SOURCE	Source	Select source for the 4-20 mA output



Display	Parameter	Action/Setting
0-rRnG	<i>Overrange</i>	Program mA output for display overrange
u-rRnG	<i>Underrange</i>	Program mA output for display underrange
brERH	<i>Loop Break</i>	Set relay condition if loop break detected
ForcE	<i>Force</i>	Force analog output value for loop break
iGnorE	<i>Ignore</i>	Ignore loop break condition
rR RH	<i>Maximum</i>	Program maximum mA output allowed
rR rH	<i>Minimum</i>	Program minimum mA output allowed
CRL u	<i>Calibrate</i>	Calibrate 4-20 mA output (internal reference source used for scaling the output)
4 rR R	<i>4 mA output</i>	Enter mA output value read by milliamp meter with at least 0.001 mA resolution
20 rR R	<i>20 mA output</i>	Enter mA output value read by milliamp meter with at least 0.001 mA resolution
uSEr	<i>User I/O</i>	Assign function keys and digital I/O
F 1	<i>F1 function key</i>	Assign F1 function key
F 2	<i>F2 function key</i>	Assign F2 function key
F 3	<i>F3 function key</i>	Assign F3 function key
d 1 1	<i>Digital input 1</i>	Assign digital input 1 – 8, if expansion modules are connected
d 0 1	<i>Digital output 1</i>	Assign digital output 1 – 8, if expansion modules are connected
iCRL	<i>Internal source calibration</i>	Enter internal source calibration (used for scaling the meter without a signal source)
C CRL	<i>Current calibration</i>	Calibrating 4-20 mA current input (internal reference source used for scaling the input)
C L o	<i>Current low</i>	Calibrate low current input (e.g. 4 mA)
C H i	<i>Current high</i>	Calibrate high current input (e.g. 20 mA)
u CRL	<i>Voltage calibration</i>	Calibrating voltage input
u L o	<i>Voltage low</i>	Calibrate low voltage input (e.g. 0 V)
u H i	<i>Voltage high</i>	Calibrate high voltage input (e.g. 10 V)
CRPY	<i>Copy</i>	Enter copy function
SEnd	<i>Send</i>	Send meter settings to another meter

Display	Parameter	Action/Setting
<i>donE</i>	<i>Done</i>	Copy function completed
<i>d iAG</i>	<i>Diagnostics</i>	Display parameter settings
<i>F iLEr</i>	<i>Filter</i>	Display filter selection
<i>inPut</i>	<i>Input</i>	Input selection
<i>F iLEr</i>	<i>Filter</i>	Set noise filter level
<i>bYPASS</i>	<i>Bypass</i>	Set filter bypass level
<i>Function</i>	<i>Function</i>	Function selected
<i>SCALE</i>	<i>Scale</i>	Scaling parameter
<i>FRActor</i>	<i>K-factor</i>	K-factor value
<i>GALE</i>	<i>Gate</i>	Gate settings
<i>CutoFF</i>	<i>Cutoff</i>	Cutoff value
<i>t t b</i>	<i>Total time base</i>	Set time period
<i>t CF</i>	<i>Total correction factor</i>	Set correction factor
<i>t rSt</i>	<i>Total reset</i>	Set reset method
<i>Gr t b</i>	<i>Grand total time base</i>	Set grand total time period
<i>Gr CF</i>	<i>GT correction factor</i>	Set grand total correction factor
<i>Gr rSt</i>	<i>Grand total</i>	Set grand total reset method
<i>dSPLY</i>	<i>Display</i>	Display assignments
<i>rELAY</i>	<i>Relays</i>	Relay settings
<i>RoUt</i>	<i>Analog output</i>	Analog output scaling
<i>RoUtPr</i>	<i>Analog output programming</i>	Analog output programming
<i>SEr iAL</i>	<i>Serial</i>	Serial communication settings
<i>LEd t</i>	<i>LED test</i>	Test all LEDs
<i>inFo</i>	<i>Information</i>	Display software and S/N information

### **Noise Filter (F<sub>LEEr</sub>)**

The noise filter is available for unusually noisy signals that cause an unstable process variable display. The noise filter averages the input signal over a certain period. The filter level determines the length of time over which the signal is averaged. The filter level can be set between 2 and 199. The higher the filter level, the longer the averaging time and so the longer it takes the display to settle to its final value. Setting the filter level to zero disables the filter function.

### **Noise Filter Bypass (bYPASS)**

The noise filter bypass changes the behavior of the meter so that small variations in the signal are filtered out but large abrupt changes in the input signal are displayed immediately. The bypass value determines the minimum amount of signal change to be displayed immediately. All signal changes smaller than the bypass value are filtered or averaged by the meter. The noise filter bypass may be set between 0.1 and 99.9% of full scale.

## Modbus RTU Serial Communications (SEr iAL)

The meter is equipped with serial communications capability as a standard feature using Modbus RTU Serial Communication Protocol.

To communicate with a computer or other data terminal equipment, an RS-232 or RS-485 adapter option is required; see *Ordering Information* on page 7 for details.



**Warning!**

**Do not connect any equipment other than Yokogawa's expansion modules, cables, or meters to the RJ45 M-LINK connector. Otherwise damage will occur to the equipment and the meter.**

*Note: More detailed instructions are provided with each optional serial communications adapter.*

*Note: Refer to the **PROPLUS** Modbus Register Tables located at [www.yokogawa-usa.com](http://www.yokogawa-usa.com) for details.*

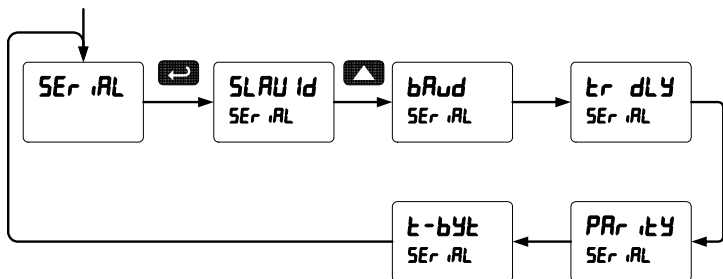

When using more than one meter in a multi-drop mode, each meter must be provided with its own unique address. The meter address (Slave ID) may be programmed between 1 and 247. The transmit delay may be set between 0 and 199 ms. The parity can be set to even, odd, or none with 1 or 2 stop bits.

The YPP6200 can also be connected to another YPP6200 with a special YPPA1200 cable, allowing the user to copy all the settings from one meter to another, using the *Copy* function.

## Select Menu (SELEct)

The *Select* menu is used to select the signal input conditioner applied to the input (linear, square root, programmable exponent, or round horizontal tank), low-flow cutoff, and analog output programming. The multi-point linearization is part of the linear function selection.

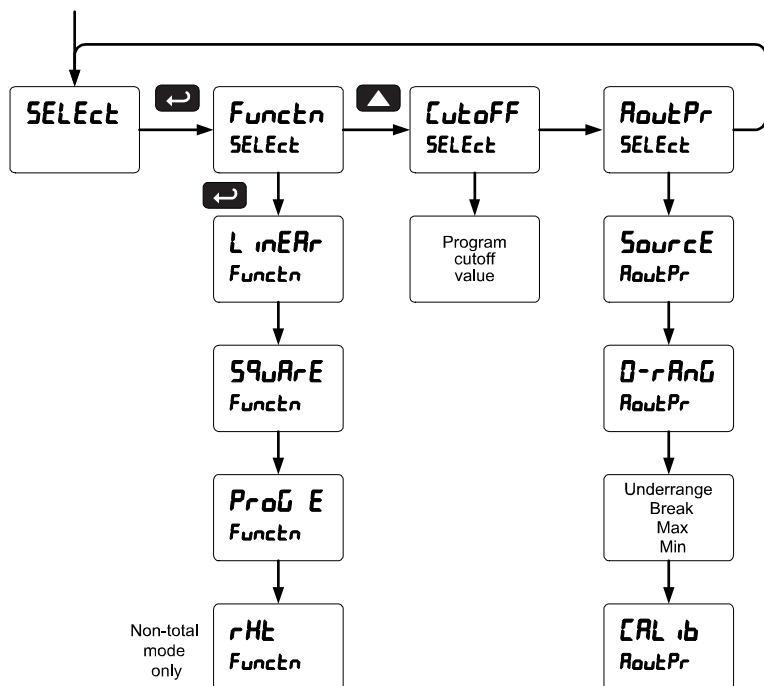

## Signal Input Conditioning (Functn)

The *Function* menu is used to select the signal input conditioner applied to the input: linear, square root, programmable exponent, or round horizontal tank volume calculation. The multi-point linearization is part of the linear function selection.

Meters are set up at the factory for linear function with 2-point linearization. The linear function provides a display that is linear with respect to the input signal.

**Square Root Linearization (SQUR E)**

The square root function can be used to linearize the signal from a differential pressure transmitter and display flow rate in engineering units.

**Programmable Exponent Linearization (PROG E)**

The programmable exponent can be used to linearize the signal from level transmitters in open-channel flow applications using weirs and flumes.

**Multi-Point Linearization (L inER)**

Meters are set up at the factory for linear function with 2-point linearization. Up to 32 linearization points can be selected under the linear function. The multi-point linearization can be used to linearize the display for non-linear signals such as those from level transmitters used to measure volume in odd-shaped tanks or to convert level to flow using weirs and flumes with complex exponent.

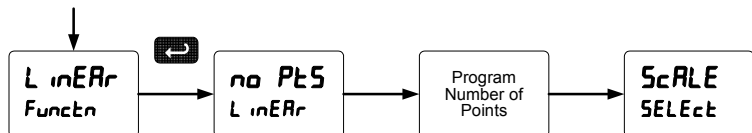

### Round Horizontal Tank Linearization (rHt)

This function automatically calculates the volume in a round horizontal tank with flat ends.

Set the display for the desired decimal point and engineering units before entering the round horizontal tank function. Select units, inches or cm for the tank dimension. Enter the diameter and the length in inches and the results are given in US gallons.

The meter can be scaled to display the volume in any engineering unit.

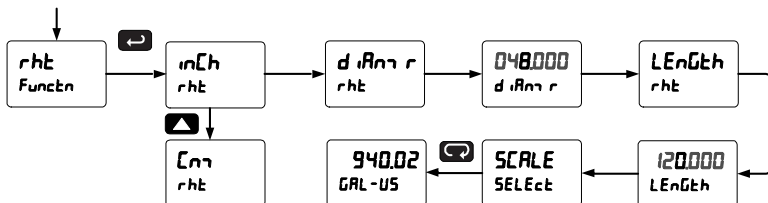

*Note: After Scale is displayed continue pressing the Enter button until the meter completes the scaling of the input and display values.*

### Changing the Volume from Gallons to Liters

In the above graphic, entering the 48" for the diameter and 120" for the length of the round horizontal tank, the meter automatically calculates that the volume of the tank is 940.02 gallons.

- Convert gallons to liters  
 1 US gallon = 3.7854 L  
 940.02 gal = 3558.4 L
- Go to the *Setup* menu and change the decimal point to 1 decimal.
- Go to the *Program – Scale* menu and press Enter until *d 5 2* is shown on the main display.
- Press Enter and change the display 2 value to 3558.4.
- The meter is now displaying the volume in liters.

*Note: The display can be scaled to display the volume in any engineering units.*

## Low-Flow Cutoff (Cutoff)

The low-flow cutoff feature allows the meter to be programmed so that the often-unsteady output from a differential pressure transmitter, at low flow rates, always displays zero on the meter.

The cutoff value may be programmed from 0 to 999999. The meter will display zero below the cutoff value. Programming the cutoff value to zero disables the cutoff feature.

## Analog Output Programming (Analog Pr)

The *Analog Output Programming* menu is used to program the behavior of the 4-20 mA output. The following parameters and functions are programmed in this menu:

1. Source: Source for generating the 4-20 mA output (e.g. PV)
2. Overrange: Analog output value with display in overrange condition
3. Underrange: Analog output value with display in underrange condition
4. Break: Analog output value when loop break is detected
5. Max: Maximum analog output value allowed regardless of input
6. Min: Minimum analog output value allowed regardless of input
7. Calibrate: Calibrate the internal 4-20 mA source reference used to scale the 4-20 mA output

### Analog Output Source

The source for generating the 4-20 mA output may be assigned to the rate/process variable, total, grand total, maximum or minimum value reached by the rate/process, or one of the set points, or the Modbus PV input.

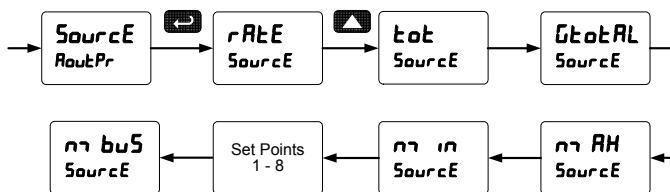

### Analog Output Calibration

To perform the analog output calibration it's recommended to use a milliamp meter with a resolution of at least 0.1  $\mu\text{A}$  to measure the output current. The values saved internally during this procedure are used for scaling the 4-20 mA output in the *Setup* menu.



## Programmable Function Keys User Menu (uSEr)

The *User* menu allows the user to assign the front panel function keys F1, F2, F3 and up to eight digital inputs to access most of the menus or to activate functions immediately (e.g. Reset max & min). Up to eight digital outputs can be assigned to a number of actions and functions executed by the meter (e.g. Alarms, relay acknowledgement, etc.).

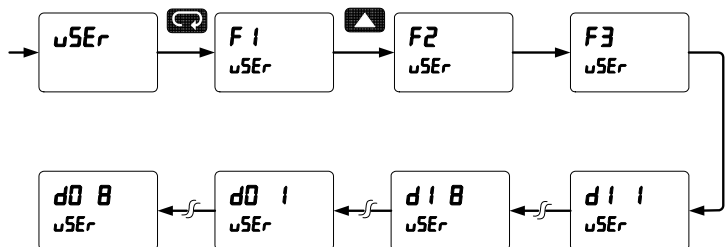

### Function Keys & Digital I/O Available Settings

Display	Description	Display	Description
RcH	Acknowledge relays	b u Lo	Min on big display
rESEt	Reset menu	b u HL	Max/min big display
rSt t	Reset total	L t Gt	Little grand total
rSt Gt	Reset grand total	L t H t	Max on little display
rSt H t	Reset max	L t Lo	Min on little display
rSt Lo	Reset min	L t HL	Max/min little display
rSt HL	Reset max & min	d ,SRbL	Disable function key
tArE	Capture tare	rr Enu	Menu button
rSt tr	Reset tare	r uht	Right arrow button/F1
rELAY	Relay menu	uP	Up arrow button/F2
SEt 1	Set point 1 - 8	EntEr	Enter button/F3
rLY d	Disable all relays	RLn r i	Alarm 1 - 8
rLY E	Enable all relays	F On 1	Force relay 1 on
u HoLd	Relays & output hold	F On 2	Force relay 2 on
d HoLd	Display hold	F On 3	Force relay 3 on
b u H t	Max on big display	F On 4	Force relay 4 on

### Tare (tArE)

The tare function zero's out the display. In the case of scale weight, tare is used to eliminate container weight and provide net weight readings. There are two tare functions; Capture Tare and Reset Tare.

This function may only be used when Total (tOLRL) is set to No (nO).



### Internal Source Calibration (ICRL)

The meter is factory calibrated prior to shipment to read in milliamps and volts depending on the input selection. The calibration equipment is certified to NIST standards.

The internal source allows the user to scale the meter without applying a signal.

The use of calibrated signal sources is necessary to perform the internal source calibration of the meter.

Check calibration of the meter at least every 12 months. Each input must be recalibrated separately.

#### Notes:

1. *If meter is in operation and it is intended to accept only one input type (e.g. 4-20 mA), recalibration of other input is not necessary.*
2. *Allow the meter to warm up for at least 15 minutes before performing the internal source calibration procedure.*

The *Internal calibration* menu is part of the *Advanced Features* menu.

1. Press and hold the Menu button for three seconds to access the advanced features of the meter.

2. Press the Up arrow button to scroll to the *Internal calibration* menu (  $\text{I CAL}$  ) and press Enter.
3. The meter displays either current calibration (  $\text{C CAL}$  ) or voltage calibration (  $\text{V CAL}$  ), according to the input setup. Press Enter to start the calibration process.

**Example of Internal Calibration for current input:**

4. The meter displays *low* input current message (  $\text{C Lo}$  ). Apply the low input signal and press Enter. The display flashes for a moment while the meter is accepting the low input signal.
5. After the display stops flashing, a number is displayed with the left-most digit brighter than the rest. The bright digit is the active digit that can be changed by pressing the Up arrow button. Press the Right arrow button to move to the next digit.
6. Set the display value to correspond to the input signal being calibrated, typically 4.000 mA.
7. The display moves to the *high* input calibration (  $\text{C Hi}$  ). Apply the high input signal and press Enter.
8. Set the display for the high input calibration, in the same way as it was set for the low input calibration, typically 20.000 mA.

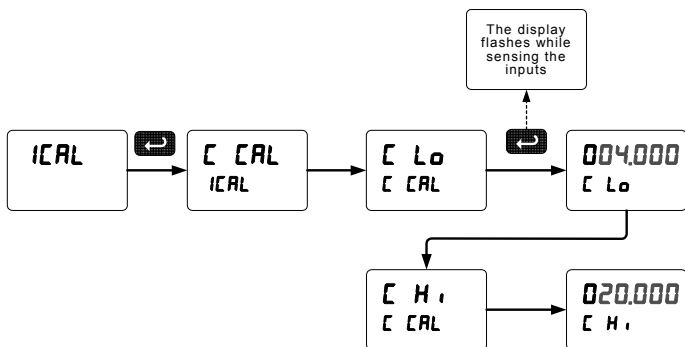

The graphic above shows the calibration of the current input. The voltage input is calibrated in a similar way.

**Tips:**

- Low and high input signals can be any valid values within the range of the meter.
- Observe minimum input span requirements between input 1 and input 2.
- Low input should be less than high input signal.

**Error Message (*Error*)**

An error message indicates that the calibration or scaling process was not successful.

After the error message is displayed, the meter reverts to input 2 during calibration or scaling and to input 1 during internal calibration, allowing the appropriate input signal to be applied or programmed.

The error message might be caused by any of the following conditions:

1. Input signal is not connected to the proper terminals, or it is connected backwards.
2. Wrong signal selection in *Setup* menu.
3. Minimum input span requirements not maintained.

**Minimum Input Span**

The minimum input span is the minimum difference between input 1 and input 2 signals required to complete the calibration or scaling of the meter.

Input range	Input 1 & input 2 span
4-20 mA	0.15 mA
±10 VDC	0.10 VDC

## Meter Copy Function (COPY)

The *Copy* function is used to copy (or clone) all the settings from one meter to other meters requiring exactly the same setup and programming (*i.e.* type of input, scaling, decimal point, filter, bypass, etc.).



**Warning!**

***Only the YPPA1200 meter copy cable must be used for meter-to-meter interfacing. The YPPA1200 is a special eight-conductor flat cable with two wires swapped.***

***Using standard CAT5 or other cable will cause damage to both meters.***

YPPA1200 Meter Copy Cable



**Figure 20: Meter Copy Connection**

### ***Copy Function Requirements***

*To successfully copy settings from one meter to another, both meters must have:*

- 1. Same software version*
- 2. Same baud rate setting*

*See Determining Software Version, page 89 for instructions.*

### Meter Copy or Cloning Instructions



**Caution!**

*Do not connect the two meters to the same signal source while cloning. Internal calibration may be affected.*

1. Connect two meters using a YPPA1200 meter copy cable.



**Warning!**

***Use YPPA1200 meter copy cable only!***

***Using standard CAT5 or other cable will cause damage to both meters.***

2. Do not connect the two meters to the same signal source.
3. Power up both meters. Leave Clone meter in Run Mode.
4. Enter the *Advanced Features* menu of the Master meter see *Advanced Features Menu* page 71.
5. Scroll to the *Copy* function using the Up arrow button then press Enter.
6. The meter displays the message *SEnd*. Press Enter, the display flashes while sending data. The message *donE* is displayed when copying is completed.

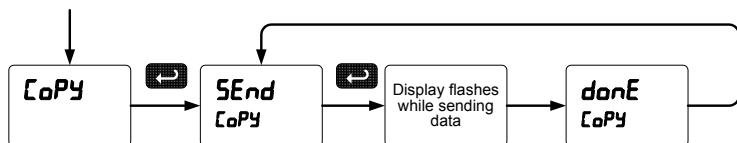

7. The Clone meter displays the message *CPY rE* while being programmed then the message *donE* when copying is completed. The meter initializes and returns to Run Mode using the same settings as the Master.
8. If meter to be cloned does not respond to the data being sent, refer to ***Copy Function Requirements*** above.





## METER OPERATION

The meter is capable of accepting current (0-20 mA, 4-20 mA) and voltage signals (0-5 V, 1-5 V, 0-10 V,  $\pm 10$  V) and displaying these signals in engineering units from -99999 to 999999 (e.g. a 4-20 mA signal could be displayed as -50.000 to 50.000).

The dual-line display can be customized by the user to operate in such a way as to satisfy a specific application. Typically the main display is used for the process variable; while the second display is used for engineering units, custom legend, total, grand total, or set point indication.

The meter can be set up to display the analog input on the main display and the Modbus input on the second display. The relays and analog output can be programmed to operate from the Modbus PV input.

## Front Panel Buttons Operation

Button Symbol	Description
	Press to enter or exit Programming Mode, view settings, or exit max/min readings
	Press to reset max/min readings or other parameter/function assigned through the <i>User</i> menu
	Press to display max/min readings or other parameter/function assigned through the <i>User</i> menu
	Press to acknowledge relays or other parameters/function assigned through the <i>User</i> menu

## Function Keys Operation

During operation, the programmable function keys operate according to the way they have been programmed in the *Advanced Features – User* menu.

The table above shows the factory default settings for F1, F2, and F3.

## Maximum/Minimum Readings

The max & min readings (peak & valley) reached by the process can be displayed either continuously or momentarily:

1. Display briefly by assigning to the F1-F3 function keys or to the digital inputs in the *User* menu.
2. Display continuously by assigning either display to max/min through the *Display* menu.

Any of the F1-F3 function keys (buttons) and the digital inputs can be programmed to reset the max & min readings. The meters are set at the factory to display the max reading by pressing the Up arrow/F2 button and to use the Right arrow/F1 button to access the *Reset* menu.

### To display max reading using function key with factory defaults:

1. Press Up arrow/F2 button to display maximum reading since the last reset/power-up.
2. To reset max/min press Right arrow/F1 button to access the Reset menu. The max & min displays are reset to actual values.
3. Press Menu to exit max/min display reading.

### To display max/min readings continuously:

Assign either display to Max (d H i), Min (d L o), or toggle between Max and Min (d HL) every 10 seconds.

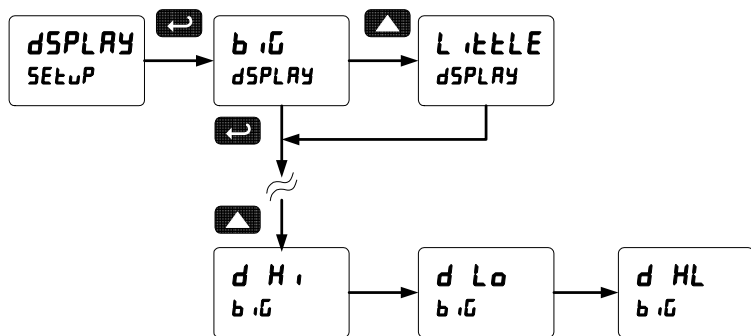



## TROUBLESHOOTING

The rugged design and the user-friendly interface of the meter should make it unusual for the installer or operator to refer to this section of the manual. However, due to the many features and functions of the meter, it's possible that the setup of the meter does not agree with what an operator expects to see.

If the meter is not working as expected, refer to the *Diagnostics* menu and recommendations below.

### ***Diagnostics* Menu (d iRG)**

The *Diagnostics* menu is located in the *Advanced Features* menu, to access *Diagnostics* menu see *Advanced Features Menu*, page 71.

It provides an easy way to view the programmed parameter settings for troubleshooting purposes. Press the Enter button to view the settings and the Menu button to exit at any time.

For a description of the diagnostic messages, see *Advanced Features Menu & Display Messages*, page 72.

### **Determining Software Version**

To determine the software version of a meter:

1. Go to the *Diagnostics* menu (d iRG) and press Enter button.
2. Press Up arrow button and scroll to Information menu ( iRFa).
3. Press Enter to access the software number (SFt) and version (iEr) information. Write down the information as it is displayed. Continue pressing Enter until all the information is displayed.
4. The meter returns to Run Mode after displaying all the settings.

## Reset Meter to Factory Defaults

When the parameters have been changed in a way that is difficult to determine what's happening, it might be better to start the setup process from the factory defaults.

### Instructions to load factory defaults:

1. Enter the *Advanced Features* menu. See *Advanced Features Menu*, page 71.
2. Press Up arrow to go to *Diagnostics* menu
3. Press and hold Right arrow for five seconds, press Enter when display flashes *rESEt*.  
Note: If Enter is not pressed within three seconds, the display returns to the *Diagnostics* menu.
4. The meter goes through an initialization sequence (similar as on power-up), and loads the factory default settings.

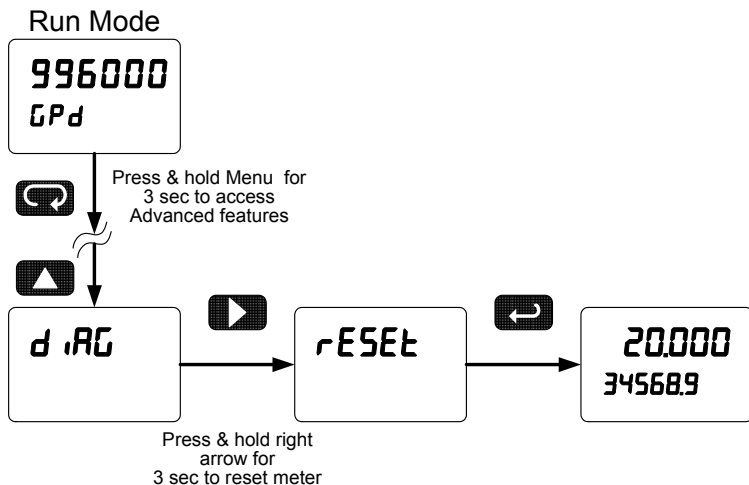

### Factory Defaults & User Settings

The following table shows the factory setting for most of the programmable parameters on the meter. Next to the factory setting, the user may record the new setting for the particular application.

Model: \_\_\_\_\_ S/N: \_\_\_\_\_ Date: \_\_\_\_\_

Parameter	Display	Default Setting	User Setting
Input type	<i>inPut</i>	4-20 mA	
Total	<i>YES</i>	Total enabled	
Filter	<i>F ILtEr</i>	70	
Bypass	<i>bYPASS</i>	0.2	
Function	<i>FunctiOn</i>	Linear	
Number of points	<i>no Pts</i>	2	
Programming	<i>Prog</i>	Scale	
Input 1	<i>inP 1</i>	4.000 mA	
Display 1	<i>d iS 1</i>	4.000	
Input 2	<i>inP 2</i>	20.000 mA	
Display 2	<i>d iS 2</i>	20.000	
Decimal point	<i>ddddddd</i>	3 places	
Cutoff value	<i>CuToFF</i>	0.000 (disabled)	
Display assignment	<i>dSPLY</i>		
Big display (Main)	<i>b iG</i>	Rate/Process	
Little display (Small)	<i>L iLtLE</i>	Total value	
Display intensity	<i>d- intY</i>	8	
Total time base	<i>t tB</i>	Second	
Total conversion factor	<i>t CF</i>	1.000	

Parameter	Display	Default Setting	User Setting
Total reset	$t r5t$	Manual	
Grand total time base	$Ut tb$	Second	
Grand total conversion factor	$t CF$	1.000	
Grand total reset	$t r5t$	Manual	
Relay 1 assignment	$RS Un1$	Total	
Relay 2 assignment	$RS Un2$	Total	
Relay 3 assignment	$RS Un3$	Rate	
Relay 4 assignment	$RS Un4$	Rate	
Relay 1 action	$Rct 1$	Automatic	
Relay 1 set point	$SEt 1$	1.000	
Relay 1 reset point	$r5t 1$	0.000	
Relay 2 action	$Rct 2$	Automatic	
Relay 2 set point	$SEt 2$	2.000	
Relay 2 reset point	$r5t 2$	0.000	
Relay 3 action	$Rct 3$	Automatic	
Relay 3 set point	$SEt 3$	3.000	
Relay 3 reset point	$r5t 3$	2.500	
Relay 4 action	$Rct 4$	Automatic	
Relay 4 set point	$SEt 4$	4.000	
Relay 4 reset point	$r5t 4$	3.500	
Fail-safe relay 1	$FLS 1$	Off	
Fail-safe relay 2	$FLS 2$	Off	
Fail-safe relay 3	$FLS 3$	Off	

Parameter	Display	Default Setting	User Setting
Fail-safe relay 4	<i>FLS 4</i>	Off	
On delay relay 1	<i>On 1</i>	0.0 sec	
Off delay relay 1	<i>OFF 1</i>	0.0 sec	
On delay relay 2	<i>On 2</i>	0.0 sec	
Off delay relay 2	<i>OFF 2</i>	0.0 sec	
On delay relay 3	<i>On 3</i>	0.0 sec	
Off delay relay 3	<i>OFF 3</i>	0.0 sec	
On delay relay 4	<i>On 4</i>	0.0 sec	
Off delay relay 4	<i>OFF 4</i>	0.0 sec	
Loop break relay 1	<i>IGNOR E</i>	Ignore	
Loop break relay 2	<i>IGNOR E</i>	Ignore	
Loop break relay 3	<i>IGNOR E</i>	Ignore	
Loop break relay 4	<i>IGNOR E</i>	Ignore	
Display 1 analog out	<i>d IS 1</i>	4.000	
Output 1 value	<i>Out 1</i>	4.000 mA	
Display 2 analog out	<i>d IS 2</i>	20.000	
Output 2 value	<i>Out 2</i>	20.000 mA	
Source analog output	<i>SourcE</i>	Rate/process	
Overrange output	<i>O-rANd</i>	21.000 mA	
Underrange output	<i>u-rANd</i>	3.000 mA	
Loop break output	<i>brERH</i>	1.000 mA	
Maximum output	<i>rr RH</i>	23.000 mA	
Minimum output	<i>rr rn</i>	0.000 mA	

Parameter	Display	Default Setting	User Setting
Slave ID (Address)	<i>SLAVE id</i>	247	
Baud rate	<i>bRud</i>	9600	
Transmit delay	<i>tR dLY</i>	10 ms	
Parity	<i>PRr iLY</i>	Even	
Byte-to-byte timeout	<i>t-byt</i>	010 (0.1 sec)	
F1 function key	<i>F 1</i>	Reset max & min	
F2 function key	<i>F 2</i>	Big display: Max (Hi)	
F3 function key	<i>F 3</i>	Acknowledge relays	
Digital input 1	<i>d i 1</i>	Menu	
Digital input 2	<i>d i 2</i>	Right arrow	
Digital input 3	<i>d i 3</i>	Up arrow	
Digital input 4	<i>d i 4</i>	Enter	
Digital output 1	<i>dO 1</i>	Alarm 1	
Digital output 2	<i>dO 2</i>	Alarm 2	
Digital output 3	<i>dO 3</i>	Alarm 3	
Digital output 4	<i>dO 4</i>	Alarm 4	
Password 1	<i>PRSS 1</i>	000000 (unlocked)	
Password 2	<i>PRSS 2</i>	000000 (unlocked)	
Password 3	<i>PRSS 3</i>	000000 (unlocked)	
Total password	<i>tOtAL</i>	000000 (unlocked)	
Grand total password	<i>GtOtAL</i>	000000 (unlocked)	

## Troubleshooting Tips

Symptom	Check/Action
No display at all	Check power at power connector
Not able to change setup or programming, <i>Lcd</i> is displayed	Meter is password-protected, enter correct six-digit password to unlock
Meter displays error message during calibration ( <i>Error</i> )	Check: <ol style="list-style-type: none"> <li>Signal connections</li> <li>Input selected in <i>Setup</i> menu</li> <li>Minimum input span requirements</li> </ol>
Meter displays 999999 -999999	Check: <ol style="list-style-type: none"> <li>Input selected in <i>Setup</i> menu</li> <li>Corresponding signal at Signal connector</li> </ol>
Display is unstable	Check: <ol style="list-style-type: none"> <li>Input signal stability and value</li> <li>Display scaling vs. input signal</li> <li>Filter and bypass values (increase)</li> </ol>
Display response is too slow	Check filter and bypass values
Display reading is not accurate	Check: <ol style="list-style-type: none"> <li>Signal input conditioner selected: Linear, square root, etc.</li> <li>Scaling or calibration</li> </ol>
Display does not respond to input changes, reading a fixed number	Check: Display assignment, it might be displaying max, min, or set point.
Display alternates between <ol style="list-style-type: none"> <li><i>H i</i> and a number</li> <li><i>L o</i> and a number</li> </ol>	Press Menu to exit max/min display readings.
Relay operation is reversed	Check: <ol style="list-style-type: none"> <li>Fail-safe in <i>Setup</i> menu</li> <li>Wiring of relay contacts</li> </ol>
Relay and status LED do not respond to signal	Check: <ol style="list-style-type: none"> <li>Relay action in <i>Setup</i> menu</li> <li>Set and reset points</li> </ol>
Flashing relay status LEDs	Relays in manual control mode or relay interlock switches opened.
Meter not communicating with application programs	Check: <ol style="list-style-type: none"> <li>Serial adapter and cable</li> <li>Serial settings</li> <li>Meter address and baud rate</li> </ol>
If the display locks up or the meter does not respond at all	Cycle the power to reboot the microprocessor.
Other symptoms not described above	Call Technical Support for assistance.

## Alphabetical List of Display Functions & Messages

Display	Parameter	Action/Setting Description
20 mA R	20 mA output	Enter mA output value read by milliamp meter with at least 0.001 mA resolution
4 mA R	4 mA output	Enter mA output value read by milliamp meter with at least 0.001 mA resolution
999999 -999999	Flashing display	Overrange condition Underrange condition
RcH	Acknowledge	Acknowledge relays
Rc1 i	Action 1	Set relay 1 action
RLn R i	Alarm 1	Assign digital output to Alarm 1 – 8
RLtErn	Alternate	Set relay for pump alternation control (relays assigned to rate)
R-manRn	Auto-manual	Set relay for automatic & manual reset any time
Rout	Analog output	Analog output scaling
RoutPr	Analog output programming	Analog output programming
R5 n i	Assign 1	Relay 1 assignment
R55 n n	Assignment	Assign relays to rate, total, or grand total
Ruto	Automatic	Press Enter to set meter for automatic operation
Ruto	Automatic	For automatic reset
bRud	Baud rate	Select baud rate
b n	Big display	Press Enter to assign the Main display parameter (default: PV or rate)
b n H i	Max on big display	Assign digital input to display max on the main display
b n HL	Max/min big display	Assign digital input to toggle max/min on the main display
b n Lo	Min on big display	Assign the digital input to display min on the main display
brERH	Loop break	Set relay condition if loop break detected (For mA input only)



Display	Parameter	Action/Setting Description
bYPASS	<i>Bypass</i>	Set filter bypass value
[ CR ]	<i>Current calibration</i>	Calibrating 4-20 mA current input (internal reference source used for scaling the input)
[ Hi ]	<i>Current high</i>	Calibrate high current input (e.g. 20 mA)
[ Lo ]	<i>Current low</i>	Calibrate low current input (e.g. 4 mA)
[ TARE ]	<i>Capture tare</i>	Capture tare
[ CAL ]	<i>Calibrate</i>	Enter the <i>Calibrate</i> menu
[ CAL ]	<i>Calibrate</i>	Calibrate 4-20 mA output (internal reference source used for scaling the output)
[ CONTROL ]	<i>Control</i>	Enter <i>Control</i> menu
[ COPY ]	<i>Copy</i>	Enter copy function
[ CUTOFF ]	<i>Cutoff</i>	Cutoff value
d Hi	<i>Display high</i>	Select to display the max
d H&L	<i>Display H&amp;L</i>	Select to display the max & min toggling
d HOLD	<i>Display hold</i>	Display hold
d Lo	<i>Display low</i>	Select to display the min
d PCT	<i>Display PCT</i>	Select to display percent of PV1 (dual scale display)
d PV	<i>Display PV</i>	Select to display PV
d PV1	<i>Display PV1</i>	Select to display PV1 (dual scale display)
d PV2	<i>Display PV2</i>	Select to display PV2 (dual scale display)
d r-u	<i>Display r-u</i>	Select to display rate and units
d UNITS	<i>Display units</i>	Select to display engineering units or label
d DEC PT	<i>Decimal point</i>	Set decimal point for rate, total, grand total
d RELAY	<i>Delay</i>	Enter relay <i>Time Delay</i> menu
d I I	<i>Digital input 1</i>	Assign digital input 1-8, if expansion modules are connected
d RC	<i>Diagnostics</i>	Display parameter settings
d DIAMETER	<i>Diameter</i>	Enter the tank's diameter in inches

Display	Parameter	Action/Setting Description
d- IntY	Display intensity	Set display intensity level from 1 to 8
d 1	Display 1	Program display 1 value
d 2	Display 2	Program display 2 value
d .5RbL		Disable function key
dLY 1	Delay 1	Enter relay 1 time delay setup
dO 1	Digital output 1	Assign digital output 1 – 8, if expansion modules are connected
donE	Done	Copy function completed
dSEt 1	Display set 1	Select to display set point 1 (1-8)
dSPLRy	Display	Enter the Display menu
EnTEr	Enter	Assign digital input to Enter button/F3
Error	Error	Error, calibration not successful, check signal or programmed value
F On 1	Force On 1	Force relay 1 on using digital input (1-4)
F 1	F1 function key	Assign F1 function key
F 2	F2 function key	Assign F2 function key
F 3	F3 function key	Assign F3 function key
FR iLSF	Fail-safe	Enter Fail-safe menu
F iLEEr	Filter	Set noise filter value
FLS 1	Fail-safe 1	Set relay 1 fail-safe operation
ForcE	Force	Force analog output value for loop break
FunctiOn	Function	Select linear, square root, programmable exponent, or round horizontal tank function
G tOTAL	Grand total	Assign relay to grand total
Gt CF	Grand total conversion factor	Program grand total conversion factor
Gt rSt	Grand total reset	Program grand total rest mode: auto or manual

Display	Parameter	Action/Setting Description
GrT tB	<i>Grand total time base</i>	Program grand total time base
GrToERL	<i>Grand total password</i>	Set or enter password for manual reset
iCAL	<i>Internal source calibration</i>	Enter internal source calibration (used for scaling the meter without a signal source)
iGnorE	<i>Ignore</i>	Ignore loop break condition
Info	<i>Information</i>	Display software and S/N information
InP 1	<i>Input 1</i>	Calibrate input 1 signal or program input 1 value
InP 2	<i>Input 2</i>	Calibrate input 2 signal or program input 2 value (up to 32 points)
InPul	<i>Input</i>	Input selection
LRECH	<i>Latching</i>	Set relay for latching operation (relays assigned to rate)
LEd t	<i>LED test</i>	Test all LEDs
LEnGth	<i>Length</i>	Enter the tank's length in inches
LEUEL	<i>Level</i>	Enter <i>Level</i> menu and select <i>Yes</i> for dual-scale display or <i>No</i> for single scale display
L inERr	<i>Linear</i>	Set meter for linear function and select number of linearization points
L t GrT	<i>Grand total on little display</i>	Assign the digital input to display the grand total on the little display
L t H i	<i>Max on little display</i>	Assign digital input to display max on the small display
L t HL	<i>Max/min little display</i>	Assign the digital input to toggle max/min on the small display
L t Lo	<i>Min on little display</i>	Assign digital input to display min on the small display
L tLE	<i>Little display</i>	To assign the small display parameters
Locd	<i>Locked</i>	Enter password to unlock meter
Lt-CLr	<i>Latching-cleared</i>	Set relay for latching operation with manual reset only after alarm condition has cleared (relays assigned to rate)

Display	Parameter	Action/Setting Description
00 R	4-20 mA	Set meter for 4-20 mA input
00 Rn	Manual	To manually control
00 RH	Maximum	Program maximum mA output allowed
00 bUS	Modbus	Select to display Modbus input or to assign Modbus input as the analog output source
00 Ebu	Menu button	Assign digital input to Menu button
00 in	Minimum	Program minimum mA output allowed
00 PLS	Number of points	Set meter for 2 to 32-point linearization
00nr St	Non-resettable	Non-resettable grand total set after entering "050873" for Gtotal password
0 Hold	Relays output hold	Assign digital input to hold all relays state
0FF	Off	Disable relay and front panel status LED, turn relays off, program off time delay
0FF 1	Off	Set relay 1 Off time delay
0n	On	Enable fail-safe operation, turn relays on, program on time delay
0n 1	On	Set relay 1 On time delay
0-r RnG	Overrange	Program mA output for display overrange
0ut 1	Output 1	Program output 1 value (e.g. 4.000 mA)
0ut 2	Output 2	Program output 2 value (e.g. 20.000 mA)
PASS	Password	Enter the Password menu
PASS 1	Password 1	Set or enter Password 1
PASS 2	Password 2	Set or enter Password 2
PASS 3	Password 3	Set or enter Password 3
Prog	Program	Enter the Program menu
Prog E	Programmable exponent	Set meter for programmable exponent and enter exponent value
rRate	Rate	Assign relay to rate
rELAY	Relay	Enter the Relay menu

Display	Parameter	Action/Setting Description
rESEt	Reset	To access the <i>Reset</i> menu
rHt	Round horizontal tank	Set meter for round horizontal tank volume calculation
r →Ht	Right arrow	Assign digital input to Right arrow button/F1
rLY 1	Relay 1	Relay 1 setup
rLY 2	Relay 2	Relays 2-8 setup <i>Note: Relays 5-8 are shown, only if expansion relay module is installed.</i>
rLY d	Disable relay	Assign digital input to disable all relays
rLY E	Enable relay	Assign digital input to enable all relays
rSt 1	Reset 1	Program reset point 1
rSt Gt	Reset grand total	To reset grand total
rSt H i	Reset high	Press Enter to reset max display
rSt HL	Reset high & low	Press Enter to reset max & min displays
rSt Lo	Reset low	Press Enter to reset min display
rSt t	Reset Total	Reset total
SAMPL	Sampling	Set relay for sampling operation
SCALE	Scale	Enter the <i>Scale</i> menu
SELEct	Select	Enter the <i>Select</i> menu (function, cutoff, out)
SEnd	Send	Send meter settings to another meter
SEr iAL	Serial	Set serial communication parameters
SEt 1	Set 1	Program set point 1
SEtUP	Setup	Enter <i>Setup</i> menu
SLAVE ID	Slave ID	Set Slave ID or meter address
SourcE	Source	Select source for the 4-20 mA output
SqURrE	Square root	Set meter for square root extraction
tRrESEt	Reset tare	Reset tare

Display	Parameter	Action/Setting Description
ƒ CF	Total conversion factor	Program total conversion factor
ƒ dLY	Time delay	Program time delay for total auto reset
ƒ r5ƒ	Total reset	Program total rest mode: auto or manual
ƒ ƒb	Total time base	Program total time base
ƒ oƒRL	Total	Enable or disable totalizer features
ƒ r dLY	Transmit delay	Set transmit delay for serial communication
unL oC	Unlocked	Program password to lock meter
uP	Up arrow	Assign digital input to up arrow button/F2
u-r RnG	Underrange	Program mA output for display underrange
u5Er	User I/O	Assign function keys and digital I/O
U ƒRL	Voltage calibration	Calibrating voltage input
U H i	Voltage high	Calibrate high voltage input (e.g. 10 V)
U Lo	Voltage low	Calibrate low voltage input (e.g. 0 V)
UoLƒ	0-10 VDC	Set meter for ±10 VDC input

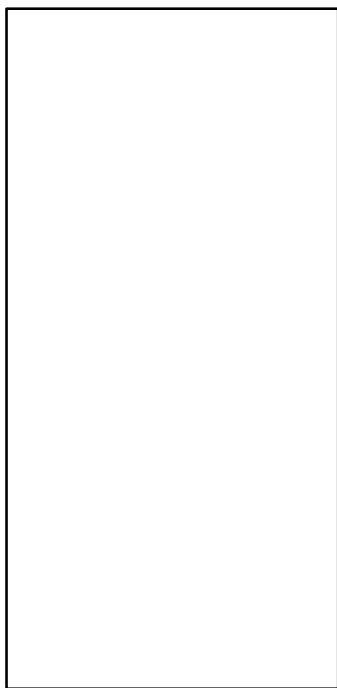

**Figure 21:1/8 DIN Panel Cutout Template**











## How to Contact Yokogawa Corporation of America

- For Sales and Technical Support please  
Call: (800) 888-6400 or (770) 254-0400  
Fax: (770) 251-2088  
Email: [meters-instr@us.yokogawa.com](mailto:meters-instr@us.yokogawa.com)
- For the latest version of this manual please visit  
[www.yokogawa-usa.com](http://www.yokogawa-usa.com)