

# YPP6060 Dual-Input Process Meter

## Instruction Manual



**PROPLUS**



- Dual Process Inputs with Math Functions
- Addition, Difference, Average, Multiplication, Division, Min, Max, Weighted Average, Ratio, Concentration, & More
- 0-20 mA, 4-20 mA, 0-5 V, 1-5 V, and  $\pm 10$  V Inputs
- NEMA 4X, IP65 Front
- Universal 85-265 VAC, or 12/24 VDC Input Power Models
- Large Dual-Line 6-Digit Display, 0.60" & 0.46"
- Isolated 24 VDC @ 200 mA Transmitter Power Supply
- Programmable Display & Function Keys
- 32-Point, Square Root, or Exponential Linearization
- Multi-Pump Alternation Control
- 2 or 4 Relays + Isolated 4-20 mA Output Options
- External 4-Relay & Digital I/O Expansion Modules
- USB, RS-232 & RS-485 Serial Communication Options
- Modbus<sup>®</sup> RTU Communication Protocol Standard
- Free **PROPLUS** Software for Operation, Monitoring, and Programming

**YOKOGAWA** ◆

2 Dart Road • Newnan, Georgia 30265  
770-253-7000 • 800-888-6400

Fax: 770-251-2088 • [www.yokogawa-usa.com](http://www.yokogawa-usa.com)

## Disclaimer

The information contained in this document is subject to change without notice. Yokogawa Corporation of America makes no representations or warranties with respect to the contents hereof and specifically disclaims any implied warranties of merchantability or fitness for a particular purpose.



**CAUTION:** Read complete instructions prior to installation and operation of the meter.



**WARNING:** Risk of electric shock or personal injury.



## Warning!

This product is not recommended for life support applications or applications where malfunctioning could result in personal injury or property loss. Anyone using this product for such applications does so at his/her own risk Yokogawa Corporation of America shall not be held liable for damages resulting from such improper use.

## Limited Warranty

Yokogawa Corporation of America warrants this product against defects in material or workmanship for the specified period under "Specifications" from the date of shipment from the factory. Yokogawa Corporation of America's liability under this limited warranty shall not exceed the purchase value, repair, or replacement of the defective unit.

## Registered Trademarks

All other trademarks mentioned in this document are the property of their respective owners.

© 2011 Yokogawa Corporation of America. All rights reserved.

[www.yokogawa-usa.com](http://www.yokogawa-usa.com)

## Table of Contents

<b>INTRODUCTION</b>	<b>6</b>
<b>ORDERING INFORMATION</b>	<b>7</b>
<b>SPECIFICATIONS</b>	<b>8</b>
General	8
Dual Process Input	10
Relays	11
Isolated 4-20 mA Transmitter Output	12
Modbus® RTU Serial Communications	13
YPPA1044 Digital Input & Output Expansion Module	13
<b>COMPLIANCE INFORMATION</b>	<b>14</b>
Safety	14
Electromagnetic Compatibility	14
<b>SAFETY INFORMATION</b>	<b>15</b>
<b>INSTALLATION</b>	<b>16</b>
Unpacking	16
Panel Mounting Instructions	16
Configuration for 12 or 24 VDC Power Option	17
Transmitter Supply Voltage Selection (P+, P-)	18
Connections	18
Connectors Labeling	19
Power Connections	19
Signal Connections	20
Modbus RTU Serial Communications	21
Relay Connections	21
Switching Inductive Loads	22
F4 Digital Input Connections	23
4-20 mA Output Connections	23
Analog Output Transmitter Power Supply	23
External Relays & Digital I/O Connections	24
Interlock Relay Feature	25
<b>SETUP AND PROGRAMMING</b>	<b>26</b>
Front Panel Buttons and Status LED Indicators	27
Display Functions & Messages	28
Main Menu	33
Setting Numeric Values	34
Reset Menu (rE5Et)	34

<b>Control Menu (Control)</b> -----	<b>34</b>
<b>Setting Up the Meter (SETUP)</b> -----	<b>35</b>
Setting the Input Signal (INPUT)-----	36
Setting the Decimal Point (DEC PT)-----	36
Programming the Meter (PRG)-----	37
Multi-Point Calibration & Scaling-----	38
<b>PROPLUS</b> Software-----	38
Scaling the Meter without a Signal Source-----	38
Scaling the Meter for Channel A (SCALE A)-----	39
Scaling the Meter for Channel B (SCALE b)-----	39
Calibrating the Meter with External Source-----	40
Calibrating the Meter for Channel A (CAL -A)-----	41
Calibrating the Meter for Channel B (CAL -b)-----	41
Setting the Display Parameter & Intensity (DISPLAY)-----	42
Display Setup Menu-----	43
Character Set for Engineering Units Display (d unit)-----	44
<b>Setting the Relay Operation (RELAY)</b> -----	<b>45</b>
Setting the Relay Assignment (RSSIGN)-----	46
Setting the Relay Action-----	47
Programming Set and Reset Points-----	48
Setting Fail-Safe Operation-----	48
Programming Time Delay-----	48
Relay Action for Loss of 4-20 mA Input (Loop Break)-----	48
<b>Relay and Alarm Operation Diagrams</b> -----	<b>49</b>
High Alarm Operation (Set > Reset)-----	49
Low Alarm Operation (Set < Reset)-----	50
High Alarm with Fail-Safe Operation (Set > Reset)-----	51
Low Alarm with Fail-Safe Operation (Set < Reset)-----	52
Pump Alternation Control Operation-----	53
Relay Sampling Operation-----	54
Signal Loss or Loop Break Relay Operation-----	55
Time Delay Operation-----	56
<b>Relay Operation Details</b> -----	<b>57</b>
Overview-----	57
Relays Auto Initialization-----	57
Fail-Safe Operation-----	57
Front Panel LEDs-----	58
Latching and Non-Latching Relay Operation-----	58
Non-Latching Relay (RLE)-----	59
Non-Latching Relay (R-n Rn)-----	59
Latching Relay (LLEH)-----	59
Latching Relay (L-LLR)-----	60

Acknowledging Relays -----	60
Pump Alternation Control Applications ( <i>RLtErn</i> ) -----	61
Setting Up the Interlock Relay (Force On) Feature -----	62
<b>Scaling the 4-20 mA Analog Output (<i>Rout</i>) -----</b>	<b>63</b>
<b>Setting Up the Password (<i>PR55</i>) -----</b>	<b>64</b>
Protecting or Locking the Meter -----	64
Making Changes to a Password Protected Meter -----	65
Disabling Password Protection -----	65
<b>Advanced Features Menu -----</b>	<b>66</b>
Advanced Features Menu & Display Messages -----	67
Noise Filter ( <i>FiltEr</i> ) -----	70
Noise Filter Bypass ( <i>bYP55</i> ) -----	71
Modbus RTU Serial Communications ( <i>SErRL</i> ) -----	72
Select Menu ( <i>SELEct</i> ) -----	72
Signal Input Conditioning ( <i>FuncEtn</i> ) -----	74
Low-Flow Cutoff ( <i>LwtoFF</i> ) -----	76
Analog Output Programming ( <i>RoutPr</i> ) -----	76
Programmable Function Keys User Menu ( <i>u5Er</i> ) -----	78
Tare ( <i>tArE R, tArE b</i> ) -----	80
Internal Calibration ( <i>iCAL</i> ) -----	80
Meter Copy Function ( <i>CoPy</i> ) -----	83
<b>METER OPERATION -----</b>	<b>85</b>
<b>Front Panel Buttons Operation -----</b>	<b>85</b>
<b>Function Keys Operation -----</b>	<b>85</b>
<b>F4 Operation -----</b>	<b>86</b>
<b>Maximum/Minimum Readings -----</b>	<b>86</b>
<b>TROUBLESHOOTING -----</b>	<b>87</b>
<b>Diagnosics Menu (<i>dRG</i>) -----</b>	<b>87</b>
Determining Software Version -----	87
<b>Reset Meter to Factory Defaults -----</b>	<b>88</b>
Factory Defaults & User Settings -----	89
<b>Troubleshooting Tips -----</b>	<b>93</b>
<b>Alphabetical List of Display Functions &amp; Messages -----</b>	<b>94</b>
<b>MOUNTING DIMENSIONS -----</b>	<b>99</b>

## Table of Figures

Figure 1. 1/8 DIN Panel Cutout Dimensions .....	16
Figure 2. Panel Mounting Details .....	17
Figure 3. Jumper Configuration for 12/24 VDC Power .....	17
Figure 4. Transmitter Supply Voltage Selection .....	18
Figure 5. Connector Labeling for Fully Loaded YPP6060 .....	19
Figure 6. Power Connections .....	19
Figure 7. Transmitters Powered by Internal Supply .....	20
Figure 8. Transmitter Powered by Ext. Supply or Self-Powered ....	20
Figure 9. Voltage Input Connections .....	21
Figure 10. Relay Connections .....	21
Figure 11. AC and DC Loads Protection.....	22
Figure 12. Low Voltage DC Loads Protection .....	22
Figure 13. F4 Digital Input Connections .....	23
Figure 14. 4-20 mA Output Connections .....	23
Figure 15. Expansion Modules & DIN Rail Mounting Kit.....	24
Figure 16. External Relays Module Connections.....	24
Figure 17. Digital I/O Module Connections.....	25
Figure 18. Interlock Connections .....	25
Figure 19. Acknowledge Relays w/Function Key or Digital Input ..	60
Figure 20. Meter Copy Connection .....	83
Figure 21. Meter Dimensions - Side View .....	99
Figure 22. Meter Dimensions - Top View.....	99
Figure 23. 1/8 DIN Panel Cutout Template.....	101

## INTRODUCTION

The **PROPLUS** YPP6060 is a multipurpose, easy to use digital dual-input process meter ideal for level, flow rate, temperature transmitter, or pressure transmitter applications. It accepts current and voltage signals (e.g. 4-20 mA, 0-10 V). Various math functions may be applied to the inputs including addition, difference, absolute difference, average, weighted average, multiplication, division, minimum, maximum, draw, ratio, and concentration. This is in addition to the signal input conditioning functions (linear, square root, programmable exponent, or round horizontal tank calculations).

The displays, relays, and the analog output may be assigned to input channels A or B, or math result channel C.

Three of the front panel buttons can be custom-programmed for a specific operation.

The basic model includes an isolated 24 VDC transmitter power supply that can be used to power the input transmitters or other devices. An additional isolated 24 VDC power supply is included with the 4-20 mA output option.

A fully loaded YPP6060 meter has the following: four SPDT relays, 4-20 mA output, and two 24 VDC power supplies. The YPP6060 capabilities may be enhanced by adding the following external expansion modules: four SPST relays –creating an eight-relay dual-input process meter, two digital I/O modules with four inputs and four outputs each, and serial communication adapters for use with **PROPLUS** or Modbus RTU.

## ORDERING INFORMATION

### Standard Models

85-265 VAC Model	12/24 VDC Model	Options Installed
YPP6060-6R0	YPP6060-7R0	No options
YPP6060-6R2	YPP6060-7R2	2 relays
YPP6060-6R3	YPP6060-7R3	4-20 mA output
YPP6060-6R4	YPP6060-7R4	4 relays
YPP6060-6R5	YPP6060-7R5	2 relays & 4-20 mA output
YPP6060-6R7	YPP6060-7R7	4 relays & 4-20 mA output

### SunBright Display Models

85-265 VAC Model	12/24 VDC Model	Options Installed
YPP6060-6H0	YPP6060-7H0	No options
YPP6060-6H2	YPP6060-7H2	2 relays
YPP6060-6H3	YPP6060-7H3	4-20 mA output
YPP6060-6H4	YPP6060-7H4	4 relays
YPP6060-6H5	YPP6060-7H5	2 relays & 4-20 mA output
YPP6060-6H7	YPP6060-7H7	4 relays & 4-20 mA output

### Accessories

Model	Description
YPPA1002	DIN rail mounting kit for two expansion modules
YPPA1004	4 SPST (Form A) relays
YPPA1044	4 digital inputs & 4 digital outputs (2 may be connected)
YPPA1200	Meter copy cable
YPPA1232	RS-232 serial adapter
YPPA1485	RS-485 serial adapter
YPPA7485-I	RS-232 to RS-422/485 isolated converter
YPPA7485-N	RS-232 to RS-422/485 non-isolated converter
YPPA8008	USB serial adapter
YPPA8232-N	USB to RS-232 non-isolated converter
YPPA8485-I	USB to RS-422/485 isolated converter
YPPA8485-N	USB to RS-422/485 non-isolated converter
YPPX6901	Suppressor (snubber): 0.01 $\mu$ F/470 $\Omega$ , 250 VAC

## SPECIFICATIONS

*Except where noted all specifications apply to operation at +25°C.*

### General

<b>DISPLAY</b>	Main (big) display: 0.60" (15 mm) high, red LEDs Second (little) display: 0.46" (12 mm) high, red LEDs 6 digits each (-99999 to 999999), with lead zero blanking
<b>DISPLAY INTENSITY</b>	Eight user selectable intensity levels
<b>DISPLAY UPDATE RATE</b>	5/second (200 ms)
<b>OVERRANGE</b>	Display flashes <b>999999</b>
<b>UNDERRANGE</b>	Display flashes <b>-99999</b>
<b>DISPLAY ASSIGNMENT</b>	The main (Big) and second (Little) displays may be assigned to process values for Channels A (Ch-A), B (Ch-B), or C (Ch-C), toggle between (Ch-A & Ch-B, Ch-A & Ch-C, Ch-B & Ch-C, and Ch-A, Ch-B, & Ch-C), toggle between Channel & units, show channel gross value (no tare) or toggle net (tare) and gross values, show relay set points, max & min values, or Modbus input. The second display may also be set to show engineering units or be off, with no display.
<b>PROGRAMMING METHODS</b>	Four front panel buttons, digital inputs, PC and <b>PROPLUS</b> software, Modbus registers, or cloning using Copy function.
<b>NOISE FILTER</b>	Programmable from 2 to 199 (0 will disable filter)
<b>FILTER BYPASS</b>	Programmable from 0.1 to 99.9% of calibrated span
<b>RECALIBRATION</b>	All ranges are calibrated at the factory. Recalibration is recommended at least every 12 months.
<b>MAX/MIN DISPLAY</b>	Max/min readings reached by the process are stored until reset by the user or until power to the meter is turned off.
<b>PASSWORD</b>	Three programmable passwords restrict modification of programmed settings. Pass 1: Allows use of function keys and digital inputs Pass 2: Allows use of function keys, digital inputs and editing set/reset points Pass 3: Restricts all programming, function keys, and digital inputs.
<b>NON-VOLATILE MEMORY</b>	All programmed settings are stored in non-volatile memory for a minimum of ten years if power is lost.
<b>POWER OPTIONS</b>	85-265 VAC 50/60 Hz, 90-265 VDC, 20 W max or jumper selectable 12/24 VDC $\pm$ 10%, 15 W max



<b>FUSE</b>	Required external fuse: UL Recognized, 5 A max, slow blow; up to 6 meters may share one 5 A fuse
<b>ISOLATED TRANSMITTER POWER SUPPLY</b>	Terminals P+ & P-: 24 VDC $\pm$ 5% @ 200 mA max (standard), (12/24 VDC powered models rated @ 100 mA max). 5 or 10 VDC @ 50 mA max, selectable with internal jumper J4.
<b>NORMAL MODE REJECTION</b>	Greater than 60 dB at 50/60 Hz
<b>ISOLATION</b>	4 kV input/output-to-power line 500 V input-to-output or output-to-P+ supply
<b>OVERVOLTAGE CATEGORY</b>	Installation Overvoltage Category II: Local level with smaller transient overvoltages than Installation Overvoltage Category III.
<b>ENVIRONMENTAL</b>	Operating temperature range: -40 to 65°C Storage temperature range: -40 to 85°C Relative humidity: 0 to 90% non-condensing
<b>CONNECTIONS</b>	Removable screw terminal blocks accept 12 to 22 AWG wire, RJ45 for external relays, digital I/O, and serial communication adapters.
<b>ENCLOSURE</b>	1/8 DIN, high impact plastic, UL 94V-0, color: black
<b>MOUNTING</b>	1/8 DIN panel cutout required: 3.622" x 1.772" (92 mm x 45 mm) Two panel mounting bracket assemblies are provided.
<b>TIGHTENING TORQUE</b>	Screw terminal connectors: 5 lb-in (0.56 Nm)
<b>OVERALL DIMENSIONS</b>	4.68" x 2.45" x 5.64" (119 mm x 62 mm x 143 mm) (W x H x D)
<b>WEIGHT</b>	9.5 oz (269 g)
<b>WARRANTY</b>	3 years parts & labor

## Dual Process Input

<b>TWO INPUTS</b>	Two inputs, each separately field selectable: 0-20, 4-20 mA, $\pm 10$ V (0-5, 1-5, 0-10 V), Modbus PV (Slave)		
<b>CHANNELS</b>	Channel A, Channel B, Channel C (Math channel)		
<b>PROGRAMMABLE CONSTANTS</b>	Constant P (Adder): -99999 to 999999, default: 0.000 Constant F (Factor): 0.00001 to 999999, default: 1.000		
<b>MATH FUNCTIONS</b>	Name	Function	Setting
	Addition	$(A+B+P)*F$	5תטט
	Difference	$(A-B+P)*F$	d f
	Absolute diff.	$((\text{Abs}(A-B))+P)*F$	d fRb5
	Average	$((A+B)/2+P)*F$	Rb5
	Multiplication	$(A*B+P)*F$	תטטL
	Divide	$((A/B)+P)*F$	d fE
	Max of A or B	$((AB\text{-Hi})+P)*F$	H f-Rb
	Min of A or B	$((AB\text{-Lo})+P)*F$	L f-Rb
	Draw	$((A/B)-1)*F$	d fRb
	Weighted avg.	$((B-A)*F)+A$	תטטRb
	Ratio	$(A/B)*F$	fRb
	Concentration	$(A/(A+B))*F$	L fRb

Note: The F constant can be any value from 0.00001 to 999999. If the value is less than 1, it will have the same effect as a divider. For example, the average could also be derived by using  $(A+B)*F$ , where  $F = 0.500$ .

<b>SEQUENCE OF OPERATIONS FOR INPUT PROGRAMMING</b>	<ol style="list-style-type: none"> <li>1. Select Input for A and B</li> <li>2. Set up the engineering units for A, B, and C</li> <li>3. Set up decimal point for A, B, and C</li> <li>4. Scale A &amp; B</li> <li>5. Set up the displays for A, B, or C</li> <li>6. Select the transfer function for A &amp; B (e.g. Linear)</li> <li>7. Select Math function for Channel C</li> <li>8. Program constants for Factor (F) and Adder (P).</li> <li>9. Program cutoff values for A and B</li> </ol>
<b>ACCURACY</b>	$\pm 0.03\%$ of calibrated span $\pm 1$ count, square root & programmable exponent accuracy range: 10-100% of calibrated span
<b>TEMPERATURE DRIFT</b>	0.005% of calibrated span/ $^{\circ}\text{C}$ max from 0 to 65 $^{\circ}\text{C}$ ambient, 0.01% of calibrated span/ $^{\circ}\text{C}$ max from -40 to 0 $^{\circ}\text{C}$ ambient
<b>SIGNAL INPUT CONDITIONING</b>	Linear, square root, programmable exponent, or round horizontal tank volume calculation

<b>MULTI-POINT LINEARIZATION</b>	2 to 32 points for channel A and B						
<b>PROGRAMMABLE EXPONENT</b>	1.0001 to 2.9999						
<b>LOW-FLOW CUTOFF</b>	0-999999 (0 disables cutoff function)						
<b>DECIMAL POINT</b>	Up to five decimal places or none: <i>d.ddddd, d.dddd, d.ddd, d.dd, d.d, or d</i>						
<b>CALIBRATION RANGE</b>	<table border="0"> <tr> <td>Input Range</td> <td>Minimum Span</td> </tr> <tr> <td>4-20 mA</td> <td>0.15 mA</td> </tr> <tr> <td>±10 V</td> <td>0.10 V</td> </tr> </table> <p>An error message will appear if the input 1 and input 2 signals are too close together.</p>	Input Range	Minimum Span	4-20 mA	0.15 mA	±10 V	0.10 V
Input Range	Minimum Span						
4-20 mA	0.15 mA						
±10 V	0.10 V						
<b>INPUT IMPEDANCE</b>	<p>Voltage ranges: greater than 500 k<math>\Omega</math></p> <p>Current ranges: 50 - 100 <math>\Omega</math> (depending on resettable fuse impedance)</p>						
<b>INPUT OVERLOAD</b>	Current input protected by resettable fuse, 30 VDC max. Fuse resets automatically after fault is removed.						
<b>F4 DIGITAL INPUT CONTACTS</b>	3.3 VDC on contact. Connect normally open contacts across F4 to COM.						
<b>F4 DIGITAL INPUT LOGIC LEVELS</b>	Logic High: 3 to 5 VDC Logic Low: 0 to 1.25 VDC						

## Relays

<b>RATING</b>	2 or 4 SPDT (Form C) internal and/or 4 SPST (Form A) external; rated 3 A @ 30 VDC and 125/250 VAC resistive load; 1/14 HP ( $\approx$ 50 W) @ 125/250 VAC for inductive loads
<b>NOISE SUPPRESSION</b>	Noise suppression is recommended for each relay contact switching inductive loads; see page 22 for details.
<b>DEADBAND</b>	0-100% of span, user programmable
<b>HIGH OR LOW ALARM</b>	User may program any alarm for high or low trip point. Unused alarm LEDs and relays may be disabled (turn off).
<b>RELAY OPERATION</b>	<p>Automatic (non-latching)</p> <p>Latching (requires manual acknowledge)</p> <p>Sampling (based on time)</p> <p>Pump alternation control (2 to 8 relays)</p> <p>Off (disable unused relays and enable Interlock feature)</p> <p>Manual on/off control mode</p>

<b>RELAY RESET</b>	User selectable via front panel buttons or digital inputs <ol style="list-style-type: none"> <li>Automatic reset only (non-latching), when the input passes the reset point.</li> <li>Automatic + manual reset at any time (non-latching)</li> <li>Manual reset only, at any time (latching)</li> <li>Manual reset only after alarm condition has cleared (L)</li> </ol> <i>Note: Front panel button or digital input may be assigned to acknowledge relays programmed for manual reset.</i>
<b>TIME DELAY</b>	0 to 999.9 seconds, on & off relay time delays Programmable and independent for each relay
<b>FAIL-SAFE OPERATION</b>	Programmable and independent for each relay. <i>Note: Relay coil is energized in non-alarm condition. In case of power failure, relay will go to alarm state.</i>
<b>AUTO INITIALIZATION</b>	When power is applied to the meter, relays will reflect the state of the input to the meter.

## Isolated 4-20 mA Transmitter Output

<b>OUTPUT SOURCE</b>	Process channel A, B, or C, max or min for channel A, B, or highest or lowest max or min of A and B, set points 1-8, Modbus input, or manual control mode		
<b>SCALING RANGE</b>	1.000 to 23.000 mA for any display range		
<b>CALIBRATION</b>	Factory calibrated: 4.000 to 20.000 = 4-20 mA output		
<b>ANALOG OUT PROGRAMMING</b>	23.000 mA maximum for all parameters: Overrange, underrange, max, min, and break		
<b>ACCURACY</b>	$\pm 0.1\%$ of span $\pm 0.004$ mA		
<b>TEMPERATURE DRIFT</b>	0.4 $\mu\text{A}/^\circ\text{C}$ max from 0 to 65 $^\circ\text{C}$ ambient, 0.8 $\mu\text{A}/^\circ\text{C}$ max from -40 to 0 $^\circ\text{C}$ ambient <i>Note: Analog output drift is separate from input drift.</i>		
<b>ISOLATED TRANSMITTER POWER SUPPLY</b>	Terminals I+ & R: 24 VDC $\pm 5\%$ @ 40 mA maximum; may be used to power the 4-20 mA output or other devices. Refer to Figure 5 on page 19 and Figure 14 on page 23.		
<b>EXTERNAL LOOP POWER SUPPLY</b>	35 VDC maximum		
<b>OUTPUT LOOP RESISTANCE</b>	Power supply	Minimum	Maximum
	24 VDC	10 $\Omega$	700 $\Omega$
	35 VDC (external)	100 $\Omega$	1200 $\Omega$

**Modbus® RTU Serial Communications**

<b>SLAVE ID</b>	1 – 247 (Meter address)
<b>BAUD RATE</b>	300 – 19,200 bps
<b>TRANSMIT TIME DELAY</b>	Programmable between 0 and 199 ms
<b>DATA</b>	8 bit (1 start bit, 1 or 2 stop bits)
<b>PARITY</b>	Even, Odd, or None with 1 or 2 stop bits
<b>BYTE-TO-BYTE TIMEOUT</b>	0.01 – 2.54 second
<b>TURN AROUND DELAY</b>	Less than 2 ms (fixed)

*Note: Refer to the **PROPLUS** Modbus Register Tables located at [www.yokogawa-usa.com](http://www.yokogawa-usa.com) for details.*

**YPPA1044 Digital Input & Output Expansion Module**

<b>CHANNELS</b>	4 digital inputs & 4 digital outputs per module
<b>SYSTEM</b>	Up to 2 modules for a total of 8 inputs & 8 outputs
<b>DIGITAL INPUT LOGIC HIGH</b>	3 to 5 VDC
<b>DIGITAL INPUT LOGIC LOW</b>	0 to 1.25 VDC
<b>DIGITAL OUTPUT LOGIC HIGH</b>	3.1 to 3.3 VDC
<b>DIGITAL OUTPUT LOGIC LOW</b>	0 to 0.4 VDC
<b>SOURCE CURRENT</b>	10 mA maximum output current
<b>SINK CURRENT</b>	1.5 mA minimum input current
<b>+5 V TERMINAL</b>	To be used as pull-up for digital inputs only. Connect normally open contacts across +5 V & DI 1-4.

## COMPLIANCE INFORMATION

### Safety

<b>UL &amp; c-UL LISTED</b>	USA & Canada UL 508 Industrial Control Equipment
<b>UL FILE NUMBER</b>	E348677
<b>FRONT PANEL</b>	UL Type 4X, NEMA 4X, IP65; panel gasket provided
<b>LOW VOLTAGE DIRECTIVE</b>	EN 61010-1:2001 Safety requirements for measurement, control, and laboratory use

### Electromagnetic Compatibility

<b>EMISSIONS</b>	EN 55022:2006/A1:2007 Class A ITE emissions requirements
Radiated Emissions	Class A
AC Mains Conducted Emissions	Class A
<b>IMMUNITY</b>	EN 61326-1:2006 Measurement, control, and laboratory equipment EN 61000-6-2:2005 EMC heavy industrial generic immunity standard
RFI - Amplitude Modulated	80 -1000 MHz 10 V/m 80% AM (1 kHz) 1.4 - 2.0 GHz 3 V/m 80% AM (1 kHz) 2.0 - 2.7 GHz 1 V/m 80% AM (1 kHz)
Electrical Fast Transients	±2kV AC mains, ±1kV other
Electrostatic Discharge	±4kV contact, ±8kV air
RFI - Conducted	10V, 0.15-80 MHz, 1kHz 80% AM
AC Surge	±2kV Common, ±1kV Differential
Surge	1KV (CM)
Power-Frequency Magnetic Field	3 A/m 70%V for 0.5 period
Voltage Dips	40%V for 5 & 50 periods 70%V for 25 periods
Voltage Interruptions	<5%V for 250 periods

**Note:**

Testing was conducted on YPP6000 meters installed through the covers of grounded metal enclosures with cable shields grounded at the point of entry representing installations designed to optimize EMC performance.

*Declaration of Conformity available at [www.yokogawa-usa.com](http://www.yokogawa-usa.com)*

**SAFETY INFORMATION**

**CAUTION:** Read complete instructions prior to installation and operation of the meter.



**WARNING:** Risk of electric shock or personal injury.

**WARNING!**

***Hazardous voltages exist within enclosure. Installation and service should be performed only by trained service personnel.***

## INSTALLATION

There is no need to remove the meter from its case to complete the installation, wiring, and setup of the meter for most applications.

Instructions are provided for setting up a 12/24 VDC powered meter to operate from 12 VDC and for changing the transmitter power supply to output 5 or 10 VDC instead of 24 VDC, see page 17.

## Unpacking

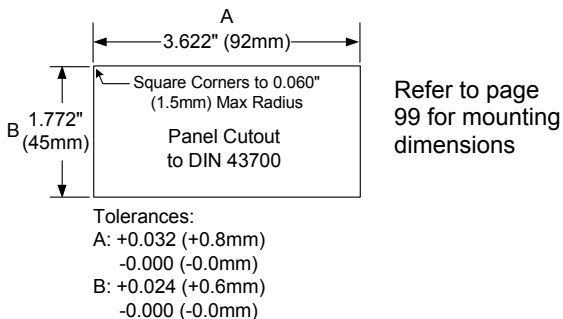
Remove the meter from box. Inspect the packaging and contents for damage. Report damages, if any, to the carrier.

If any part is missing or the meter malfunctions, please contact your supplier or the factory for assistance.

## Panel Mounting Instructions

- Prepare a standard 1/8 DIN panel cutout – 3.622" x 1.772" (92 mm x 45 mm). Refer to Figure 1 below, for more details.
- Clearance: allow at least 6.0" (152 mm) behind the panel for wiring.
- Panel thickness: 0.04" - 0.25" (1.0 mm - 6.4 mm).  
Recommended minimum panel thickness to maintain Type 4X rating: 0.06" (1.5 mm) steel panel, 0.16" (4.1 mm) plastic panel.
- Remove the two mounting brackets provided with the meter (back-off the two screws so that there is 1/4" (6.4 mm) or less through the bracket. Slide the bracket toward the front of the case and remove).
- Insert meter into the panel cutout.
- Install mounting brackets and tighten the screws against the panel. To achieve a proper seal, tighten the mounting bracket screws evenly until meter is snug to the panel along its short side. **DO NOT OVER TIGHTEN**, as the rear of the panel may be damaged.

**Note:** See Figure 23 on page 101 for 1/8 DIN Panel Cutout Template



**Figure 1. 1/8 DIN Panel Cutout Dimensions**



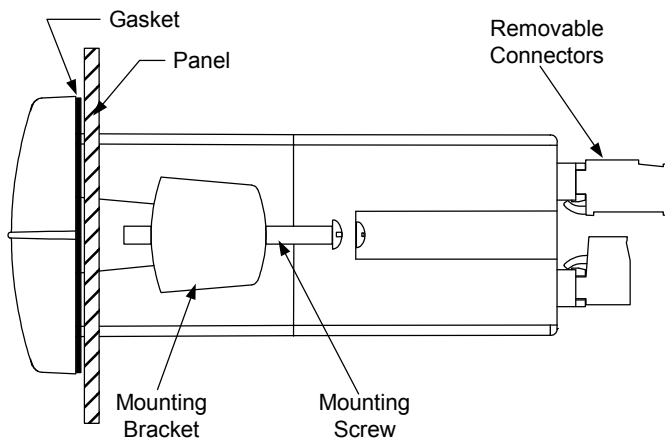


Figure 2. Panel Mounting Details

### Configuration for 12 or 24 VDC Power Option



Do not exceed voltage rating of the selected configuration.

Meters equipped with the 12/24 VDC power option are shipped from the factory ready to operate from 24 VDC.

To configure the meter for 12 VDC power:

1. Remove all the connectors.
2. Unscrew the back cover.
3. Slide the back cover about 1 inch.
4. Configure the J9 jumper, located behind the power connector, for 12 V as shown below.

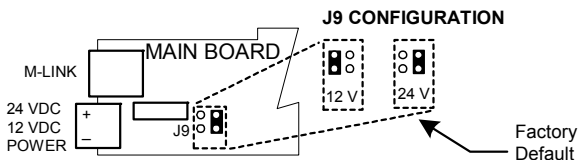


Figure 3. Jumper Configuration for 12/24 VDC Power

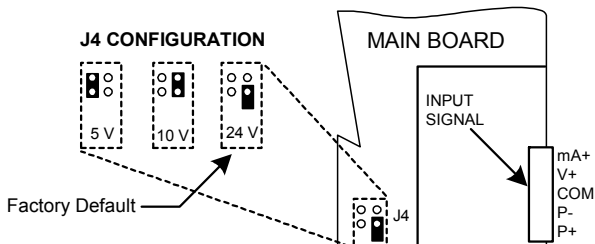
## Transmitter Supply Voltage Selection (P+, P-)

All meters, including models equipped with the 12/24 VDC power option, are shipped from the factory configured to provide 24 VDC power for the transmitter or sensor.

If the transmitter requires 5 or 10 VDC excitation, the internal jumper J4 must be configured accordingly.

To access the voltage selection jumper:

1. Remove all the wiring connectors.
2. Unscrew the back cover.
3. Slide out the back cover by about 1 inch.
4. Configure the J4 jumper, located behind the input signal connector, for the desired excitation voltage as shown.



**Figure 4. Transmitter Supply Voltage Selection**

## Connections

All connections are made to removable screw terminal connectors located at the rear of the meter.



Use copper wire with 60°C or 60/75°C insulation for all line voltage connections. Observe all safety regulations. Electrical wiring should be performed in accordance with all applicable national, state, and local codes to prevent damage to the meter and ensure personnel safety.

## Connectors Labeling

The connectors' label, affixed to the meter, shows the location of all connectors available with requested configuration.



### Warning!

Do not connect any equipment other than Yokogawa Corporation of America's expansion modules, cables, or meters to the RJ45 M-LINK connector. Otherwise damage will occur to the equipment and the meter.

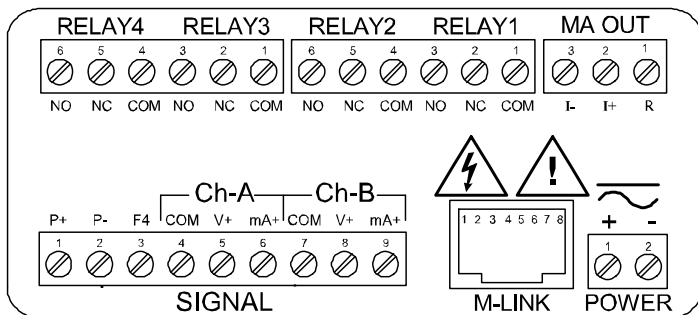
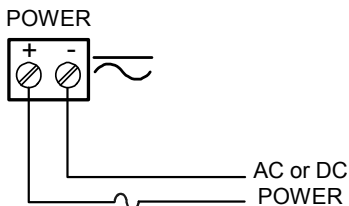


Figure 5. Connector Labeling for Fully Loaded YPP6060

## Power Connections

Power connections are made to a two-terminal connector labeled POWER on Figure 5. The meter will operate regardless of DC polarity connection. The + and - symbols are only a suggested wiring convention.



Required External Fuse:  
5 A max, 250 V Slow Blow

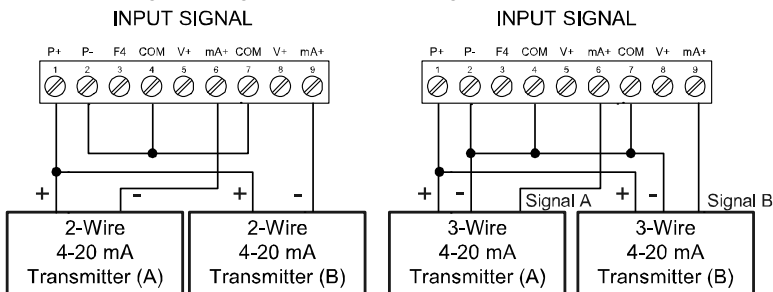
Figure 6. Power Connections

## Signal Connections

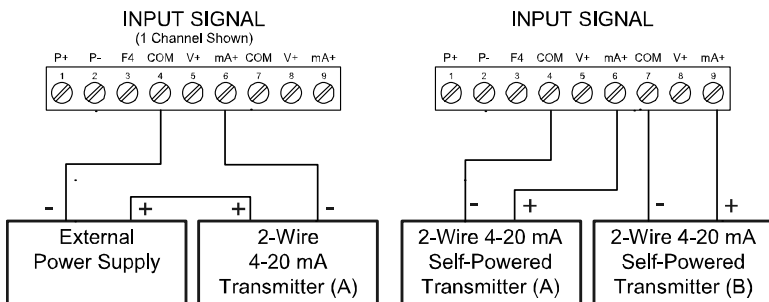
Signal connections are made to a nine-terminal connector labeled SIGNAL on Figure 5. The COM (common) terminal is the return for the 4-20 mA and the  $\pm 10$  V input signals.

### Current and Voltage Connections

The following figures show examples of current and voltage connections. There are no switches or jumpers to set up for current and voltage inputs. Setup and programming is performed through the front panel buttons.



**Figure 7. Transmitters Powered by Internal Supply**



**Figure 8. Transmitter Powered by Ext. Supply or Self-Powered**

The current input is protected against current overload by a resettable fuse. The display may or may not show a fault condition depending on the nature of the overload.

The fuse limits the current to a safe level when it detects a fault condition, and automatically resets itself when the fault condition is removed.

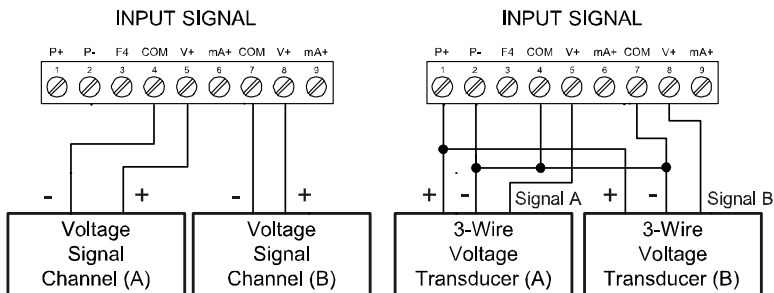


Figure 9. Voltage Input Connections

The meter is capable of accepting any voltage from -10 VDC to +10 VDC.

### Modbus RTU Serial Communications

Serial communications connection is made to an RJ45 connector labeled M-LINK on Figure 5. For interfacing to the **PROPLUS** use the YPPAA1232 for RS-232, the YPPAA1485 for RS-485, or the YPPA8008 for USB. The same port is used for interfacing with all expansion modules (e.g. external relays, digital I/O).

Use the YPPAA1200 meter copy cable for meter-to-meter interfacing for cloning purposes (i.e. copying settings from one meter to other meters).

### Relay Connections

Relay connections are made to two six-terminal connectors labeled RELAY1 – RELAY4 on Figure 5. Each relay's C terminal is common only to the normally open (NO) and normally closed (NC) contacts of the corresponding relay. The relays' C terminals should not be confused with the COM (common) terminal of the INPUT SIGNAL connector.

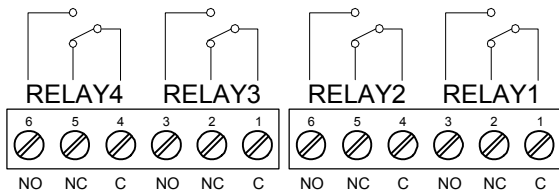
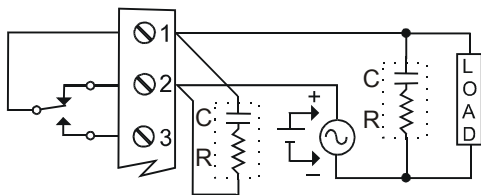


Figure 10. Relay Connections

## Switching Inductive Loads

The use of suppressors (snubbers) is strongly recommended when switching inductive loads to prevent disrupting the microprocessor's operation. The suppressors also prolong the life of the relay contacts. Suppression can be obtained with resistor-capacitor (RC) networks assembled by the user or purchased as complete assemblies. Refer to the following circuits for RC network assembly and installation:



**Figure 11. AC and DC Loads Protection**

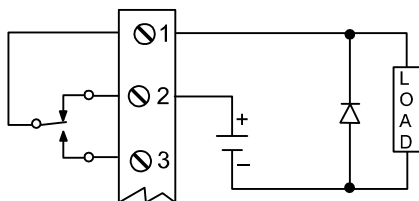
Choose R and C as follows:

R: 0.5 to 1  $\Omega$  for each volt across the contacts

C: 0.5 to 1  $\mu\text{F}$  for each amp through closed contacts

### Notes:

1. Use capacitors rated for 250 VAC.
2. RC networks may affect load release time of solenoid loads. Check to confirm proper operation.
3. Install the RC network at the meter's relay screw terminals. An RC network may also be installed across the load. Experiment for best results.



Use a diode with a reverse breakdown voltage two to three times the circuit voltage and forward current at least as large as the load current.

**Figure 12. Low Voltage DC Loads Protection**

**Note:** Relays are de-rated to 1/14th HP (50 watts) with an inductive load.

## F4 Digital Input Connections

A digital input, F4, is standard on the meter. This digital input connected with a normally open closure across F4 and COM, or with an active low signal applied to F4.

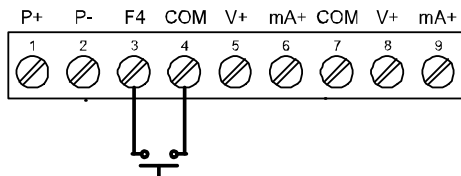


Figure 13. F4 Digital Input Connections

## 4-20 mA Output Connections

Connections for the 4-20 mA transmitter output are made to the connector terminals labeled MA OUT. The 4-20 mA output may be powered internally or from an external power supply.

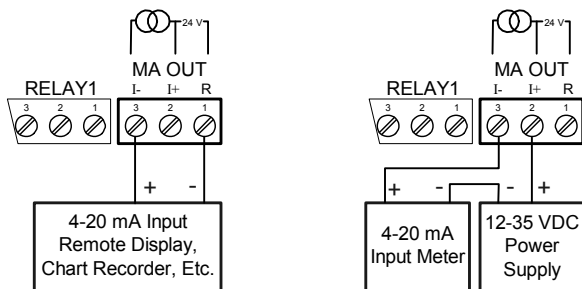


Figure 14. 4-20 mA Output Connections

## Analog Output Transmitter Power Supply

The internal 24 VDC power supply powering the analog output may be used to power other devices, if the analog output is not used. The I+ terminal is the +24 V and the R terminal is the return. This power supply is capable of sourcing up to 40 mA.

## External Relays & Digital I/O Connections

The relay and the digital I/O expansion modules YPPA1004 & YPPA1044 are connected to the meter using a CAT5 cable provided with each module. The two RJ45 connectors on the expansion modules are identical and interchangeable; they are used to connect additional modules to the system.

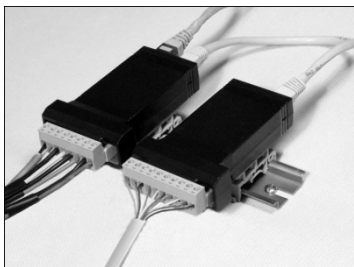
*Note: The jumper located between the RJ45 connectors of the YPPA1044 must be removed on the second digital I/O module in order for the system to recognize it as module #2.*



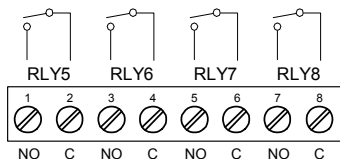
### Warning!

Do not connect or disconnect the expansion modules with the power on!

More detailed instructions are provided with each optional expansion module.

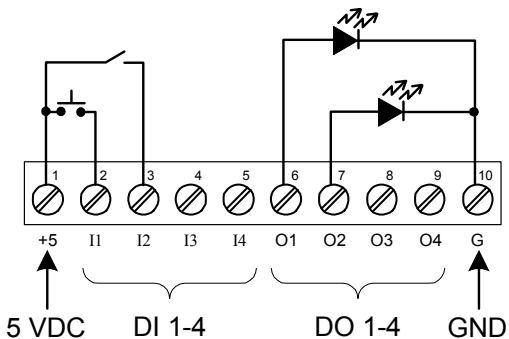


**Figure 15. Expansion Modules & DIN Rail Mounting Kit**



**Figure 16. External Relays Module Connections**

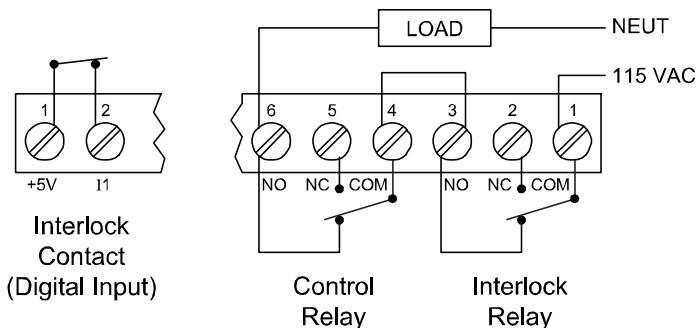




**Figure 17. Digital I/O Module Connections**

### Interlock Relay Feature

As the name implies, the interlock relay feature reassigns one, or more, alarm/control relays for use as interlock relay(s). Interlock contact(s) are wired to digital input(s) and trigger the interlock relay. This feature is enabled by configuring the relay, and relative digital input(s) (see page 62). In one example, dry interlock contacts are connected in series to one digital input which will be used to force on (energize) the assigned interlock power relay when all interlock contacts are closed (safe). The interlock relay front panel LED flashes when locked out. The interlock relay would be wired in-series with the load (N/O contact). See below.



**Figure 18. Interlock Connections**

## SETUP AND PROGRAMMING

The meter is factory calibrated prior to shipment to read in milliamps and volts depending on the input selection. The calibration equipment is certified to NIST standards.

### Overview





There are no jumpers to set for the meter input selection.

Setup and programming is done through the front panel buttons.

After power and input signal connections have been completed and verified, apply power to the meter.

## Front Panel Buttons and Status LED Indicators



Button Symbol	Description
	<b>Menu</b>
	<b>Right arrow/F1</b>
	<b>Up arrow/F2</b>
	<b>Enter/F3</b>
<b>Notes:</b> <i>F4 is a digital input. Alarms 5-8 are enabled when relay expansion module installed.</i>	

LED	Status
1-8	Alarm 1-8 indicator
1-8 M	Flashing: Relay in manual control mode
A B C	Flashing: Tare
1-4	Flashing: Relay interlock switch open
<b>Note:</b> <i>LEDs for relays in manual mode flash with the "M" LED every 10 seconds.</i>	

- Press the Menu button to enter or exit the Programming Mode at any time.
- Press the Right arrow button to move to the next digit during digit or decimal point programming.
- Press or hold the Up arrow button to scroll through the menus, decimal point, or to increment the value of a digit.
- Press the Enter button to access a menu or to accept a setting.
- Press and hold the Menu button for three seconds to access the advanced features of the meter.

## Display Functions & Messages

The meter displays various functions and messages during setup, programming, and operation. The following table shows the main menu functions and messages in the order they appear in the menu.

Display	Parameter	Action/Setting Description
rESEt	<i>Reset</i>	Press Enter to access the <i>Reset</i> menu
rSt Hi	<i>Reset high</i>	Press Enter to reset max display
rSt Lo	<i>Reset low</i>	Press Enter to reset min display
rSt HL	<i>Reset high &amp; low</i>	Press Enter to reset max & min displays
rSt tr	<i>Rest Tare</i>	Press Enter to reset (cancel) tare
Control	<i>Control</i>	Enter <i>Control</i> menu
Auto	<i>Automatic</i>	Press Enter to set meter for automatic operation
on An	<i>Manual</i>	Press Enter to manually control relays or analog output operation
SEtUP	<i>Setup</i>	Enter <i>Setup</i> menu
inPUt	<i>Input</i>	Enter <i>Input</i> selection menu
Ch-A	<i>Input</i>	Set input type for channel A
Ch-b	<i>Input</i>	Set input type for channel B
on R	<i>4-20 mA</i>	Set meter for 4-20 mA input
VolT	<i>0-10 VDC</i>	Set meter for ±10 VDC input
un it	<i>Unit</i>	Select the display units/tags
Ch-A	<i>Unit</i>	Set unit or tag for channel A
Ch-b	<i>Unit</i>	Set unit or tag for channel B
dEc Pt	<i>Decimal point</i>	Set decimal point
Ch-A	<i>Decimal point</i>	Set decimal point for channel A
Ch-b	<i>Decimal point</i>	Set decimal point for channel B
Ch-C	<i>Decimal point</i>	Set decimal point for channel C
PrOG	<i>Program</i>	Enter the <i>Program</i> menu
SCALE A	<i>Scale A</i>	Enter the <i>Scale</i> menu for channel A

Display	Parameter	Action/Setting Description
SCALE b	Scale B	Enter the <i>Scale</i> menu for channel B
CAL A	Calibrate A	Enter the <i>Calibration</i> menu for channel A
CAL b	Calibrate B	Enter the <i>Calibration</i> menu for channel B
INP 1	Input 1	Calibrate input 1 signal or program input 1 value
DIS 1	Display 1	Program display 1 value
INP 2	Input 2	Calibrate input 2 signal or program input 2 value (up to 32 points)
DIS 2	Display 2	Program display 2 value (up to 32 points)
Error	Error	Error, calibration not successful, check signal or programmed value
DISPLAY	Display	Enter the <i>Display</i> menu
b IG	Big display	Press Enter to assign the big display parameter (default: Ch-A)
L LITTLE	Little display	Press Enter to assign the little display parameter (default: Ch-B)
d CH-A	Display Ch-A	Assign display to channel A
d CH-B	Display Ch-B	Assign display to channel B
d CH-C	Display Ch-C	Assign display to channel C (math)
d AB	Display AB	Alternate display of channel A & B
d AC	Display AC	Alternate display of channel A & C
d BC	Display BC	Alternate display of channel B & C
d ABC	Display ABC	Alternate display of channel A, B, & C
d SET 1	Display Set 1	Displays relay 1 set point. Repeats for relays 1-8.
d HI-A	Display Hi A	Display high value of channel A
d LO-A	Display Lo A	Display low value of channel A
d HL-A	Display Hi/Low A	Alternate between high/low value of channel A
d HI-B	Display Hi B	Display high value of channel B
d LO-B	Display Lo B	Display low value of channel B

Display	Parameter	Action/Setting Description
d HL-b	Display Hi/Low B	Alternate between high/low value of channel B
d H i- $\bar{C}$	Display Hi C	Display high value of channel C
d Lo- $\bar{C}$	Display Lo C	Display low value of channel C
d HL- $\bar{C}$	Display Hi/Low C	Alternate between high/low value of channel C
d A-u	Display A and units/tags	Alternate display of channel A and the unit/tag
d B-u	Display B and units/tags	Alternate display of channel B and the unit/tag
d $\bar{C}$ -u	Display B and units/tags	Alternate display of channel C and the unit/tag
A Gross	Display A gross	Display input channel A gross (no tare)
A net- $\bar{G}$	Display A net and gross	Alternate display of channel A net (tare) and gross (no tare)
B Gross	Display B gross	Display input channel B gross (no tare)
B net- $\bar{G}$	Display B net and gross	Alternate display of channel B net (tare) and gross (no tare)
Modbus	Display Modbus	Display Modbus input register
d-Int $\bar{Y}$	Display intensity	Set display intensity level from 1 to 8
RELAY	Relay	Enter the Relay menu
ASSIGN	Assignment	Assign relays to channels or Modbus
ASSIGN 1	Assign 1	Relay 1 assignment
h-A	Channel A	Assign relay to channel A
h-b	Channel B	Assign relay to channel B
h- $\bar{C}$	Channel C	Assign relay to channel C (math channel)
Modbus	Modbus	Assign relay to Modbus register
RELAY 1	Relay 1	Relay 1 setup
Relay 1	Action 1	Set relay 1 action
Auto	Automatic	Set relay for automatic reset
A-Manual	Auto-manual	Set relay for auto or manual reset any time

Display	Parameter	Action/Setting Description
LRLCH	Latching	Set relay for latching operation
Lt-Clr	Latching-cleared	Set relay for latching operation with manual reset only after alarm condition has cleared
ALtern	Alternate	Set relay for pump alternation control
SRn PL	Sample	Set relay for sample time trigger control
OFF	Off	Turn relay off
FRILSF	Fail-safe	Enter <i>Fail-safe</i> menu
FLS 1	Fail-safe 1	Set relay 1 fail-safe operation
On	On	Enable fail-safe operation
FLS 2	Fail-safe 2	Set relays 2-8 fail-safe operation
dELAY	Delay	Enter relay <i>Time Delay</i> menu
dLY 1	Delay 1	Enter relay 1 time delay setup
On 1	On 1	Set relay 1 On time delay
OFF 1	Off 1	Set relay 1 Off time delay
dLY 2	Delay 2	Enter relays 2-8 time delay setup
brEAK	Loop break	Set relay condition if loop break detected
Ignore	Ignore	Ignore loop break condition (Processed as a low signal condition)
On	On	Relay goes to alarm condition when loop break detected
OFF	Off	Relay goes to non-alarm condition when loop break detected
Rout	Analog output	Enter the <i>Analog output</i> scaling menu
dIS 1	Display 1	Program display 1 value
Out 1	Output 1	Program output 1 value (e.g. 4.000 mA)
dIS 2	Display 2	Program display 2 value
Out 2	Output 2	Program output 2 value (e.g. 20.000 mA)
PASS	Password	Enter the <i>Password</i> menu
PASS 1	Password 1	Set or enter Password 1
PASS 2	Password 2	Set or enter Password 2

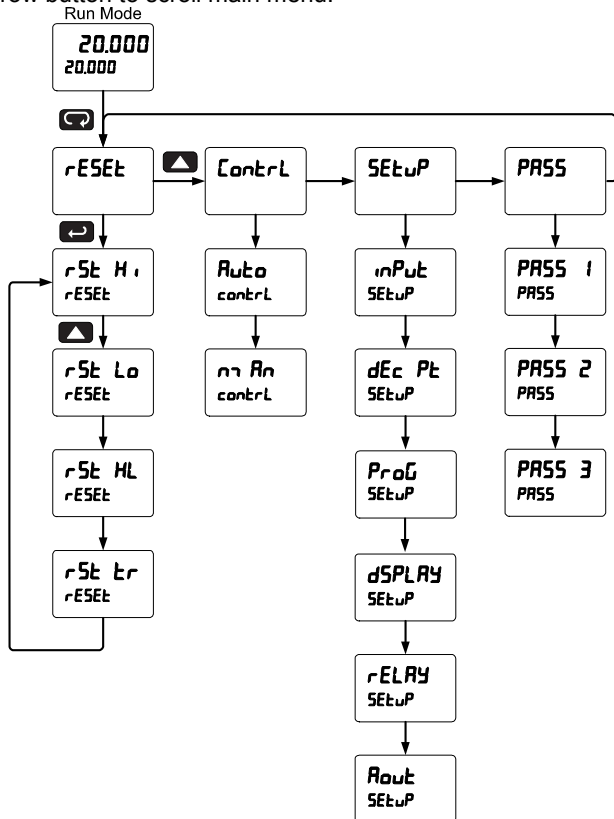
Display	Parameter	Action/Setting Description
<i>PR55 3</i>	<i>Password 3</i>	Set or enter Password 3
<i>unLac</i>	<i>Unlocked</i>	Program password to lock meter
<i>LacL</i>	<i>Locked</i>	Enter password to unlock meter
<i>999999</i> <i>-999999</i>	<i>Flashing</i>	Over/under range condition



## Main Menu

The main menu consists of the most commonly used functions: *Reset*, *Control*, *Setup*, and *Password*.

- Press Menu button to enter Programming Mode then press the Up arrow button to scroll main menu.



- Press Menu, at any time, to exit and return to Run Mode. Changes made to settings prior to pressing Enter are not saved.
- Changes to the settings are saved to memory only after pressing Enter.
- The display moves to the next menu every time a setting is accepted by pressing Enter.

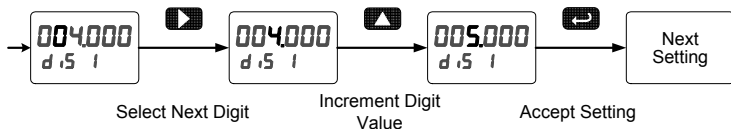
## Setting Numeric Values

The numeric values are set using the Right and Up arrow buttons. Press Right arrow to select next digit and Up arrow to increment digit value.

The digit being changed is displayed brighter than the rest.

Press and hold up arrow to auto-increment the display value.

Press the Enter button, at any time, to accept a setting or Menu button to exit without saving changes.

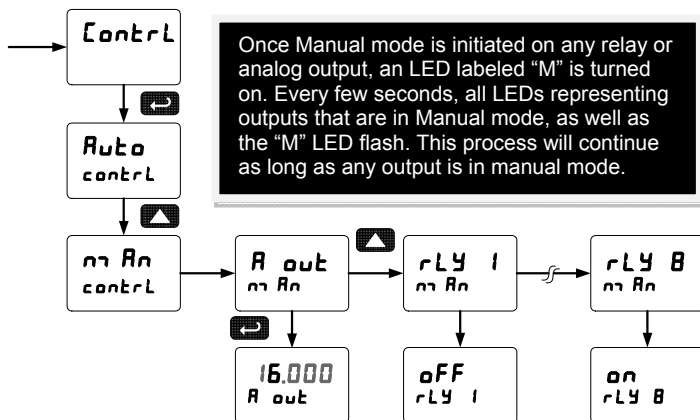


## Reset Menu (rESEt)

The *Reset* menu is used to reset the maximum or minimum reading (peak or valley) reached by the process; both may be reset at the same time by selecting “reset high & low” (r5t HL). The tare value used to zero the display may be reset by selecting “reset tare” (r5t tr).

## Control Menu (ContrL)

The *Control* menu is used to control the 4-20 mA analog output and the relays manually, ignoring the input. Each relay and analog output can be programmed independently for manual control. Selecting automatic control sets all relays and analog output for automatic operation.

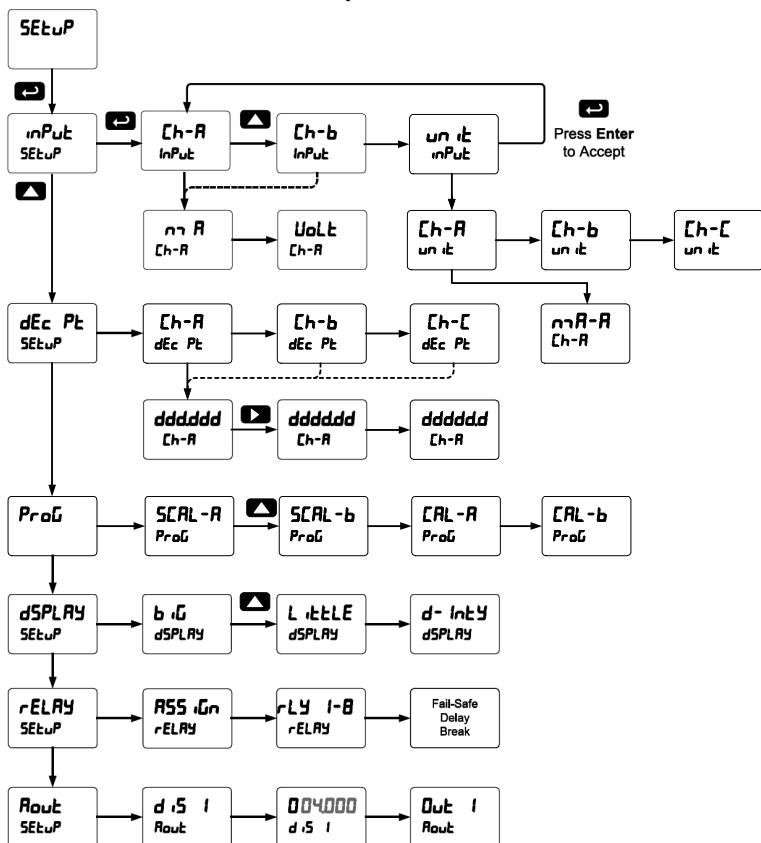


## Setting Up the Meter (SEtUP)

The *Setup* menu is used to select:

1. Input signal the meter will accept for channel A and channel B
2. Decimal point position for A, B, and C
3. Units for A, B, and C
4. Program the meter using the Scale or Calibrate functions
5. Display parameter and intensity
6. Relay assignment and operation
7. 4-20 mA analog output scaling

Press the Menu button to exit at any time.



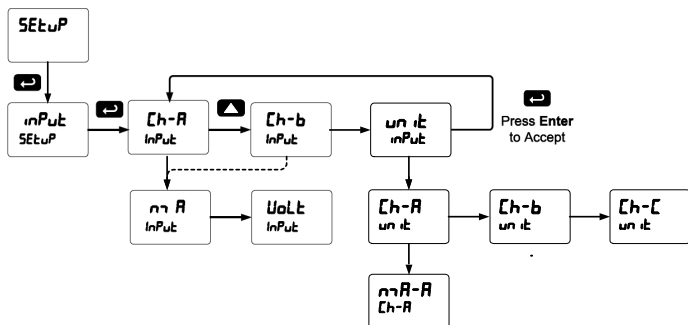
## Setting the Input Signal ( *inPut* )

Enter the *Input* menu to set up the meter to display current (*mA*) or voltage (*Volt*) inputs for channel A and channel B.

The current input is capable of accepting any signal from 0 to 20 mA. Select current input to accept 0-20 mA or 4-20 mA signals.

The voltage input is capable of accepting any signal from -10 to +10 VDC. Select voltage input to accept 0-5, 1-5, 0-10, or  $\pm 10$  VDC signals.

Channel C is the Math Function calculation, which is set up in the Advanced Features menu.



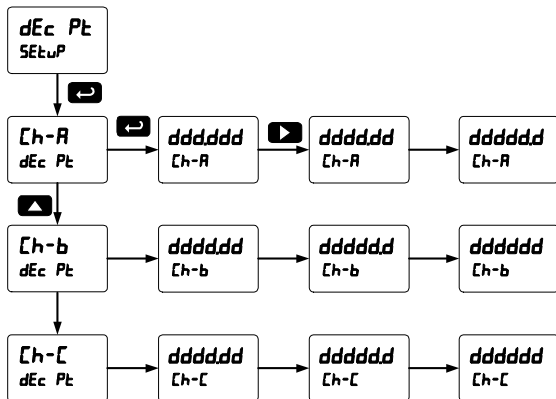
## Setting the Decimal Point ( *dEc Pt* )

The decimal point may be set with up to five decimal places or with no decimal point at all.

Pressing the Right arrow moves the decimal point one place to the right until no decimal point is displayed, and then it moves to the leftmost position.

There are three decimal points to set up for three channels: Ch-A, Ch-B, and Ch-C.

After the decimal points are set up, the meter moves to the *Program* menu.



## Programming the Meter (PrOg)

It is **very important** to read the following information, before proceeding to program the meter:

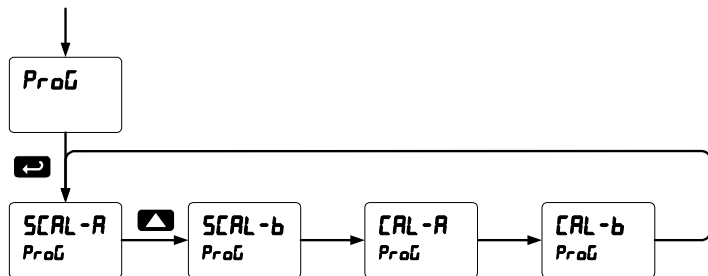
- The meter is factory calibrated prior to shipment to read in milliamps and volts depending on the input selection. The calibration equipment is certified to NIST standards.
- Use the *Scale* menu to scale the process input (e.g. 4-20 mA). A calibrated signal source is not needed to scale the meter.
- Use the *Calibrate* menu to apply a signal from a calibrator or a flowmeter.

The *Program* menu contains the *Scale* and the *Calibrate* menus for channels A & B.

The process inputs may be calibrated or scaled to any display value within the range of the meter.

**Note:** The *Scale* and *Calibrate* functions are exclusive of each other. The meter uses the last function programmed. Only one of these methods can be employed at a time. The *Scale* and *Calibrate* functions can use up to 32 points (default is 2). The number of points should be set in the *Advanced* menu under the *Multi-Point Linearization (L inERr)* menu selection prior to scaling and calibration of the meter, see page 75 for details.

The process inputs may be calibrated or scaled to any display value within the range of the meter.



Additional parameters, not needed for most applications, are programmed in the *Advanced Features* menu; see *Advanced Features Menu*, page 66.

### Multi-Point Calibration & Scaling

The meter is set up at the factory for 2-point linear calibration. The number of points for multi-point calibration/scaling is set up in the *Advanced Features* menu. Up to 32 linearization points may be selected. See page 75 for details.

### PROPLUS Software

The meter can also be programmed using the PC-based **PROPLUS** software available for free download at [www.yokogawa-usa.com](http://www.yokogawa-usa.com).

Data logging for one meter at the time is available with **PROPLUS** software. More advanced data acquisition may be accomplished by using any Modbus RTU compliant software.

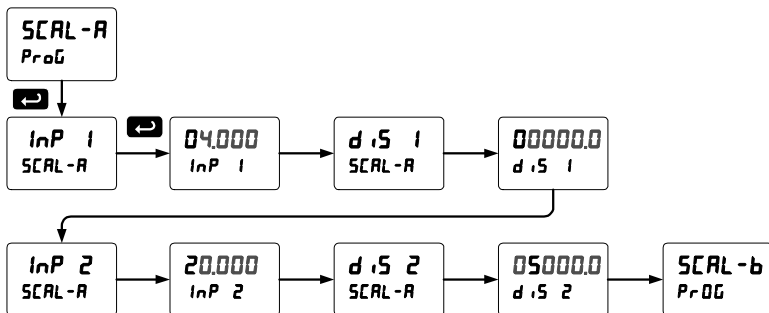
In order to program the meter using a computer, the meter must be connected using a USB, RS-232, or RS-485 serial adapter, see ORDERING INFORMATION on page 7 for details.

### Scaling the Meter without a Signal Source

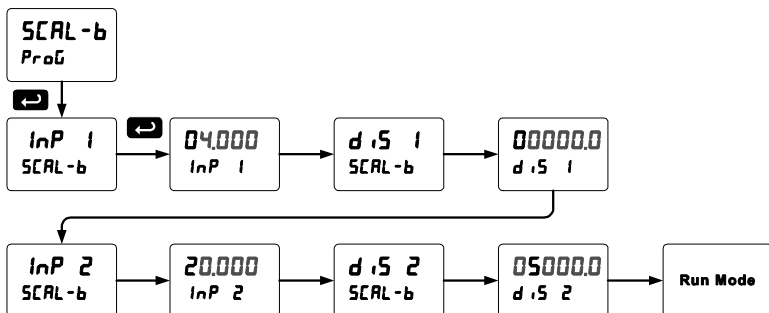
The process inputs (4-20 mA,  $\pm 10$  VDC) can be scaled to display the process variables in engineering units.

A signal source is not needed to scale the meter; simply program the inputs and corresponding display values.

## Scaling the Meter for Channel A (SCAL A)



## Scaling the Meter for Channel B (SCAL b)



For instructions on how to program numeric values see *Setting Numeric Values*, page 34.

**Error Message (Error)**

An error message indicates that the calibration or scaling process was not successful.

After the error message is displayed, the meter reverts to input 2 during calibration or scaling and to input 1 during internal calibration, allowing the appropriate input signal to be applied or programmed.

The error message might be caused by any of the following conditions:

1. Input signal is not connected to the proper terminals or it is connected backwards.
2. Wrong signal selection in *Setup* menu.
3. Minimum input span requirements not maintained.
4. Input 1 signal inadvertently applied to calibrate input 2.

### Minimum Input Span

The minimum input span is the minimum difference between input 1 and input 2 signals required to complete the calibration or scaling of the meter.

Input Range	Input 1 & Input 2 Span
4-20 mA	0.15 mA
±10 VDC	0.10 VDC

### Calibrating the Meter with External Source

To scale the meter without a signal source refer to Scaling **the Meter without a Signal Source**, page 38.

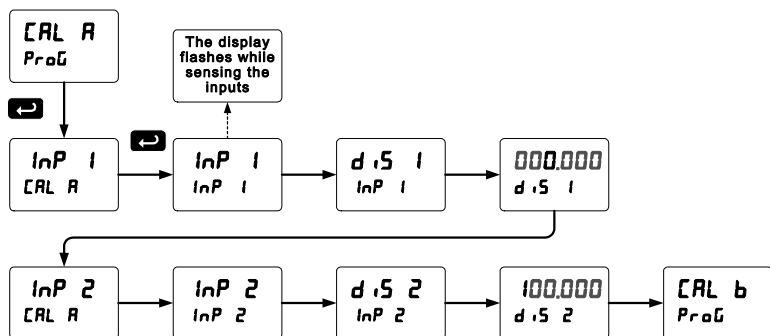
Warm up the meter for at least 15 minutes before performing calibration to ensure specified accuracy.

The meter can be calibrated to display the process variable in engineering units by applying the appropriate input signal and following the calibration procedure.

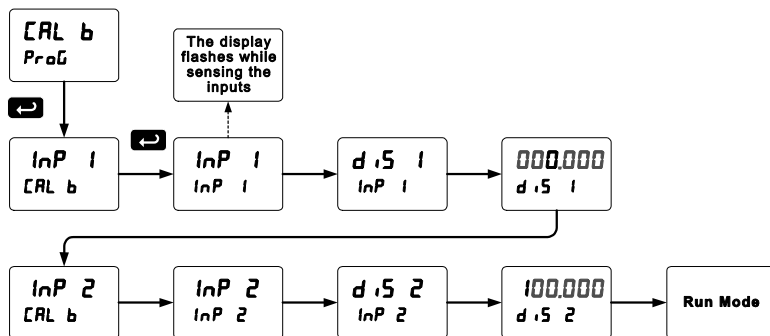
The use of a calibrated signal source is strongly recommended to calibrate the meter.



## Calibrating the Meter for Channel A (CAL -A)



## Calibrating the Meter for Channel B (CAL -b)



### Setting the Display Parameter & Intensity (dSPLY)

The main display (b 1) can be programmed to display:

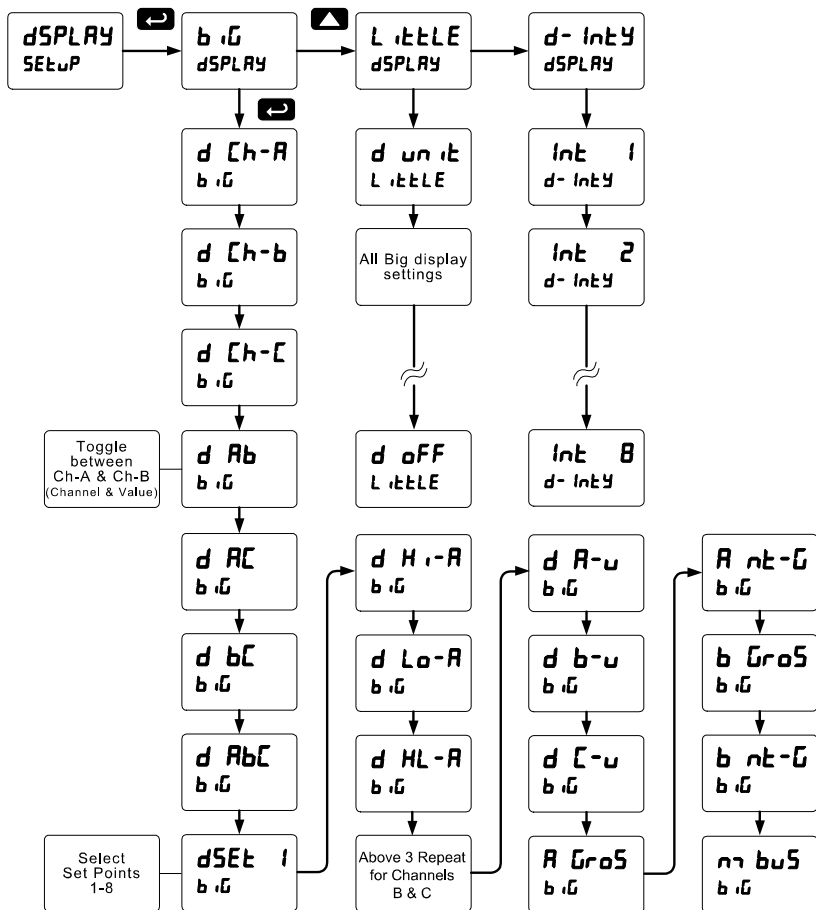
1. Process value Ch-A
2. Process value Ch-B
3. Process value Ch-C
4. Toggle between Ch-A & Ch-B, Ch-A & Ch-C, Ch-B & Ch-C, and Ch-A, Ch-B, & Ch-C
5. Toggle between Channel & units
6. Channel gross value (no tare) or toggle net (tare) and gross values
7. Relay set points
8. Max & min values for each channel
9. Modbus input

The small display (L 1111) can be programmed to display:

1. Process value Ch-A
2. Process value Ch-B
3. Process value Ch-C
4. Toggle between Ch-A & Ch-B, Ch-A & Ch-C, Ch-B & Ch-C, and Ch-A, Ch-B, & Ch-C
5. Toggle between Channel & units
6. Channel gross value (no tare) or toggle net (tare) and gross values
7. Relay set points
8. Max & min values for each channel
9. Engineering units or custom legends
10. Modbus input
11. Off (no display)

**Display Intensity:** The meter has eight display intensity levels to give the best performance under various lighting conditions. Select intensity 8 for outdoor applications.

### Display Setup Menu



After setting up the input and display, press the Menu button to exit programming and skip the rest of the setup menu.

The displays can be set up to read channels A, B, or C, toggle between A & B, B & C, A & C, A & B & C, toggle between channels A, B, or C & units, the max/min of any of the channels, including the math channel (C), set points, gross (without tare) or net (with tare) & gross values of channel A or B, or the Modbus input. In addition to the parameters

available on the Main display, the secondary display can display Engineering units or it could be turned off.

### Character Set for Engineering Units Display (د وحدة)

The small display can be programmed to show engineering units or custom legends using the following 7-segment character set:

Display	Character
0	0
1	1
2	2
3	3
4	4
5	5
6	6
7	7
8	8
9	9
A	A
b	b
C	C
c	c
d	d
E	E
F	F
G	G
g	g
H	H
h	h
l	l
i	i
J	J

Display	Character
K	K
L	L
m	m
n	n
O	O
o	o
P	P
q	q
r	r
S	S
t	t
u	u
V	V
w	w
X	X
Y	Y
Z	Z
-	-
/	/
]	]
[	[
=	=
	Space
°	°

\*Degree symbol (special non-ASCII character used)

The letters "m" and "w" use two 7-segment LEDs each; when selected the characters to the right are shifted one position.

See the flow chart on page 43 to access the display units menu. Units are edited for each applicable channel from within the *Setup* menu.

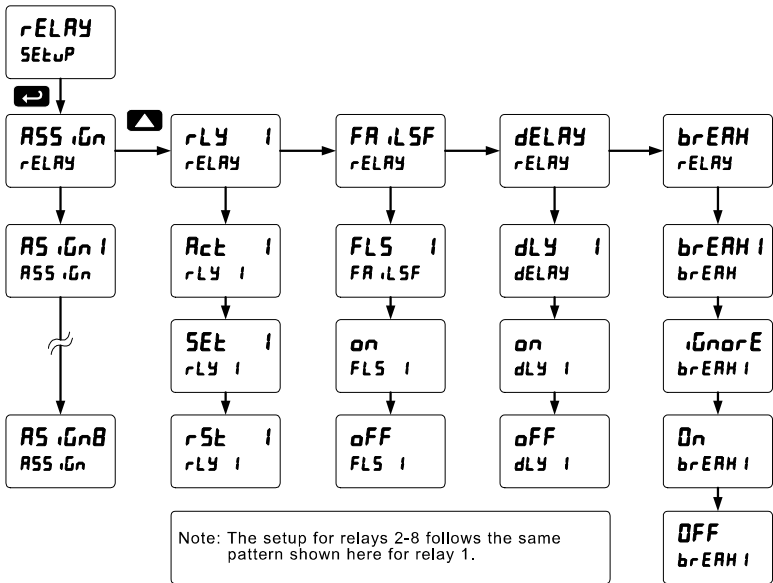
Press and hold up arrow to auto-scroll the characters in the display.

## Setting the Relay Operation (rELAY)

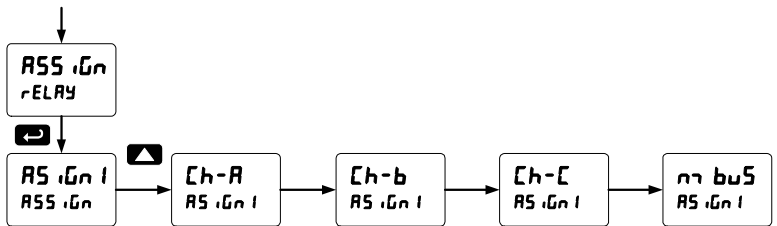
This menu is used to set up the assignment and operation of the relays.

*CAUTION! During setup, the relays do not follow the input and they will remain in the state found prior to entering the Relay menu.*

1. Relay assignment
  - a. Channel A
  - b. Channel B
  - c. Channel C (Math channel)
  - d. Modbus
2. Relay action
  - a. Automatic reset only (non-latching)
  - b. Automatic + manual reset at any time (non-latching)
  - c. Latching (manual reset only)
  - d. Latching with Clear (manual reset only after alarm condition has cleared)
  - e. Pump alternation control (automatic reset only)
  - f. Sampling (the relay is activated for a user-specified time)
  - g. Off (relay state controlled by Interlock feature)
3. Set point
4. Reset point
5. Fail-safe operation
  - a. On (enabled)
  - b. Off (disabled)
6. Time delay
  - a. On delay (0-999.9 seconds)
  - b. Off delay (0-999.9 seconds)
7. Relay action for loss (break) of 4-20 mA input (ignore, on, off)



### Setting the Relay Assignment (ASSIGN)

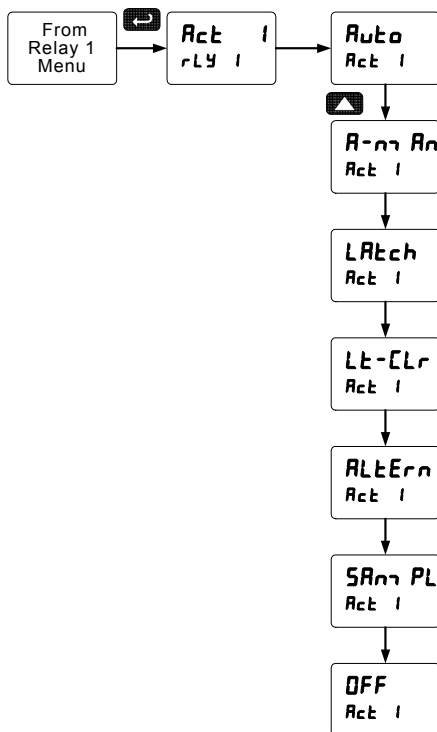


## Setting the Relay Action

Operation of the relays is programmed in the *Action* menu. The relays may be set up for any of the following modes of operation:

1. Automatic reset (non-latching)
2. Automatic + manual reset at any time (non-latching)
3. Latching (manual reset only, at any time)
4. Latching with Clear (manual reset only after alarm condition has cleared)
5. Pump alternation control (automatic reset only)
6. Sampling (the relay is activated for a user-specified time)
7. Off (relay state controlled by Interlock feature)

The following graphic shows relay 1 action setup; relay 2-8 are set up in a similar fashion.



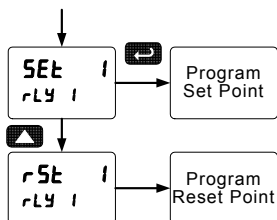
## Programming Set and Reset Points

High alarm indication: program set point above reset point.

Low alarm indication: program set point below reset point.

The deadband is determined by the difference between set and reset points. Minimum deadband is one display count. If the set and reset points are programmed with the same value, the relay will reset one count below the set point.

*Note: Changes are not saved until the reset point has been accepted.*



## Setting Fail-Safe Operation

In fail-safe mode of operation, the relay coil is energized when the process variable is within safe limits and the relay coil is de-energized when the alarm condition exists. The fail-safe operation is set independently for each relay. Select **on** to enable or select **off** to disable fail-safe operation.

## Programming Time Delay

The *On* and *Off* time delays may be programmed for each relay between 0 and 999.9 seconds. The relays will transfer only after the condition has been maintained for the corresponding time delay.

The *On* time delay is associated with the set point.

The *Off* time delay is associated with the reset point.

## Relay Action for Loss of 4-20 mA Input (Loop Break)

The loop break feature is associated with the 4-20 mA input. Each relay may be programmed to go to one of the following conditions when the meter detects the loss of the input signal (i.e. < 0.005 mA):

1. Turn *On* (Go to alarm condition)
2. Turn *Off* (Go to non-alarm condition)
3. Ignore (Processed as a low signal condition)

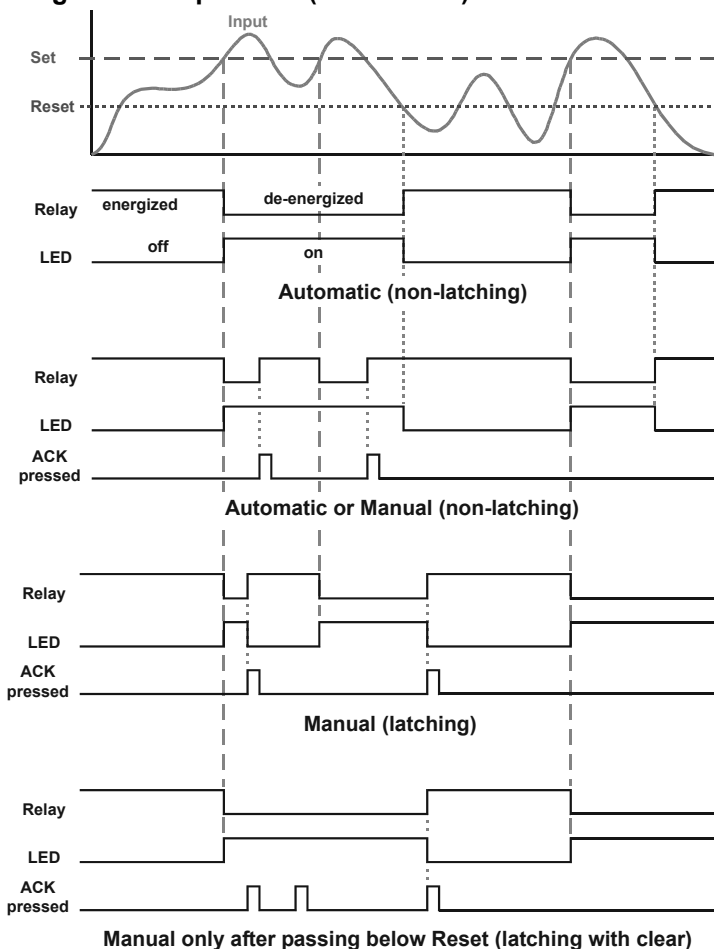
*Note: This is not a true loop break condition; if the signal drops below 0.005 mA, it is interpreted as a "loop break" condition.*



## Relay and Alarm Operation Diagrams

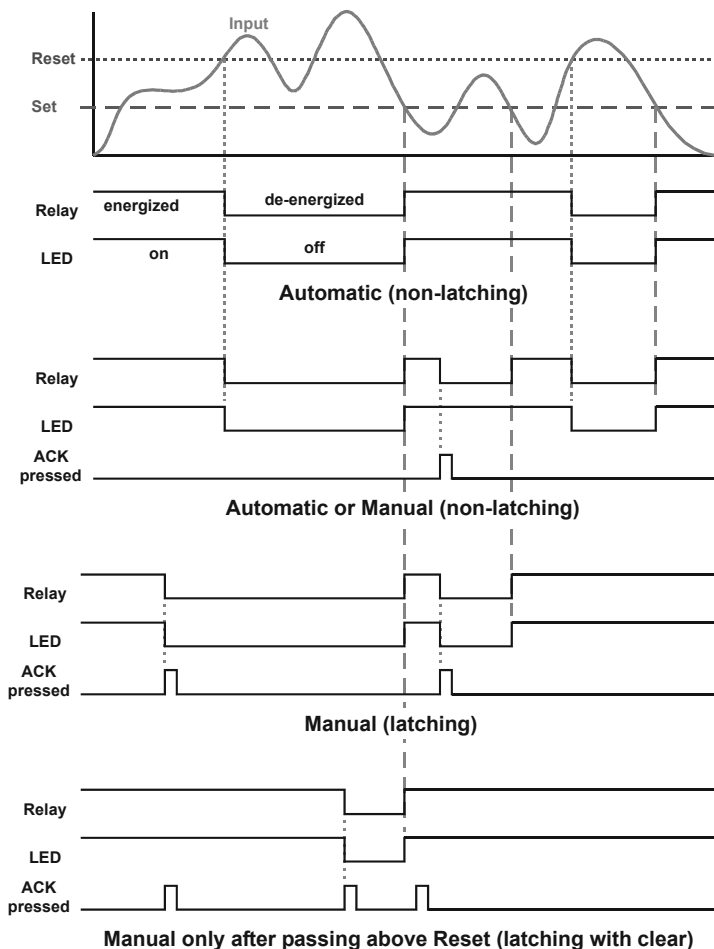
The following graphs illustrate the operation of the relays, status LEDs, and ACK button.

### High Alarm Operation (Set > Reset)



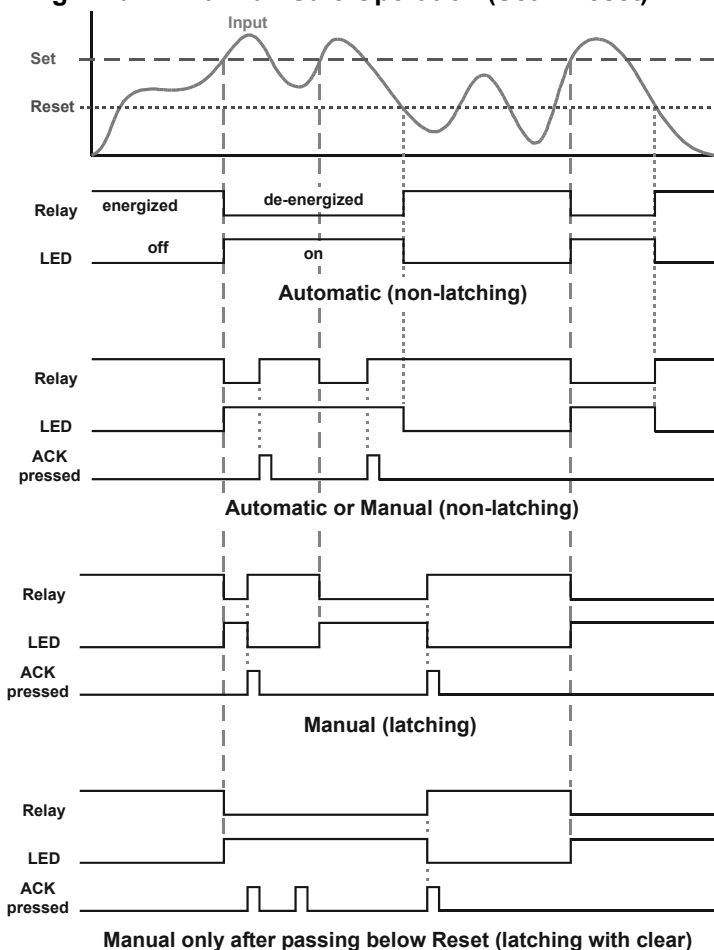
For Manual reset mode, ACK can be pressed anytime to turn "off" relay. To detect a new alarm condition, the signal must go below the set point, and then go above it.

### Low Alarm Operation (Set < Reset)



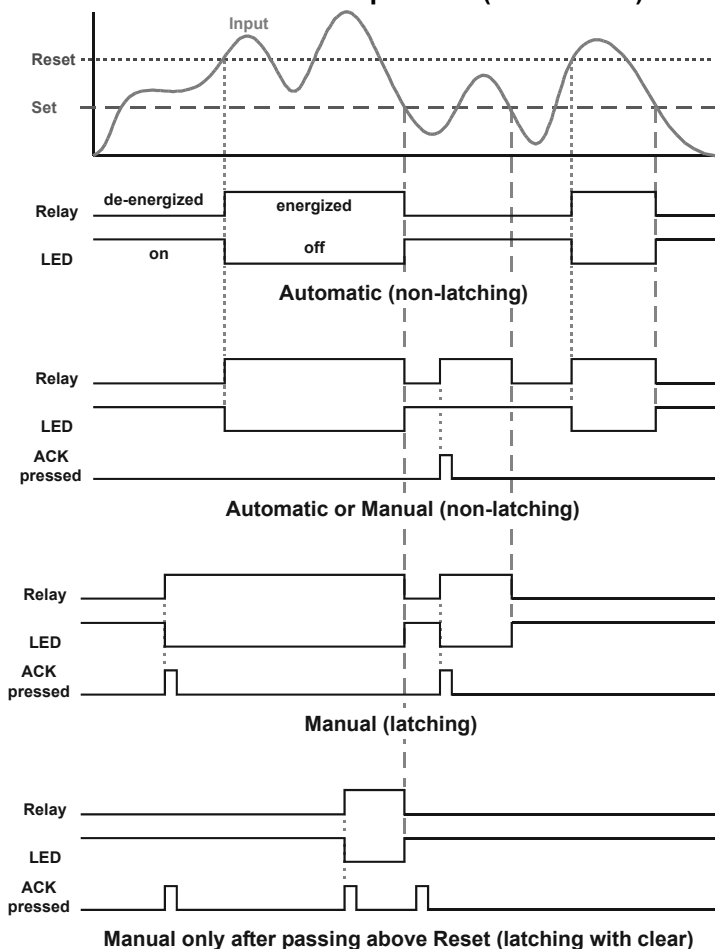
For Manual reset mode, ACK can be pressed anytime to turn "off" relay. For relay to turn back "on", signal must go above set point, and then go below it.

### High Alarm with Fail-Safe Operation (Set > Reset)



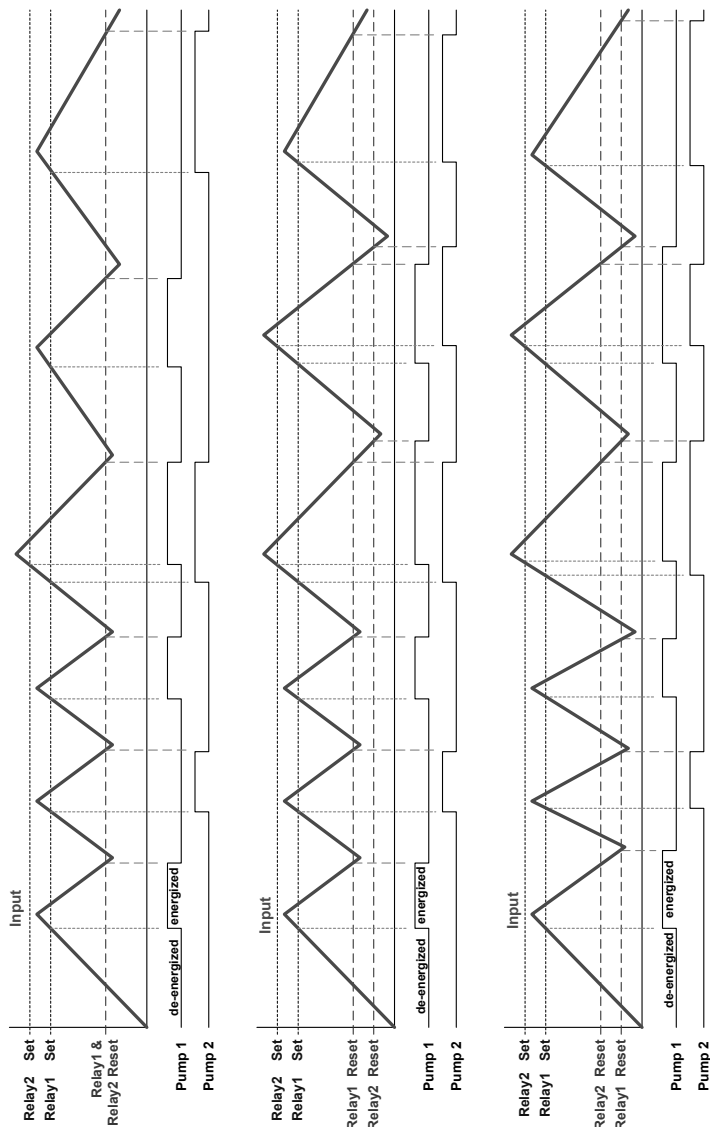
*Note: Relay coil is energized in non-alarm condition.  
In case of power failure, relay will go to alarm state.*

### Low Alarm with Fail-Safe Operation (Set < Reset)

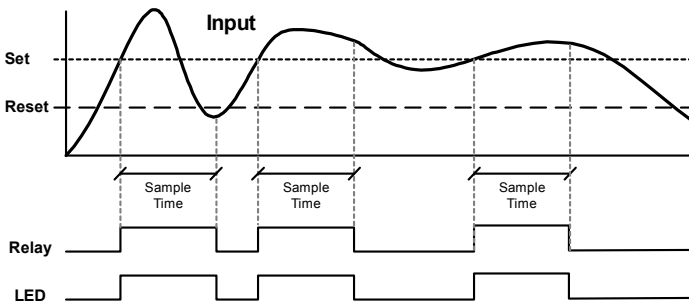


*Note: Relay coil is energized in non-alarm condition.  
In case of power failure, relay will go to alarm state.*

### Pump Alternation Control Operation



## Relay Sampling Operation

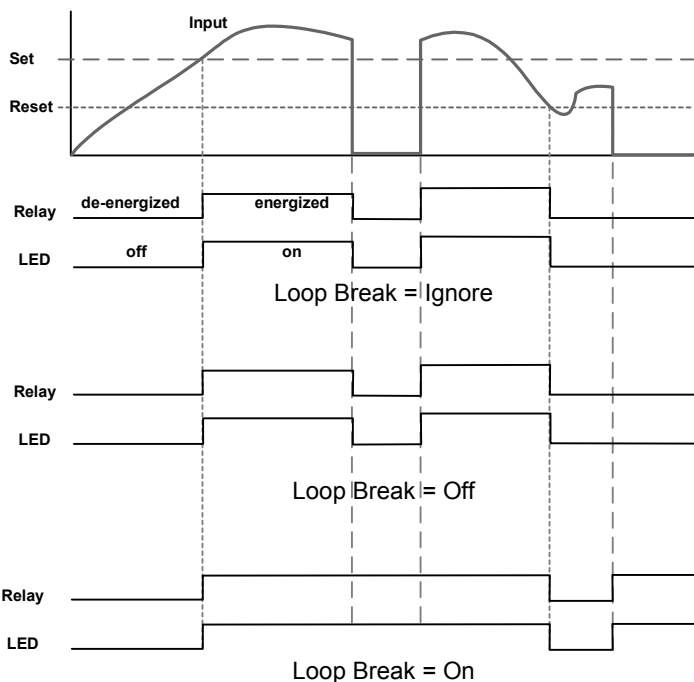


When the signal crosses the set point, the relay trips and the sample time starts. After the sample time has elapsed, the relay resets. The cycle repeats every time the set point is crossed, going up for high alarms and going down for low alarms.

The sample time can be programmed between 0.1 and 5999.9 seconds.

## Signal Loss or Loop Break Relay Operation

The following graph shows the loop break relay operation for a high alarm relay.

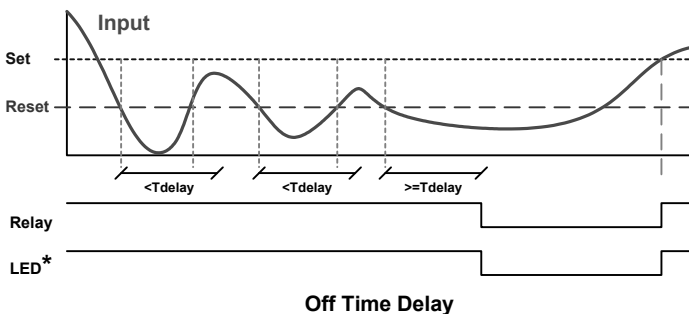
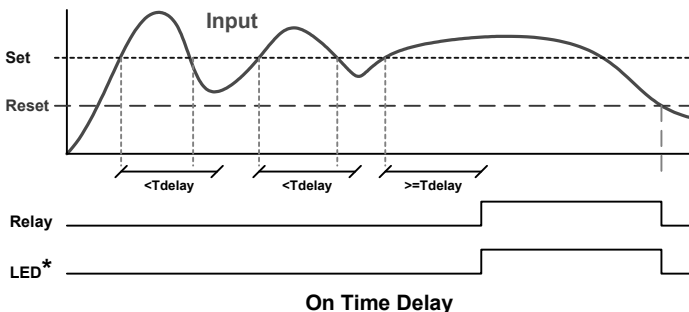


When the meter detects a break in the 4-20 mA loop, the relay will go to one of the following selected actions:

1. Turn *On* (Go to alarm condition)
2. Turn *Off* (Go to non-alarm condition)
3. Ignore (Processed as a low signal condition)

## Time Delay Operation

The following graphs show the operation of the time delay function.



When the signal crosses the set point, the *On* time delay timer starts and the relay trips when the time delay has elapsed. If the signal drops below the set point (high alarm) before the time delay has elapsed, the *On* time delay timer resets and the relay does not change state. The same principle applies to the *Off* time delay.

\* Note: If “Automatic or Manual (A-M) reset mode is selected, the LED follows the reset point and not the relay state when the relay is acknowledged.



## Relay Operation Details

### Overview

The relay capabilities of the meter expand its usefulness beyond simple indication to provide users with alarm and control functions. These capabilities include front panel alarm status LEDs as well as either 2 or 4 optional internal relays and/or 4 external relays expansion module. Typical applications include high or low temperature, level, pressure or flow alarms, control applications such as simple on/off pump control, and pump alternation control for up to 8 pumps. There are four basic ways the relays can be used:

1. High or Low Alarms with Latching or Non-Latching Relays
2. Simple On/Off Control with 100% Adjustable Deadband
3. Sampling (Based on Time)
4. Pump Alternation Control for up to 8 Pumps

### Relays Auto Initialization

When power is applied to the meter, the front panel LEDs and alarm relays will reflect the state of the input to the meter. The following table indicates how the alarm LEDs and relays will react on power-up based on the set and reset points:

Alarm #	HI or LO Alarm	Set Point	Reset Point	Power-Up Reading	Relay & LED
1	HI	1000	500	499	Off
2	LO	700	900	499	On
3	LO	250	400	499	Off
4	HI	450	200	499	On

### Fail-Safe Operation

The following table indicates how the relays behave based on the fail-safe selection for each relay:

Fail-Safe Selection	Non-Alarm State		Alarm State		Power Failure
	NO	NC	NO	NC	
Off	Open	Closed	Closed	Open	Relays go to non-alarm state
On	Closed	Open	Open	Closed	Relays go to alarm state

*Note: NO = Normally Open, NC = Normally Closed. This refers to the condition of the relay contacts when the power to the meter is off.*

## Front Panel LEDs

The LEDs on the front panel provide status indication for the following:

LED	Status
1	Alarm 1
2	Alarm 2
3	Alarm 3
4	Alarm 4

LED	Status
5	Alarm 5
6	Alarm 6
7	Alarm 7
8	Alarm 8

The meter is supplied with four alarm points that include front panel LEDs to indicate alarm conditions. This standard feature is particularly useful for alarm applications that require visual-only indication. The LEDs are controlled by the set and reset points programmed by the user. When the display reaches a set point for a high or low alarm, the corresponding alarm LED will turn on. When the display returns to the reset point the LED will go off. The front panel LEDs respond differently for latching and non-latching relays.

For non-latching relays, the LED is always off during normal condition and always on during alarm condition, regardless of the state of the relay (e.g. Relay acknowledged after alarm condition).

For latching relays, the alarm LEDs reflect the status of the relays, regardless of the alarm condition. The following tables illustrate how the alarm LEDs function in relation to the relays and the acknowledge button (Default: F3 key assigned to ACK):

### Latching and Non-Latching Relay Operation

The relays can be set up for latching (manual reset) or non-latching (automatic reset) operation.

#### Relay terminology for following tables

Terminology	Relay Condition
On	Alarm (Tripped)
Off	Normal (Reset)
Ack	Acknowledged

The On and Off terminology does not refer to the status of the relay's coil, which depends on the fail-safe mode selected.



In latching relay mode, latched relays will reset (unlatch) when power is cycled.

**Warning!**

**Non-Latching Relay (R<sub>u</sub>L<sub>o</sub>)****Automatic reset only**

Condition	LED	Relay
Normal	Off	Off
Alarm	On	On
Ack (No effect)	On	On
Normal	Off	Off

In this application, the meter is set up for automatic reset (non-latching relay). Acknowledging the alarm while it is still present has no effect on either the LED or the relay. When the alarm finally goes away, the relay automatically resets and the LED also goes off.

**Non-Latching Relay (R<sub>n</sub>-*n* R<sub>n</sub>)****Automatic + manual reset at any time**

Condition	LED	Relay
Normal	Off	Off
Alarm	On	On
Normal	Off	Off
Next Alarm	On	On
Ack	On	Off
Normal	Off	Off

In this application, the meter is set up for automatic and manual reset at any time (non-latching relay). The LED and the relay automatically reset when the meter returns to the normal condition.

The next time an alarm occurs, the operator acknowledges the alarm manually while the alarm condition still exists. This causes the relay to reset, but the LED stays on until the meter returns to the normal condition.

**Latching Relay (L<sub>R</sub>L<sub>o</sub>L<sub>H</sub>)****Manual reset any time**

Condition	LED	Relay
Normal	Off	Off
Alarm	On	On
Ack	Off	Off

In this application, the meter is set up for manual reset at any time. Acknowledging the alarm even if the alarm condition is still present resets the relay and turns off the LED.

## Latching Relay (L<sub>L</sub>-L<sub>r</sub>)

Manual reset only after alarm condition has cleared

Condition	LED	Relay
Normal	Off	Off
Alarm	On	On
Ack (No effect)	On	On
Normal	On	On
Ack	Off	Off

In this application, the meter is set up for manual reset only after the signal passes the reset point (alarm condition has cleared).

Acknowledging the alarm while it is still present has no effect on either the LED or the relay. When the alarm is acknowledged after it returns to the normal state, the LED and the relay go off. Notice that the LED remains on, even after the meter returns to the normal condition. This is because, for latching relays, the alarm LED reflects the status of the relay, regardless of the alarm condition.

### Acknowledging Relays

There are two ways to acknowledge relays programmed for manual reset: via the programmable front panel function keys F1-F3 (Default: F3 assigned to ACK) and remotely via a normally open pushbutton wired across one of the digital inputs and the +5 V terminals on the digital I/O modules (Default: DI-4 assigned to ACK). When the ACK button or the assigned digital input is closed, all relays programmed for manual reset are acknowledged.

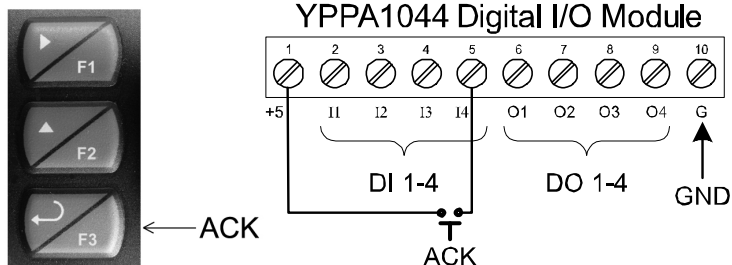


Figure 19. Acknowledge Relays w/Function Key or Digital Input

## Pump Alternation Control Applications (ALTErn)

For pump control applications where two or more similar pumps are used to control the level of a tank or a well, it is desirable to have all the pumps operate alternately. This prevents excessive wear and overheating of one pump over the lack of use of the other pumps.

Up to 8 relays can be set up to alternate every time an on/off pump cycle is completed. The set points and reset points can be programmed, so that the first pump on is the first pump off.

### Application #1: Pump Alternation Using Relays 1 & 2

1. Relays 1 and 2 are set up for pump alternation.
2. Relays 3 and 4 are set up for low and high alarm indication.

### Set and Reset Point Programming with Pump Alternation

Relay	Set Point	Reset Point	Function
1	30.000	10.000	Controls pump 1 & 2
2	35.000	5.000	Sets dual pump trigger
3	4.000	9.000	Controls low alarm
4	40.000	29.000	Controls high alarm

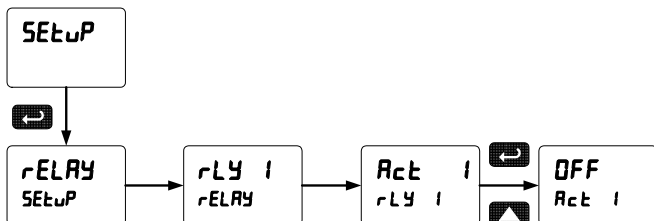
### Pump Alternation Operation

1. Pump #1 turns on when level reaches 30.000, when level drops below 10.000 pump #1 turns off.
2. The next time level reaches 30.000, pump #2 turns on, when level drops below 10.000 pump #2 turns off.
3. If the level doesn't reach 35.000 pump #1 and pump #2 will be operating alternately.
4. If pump #1 cannot keep the level below 35.000 pump #2 will turn on at 35.000, then as the level drops to 10.000 pump #1 turns off, pump #2 is still running and shuts off below 5.000.
5. Notice that with the set and reset points of pump #2 outside the range of pump #1, the first pump on is the first pump to go off. This is true for up to 8 alternating pumps, if setup accordingly.
6. Relay #3 will go into alarm if the level drops below 4.000 and relay #4 will go into alarm if the level exceeds 40.000.
7. Adding the 4 external relays expansion module allows using the 4 SPDT internal relays for pump alternation and the 4 SPST external relays for high, high-high, low, and low-low alarm indication.

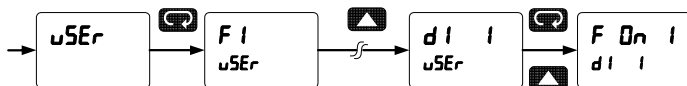
### Setting Up the Interlock Relay (Force On) Feature

Relays 1-4 can be set up as interlock relays. To set up the relays for the interlock feature:

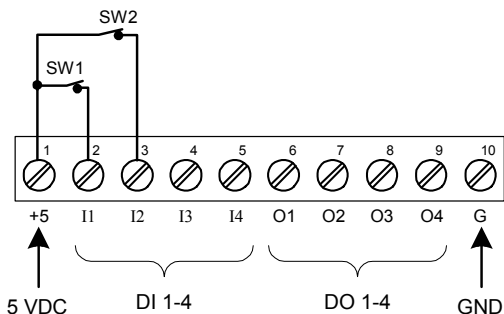
1. Access the *Setup – Relay – Action* menu and set the action to off.



2. In the *Advanced features – User* menu program any of the digital inputs to *Force On* any of the internal relays (1-4).



3. Connect a switch or dry contact between the +5V terminal and the corresponding digital input (dl-1 to dl-4) terminal.



### Interlock Relay Operation Example

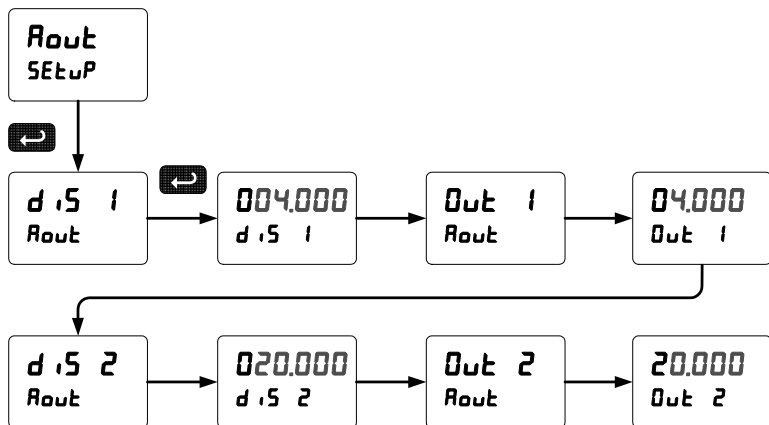
Relays 1 & 2 are configured to energize (their front panel LEDs are off) when SW1 & SW2 switches (above) are closed. If the contacts to these digital inputs are opened, the corresponding front panel LEDs flash indicating this condition. The processes being controlled by the interlock relay will stop, and will re-start only after the interlock relay is re-activated by the digital inputs (switches).

## Scaling the 4-20 mA Analog Output (*Rout*)

The 4-20 mA analog output can be scaled to provide a 4-20 mA signal for any display range selected.

No equipment is needed to scale the analog output; simply program the display values to the corresponding mA output signal.

The *Analog Output* menu is used to program the 4-20 mA output based on display values.



For instructions on how to program numeric values see *Setting Numeric Values*, page 34.

## Setting Up the Password (PASS)

The *Password* menu is used for programming three levels of security to prevent unauthorized changes to the programmed parameter settings.

Pass 1: Allows use of function keys and digital inputs

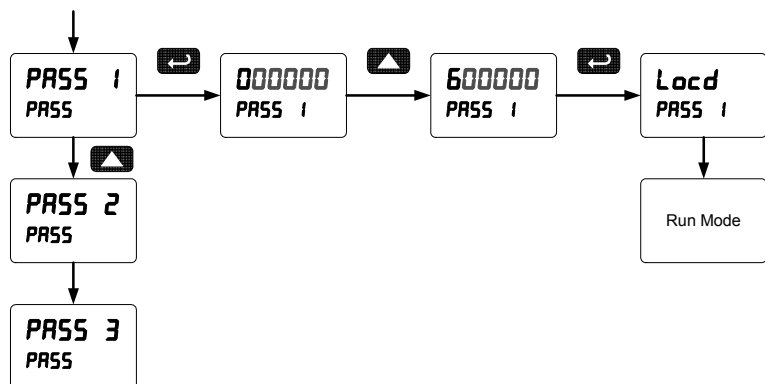
Pass 2: Allows use of function keys, digital inputs and editing set/reset points

Pass 3: Restricts all programming, function keys, and digital inputs.

### Protecting or Locking the Meter

Enter the *Password* menu and program a six-digit password.

For instructions on how to program numeric values see *Setting Numeric Values*, page 34.



Record the password for future reference. If appropriate, it may be recorded in the space provided.

Model:	
Serial Number:	
Password 1:	__ __ __ __ __ __
Password 2:	__ __ __ __ __ __
Password 3:	__ __ __ __ __ __

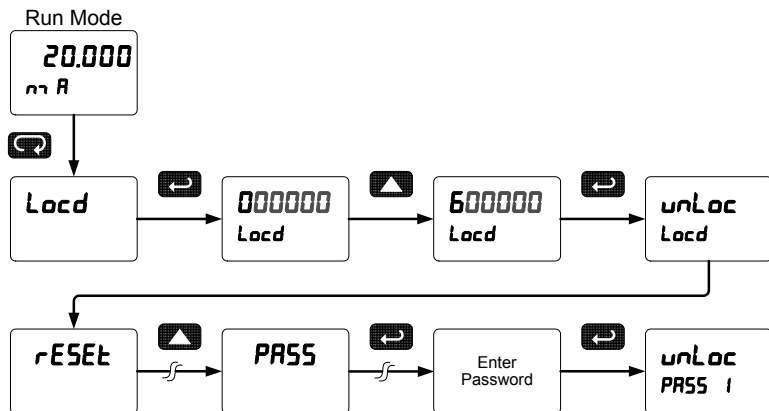


## Making Changes to a Password Protected Meter

If the meter is password protected, the meter will display the message *Locd* (*Locked*) when the Menu button is pressed. Press the Enter button while the message is being displayed and enter the correct password to gain access to the menu. After exiting the programming mode, the meter returns to its password protected condition.

### Disabling Password Protection

To disable the password protection, access the *Password* menu and enter the correct password twice, as shown below. The meter is now unprotected until a new password is entered.



If the correct six-digit password is entered, the meter displays the message *unLoc* (*unlocked*) and the protection is disabled until a new password is programmed.

If the password entered is incorrect, the meter displays the message *Locd* (*Locked*) for about two seconds, and then it returns to Run Mode. To try again, press Enter while the *Locked* message is displayed.

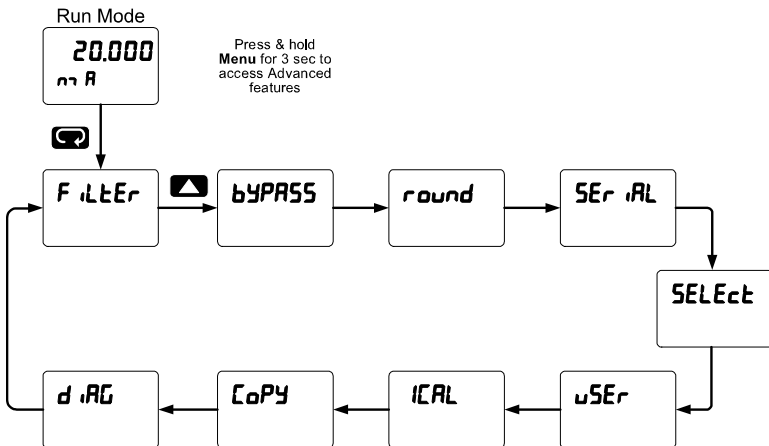
#### Did you forget the password?

The password may be disabled by entering a master password once. If you are authorized to make changes, enter the master password 508655 to unlock the meter.

## Advanced Features Menu

To simplify the setup process, functions not needed for most applications are located in the *Advanced Features* menu.

Press and hold the Menu button for three seconds to access the advanced features of the meter.



### Advanced Features Menu & Display Messages

The following table shows the functions and messages of the *Advanced Features* menu in the order they appear in the menu.

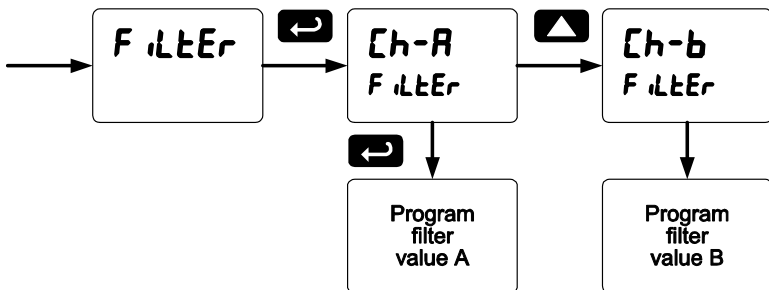
Display	Parameter	Action/Setting
<i>F iLLEr</i>	<i>Filter</i>	Set noise filter value
<i>[h-A</i>	<i>Channel A</i>	Set filter value for channel A
<i>[h-b</i>	<i>Channel B</i>	Set filter value for channel B
<i>bYPASS</i>	<i>Bypass</i>	Set filter bypass value
<i>[h-A</i>	<i>Channel A</i>	Set filter bypass value for channel A
<i>[h-b</i>	<i>Channel B</i>	Set filter bypass value for channel B
<i>round</i>	<i>Round</i>	Set the rounding value for display variables
<i>SER iRL</i>	<i>Serial</i>	Set serial communication parameters
<i>SLAVE id</i>	<i>Slave ID</i>	Set slave ID or meter address
<i>bAud</i>	<i>Baud rate</i>	Select baud rate
<i>tr dLY</i>	<i>Transmit delay</i>	Set transmit delay for serial communication
<i>PAR itY</i>	<i>Parity</i>	Select parity Even, Odd, or None with 1 or 2 stop bits
<i>t-byt</i>	<i>Time byte</i>	Set byte-to-byte timeout
<i>SELEct</i>	<i>Select</i>	Enter the Select menu (function, cutoff, out)
<i>FuncTn</i>	<i>Signal input conditioning</i>	Select linear, square root, programmable exponent, or round horizontal tank function
<i>[h-A</i>	<i>Channel A</i>	Select menu for channel A
<i>[h-b</i>	<i>Channel B</i>	Select menu for channel B
<i>L inERr</i>	<i>Linear</i>	Set meter for linear function and select number of linearization points
<i>no Pts</i>	<i>Number of points</i>	Set the number of linearization points (default: 2)
<i>SQRrE</i>	<i>Square root</i>	Set meter for square root extraction
<i>PrO E</i>	<i>Programmable exponent</i>	Set meter for programmable exponent and enter exponent value
<i>rht</i>	<i>Round horizontal tank</i>	Set meter for round horizontal tank volume calculation

Display	Parameter	Action/Setting
ד ררהו	<i>Diameter</i>	Enter the tank's diameter in inches
לנהטח	<i>Length</i>	Enter the tank's length in inches
חארה	<i>Math</i>	Enter the setup menu for channel C math functions
סחט	<i>Sum</i>	Channel C = (A+B+P)*F
ד IF	<i>Difference</i>	Channel C = (A-B+P)*F
ד IFAbS	<i>Absolute difference</i>	Channel C = ((Absolute value of (A-B))+P)*F
אנג	<i>Average</i>	Channel C = (((A+B)/2)+P)*F
חלטרה	<i>Multiplication</i>	Channel C = ((A*B)+P)*F
ד נו	<i>Divide</i>	Channel C = ((A/B)+P)*F
ח -Ab	<i>Max of A or B</i>	C = ((High value of channel A or B)+P)*F
ל -Ab	<i>Min of A or B</i>	C = ((Low value of channel A or B)+P)*F
דרא	<i>Draw</i>	Channel C = ((A/B)-1)*F
נגאנג	<i>Weighted average</i>	Channel C = ((B-A)*F)+A
ח א	<i>Ratio</i>	Channel C = (A/B)*F
לחנה	<i>Concentration</i>	Channel C = (A/(A+B))*F
לחנה	<i>Constant</i>	Constant used in channel C math
AddEr	<i>Adder</i>	Addition constant used in channel C math calculations
FActor	<i>Factor</i>	Multiplication constant used in channel C math calculations
לחנהFF	<i>Cutoff</i>	Set low-flow cutoff
אנהPr	<i>Analog output programming</i>	Program analog output parameters
Source	<i>Source</i>	Select source for the 4-20 mA output
ח -אנה	<i>Overrange</i>	Program mA output for display overrange
ח -אנה	<i>Underrange</i>	Program mA output for display underrange
חאח	<i>Maximum</i>	Program maximum mA output allowed
ח ח	<i>Minimum</i>	Program minimum mA output allowed

Display	Parameter	Action/Setting
ⓈRL Ⓛ	<i>Calibrate</i>	Calibrate 4-20 mA output (internal reference source used for scaling the output)
4 ⓈR	<i>4 mA output</i>	Enter mA output value read by milliamp meter with at least 0.001 mA resolution
20 ⓈR	<i>20 mA output</i>	Enter mA output value read by milliamp meter with at least 0.001 mA resolution
USEr	<i>User I/O</i>	Assign function keys and digital I/O
F 1	<i>F1 function key</i>	Assign F1 function key
F 2	<i>F2 function key</i>	Assign F2 function key
F 3	<i>F3 function key</i>	Assign F3 function key
F 4	<i>F4 function key</i>	Assign F4 function key (digital input)
d 1 i	<i>Digital input 1</i>	Assign digital input 1 – 8, if expansion modules are connected
d 0 i	<i>Digital output 1</i>	Assign digital output 1 – 8, if expansion modules are connected
iⓈRL	<i>Internal calibration</i>	Enter internal calibration (used for recalibrating the meter with a calibrated signal source)
Ⓢh-R	<i>Channel A</i>	Perform calibration on channel A
Ⓢh-b	<i>Channel B</i>	Perform calibration on channel B
Ⓢ ⓈRL	<i>Current calibration</i>	Calibrate 4-20 mA current input (internal reference source used for scaling the input)
Ⓢ LⓁ	<i>Current low</i>	Calibrate low current input (e.g. 4 mA)
Ⓢ H i	<i>Current high</i>	Calibrate high current input (e.g. 20 mA)
U ⓈRL	<i>Voltage calibration</i>	Calibrate voltage input
U LⓁ	<i>Voltage low</i>	Calibrate low voltage input (e.g. 0 V)
U H i	<i>Voltage high</i>	Calibrate high voltage input (e.g. 10 V)
ⓈoPY	<i>Copy</i>	Enter copy function
SEnd	<i>Send</i>	Send meter settings to another meter
donE	<i>Done</i>	Copy function completed
d ⓈR	<i>Diagnostics</i>	Display parameter settings

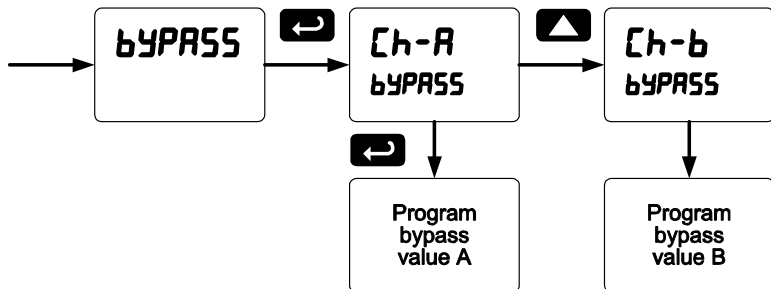
### Noise Filter (F ILtEr)

The noise filter is available for unusually noisy signals that cause an unstable process variable display. The noise filter averages the input signal over a certain period. The filter level determines the length of time over which the signal is averaged. The filter level can be set between 2 and 199. The higher the filter level, the longer the averaging time and so the longer it takes the display to settle to its final value. Setting the filter level to zero disables the filter function.



### Noise Filter Bypass (bYPASS)

The noise filter bypass changes the behavior of the meter so that small variations in the signal are filtered out but large abrupt changes in the input signal are displayed immediately. The bypass value determines the minimum amount of signal change to be displayed immediately. All signal changes smaller than the bypass value are filtered or averaged by the meter. The noise filter bypass may be set between 0.1 and 99.9% of full scale.



## Modbus RTU Serial Communications (SEr AL)

The meter is equipped with serial communications capability as a standard feature using Modbus RTU Serial Communication Protocol.

To communicate with a computer or other data terminal equipment, an RS-232 or RS-485 adapter option is required; see *Ordering Information* on page 7 for details.

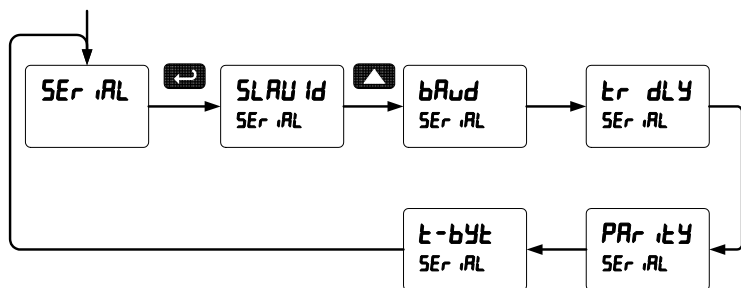


### Warning!

Do not connect any equipment other than Yokogawa Corporation of America's expansion modules, cables, or meters to the RJ45 M-LINK connector. Otherwise damage will occur to the equipment and the meter.

*Note: More detailed instructions are provided with each optional serial communications adapter.*

*Note: Refer to the **PROPLUS** Modbus Register Tables located at [www.yokogawa-usa.com](http://www.yokogawa-usa.com) for details.*



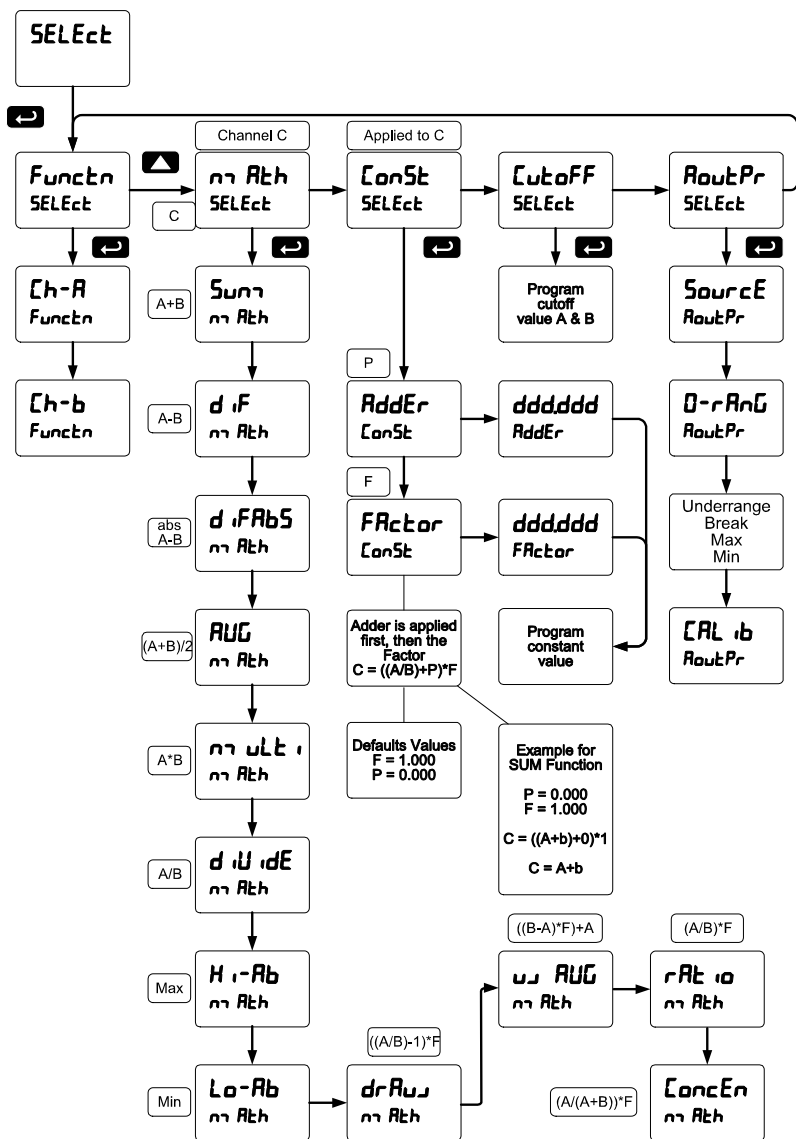
When using more than one meter in a multi-drop mode, each meter must be provided with its own unique address. The meter address (Slave ID) may be programmed between 1 and 247. The transmit delay may be set between 0 and 199 ms. The parity can be set to even, odd, or none with 1 or 2 stop bits.

The meter can also be connected to similar meter with a special YPPA1200 cable, allowing the user to copy all the settings from one meter to another, using the *Copy* function.

### Select Menu (SELEct)

The *Select* menu is used to select the signal input conditioning function applied to the inputs (linear, square root, programmable exponent, or round horizontal tank), math function for A & B, constants, low-flow cutoff, and analog output programming. The multi-point linearization is part of the linear function selection.

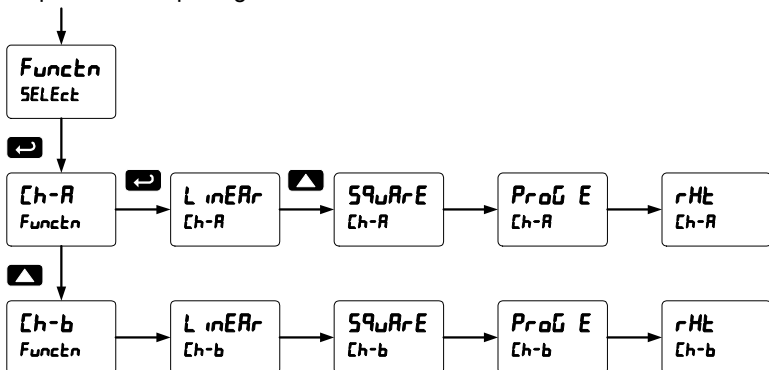




## Signal Input Conditioning (*Function*)

The *Function* menu is used to select the input-to-output transfer function applied to the input signal: linear, square root, programmable exponent, or round horizontal tank volume calculation. The multi-point linearization is part of the linear function selection.

Meters are set up at the factory for linear function with 2-point linearization. The linear function provides a display that is linear with respect to the input signal.



### Square Root Linearization (**SQURrE**)

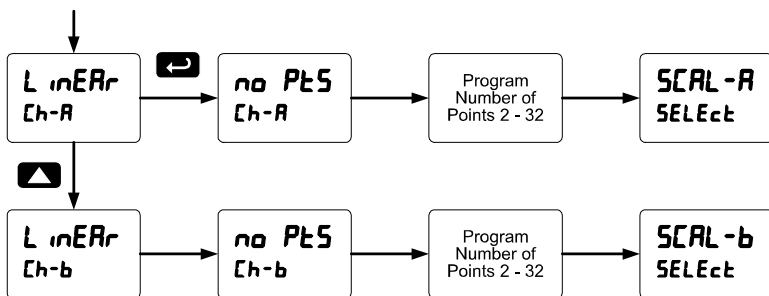
The square root function is used to calculate flow measured with a differential pressure transmitter. The flow rate is proportional to the square root of the differential pressure. Scale the meter so that the low input signal (e.g. 4 mA) is equal to zero flow and the high input signal (e.g. 20 mA) is equal to the maximum flow.

### Programmable Exponent Linearization (**ProG E**)

The programmable exponent function is used to calculate open-channel flow measured with a level transmitter in weirs and flumes. The flow rate is proportional to the head height. Scale the meter so that the low input signal (e.g. 4 mA) is equal to zero flow and the high input signal (e.g. 20 mA) is equal to the maximum flow. This method works well for all weirs and flumes that have a simple exponent in the flow calculation formula. For weirs and flumes with complex exponents it is necessary to use a strapping table and the 32-point linearization of the meter.

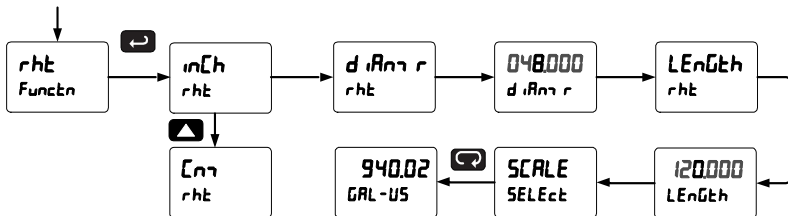
### Multi-Point Linearization (L inERr)

Meters are set up at the factory for linear function with 2-point linearization. Up to 32 linearization points can be selected for each channel under the linear function. The multi-point linearization can linearize the display for non-linear signals such as those from level transmitters used to measure volume in odd-shaped tanks or to convert level to flow using weirs and flumes with complex exponent.



### Round Horizontal Tank Linearization (rHt)

This function is used to calculate volume in a round horizontal tank with flat ends. The volume is calculated based on the diameter and length of the tank. The tank's dimensions can be entered in inches or centimeters; the meter automatically calculates the volume in gallons or liters. After entering the dimensions, complete the scaling process with the display values calculated by the meter. The meter can be re-scaled to display the volume in any engineering unit without the need to re-enter the dimensions again.



*Note: After Scale is displayed continue pressing the Enter button until the meter completes the scaling of the input and display values.*

### Changing the Volume from Gallons to Liters

In the above graphic, entering the 48" for the diameter and 120" for the length of the round horizontal tank, the meter automatically calculates that the volume of the tank is 940.02 gallons.

1. Convert gallons to liters  
1 US gallon = 3.7854 L  
940.02 gal = 3558.4 L
2. Go to the *Setup* menu and change the decimal point to 1 decimal.
3. Go to the *Program – Scale* menu and press Enter until *d 15 2* is shown on the main display.
4. Press Enter and change the display 2 value to 3558.4.
5. The meter is now displaying the volume in liters.

*Note: The display can be scaled to display the volume in any engineering units.*

### Low-Flow Cutoff (LutOFF)

The low-flow cutoff feature allows the meter to be programmed so that the often-unsteady output from a differential pressure transmitter, at low flow rates, always displays zero on the meter.

The cutoff value may be programmed from 0 to 999999. The meter will display zero below the cutoff value. Programming the cutoff value to zero disables the cutoff feature.

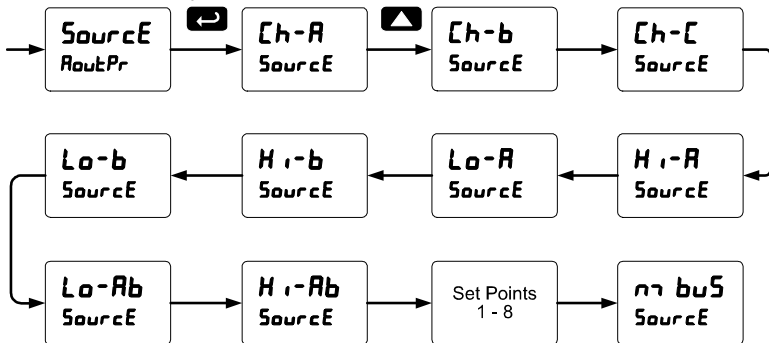
### Analog Output Programming (RoutPr)

The *Analog Output Programming* menu is used to program the behavior of the 4-20 mA output. The following parameters and functions are programmed in this menu:

1. Source: Source for generating the 4-20 mA output (e.g. channel A)
2. Overrange: Analog output value with display in overrange condition
3. Underrange: Analog output value with display in underrange condition
4. Break: Analog output value when loop break is detected
5. Max: Maximum analog output value allowed regardless of input
6. Min: Minimum analog output value allowed regardless of input
7. Calibrate: Calibrate the internal 4-20 mA source reference used to scale the 4-20 mA output

### Analog Output Source

The analog output source can be based on either of the input channels (Ch-A, Ch-B), the math channel (Ch-C), maximum stored value of either input channel (Hi-A, Hi-B), minimum stored value of either input channel (Lo-A, Lo-B), relay set points, or the Modbus input.

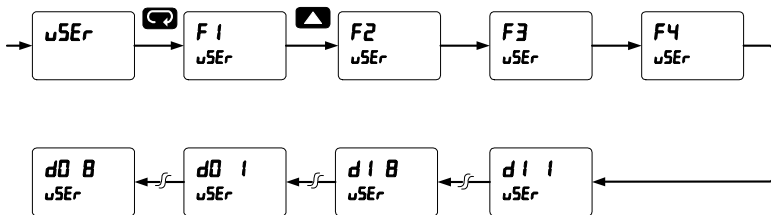


### Analog Output Calibration

To perform the analog output calibration it is recommended to use a milliamp meter with a resolution of at least 0.1  $\mu\text{A}$  to measure the output current. The values saved internally during this procedure are used for scaling the 4-20 mA output in the *Setup* menu.

## Programmable Function Keys User Menu (uSEr)

The *User* menu allows the user to assign the front panel function keys F1, F2, F3, F4 and up to eight digital inputs to access most of the menus or to activate functions immediately (e.g. Reset max & min). F4 is a digital input on the signal input connector. Up to eight digital outputs can be assigned to a number of actions and functions executed by the meter (e.g. Alarms, relay acknowledgement, etc.).



### Function Keys & Digital I/O Available Settings

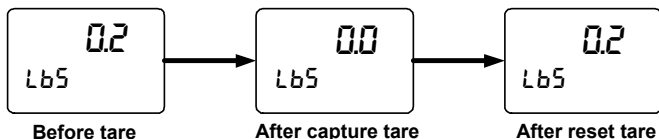
Display	Description	Display	Description
RcH	Acknowledge relays	L i t H C	Max on little display (Channel C)
rSt H i	Reset max (A, B, C)	L i t L C	Min on little display (Channel C)
rSt Lo	Reset min (A, B, C)	L i t H L C	Max/min little display (Channel C)
rSt HL	Reset max & min (A, B, C)	d i s A b L	Disable function key
rELAY	Relay menu	m n E n u	Menu button
SEt 1	Set point 1 - 8	r i g h t	Right arrow button
rLY d	Disable relay	u P	Up arrow button
rLY E	Enable relay	E n t E r	Enter button
o HoLd	Relay output hold	R L r n n i	Alarm 1 – 8 (Digital Output)
d HoLd	Display hold while active	F o n i	Force on relay 1

$d RbC$	Scrolls the values for A, B, & C every time it is activated. Stays on the last value for 10 seconds and then it returns to its assignment. The values are displayed on the big display and the corresponding channel and units on the small display.	$F on 2$	Force on relay 2
$b i H i$	Max on big display (Channel A)	$F on 3$	Force on relay 3
$b i L o$	Min on big display (Channel A)	$F on 4$	Force on relay 4
$b i H L$	Max/min big display (Channel A)	$t R r E A$	Set channel A display value to zero (A LED flashes – same rate as M)*
$L i H i$	Max on little display (Channel B)	$t R r E b$	Set channel B display value to zero (B LED flashes – same rate as M)*
$L i L o$	Min on little display (Channel B)	$r 5 t t r$	Reset tare for A & B (Channel LED off)
$L i H L$	Max/min little display (Channel B)		

\* If math functions are displayed, the math function indicator LED “C” will flash when either A or B channel is using a tare value (net value).

## Tare (LRrE A, LRrE b)

The tare function zero's out the display. In the case of scale weight, tare is used to eliminate container weight and provide net weight readings. There are two tare functions; Capture Tare for channel A and B, and Reset Tare. Display channel indicator letter flashes when a tare is used. It will flash until the tare is reset.



Gross (without tare) and net (with tare) values can be viewed simultaneously. See page 42.

## Internal Calibration (IRL)

The meter is factory calibrated prior to shipment to read in milliamps and volts depending on the input selection. The calibration equipment is certified to NIST standards.

The use of calibrated signal sources is necessary to perform the internal calibration of the meter.

Check calibration of the meter at least every 12 months. Each input must be recalibrated separately.

### Notes:

1. If meter is in operation and it is intended to accept only one input type (e.g. 4-20 mA), recalibration of other input is not necessary.
2. Allow the meter to warm up for at least 15 minutes before performing the internal calibration procedure.

The *Internal calibration* menu is part of the *Advanced Features* menu.

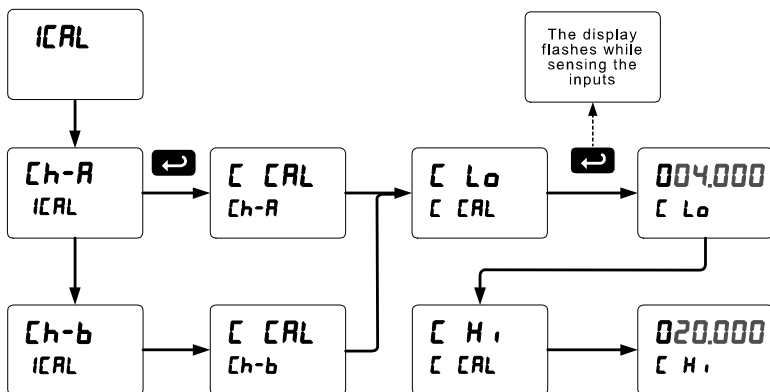
1. Press and hold the Menu button for three seconds to access the advanced features of the meter.
2. Press the Up arrow button to scroll to the *Internal calibration* menu (IRL) and press Enter.



3. Select channel A ( $\text{[Ch-A]}$ ) or channel B ( $\text{[Ch-b]}$ ) and press enter.
4. The meter displays either current calibration ( $\text{[CAL]}$ ) or voltage calibration ( $\text{[V CAL]}$ ), according to the input setup. Press Enter to start the calibration process.

**Example of Internal Calibration for current input:**

5. The meter displays *low* input current message ( $\text{[Lo]}$ ). Apply the low input signal and press Enter. The display flashes for a moment while the meter is accepting the low input signal.
6. After the display stops flashing, a number is displayed with the leftmost digit brighter than the rest. The bright digit is the active digit that can be changed by pressing the Up arrow button. Press the Right arrow button to move to the next digit.
7. Set the display value to correspond to the input signal being calibrated, typically 4.000 mA.
8. The display moves to the *high* input calibration ( $\text{[Hi]}$ ). Apply the high input signal and press Enter.
9. Set the display for the high input calibration, in the same way as it was set for the low input calibration, typically 20.000 mA.



The graphic above shows the calibration of the current input. The voltage input is calibrated in a similar way.

**Tips:**

- Low and high input signals can be any valid values within the range of the meter.
- Observe minimum input span requirements between input 1 and input 2.
- Low input should be less than high input signal.

**Error Message (Error)**

An error message indicates that the calibration or scaling process was not successful.

After the error message is displayed, the meter reverts to input 2 during calibration or scaling and to input 1 during internal calibration, allowing the appropriate input signal to be applied or programmed.

The error message might be caused by any of the following conditions:

1. Input signal is not connected to the proper terminals, or it is connected backwards.
2. Wrong signal selection in *Setup* menu.
3. Minimum input span requirements not maintained.

**Minimum Input Span**

The minimum input span is the minimum difference between input 1 and input 2 signals required to complete the calibration or scaling of the meter.

Input Range	Input 1 & Input 2 Span
4-20 Ma	0.15 mA
±10 VDC	0.10 VDC

## Meter Copy Function (Копия)

The *Copy* function is used to copy (or clone) all the settings from one meter to other meters requiring exactly the same setup and programming (*i.e.* type of input, scaling, decimal point, filter, bypass, etc.).



### Warning!

Only the YPPA1200 meter copy cable must be used for meter-to-meter interfacing. The YPPA1200 is a special eight-conductor flat cable with two wires swapped.

Using standard CAT5 or other cable will cause damage to both meters.

YPPA1200 Meter Copy Cable



Figure 20. Meter Copy Connection

### Copy Function Requirements

To successfully copy settings from one meter to another, both meters must have:

1. Same software version
2. Same baud rate setting

See *Determining Software Version*, page 87 for instructions.

### Meter Copy or Cloning Instructions



### Caution!

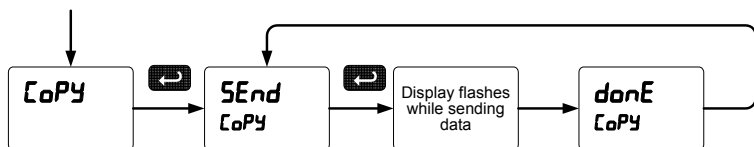
Do not connect the two meters to the same signal source while cloning. Internal calibration may be affected.

1. Connect two meters using a YPPA1200 meter copy cable.

**Warning!**

Using standard CAT5 or other cable will cause damage to both meters. Use YPPA1200 meter copy cable only.

2. Do not connect the two meters to the same signal source.
3. Power up both meters. Leave Clone meter in Run Mode.
4. Enter the *Advanced Features* menu of the Master meter; see *Advanced Features Menu* on page 66.
5. Scroll to the *Copy* function using the Up arrow button then press Enter.
6. The meter displays the message *SEnd*. Press Enter, the display flashes while sending data. The message *donE* is displayed when copying is completed.



7. The Clone meter displays the message *CPY rc* while being programmed then the message *donE* when copying is completed. The meter initializes and returns to Run Mode using the same settings as the Master.
8. If meter to be cloned does not respond to the data being sent, refer to **Copy Function Requirements** above.

## METER OPERATION





The meter is capable of accepting current (0-20 mA, 4-20 mA) and voltage signals (0-5 V, 1-5 V, 0-10 V,  $\pm 10$  V) and displaying these signals in engineering units from -99999 to 999999 (e.g. a 4-20 mA signal could be displayed as -50.000 to 50.000).

The dual-line display can be customized by the user to operate in such a way as to satisfy a specific application. Typically the main display is used for the process variable; while the second display is used engineering units, custom legend, or set point indication.

The analog input can be scaled to display the process in two different scales; for example the main display could indicate level in feet and the second display could indicate the volume in gallons.

Additionally the meter can be set up to display the analog input on the main display and the Modbus input on the second display. The relays and analog output can be programmed to operate from the Modbus PV input.

### Front Panel Buttons Operation

Button Symbol	Description
	Press to enter or exit Programming Mode, view settings, or exit max/min readings
	Press to reset max/min readings or other parameter/function assigned through the <i>User</i> menu
	Press to display max/min readings or other parameter/function assigned through the <i>User</i> menu
	Press to acknowledge relays or other parameters/function assigned through the <i>User</i> menu

### Function Keys Operation

During operation, the programmable function keys operate according to the way they have been programmed in the *Advanced Features – User* menu.

The table above shows the factory default settings for F1, F2, and F3.

## F4 Operation

A digital input, F4, is standard on the meter. This digital input is programmed identically to function keys F1, F2, and F3. The input is triggered with a contact closure to COM, or with an active low signal. During operation, F4 operates according to the way it has been programmed in the *Advanced Features – User* menu.

## Maximum/Minimum Readings

The max & min readings (peak & valley) reached by the process can be displayed either continuously or momentarily:

1. Display briefly by assigning to the F1-F3 function keys or to the digital inputs in the *User* menu.
2. Display continuously by assigning either display to max/min through the *Display* menu.

Any of the F1-F3 function keys (buttons) and the digital inputs can be programmed to reset the max & min readings. The meters are set at the factory to display the max reading by pressing the Up arrow/F2 button and to use the Right arrow/F1 button to access the *Reset* menu.

### To display max and min channel A reading using function key with factory defaults:

1. Press Up arrow/F2 button to display minimum reading of channel A since the last reset/power-up. The display will then display the maximum reading of channel A since the last reset/power-up.
2. To reset max/min press Right arrow/F1 button to access the *Reset* menu. The max & min displays are reset to actual values.
3. Press Menu to exit max/min display reading.

## TROUBLESHOOTING

The rugged design and the user-friendly interface of the meter should make it unusual for the installer or operator to refer to this section of the manual. However, due to the many features and functions of the meter, it's possible that the setup of the meter does not agree with what an operator expects to see.

If the meter is not working as expected, refer to the *Diagnostics* menu and recommendations below.

### **Diagnostics Menu (d iRL)**

The *Diagnostics* menu is located in the *Advanced Features* menu, to access *Diagnostics* menu see *Advanced Features Menu*, page 66.

It provides an easy way to view the programmed parameter settings for troubleshooting purposes. Press the Enter button to view the settings and the Menu button to exit at any time.

For a description of the diagnostic messages, see *Advanced Features Menu & Display Messages*, page 67.

### **Determining Software Version**

To determine the software version of a meter:

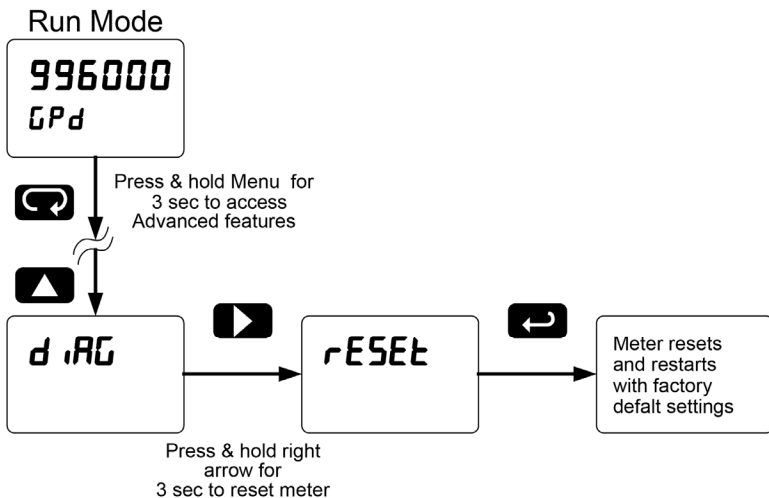
1. Go to the *Diagnostics* menu (d iRL) and press Enter button.
2. Press Up arrow button and scroll to Information menu ( iRFd).
3. Press Enter to access the software number (5Ft) and version (UER) information. Write down the information as it is displayed. Continue pressing Enter until all the information is displayed.
4. The meter returns to Run Mode after displaying all the settings.

## Reset Meter to Factory Defaults

When the parameters have been changed in a way that is difficult to determine what's happening, it might be better to start the setup process from the factory defaults.

### Instructions to load factory defaults:

1. Enter the *Advanced Features* menu. See *Advanced Features Menu*, page 66.
2. Press Up arrow to go to *Diagnostics* menu
3. Press and hold Right arrow for five seconds, press Enter when display flashes *rESEt*.  
Note: If Enter is not pressed within three seconds, the display returns to the *Diagnostics* menu.
4. The meter goes through an initialization sequence (similar as on power-up), and loads the factory default settings.





## Factory Defaults & User Settings

The following table shows the factory setting for most of the programmable parameters on the meter. Next to the factory setting, the user may record the new setting for the particular application.

Model: \_\_\_\_\_ S/N: \_\_\_\_\_ Date: \_\_\_\_\_

Parameter	Display	Default Setting	User Setting
Input type	<i>InPut</i>		
Input type, channel A	<i>Ch-A</i>	4-20 mA	
Input type, channel B	<i>Ch-b</i>	4-20 mA	
Unit	<i>unit</i>		
Unit, channel A	<i>Ch-A</i>	mA-A	
Unit, channel B	<i>Ch-b</i>	mA-B	
Unit, channel C	<i>Ch-C</i>	mA-C	
Number of points	<i>no Pt5</i>		
Number of points, ch A)	<i>Ch-A</i>	2	
Number of points, ch B)	<i>Ch-b</i>	2	
Scaling, (channel A)	<i>ScAL A</i>		
Input 1, channel A	<i>InP 1</i>	4.000 mA	
Display 1, channel A	<i>d 15 1</i>	4.000	
Input 2, channel A	<i>InP 2</i>	20.000 mA	
Display 2, channel A	<i>d 15 2</i>	20.000	
Scaling (channel B)	<i>ScAL b</i>		
Input 1, channel B	<i>InP 1</i>	4.000 mA	
Display 1, channel B	<i>d 15 1</i>	4.000	
Input 2, channel B	<i>InP 2</i>	20.000 mA	
Display 2, channel B	<i>d 15 2</i>	20.000	
Math, channel C	<i>Sum</i>	Sum	
Adder (constant P)	<i>AddEr</i>	0.000	
Factor (constant F)	<i>FActEr</i>	1	
Filter	<i>FiLTER</i>		

Parameter	Display	Default Setting	User Setting
Filter, channel A	$\text{[h-A]}$	70	
Filter, channel B	$\text{[h-b]}$	70	
Bypass	$\text{bYPASS}$	0.2	
Round	$\text{rOund}$	1	
Cutoff	$\text{[u]tOFF}$		
Cutoff value, channel A	$\text{[h-A]}$	0.000 (disabled)	
Cutoff value, channel B	$\text{[h-b]}$	0.000 (disabled)	
Display assignment	$\text{dSP[LA]RY}$		
Big display (Main)	$\text{d [h-A]}$	Channel A	
Little display (Small)	$\text{d [h-b]}$	Channel B	
Display intensity	$\text{d-INTY}$	8	
Relay 1 assignment	$\text{[h-A]}$	Channel A	
Relay 1 action	$\text{Rct 1}$	Automatic	
Relay 1 set point	$\text{SEt 1}$	1.000	
Relay 1 reset point	$\text{rSEt 1}$	0.500	
Relay 2 assignment	$\text{[h-A]}$	Channel A	
Relay 2 action	$\text{Rct 2}$	Automatic	
Relay 2 set point	$\text{SEt 2}$	2.000	
Relay 2 reset point	$\text{rSEt 2}$	1.500	
Relay 3 assignment	$\text{[h-A]}$	Channel A	
Relay 3 action	$\text{Rct 3}$	Automatic	
Relay 3 set point	$\text{SEt 3}$	3.000	
Relay 3 reset point	$\text{rSEt 3}$	2.500	
Relay 4 assignment	$\text{[h-A]}$	Channel A	
Relay 4 action	$\text{Rct 4}$	Automatic	
Relay 4 set point	$\text{SEt 4}$	4.000	
Relay 4 reset point	$\text{rSEt 4}$	3.500	
Fail-safe relay 1	$\text{FLS 1}$	Off	

Parameter	Display	Default Setting	User Setting
Fail-safe relay 2	FLS 2	Off	
Fail-safe relay 3	FLS 3	Off	
Fail-safe relay 4	FLS 4	Off	
On delay relay 1	On 1	0.0 sec	
Off delay relay 1	OFF 1	0.0 sec	
On delay relay 2	On 2	0.0 sec	
Off delay relay 2	OFF 2	0.0 sec	
On delay relay 3	On 3	0.0 sec	
Off delay relay 3	OFF 3	0.0 sec	
On delay relay 4	On 4	0.0 sec	
Off delay relay 4	OFF 4	0.0 sec	
Loop break relay 1	Ignore	Ignore	
Loop break relay 2	Ignore	Ignore	
Loop break relay 3	Ignore	Ignore	
Loop break relay 4	Ignore	Ignore	
Display 1 analog out	d15 1	4.000	
Output 1 value	Out 1	4.000 mA	
Display 2 analog out	d15 2	20.000	
Output 2 value	Out 2	20.000 mA	
Source analog output	Source	Channel A	
Overrange output	OverRng	21.000 mA	
Underrange output	UnderRng	3.000 mA	
Loop break output	brErr	1.000 mA	
Maximum output	max RH	23.000 mA	
Minimum output	min in	0.000 mA	
Slave ID (Address)	SLAVE id	247	
Baud rate	baud	9600	
Transmit delay	tr dLY	10 ms	

Parameter	Display	Default Setting	User Setting
Parity	<i>PRr</i> <i>⌘</i>	Even	
Byte-to-byte timeout	<i>⌘-b</i> <i>⌘</i>	010 (0.1 sec)	
F1 function key	<i>F 1</i>	Reset max & min	
F2 function key	<i>F 2</i>	Big Max & Min	
F3 function key	<i>F 3</i>	Acknowledge relays	
F4 function key (digital input)	<i>F 4</i>	Disable	
Digital input 1	<i>d i 1</i>	Menu	
Digital input 2	<i>d i 2</i>	Right arrow	
Digital input 3	<i>d i 3</i>	Up arrow	
Digital input 4	<i>d i 4</i>	Enter	
Digital output 1	<i>d o 1</i>	Alarm 1	
Digital output 2	<i>d o 2</i>	Alarm 2	
Digital output 3	<i>d o 3</i>	Alarm 3	
Digital output 4	<i>d o 4</i>	Alarm 4	
Password 1	<i>PASS 1</i>	000000 (unlocked)	
Password 2	<i>PASS 2</i>	000000 (unlocked)	
Password 3	<i>PASS 3</i>	000000 (unlocked)	

## Troubleshooting Tips

Symptom	Check/Action
No display at all	Check power at power connector
Not able to change setup or programming, <b>LoCd</b> is displayed	Meter is password-protected, enter correct six-digit password to unlock
Meter displays error message during calibration ( <b>Error</b> )	Check: <ol style="list-style-type: none"> <li>Signal connections</li> <li>Input selected in <i>Setup</i> menu</li> <li>Minimum input span requirements</li> </ol>
Meter displays <ol style="list-style-type: none"> <li>999999</li> <li>-999999</li> </ol>	Check: <ol style="list-style-type: none"> <li>Input selected in <i>Setup</i> menu</li> <li>Corresponding signal at Signal connector</li> </ol>
Display is unstable	Check: <ol style="list-style-type: none"> <li>Input signal stability and value</li> <li>Display scaling vs. input signal</li> <li>Filter and bypass values (increase)</li> </ol>
Display response is too slow	Check filter and bypass values
Display reading is not accurate	Check: <ol style="list-style-type: none"> <li>Signal input conditioner selected: Linear, square root, etc.</li> <li>Scaling or calibration</li> </ol>
Display does not respond to input changes, reading a fixed number	Check: <ol style="list-style-type: none"> <li>Display assignment, it might be displaying max, min, or set point.</li> </ol>
Display alternates between <ol style="list-style-type: none"> <li><b>H</b> and a number</li> <li><b>Lo</b> and a number</li> </ol>	Press Menu to exit max/min display readings.
Relay operation is reversed	Check: <ol style="list-style-type: none"> <li>Fail-safe in <i>Setup</i> menu</li> <li>Wiring of relay contacts</li> </ol>
Relay and status LED do not respond to signal	Check: <ol style="list-style-type: none"> <li>Relay action in <i>Setup</i> menu</li> <li>Set and reset points</li> </ol>
Flashing relay status LEDs	Relays in manual control mode or relay interlock switches opened.
Meter not communicating with application programs	Check: <ol style="list-style-type: none"> <li>Serial adapter and cable</li> <li>Serial settings</li> <li>Meter address and baud rate</li> </ol>
If the display locks up or the meter does not respond at all	Cycle the power to reboot the microprocessor.
Other symptoms not described above	Call Technical Support for assistance.

## Alphabetical List of Display Functions & Messages

Display	Parameter	Action/Setting Description
-99999	Flashing	Underrange condition
999999	display	Overrange condition
20 mA A	20 mA output	Enter mA output value read by milliamp meter with at least 0.001 mA resolution
4 mA A	4 mA output	Enter mA output value read by milliamp meter with at least 0.001 mA resolution
A Gross	Display A gross	Display input channel A gross (no tare)
A Net-G	Display A net and gross	Alternate display of channel A net (tare) and gross (no tare)
ACK	Acknowledge	Acknowledge relays
Action 1	Action 1	Set relay 1 action
Adder	Adder	The channel C math function adder constant P
Alarm 1	Alarm 1	Assign digital output to Alarm 1-8
Alternate	Alternate	Set relay for pump alternation control
Auto-manual	Auto-manual	Set relay for automatic & manual reset
Analog output	Analog output	Enter the <i>Analog output</i> scaling menu
Analog output programming	Analog output programming	Enter analog output programming
Assign	Assign	Enter the relay channel assignment menu
Auto	Automatic	Press Enter to set automatic operation
B Gross	Display B gross	Display input channel B gross (no tare)
B Net-G	Display B net and gross	Alternate display of channel B net (tare) and gross (no tare)
Baud	Baud rate	Select baud rate
Big display	Big display	Press Enter to assign the main display parameter (default: Ch-A)
Max on big display	Max on big display	Assign digital input to display max on the main display (channel A)
Max/min big display	Max/min big display	Assign digital input to toggle max/min on the main display (channel A)
Min on big display	Min on big display	Assign digital input to display min on the main display (channel A)
Loop break	Loop break	Set relay condition if loop break detected
Bypass	Bypass	Set filter bypass value
Current calibration	Current calibration	Calibrate 4-20 mA current input (internal reference source used for scaling the input)
Current high	Current high	Calibrate high current input (e.g. 20 mA)
Current low	Current low	Calibrate low current input (e.g. 4 mA)
Calibrate A	Calibrate A	Enter the <i>Calibration</i> menu for channel A
Calibrate B	Calibrate B	Enter the <i>Calibration</i> menu for channel B
Calibrate	Calibrate	Calibrate 4-20 mA output (internal reference source used for scaling the output)

Display	Parameter	Action/Setting Description
Ch-A	Channel A	Channel A selection
Ch-b	Channel B	Channel B selection
Ch-C	Channel C	Channel C selection
cm	Centimeter	Select cm as the tank unit of measurement
Const	Constant	Enter the math function constant menu
Control	Control	Enter <i>Control</i> menu to turn relays on/off, set analog output manually, or return meter to automatic operation
Copy	Copy	Enter copy function
Cutoff	Cutoff	Set low-flow cutoff (ch-A, ch-B)
d Ab	Display A & B	Alternate display of channel A & B
d AbC	Display A, B, & C	Alternate display of channel A, B, & C
d AC	Display A & C	Alternate display of channel A & C
d A-u	Display A and units/tags	Alternate display of channel A and the unit/tag
d bC	Display B & C	Alternate display of channel B & C
d b-u	Display B and units/tags	Alternate display of channel B and the unit/tag
d Ch-A	Display Ch-A	Assign display to channel A
d Ch-b	Display Ch-B	Assign display to channel B
d Ch-C	Display Ch-C	Assign display to channel C (math)
d C-u	Display C and units/tags	Alternate display of channel C and the unit/tag
d Hi-A	Display Hi A	Display high value of channel A
d Hi-b	Display Hi B	Display high value of channel B
d Hi-C	Display Hi C	Display high value of channel C
d HL-A	Display Hi/Low A	Alternate between high/low value of channel A
d HL-b	Display Hi/Low B	Alternate between high/low value of channel B
d HL-C	Display Hi/Low C	Alternate between high/low value of channel C
d Hold	Display Hold	Set digital inputs and function keys for display hold
d Lo-A	Display Lo A	Display low value of channel A
d Lo-b	Display Lo B	Display low value of channel B
d Lo-C	Display Lo C	Display low value of channel C
d off	Display off	Display off (blank)
d unit	Display unit	Display unit of channel A
Dec Pt	Decimal point	Set decimal point
DELAY	Delay	Enter relay <i>Time Delay</i> menu
d i 1	Digital input 1	Assign digital input 1-8, if expansion modules are connected
d RC	Diagnostics	Display parameter settings

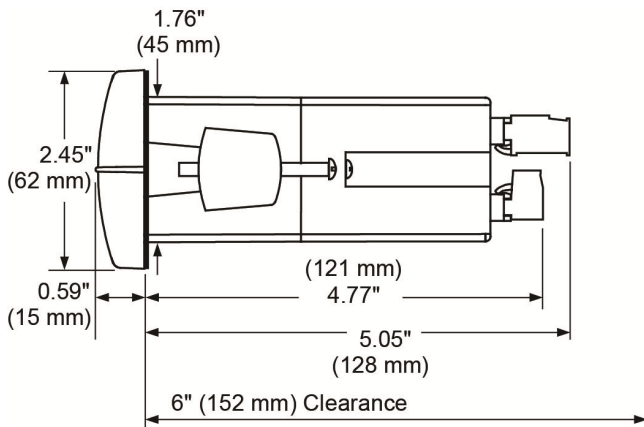
Display	Parameter	Action/Setting Description
diameter	<i>Diameter</i>	Enter the tank's diameter in inches or cm
display intensity	<i>Display intensity</i>	Set display intensity level from 1 to 8
display 1	<i>Display 1</i>	Program display 1 value
display 2	<i>Display 2</i>	Program display 2 value (up to 32 points)
disable	<i>Disable</i>	Disable function key
delay 1	<i>Delay 1</i>	Enter relay 1 time delay setup (1-8)
digital output 1	<i>Digital output 1</i>	Assign digital output 1 – 8, if expansion modules are connected
done	<i>Done</i>	Copy function completed
display set 1	<i>Display set 1</i>	Select to display set point 1 (1-8)
display	<i>Display</i>	Enter the <i>Display</i> menu
enter	<i>Enter button</i>	Assign digital input to Enter button/F3
error	<i>Error</i>	Error, calibration not successful, check signal or programmed value
force on 1	<i>Force On 1</i>	Force relay 1 on using and digital input
F1	<i>F1 function key</i>	Assign F1 function key
F2	<i>F2 function key</i>	Assign F2 function key
F3	<i>F3 function key</i>	Assign F3 function key
F4	<i>F4 function key</i>	Assign F4 function key (digital input)
factor	<i>Factor</i>	The channel C math function multiplication factor constant F
fail-safe	<i>Fail-safe</i>	Enter <i>Fail-safe</i> menu
filter	<i>Filter</i>	Set noise filter value
fail-safe 1	<i>Fail-safe 1</i>	Set relay 1 fail-safe operation (1-8)
force	<i>Force</i>	Force analog output value for loop break
function	<i>Signal input conditioner</i>	Select linear, square root, programmable exponent, or round horizontal tank function
internal calibration	<i>Internal calibration</i>	Enter internal calibration (used for recalibrating the meter with a calibrated signal source)
ignore	<i>Ignore</i>	Ignore loop break condition
inch	<i>Inch</i>	Select inch as the tank unit of measurement
info	<i>Information</i>	Display software and S/N information
input 1	<i>Input 1</i>	Calibrate input 1 signal or program input 1 value
input 2	<i>Input 2</i>	Calibrate input 2 signal or program input 2 value (up to 32 points)
input	<i>Input</i>	Enter <i>Input</i> selection menu
latching	<i>Latching</i>	Set relay for latching operation
led test	<i>LED test</i>	Test all LEDs
length	<i>Length</i>	Enter the tank's length in inches or cm
linear	<i>Linear</i>	Set meter for linear function and select number of linearization points
max on little	<i>Max on little</i>	Assign digital input to display max of



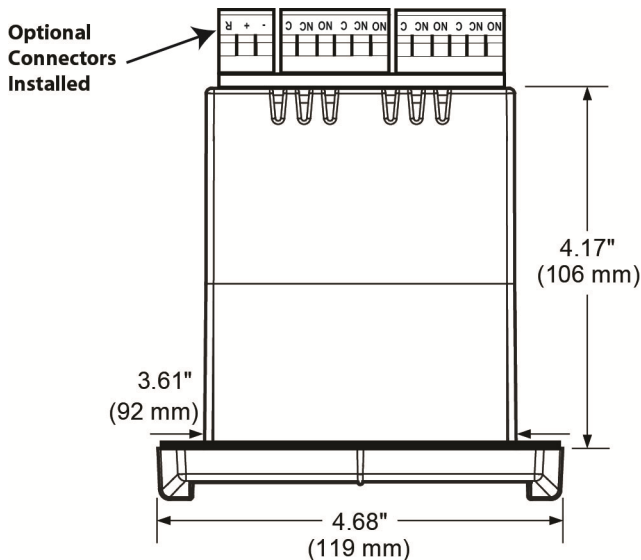
Display	Parameter	Action/Setting Description
	<i>display</i>	channel C on the small display
Ⓒ Ⓔ H Ⓘ	Max on little display	Assign digital input to display max of channel A on the small display
Ⓒ Ⓔ HL	Max/min little display	Assign digital input to toggle max/min of channel A on the small display
Ⓒ Ⓔ HLL	Max/Min little display	Assign digital input to toggle max/min of channel C on the small display
Ⓒ Ⓔ LL	Min on little display	Assign digital input to display min of channel C on the small display
Ⓒ Ⓔ Lo	Min on little display	Assign digital input to display min of channel A on the small display
Ⓒ ⒺLE	<i>Little display</i>	Press Enter to assign the small display parameter (default: Ch-B)
Locd	<i>Locked</i>	Enter password to unlock meter
ⒸⒺ-ⒸⒸr	<i>Latching-cleared</i>	Set relay for latching operation with manual reset only after alarm condition has cleared
ⒸⒸ R	4-20 mA	Set meter for 4-20 mA input
ⒸⒸ Rn	<i>Manual</i>	Press Enter to manually control relays or analog output operation
ⒸⒸ RCh	<i>Math</i>	Select channel C math function
ⒸⒸ RH	<i>Maximum</i>	Program maximum mA output allowed
ⒸⒸ Ⓒu5	Modbus	Select to display Modbus input or to assign Modbus input as the analog output source
ⒸⒸ Ⓒn	Menu button	Assign digital input to Menu button
ⒸⒸ Ⓒn	<i>Minimum</i>	Program minimum mA output allowed
ⒸⒸ PLS	<i>Num of points</i>	Set meter for 2 to 32-point linearization
ⒸⒸ HoLd	Relays output hold	Assign digital input or function keys to hold all relay states
OFF	<i>Off</i>	Disable relay and front panel status LED, turn relays off, program off time delay
OFF 1	<i>Off 1</i>	Set relay 1 Off time delay (1-8)
On	<i>On</i>	Enable fail-safe operation, turn relays on, program on time delay
Ⓒ-r RnG	<i>Overrange</i>	Program mA output for display overrange
Ⓒu1	<i>Output 1</i>	Program output 1 value (e.g. 4.000 mA)
Ⓒu2	<i>Output 2</i>	Program output 2 value (e.g. 20.000 mA)
PASS	<i>Password</i>	Enter the <i>Password</i> menu
PASS 1	<i>Password 1</i>	Set or enter Password 1 (Allows use of the F1-F3 function keys)
PASS 2	<i>Password 2</i>	Set or enter Password 2 (Allows use of the F1-F3 function keys and changing the set/reset points)
PASS 3	<i>Password 3</i>	Set or enter Password 3 (Restricts all programming & F1-F3 keys)
Prog	<i>Program</i>	Enter the <i>Program</i> menu

Display	Parameter	Action/Setting Description
PrOg E	Programmable exponent	Set meter for programmable exponent and enter exponent value
rELAY	Relay	Enter the <i>Relay</i> menu
rESEt	Reset	Press Enter to access the <i>Reset</i> menu
rHt	Round horizontal tank	Set meter for round horizontal tank volume calculation
r iHt	Right arrow	Assign digital input to Right arrow button/F1
rLY 1	Relay 1	Relay 1 setup (1-8)
rLY d	Disable relay	Assign digital input and function keys to disable all relays
rLY E	Enable relay	Assign digital input to enable all relays
rOund	Round	Enter the round menu
rSEt 1	Reset 1	Program reset point 1 (1-8)
rSEt H i	Reset high	Press Enter to reset max display
rSEt HL	Reset high & low	Press Enter to reset max & min displays
rSEt Lo	Reset low	Press Enter to reset min display
rSEt tR	Reset tare	Reset tare
SAnG PL	Sampling	Set relay for sampling operation
SCAL A	Scale A	Enter the <i>Scale</i> menu for channel A
SCAL b	Scale B	Enter the <i>Scale</i> menu for channel B
SELEct	Select	Enter Select menu (function, round, math, constant, cutoff, output programming)
SEnd	Send	Send meter settings to another meter
SEr iAL	Serial	Set serial communication parameters
SEt 1	Set 1	Program set point 1 (1-8)
SEtUP	Setup	Enter <i>Setup</i> menu
SLAVe id	Slave ID	Set Slave ID or meter address
SourcE	Source	Select source for the 4-20 mA output
SQuArE	Square root	Set meter for square root extraction
tArE A	Tare A	Activate tare on channel A
tArE B	Tare B	Activate tare on channel B
tR dLY	Transmit delay	Set transmit delay for serial communication
un it	unit	Enter in channel A, B, and C input units/tags
unLoc	Unlocked	Program password to lock meter
uP	Up arrow	Assign digital input to Up arrow button/F2
u-rAnG	Underrange	Program mA output for display underrange
uSEr	User I/O	Assign function keys and digital I/O
U CAL	Voltage calibration	Calibrate voltage input
U H i	Voltage high	Calibrate high voltage input (e.g. 10 V)
U Lo	Voltage low	Calibrate low voltage input (e.g. 0 V)
uOLt	Volt	Set meter for volt input

## MOUNTING DIMENSIONS



**Figure 21. Meter Dimensions - Side View**



**Figure 22. Meter Dimensions - Top View**





**Figure 23. 1/8 DIN Panel Cutout Template**





## How to Contact Yokogawa Corporation of America

- For Sales and Technical Support please  
Call: (800) 888-6400 or (770) 254-0400  
Fax: (770) 251-2088  
Email: [meters-instr@us.yokogawa.com](mailto:meters-instr@us.yokogawa.com)
- For the latest version of this manual please visit  
[www.yokogawa-usa.com](http://www.yokogawa-usa.com)