

YPP6000 Analog Input Process Meter

Instruction Manual



PROPLUS



- 0-20 mA, 4-20 mA, 0-5 V, 1-5 V, and ± 10 V Inputs
- NEMA 4X, IP65 Front
- Universal 85-265 VAC, or 12/24 VDC Input Power Models
- Large Dual-Line 6-Digit Display, 0.60" & 0.46"
- Dual-Scale for Level Applications – Single Input
- Sunlight Readable Display Models
- Isolated 24 VDC @ 200 mA Transmitter Power Supply
- Signal Input Conditioning for Flow & Round Horizontal Tanks
- Programmable Display & Function Keys
- 32-Point, Square Root, or Exponential Linearization
- Multi-Pump Alternation Control
- 2 or 4 Relays + Isolated 4-20 mA Output Options
- External 4-Relay & Digital I/O Expansion Modules
- USB, RS-232, RS-485 Serial Communication Options
- Modbus[®] RTU Communication Protocol Standard
- Tare Function
- Free **PROPLUS** Software for Operation, Monitoring, and Programming

YOKOGAWA ◆

2 Dart Road • Newnan, Georgia 30265
770-253-7000 • 800-888-6400

Fax: 770-251-2088 • www.yokogawa-usa.com

Disclaimer

The information contained in this document is subject to change without notice. Yokogawa Corporation of America makes no representations or warranties with respect to the contents hereof and specifically disclaims any implied warranties of merchantability or fitness for a particular purpose.



CAUTION: Read complete instructions prior to installation and operation of the meter.



WARNING: Risk of electric shock or personal injury.



Warning!

This product is not recommended for life support applications or applications where malfunctioning could result in personal injury or property loss. Anyone using this product for such applications does so at his/her own risk. Yokogawa Corporation of America shall not be held liable for damages resulting from such improper use.

Limited Warranty

Yokogawa Corporation of America warrants this product against defects in material or workmanship for the specified period under "Specifications" from the date of shipment from the factory. Yokogawa's liability under this limited warranty shall not exceed the purchase value, repair, or replacement of the defective unit.

Registered Trademarks

All other trademarks mentioned in this document are the property of their respective owners.

© 2011 Yokogawa Corporation of America. All rights reserved.

www.yokogawa-usa.com

Table of Contents

INTRODUCTION	6
ORDERING INFORMATION	7
SPECIFICATIONS	8
General	8
Process Input	9
Relays	10
Isolated 4-20 mA Transmitter Output	11
Modbus [®] RTU Serial Communications	11
YPPA1044 Digital Input & Output Expansion Module	12
COMPLIANCE INFORMATION	13
Safety	13
Electromagnetic Compatibility	13
SAFETY INFORMATION	14
INSTALLATION	15
Unpacking	15
Panel Mounting Instructions	15
Configuration for 12 or 24 VDC Power Option	16
Transmitter Supply Voltage Selection (P+, P-)	17
Connections	17
Connectors Labeling	18
Power Connections	18
Signal Connections	19
Modbus RTU Serial Communications	20
Relay Connections	20
Switching Inductive Loads	21
4-20 mA Output Connections	22
Analog Output Transmitter Power Supply	22
External Relays & Digital I/O Connections	23
Interlock Relay Feature	24
SETUP AND PROGRAMMING	25
Front Panel Buttons and Status LED Indicators	26
Display Functions & Messages	27
Main Menu	30
Setting Numeric Values	31
Reset Menu (rESEt)	31
Control Menu (ContRL)	31

Setting Up the Meter (SEtUP) -----	32
Setting the Input Signal (INPUt)-----	33
Setting the Decimal Point (dEc Pt)-----	33
Programming the Meter (PrOG)-----	34
Program Menu for Single Scale Process-----	34
Program Menu for Dual-Scale Level Applications-----	34
Multi-Point Calibration & Scaling-----	35
PROPLUS Software-----	35
Scaling the Meter (ScALe)-----	36
Dual-Scale for Level Application-----	37
Calibrating the Meter with External Source (cAL)-----	39
Setting the Display Parameter & Intensity (dSPLRy)-----	40
Display Setup Menu-----	41
Character Set for Engineering Units Display (d UNit)-----	42
Setting the Relay Operation (rELAY) -----	43
Setting the Relay Action-----	45
Programming Set and Reset Points-----	46
Setting Fail-Safe Operation-----	46
Programming Time Delay-----	46
Relay Action for Loss of 4-20 mA Input (Loop Break)-----	46
Relay and Alarm Operation Diagrams -----	47
High Alarm Operation (Set > Reset)-----	47
Low Alarm Operation (Set < Reset)-----	48
High Alarm with Fail-Safe Operation (Set > Reset)-----	49
Low Alarm with Fail-Safe Operation (Set < Reset)-----	50
Pump Alternation Control Operation-----	51
Relay Sampling Operation-----	52
Signal Loss or Loop Break Relay Operation-----	53
Time Delay Operation-----	54
Relay Operation Details -----	55
Overview-----	55
Relays Auto Initialization-----	55
Fail-Safe Operation-----	55
Front Panel LEDs-----	56
Latching and Non-Latching Relay Operation-----	56
Non-Latching Relay (RUnl)-----	57
Non-Latching Relay (R-nr Rn)-----	57
Latching Relay (LRtch)-----	57
Latching Relay (Lt-clr)-----	58
Acknowledging Relays-----	58
Pump Alternation Control Applications (RLtErn)-----	59
Setting Up the Interlock Relay (Force On) Feature-----	62

Model YPP6000 Analog Input Process Meter	Instruction Manual
Scaling the 4-20 mA Analog Output (Rout)	63
Setting Up the Password (PASS)	64
Protecting or Locking the Meter	64
Making Changes to a Password Protected Meter	65
Disabling Password Protection	65
Advanced Features Menu	66
Advanced Features Menu & Display Messages	67
Noise Filter (FILTER)	69
Noise Filter Bypass (bYPASS)	69
Modbus RTU Serial Communications (SERIAL)	70
Select Menu (SELECT)	71
Signal Input Conditioning (FUNCTION)	71
Low-Flow Cutoff (LOWOFF)	74
Analog Output Programming (ROUTPR)	74
Programmable Function Keys User Menu (USER)	75
Tare (TARE)	76
Internal Source Calibration (IRL)	76
Meter Copy Function (COPY)	79
METER OPERATION	81
Front Panel Buttons Operation	81
Function Keys Operation	81
Maximum/Minimum Readings	82
TROUBLESHOOTING	83
Diagnostics Menu (dIAG)	83
Determining Software Version	83
Reset Meter to Factory Defaults	84
Factory Defaults & User Settings	85
Troubleshooting Tips	88
Alphabetical List of Display Functions & Messages	89
DIMENSIONS	95

Table of Figures

Figure 1. 1/8 DIN Panel Cutout Dimensions	15
Figure 2. Panel Mounting Details	16
Figure 3. Jumper Configuration for 12/24 VDC Power	16
Figure 4. Transmitter Supply Voltage Selection	17
Figure 5. Connector Labeling for Fully Loaded YPP6000	18
Figure 6. Power Connections	18
Figure 7. Transmitters Powered by Internal Supply	19
Figure 8. Transmitter Powered by Ext. Supply or Self-Powered	19
Figure 9. Voltage Input Connections	20
Figure 10. Relay Connections	20
Figure 11. AC and DC Loads Protection.....	21
Figure 12. Low Voltage DC Loads Protection	21
Figure 13. 4-20 mA Output Connections	22
Figure 14. Expansion Modules & DIN Rail Mounting Kit.....	23
Figure 15. External Relays Module Connections.....	23
Figure 16. Digital I/O Module Connections.....	24
Figure 17. Interlock Connections	24
Figure 18. Acknowledge Relays w/Function Key or Digital Input ..	58
Figure 19. Meter Copy Connection	79
Figure 20. Meter Dimensions - Side View.....	95
Figure 21. Meter Dimensions - Top View.....	95
Figure 22. 1/8 DIN Panel Cutout Template.....	97

INTRODUCTION

The **PROPLUS** YPP6000 is a multipurpose, easy to use digital process meter ideal for level, flow rate, temperature, or pressure transmitter applications. It accepts current and voltage signals (e.g. 4-20 mA, 0-10 V). Three of the front panel buttons can be custom-programmed for a specific operation. The analog input can be scaled to display the process in two different scales; for example the main display could indicate level in feet and the second display could indicate the volume in gallons.

The basic model includes an isolated 24 VDC transmitter power supply that can be used to power the input transmitter or other devices. An additional isolated 24 VDC power supply is included with the 4-20 mA output option.

A fully loaded YPP6000 meter has the following: four SPDT relays, 4-20 mA output, and two 24 VDC power supplies. The YPP6000 capabilities may be enhanced by adding the following external expansion modules: four SPST relays –creating an eight-relay process meter–, two digital I/O modules with four inputs and four outputs each, and USB, RS-232 or RS-485 communication adapters.

The eight relays can be used for alarm indication or process control applications, such as pump alternation control. The 4-20 mA isolated output, Modbus RTU serial communications, and digital I/O options make the YPP6000 an excellent addition to any system.

ORDERING INFORMATION**Standard Models**

85-265 VAC Model	12/24 VDC Model	Options Installed
YPP6000-6R0	YPP6000-7R0	No options
YPP6000-6R2	YPP6000-7R2	2 relays
YPP6000-6R3	YPP6000-7R3	4-20 mA output
YPP6000-6R4	YPP6000-7R4	4 relays
YPP6000-6R5	YPP6000-7R5	2 relays & 4-20 mA output
YPP6000-6R7	YPP6000-7R7	4 relays & 4-20 mA output

SunBright Display Models

85-265 VAC Model	12/24 VDC Model	Options Installed
YPP6000-6H0	YPP6000-7H0	No options
YPP6000-6H2	YPP6000-7H2	2 relays
YPP6000-6H3	YPP6000-7H3	4-20 mA output
YPP6000-6H4	YPP6000-7H4	4 relays
YPP6000-6H5	YPP6000-7H5	2 relays & 4-20 mA output
YPP6000-6H7	YPP6000-7H7	4 relays & 4-20 mA output

Accessories

Model	Description
YPPA1002	DIN rail mounting kit for two expansion modules
YPPA1004	4 SPST (Form A) relays
YPPA1044	4 digital inputs & 4 digital outputs (2 may be connected)
YPPA1200	Meter copy cable
YPPA1232	RS-232 serial adapter
YPPA1485	RS-485 serial adapter
YPPA8008	USB serial adapter
YPPA7485-I	RS-232 to RS-422/485 isolated converter
YPPA7485-N	RS-232 to RS-422/485 non-isolated converter
YPPA8232-N	USB to RS-232 non-isolated converter
YPPA8485-I	USB to RS-422/485 isolated converter
YPPA8485-N	USB to RS-422/485 non-isolated converter
YPPX6901	Suppressor (snubber): 0.01 μ F/470 Ω , 250 VAC

Enclosures

Model	Description
YPPA2811	1 Meter Plastic NEMA 4X Enclosure
YPPA2812	2 Meter Plastic NEMA 4X Enclosure

SPECIFICATIONS

Except where noted all specifications apply to operation at +25°C.

General

DISPLAY	Main display: 0.60" (15 mm) high, red LEDs Second display: 0.46" (12 mm) high, red LEDs 6 digits each (-99999 to 999999), with lead zero blanking
DISPLAY INTENSITY	Eight user selectable intensity levels
DISPLAY UPDATE RATE	5/second (200 ms)
OVERRANGE	Display flashes 999999
UNDERRANGE	Display flashes -99999
DISPLAY ASSIGNMENT	The main (Big) and small (Little) displays may be assigned to PV1, PV2, PCT, max/min, alternate max & min, set points, units (small display only), and Modbus input.
PROGRAMMING METHODS	Four front panel buttons, digital inputs, PC and PROPLUS software, Modbus registers, or cloning using Copy function.
NOISE FILTER	Programmable from 2 to 199 (0 will disable filter)
FILTER BYPASS	Programmable from 0.1 to 99.9% of calibrated span
RECALIBRATION	All ranges are calibrated at the factory. Recalibration is recommended at least every 12 months.
MAX/MIN DISPLAY	Max/min readings reached by the process are stored until reset by the user or until power to the meter is turned off.
PASSWORD	Three programmable passwords restrict modification of programmed settings. Pass 1: Allows use of function keys and digital inputs Pass 2: Allows use of function keys, digital inputs and editing set/reset points Pass 3: Restricts all programming, function keys, and digital inputs.
NON-VOLATILE MEMORY	All programmed settings are stored in non-volatile memory for a minimum of ten years if power is lost.
POWER OPTIONS	85-265 VAC 50/60 Hz, 90-265 VDC, 20 W max or jumper selectable 12/24 VDC \pm 10%, 15 W max
FUSE	Required external fuse: UL Recognized, 5 A max, slow blow; up to 6 meters may share one 5 A fuse
ISOLATED TRANSMITTER POWER SUPPLY	Terminals P+ & P-: 24 VDC \pm 5% @ 200 mA max (standard), (12/24 VDC powered models rated @ 100 mA max). 5 or 10 VDC @ 50 mA max, selectable with internal jumper J4.

Model YPP6000 Analog Input Process Meter Instruction Manual

NORMAL MODE REJECTION	Greater than 60 dB at 50/60 Hz
ISOLATION	4 kV input/output-to-power line 500 V input-to-output or output-to-P+ supply
OVERVOLTAGE CATEGORY	Installation Overvoltage Category II: Local level with smaller transient overvoltages than Installation Overvoltage Category III.
ENVIRONMENTAL	Operating temperature range: -40 to 65°C Storage temperature range: -40 to 85°C Relative humidity: 0 to 90% non-condensing
CONNECTIONS	Removable screw terminal blocks accept 12 to 22 AWG wire, RJ45 for external relays, digital I/O, and serial communication adapters.
ENCLOSURE	1/8 DIN, high impact plastic, UL 94V-0, color: black
MOUNTING	1/8 DIN panel cutout required: 3.622" x 1.772" (92 mm x 45 mm) Two panel mounting bracket assemblies are provided.
TIGHTENING TORQUE	Screw terminal connectors: 5 lb-in (0.56 Nm)
OVERALL DIMENSIONS	4.68" x 2.45" x 5.64" (119 mm x 62 mm x 143 mm) (W x H x D)
WEIGHT	9.5 oz (269 g)
WARRANTY	3 years parts & labor

Process Input

INPUTS	Field selectable: 0-20, 4-20 mA, ± 10 V (0-5, 1-5, 0-10 V), Modbus PV (Slave)
ACCURACY	$\pm 0.03\%$ of calibrated span ± 1 count, square root & programmable exponent accuracy range: 10-100% of calibrated span
TEMPERATURE DRIFT	0.005% of calibrated span/ $^{\circ}$ C max from 0 to 65°C ambient, 0.01% of calibrated span/ $^{\circ}$ C max from -40 to 0°C ambient
SIGNAL INPUT CONDITIONING	Linear, square root, programmable exponent, or round horizontal tank volume calculation
MULTI-POINT LINEARIZATION	2 to 32 points for PV or PV1 2 to 8 points for PV2 (Dual-scale Level feature)
PROGRAMMABLE EXPONENT	1.0001 to 2.9999
LOW-FLOW CUTOFF	0-999999 (0 disables cutoff function)

DECIMAL POINT	Up to five decimal places or none: <i>d.aaaaa, d.aaaa, d.aaa, d.aa, da, or daaaaa</i>						
CALIBRATION RANGE	<table border="0"> <tr> <td>Input Range</td> <td>Minimum Span Input 1 & Input 2</td> </tr> <tr> <td>4-20 mA</td> <td>0.15 mA</td> </tr> <tr> <td>±10 V</td> <td>0.10 V</td> </tr> </table> <p>An error message will appear if the input 1 and input 2 signals are too close together.</p>	Input Range	Minimum Span Input 1 & Input 2	4-20 mA	0.15 mA	±10 V	0.10 V
Input Range	Minimum Span Input 1 & Input 2						
4-20 mA	0.15 mA						
±10 V	0.10 V						
INPUT IMPEDANCE	<p>Voltage ranges: greater than 1 MΩ</p> <p>Current ranges: 50 - 100 Ω (depending on resettable fuse impedance)</p>						
INPUT OVERLOAD	<p>Current input protected by resettable fuse, 30 VDC max.</p> <p>Fuse resets automatically after fault is removed.</p>						

Relays

RATING	2 or 4 SPDT (Form C) internal and/or 4 SPST (Form A) external; rated 3 A @ 30 VDC and 125/250 VAC resistive load; 1/14 HP (\approx 50 W) @ 125/250 VAC for inductive loads
NOISE SUPPRESSION	Noise suppression is recommended for each relay contact switching inductive loads; see page 21 for details.
DEADBAND	0-100% of span, user programmable
HIGH OR LOW ALARM	User may program any alarm for high or low trip point. Unused alarm LEDs and relays may be disabled (turn off).
RELAY OPERATION	<p>Automatic (non-latching)</p> <p>Latching (requires manual acknowledge)</p> <p>Sampling (based on time)</p> <p>Pump alternation control (2 to 8 relays)</p> <p>Off (disable unused relays and enable Interlock feature)</p> <p>Manual on/off control mode</p>
RELAY RESET	<p>User selectable via front panel buttons or digital inputs</p> <ol style="list-style-type: none"> Automatic reset only (non-latching), when the input passes the reset point. Automatic + manual reset at any time (non-latching) Manual reset only, at any time (latching) Manual reset only after alarm condition has cleared (L) <p><i>Note: Front panel button or digital input may be assigned to acknowledge relays programmed for manual reset.</i></p>
TIME DELAY	0 to 999.9 seconds, on & off relay time delays Programmable and independent for each relay
FAIL-SAFE OPERATION	<p>Programmable and independent for each relay.</p> <p><i>Note: Relay coil is energized in non-alarm condition.</i></p> <p><i>In case of power failure, relay will go to alarm state.</i></p>

AUTO INITIALIZATION	When power is applied to the meter, relays will reflect the state of the input to the meter.
----------------------------	----------------------------------------------------------------------------------------------

Isolated 4-20 mA Transmitter Output

OUTPUT SOURCE	Process variable (PV), max, min, set points 1-8, Modbus input, or manual control mode		
SCALING RANGE	1.000 to 23.000 mA for any display range		
CALIBRATION	Factory calibrated: 4.000 to 20.000 = 4-20 mA output		
ANALOG OUT PROGRAMMING	23.000 mA maximum for all parameters: Overrange, underrange, max, min, and break		
ACCURACY	$\pm 0.1\%$ of span ± 0.004 mA		
TEMPERATURE DRIFT	0.4 $\mu\text{A}/^\circ\text{C}$ max from 0 to 65°C ambient, 0.8 $\mu\text{A}/^\circ\text{C}$ max from -40 to 0°C ambient <i>Note: Analog output drift is separate from input drift.</i>		
ISOLATED TRANSMITTER POWER SUPPLY	Terminals I+ & R: 24 VDC $\pm 5\%$ @ 40 mA maximum; may be used to power the 4-20 mA output or other devices. Refer to Figure 5 on page 18 and Figure 13 on page 22.		
EXTERNAL LOOP POWER SUPPLY	35 VDC maximum		
OUTPUT LOOP RESISTANCE	Power supply	Minimum	Maximum
	24 VDC	10 Ω	700 Ω
	35 VDC (external)	100 Ω	1200 Ω

Modbus® RTU Serial Communications

SLAVE ID	1 – 247 (Meter address)
BAUD RATE	300 – 19,200 bps
TRANSMIT TIME DELAY	Programmable between 0 and 199 ms
DATA	8 bit (1 start bit, 1 or 2 stop bits)
PARITY	Even, Odd, or None with 1 or 2 stop bits
BYTE-TO-BYTE TIMEOUT	0.01 – 2.54 second
TURN AROUND DELAY	Less than 2 ms (fixed)

*Note: Refer to the **PROPLUS** Modbus Register Tables located at www.yokogawa-usa.com for details.*

YPPA1044 Digital Input & Output Expansion Module

CHANNELS	4 digital inputs & 4 digital outputs per module
SYSTEM	Up to 2 modules for a total of 8 inputs & 8 outputs
DIGITAL INPUT LOGIC HIGH	3 to 5 VDC
DIGITAL INPUT LOGIC LOW	0 to 1.25 VDC
DIGITAL OUTPUT LOGIC HIGH	3.1 to 3.3 VDC
DIGITAL OUTPUT LOGIC LOW	0 to 0.4 VDC
SOURCE CURRENT	10 mA maximum output current
SINK CURRENT	1.5 mA minimum input current
+5 V TERMINAL	To be used as pull-up for digital inputs only. Connect normally open contacts across +5 V & DI 1-4.

COMPLIANCE INFORMATION**Safety**

UL & c-UL LISTED	USA & Canada UL 508 Industrial Control Equipment
UL FILE NUMBER	E348677
FRONT PANEL	UL Type 4X, NEMA 4X, IP65; panel gasket provided
LOW VOLTAGE DIRECTIVE	EN 61010-1:2001 Safety requirements for measurement, control, and laboratory use

Electromagnetic Compatibility

EMISSIONS	EN 55022:2006/A1:2007 Class A ITE emissions requirements
Radiated Emissions	Class A
AC Mains Conducted Emissions	Class A
IMMUNITY	EN 61326-1:2006 Measurement, control, and laboratory equipment EN 61000-6-2:2005 EMC heavy industrial generic immunity standard
RFI - Amplitude Modulated	80 -1000 MHz 10 V/m 80% AM (1 kHz) 1.4 - 2.0 GHz 3 V/m 80% AM (1 kHz) 2.0 - 2.7 GHz 1 V/m 80% AM (1 kHz)
Electrical Fast Transients	±2kV AC mains, ±1kV other
Electrostatic Discharge	±4kV contact, ±8kV air
RFI - Conducted	10V, 0.15-80 MHz, 1kHz 80% AM
AC Surge	±2kV Common, ±1kV Differential
Surge	1KV (CM)
Power-Frequency Magnetic Field	3 A/m 70%V for 0.5 period
Voltage Dips	40%V for 5 & 50 periods 70%V for 25 periods
Voltage Interruptions	<5%V for 250 periods

Note:

Testing was conducted on YPP6000 meters installed through the covers of grounded metal enclosures with cable shields grounded at the point of entry representing installations designed to optimize EMC performance.

Declaration of Conformity available at www.yokogawa-usa.com

SAFETY INFORMATION



CAUTION: Read complete instructions prior to installation and operation of the meter.



WARNING: Risk of electric shock or personal injury.



WARNING!

Hazardous voltages exist within enclosure. Installation and service should be performed only by trained service personnel.

INSTALLATION

There is no need to remove the meter from its case to complete the installation, wiring, and setup of the meter for most applications.

Instructions are provided for setting up a 12/24 VDC powered meter to operate from 12 VDC and for changing the transmitter power supply to output 5 or 10 VDC instead of 24 VDC, see page 16.

Unpacking

Remove the meter from box. Inspect the packaging and contents for damage. Report damages, if any, to the carrier.

If any part is missing or the meter malfunctions, please contact your supplier or the factory for assistance.

Panel Mounting Instructions

- Prepare a standard 1/8 DIN panel cutout – 3.622" x 1.772" (92 mm x 45 mm). Refer to Figure 1 below, for more details.
- Clearance: allow at least 6.0" (152 mm) behind the panel for wiring.
- Panel thickness: 0.04" - 0.25" (1.0 mm - 6.4 mm).
Recommended minimum panel thickness to maintain Type 4X rating: 0.06" (1.5 mm) steel panel, 0.16" (4.1 mm) plastic panel.
- Remove the two mounting brackets provided with the meter (back-off the two screws so that there is 1/4" (6.4 mm) or less through the bracket. Slide the bracket toward the front of the case and remove).
- Insert meter into the panel cutout.
- Install mounting brackets and tighten the screws against the panel. To achieve a proper seal, tighten the mounting bracket screws evenly until meter is snug to the panel along its short side. **DO NOT OVER TIGHTEN**, as the rear of the panel may be damaged.

Note: See Figure 22 on page 97 for 1/8 DIN Panel Cutout Template

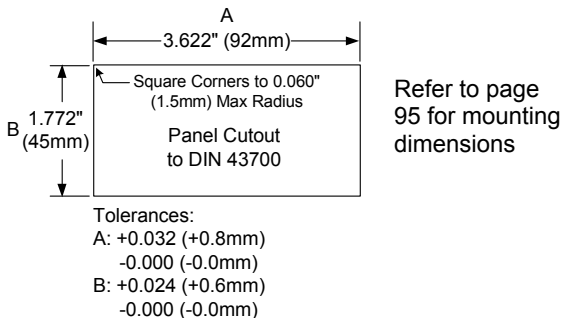

Figure 1. 1/8 DIN Panel Cutout Dimensions

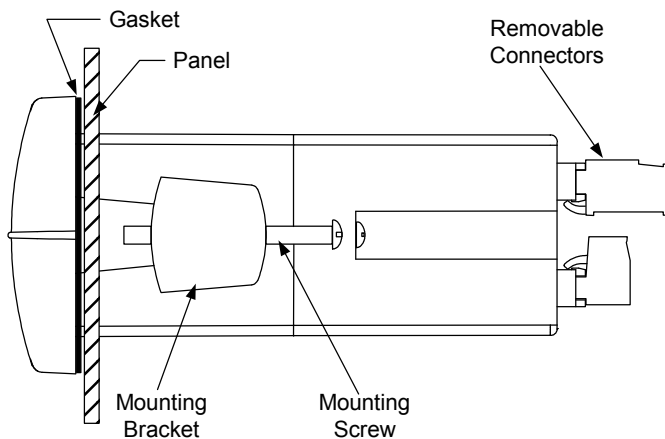

Figure 2. Panel Mounting Details

Configuration for 12 or 24 VDC Power Option



Do not exceed voltage rating of the selected configuration.

Meters equipped with the 12/24 VDC power option are shipped from the factory ready to operate from 24 VDC.

To configure the meter for 12 VDC power:

1. Remove all the connectors.
2. Unscrew the back cover.
3. Slide the back cover about 1 inch.
4. Configure the J9 jumper, located behind the power connector, for 12 V as shown below.

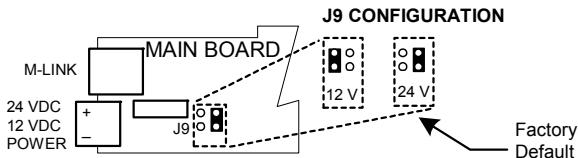

Figure 3. Jumper Configuration for 12/24 VDC Power

Transmitter Supply Voltage Selection (P+, P-)

All meters, including models equipped with the 12/24 VDC power option, are shipped from the factory configured to provide 24 VDC power for the transmitter or sensor.

If the transmitter requires 5 or 10 VDC excitation, the internal jumper J4 must be configured accordingly.

To access the voltage selection jumper:

1. Remove all the wiring connectors.
2. Unscrew the back cover.
3. Slide out the back cover by about 1 inch.
4. Configure the J4 jumper, located behind the input signal connector, for the desired excitation voltage as shown.

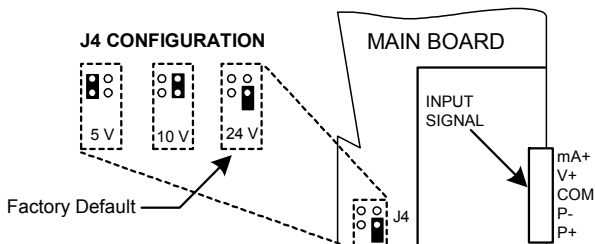

Figure 4. Transmitter Supply Voltage Selection

Connections

All connections are made to removable screw terminal connectors located at the rear of the meter.



Use copper wire with 60°C or 60/75°C insulation for all line voltage connections. Observe all safety regulations. Electrical wiring should be performed in accordance with all applicable national, state, and local codes to prevent damage to the meter and ensure personnel safety.

Connectors Labeling

The connectors' label, affixed to the meter, shows the location of all connectors available with requested configuration.



Warning!

Do not connect any equipment other than Yokogawa's expansion modules, cables, or meters to the RJ45 M-LINK connector. Otherwise damage will occur to the equipment and the meter.

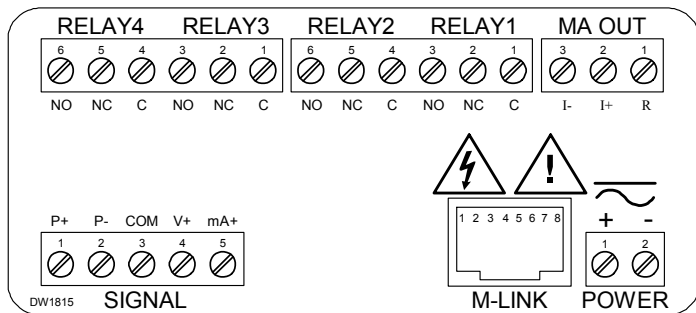
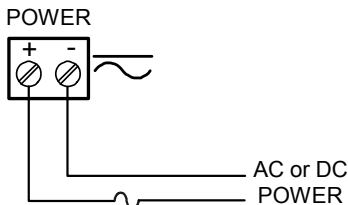

Figure 5. Connector Labeling for Fully Loaded YPP6000

Power Connections

Power connections are made to a two-terminal connector labeled POWER on Figure 5. The meter will operate regardless of DC polarity connection. The + and - symbols are only a suggested wiring convention.



Required External Fuse:
5 A max, 250 V Slow Blow

Figure 6. Power Connections

Signal Connections

Signal connections are made to a five-terminal connector labeled SIGNAL on Figure 5. The COM (common) terminal is the return for the 4-20 mA and the ± 10 V input signals.

Current and Voltage Connections

The following figures show examples of current and voltage connections. There are no switches or jumpers to set up for current and voltage inputs. Setup and programming is performed through the front panel buttons.

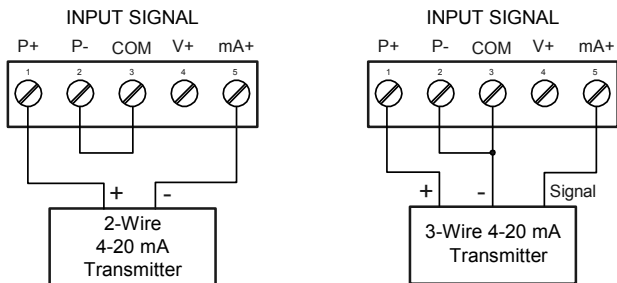

Figure 7. Transmitters Powered by Internal Supply

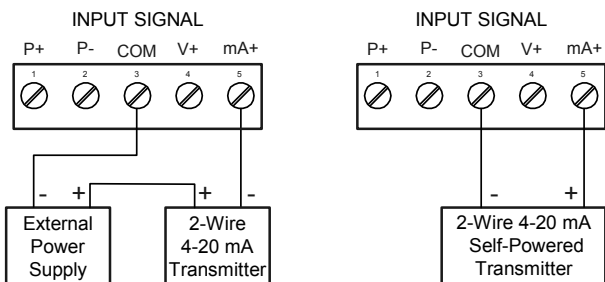

Figure 8. Transmitter Powered by Ext. Supply or Self-Powered

The current input is protected against current overload by a resettable fuse. The display may or may not show a fault condition depending on the nature of the overload.

The fuse limits the current to a safe level when it detects a fault condition, and automatically resets itself when the fault condition is removed.

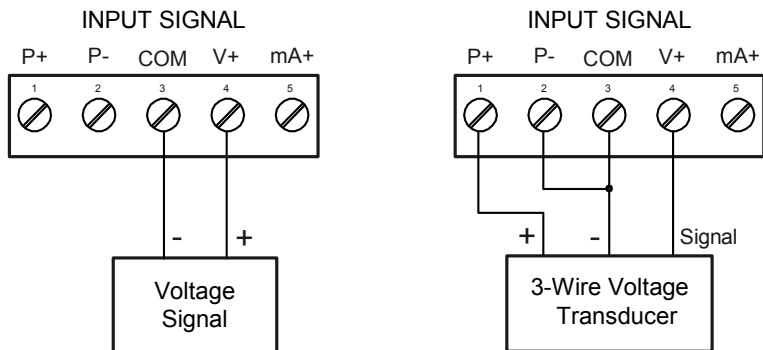

Figure 9. Voltage Input Connections

The meter is capable of accepting any voltage from -10 VDC to +10 VDC.

Modbus RTU Serial Communications

Serial communications connection is made to an RJ45 connector labeled M-LINK on Figure 5. For interfacing to the **PROPLUS** use the YPPA1232 for RS-232, the YPPA1485 for RS-485, or the YPPA8008 for USB. The same port is used for interfacing with all expansion modules (e.g. external relays, digital I/O).

Use the YPPA1200 meter copy cable for meter-to-meter interfacing for cloning purposes (i.e. copying settings from one meter to other meters).

Relay Connections

Relay connections are made to two six-terminal connectors labeled RELAY1 – RELAY4 on Figure 5. Each relay's C terminal is common only to the normally open (NO) and normally closed (NC) contacts of the corresponding relay. The relays' C terminals should not be confused with the COM (common) terminal of the INPUT SIGNAL connector.

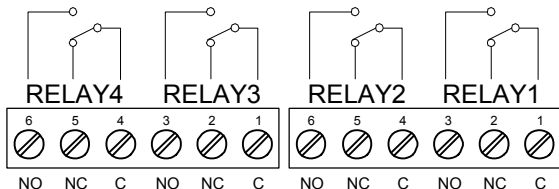

Figure 10. Relay Connections

Switching Inductive Loads

The use of suppressors (snubbers) is strongly recommended when switching inductive loads to prevent disrupting the microprocessor's operation. The suppressors also prolong the life of the relay contacts. Suppression can be obtained with resistor-capacitor (RC) networks assembled by the user or purchased as complete assemblies. Refer to the following circuits for RC network assembly and installation:

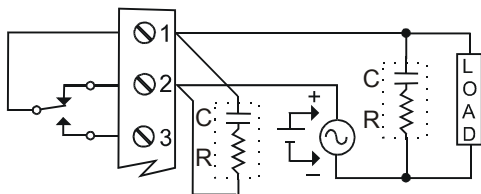

Figure 11. AC and DC Loads Protection

Choose R and C as follows:

R: 0.5 to 1 Ω for each volt across the contacts

C: 0.5 to 1 μF for each amp through closed contacts

Notes:

1. Use capacitors rated for 250 VAC.
2. RC networks may affect load release time of solenoid loads. Check to confirm proper operation.
3. Install the RC network at the meter's relay screw terminals. An RC network may also be installed across the load. Experiment for best results.

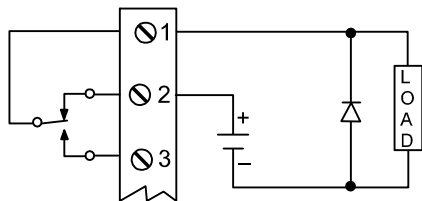

Use a diode with a reverse breakdown voltage two to three times the circuit voltage and forward current at least as large as the load current.

Figure 12. Low Voltage DC Loads Protection

Note: Relays are de-rated to 1/14th HP (50 watts) with an inductive load.

4-20 mA Output Connections

Connections for the 4-20 mA transmitter output are made to the connector terminals labeled MA OUT. The 4-20 mA output may be powered internally or from an external power supply.

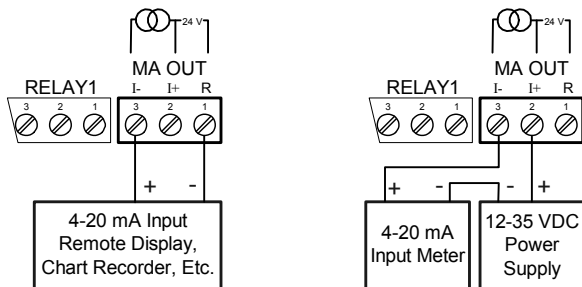

Figure 13. 4-20 mA Output Connections

Analog Output Transmitter Power Supply

The internal 24 VDC power supply powering the analog output may be used to power other devices, if the analog output is not used. The I+ terminal is the +24 V and the R terminal is the return. This power supply is capable of sourcing up to 40 mA.

External Relays & Digital I/O Connections

The relay and the digital I/O expansion modules YPPA1004 & YPPA1044 are connected to the meter using a CAT5 cable provided with each module. The two RJ45 connectors on the expansion modules are identical and interchangeable; they are used to connect additional modules to the system.

Note: The jumper located between the RJ45 connectors of the YPPA1044 must be removed on the second digital I/O module in order for the system to recognize it as module #2.



Warning!

Do not connect or disconnect the expansion modules with the power on!

More detailed instructions are provided with each optional expansion module.

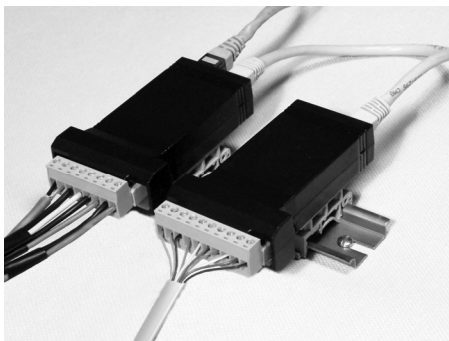

Figure 14. Expansion Modules & DIN Rail Mounting Kit

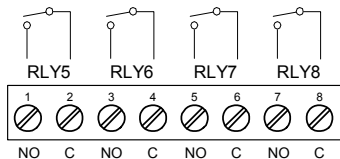

Figure 15. External Relays Module Connections

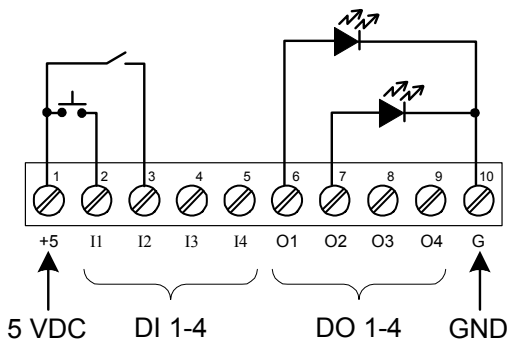

Figure 16. Digital I/O Module Connections

Interlock Relay Feature

As the name implies, the interlock relay feature reassigns one, or more, alarm/control relays for use as interlock relay(s). Interlock contact(s) are wired to digital input(s) and trigger the interlock relay. This feature is enabled by configuring the relay, and relative digital input(s) (see page 62). In one example, dry interlock contacts are connected in series to one digital input which will be used to force on (energize) the assigned interlock power relay when all interlock contacts are closed (safe). The interlock relay front panel LED flashes when locked out. The interlock relay would be wired in-series with the load (N/O contact). See below.

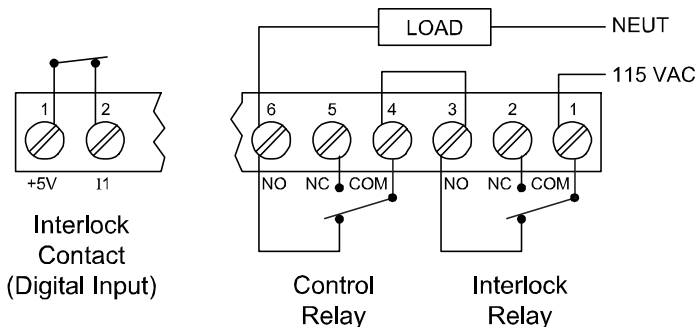

Figure 17. Interlock Connections

SETUP AND PROGRAMMING

The meter is factory calibrated prior to shipment to read in milliamps and volts depending on the input selection. The calibration equipment is certified to NIST standards.

Overview

There are no jumpers to set for the meter input selection.

Setup and programming is done through the front panel buttons.

After power and input signal connections have been completed and verified, apply power to the meter.

Front Panel Buttons and Status LED Indicators



Button Symbol	Description
	Menu
	Right arrow/F1
	Up arrow/F2
	Enter/F3
<p><i>Note:</i> Alarms 5-8 are enabled when relay expansion module is installed.</p>	

LED	Status
1-8	Alarm 1-8 indicator
1-8 M	Flashing: Relay in manual control mode
T	Flashing: Tare
1-4	Flashing: Relay interlock switch open
<p><i>Note:</i> LEDs for relays in manual mode flash with the "M" LED every 10 seconds.</p>	

- Press the Menu button to enter or exit the Programming Mode at any time.
- Press the Right arrow button to move to the next digit during digit or decimal point programming.
- Press or hold the Up arrow button to scroll through the menus, decimal point, or to increment the value of a digit.
- Press the Enter button to access a menu or to accept a setting.
- Press and hold the Menu button for three seconds to access the advanced features of the meter.

Display Functions & Messages

The meter displays various functions and messages during setup, programming, and operation. The following table shows the main menu functions and messages in the order they appear in the menu.

Display	Parameter	Action/Setting Description
rESEt	<i>Reset</i>	Press Enter to access the <i>Reset</i> menu
rSt H i	<i>Reset high</i>	Press Enter to reset max display
rSt Lo	<i>Reset low</i>	Press Enter to reset min display
rSt HL	<i>Reset high & low</i>	Press Enter to reset max & min displays
Control	<i>Control</i>	Enter <i>Control</i> menu
Auto	<i>Automatic</i>	Press Enter to set meter for automatic operation
on An	<i>Manual</i>	Press Enter to manually control relays or analog output operation
SEtUP	<i>Setup</i>	Enter <i>Setup</i> menu
inPUt	<i>Input</i>	Enter <i>Input</i> selection menu
on R	4-20 mA	Set meter for 4-20 mA input
VolT	0-10 VDC	Set meter for ± 10 VDC input
LEVEl	<i>Level</i>	Press Enter to select dual-scale display for level applications (Select Yes or No)
dEc Pt	<i>Decimal point</i>	Set decimal point
Prog	<i>Program</i>	Enter the <i>Program</i> menu
SCALE	<i>Scale</i>	Enter the <i>Scale</i> menu
SCALE 1	<i>Scale 1</i>	Enter the <i>Scale</i> menu for PV1
SCALE 2	<i>Scale 2</i>	Enter the <i>Scale</i> menu for PV2
Cal	<i>Calibrate</i>	Enter the <i>Calibration</i> menu
inP 1	<i>Input 1</i>	Calibrate input 1 signal or program input 1 value
d iS 1	<i>Display 1</i>	Program display 1 value
inP 2	<i>Input 2</i>	Calibrate input 2 signal or program input 2 value (up to 32 points)
d iS 2	<i>Display 2</i>	Program display 2 value (up to 32 points)

Display	Parameter	Action/Setting Description
<i>Error</i>	<i>Error</i>	Error, calibration not successful, check signal or programmed value
<i>PV 1</i>	<i>PV1</i>	PV1 decimal point (Level)
<i>PV 2</i>	<i>PV2</i>	PV2 decimal point (Level)
<i>dSPly</i>	<i>Display</i>	Enter the <i>Display</i> menu
<i>b iG</i>	<i>Big display</i>	Press Enter to assign the Main display parameter (default: PV)
<i>L iEtLE</i>	<i>Little display</i>	Press Enter to assign the small display parameter (default: engineering units)
<i>d PV 1</i>	<i>Display PV1</i>	Assign display to PV1 (Level)
<i>d PV 2</i>	<i>Display PV2</i>	Assign display to PV2 (Level)
<i>d Pct</i>	<i>Display Pct</i>	Assign display to Percent (Level)
<i>d- IntY</i>	<i>Display intensity</i>	Set display intensity level from 1 to 8
<i>rELAY</i>	<i>Relay</i>	Enter the <i>Relay</i> menu
<i>rLY 1</i>	<i>Relay 1</i>	Relay 1 setup
<i>Rct 1</i>	<i>Action 1</i>	Set relay 1 action
<i>Auto</i>	<i>Automatic</i>	Set relay for automatic reset
<i>R-n-Rn</i>	<i>Auto-manual</i>	Set relay for automatic & manual reset any time
<i>LRECH</i>	<i>Latching</i>	Set relay for latching operation
<i>LE-CLR</i>	<i>Latching-cleared</i>	Set relay for latching operation with manual reset only after alarm condition has cleared
<i>ALtErn</i>	<i>Alternate</i>	Set relay for pump alternation control
<i>SRnPL</i>	<i>Sampling</i>	Set relay for sampling operation
<i>OFF</i>	<i>Off</i>	Disable relay and front panel status LED (Select Off to enable Interlock feature)
<i>SEt 1</i>	<i>Set 1</i>	Program set point 1
<i>rSEt 1</i>	<i>Reset 1</i>	Program reset point 1
<i>rLY 2</i>	<i>Relay 2</i>	Relays 2-8 setup <i>Note: Relays 5-8 are shown, only if expansion relay module is installed.</i>

Display	Parameter	Action/Setting Description
<i>FR iLSF</i>	<i>Fail-safe</i>	Enter <i>Fail-safe</i> menu
<i>FLS 1</i>	<i>Fail-safe 1</i>	Set relay 1 fail-safe operation
<i>on</i>	<i>On</i>	Enable fail-safe operation
<i>FLS 2</i>	<i>Fail-safe 2</i>	Set relays 2-8 fail-safe operation
<i>dELAY</i>	<i>Delay</i>	Enter relay <i>Time Delay</i> menu
<i>dLY 1</i>	<i>Delay 1</i>	Enter relay 1 time delay setup
<i>On 1</i>	<i>On 1</i>	Set relay 1 On time delay
<i>OFF 1</i>	<i>Off 1</i>	Set relay 1 Off time delay
<i>dLY 2</i>	<i>Delay 2</i>	Enter relays 2-8 time delay setup
<i>brERH</i>	<i>Loop break</i>	Set relay condition if loop break detected
<i>ignore</i>	<i>Ignore</i>	Ignore loop break condition (Processed as a low signal condition)
<i>On</i>	<i>On</i>	Relay goes to alarm condition when loop break is detected
<i>OFF</i>	<i>Off</i>	Relay goes to non-alarm condition when loop break is detected
<i>Rout</i>	<i>Analog output</i>	Enter the <i>Analog output</i> scaling menu
<i>d iS 1</i>	<i>Display 1</i>	Program display 1 value
<i>Out 1</i>	<i>Output 1</i>	Program output 1 value (e.g. 4.000 mA)
<i>d iS 2</i>	<i>Display 2</i>	Program display 2 value
<i>Out 2</i>	<i>Output 2</i>	Program output 2 value (e.g. 20.000 mA)
<i>PASS</i>	<i>Password</i>	Enter the <i>Password</i> menu
<i>PASS 1</i>	<i>Password 1</i>	Set or enter Password 1
<i>PASS 2</i>	<i>Password 2</i>	Set or enter Password 2
<i>PASS 3</i>	<i>Password 3</i>	Set or enter Password 3
<i>unLoc</i>	<i>Unlocked</i>	Program password to lock meter
<i>Locd</i>	<i>Locked</i>	Enter password to unlock meter
<i>999999</i> <i>-999999</i>	<i>Flashing</i>	Over/under range condition

Main Menu

The main menu consists of the most commonly used functions: *Reset*, *Control*, *Setup*, and *Password*.

- Press Menu button to enter Programming Mode then press the Up arrow button to scroll main menu.

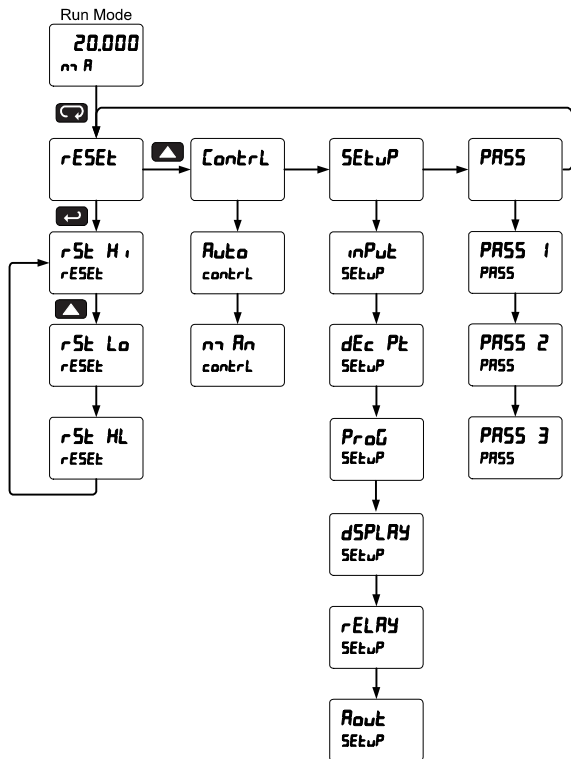

- Press Menu, at any time, to exit and return to Run Mode. Changes made to settings prior to pressing Enter are not saved.
- Changes to the settings are saved to memory only after pressing Enter.
- The display moves to the next menu every time a setting is accepted by pressing Enter.

Setting Numeric Values

The numeric values are set using the Right and Up arrow buttons. Press Right arrow to select next digit and Up arrow to increment digit value.

The digit being changed is displayed brighter than the rest.

Press and hold up arrow to auto-increment the display value.

Press the Enter button, at any time, to accept a setting or Menu button to exit without saving changes.

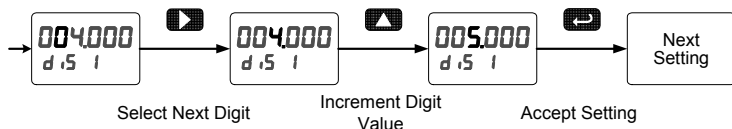

Reset Menu (rESEt)

The *Reset* menu is used to reset the maximum or minimum reading (peak or valley) reached by the process; both may be reset at the same time by selecting "reset high & low" (r5t HL).

Control Menu (ContrL)

The *Control* menu is used to control the 4-20 mA analog output and the relays manually, ignoring the input. Each relay and analog output can be programmed independently for manual control. Selecting automatic control sets all relays and analog output for automatic operation.

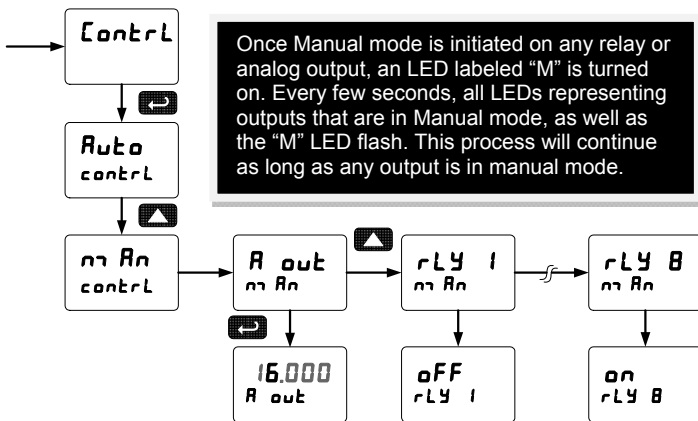

Setting Up the Meter (SEtUP)

The *Setup* menu is used to select:

1. Input signal the meter will accept
2. Dual-scale feature for level applications
3. Decimal point position
4. Display parameter and intensity
5. Relay operation
6. 4-20 mA analog output scaling

Press the Enter button to access any menu or press Up arrow button to scroll through choices. Press the Menu button to exit at any time.

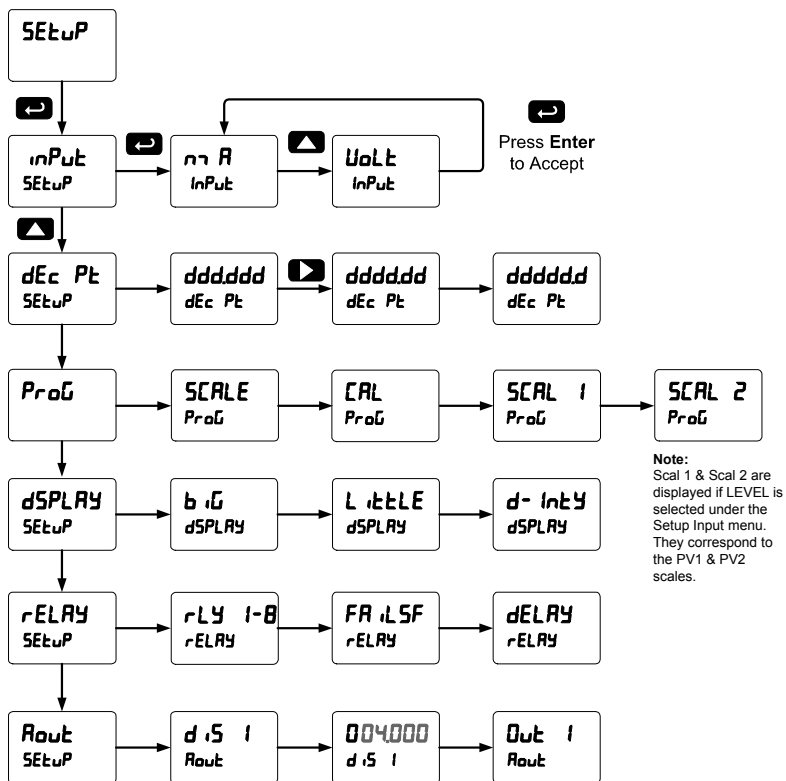

Setting the Input Signal (*inPut*)

Enter the *Input* menu to set up the meter to display current (*mA*) or voltage (*Volt*) inputs.

The current input is capable of accepting any signal from 0 to 20 mA. Select current input to accept 0-20 mA or 4-20 mA signals.

The voltage input is capable of accepting any signal from -10 to +10 VDC. Select voltage input to accept 0-5, 1-5, 0-10, or ± 10 VDC signals.

After selecting *mA* or *Volt* input, *LEVEL* is displayed; press Enter to select “Yes” or “No”. Selecting “Yes” enables the dual-scale feature, allowing scaling the same input in two different scales for PV1 & PV2.

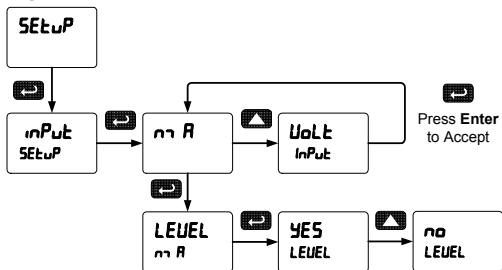

Setting the Decimal Point (*dEc Pt*)

The decimal point may be set with up to five decimal places or with no decimal point at all.

Pressing the Right arrow moves the decimal point one place to the right until no decimal point is displayed, and then it moves to the leftmost position.

If the dual-scale Level feature is selected, the decimal point selections for PV1 & PV2 are enabled.

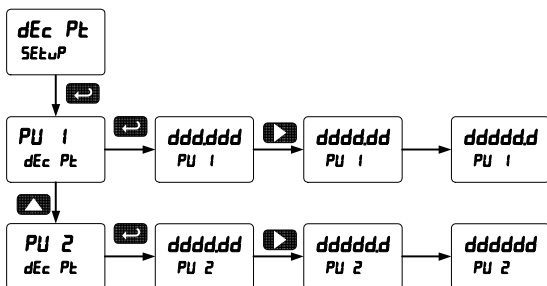

Programming the Meter (*Prog*)

It is **very important** to read the following information, before proceeding to program the meter:

- The meter is factory calibrated prior to shipment to read in milliamps and volts depending on the input selection. The calibration equipment is certified to NIST standards.
- Use the *Scale* menu to scale the process input (e.g. 4-20 mA). A calibrated signal source is not needed to scale the meter.
- Use the *Calibrate* menu to apply a signal from a calibrator or a flowmeter.
- The YPP6000 is a single input meter with dual-scale capability.

The *Program* menu contains the *Scale* and the *Calibrate* menus.

Note: The *Scale* and *Calibrate* functions are exclusive of each other. The meter uses the last function programmed. Only one of these methods can be employed at a time. The *Scale* and *Calibrate* functions can use up to 32 points (default is 2). The number of points should be set in the *Advanced* menu under the Multi-Point Linearization (*Linear*) menu selection prior to scaling and calibration of the meter, see page 72 for details.

If the dual-scale Level feature is selected in the *Setup* menu, the *Scale 1* and *Scale 2* menus are enabled for PV1 & PV2 respectively. The process inputs may be calibrated or scaled to any display value within the range of the meter.

Program Menu for Single Scale Process

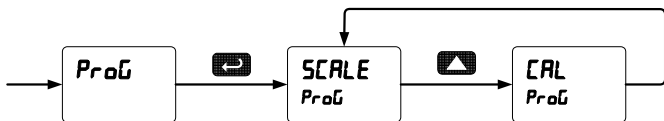

Program Menu for Dual-Scale Level Applications

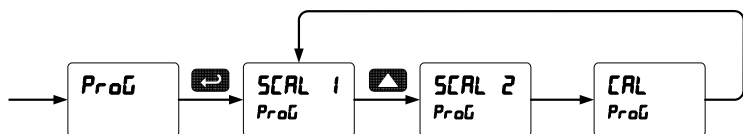

Additional parameters, not needed for most applications, are programmed in the *Advanced Features* menu; see *Advanced Features Menu*, page 66.

Multi-Point Calibration & Scaling

The meter is set up at the factory for 2-point linear calibration. The number of points for multi-point calibration/scaling is set up in the *Advanced Features* menu. Up to 32 linearization points may be selected for PV1 and up to 8 linearization points may be selected for PV2. See page 72 for details.

PROPLUS Software

The meter can also be programmed using the PC-based **PROPLUS** software available for free download at www.yokogawa-usa.com.

Data logging for one meter at the time is available with **PROPLUS** software. More advanced data acquisition may be accomplished by using any Modbus RTU compliant software.

In order to program the meter using a computer, the meter must be connected using a USB, RS-232, or RS-485 serial adapter, see ORDERING INFORMATION on page 7 for details.

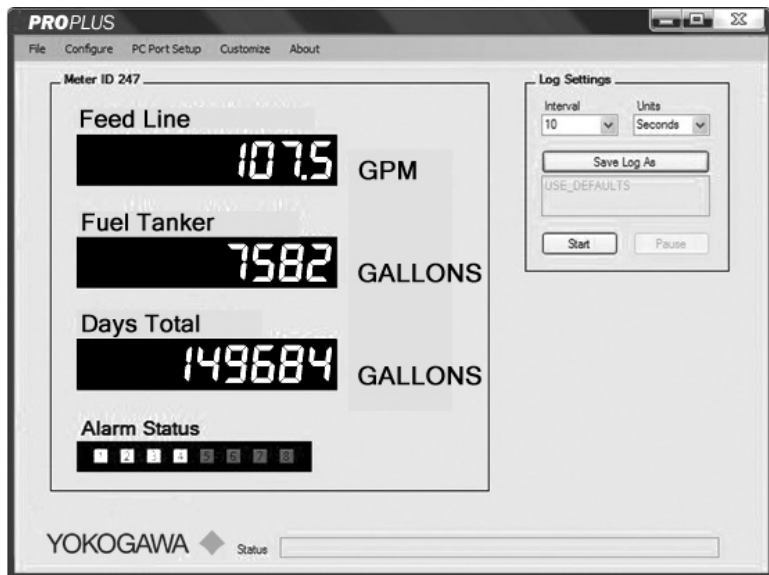

Scaling the Meter (SCALE)

The process input (4-20 mA, ± 10 VDC) can be scaled to display the process variable in engineering units.

A signal source is not needed to scale the meter; simply program the inputs and corresponding display values.

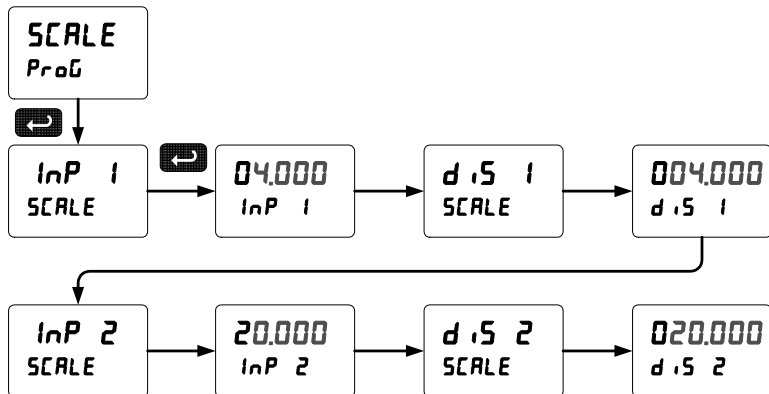

For instructions on how to program numeric values see *Setting Numeric Values*, page 31.

Dual-Scale for Level Application

The analog input can be displayed in two different scales, by enabling the dual-scale feature (LEVEL) in the *Setup Input* menu, see page 33.

To enable the dual-scale feature for level applications you must select LEVEL in the Input selection menu.

Scaling the Input for PV1 (SCAL 1)

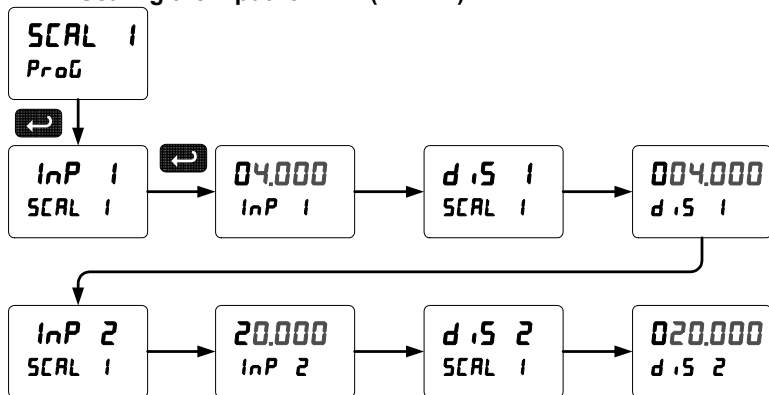

Scaling the Input for PV2 (SCAL 2)

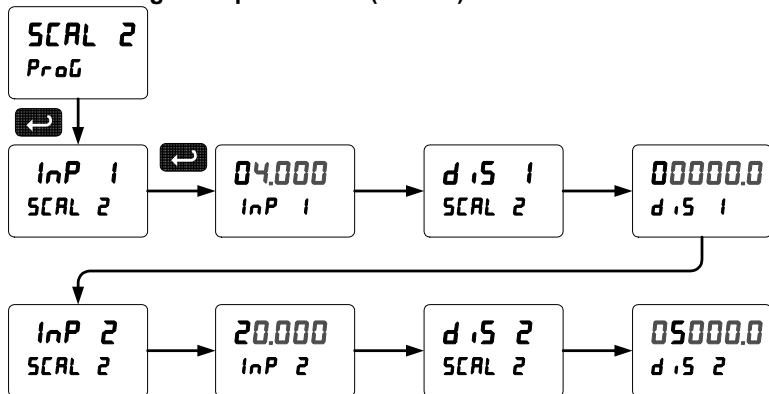

Error Message (Error)

An error message indicates that the calibration or scaling process was not successful.

After the error message is displayed, the meter reverts to input 2 during calibration or scaling and to input 1 during internal calibration, allowing the appropriate input signal to be applied or programmed.

The error message might be caused by any of the following conditions:

1. Input signal is not connected to the proper terminals or it is connected backwards.
2. Wrong signal selection in *Setup* menu.
3. Minimum input span requirements not maintained.
4. Input 1 signal inadvertently applied to calibrate input 2.

Minimum Input Span

The minimum input span is the minimum difference between input 1 and input 2 signals required to complete the calibration or scaling of the meter.

Input Range	Input 1 & Input 2 Span
4-20 mA	0.15 mA
±10 VDC	0.10 VDC

Calibrating the Meter with External Source (CAL)

To scale the meter without a signal source refer to Scaling the Meter (SCALE), page 36.

The meter can be calibrated to display the process variable in engineering units by applying the appropriate input signal and following the calibration procedure.

The use of a calibrated signal source is strongly recommended to calibrate the meter.

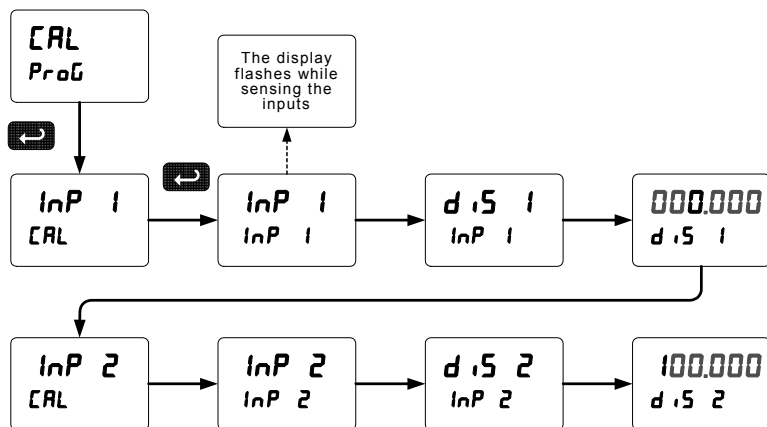

Warm up the meter for at least 15 minutes before performing calibration to ensure specified accuracy.

Setting the Display Parameter & Intensity (dSPLEAY)

The main display (b, d) can be programmed to display:

1. Process value 1 (PV1)
2. Process value 2 (PV2)
3. Percent of PV1 (PCT)
4. Relay set points
5. Max & min values
6. Modbus input
7. Display reading and units

The small display (L, dELE) can be programmed to display:

1. Process value 1 (PV1)
2. Process value 2 (PV2)
3. Percent of PV1 (PCT)
4. Relay set points
5. Max & min values
6. Engineering units or custom legends
7. Modbus input
8. Off (no display)
9. Display reading and units

Display Intensity: The meter has eight display intensity levels to give the best performance under various lighting conditions. Select intensity 8 for outdoor applications.

Display Setup Menu

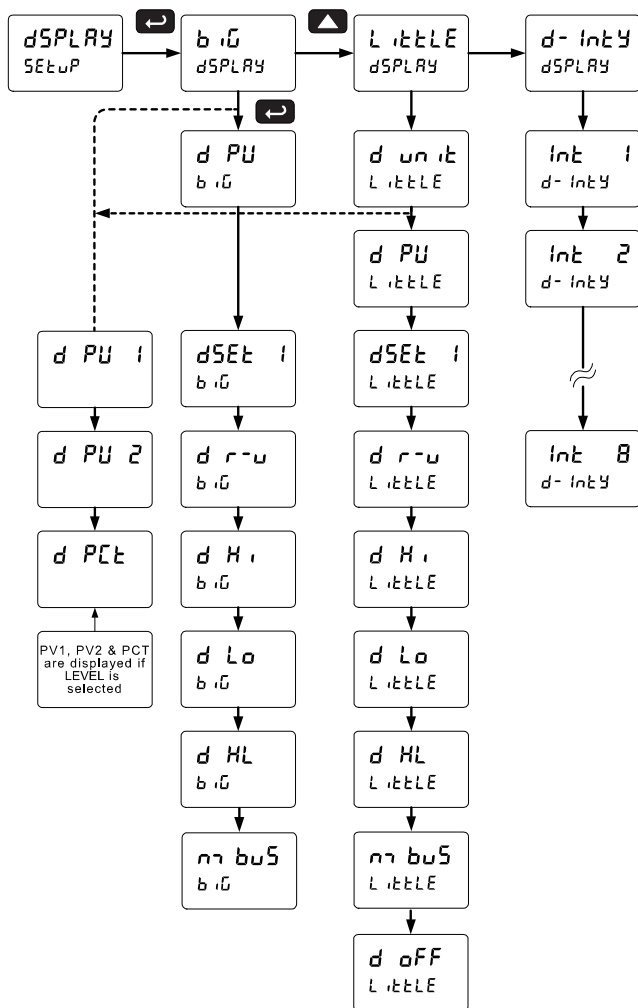

After setting up the input and display, press the Menu button to exit programming and skip the rest of the setup menu. Press the Menu button again and the Up arrow to reach the *Program* menu and complete the scaling or calibration of the meter.

Character Set for Engineering Units Display (d unit)

The small display can be programmed to show engineering units or custom legends using the following 7-segment character set:

Display	Character
0	0
1	1
2	2
3	3
4	4
5	5
6	6
7	7
8	8
9	9
A	A
b	b
C	C
c	c
d	d
E	E
F	F
G	G
g	g
H	H
h	h
I	I
i	i
J	J

Display	Character
K	K
L	L
m	m
n	n
O	O
o	o
P	P
q	q
r	r
S	S
t	t
u	u
V	V
w	w
X	X
Y	Y
Z	Z
-	-
/	/
]]
[[
=	=
	Space
°	Degree

*Degree symbol (special non-ASCII character used)

The letters “m” and “w” use two 7-segment LEDs each; when selected the characters to the right are shifted one position.

See the flow chart on page 41 to access the display units menu.

Press and hold up arrow to auto-scroll the characters in the display.

Setting the Relay Operation (RELAY)

This menu is used to set up the operation of the relays.

CAUTION! *During setup, the relays do not follow the input and they will remain in the state found prior to entering the Relay menu.*

1. Relay action
 - a. Automatic reset only (non-latching)
 - b. Automatic + manual reset at any time (non-latching)
 - c. Latching (manual reset only)
 - d. Latching with Clear (manual reset only after alarm condition has cleared)
 - e. Pump alternation control (automatic reset only)
 - f. Sampling (the relay is activated for a user-specified time)
 - g. Off (relay state controlled by Interlock feature)
2. Set point
3. Reset point
4. Fail-safe operation
 - a. On (enabled)
 - b. Off (disabled)
5. Time delay
 - a. On delay (0-999.9 seconds)
 - b. Off delay (0-999.9 seconds)
6. Relay action for loss (break) of 4-20 mA input (ignore, on, off)

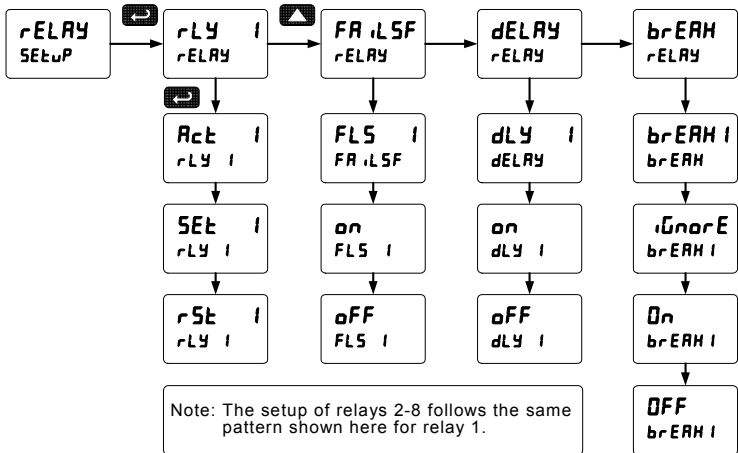

Setting the Relay Action

Operation of the relays is programmed in the *Action* menu. The relays may be set up for any of the following modes of operation:

1. Automatic reset (non-latching)
2. Automatic + manual reset at any time (non-latching)
3. Latching (manual reset only, at any time)
4. Latching with Clear (manual reset only after alarm condition has cleared)
5. Pump alternation control (automatic reset only)
6. Sampling (the relay is activated for a user-specified time)
7. Off (relay state controlled by Interlock feature)

The following graphic shows relay 1 action setup; relay 2-8 are set up in a similar fashion.

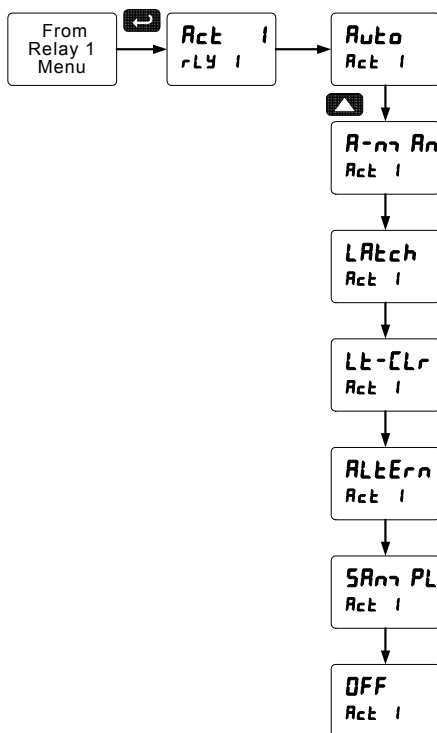

Programming Set and Reset Points

High alarm indication: program set point above reset point.

Low alarm indication: program set point below reset point.

The deadband is determined by the difference between set and reset points. Minimum deadband is one display count. If the set and reset points are programmed with the same value, the relay will reset one count below the set point.

Note: Changes are not saved until the reset point has been accepted.

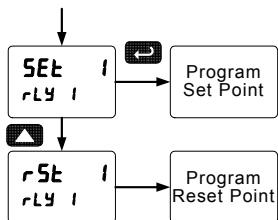

Setting Fail-Safe Operation

In fail-safe mode of operation, the relay coil is energized when the process variable is within safe limits and the relay coil is de-energized when the alarm condition exists. The fail-safe operation is set independently for each relay. Select **on** to enable or select **off** to disable fail-safe operation.

Programming Time Delay

The *On* and *Off* time delays may be programmed for each relay between 0 and 999.9 seconds. The relays will transfer only after the condition has been maintained for the corresponding time delay.

The *On* time delay is associated with the set point.

The *Off* time delay is associated with the reset point.

Relay Action for Loss of 4-20 mA Input (Loop Break)

The loop break feature is associated with the 4-20 mA input. Each relay may be programmed to go to one of the following conditions when the meter detects the loss of the input signal (i.e. < 0.005 mA):

1. Turn *On* (Go to alarm condition)
2. Turn *Off* (Go to non-alarm condition)
3. Ignore (Processed as a low signal condition)

Note: This is not a true loop break condition; if the signal drops below 0.005 mA, it is interpreted as a "loop break" condition.

Relay and Alarm Operation Diagrams

The following graphs illustrate the operation of the relays, status LEDs, and ACK button.

High Alarm Operation (Set > Reset)

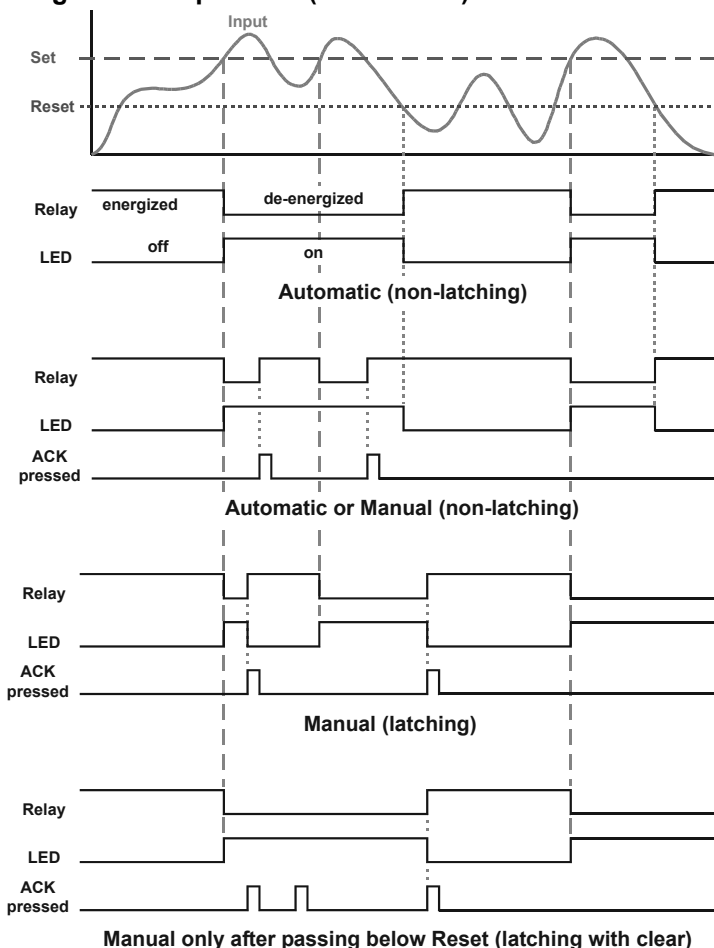

For Manual reset mode, ACK can be pressed anytime to turn "off" relay. To detect a new alarm condition, the signal must go below the set point, and then go above it.

Low Alarm Operation (Set < Reset)

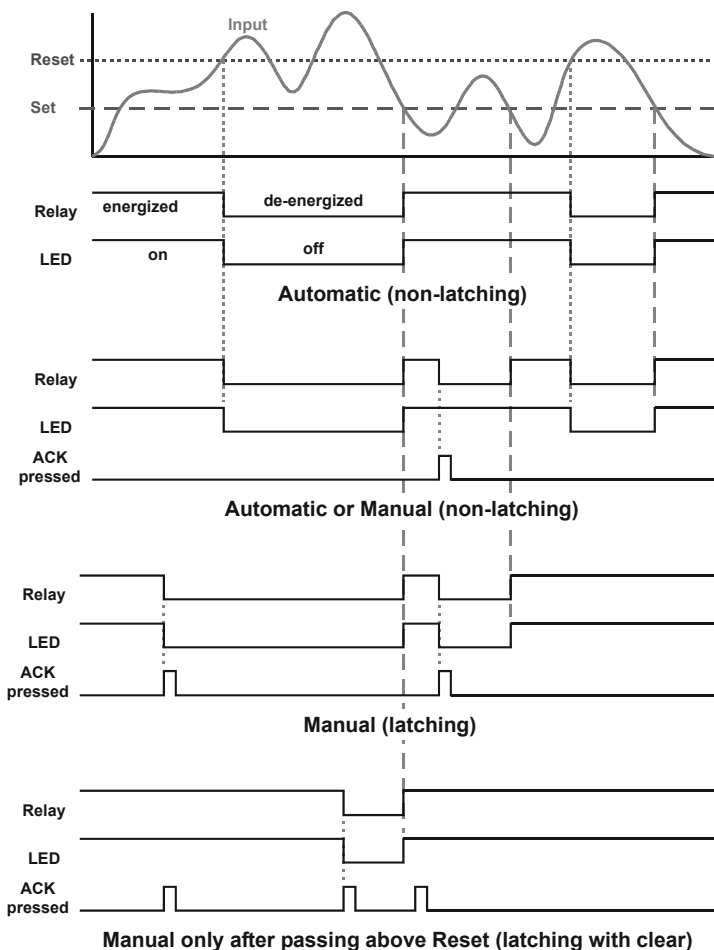

For Manual reset mode, ACK can be pressed anytime to turn "off" relay. For relay to turn back "on", signal must go above set point, and then go below it.

High Alarm with Fail-Safe Operation (Set > Reset)

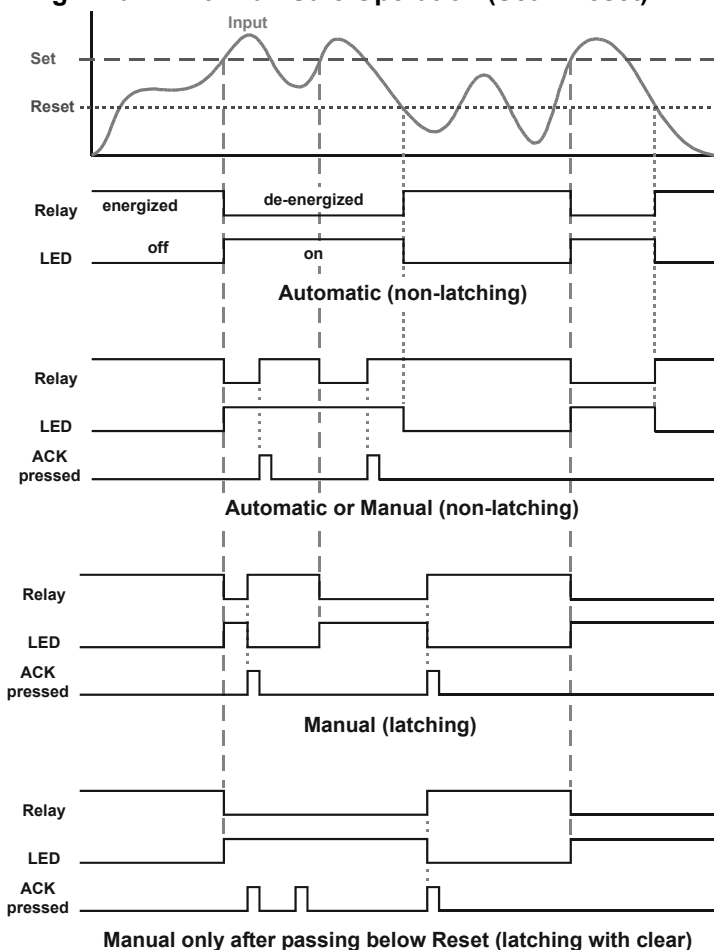

*Note: Relay coil is energized in non-alarm condition.
In case of power failure, relay will go to alarm state.*

Low Alarm with Fail-Safe Operation (Set < Reset)

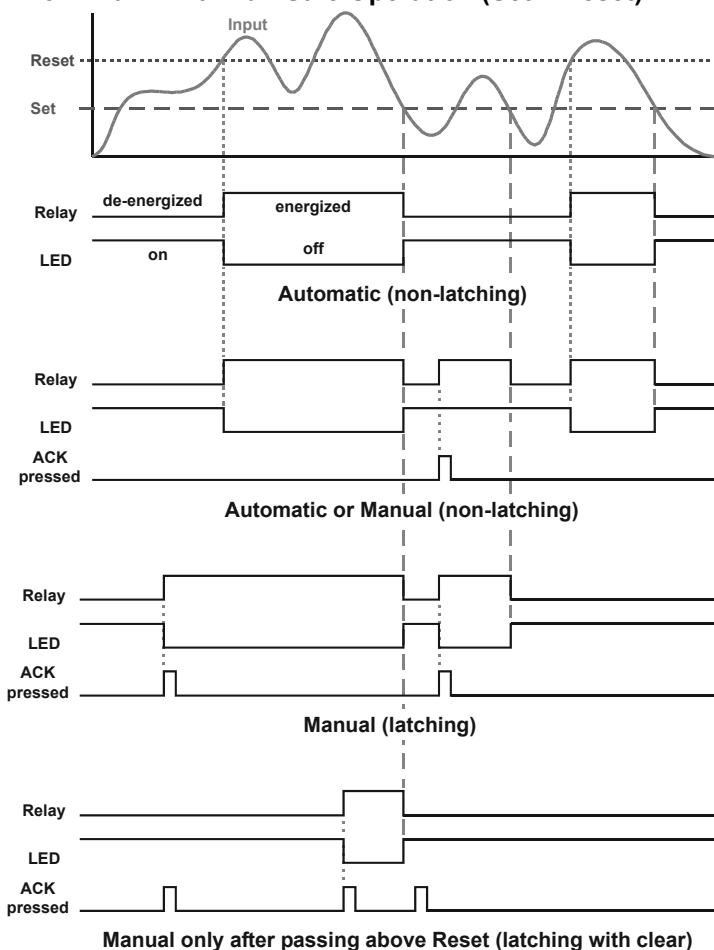

*Note: Relay coil is energized in non-alarm condition.
In case of power failure, relay will go to alarm state.*

Pump Alternation Control Operation

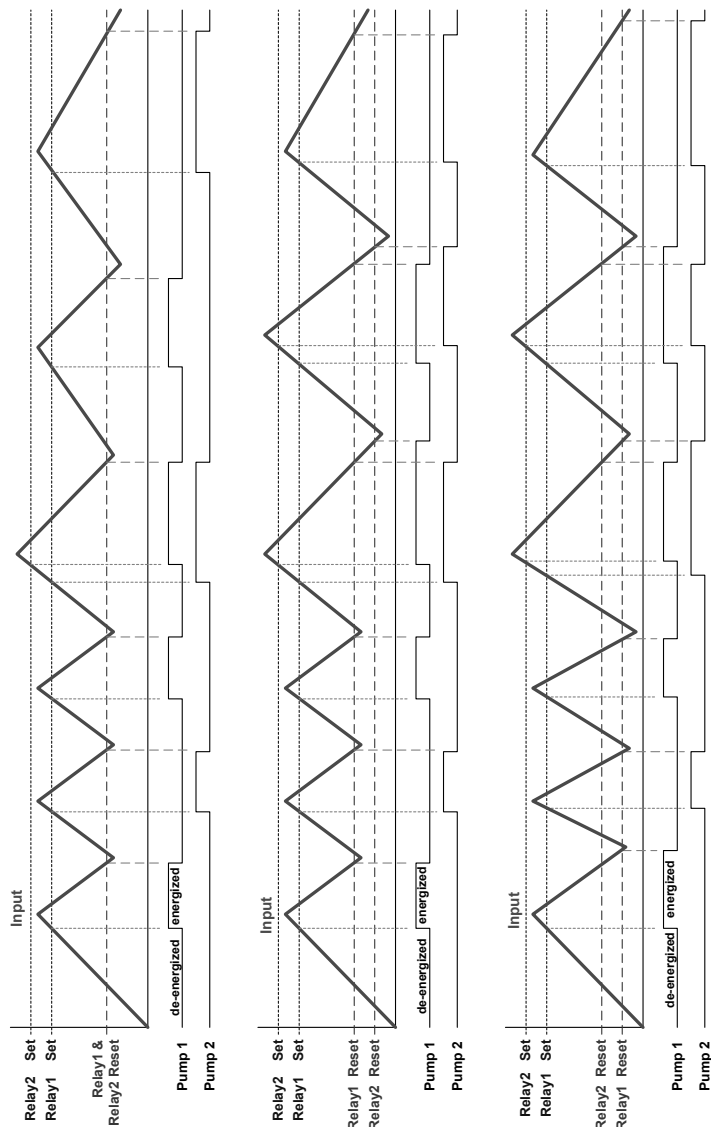

Relay Sampling Operation

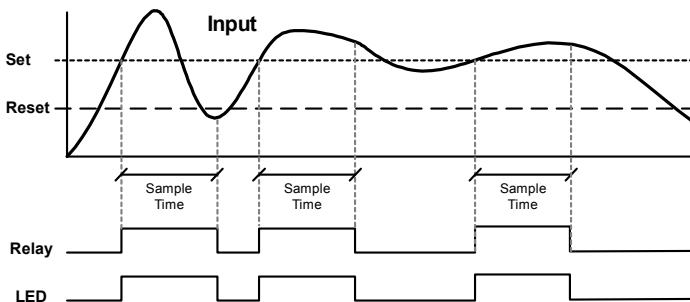

When the signal crosses the set point, the relay trips and the sample time starts. After the sample time has elapsed, the relay resets. The cycle repeats every time the set point is crossed, going up for high alarms and going down for low alarms.

The sample time can be programmed between 0.1 and 5999.9 seconds.

Signal Loss or Loop Break Relay Operation

The following graph shows the loop break relay operation for a high alarm relay.

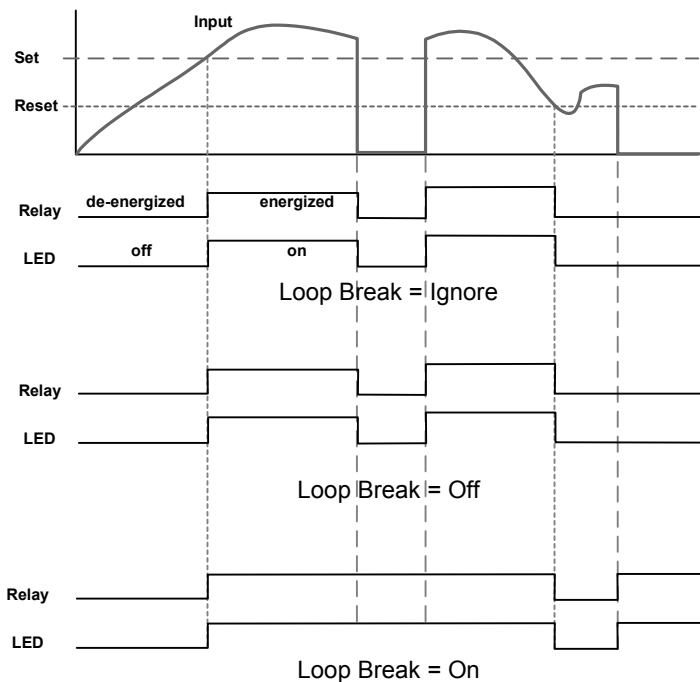

When the meter detects a break in the 4-20 mA loop, the relay will go to one of the following selected actions:

1. Turn *On* (Go to alarm condition)
2. Turn *Off* (Go to non-alarm condition)
3. Ignore (Processed as a low signal condition)

Time Delay Operation

The following graphs show the operation of the time delay function.

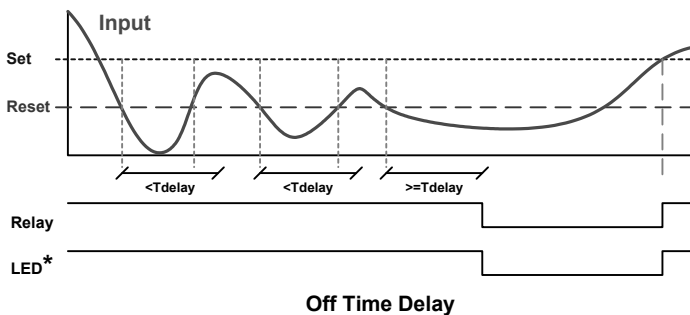
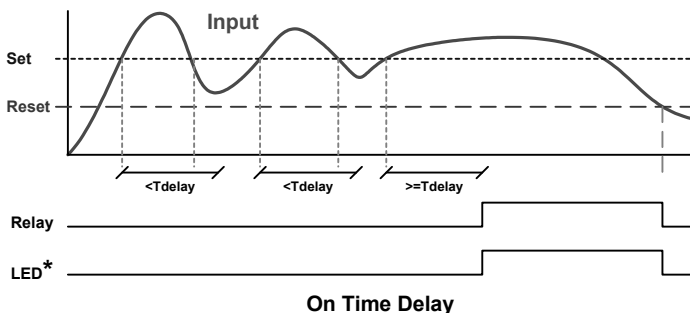

When the signal crosses the set point, the *On* time delay timer starts and the relay trips when the time delay has elapsed. If the signal drops below the set point (high alarm) before the time delay has elapsed, the *On* time delay timer resets and the relay does not change state. The same principle applies to the *Off* time delay.

* Note: If “*Automatic or Manual (A-nn An)*” reset mode is selected, the LED follows the reset point and not the relay state when the relay is acknowledged.

Relay Operation Details

Overview

The relay capabilities of the meter expand its usefulness beyond simple indication to provide users with alarm and control functions. These capabilities include front panel alarm status LEDs as well as either 2 or 4 optional internal relays and/or 4 external relays expansion module. Typical applications include high or low temperature, level, pressure or flow alarms, control applications such as simple on/off pump control, and pump alternation control for up to 8 pumps. There are four basic ways the relays can be used:

1. High or Low Alarms with Latching or Non-Latching Relays
2. Simple On/Off Control with 100% Adjustable Deadband
3. Sampling (Based on Time)
4. Pump Alternation Control for up to 8 Pumps

Relays Auto Initialization

When power is applied to the meter, the front panel LEDs and alarm relays will reflect the state of the input to the meter. The following table indicates how the alarm LEDs and relays will react on power-up based on the set and reset points:

Alarm #	HI or LO Alarm	Set Point	Reset Point	Power-Up Reading	Relay & LED
1	HI	1000	500	499	Off
2	LO	700	900	499	On
3	LO	250	400	499	Off
4	HI	450	200	499	On

Fail-Safe Operation

The following table indicates how the relays behave based on the fail-safe selection for each relay:

Fail-Safe Selection	Non-Alarm State		Alarm State		Power Failure
	NO	NC	NO	NC	
Off	Open	Closed	Closed	Open	Relays go to non-alarm state
On	Closed	Open	Open	Closed	Relays go to alarm state

Note: NO = Normally Open, NC = Normally Closed. This refers to the condition of the relay contacts when the power to the meter is off.

Front Panel LEDs

The LEDs on the front panel provide status indication for the following:

LED	Status
1	Alarm 1
2	Alarm 2
3	Alarm 3
4	Alarm 4

LED	Status
5	Alarm 5
6	Alarm 6
7	Alarm 7
8	Alarm 8

The meter is supplied with four alarm points that include front panel LEDs to indicate alarm conditions. This standard feature is particularly useful for alarm applications that require visual-only indication. The LEDs are controlled by the set and reset points programmed by the user. When the display reaches a set point for a high or low alarm, the corresponding alarm LED will turn on. When the display returns to the reset point the LED will go off. The front panel LEDs respond differently for latching and non-latching relays.

For non-latching relays, the LED is always off during normal condition and always on during alarm condition, regardless of the state of the relay (e.g. Relay acknowledged after alarm condition).

For latching relays, the alarm LEDs reflect the status of the relays, regardless of the alarm condition. The following tables illustrate how the alarm LEDs function in relation to the relays and the acknowledge button (Default: F3 key assigned to ACK):

Latching and Non-Latching Relay Operation

The relays can be set up for latching (manual reset) or non-latching (automatic reset) operation.

Relay terminology for following tables

Terminology	Relay Condition
On	Alarm (Tripped)
Off	Normal (Reset)
Ack	Acknowledged

The On and Off terminology does not refer to the status of the relay's coil, which depends on the fail-safe mode selected.



In latching relay mode, latched relays will reset (unlatch) when power is cycled.

Warning!

Non-Latching Relay (R_uL_o)**Automatic reset only**

Condition	LED	Relay
Normal	Off	Off
Alarm	On	On
Ack (No effect)	On	On
Normal	Off	Off

In this application, the meter is set up for automatic reset (non-latching relay). Acknowledging the alarm while it is still present has no effect on either the LED or the relay. When the alarm finally goes away, the relay automatically resets and the LED also goes off.

Non-Latching Relay (R_n-_n R_n)**Automatic + manual reset at any time**

Condition	LED	Relay
Normal	Off	Off
Alarm	On	On
Normal	Off	Off
Next Alarm	On	On
Ack	On	Off
Normal	Off	Off

In this application, the meter is set up for automatic and manual reset at any time (non-latching relay). The LED and the relay automatically reset when the meter returns to the normal condition.

The next time an alarm occurs, the operator acknowledges the alarm manually while the alarm condition still exists. This causes the relay to reset, but the LED stays on until the meter returns to the normal condition.

Latching Relay (L_RL_oH)**Manual reset any time**

Condition	LED	Relay
Normal	Off	Off
Alarm	On	On
Ack	Off	Off

In this application, the meter is set up for manual reset at any time. Acknowledging the alarm even if the alarm condition is still present resets the relay and turns off the LED.

Latching Relay (L_L-L_r)

Manual reset only after alarm condition has cleared

Condition	LED	Relay
Normal	Off	Off
Alarm	On	On
Ack (No effect)	On	On
Normal	On	On
Ack	Off	Off

In this application, the meter is set up for manual reset only after the signal passes the reset point (alarm condition has cleared).

Acknowledging the alarm while it is still present has no effect on either the LED or the relay. When the alarm is acknowledged after it returns to the normal state, the LED and the relay go off. Notice that the LED remains on, even after the meter returns to the normal condition. This is because, for latching relays, the alarm LED reflects the status of the relay, regardless of the alarm condition.

Acknowledging Relays

There are two ways to acknowledge relays programmed for manual reset: via the programmable front panel function keys F1-F3 (Default: F3 assigned to ACK) and remotely via a normally open pushbutton wired across one of the digital inputs and the +5 V terminals on the digital I/O modules (Default: DI-4 assigned to ACK). When the ACK button or the assigned digital input is closed, all relays programmed for manual reset are acknowledged.

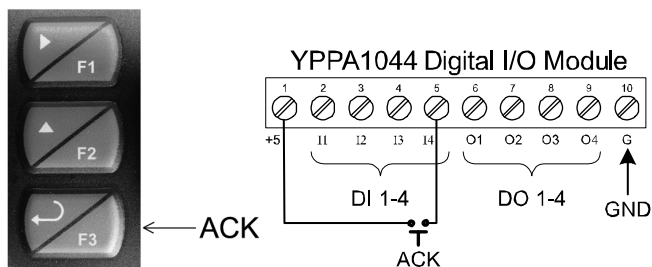

Figure 18. Acknowledge Relays w/Function Key or Digital Input

Pump Alternation Control Applications (ALtErn)

For pump control applications where two or more similar pumps are used to control the level of a tank or a well, it is desirable to have all the pumps operate alternately. This prevents excessive wear and overheating of one pump over the lack of use of the other pumps.

Up to 8 relays can be set up to alternate every time an on/off pump cycle is completed. The set points and reset points can be programmed, so that the first pump on is the first pump off.

Application #1: Pump Alternation Using Relays 1 & 2

1. Relays 1 and 2 are set up for pump alternation.
2. Relays 3 and 4 are set up for low and high alarm indication.

Set and Reset Point Programming

Relay	Set Point	Reset Point	Function
1	30.000	10.000	Controls pump #1
2	35.000	5.000	Controls pump #2
3	4.000	9.000	Controls low alarm
4	40.000	29.000	Controls high alarm

Pump Alternation Operation

1. Pump #1 turns on when level reaches 30.000, when level drops below 10.000, pump #1 turns off.
2. The next time level reaches 30.000, pump #2 turns on, when level drops below 10.000, pump #2 turns off.
3. If the level doesn't reach 35.000, pump #1 and pump #2 will be operating alternately.
4. If pump #1 cannot keep the level below 35.000, pump #2 will turn on at 35.000, then as the level drops to 10.000, pump #1 turns off, pump #2 is still running and shuts off below 5.000.
5. Notice that with the set and reset points of pump #2 outside the range of pump #1, the first pump on is the first pump to go off. This is true for up to 8 alternating pumps, if setup accordingly.
6. Relay #3 will go into alarm if the level drops below 4.000 and relay #4 will go into alarm if the level exceeds 40.000.
7. Adding the 4 external relays, expansion module allows using the 4 SPDT internal relays for pump alternation and the 4 SPST external relays for high, high-high, low, and low-low alarm indication.

Application #2: Pump Alternation Using Relays 3 & 4

1. Relays 1 and 2 are set up for low and high alarm indication.
2. Relays 3 and 4 are set up for pump alternation.

Set and Reset Point Programming

Relay	Set Point	Reset Point	Function
1	495	750	Controls low alarm
2	7500	6900	Controls high alarm
3	7000	900	Controls backup pump
4	6000	1000	Controls main pump

The following graphics provide a visual representation of a typical pump alternation application with high and low alarm monitoring:

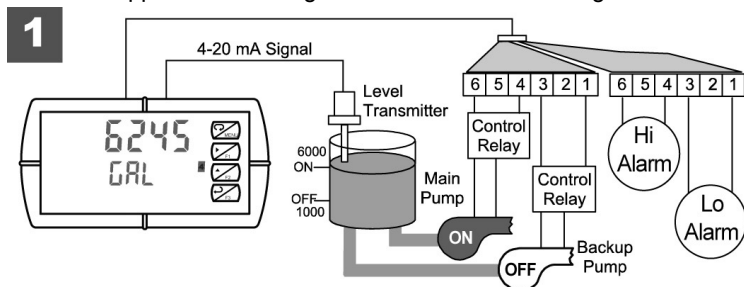

1. Relay #4 turns the main pump on at 6000 gallons and turns it off at 1000 gallons.

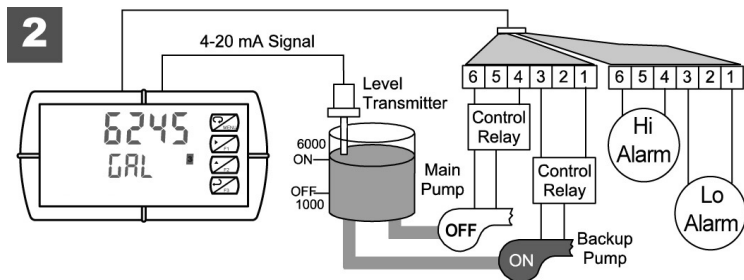

2. With the Pump Alternation feature activated, the next time the level reaches 6000 gallons, relay #3 transfers and starts the backup pump.

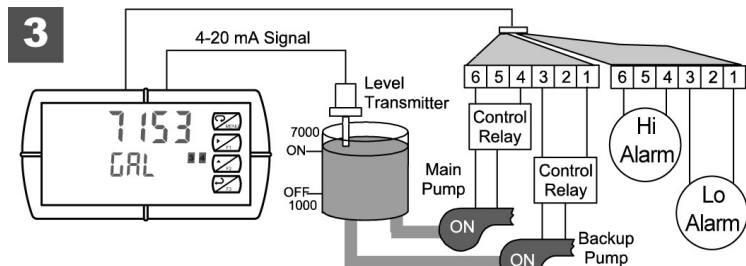

3. If the backup pump is not able to keep up, and the level reaches 7000 gallons, relay #4 transfers and starts the main pump as well.

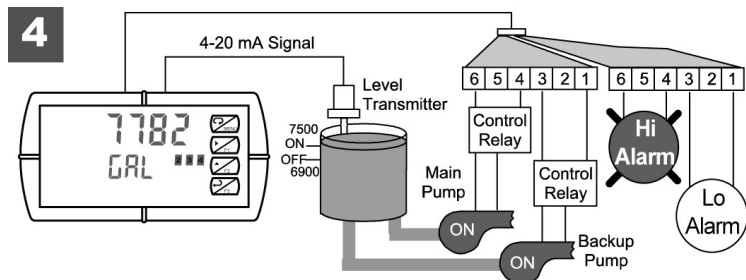

4. Relay #2 trips the High Level Alarm at 7500 gallons and resets at 6900 gallons.

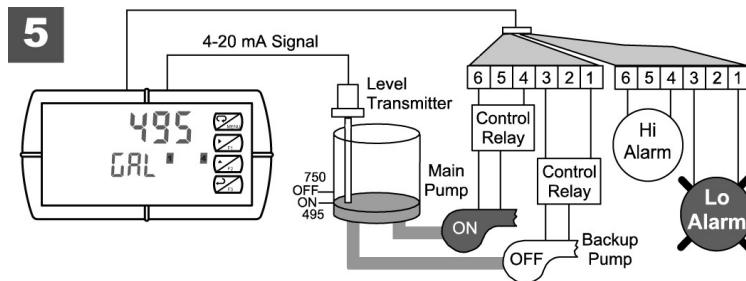

5. Relay #1 trips the Low Level Alarm at 495 gallons and resets at 750 gallons.

Setting Up the Interlock Relay (Force On) Feature

Relays 1-4 can be set up as interlock relays. To set up the relays for the interlock feature:

1. Access the *Setup – Relay – Action* menu and set the action to off.

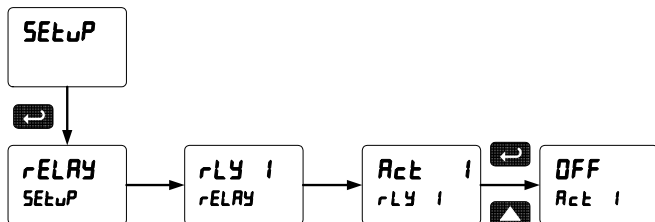

2. In the Advanced features – *User* menu program any of the digital inputs to *Force On* any of the internal relays (1-4).

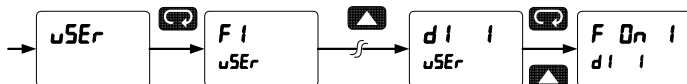

3. Connect a switch or dry contact between the +5V terminal and the corresponding digital input (dl-1 to dl-4) terminal.

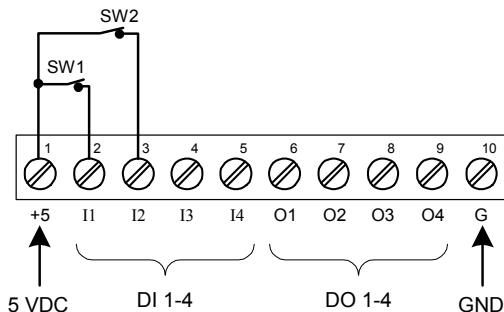

Interlock Relay Operation Example

Relays 1 & 2 are configured to energize (their front panel LEDs are off) when SW1 & SW2 switches (above) are closed. If the contacts to these digital inputs are opened, the corresponding front panel LEDs flash indicating this condition. The processes being controlled by the interlock relay will stop, and will re-start only after the interlock relay is re-activated by the digital inputs (switches).

Scaling the 4-20 mA Analog Output (*Rout*)

The 4-20 mA analog output can be scaled to provide a 4-20 mA signal for any display range selected.

No equipment is needed to scale the analog output; simply program the display values to the corresponding mA output signal.

The *Analog Output* menu is used to program the 4-20 mA output based on display values.

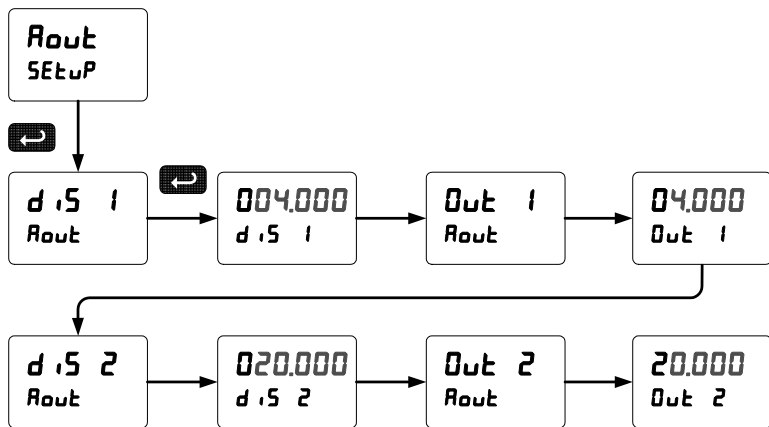

For instructions on how to program numeric values see *Setting Numeric Values*, page 31.

Setting Up the Password (PASS)

The *Password* menu is used for programming three levels of security to prevent unauthorized changes to the programmed parameter settings.

Pass 1: Allows use of function keys and digital inputs

Pass 2: Allows use of function keys, digital inputs and editing set/reset points

Pass 3: Restricts all programming, function keys, and digital inputs.

Protecting or Locking the Meter

Enter the *Password* menu and program a six-digit password.

For instructions on how to program numeric values see *Setting Numeric Values*, page 31.

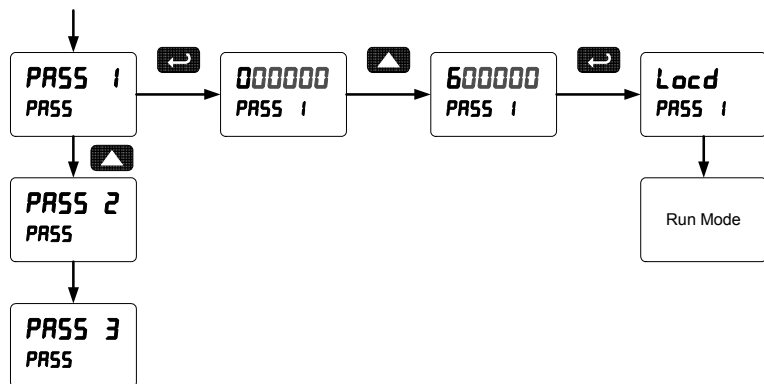

Record the password for future reference. If appropriate, it may be recorded in the space provided.

Model:	
Serial Number:	
Password 1:	__ _ _ _ _
Password 2:	__ _ _ _ _
Password 3:	__ _ _ _ _

Making Changes to a Password Protected Meter

If the meter is password protected, the meter will display the message *Locd* (*Locked*) when the Menu button is pressed. Press the Enter button while the message is being displayed and enter the correct password to gain access to the menu. After exiting the programming mode, the meter returns to its password protected condition.

Disabling Password Protection

To disable the password protection, access the *Password* menu and enter the correct password twice, as shown below. The meter is now unprotected until a new password is entered.

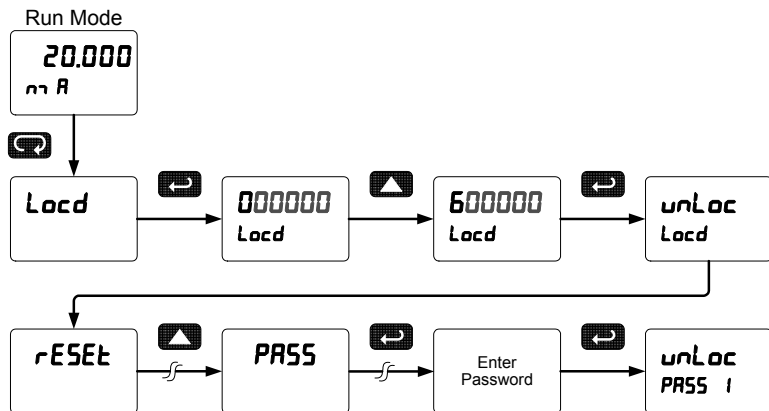

If the correct six-digit password is entered, the meter displays the message *unLoc* (*unlocked*) and the protection is disabled until a new password is programmed.

If the password entered is incorrect, the meter displays the message *Locd* (*Locked*) for about two seconds, and then it returns to Run Mode. To try again, press Enter while the *Locked* message is displayed.

Did you forget the password?

The password may be disabled by entering a master password once. If you are authorized to make changes, enter the master password 508655 to unlock the meter.

Advanced Features Menu

To simplify the setup process, functions not needed for most applications are located in the *Advanced Features* menu.

Press and hold the Menu button for three seconds to access the advanced features of the meter.

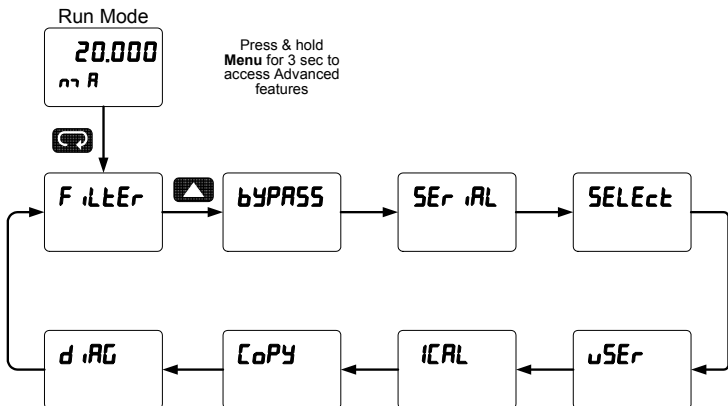

Advanced Features Menu & Display Messages

The following table shows the functions and messages of the *Advanced Features* menu in the order they appear in the menu.

Display	Parameter	Action/Setting
<i>F ILtEr</i>	<i>Filter</i>	Set noise filter value
<i>bYPASS</i>	<i>Bypass</i>	Set filter bypass value
<i>SER iAL</i>	<i>Serial</i>	Set serial communication parameters
<i>SLAVE ID</i>	<i>Slave ID</i>	Set slave ID or meter address
<i>bAud</i>	<i>Baud rate</i>	Select baud rate
<i>t r dLY</i>	<i>Transmit delay</i>	Set transmit delay for serial communication
<i>PAR iTY</i>	<i>Parity</i>	Select parity Even, Odd, or None with 1 or 2 stop bits
<i>t-bytE</i>	<i>Time byte</i>	Set byte-to-byte timeout
<i>SELEct</i>	<i>Select</i>	Enter the Select menu (function, cutoff, out)
<i>FunctiOn</i>	<i>Signal input conditioning</i>	Select linear, square root, programmable exponent, or round horizontal tank function
<i>LiNEAR</i>	<i>Linear</i>	Set meter for linear function and select number of linearization points
<i>PV 1</i>	<i>PV1</i>	Select PV1 number of linearization points
<i>PV 2</i>	<i>PV2</i>	Select PV2 number of linearization points
<i>no Pts</i>	<i>Number of points</i>	Set PV1 for 2 to 32-point linearization Set PV2 for 2 to 8-point linearization
<i>SqUARE</i>	<i>Square root</i>	Set meter for square root extraction
<i>Prog E</i>	<i>Programmable exponent</i>	Set meter for programmable exponent and enter exponent value
<i>rhE</i>	<i>Round horizontal tank</i>	Set meter for round horizontal tank volume calculation
<i>d r-u</i>	<i>Display</i>	Select to display reading and units
<i>d iAm r</i>	<i>Diameter</i>	Enter the tank's diameter in inches
<i>LEnGth</i>	<i>Length</i>	Enter the tank's length in inches
<i>CuToFF</i>	<i>Cutoff</i>	Set low-flow cutoff
<i>ANALog Pr</i>	<i>Analog output programming</i>	Program analog output parameters

Display	Parameter	Action/Setting
SOURCE	Source	Select source for the 4-20 mA output
OVERRNG	Overrange	Program mA output for display overrange
UNDRNG	Underrange	Program mA output for display underrange
MAX RH	Maximum	Program maximum mA output allowed
MIN LH	Minimum	Program minimum mA output allowed
CALIB	Calibrate	Calibrate 4-20 mA output (internal reference source used for scaling the output)
4 mA R	4 mA output	Enter mA output value read by milliamp meter with at least 0.001 mA resolution
20 mA R	20 mA output	Enter mA output value read by milliamp meter with at least 0.001 mA resolution
USER	User I/O	Assign function keys and digital I/O
F1	F1 function key	Assign F1 function key
F2	F2 function key	Assign F2 function key
F3	F3 function key	Assign F3 function key
d I 1	Digital input 1	Assign digital input 1 – 8, if expansion modules are connected
d O 1	Digital output 1	Assign digital output 1 – 8, if expansion modules are connected
ICAL	Internal source calibration	Enter internal source calibration (used for scaling the meter without a signal source)
C CAL	Current calibration	Calibrate 4-20 mA current input (internal reference source used for scaling the input)
C Lo	Current low	Calibrate low current input (e.g. 4 mA)
C Hi	Current high	Calibrate high current input (e.g. 20 mA)
V CAL	Voltage calibration	Calibrate voltage input
V Lo	Voltage low	Calibrate low voltage input (e.g. 0 V)
V Hi	Voltage high	Calibrate high voltage input (e.g. 10 V)
COPY	Copy	Enter copy function
SEND	Send	Send meter settings to another meter

Display	Parameter	Action/Setting
<i>donE</i>	<i>Done</i>	Copy function completed
<i>d iAG</i>	<i>Diagnostics</i>	Display parameter settings
<i>inPut</i>	<i>Input</i>	Input selection
<i>F iLEr</i>	<i>Filter</i>	Filter value
<i>bYPASS</i>	<i>Bypass</i>	Bypass value
<i>FunctiOn</i>	<i>Function</i>	Function selected
<i>SCALE</i>	<i>Scale</i>	Scaling parameter
<i>CuTOff</i>	<i>Cutoff</i>	Cutoff value
<i>dSPLY</i>	<i>Display</i>	Display assignments
<i>rELAY</i>	<i>Relays</i>	Relay settings
<i>RoUt</i>	<i>Analog output</i>	Analog output scaling
<i>RoUtPr</i>	<i>Analog output programming</i>	Analog output programming
<i>SEr iAL</i>	<i>Serial</i>	Serial communication settings
<i>LEd t</i>	<i>LED test</i>	Test all LEDs
<i>inFo</i>	<i>Information</i>	Display software and S/N information

Noise Filter (*F iLEr*)

The noise filter is available for unusually noisy signals that cause an unstable process variable display. The noise filter averages the input signal over a certain period. The filter level determines the length of time over which the signal is averaged. The filter level can be set between 2 and 199. The higher the filter level, the longer the averaging time and so the longer it takes the display to settle to its final value. Setting the filter level to zero disables the filter function.

Noise Filter Bypass (*bYPASS*)

The noise filter bypass changes the behavior of the meter so that small variations in the signal are filtered out but large abrupt changes in the input signal are displayed immediately. The bypass value determines the minimum amount of signal change to be displayed immediately. All signal changes smaller than the bypass value are filtered or averaged by the meter. The noise filter bypass may be set between 0.1 and 99.9% of full scale.

Modbus RTU Serial Communications (SEr, AL)

The meter is equipped with serial communications capability as a standard feature using Modbus RTU Serial Communication Protocol.

To communicate with a computer or other data terminal equipment, an RS-232 or RS-485 adapter option is required; see *Ordering Information* on page 7 for details.



Warning!

Do not connect any equipment other than Yokogawa's expansion modules, cables, or meters to the RJ45 M-LINK connector. Otherwise damage will occur to the equipment and the meter.

Note: More detailed instructions are provided with each optional serial communications adapter.

*Note: Refer to the **PROPLUS** Modbus Register Tables located at www.yokogawa-usa.com for details.*

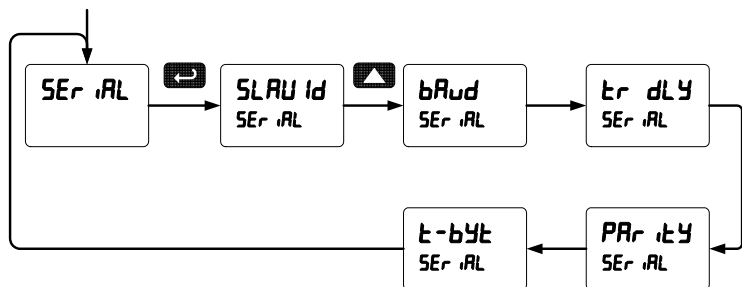

When using more than one meter in a multi-drop mode, each meter must be provided with its own unique address. The meter address (Slave ID) may be programmed between 1 and 247. The transmit delay may be set between 0 and 199 ms. The parity can be set to even, odd, or none with 1 or 2 stop bits.

The YPP6000 can also be connected to another YPP6000 with a special YPPA1200 cable, allowing the user to copy all the settings from one meter to another, using the *Copy* function.

Select Menu (SELEct)

The *Select* menu is used to select the signal input conditioner applied to the input (linear, square root, programmable exponent, or round horizontal tank), low-flow cutoff, and analog output programming. The multi-point linearization is part of the linear function selection.

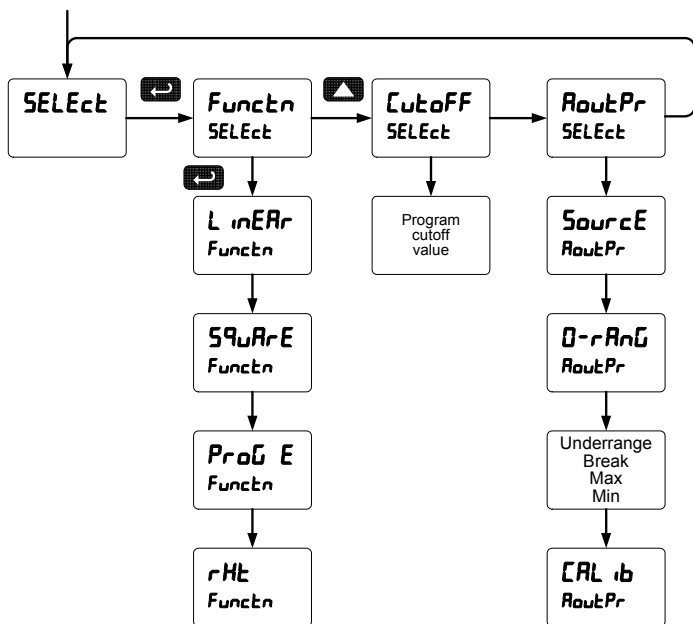

Signal Input Conditioning (Functn)

The *Function* menu is used to select the signal input conditioner applied to the input: linear, square root, programmable exponent, or round horizontal tank volume calculation. The multi-point linearization is part of the linear function selection.

Meters are set up at the factory for linear function with 2-point linearization. The linear function provides a display that is linear with respect to the input signal.

Square Root Linearization (SQUR E)

The square root function can be used to linearize the signal from a differential pressure transmitter and display flow rate in engineering units.

Programmable Exponent Linearization (PROG E)

The programmable exponent can be used to linearize the signal from level transmitters in open-channel flow applications using weirs and flumes.

Multi-Point Linearization (LINEAR)

Meters are set up at the factory for linear function with 2-point linearization. Up to 32 linearization points can be selected for PV1 under the linear function. The multi-point linearization can be used to linearize the display for non-linear signals such as those from level transmitters used to measure volume in odd-shaped tanks or to convert level to flow using weirs and flumes with complex exponent.

If the dual-scale Level feature has been selected, the menus for PV1 & PV2 are enabled. PV2 can be programmed with up to 8 linearization points.

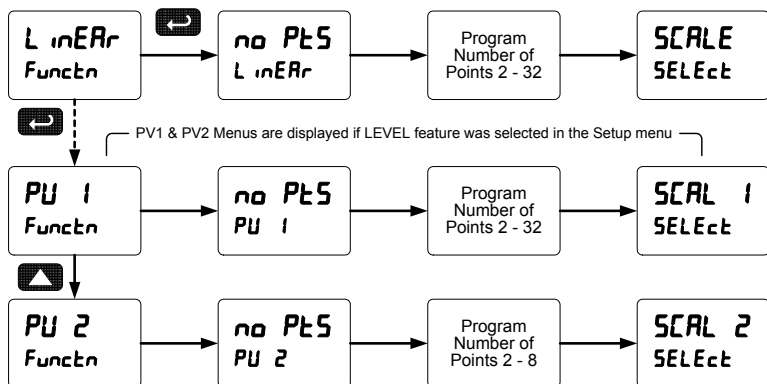

Round Horizontal Tank Linearization (rHt)

This function automatically calculates the volume in a round horizontal tank with flat ends.

Set the display for the desired decimal point and engineering units before entering the round horizontal tank function. Select units, inches or cm for the tank dimensions. Enter the diameter and the length in inches and the results are calculated automatically in US gallons.

The meter can be scaled to display the volume in any engineering unit.

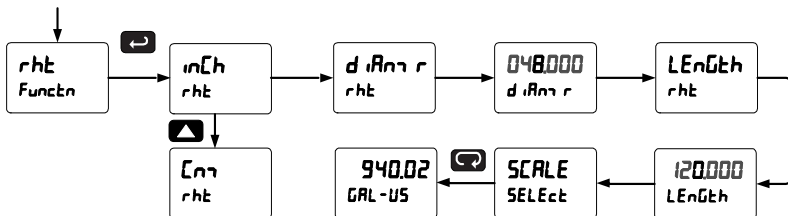

Note: After Scale is displayed continue pressing the Enter button until the meter completes the scaling of the input and display values.

Changing the Volume from Gallons to Liters

In the above graphic, entering the 48" for the diameter and 120" for the length of the round horizontal tank, the meter automatically calculates that the volume of the tank is 940.02 gallons.

1. Convert gallons to liters
 1 US gallon = 3.7854 L
 940.02 gal = 3558.4 L
2. Go to the *Setup* menu and change the decimal point to 1 decimal.
3. Go to the *Program – Scale* menu and press Enter until d ,5 2 is shown on the main display.
4. Press Enter and change the display 2 value to 3558.4.
5. The meter is now displaying the volume in liters.

Note: The display can be scaled to display the volume in any engineering units.

Low-Flow Cutoff (L_ut_oFF)

The low-flow cutoff feature allows the meter to be programmed so that the often-unsteady output from a differential pressure transmitter, at low flow rates, always displays zero on the meter.

The cutoff value may be programmed from 0 to 999999. The meter will display zero below the cutoff value. Programming the cutoff value to zero disables the cutoff feature.

Analog Output Programming (R_ou_tP_r)

The *Analog Output Programming* menu is used to program the behavior of the 4-20 mA output. The following parameters and functions are programmed in this menu:

1. Source: Source for generating the 4-20 mA output (e.g. PV)
2. Overrange: Analog output value with display in overrange condition
3. Underrange: Analog output value with display in underrange condition
4. Break: Analog output value when loop break is detected
5. Max: Maximum analog output value allowed regardless of input
6. Min: Minimum analog output value allowed regardless of input
7. Calibrate: Calibrate the internal 4-20 mA source reference used to scale the 4-20 mA output

Analog Output Source

The source for generating the 4-20 mA output may be assigned to the process variable, maximum or minimum value reached by the process, one of the set points, or the Modbus PV input.

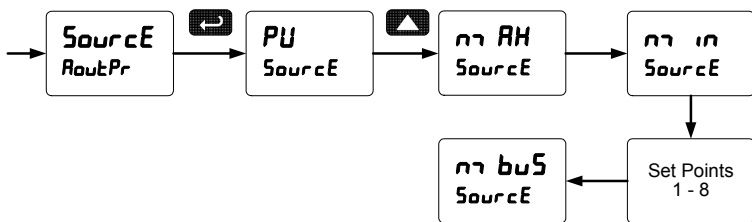

Analog Output Calibration

To perform the analog output calibration it is recommended to use a milliamp meter with a resolution of at least 0.1 μ A to measure the output current. The values saved internally during this procedure are used for scaling the 4-20 mA output in the *Setup* menu.

Programmable Function Keys User Menu (μSEr)

The *User* menu allows the user to assign the front panel function keys F1, F2, F3 and up to eight digital inputs to access most of the menus or to activate functions immediately (e.g. Reset max & min). Up to eight digital outputs can be assigned to a number of actions and functions executed by the meter (e.g. Alarms, relay acknowledgement, etc.).

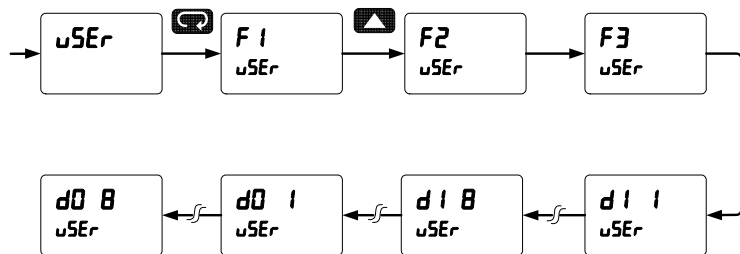

Function Keys & Digital I/O Available Settings

Display	Description	Display	Description
RcH	Acknowledge relays	b μ HL	Max/min big display
rSt Hi	Reset max	L it Hi	Max on little display
rSt Lo	Reset min	L it Lo	Min on little display
rSt HL	Reset max & min	L it HL	Max/min little display
⌈ tArE	Capture tare	d iSRbL	Disable function key
tArESt	Reset tare	n7 Enu	Menu button
rELAY	Relay menu	r μht	Right arrow button/F1
SEt i	Set point 1 - 8	uP	Up arrow button/F2
rLY d	Disable all relays	EnEtEr	Enter button/F3
rLY E	Enable all relays	ALn n i	Alarm 1 – 8
0 HoLd	Relays & output hold	F 0n 1	Force relay 1 on
d HoLd	Display hold	F 0n 2	Force relay 2 on
b μ Hi	Max on big display	F 0n 3	Force relay 3 on
b μ Lo	Min on big display	F 0n 4	Force relay 4 on

Tare (tAr-E)

The tare function zero's out the display. In the case of scale weight, tare is used to eliminate container weight and provide net weight readings. There are two tare functions; Capture Tare and Reset Tare.

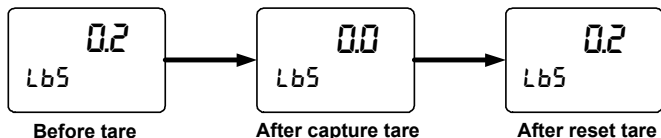

Internal Source Calibration (iCAL)

The meter is factory calibrated prior to shipment to read in milliamps and volts depending on the input selection. The calibration equipment is certified to NIST standards.

The internal source allows the user to scale the meter without applying a signal.

The use of calibrated signal sources is necessary to perform the internal source calibration of the meter.

Check calibration of the meter at least every 12 months. Each input must be recalibrated separately.

Notes:

1. *If meter is in operation and it is intended to accept only one input type (e.g. 4-20 mA), recalibration of other input is not necessary.*
2. *Allow the meter to warm up for at least 15 minutes before performing the internal source calibration procedure.*

The *Internal calibration* menu is part of the *Advanced Features* menu.

1. Press and hold the Menu button for three seconds to access the advanced features of the meter.
2. Press the Up arrow button to scroll to the *Internal calibration* menu (iCAL) and press Enter.

- The meter displays either current calibration (C CAL) or voltage calibration (V CAL), according to the input setup. Press Enter to start the calibration process.

Example of *Internal Calibration* for current input:

- The meter displays *low* input current message (C Lo). Apply the low input signal and press Enter. The display flashes for a moment while the meter is accepting the low input signal.
- After the display stops flashing, a number is displayed with the leftmost digit brighter than the rest. The bright digit is the active digit that can be changed by pressing the Up arrow button. Press the Right arrow button to move to the next digit.
- Set the display value to correspond to the input signal being calibrated, typically 4.000 mA.
- The display moves to the *high* input calibration (C Hi). Apply the high input signal and press Enter.
- Set the display for the high input calibration, in the same way as it was set for the low input calibration, typically 20.000 mA.

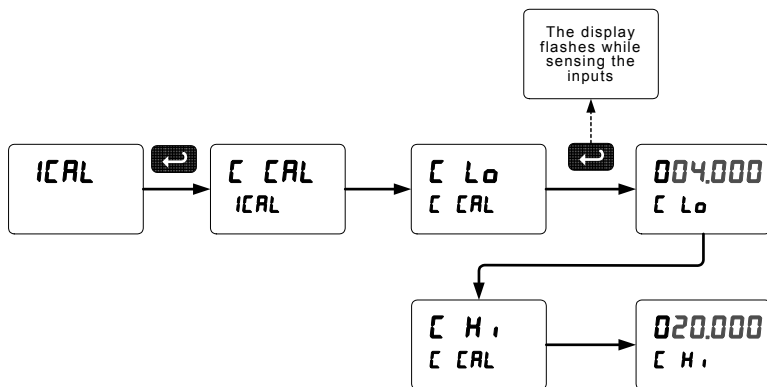

The graphic above shows the calibration of the current input. The voltage input is calibrated in a similar way.

Tips:

- Low and high input signals can be any valid values within the range of the meter.
- Observe minimum input span requirements between input 1 and input 2.
- Low input should be less than high input signal.

Error Message (*Error*)

An error message indicates that the calibration or scaling process was not successful.

After the error message is displayed, the meter reverts to input 2 during calibration or scaling and to input 1 during internal calibration, allowing the appropriate input signal to be applied or programmed.

The error message might be caused by any of the following conditions:

1. Input signal is not connected to the proper terminals, or it is connected backwards.
2. Wrong signal selection in *Setup* menu.
3. Minimum input span requirements not maintained.

Minimum Input Span

The minimum input span is the minimum difference between input 1 and input 2 signals required to complete the calibration or scaling of the meter.

Input Range	Input 1 & Input 2 Span
4-20 mA	0.15 mA
±10 VDC	0.10 VDC

Meter Copy Function (COPY)

The *Copy* function is used to copy (or clone) all the settings from one meter to other meters requiring exactly the same setup and programming (*i.e.* type of input, scaling, decimal point, filter, bypass, etc.).



Warning!

Only the YPPA1200 meter copy cable must be used for meter-to-meter interfacing. The YPPA1200 is a special eight-conductor flat cable with two wires swapped.

Using standard CAT5 or other cable will cause damage to both meters.

YPPA1200 Meter Copy



Figure 19. Meter Copy Connection

Copy Function Requirements

To successfully copy settings from one meter to another, both meters must have:

- 1. Same software version*
- 2. Same baud rate setting*

See Determining Software Version, page 83 for instructions.

Meter Copy or Cloning Instructions



Caution!

Do not connect the two meters to the same signal source while cloning. Internal calibration may be affected.

1. Connect two meters using a YPPA1200 meter copy cable.



Warning!

Using standard CAT5 or other cable will cause damage to both meters. Use YPPA1200 meter copy cable only.

2. Do not connect the two meters to the same signal source.
3. Power up both meters. Leave Clone meter in Run Mode.
4. Enter the *Advanced Features* menu of the Master meter; see *Advanced Features Menu* on page 66.
5. Scroll to the *Copy* function using the Up arrow button then press Enter.
6. The meter displays the message *SEnd*. Press Enter, the display flashes while sending data. The message *donE* is displayed when copying is completed.

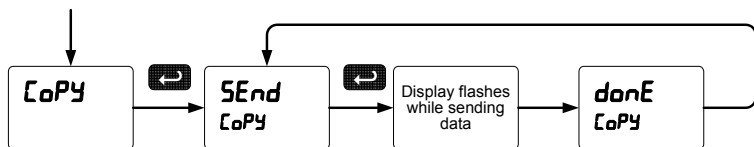

7. The Clone meter displays the message *CPY rE* while being programmed then the message *donE* when copying is completed. The meter initializes and returns to Run Mode using the same settings as the Master.
8. If meter to be cloned does not respond to the data being sent, refer to **Copy Function Requirements** above.

METER OPERATION





The meter is capable of accepting current (0-20 mA, 4-20 mA) and voltage signals (0-5 V, 1-5 V, 0-10 V, ± 10 V) and displaying these signals in engineering units from -99999 to 999999 (e.g. a 4-20 mA signal could be displayed as -50.000 to 50.000).

The dual-line display can be customized by the user to operate in such a way as to satisfy a specific application. Typically the main display is used for the process variable; while the second display is used engineering units, custom legend, or set point indication.

The analog input can be scaled to display the process in two different scales; for example the main display could indicate level in feet and the second display could indicate the volume in gallons.

Additionally the meter can be set up to display the analog input on the main display and the Modbus input on the second display. The relays and analog output can be programmed to operate from the Modbus PV input.

Front Panel Buttons Operation

Button Symbol	Description
	Press to enter or exit Programming Mode, view settings, or exit max/min readings
	Press to reset max/min readings or other parameter/function assigned through the <i>User</i> menu
	Press to display max/min readings or other parameter/function assigned through the <i>User</i> menu
	Press to acknowledge relays or other parameters/function assigned through the <i>User</i> menu

Function Keys Operation

During operation, the programmable function keys operate according to the way they have been programmed in the *Advanced Features – User* menu.

The table above shows the factory default settings for F1, F2, and F3.

Maximum/Minimum Readings

The max & min readings (peak & valley) reached by the process can be displayed either continuously or momentarily:

1. Display briefly by assigning to the F1-F3 function keys or to the digital inputs in the *User* menu.
2. Display continuously by assigning either display to max/min through the *Display* menu.

Any of the F1-F3 function keys (buttons) and the digital inputs can be programmed to reset the max & min readings. The meters are set at the factory to display the max reading by pressing the Up arrow/F2 button and to use the Right arrow/F1 button to access the *Reset* menu.

To display max reading using function key with factory defaults:

1. Press Up arrow/F2 button to display maximum reading since the last reset/power-up.
2. To reset max/min press Right arrow/F1 button to access the Reset menu. The max & min displays are reset to actual values.
3. Press Menu to exit max/min display reading.

To display max/min readings continuously:

Assign either display to Max (d H i), Min (d L o), or toggle between Max and Min (d HL) every 10 seconds.

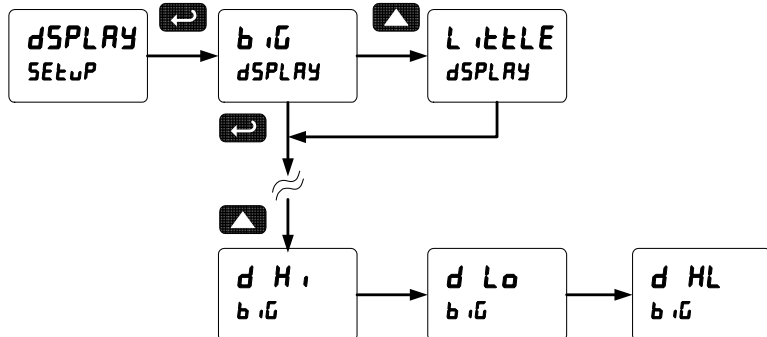

TROUBLESHOOTING

The rugged design and the user-friendly interface of the meter should make it unusual for the installer or operator to refer to this section of the manual. However, due to the many features and functions of the meter, it's possible that the setup of the meter does not agree with what an operator expects to see.

If the meter is not working as expected, refer to the *Diagnostics* menu and recommendations below.

Diagnostics Menu (d iRG)

The *Diagnostics* menu is located in the *Advanced Features* menu, to access *Diagnostics* menu see *Advanced Features Menu*, page 66.

It provides an easy way to view the programmed parameter settings for troubleshooting purposes. Press the Enter button to view the settings and the Menu button to exit at any time.

For a description of the diagnostic messages, see *Advanced Features Menu & Display Messages*, page 67.

Determining Software Version

To determine the software version of a meter:

1. Go to the *Diagnostics* menu (d iRG) and press Enter button.
2. Press Up arrow button and scroll to Information menu (iRFd).
3. Press Enter to access the software number (5Ft) and version (UER) information. Write down the information as it is displayed. Continue pressing Enter until all the information is displayed.
4. The meter returns to Run Mode after displaying all the settings.

Reset Meter to Factory Defaults

When the parameters have been changed in a way that is difficult to determine what's happening, it might be better to start the setup process from the factory defaults.

Instructions to load factory defaults:

1. Enter the *Advanced Features* menu. See *Advanced Features Menu*, page 66.
2. Press Up arrow to go to *Diagnostics* menu
3. Press and hold Right arrow for five seconds, press Enter when display flashes *rESEt*.
Note: If Enter is not pressed within three seconds, the display returns to the *Diagnostics* menu.
4. The meter goes through an initialization sequence (similar as on power-up), and loads the factory default settings.

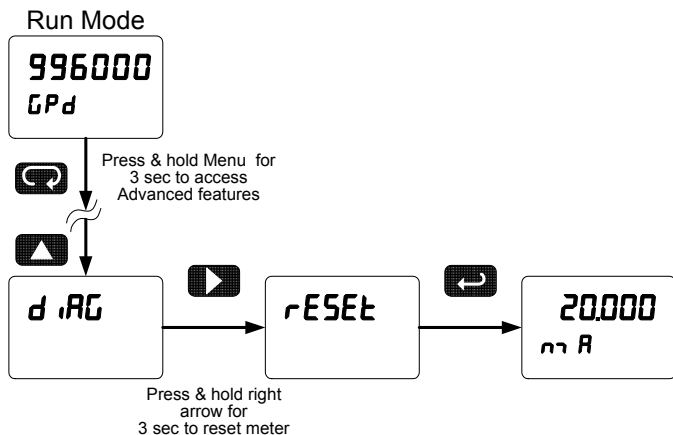

Note: The dual-scale selection for level applications (LEVEL) is not reset to the single scale factory default. This can be changed using the Setup – Input menu.

Factory Defaults & User Settings

The following table shows the factory setting for most of the programmable parameters on the meter. Next to the factory setting, the user may record the new setting for the particular application.

Model: _____ S/N: _____ Date: _____

Parameter	Display	Default Setting	User Setting
Input type	<i>INPuT</i>	4-20 mA	
Level feature	<i>LEVEL</i>	No (Single scale)	
Filter	<i>FILTER</i>	70	
Bypass	<i>BYPASS</i>	0.2	
Function	<i>FUNCTION</i>	Linear	
Number of points	<i>no Pts</i>	2	
Programming	<i>PROG</i>	Scale	
Input 1	<i>INP 1</i>	4.000 mA	
Display 1	<i>DIS 1</i>	4.000	
Input 2	<i>INP 2</i>	20.000 mA	
Display 2	<i>DIS 2</i>	20.000	
Decimal point	<i>dddd</i>	3 places	
Cutoff value	<i>CUTOFF</i>	0.000 (disabled)	
Display assignment	<i>DISPLAY</i>		
Big display (Main)	<i>big</i>	PV: Process variable	
Little display (Small)	<i>little</i>	Eng units: mA	
Display intensity	<i>display</i>	8	
Relay 1 action	<i>Rel 1</i>	Automatic	
Relay 1 set point	<i>SET 1</i>	1.000	
Relay 1 reset point	<i>rSEt 1</i>	0.500	
Relay 2 action	<i>Rel 2</i>	Automatic	
Relay 2 set point	<i>SET 2</i>	2.000	
Relay 2 reset point	<i>rSEt 2</i>	1.500	
Relay 3 action	<i>Rel 3</i>	Automatic	
Relay 3 set point	<i>SET 3</i>	3.000	

Model YPP6000 Analog Input Process Meter **Instruction Manual**

Parameter	Display	Default Setting	User Setting
Relay 3 reset point	<i>rSE 3</i>	2.500	
Relay 4 action	<i>Act 4</i>	Automatic	
Relay 4 set point	<i>SEt 4</i>	4.000	
Relay 4 reset point	<i>rSE 4</i>	3.500	
Fail-safe relay 1	<i>FLS 1</i>	Off	
Fail-safe relay 2	<i>FLS 2</i>	Off	
Fail-safe relay 3	<i>FLS 3</i>	Off	
Fail-safe relay 4	<i>FLS 4</i>	Off	
On delay relay 1	<i>On 1</i>	0.0 sec	
Off delay relay 1	<i>OFF 1</i>	0.0 sec	
On delay relay 2	<i>On 2</i>	0.0 sec	
Off delay relay 2	<i>OFF 2</i>	0.0 sec	
On delay relay 3	<i>On 3</i>	0.0 sec	
Off delay relay 3	<i>OFF 3</i>	0.0 sec	
On delay relay 4	<i>On 4</i>	0.0 sec	
Off delay relay 4	<i>OFF 4</i>	0.0 sec	
Loop break relay 1	<i>Ignore</i>	Ignore	
Loop break relay 2	<i>Ignore</i>	Ignore	
Loop break relay 3	<i>Ignore</i>	Ignore	
Loop break relay 4	<i>Ignore</i>	Ignore	
Display 1 analog out	<i>d iS 1</i>	4.000	
Output 1 value	<i>Out 1</i>	4.000 mA	
Display 2 analog out	<i>d iS 2</i>	20.000	
Output 2 value	<i>Out 2</i>	20.000 mA	
Source analog output	<i>Source</i>	Process Variable	
Overrange output	<i>o-rRH</i>	21.000 mA	
Underrange output	<i>u-rRH</i>	3.000 mA	
Loop break output	<i>brERH</i>	1.000 mA	
Maximum output	<i>rr RH</i>	23.000 mA	

Model YPP6000 Analog Input Process Meter Instruction Manual

Parameter	Display	Default Setting	User Setting
Minimum output	<i>00.00</i>	0.000 mA	
Slave ID (Address)	<i>SLAVE id</i>	247	
Baud rate	<i>baud</i>	9600	
Transmit delay	<i>tr dLY</i>	10 ms	
Parity	<i>PAR itY</i>	Even	
Byte-to-byte timeout	<i>t-bytE</i>	010 (0.1 sec)	
F1 function key	<i>F 1</i>	Reset max & min	
F2 function key	<i>F 2</i>	Big display: Max (Hi)	
F3 function key	<i>F 3</i>	Acknowledge relays	
Digital input 1	<i>d i 1</i>	Menu	
Digital input 2	<i>d i 2</i>	Right arrow	
Digital input 3	<i>d i 3</i>	Up arrow	
Digital input 4	<i>d i 4</i>	Enter	
Digital output 1	<i>dO 1</i>	Alarm 1	
Digital output 2	<i>dO 2</i>	Alarm 2	
Digital output 3	<i>dO 3</i>	Alarm 3	
Digital output 4	<i>dO 4</i>	Alarm 4	
Password 1	<i>PASS 1</i>	000000 (unlocked)	
Password 2	<i>PASS 2</i>	000000 (unlocked)	
Password 3	<i>PASS 3</i>	000000 (unlocked)	

Troubleshooting Tips

Symptom	Check/Action
No display at all	Check power at power connector
Not able to change setup or programming, <i>Locd</i> is displayed	Meter is password-protected, enter correct six-digit password to unlock
Meter displays error message during calibration (<i>Error</i>)	Check: <ol style="list-style-type: none"> Signal connections Input selected in <i>Setup</i> menu Minimum input span requirements
Meter displays <ol style="list-style-type: none"> 999999 -999999 	Check: <ol style="list-style-type: none"> Input selected in <i>Setup</i> menu Corresponding signal at Signal connector
Display is unstable	Check: <ol style="list-style-type: none"> Input signal stability and value Display scaling vs. input signal Filter and bypass values (increase)
Display response is too slow	Check filter and bypass values
Display reading is not accurate	Check: <ol style="list-style-type: none"> Signal input conditioner selected: Linear, square root, etc. Scaling or calibration
Display does not respond to input changes, reading a fixed number	Check: <ol style="list-style-type: none"> Display assignment, it might be displaying max, min, or set point.
Display alternates between <ol style="list-style-type: none"> <i>H i</i> and a number <i>Lo</i> and a number 	Press Menu to exit max/min display readings.
Relay operation is reversed	Check: <ol style="list-style-type: none"> Fail-safe in <i>Setup</i> menu Wiring of relay contacts
Relay and status LED do not respond to signal	Check: <ol style="list-style-type: none"> Relay action in <i>Setup</i> menu Set and reset points
Flashing relay status LEDs	Relays in manual control mode or relay interlock switches opened.
Meter not communicating with application programs	Check: <ol style="list-style-type: none"> Serial adapter and cable Serial settings Meter address and baud rate
If the display locks up or the meter does not respond at all	Cycle the power to reboot the microprocessor.
Other symptoms not described above	Call Technical Support for assistance.

Alphabetical List of Display Functions & Messages

Display	Parameter	Action/Setting Description
20 mA	20 mA output	Enter mA output value read by milliamp meter with at least 0.001 mA resolution
4 mA	4 mA output	Enter mA output value read by milliamp meter with at least 0.001 mA resolution
999999 -999999	Flashing display	Overrange condition Underrange condition
ACK	Acknowledge	Acknowledge relays
ACT 1	Action 1	Set relay 1 action
ALARM 1	Alarm 1	Assign digital output to Alarm 1-8
ALTERNATE	Alternate	Set relay for pump alternation control
AMAN	Auto-manual	Set relay for automatic & manual reset
ANOUT	Analog output	Enter the Analog output scaling menu
ANOUTPR	Analog output programming	Enter analog output programming
AUTO	Automatic	Press Enter to set automatic operation
BAUD	Baud rate	Select baud rate
BIG	Big display	Press Enter to assign the main display parameter (default: PV)
BIG MAX	Max on big display	Assign digital input to display max on the main display
BIG MAX/MIN	Max/min big display	Assign digital input to toggle max/min on the main display
BIG MIN	Min on big display	Assign digital input to display min on the main display
BRK	Loop break	Set relay condition if loop break detected
BYPASS	Bypass	Set filter bypass value
CAL	Current calibration	Calibrate 4-20 mA current input (internal reference source used for scaling the input)
CAL HIGH	Current high	Calibrate high current input (e.g. 20 mA)
CAL LOW	Current low	Calibrate low current input (e.g. 4 mA)
CAPTURE	Capture tare	Capture tare

Model YPP6000 Analog Input Process Meter Instruction Manual

Display	Parameter	Action/Setting Description
CL	Calibrate	Enter the <i>Calibration</i> menu
CLib	Calibrate	Calibrate 4-20 mA output (internal reference source used for scaling the output)
Control	Control	Enter <i>Control</i> menu to turn relays on/off, set analog output manually, or return meter to automatic operation
COPY	Copy	Enter copy function
Cutoff	Cutoff	Set low-flow cutoff
dHi	Display high	Select to display the max
dHL	Display H&L	Select to display the max & min toggling
dHold	Display hold	Display hold
dLo	Display low	Select to display the min
dPCT	Display PCT	Select to display percent of PV1 (dual-scale display)
dPV	Display PV	Select to display PV
dPV1	Display PV1	Select to display PV1 (dual-scale display)
dPV2	Display PV2	Select to display PV2 (dual-scale display)
d r-u	Display r-u	Select to display reading and units
d units	Display units	Select to display engineering units or label
dECPt	Decimal point	Set decimal point
dELAY	Delay	Enter relay <i>Time Delay</i> menu
d i 1	Digital input 1	Assign digital input 1-8, if expansion modules are connected
d,RC	Diagnostics	Display parameter settings
d,RR r	Diameter	Enter the tank's diameter in inches
d-intY	Display intensity	Set display intensity level from 1 to 8
dS 1	Display 1	Program display 1 value
dS 2	Display 2	Program display 2 value (up to 32 points)
d,SRbL	Disable	Disable function key
dLY 1	Delay 1	Enter relay 1 time delay setup (1-8)

Display	Parameter	Action/Setting Description
<i>dO 1</i>	<i>Digital output 1</i>	Assign digital output 1 – 8, if expansion modules are connected
<i>done</i>	<i>Done</i>	Copy function completed
<i>dSEt 1</i>	<i>Display set 1</i>	Select to display set point 1 (1-8)
<i>dSPRAY</i>	<i>Display</i>	Enter the <i>Display</i> menu
<i>EntEr</i>	<i>Enter button</i>	Assign digital input to Enter button/F3
<i>Error</i>	<i>Error</i>	Error, calibration not successful, check signal or programmed value
<i>F On 1</i>	<i>Force On 1</i>	Force relay 1 on using digital input (1-4)
<i>F 1</i>	<i>F1 function key</i>	Assign F1 function key
<i>F2</i>	<i>F2 function key</i>	Assign F2 function key
<i>F3</i>	<i>F3 function key</i>	Assign F3 function key
<i>FR iLSF</i>	<i>Fail-safe</i>	Enter <i>Fail-safe</i> menu
<i>F iLEr</i>	<i>Filter</i>	Set noise filter value
<i>FLS 1</i>	<i>Fail-safe 1</i>	Set relay 1 fail-safe operation (1-8)
<i>ForcE</i>	<i>Force</i>	Force analog output value for loop break
<i>FuncE n</i>	<i>Signal input conditioner</i>	Select linear, square root, programmable exponent, or round horizontal tank function
<i>iCRl</i>	<i>Internal source calibration</i>	Enter internal source calibration (used for scaling the meter without a signal source)
<i>iGnorE</i>	<i>Ignore</i>	Ignore loop break condition
<i>inFo</i>	<i>Information</i>	Display software and S/N information
<i>inP 1</i>	<i>Input 1</i>	Calibrate input 1 signal or program input 1 value
<i>inP 2</i>	<i>Input 2</i>	Calibrate input 2 signal or program input 2 value (up to 32 points)
<i>inP uE</i>	<i>Input</i>	Enter <i>Input</i> selection menu
<i>LrLECH</i>	<i>Latching</i>	Set relay for latching operation
<i>LEd t</i>	<i>LED test</i>	Test all LEDs

Display	Parameter	Action/Setting Description
LEnGtH	<i>Length</i>	Enter the tank's length in inches
LEUEL	<i>Level</i>	Enter <i>Level</i> menu and select <i>Yes</i> for dual-scale display or <i>No</i> for single scale display
LinERr	<i>Linear</i>	Set meter for linear function and select number of linearization points
Max H i	Max on little display	Assign digital input to display max on the small display
Max HL	Max/min little display	Assign digital input to toggle max/min on the small display
Min Lo	Min on little display	Assign digital input to display min on the small display
Little LE	<i>Little display</i>	Press Enter to assign the small display parameter (default: engineering units)
Locd	<i>Locked</i>	Enter password to unlock meter
Latching-cleared	<i>Latching-cleared</i>	Set relay for latching operation with manual reset only after alarm condition has cleared
4-20 mA	<i>4-20 mA</i>	Set meter for 4-20 mA input
Manual	<i>Manual</i>	Press Enter to manually control relays or analog output operation
Maximum	<i>Maximum</i>	Program maximum mA output allowed
Modbus	<i>Modbus</i>	Select to display Modbus input or to assign Modbus input as the analog output source
Menu button	<i>Menu button</i>	Assign digital input to Menu button
Minimum	<i>Minimum</i>	Program minimum mA output allowed
Number of points	<i>Number of points</i>	Set meter for 2 to 32-point linearization
Relays output hold	<i>Relays output hold</i>	Assign digital input to hold all relays state hold
Off	<i>Off</i>	Disable relay and front panel status LED, turn relays off, program off time delay
Off 1	<i>Off 1</i>	Set relay 1 Off time delay (1-8)
On	<i>On</i>	Enable fail-safe operation, turn relays on, program on time delay
On 1	<i>On 1</i>	Set relay 1 On time delay (1-8)

Model YPP6000 Analog Input Process Meter Instruction Manual

Display	Parameter	Action/Setting Description
<i>0-rRnG</i>	<i>Overrange</i>	Program mA output for display overrange
<i>Out 1</i>	<i>Output 1</i>	Program output 1 value (e.g. 4.000 mA)
<i>Out 2</i>	<i>Output 2</i>	Program output 2 value (e.g. 20.000 mA)
<i>PASS</i>	<i>Password</i>	Enter the <i>Password</i> menu
<i>PASS 1</i>	<i>Password 1</i>	Set or enter Password 1 (Allows use of the F1–F3 function keys)
<i>PASS 2</i>	<i>Password 2</i>	Set or enter Password 2 (Allows use of the F1–F3 function keys and changing the set/reset points)
<i>PASS 3</i>	<i>Password 3</i>	Set or enter Password 3 (Restricts all programming & F1–F3 keys)
<i>Prog</i>	<i>Program</i>	Enter the <i>Program</i> menu
<i>Prog E</i>	<i>Programmable exponent</i>	Set meter for programmable exponent and enter exponent value
<i>RELAY</i>	<i>Relay</i>	Enter the <i>Relay</i> menu
<i>RESET</i>	<i>Reset</i>	Press Enter to access the <i>Reset</i> menu
<i>rhL</i>	<i>Round horizontal tank</i>	Set meter for round horizontal tank volume calculation
<i>r →hL</i>	<i>Right arrow</i>	Assign digital input to Right arrow button/F1
<i>RLY 1</i>	<i>Relay 1</i>	Relay 1 setup (1-8)
<i>RLY d</i>	<i>Disable relay</i>	Assign digital input to disable all relays
<i>RLY E</i>	<i>Enable relay</i>	Assign digital input to enable all relays
<i>rSt 1</i>	<i>Reset 1</i>	Program reset point 1 (1-8)
<i>rSt H 1</i>	<i>Reset high</i>	Press Enter to reset max display
<i>rSt HL</i>	<i>Reset high & low</i>	Press Enter to reset max & min displays
<i>rSt Lo</i>	<i>Reset low</i>	Press Enter to reset min display
<i>SRn PL</i>	<i>Sampling</i>	Set relay for sampling operation
<i>SCALE 1</i>	<i>Scale 1</i>	Enter the <i>Scale 1</i> menu for PV1
<i>SCALE 2</i>	<i>Scale 2</i>	Enter the <i>Scale 2</i> menu for PV2
<i>SCALE</i>	<i>Scale</i>	Enter the <i>Scale</i> menu

Display	Parameter	Action/Setting Description
<i>SELEct</i>	<i>Select</i>	Enter Select menu (function, cutoff, output programming)
<i>SEnd</i>	<i>Send</i>	Send meter settings to another meter
<i>SErIAL</i>	<i>Serial</i>	Set serial communication parameters
<i>SEt 1</i>	<i>Set 1</i>	Program set point 1 (1-8)
<i>SEtUP</i>	<i>Setup</i>	Enter <i>Setup</i> menu
<i>SLAVE id</i>	<i>Slave ID</i>	Set Slave ID or meter address
<i>Source</i>	<i>Source</i>	Select source for the 4-20 mA output
<i>SqURrE</i>	<i>Square root</i>	Set meter for square root extraction
<i>TARESt</i>	<i>Reset tare</i>	Reset tare
<i>Tr dLY</i>	<i>Transmit delay</i>	Set transmit delay for serial communication
<i>unLoc</i>	<i>Unlocked</i>	Program password to lock meter
<i>uP</i>	<i>Up arrow</i>	Assign digital input to Up arrow button/F2
<i>u-rRNG</i>	<i>Underrange</i>	Program mA output for display underrange
<i>uSEr</i>	<i>User I/O</i>	Assign function keys and digital I/O
<i>U CAL</i>	<i>Voltage calibration</i>	Calibrate voltage input
<i>U Hi</i>	<i>Voltage high</i>	Calibrate high voltage input (e.g. 10 V)
<i>U Lo</i>	<i>Voltage low</i>	Calibrate low voltage input (e.g. 0 V)
<i>UoLEt</i>	<i>0-10 VDC</i>	Set meter for ± 10 VDC input

DIMENSIONS

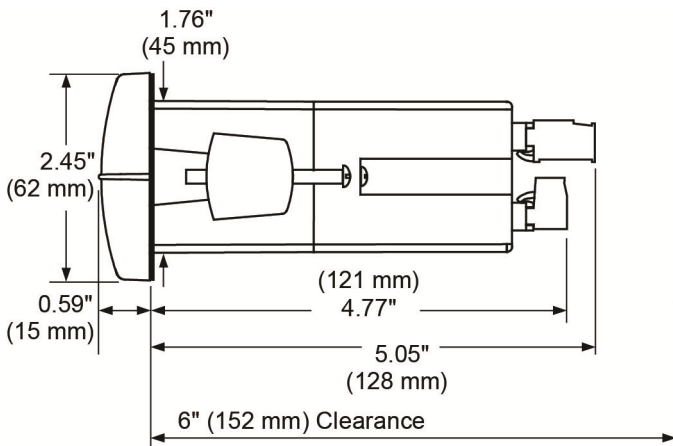

Figure 20. Meter Dimensions - Side View

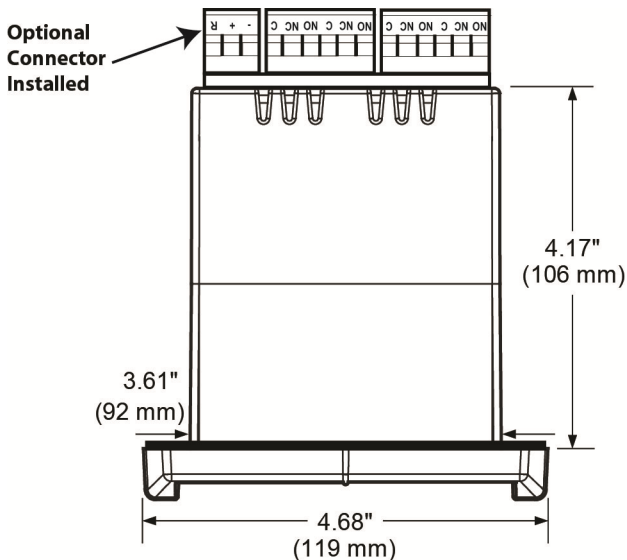

Figure 21. Meter Dimensions - Top View

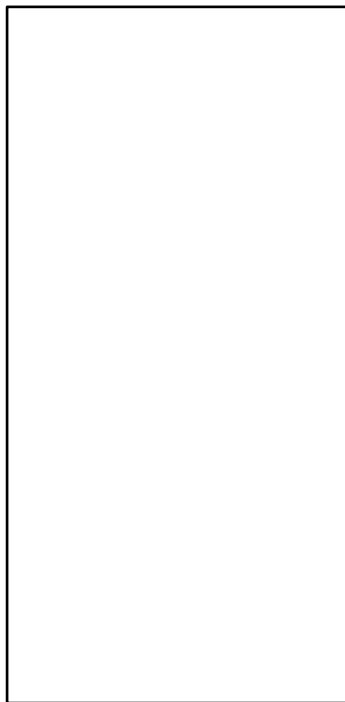

Figure 22. 1/8 DIN Panel Cutout Template

How to Contact Yokogawa Corporation of America

- For Sales and Technical Support please
Call: (800) 888-6400 or (770) 254-0400
Fax: (770) 251-2088
Email: meters-instr@us.yokogawa.com
- For the latest version of this manual please visit
www.yokogawa-usa.com