**User's
Manual**

**Model RAGN
Glass ROTAMETER**

IM 01R01B10-00E-E

vigilantplant.™

Contents

1. Introduction	1-1
1.1 ATEX Documentation.....	1-3
1.2 General description.....	1-4
1.3 Principle of measurement	1-4
1.4 Intended use	1-4
2. Transportation and Storage	2-1
3. Product description	3-1
3.1 Metering Tube	3-1
3.2 Bistable inductive ring sensor (Option /GR2 to /GR8)	3-2
3.3 Magnetic contact (Option /GM1 to /GM5).....	3-2
3.4 Marking	3-3
4. Installation	4-1
4.1 General.....	4-1
4.2 Piping.....	4-2
4.3 Bistable inductive ring sensor (Option /GR2 to /GR8)	4-3
4.4 Magnetic contact (Option /GM1 to /GM5).....	4-4
4.5 Connection box (Option /GD1 or /GD2).....	4-5
5. Service	5-1
5.1 Customer maintenance part list (CMPL).....	5-1
5.2 Template for sending back to service	5-4
6. Explosion protected type instruments	6-1
6.1 Bistable inductive ring sensor (Option /GR2 to /GR8)	6-1
6.2 Magnetic contact (Option /GM1 to /GM5).....	6-3
7. Instructions for PED	7-1
8. Technical Data	8-1

APPENDIX 1. Safety Instrumented Systems Installation.....	A1-1
A1.1 Scope and Purpose	A1-1
A1.2 Using RAGN for a SIS Application.....	A1-1
A1.2.1 Safety Function.....	A1-1
A1.2.2 Diagnostic Response Time	A1-2
A1.2.3 Setup	A1-2
A1.2.4 Proof Testing	A1-2
A1.2.5 Repair and replacement.....	A1-2
A1.2.6 Startup Time	A1-3
A1.2.7 Reliability data	A1-3
A1.2.8 Lifetime limits	A1-3
A1.2.9 Environmental limits.....	A1-3
A1.2.10 Application limits	A1-3
A1.3 Definitions and Abbreviations	A1-4
A1.3.1 Definitions	A1-4
A1.3.2 Abbreviations	A1-4
A1.4 Assessment results	A1-4
A1.4.1 Safety related parameters.....	A1-4

1. Introduction

Before use, read this manual thoroughly and familiarize yourself fully with the features, operations and handling of Rotameter RAGN to have the instrument deliver its full capabilities and to ensure its efficient and correct use.

Notices Regarding This Manual

- This manual should be passed to the end user.
- The contents of this manual are subject to change without prior notice.
- All rights reserved. No part of this document may be reproduced or transmitted in any form or by any means without the written permission of Rota Yokogawa (hereinafter simply referred to as Yokogawa).
- This manual neither does warrant the marketability of this instrument nor it does warrant that the instrument will suit a particular purpose of the user.
- Every effort has been made to ensure accuracy in the contents of this manual. However, should any questions arise or errors come to your attention, please contact your nearest Yokogawa sales office that appears on the back of this manual or the sales representative from which you purchased the product.
- This manual is not intended for models with custom specifications.
- Revisions may not always be made in this manual in conjunction with changes in specifications, constructions and/or components if such changes are not deemed to interfere with the instrument's functionality or performance.

Notices Regarding Safety and Modification

- For the protection and safety of personnel, the instrument and the system comprising the instrument, be sure to follow the instructions on safety described in this manual when handling the product. If you handle the instrument in a manner contrary to these instructions, Yokogawa does not guarantee safety.
- If this instrument is used in a manner not specified in this manual, the protection provided by this instrument may be impaired.
- As for explosion proof model, if you yourself repair or modify the instrument and then fail to return it to its original form, the explosion protected construction of the instrument will be impaired, creating a hazardous condition. Be sure to consult Yokogawa for repairs and modifications.

The following safety symbols and cautionary notes are used on the product and in this manual:



WARNING

This symbol is used to indicate that a hazardous condition will result which, if not avoided, may lead to loss of life or serious injury. This manual describes how the operator should exercise care to avoid such a risk..



CAUTION

This symbol is used to indicate that a hazardous condition will result which, if not avoided, may lead to minor injury or material damage. This manual describes how the operator should exercise care to avoid a risk of bodily injury or damage to the instrument.



IMPORTANT

This symbol is used to call your attention to a condition that must be observed in order to avoid the risk of damage to the instrument or system problems.



NOTE

This symbol is used to call your attention to information that should be referred to in order to know the operations and functions of the instrument.

For Safe Use of Rotameter RAGN



WARNING

- If the process fluid is harmful to personnel, handle Rotameter RAGN carefully even after it has been removed from the process line for maintenance or other purposes. Exercise extreme care to prevent the fluid from coming into contact with human flesh and to avoid inhaling any residual gas.
- In case of Explosion proof type instrument, further requirements and differences are described in Chapter 6 "EXPLOSION PROTECTED TYPE INSTRUMENTS". The description in Chapter 6 is prior to other descriptions in this instruction manual.

Warranty

- The warranty of this instrument shall cover the period noted on the quotation presented to the Purchaser at the time of purchase. The Seller shall repair the instrument free of charge when the failure occurred during the warranty period.
- All inquiries on instrument failure should be directed to the Seller's sales representative from whom you purchased the instrument or your nearest sales office of the Seller.
- Should the instrument fail, contact the Seller specifying the model and instrument number of the product in question. Be specific in describing details on the failure and the process in which the failure occurred. It will be helpful if schematic diagrams and/or records of data are attached to the failed instrument.
- Whether or not the failed instrument should be repaired free of charge shall be left solely to the discretion of the Seller as a result of an inspection by the Seller.

The Purchaser shall not be entitled to receive repair services from the Seller free of charge, even during the warranty period, if the malfunction or damage is due to:

- improper and/or inadequate maintenance of the instrument in question by the Purchaser.
- handling, use or storage of the instrument in question beyond the design and/or specifications requirements.
- use of the instrument in question in a location not conforming to the conditions specified in the Seller's General Specification or Instruction Manual.
- retrofitting and/or repair by an other party than the Seller or a party to whom the Seller has entrusted repair services.
- improper relocation of the instrument in question after delivery.
- reason of force measure such as fires, earthquakes, storms/ floods, thunder/lightning, or other reasons not attributable to the instrument in question.
- YOKOGAWA gives no warranty for the improper use of glass flow meters. Due to the uncontrollably of the material YOKOGAWA cannot guarantee that the material is fracture-proof.

**WARNING**

- When removing the instrument from hazardous processes, avoid contact with the fluid and the interior of the meter.
- In case of Explosion proof type instrument, further requirements and differences are described in Chapter 6 "EXPLOSION PROTECTED TYPE INSTRUMENTS". The description in Chapter 6 is prior to other descriptions in this instruction manual.

Notices regarding EMC

The Rotameter RAGN with option /GR2 ... /GR8 is conform to the European EMC Guideline and fulfills the following standards:

DIN EN 61000-4-2 : level 3

DIN EN 61000-4-3 : level 2

DIN EN 61000-4-4 : level 3

DIN EN 61000-4-6 : level 2

DIN EN 55011 : group 1 / class A

The RAGN with option /GR2 ... /GR8 is a class A product and should be used and installed properly according to the EMC Class A requirements.

**IMPORTANT**

Although the inductive ring sensor has been designed to resist high frequency electrical noise, if a radio transceiver is used near the transmitter or its external wiring, the transmitter may be affected by high frequency noise pickup. To test for such effects, bring the transceiver in use slowly from a distance of several meters from the transmitter, and observe the measurement loop for noise effects. Thereafter, always use the transceiver outside the area affected by noise.

1.1 ATEX Documentation

This is only applicable to the countries in European Union.

- GB** All instruction manuals for ATEX Ex related products are available in English, German and French. Should you require Ex related instructions in your local language, you are to contact your nearest Yokogawa office or representative.
- DK** Alle brugervejledninger for produkter relateret til ATEX Ex er tilgængelige på engelsk, tysk og fransk. Skulle De ønske yderligere oplysninger om håndtering af Ex produkter på eget sprog, kan De rette henvendelse herom til den nærmeste Yokogawa afdeling eller forhandler.
- I** Tutti i manuali operativi di prodotti ATEX contrassegnati con Ex sono disponibili in inglese, tedesco e francese. Se si desidera ricevere i manuali operativi di prodotti Ex in lingua locale, mettersi in contatto con l'ufficio Yokogawa più vicino o con un rappresentante.
- E** Todos los manuales de instrucciones para los productos antiexplosivos de ATEX están disponibles en inglés, alemán y francés. Si desea solicitar las instrucciones de estos artículos antiexplosivos en su idioma local, deberá ponerse en contacto con la oficina o el representante de Yokogawa más cercano.
- NL** Alle handleidingen voor producten die te maken hebben met ATEX explosiebeveiliging (Ex) zijn verkrijgbaar in het Engels, Duits en Frans. Neem, indien u aanwijzingen op het gebied van explosiebeveiliging nodig hebt in uw eigen taal, contact op met de dichtstbijzijnde vestiging van Yokogawa of met een vertegenwoordiger.
- SF** Kaikkien ATEX Ex -tyyppisten tuotteiden käyttöohjeet ovat saatavilla englannin-, saksan- ja ranskan kielisinä. Mikäli tarvitsette Ex -tyyppisten tuotteiden ohjeita omalla paikallisella kielellänne, ottakaa yhteyttä lähimpään Yokogawa-toimistoon tai -edustajaan.
- P** Todos os manuais de instruções referentes aos produtos Ex da ATEX estão disponíveis em Inglês, Alemão e Francês. Se necessitar de instruções na sua língua relacionadas com produtos Ex, deverá entrar em contacto com a delegação mais próxima ou com um representante da Yokogawa.
- F** Tous les manuels d'instruction des produits ATEX Ex sont disponibles en langue anglaise, allemande et française. Si vous nécessitez des instructions relatives aux produits Ex dans votre langue, veuillez bien contacter votre représentant Yokogawa le plus proche.
- D** Alle Betriebsanleitungen für ATEX Ex bezogene Produkte stehen in den Sprachen Englisch, Deutsch und Französisch zur Verfügung. Sollten Sie die Betriebsanleitungen für Ex-Produkte in Ihrer Landessprache benötigen, setzen Sie sich bitte mit Ihrem örtlichen Yokogawa-Vertreter in Verbindung.
- S** Alla instruktionsböcker för ATEX Ex (explosionssäkra) produkter är tillgängliga på engelska, tyska och franska. Om Ni behöver instruktioner för dessa explosionssäkra produkter på annat språk, skall Ni kontakta närmaste Yokogawakontor eller representant.
- GR** Όλα τα εγχειρίδια λειτουργίας των προϊόντων με ATEX Ex διατίθενται στα Αγγλικά, Γερμανικά και Γαλλικά. Σε περίπτωση που χρειάζεστε οδηγίες σχετικά με Ex στην τοπική γλώσσα παρακαλούμε επικοινωνήστε με το πλησιέστερο γραφείο της Yokogawa ή αντιπρόσωπο της.
- SK** Všetky návody na obsluhu pre prístroje s ATEX Ex sú k dispozícii v jazyku anglickom, nemeckom a francúzskom. V prípade potreby návodu pre Ex-prístroje vo Vašom národnom jazyku, skontaktujte prosím miestnu kanceláriu firmy Yokogawa.
- CZ** Všechny uživatelské příručky pro výrobky, na něž se vztahuje nevybušné schválení ATEX Ex, jsou dostupné v angličtině, němčině a francouzštině. Požadujete-li pokyny týkající se výrobků s nevybušným schválením ve vašem lokálním jazyku, kontaktujte prosím vaši nejbližší reprezentační kancelář Yokogawa.
- LT** Visos gaminių ATEX Ex kategorijos Eksploatavimo instrukcijos teikiami anglų, vokiečių ir prancūzų kalbomis. Norėdami gauti prietaisų Ex dokumentaciją kitomis kalbomis susisiekite su artimiausiu bendrovės "Yokogawa" biuru arba atstovu.
- LV** Visas ATEX Ex kategorijas izstrādājumu Lietošanas instrukcijas tiek piegādātas angļu, vācu un franču valodās. Ja vēlaties saņemt Ex ierīšu dokumentāciju citā valodā, Jums ir jāsazinās ar firmas Jokogava (Yokogawa) tuvāko ofisu vai pārstāvi.
- EST** Kõik ATEX Ex toodete kasutamishendid on esitatud inglise, saksa ja prantsuse keeles. Ex seadmete muukeelse dokumentatsiooni saamiseks pöörduge lähima lokagava (Yokogawa) kontori või esindaja poole.
- PL** Wszystkie instrukcje obsługi dla urządzeń w wykonaniu przeciwwybuchowym Ex, zgodnych z wymaganiami ATEX, dostępne są w języku angielskim, niemieckim i francuskim. Jeżeli wymagana jest instrukcja obsługi w Państwa lokalnym języku, prosimy o kontakt z najbliższym biurem Yokogawy.
- SLO** Vsi predpisi in navodila za ATEX Ex sorodni pridelki so pri roki v angleščini, nemščini ter francoščini. Če so Ex sorodna navodila potrebna v vašem tukejnem jeziku, kontaktirajte vaš najbliži Yokogawa office ili predstavnika.
- H** Az ATEX Ex műszerek gépkönyveit angol, német és francia nyelven adjuk ki. Amennyiben helyi nyelven kérjük az Ex eszközök leírásait, kérjük keressék fel a legközelebbi Yokogawa irodát, vagy képviselőt.
- BG** Всички упътвания за продукти от серията ATEX Ex се предлагат на английски, немски и френски език. Ако се нуждаете от упътвания за продукти от серията Ex на родния ви език, се свържете с най-близкия офис или представителство на фирма Yokogawa.
- RO** Toate manualele de instructiuni pentru produsele ATEX Ex sunt in limba engleza, germana si franceza. In cazul in care doriti instructiunile in limba locala, trebuie sa contactati cel mai apropiat birou sau reprezentant Yokogawa.
- M** Il-manwali kollha ta' l-istruzzjonijiet ghal prodotti marbuta ma' ATEX Ex huma disponibbli bi-Ingliż, bi-Germaniż u bi-Franċiż. Jekk tkun teħtieġ struzzjonijiet marbuta ma' Ex fil-lingwa lokali tiegħek, għandek tikkuntattja lill-egreb rappreżentant jew ufficiċju ta' Yokogawa.

1.2 General description

This manual describes installation, operation and maintenance of the RAGN. Please read it carefully before using this device.

Further, please note that customer features are not described in this manual. When modifying specifications, construction or parts, this manual is not necessarily revised unless it can be assumed that these changes will impair RAGN functions or performance.

All units are thoroughly tested before shipping. Please check the received units visually to ensure that they have not been damaged during transport. In case of defects or questions please contact your nearest YOKOGAWA service centre or sales office. Please describe any defect precisely and indicate model code as well as serial number.

YOKOGAWA refuses any liability for units which have been repaired by the user without prior consent and do not meet the specifications as a consequence.

1.3 Principle of measurement

A Rotameter measures the flow of liquids, gases and steam by using a float inside a conical tube.

The gap between the tube and float is larger at the top to allow a greater flow to pass through the meter. As gravity works in a vertical orientation so the tube needs to be vertically oriented.

Rota Yokogawa developed the free rotating float which stabilises its position in the centre of the cone to provide a more stable flow measurement.

The medium passes through the metering tube from bottom to top and consequently rises the float until there is an annular gap between the inside surface of the metering tube and the float and equilibrium of the following forces has been achieved.

Buoyancy / Gravity / Friction force

The Rotameter principle is one of the oldest and mature principles in flow measurement. This mechanical principle is as simple as it is reliable. The flow is indicated by the top of the float and can be read from the standard scale on the metering tube. The RAGN can be equipped with limit switches option /GR2 to /GR8 and /GM1 to /GM5.

All units are calibrated with water or air by the manufacturer. By adjusting the calibration values to the measured substance's state of aggregation (density, viscosity), the flow rate scale for each measuring tube can be determined.

When the process conditions have changed the scale is not accurate any longer and the glass tube needs to be replaced.

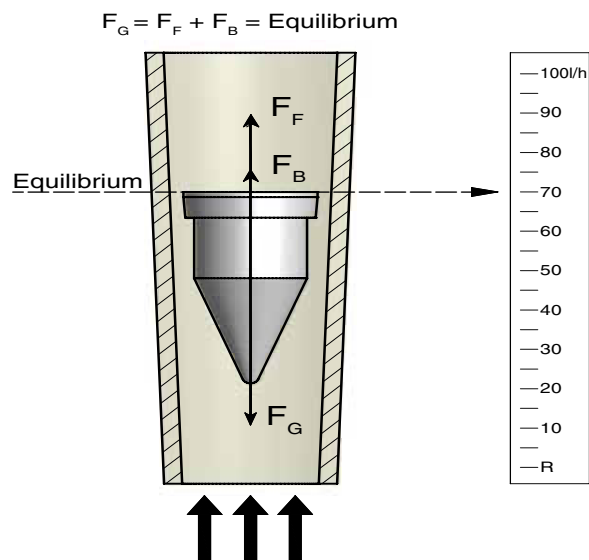

1.4 Intended use

The RAGN is designed for the continuous flow measurement of liquids or gases and can be used in all industries.

Typical applications are:

- Visual fluid monitoring
- Industrial gas measurement
- Controlling of water circuits

2. Transportation and Storage

Transportation instructions

When transporting the instrument, you must observe the following safety instructions in order to avoid lethal injury, damage to the instrument and other material damage.

The steps involved in transport may only be carried out by qualified persons taking into account the safety instructions.

- Observe the transport instructions on the packaging.
- Observe the below mentioned storage conditions.
- Use only the original packaging.
- The packaging material must be disposed of in accordance with the regulations.
- The transport braces must not be removed until installation.
- Read the chapter "Safety instructions".
- To avoid any damages, unpack the flow meter only at the installation site.
- Mechanical shocks are to be avoided.

Storage conditions

Please note the following for storage purposes :

- The instrument should be stored in its transport packaging.
- Choose a storage place that meets the following requirements:
 - Protection from rain and humidity
 - Free of mechanical vibration and shocks
 - Ambient temperature between -25°C to 60°C
 - Atmospheric humidity ranging from 0 to 100%. Operation above 95% for longer times is not recommended

Before storing a used flow meter remove any fluid from the flow meter and clean it in order to avoid fouling.

Properties of the instrument can change when stored outdoors.

Blank Page

3. Product description

3.1 Metering Tube

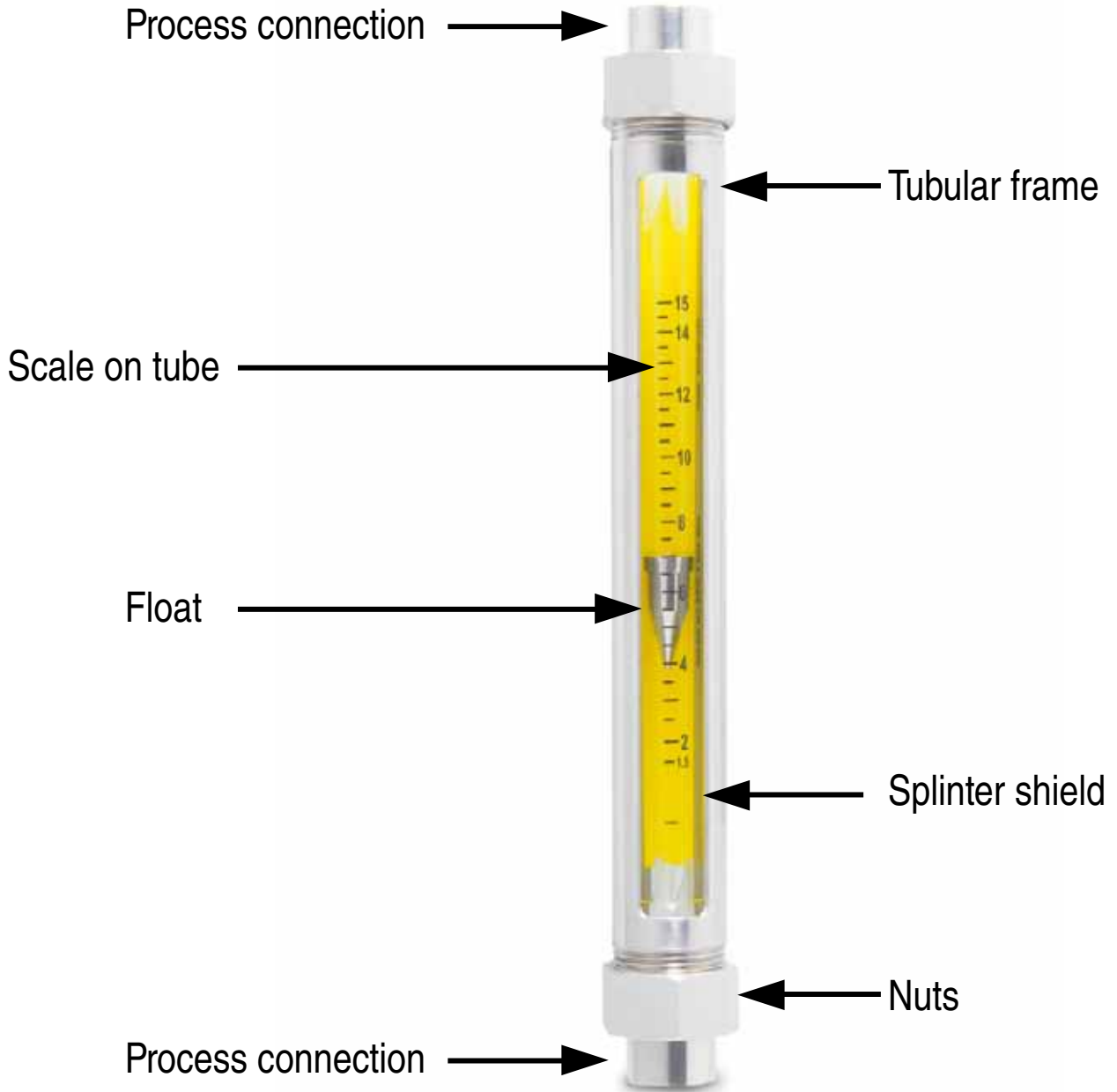

3.2 Bistable inductive ring sensor (Option /GR2 to /GR8)

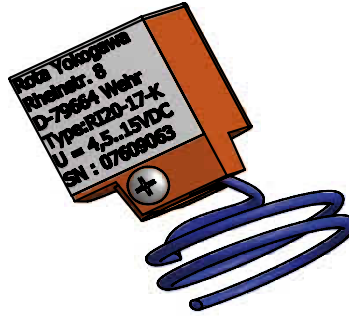

The ring sensor type RI20 is intended for connection to glass Rotameters. It indicates whether the float is positioned above or below the sensor.

The float must have ferromagnetic properties (e.g. a PVDF float with iron core).

The device is offered into 3 versions:

Type	Option	Diameter of tube	Possible float (Yokogawa Code)
RI20-10 G	/GR2, /GR6	10mm	-PD B_N
RI20-17 K	/GR3, /GR7	17mm	-PD C_N
RI20-17 G	/GR4, /GR8	17mm	-PD D_N

The RI20 is bistable, i.e. if the float is below the switch point, current consumption is always < 1 mA and it is > 2.2 mA, if the float is above the switch point. After power on or after power fail the RI20 shows I < 1 mA. To find the correct float position the float has to move once through the RI20.

It is intended for connection to a non-bistable isolation-switch amplifier complying with DIN EN 50227 (NAMUR) (e.g. options /Wxx). With its plastic housing and its sealed-in electronic equipment, the RI20 meets the requirements for protection class IP67 and can also be operated safely in aggressive atmospheres.

The RI20 is maintenance-free.

See chapter 6 "EXPLOSION PROTECTED TYPE INSTRUMENTS" for devices in ATEX version.

3.3 Magnetic contact (Option /GM1 to /GM5)

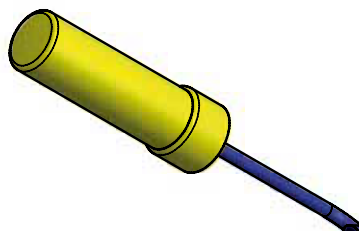

The limit switch is mounted to a Rotameter type RAGN, if a magnetic float is used and indicates if the flow falls below the set limit (MIN-contact) or exceeds the set limit (MAX-contact).

When reaching the switch point the Reed contact with bias by a permanent magnet opens when the float enters the alarm range. The Reed contact closes when the float leaves the alarm range. Opened or closed the Reed contact remains because of its bistability in its position no matter how far the float moves away. Due to the low switch output of the Reed contact (max, 10 VA(W), max. 0.5 A, max. 230 V AC) a transformer isolated barrier (e.g. option /Wxx) should be connected to the GM.

3.4 Marking

Name plate of RAGN:

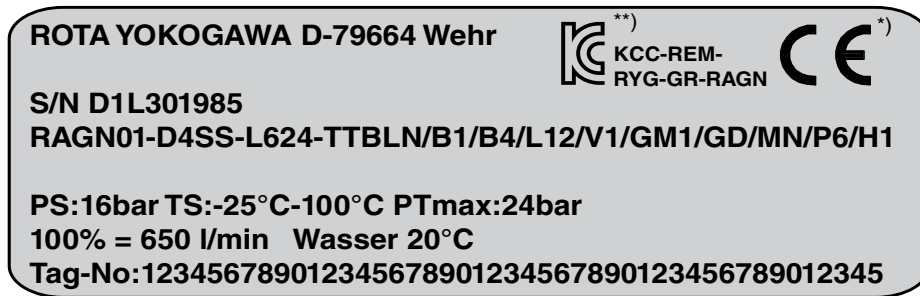

*) only for RAGN04, RAGN05, RAGN06

**) only with option /KC

Name plate of inductive ring sensor (option /GR2 to /GR8)

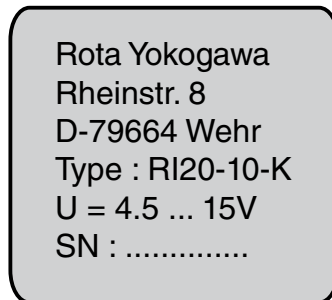

Blank Page

4. Installation

4.1 General

Installation:

All packaging material must be removed. The transportation lock for the float must be removed.

The piping shall be flushed before installing the flowmeter. Piping must be dried for gas applications. Rotameters must be installed vertically. The flow direction is from bottom to top. Prevent the device from mechanical stress and vibration by aligning and supporting the piping. Avoid large volumes of gas downstream and upstream of the device, this can cause vibration due to compression. Install the On/Off valve downstream in order to avoid

damage when opening the valve. In case of gas applications, increase the flow pressure slowly. Avoid pressure surges and temperature shocks to the flowmeter at any time.

Refer to the pressure and temperature limits of the device. For flowmeters with limit switches please see chapter 4.3, 4.4 and 4.5.

Further installation hints can be found in VDI/VDE 3513 sheet 3.

Commissioning:

When functioning properly, the float moves freely in the flow. With floats with notches this can be easily seen by their rotation. If the float does not move, please check the installation.

The flow rate can be read directly from the scale on the tube. Refer to the scale mark to which the float adjusts its top edge when reading.

Maintenance:

With common applications and normal operating conditions the device is maintenance free. In case of soiling we recommend to clean the measuring tube by using a bottle brush and soap water. Make sure not to scratch the measuring tube. If float or measuring tube show signs of wear and tear, we recommend replacing them.

4.2 Piping

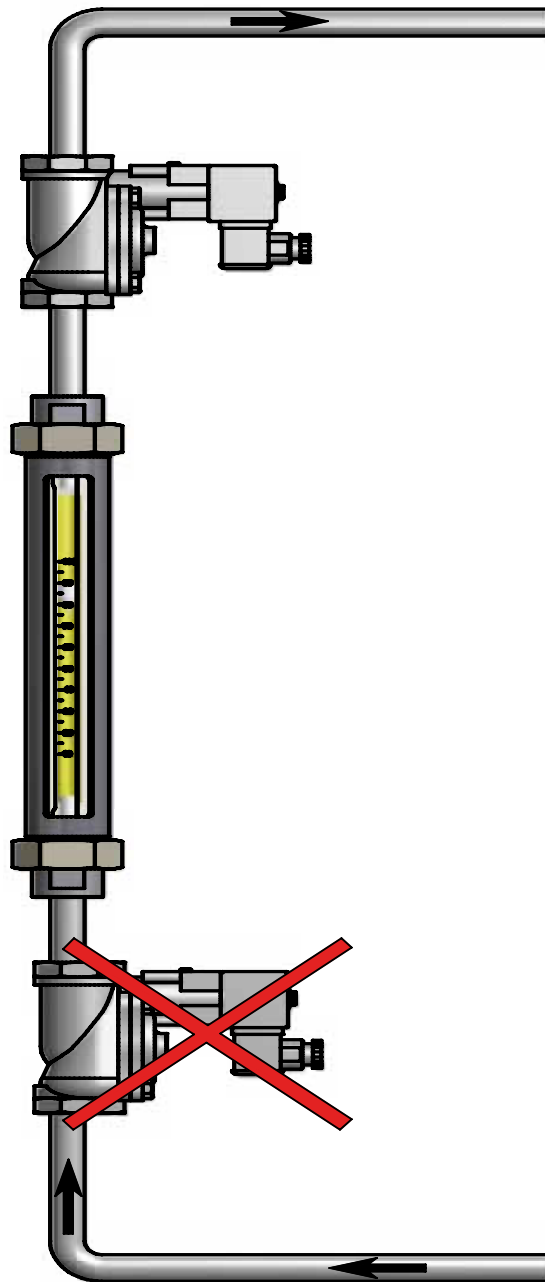
**IMPORTANT**

On/Off- valve must be installed downstream !

4.3 Bistable inductive ring sensor (Option /GR2 to /GR8)

- The ring sensor should be connected to a mono stable transmitter relay.
- Connection to transmitter relay (s. installation diagram below)
 - white cable → +
 - shielding → -
- The installation regulations in accordance with IEC 364 have to be taken into account.
- The shielding of the connection cable is not for earthing of the ring sensor. A ring sensor with a damaged cable insulation may not be used
- The device has to be protected from strong electromagnetic fields.
- Power lines have to be installed separated from the signal lines.
- Switches, power relays and engines can change the switching state of the ring sensor (in unfavorable orders).
- Metal parts should have a minimum distance of 50 mm to the ring sensor.
- If the float is above the ring sensor after power on or after power fail, the float has to move once through the ring sensor to find the correct float position.

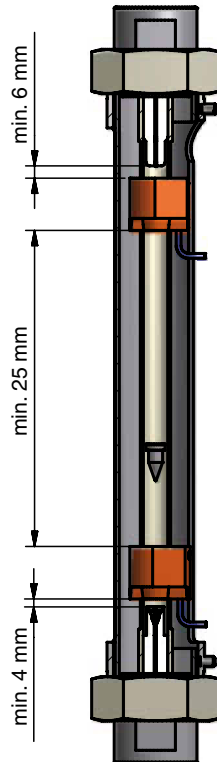

Connection to transmitter relay :

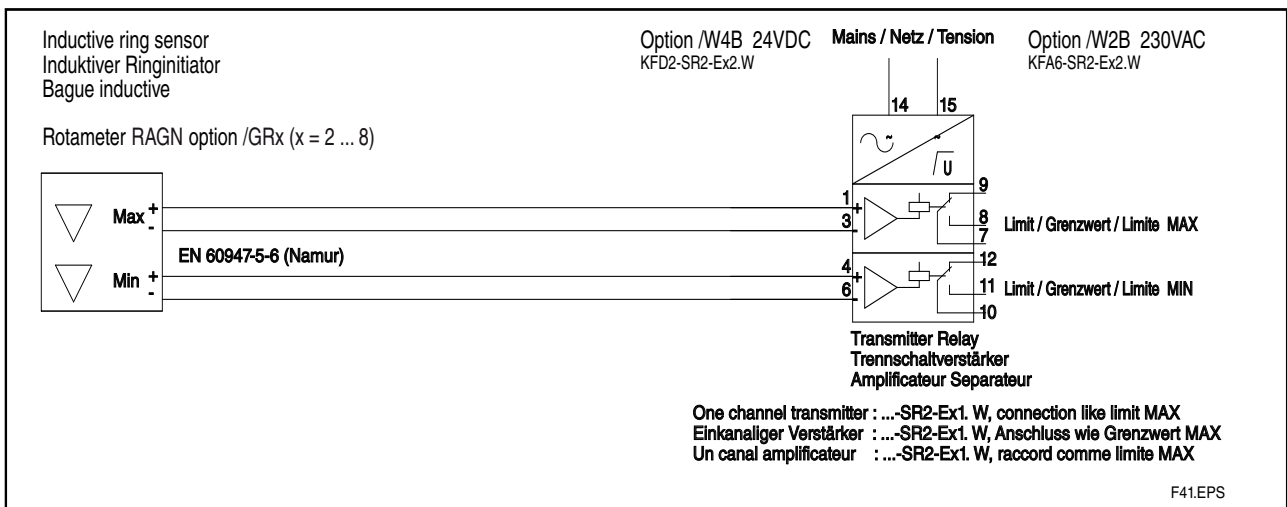

For installation in hazardous area see chapter 6 "EXPLOSION PROTECTED TYPE INSTRUMENTS"

4.4 Magnetic contact (Option /GM1 to /GM5)

- Loose the nut at the guide sleeve.
- If 2 limit switches were ordered install the Max-contact in the top position and the Min- contact in the low position (see print on housing).
- Put the limit switch from the outer side on the guide rail of the Rotameter.
- Adjust the distance between limit switch to tube to 1 mm; check function and correct if necessary.
- Fix limit switch with the nut to guide rail.

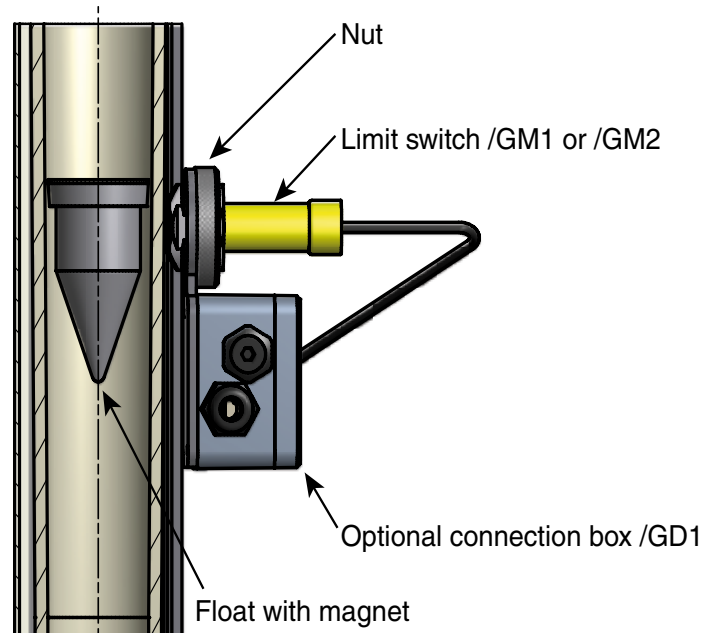

Connection to transmitter relay :

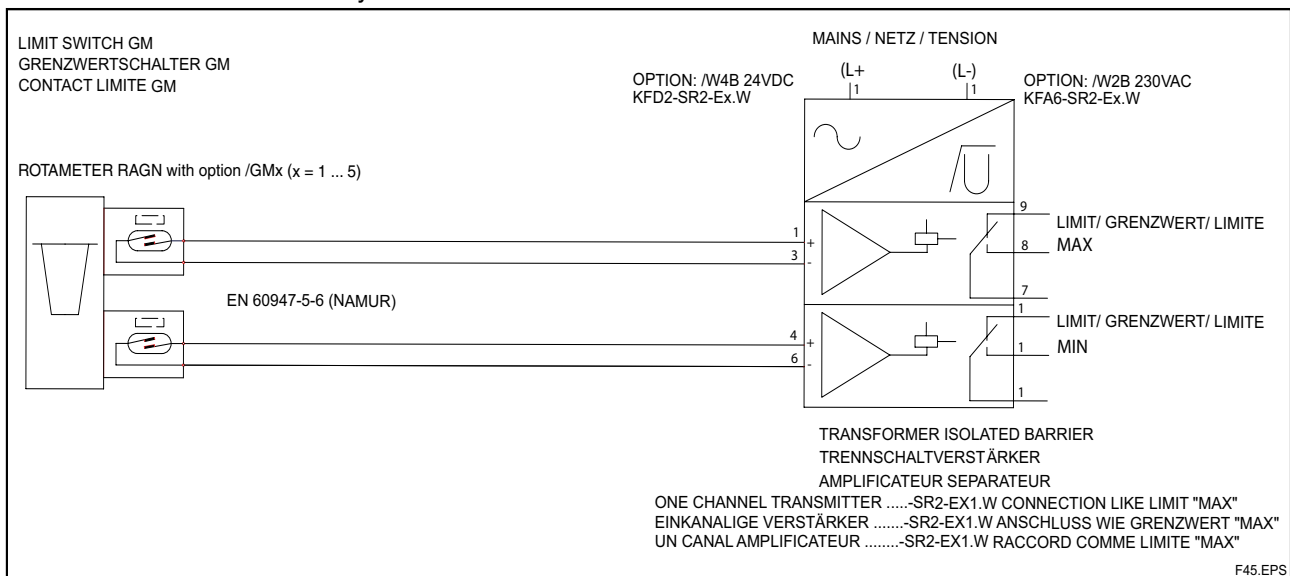

4.5 Connection box (Option /GD1 or /GD2)

For one limit switch the connection box with option /GD1 and for two limit switches the connection box with option /GD2 is available.

Please make the connections in the connection box as shown below.

Option /GD1

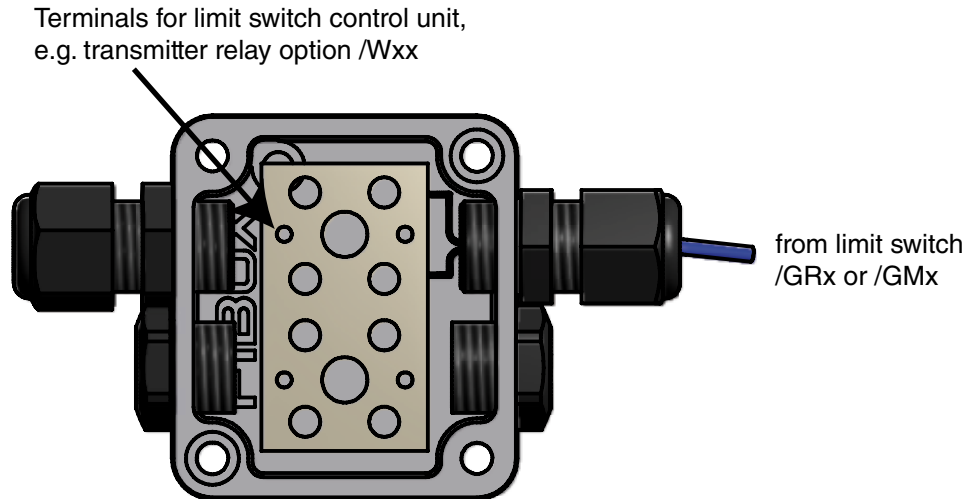

Option /GD2

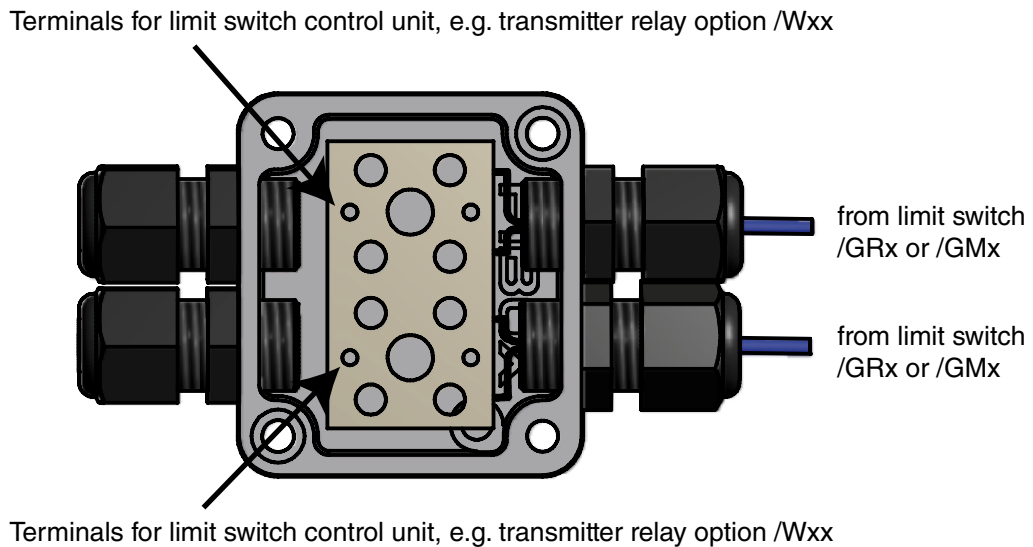

5. Service

5.1 Customer maintenance part list (CMPL)

L-TUBE :

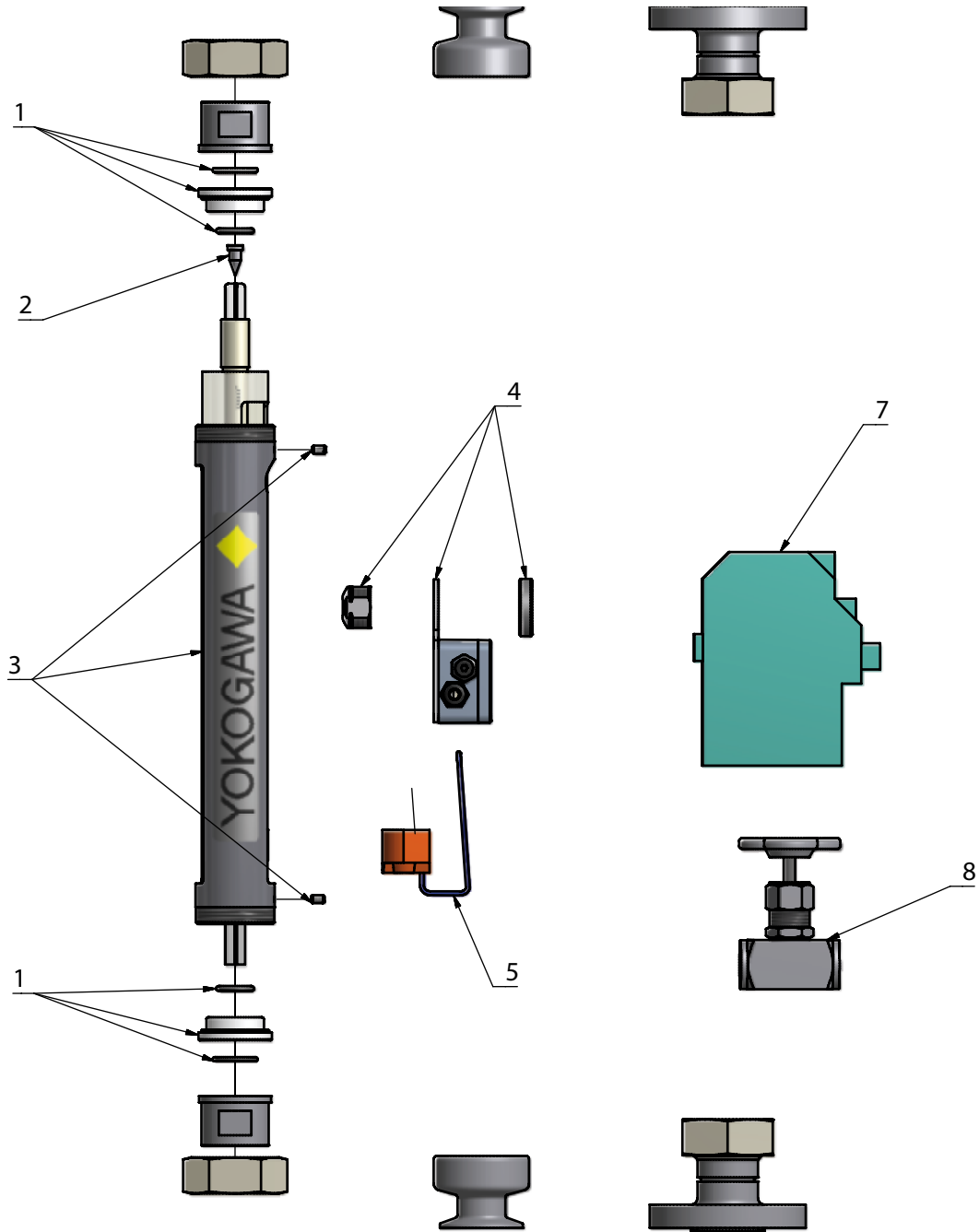

P-TUBE :

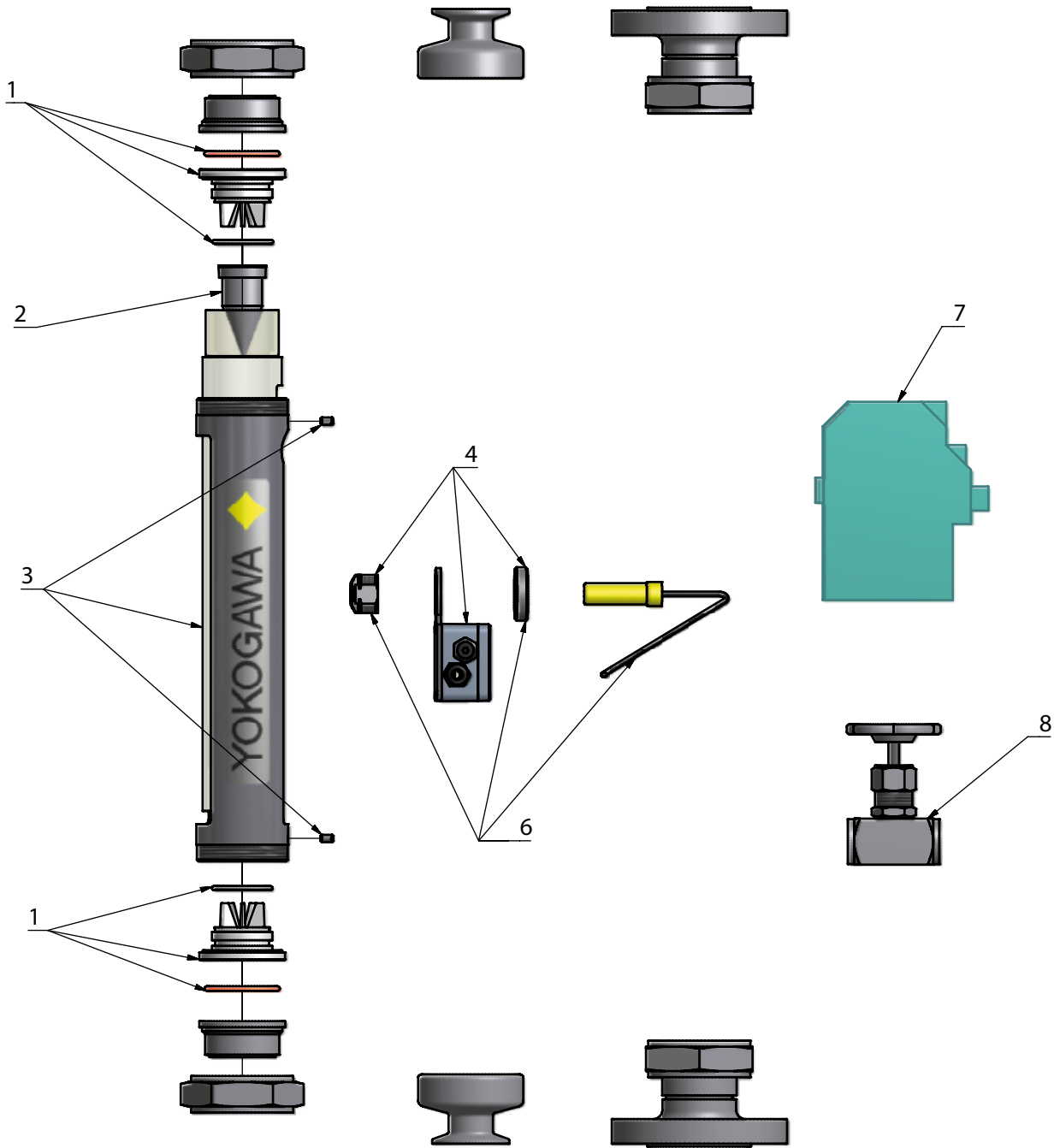

Item	Part-No.	Descriptions	L6 tube	L7 tube	P0 tube	P1 tube	P2 tube	P4 tube
1	M3810TA-SP	Set of bottom and top stoppers and Buna, Viton, EPDM gaskets for L6 tube	x					
	M3810TB-SP	Set of bottom and top stoppers and Buna, Viton, EPDM gaskets for L7 tube		x				
	M3810TC-SP	Set of bottom and top stoppers and Buna, Viton, EPDM gaskets for P0 tube			x			
	M3810TD-SP	Set of bottom and top stoppers and Buna, Viton, EPDM gaskets for P1 tube				x		
	M3810TE-SP	Set of bottom and top stoppers and Buna, Viton, EPDM gaskets for P2 tube					x	
	M3810TF-SP	Set of bottom and top stoppers and Buna, Viton, EPDM gaskets for P4 tube						x
2	M3810TK-SP	Spare float PD12M				x		
	M3809MK-SP	Spare float PD17M				x		
	M3810TL-SP	Spare float SS13N				x		
	M3810TM-SP	Spare float SS13M				x		
	M3810TN-SP	Spare float PF16N				x		
	M3809MC-SP	Spare float PD22M					x	
	M3809ME-SP	Spare float PD27M					x	
	M3810TP-SP	Spare float SS23N					x	
	M3810TQ-SP	Spare float SS23M					x	
	M3810TR-SP	Spare float PF26N					x	
	M3809MD-SP	Spare float PD42M						x
	M3809MF-SP	Spare float PD47M						x
	M3810TS-SP	Spare float SS43N						x
	M3810TT-SP	Spare float SS43M						x
M3810TW-SP	Spare float PF46N						x	
3	M3810TG-SP	Splinter shield incl. 2 slotted set screws with flat point for tube L6,L7,P0,P1	x	x	x	x		
	M3810TH-SP	Splinter shield incl. 2 slotted set screws with flat point for tube P2					x	
	M3810TJ-SP	Splinter shield incl. 2 slotted set screws with flat point for tube P4						x
4	M3810GM-SP	Connection box for 1 limit switch	x	x	x	x	x	x
	M3810GN-SP	Connection box for 2 limit switches	x	x	x	x	x	x
5	M3810TX-SP	Bistable inductive ring sensor for float PDB__ (/GR2 or /GR6))	x					
	M3810TY-SP	Bistable inductive ring sensor for float PDC__ (/GR3 or /GR7)		x				
	M3810TZ-SP	Bistable inductive ring sensor for float PDD__ (/GR4 or /GR8)		x				
6	M3810GD-SP	Magnetic MIN-contact for float with insertion code ____M (/GM1)			x	x	x	x
	M3810GE-SP	Magnetic MAX-contact for float with insertion code ____M (/GM2)			x	x	x	x
	M3810GF-SP	Magnetic MIN-MAX-contact for float with insertion code ____M (/GM3)			x	x	x	x
	M3810GG-SP	Magnetic MIN-MIN-contact for float with insertion code ____M (/GM4)			x	x	x	x
	M3810GH-SP	Magnetic MAX-MAX-contact for float with insertion code ____M (/GM5)			x	x	x	x
7	M3810WA-SP	Transmitter relay KFA5-SR2-Ex1.W / 115 V AC, 1 channel (/W1A)	x	x	x	x	x	x
	M3810WB-SP	Transmitter relay KFA5-SR2-Ex2.W / 115 V AC, 2 channel (/W1B)	x	x	x	x	x	x
	M3810WC-SP	Transmitter relay KFA6-SR2-Ex1.W / 230 V AC, 1 channel (/W2A)	x	x	x	x	x	x
	M3810WD-SP	Transmitter relay KFA6-SR2-Ex2.W / 230 V AC, 2 channel (/W2B)	x	x	x	x	x	x
	M3810WE-SP	Transmitter relay KFD2-SR2-Ex1.W / 24 V DC, 1 channel (/W4A)	x	x	x	x	x	x
	M3810WF-SP	Transmitter relay KFD2-SR2-Ex2.W / 24 V DC, 2 channel (/W4B)	x	x	x	x	x	x
8	M3810EQ-SP	Valve made of SS 316Ti (1.4571) G 1/2" (/V1)	x	x	x			
	M3810ER-SP	Valve made of SS 316Ti (1.4571) G 1" (/V2)				x		
	M3810ES-SP	Valve made of SS 316Ti (1.4571) G 1 1/2" (/V3)					x	
	M3810ET-SP	Valve made of brass G 1/2" (/V4)	x	x	x			
	M3810EW-SP	Valve made of brass G 1" (/V5)				x		
	M3810EX-SP	Valve made of brass G 1 1/2" (/V6)					x	
9	IM 01R01B10-00D-E	Printed Instruction Manual in German	x	x	x	x	x	x
	IM 01R01B10-00E-E	Printed Instruction Manual in English	x	x	x	x	x	x

5.2 Template for sending back to service

Sending an instrument back to service

Installation and operation of the Rotameter RAGN in compliance with this manual is generally trouble-free.

In case a RAGN has to be sent for repairs or checking to our service, please observe the following:

Due to legislation for the protection of the environment and for the safety of our staff, YOKOGAWA may only ship, repair and check sent devices on the condition that this does not constitute any risk to environment and staff.

YOKOGAWA can only process your returned RAGN if you attach a certificate of harmlessness according to the following sample.

If the unit has been in contact with corrosive, poisonous, flammable or water polluting substances, you must,

- ensure that all parts and hollow spaces of the unit are free of these dangerous substances.
- attach a certificate of harmlessness to the returned unit.

Please understand that YOKOGAWA cannot process your returned unit without such a certificate.

ROTA YOKOGAWA GmbH & Co. KG
 Service & Repair Department
 Rheinstraße 8; D - 79664 Wehr
 Phone no.: +49 (0)7761-567-190
 Fax no.: +49 (0)7761-567-285
 e-Mail: services.flow@de.yokogawa.com



Declaration of Decontamination

Legal regulations for the safety of our employees and operating equipment determine that we need the declaration of decontamination before your order can be handled.
Please make sure to include it with the shipping documents, attached to the outside of the packaging you use for shipment.

Customer data		
Company:		
Address:		
Contact person:	E-Mail:	
Phone no.:	Fax no.:	
Reference/Order no.:		
Instrument data*		
Type:	Serial no.:	
Type:	Serial no.:	
<small>*If not enough, note on separate sheet</small>		
Process data		
Process medium:		
Medium is:	<input type="checkbox"/> toxic <input type="checkbox"/> corrosive <input type="checkbox"/> explosive <input type="checkbox"/> biological hazardous <input type="checkbox"/> unknown if dangerous <input type="checkbox"/> non hazardous	Remarks:
Cleaning agent:		
Kind of cleaning :		
Other remarks / Reason of return:		

We hereby confirm that this statement is filled in completely and truthfully. The returned instruments were carefully cleaned and are thus free from product residue and dirt. I agree that if this arrangement does not match with the instruments, they will be sent back to the above mentioned customer address at our expenses.

Name	Date	Signature

Blank Page

6. Explosion protected type instruments

6.1 Bistable inductive ring sensor (Option /GR2 to /GR8)



WARNING



- Only trained persons may use the instrument in the industrial area.
- It is forbidden to users to carry out specification changes and other changes at the device. Repairs at the device aren't permitted.
- To ensure explosion protection of the RI20, a suitable explosion-proof transmitter relay must be used.
- The maximum ambient temperature and the maximum temperature of the medium, which flows through the tube, may not exceed 60°C.
- The connection cable may not be exposed to mechanical loads. The maximum axial strength is 30 N.

The inductive ring sensor RI20 is an intrinsic safe device. This is certified for hazardous areas of zone 1 (category 2) and zone 2 (category 3). They are not homologated for zone 0 (category 1). The classifications in brackets are given according to EU- Regulation 94/9/EG (ATEX).

Temperature range : -25°C to +60°C

EC- Type Examination Certificate number: PTB 03 ATEX 2111

The identification in accordance with regulation 94/9/EG (ATEX)

- Manufacturer : Rota Yokogawa, Rheinstr. 8, D-79664 Wehr
- Type : RI20-10 or RI20-17
- Serial number and year of the production:
7yymmxxx (yy=year, mm=month, xxx= incremented number (e.g. 70309001)
- Protection : Ex ia
- Group : IIC
- Category : 2
- Explosive atmosphere : G
- Temperature class : T6
- Certificate No. : PTB 03 ATEX 2111
- Entity parameters : $U_i = 12 \text{ V}$, $I_i = 22 \text{ mA}$, $P_i = 66 \text{ mW}$,
 $L_i = 20 \text{ mH}$, $C_i = 200 \text{ nF}$
or
see certificate for data
- Marking according to regulation 94/9/EG :    II 2 G



WARNING

- The electrical connection of the RI20 is provided with free ends of the cables with cable hulls. Please regard the installation regulations in accordance with IEC 364.
- The shielding of the connection cable is not for grounding of the RI20. A RI20 with damaged cable isolation may not be used.
- Static charges of the RI20 housing have to be avoided. A corresponding warning note has to be attached at the device.

Installation in Hazardous area:

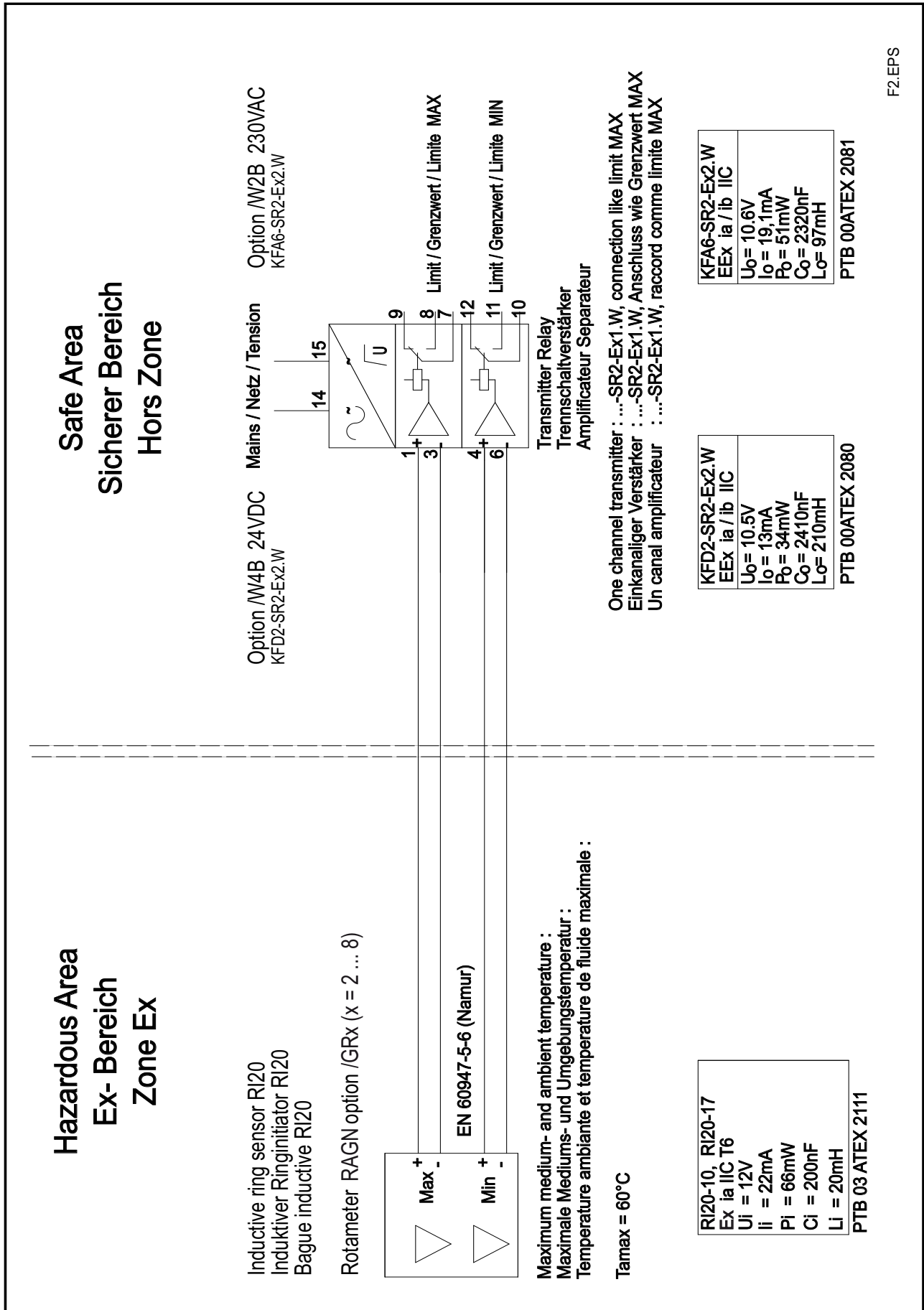

F2.EPS

Marking:

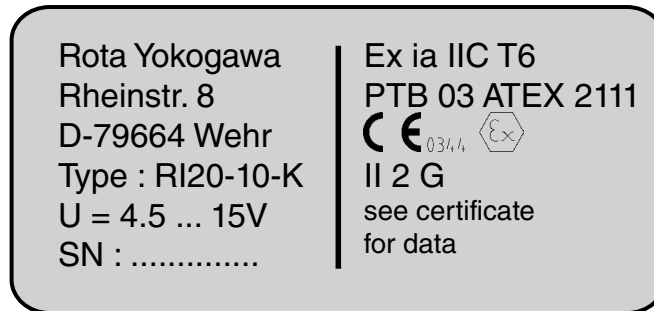

6.2 Magnetic contact (Option /GM1 to /GM5)



WARNING

- Only trained persons may use the instrument in the industrial area.
- It is forbidden to users to carry out specification changes and other changes at the device. Repairs at the device aren't permitted.
- To ensure explosion protection of the GM, a suitable explosion-proof transformer isolated barrier must be used.
- The maximum ambient temperature and the maximum temperature of the medium, which flows through the tube, may not exceed 70°C.
- The connection cable may not be exposed to mechanical loads. The maximum axial strength is 30 N.
- Static charge of the GM case has to be avoided. A corresponding warning note has to be attached at the device.

The limit switch GM is classified according EN 60079-11 chapter 5.7, IEC 60079-11 chapter 5.7 and ANSI/ISA 60079-11 chapter 5.7 as "Simple Apparatus".

For use in hazardous area the limit switch must be connected to a suitable explosion-proof transformer isolated barrier, which does not exceed the following maximum values :

Maximum voltage U_0 : 15 V
 Maximum current I_0 : 50 mA
 Maximum power P_0 : 187 mW

Classification :

- Type : GM1 or GM2
- Protection : intrinsic safe
- ATEX / IECEx : IIC 2G
- FM : I, 1, A, B, C, D
- Temperature class : T6
- Entity parameters : $U_i = 15 \text{ V}$; $I_i = 50 \text{ mA}$; $P_i = 187 \text{ mW}$; $L_i \approx 0 \text{ mH}$; $C_i \approx 0 \text{ nF}$

Installation in Hazardous area:

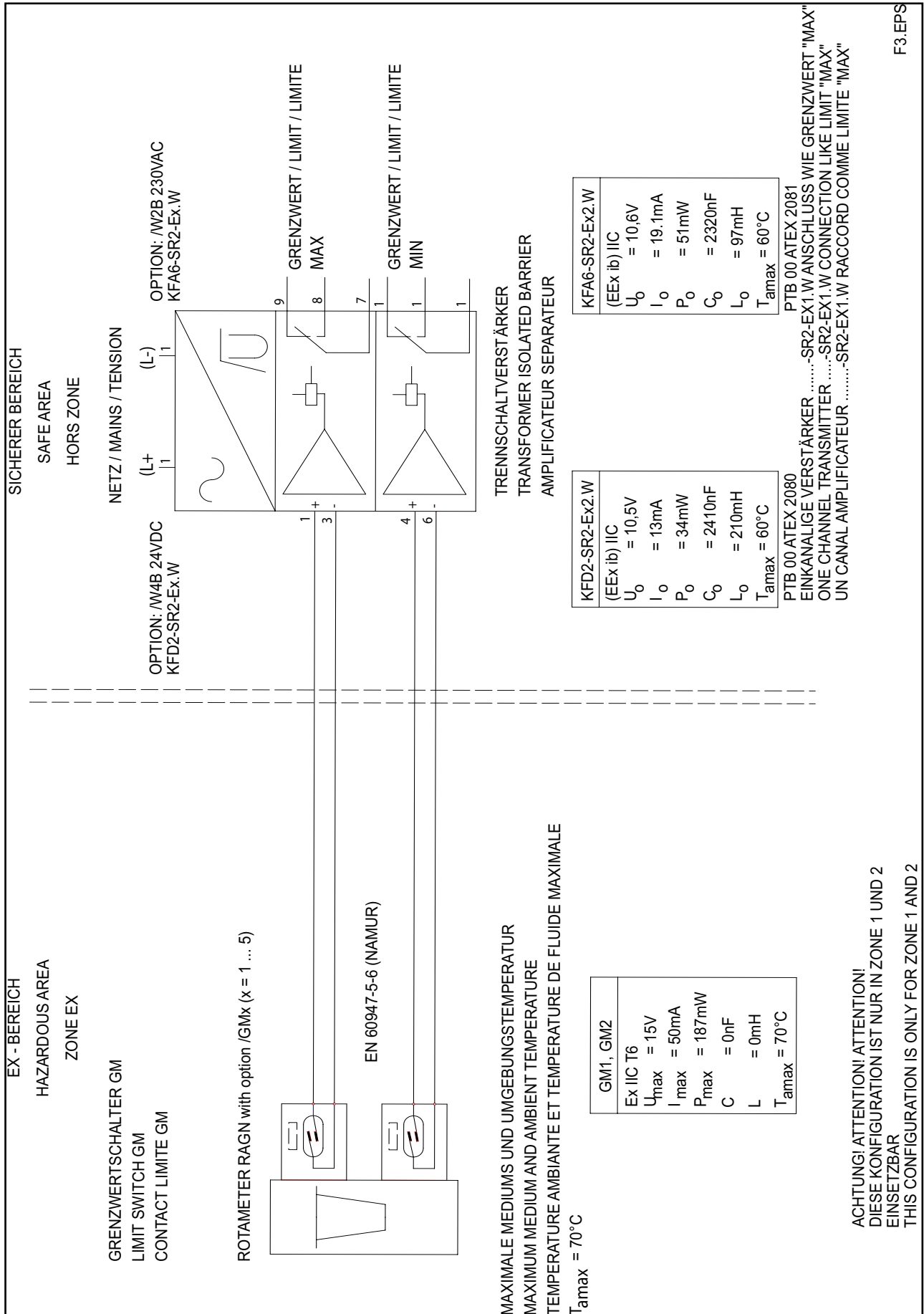

7. Instructions for PED

The meters RAGN 04-..., RAGN05-... and RAGN06-... are produced according the determinations of directive 97/23/EG (directive for Pressure – Equipment / PED).

The units are classified as pipe according item 3, number 1, 3. letter, a) first dash or according diagram 6 after appendix II :

- Classification as pipe
- For Fluid Group 1 (article 9 chapter (2)).
- Medium fluid and gas

The basic safety requests (for design, production and testing) for all units according to category I are generally determined for the requests of category I.

The units, which are not excluded by PED article 3 paragraph 3, are checked by a conformity-valuation-method according appendix III 'module A'.



IMPORTANT

The user is responsible for the use of our flowmeters regarding suitability and use as agreed.

8. Technical Data

STANDARD SPECIFICATIONS

Fluids to be measured : Liquids and gas

Measurable flow rates :

- Water (20 °C) : 0.002 l/h to 10 m³/h
- Air (20 °C; 1 bar abs.) : 0.1 l/h to 160 m³/h

Turndown :

- P metering tube : 10:1
- L metering tube : 20:1

Metering tubes : L6; L7; P0; P1; P2; P4 (length 300 mm)

Process temperature : -25°C to +100°C

Process pressure :

Metering tube	L6;L7	P0;P1	P2	P4
Pmax (bar)	16	10	8	6

Installation length :

Process connection	Thread	Clamp	Flange
Length [mm]	375	375	425

Weight : Depending on design (see page 7)

Accuracy :

Tube	Measuring accuracy acc. Directive VDI/VDE 3513 sheet 2 (q _g = 50%)
L613 - L623	2.5%
L624 - L747	1.6%
P051 - P471	1.6%

Materials :

- Threads G, NPT : AISI 316L (1.4404)
- Flange EN / ASME : AISI 316L (1.4404)
- Clamp ISO 2852 : AISI 316L (1.4404)
- Housing : AISI 304 (1.4301)
- Nut : AISI 316 (1.4401) (or galvanized steel)
- Stoppers (L6, L7 tube) : PFA
- Stoppers (P0 - P4 tube) : PVDF, AISI 316L (1.4404)
- Measuring cone : Borosilicate glass
- Float (L6, L7 tube) : Titanium, PVDF
- Float (P0 - P4 tube) : PTFE, PVDF (FDA conform), AISI 316Ti (1.4571)
- Gaskets : NBR, FKM, EPDM (FDA conform)

Pressure Equipment Directive (PED) Directive 97/23/EG:

- Models : RAGN04, RAGN05, RAGN06
- Tubes :

 - Modul : A
 - Fluid Group : 1 (liquid, gases)
 - Produced acc. to category : I

FDA-Conformity:

- RAGN with P- tube, PVDF- or SS- float and EPDM- gaskets (option /ME).
- Stoppers and floats made of PVDF: 21 CFR § 177 2510(a)
- O-rings made of EPDM: 21 CFR § 177 2600-21

Compliance with safety application acc. IEC 61508: 2010 and ISO 13849:

Please refer to the FMEDA report and instruction manual.

OPTION SPECIFICATIONS

Limit switch (option /GM1 to /GM5):

(for P- tubes with PVDF- or SS- float with magnet only)

- Type : reed contact with bistable switching
- Max. switching voltage : 230 V
- Max. switching current : 2 A
- Max. switching capacity: 40 W/VA
- Temperature range : -10°C to +70°C
- Protection : IP65
- Internal capacity : 0 nF
- Internal inductivity : 0 mH
- Electrical connection : LIYY 2 x 0.34 mm²; length 1 m
- Housing : Polystyrene
- Weight : 35 g
- Explosion proof :

 - Intrinsic safe acc. EN 60079-11 chapter 5.7, IEC 60079-11 chapter 5.7 and ANSI/ISA 60079-11 chapter 5.7 as "Simple Apparatus".

- Group : IIC
- Category : 2G
- Temperature class : T6
- Entity parameter : U_i = 15 V ; I_i = 50 mA ; P_i = 187 mW
L_i ≈ 0 mH ; C_i ≈ 0 nF

Limit switch (option /GR2 to /GR8):

(for L- tubes with PVDF float only)

- Type : Bistable inductive ring sensor
- Power supply : 4.5 V to 15 V DC
- Consumption : acc. DIN EN 60947-5-6 (NAMUR)
- Float below ring sensor: < 1 mA
- Float above ring sensor: > 2.2 mA
- Temperature range : -25°C to +65°C non-Ex- type
- Protection : IP 67
- Electrical connection : 2 x 0.14 mm² , with shield 0.4 mm², 2 m long
- Explosion proof type (option /KS1):

 - Temperature range : -25°C to +60°C
 - Marking acc. guideline 94/9/EG :

- Manufacturer : Rota Yokogawa, Rheinstr.8, D-79664 Wehr
- Type : RI20-10K/G or RI20-17K/G
- Year of production : in serial number
- Protection : Ex ia
- Group : IIC
- Category : 2G
- Temperature class : T6
- Certificate No. : PTB 03ATEX 2111
- Safety relevant data (see also certificate for data):
U_i = 12 V, I_i = 22 mA , P_i = 66 mW,
L_i = 20 mH, C_i = 200 nF

CE-marking

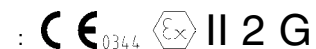
: 

Power supply for limit switch (option /W__):

- Type : acc. DIN EN 60947-5-6 (NAMUR)

 - KFA5-SR2-Ex*-W (115 V AC), * = 1 or 2
 - KFA6-SR2-Ex*-W (230 V AC), * = 1 or 2
 - KFD2-SR2-Ex*-W (24 V DC), * = 1 or 2
 - KHA6-SH-Ex1 (115/230 V AC), Fail Safe, 1 channel
 - KFD2-SH-Ex1 (24 V DC), Fail Safe, 1 channel

Power supply :

- 230 V AC ± 10%, 45-65Hz
- 115 V AC ± 10%, 45-65Hz
- 24 V DC ± 25%

Relay output :

- 1 or 2 potential-free changeover contact(s)

Switching capacity :

- max. 250 V AC, max. 2 A

Explosion proof : Intrinsic safe [Ex ia] IIC
 PTB 00 ATEX 2081 (/W1A, /W1B, /W2A, /W2B)
 PTB 00 ATEX 2080 (/W4A, /W4B)
 PTB 00 ATEX 2042 (/W4E, /W4F)
 PTB 00 ATEX 2043 (/W2E, /W2F)

Note :
 For safety application fail safe power supply option /W2E, /W2F, /W4E or /W4F must be selected in combination with options /GR_.

MODEL SPECIFICATIONS

Model	Suffix code	Description	Restrictions
RAGN01 RAGN23 RAGN02 RAGN04 RAGN05 RAGN06		Size DN 15 (½ inch) Size DN 20 (¾ inch) Size DN 25 (1 inch) Size DN 40 (1½ inch) Size DN 50 (2 inch) Size DN 65 (2½ inch)	for D4, A1, G0, T0, S4 with L6, L7, P0, P1 for G0, T0 with L6, L7, P0, P1 for D4, A1, G0, T0, S4 with L6, L7, P0, P1, P2 for D4, A1, G0, T0 with P2, P4 for D4, A1, with P2, P4; for G0, T0 with P4 for G0, T0 with P4
Process connection	-D4 -A1 -G0 -T0 -S4	EN flange PN 40, process connection dimension + facing acc. EN 1092-2 Form B1 ASME flange class 150, process connection dimension + facing acc. ASME B 16.5 Inner thread G Inner thread NPT Clamp ISO 2852	
Material of process connections	SS	Stainless steel	
Metering tube ¹⁾	-L -P	L-tube (300 mm) P-tube (300 mm)	
Diameter of metering tube ¹⁾	6 7 0 1 2 4	10 mm 17 mm 20 mm 34 mm 48 mm 81 mm	
Cone ¹⁾	13 14 17 21 22 23 24 27 31 32 33 34 37 41 42 43 44 47 51 52 53 54 57 61 62 63 64 67 71		
Float material ¹⁾	-SS -PF -PD -TT	1.4571 / AISI 316 Ti PTFE PVDF Titanium	
Diameter of float ¹⁾	A B C D 0 1 2 4	1.59 3.18 6.35 9.53 12.2 (P0-float) 21.6 (P1-float) 31.2 (P2-float) 54.1 (P4-float)	
Medium / Float factor ¹⁾	L G 2 3 6 7	For liquid For gas For water For water For air For air	
Float insertion ¹⁾	N M	Without magnet With magnet	

¹⁾ Combinations see tables on page 8-3 and 8-4

FLOW TABLE WITH METERING TUBE-FLOAT-COMBINATION FOR WATER / LIQUIDS

Flow table		Suffix code metering tube - float- combination									
Water / liquids 20°C		Metering tube			Float						
Max. Flow [l/h]	Pressure loss [mbar]	-x	x	xx	-xx	x	x	x			
		Length	Diameter	Cone	Material	Diameter	Flow mark	Insertion			
		Code	Code	Code	Code	Code	Code	Code			
0.025	1	L	6	13	TT	A ¹⁾	L	N			
0.04	1	L	6	14							
0.063	2	L	6	17							
0.1	2	L	6	21							
0.16	3	L	6	22							
0.25	4	L	6	23							
0.4	1	L	6	24	TT;PD	B	L				
0.63	1	L	6	27							
1	2	L	6	31							
1.6	3	L	6	32							
2.5	4	L	6	33							
4	2	L	7	34							
6.3	2	L	7	37		C	L				
10	3	L	7	41							
16	4	L	7	42							
25	5	L	7	43							
40	5	L	7	44							
63	10	L	7	47							
63	10	P	0	51	PD	0	2	M			
100	16	P	0	52	SS		3	M ²⁾ ; N			
100	16	P	0	51							
160	24	P	0	52							
160	15	P	1	53	PD	1	2	M			
250	16	P	1	54							
400	18	P	1	57							
630	26	P	1	61							
250	15	P	1	53					SS	3	M ²⁾ ; N
400	16	P	1	54							
630	18	P	1	57							
1000	26	P	1	61							
1000	11	P	2	62	PD	2	2	M			
1600	13	P	2	63	SS		3	M ²⁾ ; N			
1600	26	P	2	62							
2500	30	P	2	63	PD	4	2	M			
2500	16	P	4	64							
4000	18	P	4	67							
6300	21	P	4	71							
4000	40	P	4	64					SS	3	M ²⁾ ; N
6300	44	P	4	67							
10000	53	P	4	71							
	Description										
Length metering tube	300 mm	P									
	300 mm	L									
Diam. metering tube	10 mm to 81 mm		x								
Cone metering tube	See flow table			xx							
Float material	1.4571				SS						
	Titanium				TT						
	PTFE				PF						
	PVDF				PD						
Float diameter	1.6 mm to 54 mm					x					
Flow mark	For liquid						L				
	For water						2				
	For water						3				
Float insertion	Without magnet							N			
	With magnet							M ²⁾			

¹⁾ Max. viscosity 2 mPas*s

²⁾ For option limit switch /GM1 to /GM5

FLOW TABLE WITH METERING TUBE-FLOAT-COMBINATION FOR AIR / GASES

Flow table		Suffix code metering tube - float- combination						
Air/Gases 20°C, 1 bar abs		Metering tube			Float			
Max. Flow [l/h]	Pressure loss [mbar]	-x	x	xx	-xx	x	x	x
		Length Code	Diameter Code	Cone Code	Material Code	Diameter Code	Flow mark Code	Insertion Code
1.9	1	L	6	13	TT	A	G	N
3	1	L	6	14				
4.4	2	L	6	17				
6.5	2	L	6	21				
10	3	L	6	22				
14	4	L	6	23				
23	2	L	6	24	PD;TT	B	G	
33	2	L	6	27				
50	2	L	6	31				
70	3	L	6	32				
100	4	L	6	33				
180	3	L	7	34		C	G	
250	3	L	7	37				
400	3	L	7	41				
630	4	L	7	42				
1000	5	L	7	43				
1600	5	L	7	44	0	G		
2400	10	L	7	47				
1600	4	P	0	51	PF	6	M ¹⁾	
2500	6	P	0	52	PD			
2400	8	P	0	51		7		
3800	11	P	0	52				
6000	6	P	1	53	PD	1	7	M ¹⁾
9300	7	P	1	54				
14500	8	P	1	57				
23000	10	P	1	61				
400	5	P	1	53	PF	1	6	N
6300	5	P	1	54				
10000	6	P	1	57				
16000	8	P	1	61				
35000	11	P	2	62				
55000	13	P	2	63				
25000	8	P	2	62	PF	2	6	N
40000	10	P	2	63				
88000	29	P	4	64				
140000	32	P	4	67				
220000	34	P	4	71				
63000	13	P	4	64	PF	4	6	N
100000	14	P	4	67				
160000	17	P	4	71				
	Description							
Length metering tube	300 mm	P L						
	300 mm							
Diam. metering tube	10 mm to 81 mm		x					
Cone metering tube	See flow table			xx				
Float material	Titanium				TT			
	PTFE				PF			
	PVDF				PD			
Float diameter	1.6 mm to 54 mm					x		
Flow mark	For gas						G	
	For air						6	
	For air						7	
Float insertion	Without magnet							N
	With magnet							M ¹⁾

¹⁾ For option limit switch /GM1 to /GM5

OPTIONS

Options	Option Code	Description	Restriction
Marking	/B1	Tag plate (SS)	Plate 12 x 40 mm; max. 45 digits Not with /KS1 Max. 45 digits Only for tube P
	/B4	Neutral version	
	/BG	Customer specific notes on name plate	
	/B10	Percentage scale	
	/BD	Dual scale	
Limit switches	/GM1	Magnetic MIN-contact	Only for tube P0 to P4 and float insertion code M (with magnet) Only for tube P0 to P4 and float insertion code M (with magnet) Only for tube P0 to P4 and float insertion code M (with magnet) Only for tube P0 to P4 and float insertion code M (with magnet) Only for tube P0 to P4 and float insertion code M (with magnet) Only for tube L6 with float code PDB Only for tube L7 with float code PDC Only for tube L7 with float code PDD Only for tube L6 with float code PDB Only for tube L7 with float code PDC Only for tube L7 with float code PDD Only with /GM1 to 2, /GR2 to 4 Only with /GM3 to 5, /GR6 to 8
	/GM2	Magnetic MAX-contact	
	/GM3	Magnetic MIN-MAX-contact	
	/GM4	Magnetic MIN-MIN-contact	
	/GM5	Magnetic MAX-MAX-contact	
	/GR2	Bistable inductive ring sensor	
	/GR3	Bistable inductive ring sensor	
	/GR4	Bistable inductive ring sensor	
	/GR6	2 bistable inductive ring sensors	
	/GR7	2 bistable inductive ring sensors	
	/GR8	2 bistable inductive ring sensors	
	/GD1	Connection box for 1 limit switch	
/GD2	Connection box for 2 limit switches		
Ex-proof type	/KS1	ATEX intrinsically safe „ia“	Only for /GR2 to /GR8
Installation lengths (s. also table on page 8-6)	/L12	Installation length 500 mm	Only for D4, A1
	/L13	Installation length 356 mm	Only for size 01 and G0, T0
	/L14	Installation length 368 mm	Only for size 01, 23, 02 and G0, T0
	/L15	Installation length 386 mm	Only for size 02, 04 and G0, T0
	/L16	Installation length 394 mm	Only for size 05, 06 and G0, T0
Valves (inner thread, double fitting is attached, not for FDA)	/V1	Valve made of 1.4571 G 1/2" (parts attached)	Only for G0 and tube L6, L7, P0
	/V2	Valve made of 1.4571 G 1" (parts attached)	Only for G0 and tube P1
	/V3	Valve made of 1.4571 G 1 1/2" (parts attached)	Only for G0 and tube P2
	/V4	Valve made of brass G 1/2" (parts attached)	Only for G0 and tube L6, L7, P0
	/V5	Valve made of brass G 1" (parts attached)	Only for G0 and tube P1
	/V6	Valve made of brass G 1 1/2" (parts attached)	Only for G0 and tube P2
Test and certificates	/H1	Oil + fat free for wetted surfaces acc. Yokogawa specification	Only for insertion and flange connections Not with /V1 to /V6 Only for connections G0, T0, S4 except RAGN04-G0SS-P2 and RAGN04-T0SS-P2 Only for connections A1, D4 and RAGN04-G0SS-P2 and RAGN04-T0SS-P2
	/P2	Certificate of Compliance with the order acc. EN 10204: 2004- 2.1	
	/P3	As /P2 +Test report acc. to EN 10204: 2004- 2.2	
	/P6	Material certificate for Insertion parts or flange connections acc. EN 10204: 2004- 3.1	
	/PP	Pressure test report for metering system With flow table for recalculation + mm- scale	
	/PM2	PAMI test (2 test points)	
	/PM4	PAMI test (4 test points)	
Delivery to Korea	/KC	With KC-mark in Korea	
Accessories for metering tube	/MV	Gasket FKM (Viton)	conform with FDA -30°C to +100°C not for S4 and RAGN04 with P2
	/ME	Gasket EPDM (conform to FDA, -30°C to +100°C)	
	/MN	Nut galvanized steel	
Power supply for limit switches (transmitter relay)	/W1A	KFA5-SR2-Ex1.W / 115 V AC, 1 channel	
	/W1B	KFA5-SR2-Ex2.W / 115 V AC, 2 channel	
	/W2A	KFA6-SR2-Ex1.W / 230 V AC, 1 channel	
	/W2B	KFA6-SR2-Ex2.W / 230 V AC, 2 channel	
	/W2E	KHA6-SH-Ex1 / 115/230 V AC, 1 channel, Fail Safe	
	/W2F	2x KHA6-SH-Ex1 / 115/230 V AC, 1 channel, Fail Safe	
	/W4A	KFD2-SR2-Ex1.W / 24 V DC, 1 channel	
	/W4B	KFD2-SR2-Ex2.W / 24 V DC, 2 channel	
	/W4E	KFD2-SH-Ex1 / 24 V DC, 1 channel, Fail Safe	
/W4F	2x KFD2-SH-Ex1 / 24 V DC, 1 channel, Fail Safe		
Instruction manuals	/IE n	Quantity of instruction manuals in English	n = 1 to 9 selectable *)
	/ID n	Quantity of instruction manuals in German	n = 1 to 9 selectable *)
Special order	/Z	Special design must be specified in an extra text.	

*) If no instruction manual is selected, only a Short IM and in case of limit switches a CD with instruction manuals is shipped with the flowmeter.

PROCEDURE TO SELECT THE MODEL CODE

Please specify in the following order

- Measuring range for water/liquid or air/gas
- With or without optional limit switch

First select the required measuring range from the flow table (last column) and specify the float insertion for the optional limit switch. Then the suffix code for the combination metering tube - float can be fixed.

To size the Rotameter for other medium - process- conditions use sizing program Durep V.

DIMENSIONS

METERING TUBE

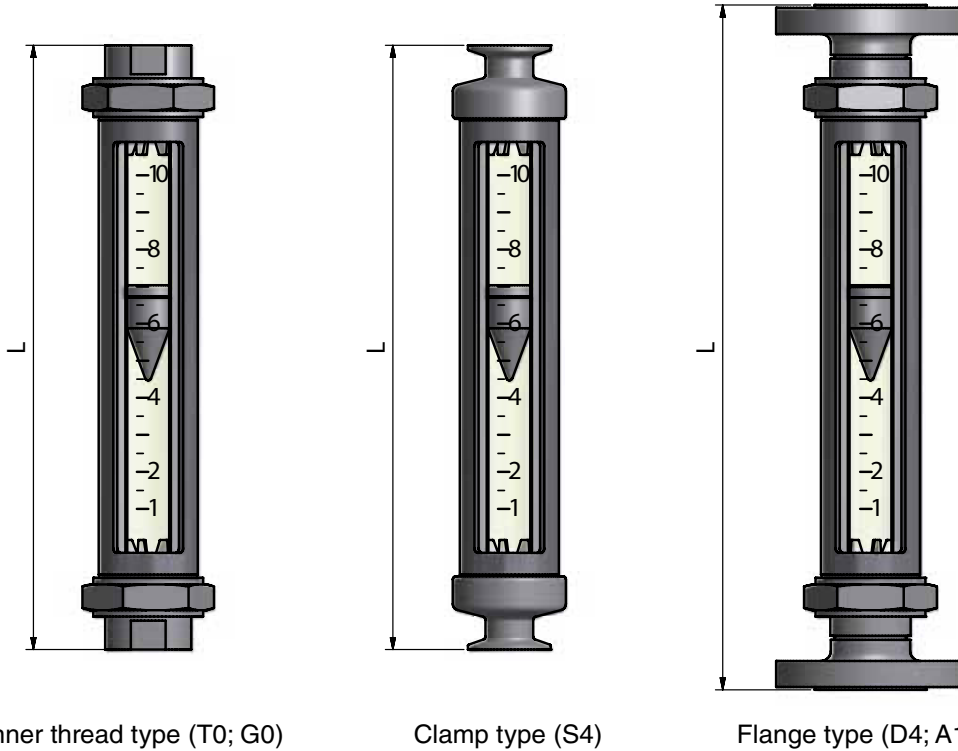

Inner thread type (T0; G0)

Clamp type (S4)

Flange type (D4; A1)

Installation lengths and weights:

Model	Process connection	Tube	Length L mm	Weight kg	
RAGN01	Inner thread	L6; L7; P0; P1	375	1.7	
	Clamp		375	1.9	
	Flange		425	2.5	
RAGN23	Inner thread		375	1.7	
RAGN02	Inner thread	L6; L7; P0; P1	375	1.7	
		P2		2.6	
	Clamp	L6; L7; P0; P1		2.0	
		P2		2.8	
	Flange	L6; L7; P0; P1		425	3.3
		P2			3.9
RAGN04	Inner thread	P2	375	2.6	
		P4		7.1	
	Flange	P2	425	5.2	
		P4		8.7	
RAGN05	Inner thread	P4	375	7.1	
	Flange	P2	425	6.6	
P4		11.1			
RAGN06	Inner thread	P4	375	7.1	

Compatibility with former Rotameter RAGG / RAGH:

Former model	Tube	Installation length mm	Model RAGN
RAGH01	L6;L7;G0	356	RAGN01.../L13
RAGH02	G1	368	RAGN02.../L14
RAGH04	G2	386	RAGN04.../L15
RAGH06	G4	394	RAGN06.../L16
RAGH23	G1	368	RAGN23.../L14
RAGH05	G4	394	RAGN05.../L16
RAGG01	G0;G1	500	RAGN01.../L12
RAGG02	G2	500	RAGN02.../L12
RAGG04	G4	500	RAGN04.../L12

VALVE /Vx

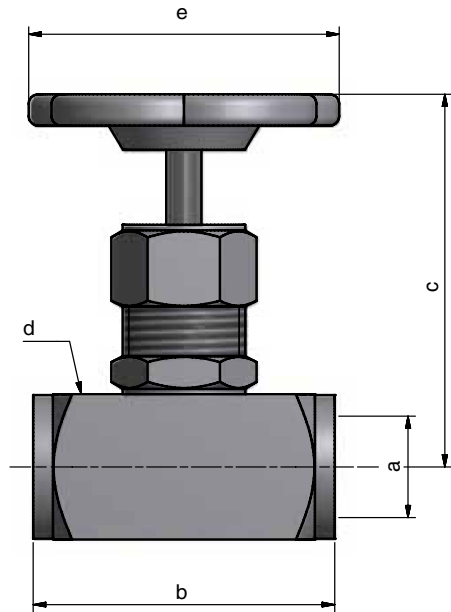

Option	a Thread	b mm	c mm	d mm	e mm
/V1	G 1/2"	60	88	SW 30	63
/V2	G 1"	100	110	SW 45	90
/V3	G 1 1/2"	130	145	SW 70	100
/V4	G 1/2"	55	78	SW 25	63
/V5	G 1"	75	93	SW 41	63
/V6	G 1 1/2"	110	118	SW 60	90

LIMIT SWITCH /GRx

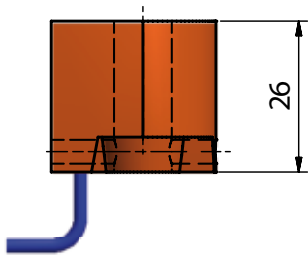

16 /GR2, /GR6
19.5 /GR3, /GR4, /GR7, /GR8

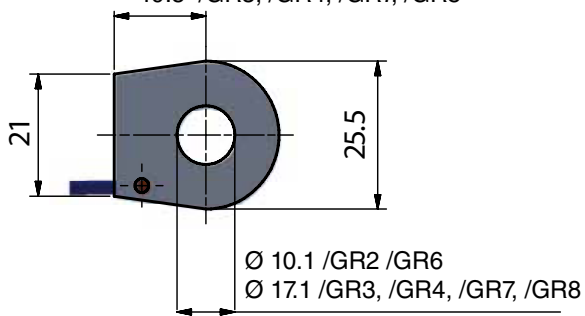

LIMIT SWITCH /GMx

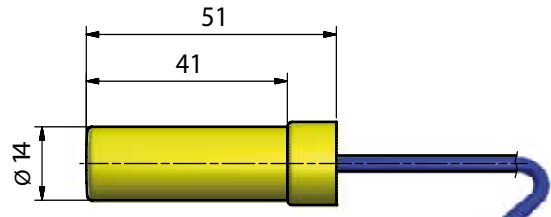

Blank Page

APPENDIX 1. Safety Instrumented Systems Installation

WARNING

The contents of this appendix are cited from exida.com safety manual on the Rotameter RAGN Flowmeter specifically observed for the safety transmitter purpose. When using the RAGN for Safety Instrumented Systems (SIS) application, the instructions and procedures in this section must be strictly followed in order to preserve the meter for that safety level.

A1.1 Scope and Purpose

This document provides an overview of the user responsibilities for installation and operation of the Rota Yokogawa RAGN variable area flow meter, herein referred to as RAGN Glass Rotameter, in order to maintain the designed safety level. Items that will be addressed are proof testing, repair and replacement of the flow meter, reliability data, lifetime, environmental and application limits, and parameter settings.

A1.2 Using RAGN for a SIS Application

A1.2.1 Safety Function

Suitable for use in Safety Instrumented Systems are the versions listed in table 1 only. The safety related data listed in this manual does not apply to other versions of RAGN.

Table 1 Versions of RAGN suitable for Safety Instrumented Systems

[V1]	RAGN with Reed-switch(es)
[V2]	RAGN with Ring Initiator, fail-safe state: LOW
[V3]	RAGN with Ring Initiator, fail-safe state: HIGH

This variable area flow meter is intended for use as a volume flow monitoring component in a Safety Instrumented System. It has either inductive ring sensors [V2], [V3] or magnetic reed contacts [V1] to indicate limits. The flow meter may be used with the limit switches to feed signals to a logic solver that is part of the safety instrumented function (SIF) as shown in Figure 1. The fault annunciation mechanism is a trip of one of the limit switches. In order to take credit for the automatic diagnostics in the flow meter, this annunciation mechanism must be connected. Any valve delivered together with RAGN Glass Rotameter is not covered by the assessment.

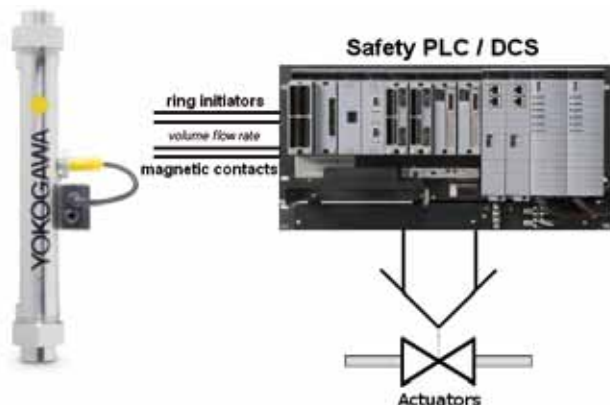

Figure 1 Example Safety Instrumented Function

A1.2.2 Diagnostic Response Time

There is neither diagnostic in the magnetic reed contacts [V1] nor in the inductive ring sensors [V2], [V3].

A1.2.3 Setup

A setup of the flow meter is not required. Installation shall be done according to the manual.

Precautions for use of ring sensors [V2], [V3] in Safety Instrumented Functions:

The high output current should be used as the preferred "safe state." Therefore to achieve highest reliability of the system, the orientation of the ring sensors should be set according to the application to set high current as safe state. For more information on assembly see User's Manual, Model RAGN Glass Rotameter, IM 01R01B10-00E-E.

A1.2.4 Proof Testing

The objective of proof testing is to detect failures within the flow meter. Of main concern are undetected failures that prevent the safety instrumented function from performing its intended function.

The frequency of the proof tests (or the proof test interval) is to be determined in the reliability calculations for the safety instrumented functions for which the flow meter is applied. The actual proof tests must be performed more frequently or as frequently as specified in the calculation in order to maintain required safety integrity of the safety instrumented function.

The following tests need to be specifically executed when a proof test is performed. The results of the proof test need to be documented and this documentation should be part of a plant safety management system. Failures that are detected should be reported to Yokogawa.

Proof test for RAGN Glass Rotameter with magnetic contacts and inductive ring sensors:

Step	Action
1	Take appropriate action to avoid a false trip
2	Inspect the device for any visible damage, corrosion or contamination.
3a	Force the RAGN Glass Rotameter to reach a defined "MAX" threshold value and verify that the magnetic contact or inductive ring initiator goes into the safe state. Note: only applicable if RAGN is equipped with a "MAX" contact.
3b	Force the RAGN Glass Rotameter to reach a defined "MIN" threshold value and verify that the magnetic contact or inductive ring initiator goes into the safe state. Note: only applicable if RAGN is equipped with a "MIN" contact.
4	Restore the loop to full operation
5	Restore normal operation

When all the tests listed above are executed a proof test coverage of approximately 99% of possible DU failures in the RAGN Glass Rotameter can be claimed.

The following tools need to be available to perform proof testing:

Measurement instrument to verify output status of the magnetic reed contacts [V1] or inductive ring sensors [V2], [V3]

The person(s) performing the proof test of the Yokogawa RAGN Glass Rotameter should be trained in SIS operations including bypass procedures, flow meter maintenance and company management of change procedures.

A1.2.5 Repair and replacement

Maintenance information can be found in section Service of the User's Manual, Model RAGN Glass Rotameter, IM 01R01B10-00E-E.

If repair is to be performed with the process online the Rota Yokogawa RAGN Glass Rotameter will need to be bypassed during the repair. The user should setup appropriate bypass procedures for that.

Contact the Yokogawa sales office if this instrument requires repair

The person(s) performing the repair and / or replacement of the Rota Yokogawa RAGN Glass Rotameter should have a sufficient skill level.

A1.2.6 Startup Time

The flow meter will generate a valid signal within 0.5 seconds of power-on startup.

A1.2.7 Reliability data

A detailed Failure Mode, Effects, and Diagnostics Analysis (FMEDA) report is available from Rota Yokogawa with all failure rates and failure modes. Rota Yokogawa RAGN Glass Rotameter is intended for use in a Low Demand Mode. Low Demand Mode means the average interval between dangerous conditions occurs infrequently.

The Rota Yokogawa RAGN Glass Rotameter is certified up to SIL1 for use in a simplex (1oo1) configuration, depending on the PFDAVG calculation of the entire Safety Instrumented Function.

A1.2.8 Lifetime limits

The expected lifetime of the Yokogawa Rota Yokogawa RAGN Glass Rotameter is 10 years. The reliability data listed in A1.2.7 is only valid for this period. The failure rates of the Rota Yokogawa RAGN Glass Rotameter may increase sometime after this period. Reliability calculations based on the data listed in A1.2.7 for Rota Yokogawa RAGN Glass Rotameter lifetimes beyond 10 years may yield results that are too optimistic, i.e. the calculated Safety Integrity Level will not be achieved.

A1.2.9 Environmental limits

The environmental limits of Rota Yokogawa RAGN variable area flow meter are specified in the User's Manual, Model RAGN Glass Rotameter, IM 01R01B10-00E-E.

A1.2.10 Application limits

The application limits of the Rota Yokogawa RAGN variable area flow meter are specified in the User's Manual, Model RAGN Glass Rotameter, IM 01R01B10-00E-E. If the flow meter is used outside of the application limits the reliability data listed in A1.2.7 becomes invalid.

A1.3 Definitions and Abbreviations

A1.3.1 Definitions

Safety	Freedom from unacceptable risk of harm
Functional Safety	The ability of a system to carry out the actions necessary to achieve or to maintain a defined safe state for the equipment / machinery / plant / apparatus under control of the system.
Basic Safety	The equipment must be designed and manufactured such that it protects against risk of damage to persons by electrical shock and other hazards and against resulting fire and explosion. The protection must be effective under all conditions of the nominal operation and under single fault condition.
Verification	The demonstration for each phase of the life-cycle that the (output) deliverables of the phase meet the objectives and requirements specified by the inputs to the phase. The verification is usually executed by analysis and / or testing.
Validation	The demonstration that the safety-related system(s) or the combination of safety-related system(s) and external risk reduction facilities meet, in all respects, the Safety Requirements Specification. The validation is usually executed by testing
Safety Assessment	The investigation to arrive at a judgment - based on evidence - of the safety achieved by safety-related systems

Further definitions of terms used for safety techniques and measures and the description of safety related systems are given in IEC 61508-4.

A1.3.2 Abbreviations

FMEDA	Failure Mode, Effects and Diagnostic Analysis
SIF	Safety Instrumented Function
SIL	Safety Integrity Level
SIS	Safety Instrumented System
SLC	Safety Lifecycle

A1.4 Assessment results

A1.4.1 Safety related parameters

The following results have been obtained from the assessment report Report No.: ROTA YOKOGAWA 11/04-36 R004 Version V1, Revision R1; November 2011 issued by exida.

Average PFD values have been calculated assuming a Diagnostic Coverage (DC) of 99%, a mission time of 10 years and a Mean Time to Restoration of 24 hours.

Table 2: Summary for RAGN – Failure rates

Version	exida Profile 2		
	[V1] Reed contacts	[V2] Fail-safe state LOW	[V3] Fail-safe state HIGH
Fail Safe Detected (λ_{SD})	0 FIT	0 FIT	0 FIT
Fail Safe Undetected (λ_{SU})	20 FIT	2 FIT	11 FIT
Fail Dangerous Detected (λ_{DD})	0 FIT	11 FIT	11 FIT
Fail Dangerous Undetected (λ_{DU})	87 FIT	139 FIT	130 FIT
SFF ³	18%	8%	14%
MTBF	1035 years	738 years	738 years
SIL AC ⁴	SIL1	SIL1	SIL1

Safety metrics according to ISO 13849-1:

MTTFd (years)	1312	761	809
DC ⁵	0%	7%	8%
Category (CAT)	CAT 1	CAT 1	CAT 1
Performance Level (required)	PLr = c	PLr = c	PLr = c
Performance Level (calculated)	8.70E-08 1/h	1.50E-07 1/h	1.41E-07 1/h
PFD _{AVG} , T[Proof] = 1 year	4.12E-04	6.61E-04	6.18E-04
PFD _{AVG} , T[Proof] = 5 years	1.91E-03	3.06E-03	2.86E-03
PFD _{AVG} , T[Proof] = 10 years	3.78E-03	6.07E-03	5.67E-03

³ The complete sensor subsystem will need to be evaluated to determine the overall Safe Failure Fraction. The number listed is for reference only.

⁴ SIL AC (architectural constraints) means that the calculated values are within the range for hardware architectural constraints for the corresponding SIL but does not imply all related IEC 61508 requirements are fulfilled.

⁵ The switching contact output of [V2], [V3] is connected to a fail-safe NAMUR amplifier (e.g. Pepperl+Fuchs KF**-SH-Ex1). The failure rates of the amplifier are not included in the listed failure rates

YOKOGAWA ELECTRIC CORPORATION
World Headquarters
9-32, Nakacho 2-chome, Musashino-shi
Tokyo 180-8750
Japan
www.yokogawa.com

YOKOGAWA CORPORATION OF AMERICA
2 Dart Road
Newnan GA 30265
USA
www.yokogawa.com/us

YOKOGAWA EUROPE B.V.
Euroweg 2
3825 HD AMERSFOORT
The Netherlands
www.yokogawa.com/eu

YOKOGAWA ELECTRIC ASIA Pte. LTD.
5 Bedok South Road
Singapore 469270
Singapore
www.yokogawa.com/sg

YOKOGAWA CHINA CO. LTD.
3F Tower D Cartelo Crocodile Building
No.568 West Tianshan Road Changing District
Shanghai, China
www.yokogawa.com/cn

YOKOGAWA MIDDLE EAST B.S.C.(c)
P.O. Box 10070, Manama
Building 577, Road 2516, Busaiteen 225
Muharraq, Bahrain
www.yokogawa.com/bh

Yokogawa has an extensive sales and distribution network. Please refer to the European website (www.yokogawa.com/eu) to contact your nearest representative.



YOKOGAWA ◆

Rotameter™ is a trademark of Rota Yokogawa GmbH & Co. KG, a subsidiary of Yokogawa Electric Corporation, Japan. In the United Kingdom Rotameter™ is a trademark of Emerson Electric Co.