

Low-frequency, filtered accelerometer

799LF

SPECIFICATIONS

Sensitivity, $\pm 5\%$, 25°C		500 mV/g
Acceleration range		10 g peak
Amplitude nonlinearity		1%
Frequency response:	$\pm 5\%$	0.3 - 1,200 Hz
	$\pm 10\%$	0.2 - 1,600 Hz
	± 3 dB	0.1 - 2,500 Hz
Resonance frequency		18 kHz
Transverse sensitivity, max		5% of axial
Temperature response:	-50°C	-7%
	+120°C	+5%
Power requirement:		
Voltage source		15 - 30 VDC
Current regulating diode		2 - 10 mA
Electrical noise, equiv. g:		
Spectral	0.1 Hz	15 $\mu\text{g}/\sqrt{\text{Hz}}$
	1 Hz	3 $\mu\text{g}/\sqrt{\text{Hz}}$
	10 Hz	1 $\mu\text{g}/\sqrt{\text{Hz}}$
	100 Hz	1 $\mu\text{g}/\sqrt{\text{Hz}}$
Output impedance, max		400 Ω
Bias output voltage		8.0 VDC
Grounding		case isolated, internally shielded
Temperature range		-50° to +120°C
Vibration limit		250 g peak
Shock limit		5,000 g peak
Electromagnetic sensitivity, equiv. g		150 $\mu\text{g}/\text{gauss}$
Sealing		hermetic
Base strain sensitivity, max		0.0005 g/ μstrain
Sensing element design		PZT ceramic / shear
Weight		205 grams
Case material		316L stainless steel
Mounting		1/4-28 tapped hole
Output connector		2 pin, MIL-C-5015 style
Mating connector		R6 type

Accessories supplied: SF6 mounting stud; calibration data (level 3)



Key features

- Ultra low noise
- Optimized for 15 V supply
- Available with M12 connector
- Manufactured in ISO 9001 facility

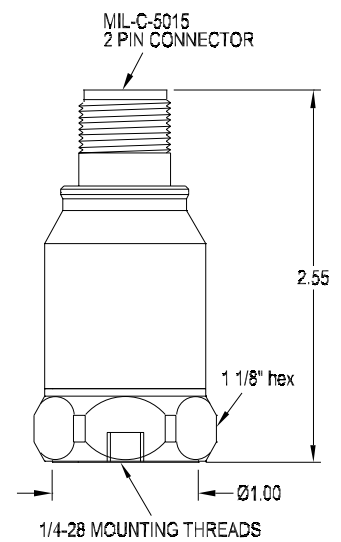

PIN-OUT

Connections	
Function	Connector pin
power/signal	A
common	B
ground	shell



Note: Due to continuous process improvement, specifications are subject to change without notice.
This document is cleared for public release.