

# Class I Div 2 certified accelerometer



## 787A-M8-D2

### SPECIFICATIONS

<b>Sensitivity, <math>\pm 5\%</math>, 25°C</b>		100 mV/g
<b>Acceleration range</b>		80 g peak
<b>Amplitude nonlinearity</b>		1%
<b>Frequency response:</b>	$\pm 10\%$	1.0 - 5,000 Hz
	$\pm 3$ dB	0.5 - 10,000 Hz
<b>Resonance frequency, mounted, min</b>		22 kHz
<b>Transverse sensitivity, max</b>		5% of axial
<b>Temperature response:</b>	-55°C	-20%
	+120°C	+10%
<b>Power requirement:</b>		
Voltage source		18 - 28 VDC
Current regulating diode		2 - 10 mA
<b>Electrical noise, equiv. g, nominal:</b>		
Broadband	2.5 Hz to 25 kHz	700 $\mu$ g
Spectral	10 Hz	10 $\mu$ g/ $\sqrt$ Hz
	100 Hz	5 $\mu$ g/ $\sqrt$ Hz
	1,000 Hz	5 $\mu$ g/ $\sqrt$ Hz
<b>Output impedance, max</b>		100 $\Omega$
<b>Bias output voltage, nominal</b>		12 VDC
<b>Grounding</b>		case isolated, internally shielded
<b>Temperature range</b>		-55° to +120°C
<b>Vibration limit</b>		500 g
<b>Shock limit, min</b>		5,000 g
<b>Electromagnetic sensitivity, equiv. g, max</b>		70 $\mu$ g/gauss
<b>Sealing</b>		hermetic
<b>Base strain sensitivity, max</b>		0.002 g/ $\mu$ strain
<b>Weight</b>		145 grams
<b>Case material</b>		316L stainless steel
<b>Mounting</b>		M8 captive hex head screw with 0.046" diameter safety wire hole
<b>Output connector</b>		2 pin, MIL-C-5015 style
<b>Mating connector</b>		R6D2
<b>Recommended cabling</b>		J10 / J9T2A, no more than 100 ft.

Accessories supplied: SCM8125 captive hex head screw; calibration data

### Certifications

	Class I, Div 2 Groups A, B, C, D		II 3 G	
	Class I, Zone 2		Ex nA IIC T4 Gc	
	AEx/Ex nA II T4			
	Tamb: -50°C to 120°C			
<small>Must be installed per 13029. • Ambient temperature range depends on the type cable used during installation. • Cable with FEP jacket, Ta=-50°C to +120°C. • Cable with Santoprene jacket, Ta=-45°C to +115°C.</small>				



### Key features

- Certified for use in Class I, Div 2 / Zone 2 hazardous areas
- API 670 compliant
- Manufactured in ISO 9001 facility

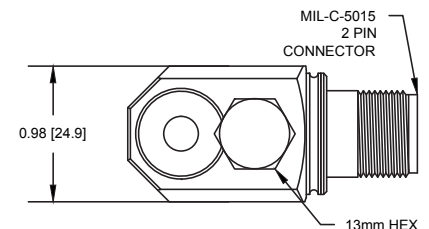
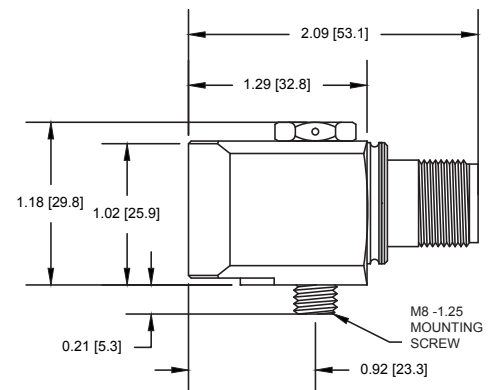

Connections	
Function	Connector pin
power/signal	A
common	B
ground	shell

Note: Due to continuous process improvement, specifications are subject to change without notice. This document is cleared for public release.