

EZ-ZONE® RUI/Gateway

User's Guide

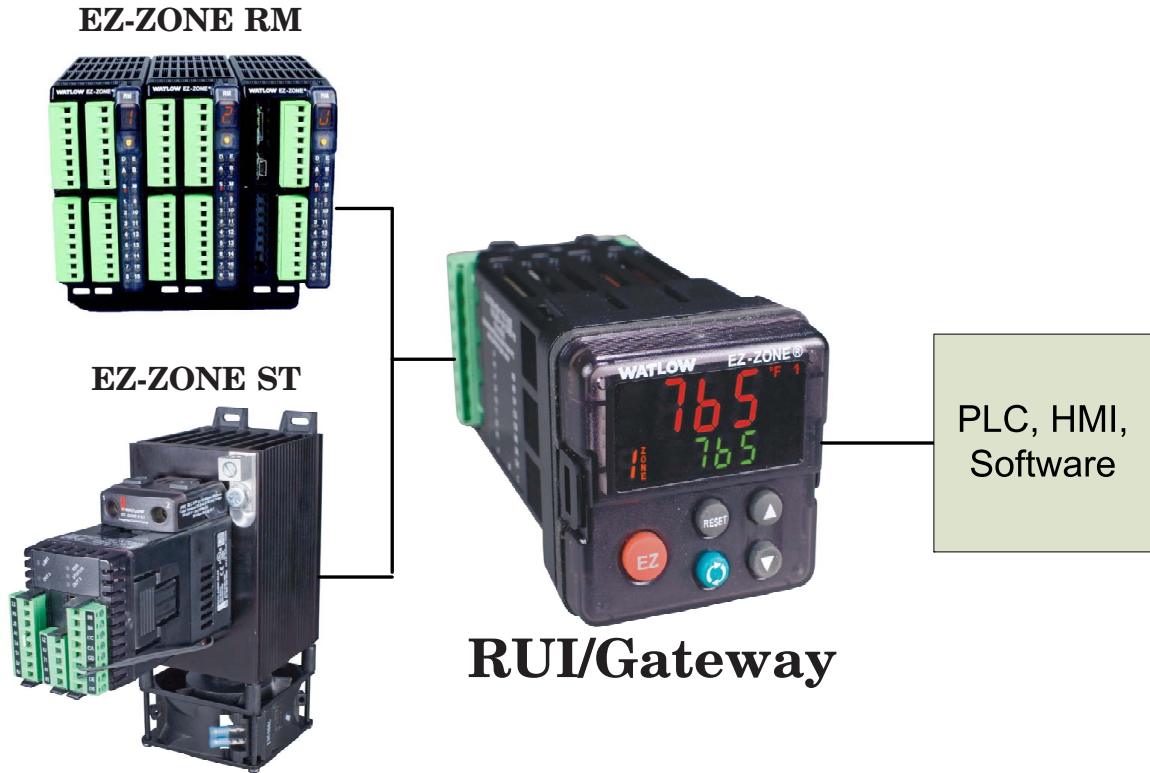

1241 Bundy Boulevard., Winona, Minnesota USA 55987
Phone: +1 (507) 454-5300, Fax: +1 (507) 452-4507 <http://www.watlow.com>

**TOTAL
CUSTOMER
SATISFACTION**

3 Year Warranty

ISO 9001



Registered Company
Winona, Minnesota USA



Safety Information









We use note, caution and warning symbols throughout this book to draw your attention to important operational and safety information.





A “NOTE” marks a short message to alert you to an important detail.

A “CAUTION” safety alert appears with information that is important for protecting your equipment and performance. Be especially careful to read and follow all cautions that apply to your application.

A “WARNING” safety alert appears with information that is important for protecting you, others and equipment from damage. Pay very close attention to all warnings that apply to your application.

The electrical hazard symbol, ⚡ (a lightning bolt in a triangle) precedes an electric shock hazard CAUTION or WARNING safety statement.

Symbol	Explanation
	CAUTION – Warning or Hazard that needs further explanation than label on unit can provide. Consult User's Guide for further information.
	ESD Sensitive product, use proper grounding and handling techniques when installing or servicing product.
	Unit protected by double/reinforced insulation for shock hazard prevention.
	Do not throw in trash, use proper recycling techniques or consult manufacturer for proper disposal.
	Enclosure made of Polycarbonate material. Use proper recycling techniques or consult manufacturer for proper disposal.
	Unit can be powered with either alternating current (ac) voltage or direct current (dc) voltage.
	Unit is a Listed device per Underwriters Laboratories®. It has been evaluated to United States and Canadian requirements for Process Control Equipment. UL 61010 and CSA C22.2 No. 61010. File E185611 QUXX, QUXX7. See: www.ul.com
	Unit is a Listed device per Underwriters Laboratories®. It has been evaluated to United States and Canadian requirements for industrial control equipment UL 508 CSA C22.2 #14 File E102269 NKCR, NKCR7. See: www.ul.com

	Unit is compliant with European Union directives. See Declaration of Conformity for further details on Directives and Standards used for Compliance.
	Unit has been reviewed and approved by CSA International for use as Temperature Indicating-Regulating Equipment per CSA C22.2 No. 24 or C22.2 #14. See: www.csa-international.org
	Unit has been reviewed and approved by ODVA for compliance with DeviceNet communications protocol. See: www.odva.org
	Unit has been reviewed and approved by ODVA for compliance with Ethernet/IP communications protocol. See: www.odva.org

Warranty

The EZ-ZONE® RUI/Gateway is manufactured by ISO 9001-registered processes and is backed by a three-year warranty to the first purchaser for use, providing that the units have not been misapplied. Since Watlow has no control over their use, and sometimes misuse, we cannot guarantee against failure. Watlow's obligations hereunder, at Watlow's option, are limited to replacement, repair or refund of purchase price, and parts which upon examination prove to be defective within the warranty period specified. This warranty does not apply to damage resulting from transportation, alteration, misuse or abuse. The purchaser must use Watlow parts to maintain all listed ratings.

Technical Assistance

If you encounter a problem with your Watlow controller, review your configuration information to verify that your selections are consistent with your application: inputs, outputs, alarms, limits, etc. If the problem persists, you can get technical assistance from your local Watlow representative (see back cover), by e-mailing your questions to wintechsupport@watlow.com or by dialing +1 (507) 494-5656 between 7 a.m. and 5 p.m., Central Standard Time (CST). Ask for for an Applications Engineer. Please have the following information available when calling:

- Complete model number

Return Material Authorization (RMA)

1. Call Watlow Customer Service, (507) 454-5300, for a Return Material Authorization (RMA) number before returning any item for repair. If you do not know why the product failed, contact an Application Engineer or Product Manager. All RMA's require:

- Ship-to address
- Bill-to address
- Contact name
- Phone number
- Method of return shipment

- Your P.O. number
 - Detailed description of the problem
 - Any special instructions
 - Name and phone number of person returning the product.
2. Prior approval and an RMA number from the Customer Service Department is required when returning any product for credit, repair or evaluation. Make sure the RMA number is on the outside of the carton and on all paperwork returned. Ship on a Freight Prepaid basis.
 3. After we receive your return, we will examine it and try to verify the reason for returning it.
 4. In cases of manufacturing defect, we will enter a repair order, replacement order or issue credit for material returned. In cases of customer mis-use, we will provide repair costs and request a purchase order to proceed with the repair work.
 5. To return products that are not defective, goods must be in new condition, in the original boxes and they must be returned within 120 days of receipt. A 20 percent restocking charge is applied for all returned stock controls and accessories.
 6. If the unit is not repairable, you will receive a letter of explanation and be given the option to have the unit returned to you at your expense or to have us scrap the unit.
 7. Watlow reserves the right to charge for no trouble found (NTF) returns.

The EZ-ZONE® Remote User's Interface User's Guide is copyrighted by Watlow Winona, Inc., © March 2012 with all rights reserved.

Table of Contents

Chapter 1: Overview	3
Features and Benefits	3
RUI/GTW Panel Cutout Dimensions	4
Chapter 2: Install, Wire and Set Address	4
Mounting the Remote User Interface (RUI)	5
Standard Bus EIA-485 Communications	6
EIA-232/485 Modbus RTU Communications	6
EtherNet/IP™ and Modbus TCP Communications	7
DeviceNet™ Communications	7
Profibus DP Communications	7
Wiring a Serial EIA-485 Network	8
Responding to a Displayed Message	10
Chapter 3: Keys and Displays	10
Programming the EZ Key Using an RUI	13
Using the RUI with PM Family Controllers	13
Using the RUI with RM Family Controllers	13
Using the RUI with ST Family Controllers	13
Default Home Pages	15
EZ-ZONE PM Express Home Page	16
EZ-ZONE ST Home Page	17
EZ-ZONE PM Home Page	18
EZ-ZONE RMC (Controller) Home Page	19
EZ-ZONE RME (Expansion) Home Page	19
EZ-ZONE RMS (Scanner) Home Page	19
EZ-ZONE RMH (High Density) Home Page	19
EZ-ZONE RMH (High Density) Home Page (cont.)	20
EZ-ZONE RML (Limit) Home Page	20
Chapter 4: RUI Page	21
Communications Menu	22
Global Menu	25
Gateway Menu	25
Security Setting Menu	26
Unlock Security Setting Menu	27
Diagnostics Menu	27

Table of Contents (cont.)

Chapter 5: Using an RUI/Gateway	29
Conceptual View of the RUI/GTW.	29
Using RUI Lockout and Password Security	29
Using Lockout Method 1 (Read and Set Lock)	29
Using Lockout Method 2 (Password Enable)	30
Using Modbus RTU	31
CIP - Communications Capabilities	32
Using DeviceNet™	33
DeviceNet RUI/GTW LED Indicators	34
Using EtherNet/IP™	35
Using Modbus TCP	36
Ethernet RUI/GTW LED Indicators	36
Using Profibus DP	37
Profibus DP RUI/GTW LED Indicators	38
Software Configuration	39
Saving Settings to Non-volatile Memory	42
Chapter 6: Appendix	43
Troubleshooting	43
Modbus - Programmable Memory Blocks	44
PM Modbus Assembly Definition	44
RM Modbus Assembly Definition	46
CIP Implicit Assemblies	49
ST CIP Implicit Assemblies	49
PM CIP Implicit Assemblies	50
RME CIP Implicit Assemblies	51
RMC CIP Implicit Assemblies	52
RMH, RMS and RML CIP Implicit Assemblies	54
Specifications	56
Ordering Information	57
How to Reach Us	59

1

Chapter 1: Overview

Features and Benefits

Remote User Interface/Gateway (RUI/GTW)

- Uses one RUI for multiple zones
- The RUI without a gateway card utilizes minimal panel depth allowing it to fit in small spaces
- Eliminates the costs and complexity of having to bring all controller related wires to the front panel
- Enables the use of multiple RUIs to improve the system's usability and flexibility

Agency approvals: UL Listed, cULus, CSA, CE, RoHS,

- Assures prompt product acceptance
- Reduces end product documentation costs

Short Case

- CSA C22.2 #14 Approved File 158031
- cULus UL 508 Listed approval File E102269
- UL® 50 Type 4X, NEMA 4X indoor locations, IP65 front panel seal (indoor use only)

Long Case

- UL® Listed to UL 61010-1 File E185611
- UL® Reviewed to CSA C22.2 No.61010-1-04
- UL® 50 Type 4X, NEMA 4X indoor locations, IP66 front panel seal (indoor use only)
- ODVA-EtherNet/IP™ and DeviceNet Compliance
- CSA C22.2 No. 24 File 158031 Class 4813-02
- Profibus DP

P3T Armor Sealing System

- NEMA 4X and IP65, indoor use only
- Offers water and dust resistance, can be cleaned and washed down

Three-year warranty

- Demonstrates Watlow's reliability and product support

EZ-Key

- Programmable EZ-Key enables simple one-touch operation of repetitive user activities

Using the RUI/GTW as a Gateway

The addition of a gateway card allows information to be passed from the Standard Bus side of the gateway (EZ-ZONE®-family controllers) to one or more of the following popular field bus networks:

- EtherNet/IP™
- DeviceNet™
- Modbus TCP
- Modbus RTU
- Profibus DP

The networks see the gateway and RUI as separate devices. Both sides (1 port on each side) of the gateway will require unique addresses based on the protocol specifications.

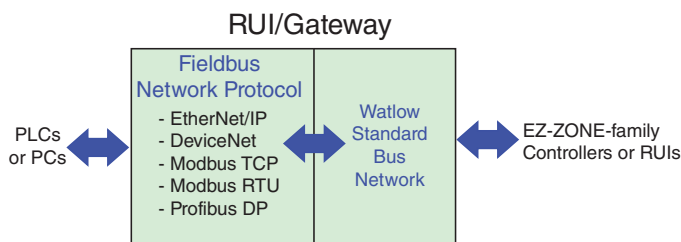

Note:

Excessive writes through the gateway to other EZ-ZONE® family controllers may cause premature EE-PROM failure. For more detail see the section entitled “[Saving Settings to Nonvolatile Memory.](#)”

Note:

A Standard Bus network can communicate with a maximum of eight RUIs with up to four of those being gateways. Valid Standard Bus addresses for RUIs equipped with the gateway option are 1, 2, 3 or 4. As is always the case each RUI must have a unique Standard Bus address.

2

Chapter 2: Install, Wire and Set Address

RUI/GTW Panel Cutout Dimensions

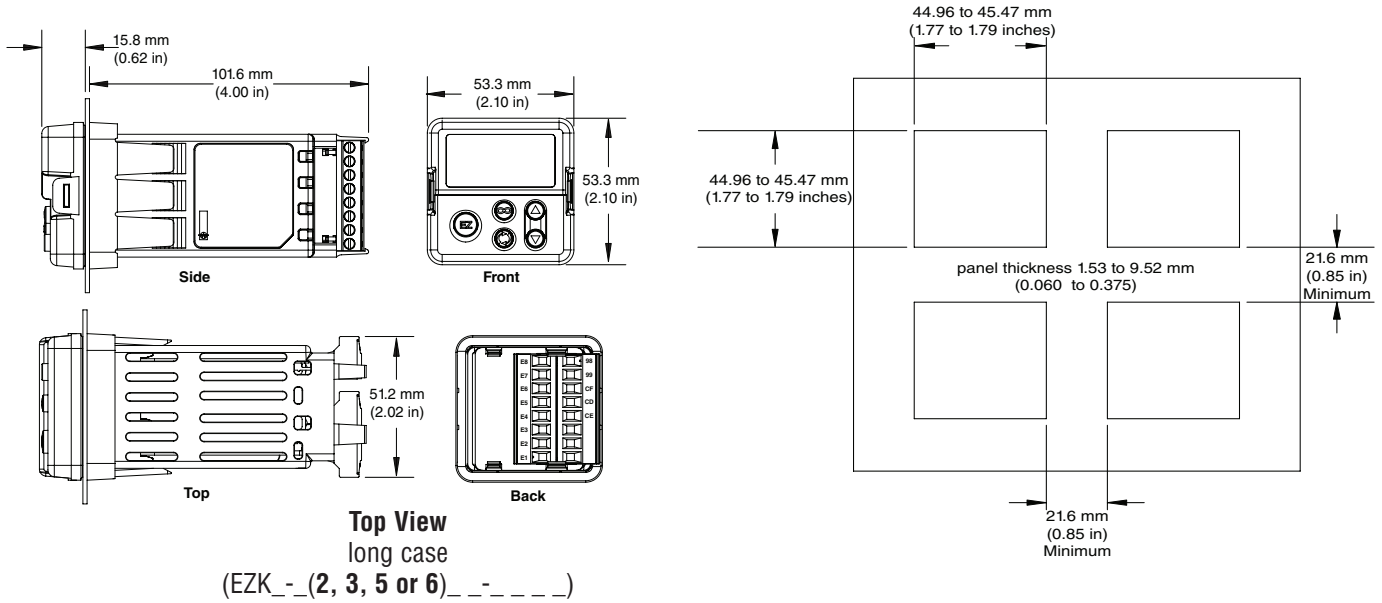

Back View
short case

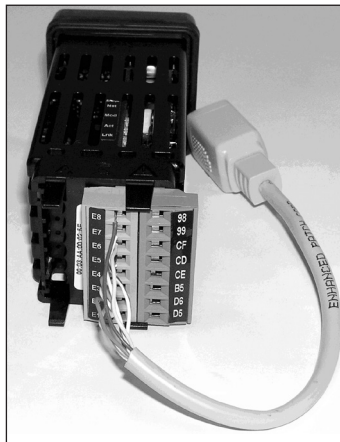
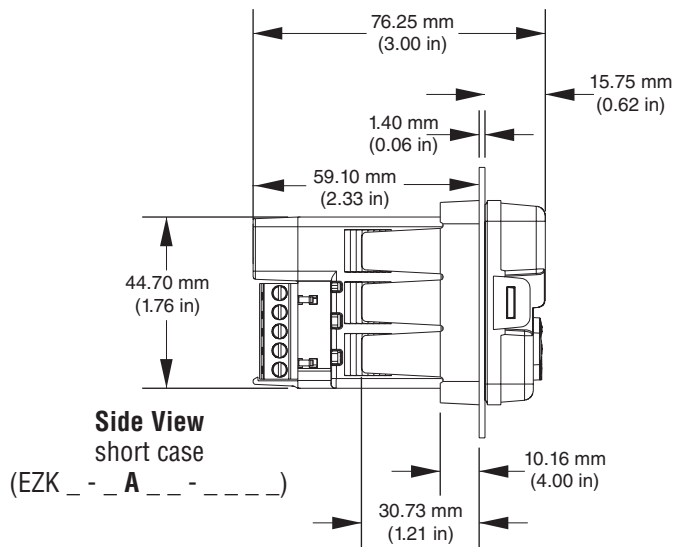

EtherNet/IP™ and Modbus TCP gateway in slot B. Shown with supplied cable.



Mounting the Remote User Interface (RUI)

1. Make the panel cutout using the mounting template dimensions in this chapter. Insert the case assembly into the panel cutout.

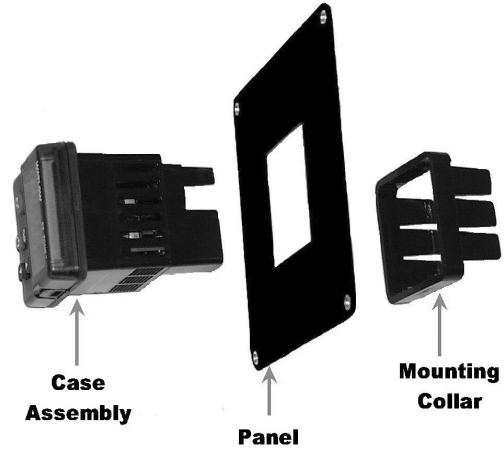

2. While pressing the case assembly firmly against the panel, slide the mounting collar over the back of the RUI. If the installation does not require an IP66/NEMA 4X seal, slide the mounting collar up to the back of the panel tight enough to eliminate the spacing between the gasket and the panel.

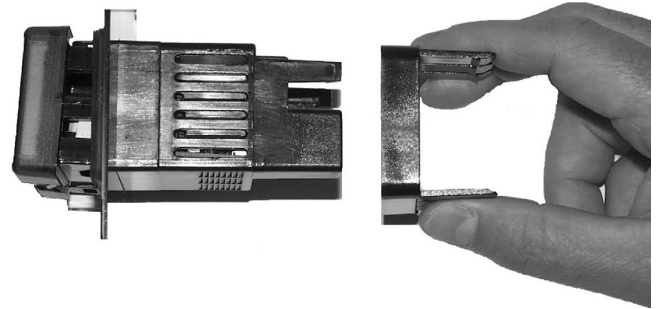

3. For an IP66/NEMA 4X seal, place the blade of a screwdriver in the notch of the mounting collar assembly and push to ward the panel while applying pressure to the face of the RUI. Don't be afraid to apply enough pressure to properly install the RUI. If you can move the case assembly back and forth in the cutout, you do not have a proper seal. The tabs on each side of the bracket have teeth that latch into the ridges. Each tooth is staggered at a different depth from the front so that only one of the tabs on each side is locked onto the ridges at a time. The seal is good if the distance from the panel and the top half of the assembly is 16 mm (0.630 in.) or less, and the distance bottom half and the panel is 13.3 mm (0.525 in.) or less

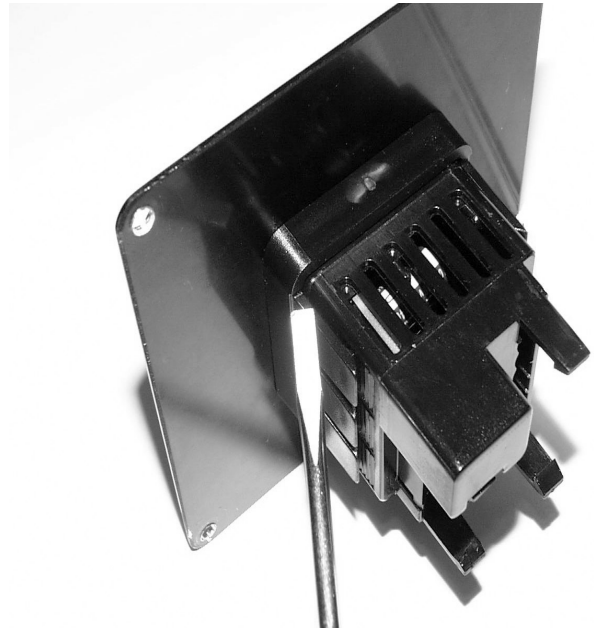



Warning:
 Use National Electric (NEC) or other country-specific standard wiring and safety practices when wiring and connecting this controller to a power source and to electrical sensors or peripheral devices. Failure to do so may result in damage to equipment and property, and/or injury or loss of life.

Power

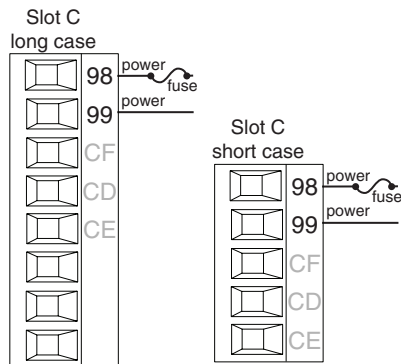

- Minimum/Maximum Ratings
- 85 to 264V~ (ac)
- 20.4 to 26.4 V \approx (ac/dc)
- 47 to 63Hz
- 6VA maximum

Standard Bus EIA-485 Communications

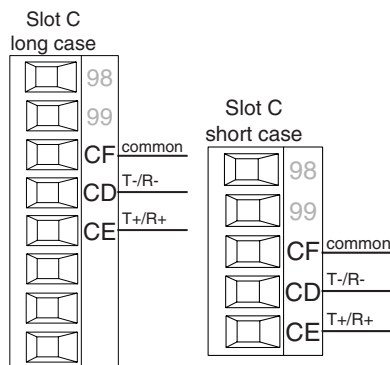

- Wire T-/R- to the A terminal of the EIA-485 port.
- Wire T+/R+ to the B terminal of the EIA-485 port.
- Wire common to the common terminal of the EIA-485 port.
- Do not route network wires with power wires. Connect network wires in daisy-chain fashion when connecting multiple devices in a network.
- Do not connect more than 16 controllers on a network.
- maximum network length: 1,200 meters (4,000 feet)
- 1/8th unit load on EIA-485 bus

Note:

Disconnect any USB to EIA-485 converter when not connected to a PC (without power). Failure to do so may cause communications errors.

EIA-232/485 Modbus RTU Communications

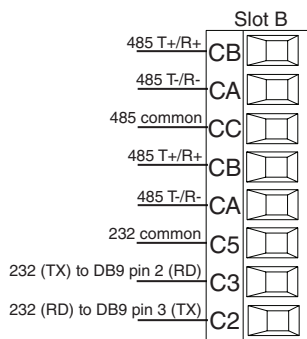

- Wire T-/R- to the A terminal of the EIA-485 port.
- Wire T+/R+ to the B terminal of the EIA-485 port.
- Wire common to the common terminal of the EIA-485 port.
- Do not route network wires with power wires. Connect network wires in daisy-chain fashion when connecting multiple devices in a network.
- A termination resistor may be required. Place a 120 Ω resistor across T+/R+ and T-/R- of last controller on network.
- Do not wire to both the EIA-485 and the EIA-232 pins at

the same time.

- Two EIA-485 terminals of T/R are provided to assist in daisy-chain wiring.
- Do not connect more than one EZ-ZONE[®] RUI on a EIA-232 network.
- Maximum number of EZ-ZONE[®] RUI on a Modbus[®] RTU EIA-485 network: 247
- Maximum EIA-232 network length: 15 meters (50 feet)
- Maximum EIA-485 network length: 1,200 meters (4,000 feet)
- 1/8th unit load on EIA-485 bus.

EZK _ _ 2 _ _ -A _ A A

Note:

Disconnect any USB to EIA-485 converter when not connected to a PC (without power). Failure to do so may cause communications errors.

Modbus-IDA Terminal	EIA/TIA-485 Name	Watlow Terminal Label	Function
DO	A	CA or CD	T-/R-
D1	B	CB or CE	T+/R+
common	common	CC or CF	common



Warning:

Use National Electric (NEC) or other country-specific standard wiring and safety practices when wiring and connecting this controller to a power source and to electrical sensors or peripheral devices. Failure to do so may result in damage to equipment and property, and/or injury or loss of life.

EtherNet/IP™ and Modbus TCP Communications

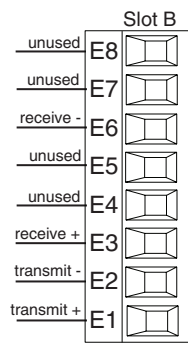

RJ-45 pin	T568B wire color	Signal	Slot B
8	brown	unused	E8
7	brown & white	unused	E7
6	green	receive -	E6
5	white & blue	unused	E5
4	blue	unused	E4
3	white & green	receive +	E3
2	orange	transmit -	E2
1	white & orange	transmit +	E1

- Do not route network wires with power wires.
- Connect one Ethernet cable per device to a 10/100 mbps Ethernet switch. Both Modbus® TCP and EtherNet/IP™ are available on the network.

Note:

When changing the fixed IP address on the RUI cycle module power for new address to take effect.

DeviceNet™ Communications

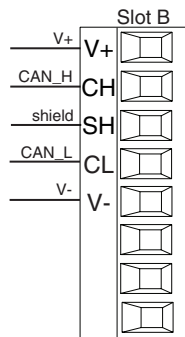

Terminal	Signal	Function
V+	V+	DeviceNet™ power
CH	CAN_H	positive side of DeviceNet™ bus
SH	shield	shield interconnect
CL	CAN_L	negative side of DeviceNet™ bus
V-	V-	DeviceNet™ power return

Profibus DP Communications

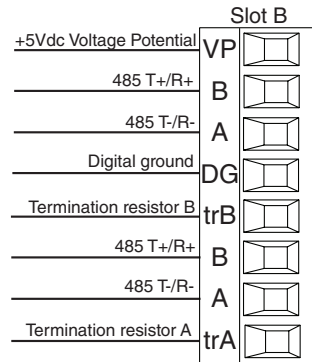

- Wire T-/R- to the A terminal of the EIA-485 port.
- Wire T+/R+ to the B terminal of the EIA-485 port.
- Wire Digital Ground to the common terminal of the EIA-485 port.
- Do not route network wires with power wires. Connect network wires in daisy-chain fashion when connecting multiple devices in a network.
- A termination resistor should be used if this controller is the last one on the network.
- If using a 150 Ω cable Watlow provides internal termination. Place a jumper across pins trB and B and trA and A.
- If external termination is to be used with a 150 Ω cable place a 390 Ω resistor across pins VP and B, a 220 Ω resistor across pins B and A, and lastly, place a 390 Ω resistor across pins DG and A.
- Do not connect more than 32 EZ-ZONE devices on any given segment.
- Maximum EIA-485 network length: 1,200 meters (4,000 feet)
- 1/8th unit load on EIA-485 bus.



Warning:
Use National Electric (NEC) or other country-specific standard wiring and safety practices when wiring and connecting this controller to a power source and to electrical sensors or peripheral devices. Failure to do so may result in damage to equipment and property, and/or injury or loss of life.

Note:
Excessive writes through the gateway to other EZ-ZONE family controllers may cause premature EEPROM failure. For more detail see the section entitled "Saving Settings to Non-volatile Memory."

Wiring a Serial EIA-485 Network

Do not route network wires with power wires. Connect network wires in daisy-chain fashion when connecting multiple devices in a network.

A termination resistor may be required. Place a 120 Ω resistor across T+/R+ and T-/R- of the last controller on a network.

An RUI/Gateway allows for connectivity between dissimilar networks. In this case, Ethernet on one side and Standard Bus on the other.

Note:

The RUI without a gateway installed, can communicate using Watlows' Standard Bus only.

Note:

Do not route network wires with power wires.

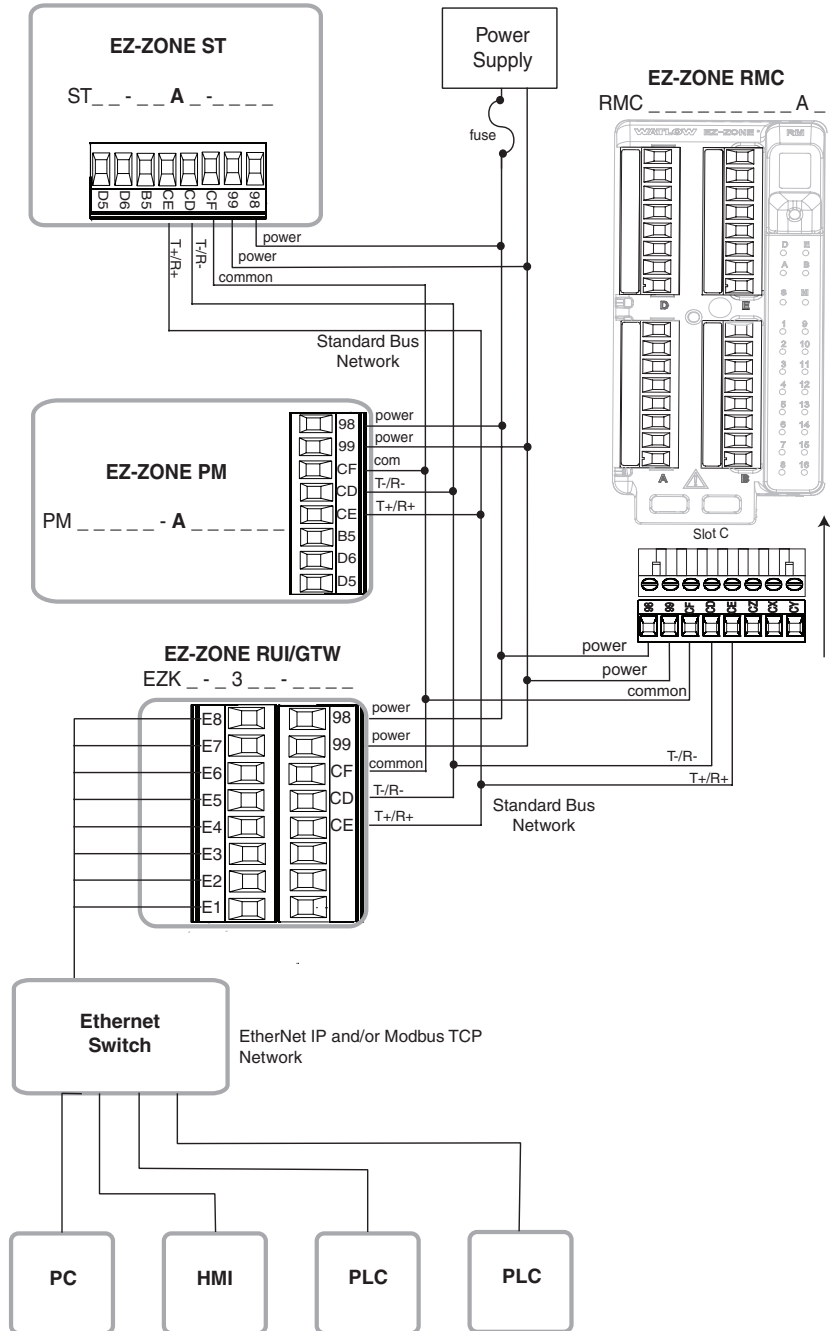



Warning:

Use National Electric (NEC) or other country-specific standard wiring and safety practices when wiring and connecting this controller to a power source and to electrical sensors or peripheral devices. Failure to do so may result in damage to equipment and property, and/or injury or loss of life.

A network using Watlow's Standard Bus and an RUI

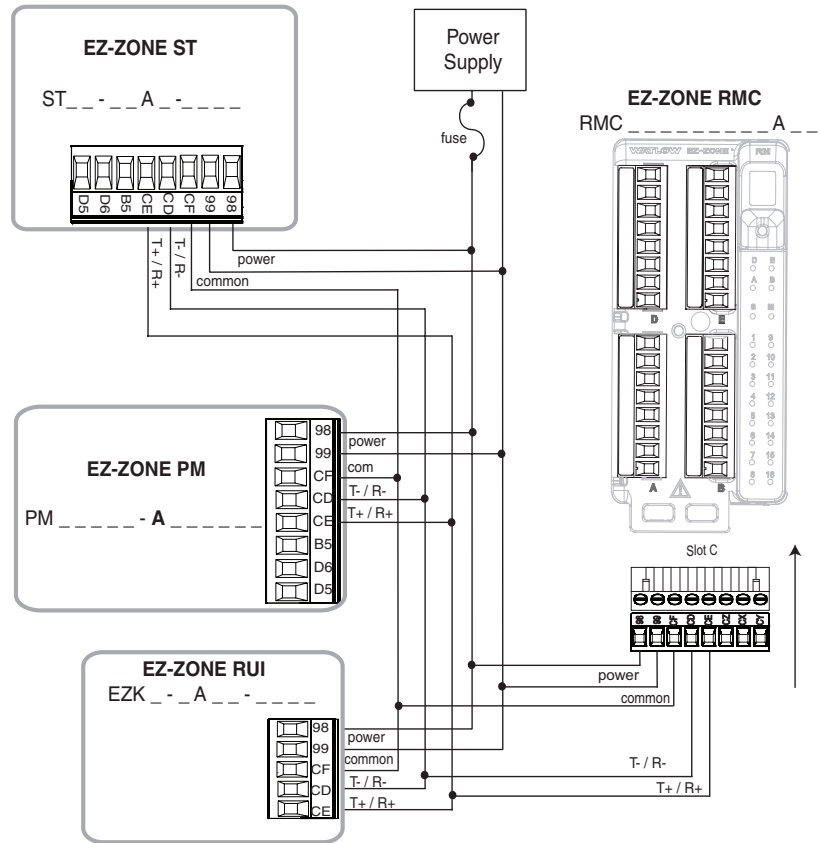

3

Chapter 3: Keys and Displays

Upper Display:

In the Home Page, displays the parameter specified by Custom 1 in the factory page, otherwise displays the value of the parameter in the lower display.

Zone Display:

Indicates the controller zone that the RUI is currently communicating with.

A = zone 10	E = zone 14
b = zone 11	F = zone 15
C = zone 12	h = zone 16
d = zone 13	J = zone 17

Lower Display:

Indicates the set point or output power value during operation, or the parameter whose value appears in the upper display.

EZ Key:

This key can be programmed to do various tasks, such as starting a profile.

Note:

Upon power up, the upper or left display will briefly indicate the firmware revision and the lower or right display will show RUI.



Temperature Units:

Indicates whether the temperature is displayed in Fahrenheit or Celsius.

Output Activity:

Number LEDs indicate activity of outputs. A flashing light indicates output activity.

Percent Units:

Lights when the controller is displaying values as a percentage or when the open-loop set point is displayed.

Profile Activity;

Lights when a profile is running. Flashes when a profile is paused.

Communications Activity

Flashes when another device is communicating with the RUI.

Up and Down Keys ▲ ▼

In the Home Page, the parameter specified by Custom 1 in the factory page. In other pages, changes the upper display to a higher or lower value, or changes a parameter selection.

Infinity Key ∞

In the Home Page, press to scroll through the network zones, clears alarms and errors if clearable.

On other pages, press to back up one level, or press and hold for two seconds to return to the Home Page.

Advance Key ⌂

Advances through parameter prompts.





Responding to a Displayed Message

Attention Codes

An active message will cause the display to toggle between the normal settings and the active message in the upper display and Attention [ALERT] in the lower display.

Your response will depend on the message and the controller settings. Some messages, such as Ramping and Tuning, indicate that a process is underway. If the message was generated by a latched alarm or limit condition, the message can be cleared when the condition no longer exists by simply pushing the Infinity ∞ key or alternatively, by following the steps below. If an alarm has silencing enabled, it can also be silenced.

Push the Advance Key ⌂ to display Ignore [IGNR] in the upper display and the message source, such as Limit High [L.H.I] in the lower display. Use the Up ▲ and Down ▼ keys to scroll through possible responses, such as Clear [CLR] or Silence [SIL], then push the Advance ⌂ or Infinity ∞ key to execute the action. See the table below for further information on the Attention Codes.

Display	Parameter Name Description	Setting	Range	Default	Appears If
ALEn	<p>Attention An active message will cause the display to toggle between the normal settings and the active message instance in the upper display, ALEn in the lower display, and the Zone will flash reflecting the Zone which generated the message.</p> <p>Your response will depend on the message and the controller settings. Some messages, such as Ramping and Tuning, indicate that a process is underway. If the message was generated by a latched alarm or limit condition, the message can be cleared when the condition no longer exists. If an alarm has silencing enabled, it can be silenced.</p> <p>Push the Advance Key  to display ALEn in the upper display and the message source (such as Lh1) in the lower display.</p> <p>Use the Up  and Down  keys to scroll through possible responses, such as Clear CLR or Silence SIL. Then push the Advance  or Infinity  key to execute the action.</p>		<p>Note: Due to the fact that the RUI/GTW can be used with all EZ-ZONE controllers, the prompts and the number of instances shown below reflect features and the maximum values that could be available across the family of controllers at the time this manual was written. <i>The maximum values shown are subject to change in the future.</i> To determine the features and the maximum number of instances available for your controller please reference the associated product user manual.</p> <p>ALL1 to ALL8 Alarm Low 1 to 24 ALh1 to ALh8 Alarm High 1 to 24 ALe1 to ALe8 Alarm Error 1 to 24 Er.1 to Er.16 Error Input 1 to 16 L.L1 to L.L4 Limit Low 1 to 16 L.h1 to L.h4 Limit High 1 to 16 L.e1 to L.e4 Limit Error 1 to 16 tUn1 to tUn9 Tuning 1 to 9 tU10 to tU16 Tuning 10 to 16 rP1 to rP16 Ramping 1 to 16 LPo1 to LP16 Loop Open Error 1 to 16 LP.r1 to LP.16 Loop Reversed Error 1 to 16 CEr1 to CEr4 Current Error hEr1 to hEr4 Heater Error uALh Value too large to be displayed (≥ 10000.0) uALL Value too small to be displayed (≤ -2000.0)</p>		an alarm or error message is active.
PSE1	<p>Profile Start Select a profile or step number that will be affected by Profile Action.</p>		<p>Note: Due to the fact that the RUI/GTW can be used with all EZ-ZONE controllers, the prompts and the number of instances shown below reflect features and the maximum values that could be available across the family of controllers at the time this manual was written. <i>The maximum values shown are subject to change in the future.</i> To determine the features and the maximum number of instances available for your controller please reference the associated product user manual.</p> <p>0 to 250</p>	0	the controller includes profiling.
PAC1	<p>Profile Action Request Select the action to apply to the profile or step selected in Profile Start.</p>		<p>nonE No Action ProF Start a Profile PAUS Pause rESU Resume End End</p>	None	the controller includes profiling









No Device Connected

If there is no device connected to the RUI/GTW or the controller on the selected zone is disconnected, **no** will appear in the upper display and **dEw** will appear in the lower display. Press the Infinity Key  to move to the next zone.

If a zone disappears, ensure that its Standard Bus address was not intentionally changed. Also, check all network wiring and ensure that communications wiring is routed separately from power wiring.

Changing the Position of a Controllers Operations Page and or Profiling Page in the Lockout Menu

To change the position of the Operations Page or Profiling Page in the Lockout Menu, you must go to the Lock Operations Page parameter `[LoCo]` or Lock Profiling Page parameter `[LoCP]` in the Lockout Menu in the Factory Page.

- To go to the Factory Page from the Home Page, press both the Advance  and Infinity  keys for six seconds. `[CuSE]` will appear in the Upper Display and `[FLTY]` will appear in the Lower Display.
- Press the Up  or Down  key to move to the Lockout Menu `[LoC]`.
- Press the Advance Key  to select a parameter.
- Press the Up  or Down  key to change the parameter value. The value you select (1, 2 or 3) will determine the position of the Operations Page or Profiling Pages in the Lockout Menu in the RUI Page.
- Press the Infinity Key  to move backwards through the levels: parameter to menu; menu to Home Page.
- Press and hold the Infinity Key  for two seconds to return to the Home Page.

Note:

`[rLoC]` and `[SLoC]` settings of the RUI will always take precedence over any other individual controller settings. In other words, if an RUI is on a network with multiple PM controllers where all of the PM controllers have `[SLoC]` set to 0 (not writable) and the RUI has `[SLoC]` set to 5, all writable parameters in all PM controllers can be written to via the RUI. Conversely, if all PM controllers have `[SLoC]` set to 5 and the RUI has it set to 0 all of the PM controllers will be write protected. If it is required that protection for any given controller not be overridden by the RUI turn to the Features section of the controller user manual and find the section entitled "Using Password Security".

Example 1

The operator wants to read all the menus and not allow any parameters to be changed.

In the RUI Page, Lockout Menu, set Read Lock `[rLoC]` to 5 and Set Lock `[SLoC]` to 0.

Example 2

The operator wants to read and write to the Home Page and Profiling Page, and lock all other pages and menus.

In the RUI Page, Lockout Menu, set Read Lock `[rLoC]` to 2 and Set Lock `[SLoC]` to 2.

In the Factory Page, Lockout Menu, set Lock Operations Page `[LoCo]` to 3 and Lock Profiling Page `[LoCP]` to 2.

Example 3

The operator wants to read the Operations Page, Setup Page, Profiling Page, Diagnostics Menu, Lock Menu, Calibration Menu and Custom Menus. The operator also wants to read and write to the Home Page.

In the RUI Page, Lockout Menu, set Read Lock `[rLoC]` to 1 and Set Lock `[SLoC]` to 5.

In the Factory Page, Lockout Menu, set Lock Operations Page `[LoCo]` to 2 and Lock Profiling Page `[LoCP]` to 3.

Programming the EZ Key Using an RUI

The following examples show how to program the EZ Key to start and stop a profile using PM, RM and ST family controllers.

Note:

This functionality is embedded in the configuration of the control, therefore, any "EZ" Function Key from any RUI pointing to the programmed control will assume the programmed function.

Using the RUI with PM Family Controllers

Note:

The steps shown below were created using PM firmware version 11.00. Slight differences may exist if your controller has a different version. The firmware version can be found by cycling power to the controller (first numerical value displayed in the upper display) or by navigating to the revision **[rEu]** prompt found in the Diagnostic Menu **[d,19]** in the Factory Page

1. Go to the Setup Page from the Home Page, press both the Up **[▲]** and Down **[▼]** keys for six seconds. **[R,]** will appear in the upper display and **[SEt]** will appear in the lower display.
2. Press the Up **[▲]** or Down **[▼]** key until **[FUN]** appears in the upper display and **[SEt]** will appear in the lower display.
3. Press the Advance Key **[⊕]** once. **[h,9h]** will appear in the upper display and **[LEu]** (high or low) will appear in the lower display. Select whether a high state or a low state will start the profile.
3. Press the Up **[▲]** or Down **[▼]** key to scroll through the functions that can be assigned to the EZ Key. When **[P,SEt]** (Profile Start/Stop) appears in the upper display and **[Fn]** appears in the lower display, press the Infinity Key once to select that function and move to the **[F,]** (Function Instance equals Profile 1, 2, 3 or 4) parameter.
4. Press the Up **[▲]** or Down **[▼]** key to select the profile of choice.
5. Press the Infinity Key **[∞]** once to return to the sub-menu, twice to return to the Home Page.

Using the RUI with RM Family Controllers

Note:

The steps shown below were created using RM firmware version 6.00. Slight differences may exist if your controller has a different version. The firmware version can be found by navigating to the revision **[rEu]** prompt found in the Diagnostic Menu **[d,19]** in the Factory Page.

1. Go to the Setup Page from the Home Page, press both the Up **[▲]** and Down **[▼]** keys for six seconds. **[R,]** will appear in the upper display and **[SEt]** will appear in the lower display.

2. Press the Up **[▲]** or Down **[▼]** key until the Action prompt **[ACT]** appears in the upper display and **[SEt]** will appear in the lower display.
3. Press the Advance Key **[⊕]** once and select the Action instance (1-8) using the Up **[▲]** or Down **[▼]** key. Upon entry, the upper display will show **[]** and the lower display will show **[ACT]**.
4. Press the Advance Key **[⊕]** once and then using the Up **[▲]** or Down **[▼]** key to select Profile Start/Stop **[P,SEt]** as the Function **[Fn]**.
5. Press the Advance Key **[⊕]** once and then using the Up **[▲]** or Down **[▼]** key select the Function Instance **[F,]** (Function Instance equals Profile 1, 2, 3...25).
6. Press the Advance Key **[⊕]** once to define the source of this Action by using the Up **[▲]** or Down **[▼]** key to select the Function Key **[Fun]** as the Source Function **[SF,]**.
7. Press the Advance Key **[⊕]** once and then using the Up **[▲]** or Down **[▼]** key select the Source Instance **[S,]** (Source Instance in this case equals EZ-Key 1 or 2).
8. Press the Advance Key **[⊕]** once and then using the Up **[▲]** or Down **[▼]** key select the Source Zone **[SZ,]** (Source Zone equals 0 -16).

Note:

Zone 0 represents the current module being configured while in this example, this selection represents the module in which the profile will run.

9. Press the Advance Key **[⊕]** once and then using the Up **[▲]** or Down **[▼]** key select the Level **[LEu]** desired to trigger the Action, high **[h,9h]** or low **[Lobu]**.
10. Press the Infinity Key **[∞]** three times to return to the Home Page.

Using the RUI with ST Family Controllers









Note:

The steps shown below were created using PM firmware version 8.00. Slight differences may exist if your controller has a different version. The firmware version can be found by cycling power to the controller (first numerical value displayed in the upper display) or by navigating to the revision **[rEu]** prompt found in the Diagnostic Menu **[d,19]** in the Factory Page

1. Go to the Setup Page from the Home Page, press both the Up **[▲]** and Down **[▼]** keys for six seconds. **[R,]** will appear in the upper display and **[SEt]** will appear in the lower display.
2. Press the Up **[▲]** or Down **[▼]** key until **[FUN]** appears in the upper display and **[SEt]** will appear in the lower display.
3. Press the Advance Key **[⊕]** once. **[]** will appear in the upper display and **[FUN]** will appear in the lower display. At this time select instance 1.



Note:

As of this firmware revision (8.0), two instances appear to be available and selectable. However, instance 2 is provided for future firmware enhancements only.

4. Press the Advance Key  once and then using the Up  or Down  key to select Profile Start/Stop **PSES** as the Function .
5. Press the Advance Key  once and then using the Up  or Down  key select the Function Instance  (Function Instance equals Profile 1, 2, 3 or 4).
5. Press the Infinity Key  twice to return to the sub-menu, three times to return to the Home Page.

Default Home Pages

Watlow's patented user-defined menu system improves operational efficiency. The user-defined Home Page provides you with a shortcut to monitor or change the parameter values that you use most often. The default Home Pages for the EZ-ZONE PM Express, ST, Panel Mount (PM) and Rail Mount (RM) controllers are shown on the following pages. When a parameter normally located in the Setup Page or Operations Page is placed in the Home Page, it is accessible through both. If you change a parameter in the Home Page, it is automatically changed in its original page. If you change a parameter in its original page it is automatically changed in the Home Page.

Use the Advance Key  to step through the Home Page parameters. When not in pairs the parameter prompt will appear in the lower display, and the parameter value will appear in the upper display. You can use the Up  and Down  keys to change the value of writable parameters, just as you would in any other menu.

If Control Mode is set to Auto, the Process Value is in the upper display and the Closed Loop Set Point (read-write) is in the lower display.

If a profile is running, the process value is in the upper display and the Target Set Point (read only) is in the lower display. If Control Mode is set to Manual, the Process Value is in the upper display and the output power level (read-write) is in the lower display.

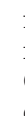









If Control Mode is set to Off, the Process Value is in the upper display and  (read only) is in the lower display.

If a sensor failure has occurred, the upper display will show four dashes  and the output power level (read-write) is in the lower display.



Changing the Set Point

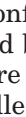





You can change the set point by using the Up  or Down  keys when a profile is not running.

Modifying the Home Page

To modify the Home Page proceed to the Factory Menu by pushing and holding the Advance  key and the Infinity  key for approximately six seconds. Upon entering the Factory Page the first menu will be the Custom Menu . Once there push the Advance  key where the lower display will show  and the upper display will show . Again, push the Advance  button where the prompt for the Process Value  will be displayed on the top and Parameter  on the bottom. Using the Up  or Down  arrow keys will allow for a customized selection of choice. There are twenty positions available that can be customized.

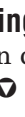
Modifying the Display Pairs

The Home Page, being a customized list of as many as 20 parameters can be configured in pairs of up to 10 via the Display Pairs  prompt found in the Global Menu  (Setup Page).

As stated above, the user can define pairs of prompts to appear on the display every time the Advance  key is pushed. For each controller the first pair will always be as defined in the Custom Menu and as stated will default (factory settings) to the Active Process Value loop 1 , and the Active Set Point loop 1 . For the Limit, it would be the Active Process Value , and Limit Status, either Safe  or Fail . When configuring the Custom Menu to your liking it should be noted that if 2 changeable (writable) prompts are displayed in a Pair, i.e., Control Mode on top and Idle Set Point on the bottom, only the lower display (Idle Set Point) can be changed.

On some controllers the display can also be configured to scroll automatically through multiple channels and then through all configured display pairs. Go to the Setup Page under the Global Menu and change the Display Time  prompt to something greater than 0. If set to 2, the display will scroll every 2 seconds from channel 1 to 2 (if present) and then through all of the custom pairs that are configured.

EZ-ZONE PM Express Home Page

Custom Menu Number	Home Page Display (defaults)	Parameter Name	Custom Menu Display (defaults)	Parameter Page and Menu
IF 4th digit of PN is equal to: PM _ [L] _ _ _ - _ _ _ _ B _ _ (Limit Controller)				
1 Upper or left display	(value only)	Active Process Value	ACP_v	Home Page
2 Lower or right display	SAFE or FAIL	Limit State	LSE	Home Page
----	(value only)	Limit Low Set Point	LLS	Operations Page
----	(value only)	Limit High Set Point	LhS	Operations Page
----	(value only)	Alarm Low Set Point	ALo	Operations Page
----	(value only)	Alarm high Set Point	Ah_i	Operations Page
----	(value only)	Calibration Offset	.CA	Operations Page
IF 4th digit of PN is equal to: PM _ [C] _ _ _ - _ _ _ _ B _ _ (PID Controller)				
1 Upper or left display	(value only)	Active Process Value	ACP_v	Home Page
2 Lower or right display	(value only)	Active Set Point	ACSP	Home Page
----	AUT_i	Autotune	----	Operations Menu
----	CM_i	User Control Mode	----	Operations Menu
----	hPb_i	Heat Proportional Band	----	Operations Menu
----	CPb_i	Cool Proportional Band	----	Operations Menu
----	t_i	Time Integral	----	Operations Menu
----	td_i	Time Derivative	----	Operations Menu
----	otb₁	Time Base Output 1	----	Operations Menu
----	otb₂	Time Base Output 2	----	Operations Menu
----	ALo_i	Alarm Low Set Point	----	Operations Menu
----	Ah_i	Alarm High Set Point	----	Operations Menu
----	.CA_i	Calibration Offset	----	Operations Menu

EZ-ZONE ST Home Page

Custom Menu Number	Home Page Display (defaults)	Parameter Name	Custom Menu Display (defaults)	Parameter Page and Menu
1 Upper Display	(value only)	Active Process Value	ACPV	Operations Page, Analog Input Menu
2 Lower Display	(value only)	*Active Set Point	ACSP	Operations Page, Monitor Menu
IF 4th digit of PN is equal to: ST _ [L] - _ _ _ _ - _ _ _ _ (Integrated Limit included)				
3	(value only)	Process Value Analog Input 2	Pra	Operations Page, Analog Input Menu
4	LSt	Limit State	LSt	Operations Page, Limit Menu
IF 4th digit of PN is equal to: ST _ [A] - _ _ _ _ - _ _ _ _				
3	None	----	----	----
4	None	----	----	----
5	CPM	User Control Mode	CPM	Operations Page, Monitor Menu
6	hPrI	Heat Power	hPr	Operations Page, Monitor Menu
7	CPrI	Cool Power	CPr	Operations Page, Monitor Menu
8	AUTI	Autotune	AUT	Operations Page, Loop Menu
9	IdSI	Idle Set Point	IdLE	Operations Page, Loop Menu
IF 12th digit of PN is equal to: ST _ _ - _ _ _ _ - [P] _ _ (Profile Ramp and Soak included)				
10	PStI	Profile Start	PStE	Home Page only (See ST User Manual, Profile Page Chapter.)
11	PACI	Profile Action Request	PACr	Home Page only (See ST User Manual, Profile Page Chapter.)
IF 12th digit of PN is equal to: ST _ _ - _ _ _ _ - [A, S] _ _				
10 to 20	(skipped)	None	nonE	(Add parameters to the Home Page in the Custom Menu, Factory Page.)

- * If Control Mode is set to Auto, the process value is in the upper display and the Closed Loop Set Point (read-write) is in the lower display.
- If a profile is running, the process value is in the upper display and the Target Set Point (read only) is in the lower display.
- If Control Mode is set to Manual, the process value is in the upper display and the output power level (read-write) is in the lower display.
- If Control Mode is set to Off, the process value is in the upper display and **oFF** (read only) is in the lower display.
- If a sensor failure has occurred, **----** is in the upper display and the output power level (read-write) is in the lower display.

EZ-ZONE PM Home Page

Custom Menu Number	Home Page Display	Home Page Defaults	Custom Menu Display (defaults)	Parameter Page and Menu
All Models				
1	Numerical value	Active Process Value (1)	ACP₁	Operations Page, Monitor Menu
2	Numerical value	Active Set Point (1)*	ACSP	Operations Page, Monitor Menu
IF 10th digit of PN is equal to: PM _ _ _ _ - _ [L, M] _ _ _ _				
3	Numerical value	Process Value (2)	ACP₂	Operations Page, Monitor Menu
4	SAFE or FAIL	Limit Status	ACSP	Home Page
IF 10th digit of PN is equal to: PM _ _ _ _ - _ [A, C, J, R, P, T] _ _ _ _				
3	P₁AR₂	Active Process Value (2)	ACP₂	Operations Page, Monitor Menu
4	CLSP₂	Closed Loop Set Point (2)	ACSP	Operations Page, Monitor Menu
5	CP₁	User Control Mode (1)	CP₁	Operations Page, Monitor Menu
6	HP₁	Heat Power (1)	HP₁	Operations Page, Monitor Menu
7	CP₁	Cool Power (1)	CP₁	Operations Page, Monitor Menu
8	AUT₁	Autotune (1)	AUT	Operations Page, Loop Menu
9	ID₁	Idle (1)	IDLE	Operations Page, Loop Menu
10	CP₂	User Control Mode (2)	CP₂	Operations Page, Monitor Menu
11	HP₂	Heat Power (2)	HP₂	Operations Page, Monitor Menu
12	CP₂	Cool Power (2)	CP₂	Operations Page, Monitor Menu
13	AUT₂	Autotune (2)	AUT	Operations Page, Loop Menu
14	ID₂	Idle (2)	IDLE	Operations Page, Loop Menu
IF 10th digit of PN is equal to: PM _ _ _ _ - _ [L, M] _ _ _ _				
15	LLS₁	Limit Set Point Low	LLS	Operations Page, Limit Menu
16	LHS₁	Limit Set Point High	LHS	Operations Page, Limit Menu
IF 10th digit of PN is equal to: PM _ _ _ _ - _ [R, B, N, E] _ _ _ _				
17	PSE₁	Start Profile	PSE₁	Home Page only (See Profile Page Chapter.)
18	PAC₁	Action Request	PAC₁	Home Page only (See Profile Page Chapter.)
19		None		
20		None		

- * If Control Mode is set to Auto, the process value is in the upper display and the Closed Loop Set Point (read-write) is in the lower display.
 If a profile is running, the process value is in the upper display and the Target Set Point (read only) is in the lower display.
 If Control Mode is set to Manual, the process value is in the upper display and the output power level (read-write) is in the lower display.
 If Control Mode is set to Off, the process value is in the upper display and **OFF** (read only) is in the lower display.
 If a sensor failure has occurred, **---** is in the upper display and the output power level (read-write) is in the lower display.

Note:

Numbers within parenthesis indicates the instance.

EZ-ZONE RMC (Controller) Home Page

Custom Menu Number	Home Page Display	Parameter Name	Custom Menu Display	Parameter Page and Menu
1 Upper Display	Numerical value	Active Process Value	Ac.Pv	Operations Page, Analog Input Menu
2 Lower Display	Numerical value	Active Set Point	Ac.SP	Operations Page, Monitor Menu
3	C.P.M	Control Mode	C.P.M	Operations Page, Loop Menu
4	h.P.r	Heat Power	h.P.r	Operations Page, Monitor Menu
5	C.P.r	Cool Power*	C.P.r	Operations Page, Monitor Menu
6	A.U.t	Autotune	A.U.t	Operations Page, Loop Menu
7	i.d.S	Idle Set Point	i.d.L	Operations Page, Loop Menu
IF 4th digit of PN is equal to: RM _ [3, 4] _ _ _ _ _ (Profile Ramp and Soak included)				
8	P.S.t	Profile Start	P.S.t	Home Page only (See Profile Page Chapter.)
9	P.A.C	Profile Action Request	P.A.C	Home Page only (See Profile Page Chapter.)
10 to 20	(skipped)	None	nonE	(Add parameters to the Home Page in the Custom Menu, Factory Page.)

EZ-ZONE RME (Expansion) Home Page

Custom Menu Number	Home Page Display	Parameter Name	Custom Menu Display	Parameter Page and Menu
1 Upper Display	(skipped)	None	nonE	(Add parameters to the Home Page in the Custom Menu, Factory Page.)
2 Lower Display	_ F	Display Units	C.F	Setup Page, Global Menu
3	A.L.o	Alarm Set Point Low	A.L.o	Operations Page, Alarm Menu
4	A.h.i	Alarm Set Point High	A.h.i	Operations Page, Alarm Menu
5 to 20	(skipped)	None	nonE	(Add parameters to the Home Page in the Custom Menu, Factory Page.)

EZ-ZONE RMS (Scanner) Home Page

Custom Menu Number	Home Page Display	Parameter Name	Custom Menu Display	Parameter Page and Menu
1 Upper Display	Numerical value	Active Process Value 1	Ac.Pv	Operations Page, Analog Input Menu
2 Lower Display	Numerical value	Active Process Value 2	Ac.Pv	Operations Page, Analog Input Menu
3 - 16	Same as above instance 3 - 16			
17 - 30	(skipped)	None	nonE	(Add parameters to the Home Page in the Custom Menu, Factory Page.)

EZ-ZONE RMH (High Density) Home Page

Custom Menu Number	Home Page Display	Parameter Name	Custom Menu Display	Parameter Page and Menu
1 Upper Display	Numerical value	Active Process Value 1	Rc.Pv	Operations Page, Analog Input Menu
2 Lower Display	Numerical value	Active Set Point 1	Rc.SP	Operations Page, Monitor Menu
3	C.P.M	Control Mode	C.P.M	Operations Page, Loop Menu
4 to 48	Same as above instance 4 - 16			
49 to 50	(skipped)	None	none	(Add parameters to the Home Page in the Custom Menu, Factory Page.)

EZ-ZONE RML (Limit) Home Page

Custom Menu Number	Home Page Display	Parameter Name	Custom Menu Display	Parameter Page and Menu
1 Upper Display	Numerical value	Active Process Value 1	Rc.Pv	Operations Page, Analog Input Menu
2 Lower Display	Safe or Fail	Limit Status	L.St	Setup Page, Global Menu
3 to 24	Same as above instance 4 - 16			
25 to 30	(skipped)	None	none	(Add parameters to the Home Page in the Custom Menu, Factory Page.)





EZ-ZONE RMA (Access) Home Page

Custom Menu Number	Home Page Display	Parameter Name	Custom Menu Display	Parameter Page and Menu
1 Upper Display	EZ-ZONE RMA	None	----	Cannot be modified
2 Lower Display	RMA Part Number	Part Number	----	Cannot be modified

4

Chapter 4: RUI Page

The RUI Page

To go to the RUI Page from the Home Page, press both the Down  and Advance  keys for three seconds.  (local) will appear in the Zone Display,  will appear in the upper display and  will appear in the lower display.

- Press the Up  or Down  key to move through the menus.
- Press the Advance Key  to select a menu.



 Communications Menu (1 to 2)

 Communications

Comm Instance 1

 Standard Bus Address

 Start Zone Address

 Number of Zones

Comm Instance 2

 Address Modbus

 Baud Rate Modbus

 Parity Modbus

 Modbus Word Order

 IP Address Mode

 IP Fixed Address (Part 1)

 IP Fixed Address (Part 2)

 IP Fixed Address (Part 3)

 IP Fixed Address (Part 4)

 IP Fixed Address (Part 5)

 IP Fixed Address (Part 6)

 IP Fixed Subnet (Part 1)

 IP Fixed Subnet (Part 2)

 IP Fixed Subnet (Part 3)

 IP Fixed Subnet (Part 4)

 IP Fixed Subnet (Part 5)

 IP Fixed Subnet (Part 6)

 IP Fixed Gateway (Part 1)

 IP Fixed Gateway (Part 2)

 IP Fixed Gateway (Part 3)

 IP Fixed Gateway (Part 4)

 IP Fixed Gateway (Part 5)

 IP Fixed Gateway (Part 6)

 Modbus TCP Enable

 EtherNet/IP Enable

 DeviceNet Address

 Baud Rate

 DeviceNet Quick Connect Enable

 Profibus DP Address

 Profibus DP Address Lock

 Display Units







 Global Menu

 Communications LED Action

 Menu Display Timer

 User Save

 User Restore

- Press the Advance Key  to move through the parameters of the menu.
- Press the Up  or Down  key to move through the parameter values.
- Press the Infinity Key  to move backwards through the levels: parameter to menu; menu to Home Page.
- Press and hold the Infinity Key  for two seconds to return to the Home Page.



 Gateway Menu

 Gateway (1 to 16)

 Device Enabled

 Device Status

 Modbus Address Offset

 CIP Instance Offset

 CIP Implicit Output Assembly Member Quantity

 CIP Implicit Input Assembly Member Quantity

 Profibus DP Slot Offset



 Security Setting Menu

 Password Enabled

 Read Lock

 Write Security

 Locked Access Level

 Rolling Password

 User Password

 Administrator Password



 Security Setting Menu

 Public Key

 Password



 Diagnostics Menu

 Part Number

 Firmware Revision

 Software Build Number

 Serial Number

 Date of Manufacture

 IP Actual Address Mode

 IP Actual Address Part 1

 IP Actual Address Part 2

 IP Actual Address Part 3

 IP Actual Address Part 4

 IP Actual Address Part 5

 IP Actual Address Part 6

Display	Parameter name Description	Range	Default	Modbus Relative Ad- dress	CIP Class Instance Attribute hex (dec)	Profibus Index	Param- eter ID	Data Type & Read/ Write
[COP] (instance 2 appears if PN is equal to: EZK _- [2, 3, 5 or 6] _-A _AA) [RU] Communications Menu								
[AdS] [Ad.S]	Communications 1 RUI Address Set the Standard Bus address of this RUI. Each RUI on the network must have a unique address.	1 to 8	1	410	0x96 (150) 1 1	----	17001	uint RWE
[St.Zn] [St.Zn]	Communications 1 Start Zone Set the lowest Standard Bus address that this RUI will communicate with. Narrowing the range of addresses will speed up some operations.	1 to 24	1	----	----	----	17004	
[nU.Zn] [nU.Zn]	Communications 1 Number of Zones Set the number of contiguous Standard Bus addresses that this RUI will communicate with. Narrowing the range of addresses will speed up some operations.	1 to 24	8	----	----	----	17005	
[Ad.M] [Ad.M]	Communications 2 Address Modbus Set the network address of this gateway. Each device on the network must have a unique address.	1 to 247	1	432	0x96 (150) 2 2	----	17007	uint RWE
[bAUd] [bAUd]	Communications 2 Baud Rate Modbus Set the speed of this controller's gateway to match the speed of the serial network.	9,600 19,200 38,400	9,600	434	0x96 (150) 2 3	----	17002	uint RWE
[PAr] [PAr]	Communications 2 Parity Modbus Set the parity of this gateway to match the parity of the serial network.	[nonE] None [EVEN] Even [odd] Odd	None	436	0x96 (150) 2 4	----	17003	uint RWE
[M.hL] [M.hL]	Communications 2 Modbus Word Order Select the word order of the two 16-bit words in the floating-point values.	[LoHi] Low-High [HiLo] High-Low	Low-High	438	0x96 (150) 2 5	----	17043	uint RWE
[iP.M] [iP.M]	Communications 2 IP Address Mode Select DHCP to let a DHCP server assign an address to this gateway.	[dHCP] DHCP [FAdd] Fixed Address	DHCP	----	----	----	17012	
[ip.F1] [ip.F1]	Communications 2 IP Fixed Address Part 1 Set the IP address of this gateway. Each device on the network must have a unique address. Note: Power must be cycled for a modified IP address to take affect.	0 to 255	169	----	----	----	17044	uint RW

Display	Parameter name Description	Range	Default	Modbus Relative Ad- dress	CIP Class Instance Attribute hex (dec)	Profibus Index	Param- eter ID	Data Type & Read/ Write
[.PF2] [ip.F2]	<i>Communications 2</i> IP Fixed Address Part 2 Set the IP address of this gateway. Each device on the network must have a unique address.	0 to 255	254	----	----	----	17045	uint RW
[.PF3] [ip.F3]	<i>Communications 2</i> IP Fixed Address Part 3 Set the IP address of this gateway. Each device on the network must have a unique address.	0 to 255	1	----	----	----	17046	uint RW
[.PF4] [ip.F4]	<i>Communications 2</i> IP Fixed Address Part 4 Set the IP address of this gateway. Each device on the network must have a unique address.	0 to 255	1	----	----	----	17047	uint RW
[.PF5] [ip.F4]	<i>Communications 2</i> IP Fixed Address Part 5 Set the IP address of this gateway. Each device on the network must have a unique address.	0 to 255	1	----	----	----	17048	uint RW
[.PF6] [ip.F6]	<i>Communications 2</i> IP Fixed Address Part 6 Set the IP address of this gateway. Each device on the network must have a unique address.	0 to 255	1	----	----	----	17049	uint RW
[.PS1] [ip.S1]	<i>Communications 2</i> IP Fixed Subnet Part 1 Set the IP subnet mask for this gateway.	0 to 255	255	----	----	----	17020	uint RW
[.PS2] [ip.S2]	<i>Communications 2</i> IP Fixed Subnet Part 2 Set the IP subnet mask for this gateway.	0 to 255	255	----	----	----	17021	uint RW
[.PS3] [ip.S1]	<i>Communications 2</i> IP Fixed Subnet Part 3 Set the IP subnet mask for this gateway.	0 to 255	0	----	----	----	17022	uint RW
[.PS4] [ip.S4]	<i>Communications 2</i> IP Fixed Subnet Part 4 Set the IP subnet mask for this gateway.	0 to 255	0	----	----	----	17023	uint RW
[.PS5] [ip.S4]	<i>Communications 2</i> IP Fixed Subnet Part 5 Set the IP subnet mask for this gateway.	0 to 255	0	----	----	----	17024	uint RW
[.PS6] [ip.S4]	<i>Communications 2</i> IP Fixed Subnet Part 6 Set the IP subnet mask for this gateway.	0 to 255	0	----	----	----	17025	uint RW
[.PG1] [ip.g1]	<i>Communications 2</i> IP Fixed Gateway Part 1 Set the router IP address for the remote network.	0 to 255	0	----	----	----	17026	uint RW

Display	Parameter name Description	Range	Default	Modbus Relative Ad- dress	CIP Class Instance Attribute hex (dec)	Profibus Index	Param- eter ID	Data Type & Read/ Write
<input type="checkbox"/> P92 [ip.g2]	<i>Communications 2</i> IP Fixed Gateway Part 2 Set the router IP address for the remote network.	0 to 255	0	----	----	----	17027	uint RW
<input type="checkbox"/> P93 [ip.g3]	<i>Communications 2</i> IP Fixed Gateway Part 3 Set the router IP address for the remote network.	0 to 255	0	----	----	----	17028	uint RW
<input type="checkbox"/> P94 [ip.g4]	<i>Communications 2</i> IP Fixed Gateway Part 4 Set the router IP address for the remote network.	0 to 255	0	----	----	----	17029	uint RW
<input type="checkbox"/> P95 [ip.g4]	<i>Communications 2</i> IP Fixed Gateway Part 5 Set the router IP address for the remote network.	0 to 255	0	----	----	----	17030	uint RW
<input type="checkbox"/> P96 [ip.g4]	<i>Communications 2</i> IP Fixed Gateway Part 6 Set the router IP address for the remote network.	0 to 255	0	----	----	----	17031	uint RW
<input type="checkbox"/> P9bE [Mb.E]	<i>Communications 2</i> Modbus TCP Enable Activate Modbus TCP.	<input type="checkbox"/> no No <input checked="" type="checkbox"/> YES Yes	Yes	----	----	----	17041	uint RWE
<input type="checkbox"/> EiPE [EiP.E]	<i>Communications 2</i> EtherNet/IP™ Enable Activate Ethernet/IP™.	<input type="checkbox"/> no No <input checked="" type="checkbox"/> YES Yes	Yes	----	----	----	17042	uint RWE
<input type="checkbox"/> Ad.d [Ad.d]	<i>Communications 2</i> DeviceNet™ Node Address Set the DeviceNet™ address for this gateway.	0 to 63	63	----	----	----	17052	uint RWE
<input type="checkbox"/> BAud [bAUd]	<i>Communications 2</i> Baud Rate DeviceNet™ Set the speed of this gateway's communications to match the speed of the serial network.	<input checked="" type="checkbox"/> 125 125 kb <input type="checkbox"/> 250 250 kb <input type="checkbox"/> 500 500 kb	125	----	----	----	17053	uint RWE
<input type="checkbox"/> FC.E [FC.E]	<i>Communications 2</i> DeviceNet™ Quick Connect Enable Allows for immediate communication with the scanner upon power up.	<input type="checkbox"/> no No <input checked="" type="checkbox"/> YES Yes	No	----	----	----	17054	uint RWE
<input type="checkbox"/> PAAdd [P.Add]	<i>Communications 2</i> Profibus Address Set the Profibus DP address for this gateway.	<input type="checkbox"/> no No <input checked="" type="checkbox"/> YES Yes	No	----	----	----	17060	uint RWE
<input type="checkbox"/> ALoc [A.Loc]	<i>Communications 2</i> Profibus DP address lock When set to yes will not allow address to be changed using software. Can be changed from front panel.	<input type="checkbox"/> no No <input checked="" type="checkbox"/> YES Yes	No	----	----	----	17061	uint RWE
<input type="checkbox"/> C_F [C_F]	<i>Communications 2</i> Display Units Select which scale to use for temperature passed over communications port 2.	<input type="checkbox"/> F F <input checked="" type="checkbox"/> C C	F	440	0x96 (150) 2 6	25	17050	uint RWE

Display	Parameter name Description	Range	Default	Modbus Relative Ad- dress	CIP Class Instance Attribute hex (dec)	Profibus Index	Param- eter ID	Data Type & Read/ Write
Global Menu [G.LbL] [R.U.]								
[C.LEd] [C.LEd]	<i>Global Menu</i> Communications LED Action Turns comms LED on or off for selected comms ports.	[Con1] Comm port 1 [Con2] Comm port 2 [both] Comm port 1 and 2 [OFF] Off	Both	386	0x67 (103) 1 0x0E (14)	----	3014	uint RWES
[d.ti] [d.ti]	<i>Global Menu</i> Display Time Time delay in toggling between channel 1 and channel 2.	0 to 60	0	----	0x67 (103) 1 0x1D (29)	----	3029	uint RWES
[USr.S] [USr.S]	<i>Global Menu</i> User Settings Save Save all of this controller's settings to the selected set.	[SEt1] User Set 1 [SEt2] User Set 2 [none] None	None	26	0x65 (101) 1 0x0E (14)	8	1014	uint RWE
[USr.r] [USr.r]	<i>Global Menu</i> User Restore Settings Replace all of this controller's settings with another set.	[FctY] Factory (31) [none] None (61) [SEt1] User Set 1 (101) [SEt2] User Set 2 (102)	None	24	0x65 (101) 1 0x0D (13)	7	1013	uint RWE
Gateway Menu [G.LwL] (menu appears if PN is equal to: EZK _- [2, 3, 5 or 6] _-A _AA) [R.U.]								
[du.En] [du.En]	<i>Gateway (1 to 16)</i> Gateway Enabled Turn the gateway for this Standard Bus controller address on or off.	[no] No [yEs] Yes	Yes	452 [offset 20]	0x7C (124) 1 to 0x18 (24) 2	18	24002	uint RWE
[du.St] [du.St]	<i>Gateway (1 to 16)</i> Device Status Indicates whether the RUI and gateway are communicating.	[OFF] Off [on] On	Off	460 [offset 20]	0x7C (124) 1 to 0x18 (24) 6	----	24006	uint R
[M.oF] [M.oF]	<i>Gateway (1 to 16)</i> Modbus Address Offset Set the Modbus offset for this Standard Bus controller address.	0 to 9,999	0	454 [offset 20]	0x7C (124) 1 to 0x18 (24) 3	----	24003	uint RWE
[oSt] [oSt]	<i>Gateway (1 to 16)</i> CIP Instance Offset Set CIP instance member offset for this Standard Bus controller address.	0 to 255	0	456 [offset 20]	0x7C (124) 1 to 0x18 (24) 4	----	24004	uint RWE
[Ao.nb] [Ao.nb]	<i>Gateway (1 to 16)</i> CIP Implicit Output Assembly Member Quantity Set the CIP assembly size for this Standard Bus controller address.	0 to 20	0	466 [offset 20]	0x7C (124) 1 to 0x18 (24) 9	----	24009	uint RWE
[Ai.nb] [Ai.nb]	<i>Gateway (1 to 16)</i> CIP Implicit Input Assembly Member Quantity Set the CIP assembly size for this Standard Bus controller address.	0 to 20	0	46/8 [offset 20]	0x7C (124) 1 to 0x18 (24) 0x0A (10)	----	24010	uint RWE

Display	Parameter name Description	Range	Default	Modbus Relative Ad- dress	CIP Class Instance Attribute hex (dec)	Profibus Index	Param- eter ID	Data Type & Read/ Write
<input type="checkbox"/> SoF [So.F]	<i>Gateway (1 to 16)</i> Profibus DP Slot Offset Set Profibus instance mem- ber offset for this Standard Bus controller address.	0 to 254	Gateway instance 1 (0), 2 (20), 3 (40), all other instances (up to 16) multiple of 20	----	0x7C (124) 1 to 0x18 (24) 0x0B (11)	19	24011	uint RWE
<input type="checkbox"/> LoC <input type="checkbox"/> ru Security Setting Menu								
<input type="checkbox"/> PRSE [LoC.P]	<i>Security Setting</i> Password Enable Turn security features on or off.	<input type="checkbox"/> OFF Off <input type="checkbox"/> on On	Off	----	----	----	3009	uint RWE
<input type="checkbox"/> rLoC [rLoC]	<i>Security Setting</i> Read Lock Set the read security clear- ance level. The user can ac- cess the selected level and all lower levels. If the Set Lockout Security level is higher than the Read Lockout Security, the Read Lockout Security level takes priority.	1 to 5	5	378	0x67 (103) 1 0x0A (10)	----	3010	uint RWE
<input type="checkbox"/> SLoC [SLoC]	<i>Security Setting</i> Write Security Set the write security clear- ance level. The user can ac- cess the selected level and all lower levels. If the Set Lockout Security level is higher than the Read Lockout Security, the Read Lockout Security level takes priority.	0 to 5	5	380	0x67 (103) 1 0x0B (11)	----	3011	uint RWE
<input type="checkbox"/> LoCL [LoC.L]	<i>Security Setting</i> Locked Access Level Determines user level menu visibility when security is enabled. See Features section under Password Security.	1 to 5	5	----	----	----	3016	uint RWE
<input type="checkbox"/> roLL [roLL]	<i>Security Setting</i> Rolling Password When power is cycled a new Public Key will be displayed.	<input type="checkbox"/> OFF Off <input type="checkbox"/> on On	Off	----	----	----	3019	uint RWE
<input type="checkbox"/> PAS.u [PAS.u]	<i>Security Setting</i> User Password Used to acquire access to menus made available through the Locked Access Level setting.	10 to 999	63	----	----	----	3017	uint RWE
<input type="checkbox"/> PAS.A [PAS.A]	<i>Security Setting</i> Administrator Password Used to acquire full access to all menus.	10 to 999	156	----	----	----	3018	uint RWE

Display	Parameter name Description	Range	Default	Modbus Relative Ad- dress	CIP Class Instance Attribute hex (dec)	Profibus Index	Param- eter ID	Data Type & Read/ Write
U L o C r u i Unlock Security Setting Menu								
[CodE] [CodE]	<i>Security Setting</i> Public Key If Rolling Password turned on, generates a random number when power is cycled. If Rolling Password is off fixed number will be displayed.	Customer Specific	0	----	----	----	3020	uint R
[PASS] [PASS]	<i>Security Setting</i> Password Number returned from calculation found in Features section under Password Security.	-1999 to 9999	0	----	----	----	3022	int RW
d . A 9 r u i Diagnostics Menu								
[Pn] [Pn]	<i>Diagnostics Menu</i> Part Number Display the RUI/GTW part number.	15 characters	None	----	0x65 (101) 1 9	5	1009	string R
[rEu] [rEu]	<i>Diagnostics Menu</i> Software Revision Display the RUI/GTW firm-ware revision number.	1 to 10	----	4	0x65 (101) 1 3	6	1003	dint R
[S.bLd] [S.bLd]	Software Build View the software build number.	0 to 2, 147,483,647	----	8	0x65 (101) 1 5	----	1005	dint R
[Sn] [Sn]	Serial Number View the controller serial number.	0 to 2, 147,483,647	----	12	0x65 (101) 1 7	----	1032	dint R
[dAtE] [dAtE]	Date of Manufacture View the controller manu-facture date.	0 to 2, 147,483,647	----	14	0x65 (101) 1 8	----	1008	dint R
[iP.AC] [iP.AC]	<i>Diagnostics Menu</i> IP Actual Address Mode View the addressing mode of the gateway in slot B of this RUI.	[dhCP] DHCP [FRdd] Fixed Ad-dress	DHCP	----	----	----	17013	uint R
[iP.A1] [iP.A1]	<i>Diagnostics Menu</i> IP Actual Address Part 1 View or change the first part of the IP address of the gateway in slot B of this RUI..	0 to 255	None	----	----	----	17014	uint R
[iP.A2] [iP.A2]	<i>Diagnostics Menu</i> IP Actual Address Part 2 View or change the second part of the IP address of the gateway in slot B of this RUI..	0 to 255	None	----	----	----	17015	uint R
[iP.A3] [iP.A3]	<i>Diagnostics Menu</i> IP Actual Address Part 3 View or change the third part of this controller's IP address.	0 to 255	None	----	----	----	17016	uint R

Display	Parameter name Description	Range	Default	Modbus Relative Ad- dress	CIP Class Instance Attribute hex (dec)	Profibus Index	Param- eter ID	Data Type & Read/ Write
<input type="checkbox"/> PR4 [iP.A4]	<i>Diagnostics Menu</i> IP Actual Address Part 4 View or change the fourth part of this controller's IP address.	0 to 255	None	----	----	----	17017	uint R
<input type="checkbox"/> PR5 [iP.A5]	<i>Diagnostics Menu</i> IP Actual Address Part 5 View or change the fourth part of this controller's IP address.	0 to 255	None	----	----	----	17018	uint R
<input type="checkbox"/> PR6 [iP.A6]	<i>Diagnostics Menu</i> IP Actual Address Part 6 View or change the fourth part of this controller's IP address.	0 to 255	None	----	----	----	17019	uint R
<input type="checkbox"/> SEAE [StAt]	Profibus DP Status Indicates if the Profibus card is ready or currently running.	<input checked="" type="checkbox"/> Edy Ready <input type="checkbox"/> rn9 Running	None	----	----	----	17063	uint R

5

Chapter 5: Using an RUI/Gateway

Conceptual View of the RUI/GTW

As shown in the following network screen shots the gateway allows for connectivity between dissimilar networks. Within the Watlow controllers there are many parameters (members), of which, some can be read and some read and or written to. As an example, the Process Value can be read only, where the Closed Loop Set Point can be read and or written to. In order for these parameters to be available on the field bus side of the gateway some basic setup is required in the RUI/GTW. Communications instance 1 will always represent the Standard Bus side of the network where communications instance 2 represents the field bus side. On each side of the RUI/GTW there are addresses (unique to each network) that need to be set up; there are also some network specific settings as well. As an example, when using DeviceNet™ as the field bus of choice, the network baud rate and node address must be specified. When using Ethernet the user can enable EtherNet/IP™ and or Modbus TCP. On the Standard Bus side, the user will determine the total number of EZ-ZONE® controllers (slaves) to scan (starting and end zones). Once the RUI/GTW is configured, all accessible parameters for each of the EZ-ZONE controllers on the Standard Bus network will be available on the field bus side of the Gateway.

Note:

Excessive writes through the gateway to other EZ-ZONE family controllers may cause premature EEPROM failure. For more detail, open the associated controller User Guide to find the Non-Volatile Save prompt **[nVS]**. Turn to the Setup Page and then under the Com Menu and set this prompt to Yes (enable writes) or No (disable writes). To learn more turn to the section entitled "Saving Settings to Non-volatile Memory".

Using RUI Lockout and Password Security

If unintentional changes to parameter settings might raise safety concerns or lead to downtime, you can use the lockout feature to make them more secure. There are two methods of lockout that can be deployed through the RUI, both of which are accessible from the RUI Page. Method 1 is discussed below.

Method 1- Change the value of the Read Lock **[rLoc]** (1 to 5) and Set Lock **[SLoc]** (0 to 5) prompts where the higher the value or setting for each translates to a higher security clearance (greater access).

Note:

When using Method 1 Lockout all settings can be

modified by anyone who knows how to find their way to the **[SLoc]** and **[rLoc]** parameters.

Note:

These lockout settings apply to the RUI only. When utilizing Method 1 described above, the RUI settings may serve as an override to the local PM settings when it too is using Method 1. As an example, if a PM control has Read Lock set to 1 and the RUI has the same prompt set to 5, the RUI will have full visibility to all PM menus when connected to it.

An example of Method 1 lockout usage could be that it is determined that an operator should have read access to all menus while allowing write access to the Home Page only.

1. Press and hold the Advance and Infinity keys for approximately 6 seconds to enter the RUI Page
2. Navigate to the **[Loc]** Menu using the Up or Down arrow keys
3. Using the green Advance key navigate to the Read Lockout Security **[rLoc]** and change it to 5
4. Push the green Advance key and navigate to the and Set Lockout Security **[SLoc]** changing it to 1

Using Lockout Method 1 (Read and Set Lock)

There are two Pages within an RUI (Home and RUI Page) that are always visible regardless of Read and Set Lock settings. However, the menus that are visible and which ones can be written to are dependent on these settings. Looking at the table below, "Y" equates to yes (can write/read) where "N" equates to no (cannot write/read). The colored cells simply differentiate one level from the next. As stated previously, the Set Lockout has 6 levels (0 to 5) of security where the Read Lockout has 5 (1 to 5). Therefore, level "0" applies to Set Lockout only.

RUI Page Menus [rLoc] and [SLoc]						
Menus	Security Level					
	0	1	2	3	4	5
Communications Menu	N	N	N	N	N	Y
Global Menu	N	N	N	N	N	Y
Gateway Menu	N	N	N	N	N	Y
Lock Menu	N*	Y*	Y*	Y*	Y*	Y
Diagnostic Menu**	N	Y	Y	Y	Y	Y

* Visible, with limited write capabilities. Read and Set Lock can always be written to.

** Always visible and never writable

Note:

Using Method 1 Lockout all settings can be modified by anyone who knows how to find their way to the **[SLoC]** and **[rLoC]** parameters

Method 2- Enable Password Security **[PASE]** and then modify the Lock Level **[LoCL]** value which ranges from 1 to 5. See the section entitled Using Lockout Method 2 for more detail.

Using Lockout Method 2 (Password Enable)

It is sometimes desirable to apply a higher level of security to the RUI where a password would be required to access the menus. If Password Enabled **[PASE]** in the RUI Page under the **[LoC]** Menu is set to on, an overriding Password Security will be in effect for the RUI. Without the appropriate password (User or Administrator), specified menus within the RUI will remain inaccessible based on the Locked Access Level **[LoCL]** prompt. On the other hand, a User with a password would have visibility restricted by the Read Lockout **[rLoC]** and the Set Lockout **[SLoC]** settings. As an example, with the following settings:

- Password **[PASE]** Enabled
- Locked Access Level **[LoCL]** set to 1
- Read **[rLoC]** and Set **[SLoC]** Lock set to 5

a User (having entered a User password) would have access to all menus with the exception of the Lock menu. Therefore, Read and Set Lock cannot be changed. If an Administrator enters the appropriate password all menus would then become available again.

How to Enable Password Security

Follow the steps below:

1. Go to the RUI Page by holding down the Advance **[⊕]** key and the Down **[⬇]** key for approximately six seconds
2. Push the Down **[⬇]** or Up **[⬆]** key to get to the **[LoC]** menu. Again push the Advance **[⊕]** key until the Password Enabled **[PASE]** prompt is visible
3. Push either the Down **[⬇]** or Up **[⬆]** key to turn it on. Once on, 4 new prompts will appear:
 - a. **[LoCL]**, Locked Access Level (1 to 5) corresponding to the lockout table above.
 - b. **[roLL]**, Rolling Password will change the Customer Code every time power is cycled.
 - c. **[PASu]**, User Password which is needed for a User to acquire access to the control.
 - d. **[PASA]**, Administrator Password which is needed to acquire administrative access to the control.

The Administrator can either change the User and or the Administrator password or leave them in the default state. Once Password Security is enabled they will no longer be visible to anyone other than the Administrator. In other words the Lock Menu **[LoC]** is not available to a User. As can be seen in the formula that follows either the User or Administrator will

need to know what those passwords are to acquire a higher level of access to the control. Back out of this menu by pushing the Infinity **[∞]** key. Once out of the menu, the Password Security will be enabled.

How to Acquire Access to the Control

To acquire access to any inaccessible Menus, go to the RUI Page and enter the **[ULoC]** menu. Once there follow the steps below:

Note:

If Password Security (Password Enabled **[PASE]** is on) is enabled the two prompts mentioned below in the first step will not be visible. If the password is unknown, call the individual or company that originally setup the control.

1. Acquire either the User Password **[PASu]** or the Administrator Password **[PASA]**.
2. Push the Advance **[⊕]** key until the Code **[Code]** prompt appears.

Note:

- a. If the the Rolling Password is off push the Advance **[⊕]** key until the Password **[PASS]** prompt is displayed. Proceed to either step 7a or 8a. Pushing the Up **[⬆]** or Down **[⬇]** arrow keys enter either the User or Administrator Password. Once entered, push and hold the Infinity **[∞]** key for two seconds to return to the Home Page.
- b. If the Rolling Password **[roLL]** was turned on proceed on through steps 3 - 9.
3. Assuming the Code **[Code]** prompt (Public Key) is still visible on the face of the control simply push the Advance key **[⊕]** to proceed to the Password **[PASS]** prompt. If not find your way back to the RUI Page as described above.
4. Execute the calculation defined below (7b or 8b) for either the User or Administrator.
5. Enter the result of the calculation in the upper display by using the Up **[⬆]** and Down **[⬇]** arrow keys or use EZ-ZONE Configurator Software.
6. Exit the RUI Page by pushing and holding the Infinity **[∞]** key for two seconds.

Formulas used by the User and the Administrator to calculate the password follows:

Passwords equal:

7. User

- a. If Rolling Password **[roLL]** is Off, Password **[PASS]** equals User Password **[PASu]**.
- b. If Rolling Password **[roLL]** is On, Password **[PASS]** equals: $(\text{[PASu]} \times \text{code}) \text{ Mod } 929 + 70$

8. Administrator

- a. If Rolling Password **[roLL]** is Off, Password **[PASS]** equals User Password **[PASA]**.
- b. If Rolling Password **[roLL]** is On, Password **[PASS]** equals: $(\text{[PASA]} \times \text{code}) \text{ Mod } 997 + 1000$

Differences Between a User Without Password, User With Password and Administrator

- User **without** a password is restricted by the Locked Access Level [LoCL].
- A User **with** a password is restricted by the Read Lockout Security [rLoC] never having access to the Lock Menu [LoC].
- An Administrator is restricted according to the Read Lockout Security [rLoC] however, the Administrator has access to the Lock Menu where the Read Lockout can be changed.

An example using Method 2 lockout may be a case where once the RUI gateway is setup downtime due to inadvertent and unwanted changes to the RUI would be unacceptable. By enabling Password Security all menus (with the exception of Unlock [UloC]) would be inaccessible until a valid password is entered.

1. Press and hold the Advance and Down arrow keys for approximately 6 seconds to enter the RUI Page
2. Navigate to the [LoC] Menu using the Up or Down arrow keys.
3. Using the green Advance key navigate to the Password Enable [PASE] prompt and change it to on.
4. Push the green Advance key and navigate to the Lock Level [LoCL] prompt changing it to 1.
5. Push the green Advance key and select whether or not rolling password [roLL] should be on or off.
6. Push the green Advance key and select a User Password [PASu] by using the Up or Down arrow keys.
7. Push the green Advance key and select an Administrator Password [PASR] by using the Up or Down arrow keys.
8. Push and hold the Infinity key for 3 seconds to return to the Home Page.

Using Modbus RTU

Communications To/From a Master:

Once the gateway instance is enabled for Modbus RTU there is one other prompt [rLoF] (Modbus Offset) that will have an impact on which parameter is read or written to as well as which controller.

As an example, lets assume the offsets are as shown in the graphic on the following page and the Master wants to read instance one Closed Loop Set Point from both Standard Bus address 1 and 4. Open up the associated PM Users Guide and determine whether or not the controller is configured to use Map 1 or Map 2 Modbus addresses. This can be found in the Setup Page under the Com Menu. Once this is determined, turn to the Operations Page and look in the Loop Menu for Closed Loop Set Point. If using Map 1

you'll notice that the Modbus register that holds the Closed Loop Set Point value is 2160; if using Map2 then the address would be 2640. To read instance one Closed Loop Set Point from Standard Bus address 1 the appropriate absolute Modbus address would be:

$$2160 + 400001 + \text{Modbus offset (0)} = 402161.$$

To read the closed loop set point from Standard Bus address 4 the absolute address would be:

$$2160 + 400001 + \text{Modbus offset (15000)} = 417161.$$

When considering what the offsets will be for each control, first determine the highest Modbus address that you will need to access from any given control while keeping in mind that the last available Modbus address is 465535. Ensure the offsets for each control do not overlap one another. As a point of reference, the table below shows the maximum number of Modbus registers in each of the EZ-ZONE controls.

With Profiles

PM	ST	RMC
8,500	8,000	43,400

Without Profiles

PM Express	PM	ST	RMC	RMH	RMS	RML	RME	RMA
2,200	4,000	2,200	5,300	17,000	18,000	9,500	7,000	5,500

Note:

The Modbus Offset [rLoF] as modified through the RUI cannot exceed 9999. Therefore, if it is desired to utilize a Modbus offset as shown in the following graphic (above 9999) it must be entered using EZ-ZONE Configurator software. This software can be downloaded free of charge from the Watlow web site:

http://www.watlow.com/products/software/zone_config.cfm

Modbus - Using Programmable Memory Blocks

All EZ-ZONE controllers equipped with the Modbus protocol feature a block of addresses that can be configured by the user to provide direct access to a list of 40 user configured parameters. This allows the user easy access to this customized list by reading from or writing to a contiguous block of registers.

Note:

To use the User Programmable Memory Blocks feature, Map 2 must be selected in the controller and the RUI. The RUI and the control must be set the same. For the control change the mapping [rRRP] via the Setup Page under the [CoPP] Menu. For the RUI navigate to the RUI Page and then the [CoPP] Menu

To acquire a better understanding of the tables found in the back of this manual (See Appendix: [Modbus Programmable Memory Blocks](#)) please read through the text below which defines the column headers used.

Assembly Definition Addresses

- Fixed addresses used to define the parameter that will be stored in the "Working Addresses", which may also be referred to as a pointer. The value stored in these addresses will reflect (point to) the Modbus address of a parameter within the controller.

Memory Blocks" found in the appendix of this Users Guide reflects the assemblies and their associated addresses.

To learn more about the Modbus RTU protocol point your browser address below:

<http://www.modbus.org>

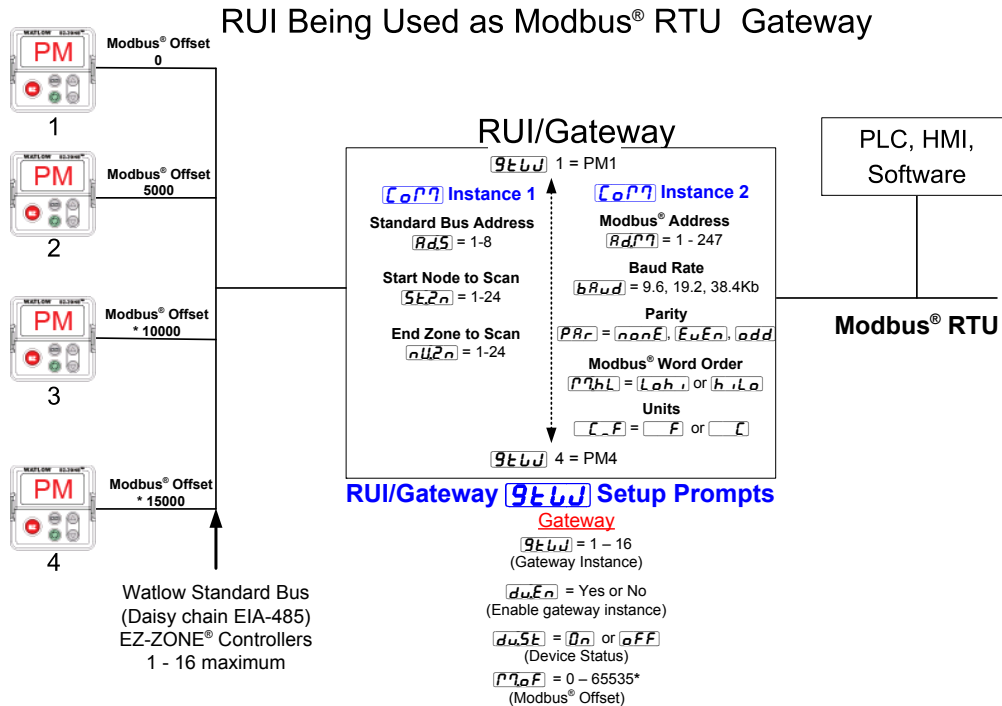

Assembly Working Addresses

- Fixed addresses directly related to their associated "Assembly Definition Addresses" (i.e., Assembly Working Addresses 200 & 201 will assume the parameter pointed to by Assembly Definition Addresses 40 & 41).

When the Modbus address of a target parameter is stored in an "Assembly Definition Address" its corresponding working address will return that parameter's actual value. If it's a writable parameter, writing to its working register will change the parameter's actual value.

As an example (using the EZ-ZONE ST Users Guide), Modbus register 360 and 361 (Map 2) contains the Analog Input 1 Process Value (See Operations Page, Analog Input Menu). If the value 360 and 361 is loaded into Assembly Definition Addresses 90 and 91, the Process Value sensed by Analog Input 1 will also be stored in Modbus registers 250 and 251. Note that by default this parameter is also stored in working registers 240 and 241 as well.

Note:

When changing the assembly as in the example above a multi-write function must be used, i.e., writing 360 to register 90 and 361 to register 91. All members in the assembly are 32 bits.

The table identified as "Modbus Programmable

Note:

To minimize traffic and enable better throughput on Standard Bus, set the Number of Zones prompt [nUZn] in the RUI to the maximum number of EZ-ZONE controllers on the network to be scanned.

Note:

The logic used when determining the Modbus offset is based on the number of Modbus addresses needed for any given controller. In the above example, each PM controller would have access to the first 5000 Modbus registers (40001 - 405001).

Note:

If using a legacy EZ-ZONE ST controller with a firmware version less than 3.0, consider using the Modbus addresses listed in the ST Users Guide in the column entitled "RUI/GTW Modbus". If the firmware in the ST is 3.0 or higher new features were added and made accessible through the Map 2 registers. If interested in using the new features today or perhaps in the future configure the ST for Map2 Modbus registers.

CIP - Communications Capabilities

Communications using CIP (EtherNet/IP and DeviceNet) can be accomplished with any EZ-ZONE controller using an RUI/GTW. Reading or writing when

using CIP can be accomplished via explicit and or implicit communications. Explicit communications usually requires the use of a message instruction within the Programmable Logic Controller (PLC) but there are other ways to do this as well. Implicit communications is also commonly referred to as polled communications. When using implicit communications there is an I/O assembly that would be read or written to; the default assemblies are embedded into the firmware of the controller and are different for each. Watlow refers to these assemblies as the T to O (Target to Originator) and the O to T (Originator to Target) assemblies where the Target is always the EZ-ZONE controller and the Originator is the PLC or Master on the network. The O to T assembly is made up of 20 (32 bit) members that are user configurable where the T to O assembly consists of 21 (32 bit) members. The first member of the T to O assembly is called the Device Status, it is unique to the RUI/GTW and cannot be changed. Bits 16 - 31 of this 32 bit word represents the communications status of the EZ-ZONE controllers on the Standard Bus side of the RUI/GTW when enabled. Once a Zone is enabled, valid communications will be represented with the bit set to a "1", if set to "0", the RUI/GTW is not communicating with the zone. Bit 16 represents Zone 1 where bit 31 represents Zone 16. The 20 members that follow Device

Limit Menu) write the value of 0x70, 0x01 and 0x01 (Class, Instance and Attribute respectively) to 0x77, 0x01 and 0x0E. Once executed, writing a value of zero to this member will reset a limit assuming the condition that caused it is no longer present.

Note:

When changing the implicit assembly of any given controller through the RUI/GTW ensure that the CIP Instance Offset is added to the documented instance for any given parameter as well as the assembly instance. As an example, if it were desired to do the above operation on PM3 the value to write would now be 0x70, 0x09 and 0x01 (Class, Instance and Attribute respectively) to 0x77, 0x09 and 0x0E. Notice that the CIP Offset was added to each.

Using DeviceNet™

Communications To/From Third Party Device:

When using the DeviceNet protocol, there are two methods used in communicating, implicitly and explicitly. Once the gateway instance is enabled there are two prompts that relate directly to these forms of communication.

Use the graphic below in reference to the descriptions that follow.

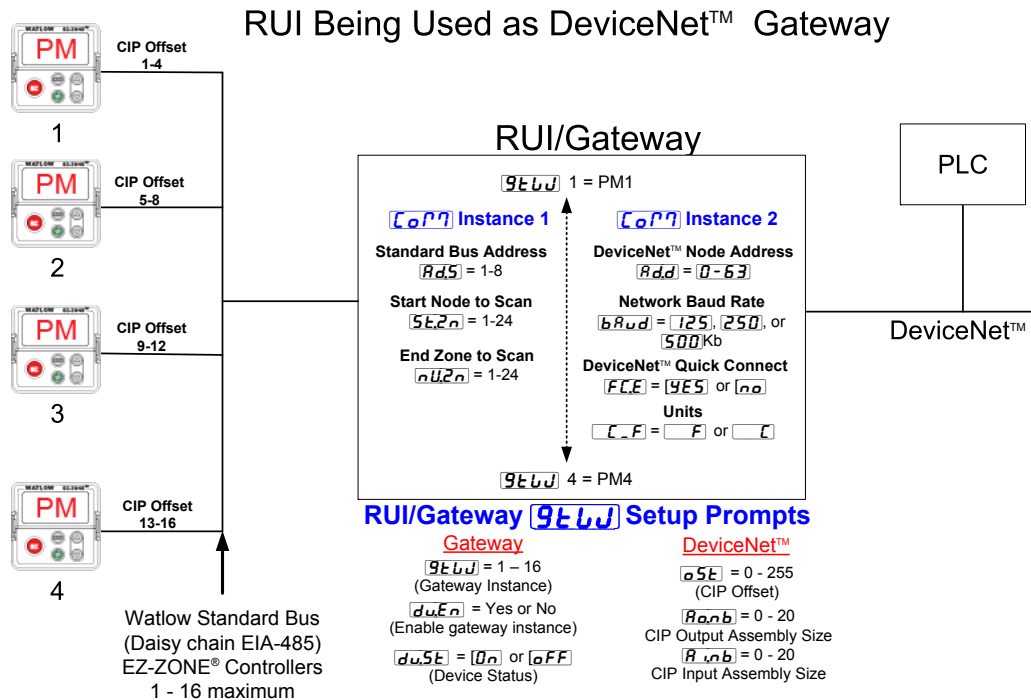

Status are user configurable. The Appendix of this user manual contains the assemblies for each of the EZ-ZONE controllers. (See Appendix: [CIP Implicit Assemblies](#) by product).

To change any given member of either assembly simply write the new class, instance and attribute to the member location of choice. As an example, if it were desired to change the 14th member of the O to T assembly of an EZ-ZONE PM Integrated controller (PM1) from the default parameter (Heat Proportional Band) to Limit Clear Request (see Operations Page,

[oSE] CIP Offset, used exclusively with explicit messaging where it defines a specific gateway instance (EZ_ZONE PM or RM controller) to receive a message originating from the network Master. The CIP offset is unique to each gateway instance and is added to the published instance of any given parameter.

As an example, when programming the explicit message ensure that the class, instance and attribute are defined. To read the first instance of the Process Variable in PM2 (see graphic on next page) use the follow-

ing information in the message instruction:

Class = 104 or (0x68)
 Instance = 1
 Attribute = 1

Note that the instance is identified as instance 1 because there is no offset to add. RUI prompt entry for gateway instance 1 follows:

`o5t` = 0

RUI prompt entry for gateway instance 2 (PM2) follows:

`o5t` = 4

RUI prompt entry for gateway instance 3 follows:

`o5t` = 8

RUI prompt entry for gateway instance 4 follows:

`o5t` = 12

To read the process value instance 2 of PM4 add the offset to the instance. The following information would need to be entered in the message instruction:

Class = 104 or (0x68)
 Instance = 14 or (0x0E)
 Attribute = 1

R o n b From the gateway perspective, this assembly represents data that comes from Standard Bus controllers (EZ-ZONE PM or RM) and is sent out on the network. As seen from the network, this is the CIP Implicit Output Assembly representing inputs to the Master and is used exclusively when communicating implicitly. For any given RUI gateway instance (EZ-ZONE controller), the output assembly size will never be greater than 20, 32-bit members. The user entry ranges from 0 to 20.

R i n b From the gateway perspective, this assembly represents data that comes from the network Master and is sent to one or more gateway instance (EZ-ZONE PM or RM) on Standard Bus. As seen from the network, this is the CIP Implicit Input Assembly representing outputs from the Master and is used exclusively when communicating implicitly. For any given RUI gateway instance (EZ-ZONE controller), the input assembly size will never be greater than 20, 32-bit members. The user entry ranges from 0 to 20.

Note:

The maximum number of implicit input/output members using DeviceNet cannot exceed 200. A network could have up to 10 EZ-ZONE controllers with 20 members each maximum or the 200 members can be divided any way the user would like as long as 20 I/O members per controller are not exceeded.

Using the graphic below as an example, if `9tLJ` instance 1 - 4 has **R o n b** and **R i n b** set to 5, each of the four EZ-ZONE family controllers will contain

the first 5 members of the assembly and this information would then be passed implicitly to the Master on the DeviceNet™ network. The EDS (Electronic Data Sheet) can be found on the CD shipped with the product "Controller Support Tools".

Note:

To minimize traffic and enable better throughput on Standard Bus, set the End Zone prompt `oLzn` in the RUI to the maximum number of EZ-ZONE controllers on the network to be scanned.

DeviceNet RUI/GTW LED Indicators

Viewing the unit from the front and then looking on top of the RUI/GTW two LEDs can be seen aligned vertically front to back. The LED closest to the front is identified as the network (Net) LED where the one next to it would be identified as the module (Mod) LED.

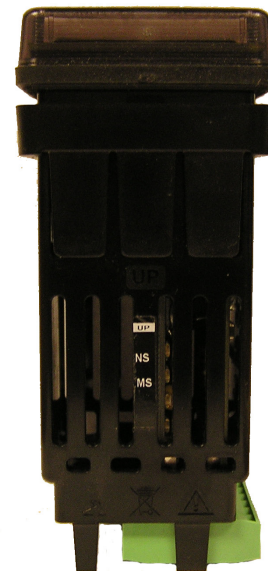

Network Status (NS)

Indicator LED	Description
Off	The device is not online and has not completed the duplicate MAC ID test yet. The device may not be powered.
Green	The device is online and has connections in the established state (allcated to a Master).
Red	Failed communication device. The device has detected an error that has rendered it incapable of communicating on the network (duplicate MAC ID or Bus-off).
Flashing Green	The device is online, but no connection has been allocated or an explicit connection has timed out.
Flashing Red	A poll connection has timed out.

Module Status (MS)

Indicator LED	Description
Off	No power is applied to the device.
Flashing Green-Red	The device is performing a self-test.

Module Status (MS) cont.	
Indicator LED	Description
Flashing Red	Major Recoverable Fault.
Red	Major Unrecoverable Fault.
Green	The device is operating normally.

To learn more about CIP and DeviceNet point your browser to: <http://www.odva.org>

Ethernet Communications

Using EtherNet/IP™

Communications To/From Third Party Device:

When using the EtherNet/IP protocol, there are two methods used in communicating, implicitly and explicitly. Once the gateway instance is enabled there are two prompts that relate directly to these forms of communication.

Use the graphic below in reference to the descriptions that follow below.

Note that the instance is identified as instance 1 because there is no offset to add. RUI prompt entry for gateway instance 1 follows:

`o5t` = 0

RUI prompt entry for gateway instance 2 (PM2) follows:

`o5t` = 4

RUI prompt entry for gateway instance 3 follows:

`o5t` = 8

RUI prompt entry for gateway instance 4 follows:

`o5t` = 12

To read the process value instance 2 of PM4 add the offset to the instance. The following information would need to be entered in the message instruction:

Class = 104 or (0x68)
 Instance = 14 or (0x0E)
 Attribute = 1

`Ranb` From the gateway perspective, this assembly represents data that comes from Standard Bus controllers (EZ-ZONE PM or RM) and

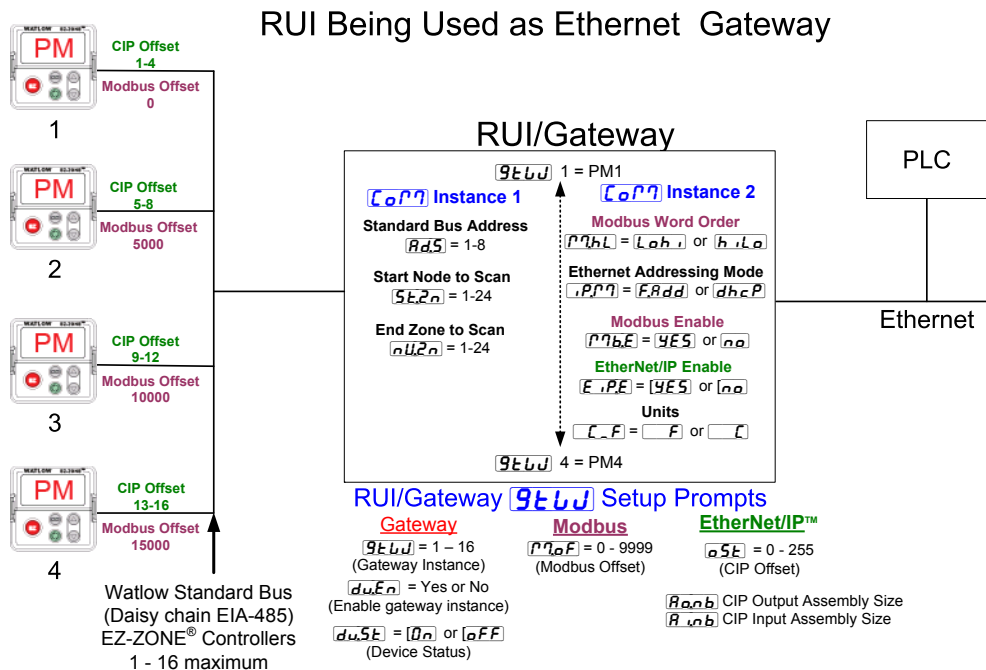

`o5t` CIP Offset, used exclusively with explicit messaging where it defines a specific gateway instance (EZ_ZONE PM or RM controller) to receive a message originating from the network Master. The CIP offset is unique to each gateway instance and is added to the published instance of any given parameter.

As an example, when programming an explicit message ensure that the class, instance and attribute is defined. To read the first instance of the Process Variable in PM2 use the following information in the message instruction:

Class = 104 or (0x68)
 Instance = 1
 Attribute = 1

is sent out on the network. As seen from the network, this is the CIP Implicit Output Assembly representing inputs to the Master and is used exclusively when communicating implicitly. For any given RUI gateway instance (EZ_ZONE controller), the output assembly size will never be greater than 20, 32-bit members. The user entry ranges from 0 to 20.

`Rinb` From the gateway perspective, this assembly represents data that comes from the network Master and is sent to one or more gateway instance (EZ_ZONE PM or RM) on Standard Bus. As seen from the network, this is the CIP Implicit Input Assembly representing

outputs from the Master and is used exclusively when communicating implicitly. For any given RUI gateway instance (EZ-ZONE controller), the input assembly size will never be greater than 20, 32-bit members. The user entry ranges from 0 to 20.

Note:

The maximum number of implicit input/output members using EtherNet/IP cannot exceed 100. A network could have up to 5 EZ-ZONE controllers with 20 members each maximum or the 100 members can be divided any way the user would like as long as 20 I/O members per controller are not exceeded.

Using the graphic on the following page as an example, if:

- 9E6U instance 1 has R,rb and R,rb set to 5
- 9E6U instance 2 has R,rb and R,rb set to 5
- 9E6U instance 3 has R,rb and R,rb set to 5
- 9E6U instance 4 has R,rb and R,rb set to 5

Each of the four EZ-ZONE family controllers will contain the first 5 members of the assembly and this information would then be passed implicitly to the Master on the EtherNet/IP network.

Using Modbus TCP

Communications To/From a Master:

When Modbus TCP is enabled there are Modbus related prompts (violet as shown in graphic) that need to be addressed. They are:

1. Modbus TCP Enable [P7bE], turns Modbus on or off.
2. Modbus TCP Word Order [P7hL], which allows the user to swap the high and low order 16 bit values of a 32-bit member.
3. Modbus TCP Offset [P7oF], which defines each of the available Modbus registers for each gateway instance.

As an example, when using Modbus TCP notice that the Modbus offset now applies. For the purpose of this discussion assume the offsets are as shown in the graphic on the following page and the Master wants to read the first instance of Closed Loop Set Point from both Standard Bus address 1 and 4. Open up the appropriate PM users manual and go to the Operations Page, Loop Menu to find the Closed Loop Set Point.

Note:

If using a legacy EZ-ZONE ST controller with a firmware version less the 3.0, consider using the Modbus addresses listed in the ST user manual in the column entitled "RUI/GTW Modbus". If the firmware in the ST is 3.0 or higher new features were added and made accessible through the Map2 registers. If interested in using the new features today or perhaps in the future configure the ST for

Map 2 Modbus registers.

When found, notice that the relative Modbus register is 2160 (Map 1) or 2640 (Map 2). To read the set point from address 1 the appropriate absolute Modbus address would be:

$$2160 + 400001 + \text{Modbus offset (0)} = 402161.$$

To read the Closed Loop Set Point from Standard Bus address 4 the absolute address would be:

$$2160 + 400001 + \text{Modbus offset (15000)} = 417161.$$

Note:

To minimize traffic and enable better throughput on Standard Bus, set the End Zone prompt [nU2n] in the RUI to the maximum number of EZ-ZONE controllers on the network to be scanned.

Note:

The RUI/GTW allows for a maximum entry of 9999 due to limitations of the 7 segment display. To enter a Modbus offset > 9999 EZ-ZONE Configurator must be used..

Note:

In the above graphic there are several prompts omitted for the sake of saving some space. When the Ethernet addressing mode is set to Fixed the user will find several more prompts that will follow the prompt shown for "Ethernet Addressing Mode" related to specifying the actual IP [P.F1] - [P.F4], subnet [P.S1] - [P.S4] and the gateway [P.G1] - [P.G4] (external gateway) addresses. If set to receive an IP address from a host [dHCP] computer, the prompts shown above are accurate.

Note:

When changing the RUI/GTW IP address, power must be cycled for the new address to take effect.

Ethernet RUI/GTW LED Indicators

Viewing the unit from the front and then looking on top of the RUI/GTW four LEDs can be seen aligned vertically front to back. The LEDs are identified accordingly: closest to the front reflects the Network (Net) status, Module (Mod) status is next, Activity status follows and lastly, the LED closest to the rear of the RUI/GTW reflects the Link status.



Network Status

Indicator State	Summary	Requirement
Steady Off	Not powered, no IP address	If the device does not have an IP address (or is powered off), the network status indicator shall be steady off.
Flashing Green	No connections	If the device has no established connections, but has obtained an IP address, the network status indicator shall be flashing green.
Steady Green	Connected	If the device has at least one established connection (even to the Message Router), the network status indicator shall be steady green.
Flashing Red	Connection timeout	If one or more of the connections in which this device is the target has timed out, the network status indicator shall be flashing red. This shall be left only if all timed out connections are reestablished or if the device is reset.
Steady Red	Duplicate IP	If the device has detected that its IP address is already in use, the network status indicator shall be steady red.
Flashing Green / Red	Self-test	While the device is performing its power up testing, the network status indicator shall be flashing green / red.

Module Status

Indicator State	Summary	Requirement
Steady Off	No power	If no power is supplied to the device, the module status indicator shall be steady off.
Steady Green	Device operational	If the device is operating correctly, the module status indicator shall be steady green.
Flashing Green	Standby	If the device has not been configured, the module status indicator shall be flashing green.
Flashing Red	Minor fault	If the device has detected a recoverable minor fault, the module status indicator shall be flashing red. NOTE: An incorrect or inconsistent configuration would be considered a minor fault.

Module Status (cont.)		
Indicator State	Summary	Requirement
Steady Red	Major fault	If the device has detected a non-recoverable major fault, the module status indicator shall be steady red.
Flashing Green / Red	Self-test	While the device is performing its power up testing, the module status indicator shall be flashing green / red.

Link Status

Indicator State	Summary	Requirement
Steady Off	Not powered, unknown link speed	If the device cannot determine link speed or power is off, the network status indicator shall be steady off.
Red	Link speed = 10 Mbit	If the device is communicating at 10 Mbit, the link LED will be red..
Green	Link speed = 100 Mbit	If the device is communicating at 100 Mbit, the link LED will be green.

Activity Status

Indicator State	Summary	Requirement
Flashing Green	Detects activity	If the MAC detects activity, the LED will be flashing green.
Red	Link speed = 10Mbit	If the MAC detects a collision, the LED will be red.

Using Profibus DP

Communications To/From Third Party Device:

The RUI/GTW equipped with the Profibus DP protocol supports cyclic (DP-V0) and acyclic (DP-V1) communications. For your reference, cyclic communications implies that a set of defined parameters (user configured as it relates to the RUI/GTW) are periodically read and or written. The frequency or period of the read/write operations is determined (setup) via the Master on the network. You can configure the cyclic parameter set by installing the software (Profibus GSD Editor for EZ-ZONE Products) which can be found on the CD that came with the product (Controller Support Tools) or by clicking on the link below where it can be downloaded free of charge. Once the GSD (Generic Station Description) file is created, simply upload it to the Master device.

http://www.watlow.com/literature/pti_search.cfm?dltype=4

Acyclic communications will read and or write data on demand and is based on the Slot Offset and the specific index for any given parameter. Most of the discussion that follows is related to acyclic communications.

As with all of the other available protocols prior to establishing communications between Master and the slave the gateway instance must first be enabled

Slot Offset = 61
Index = 0

RUI Being Used as Profibus DP Gateway

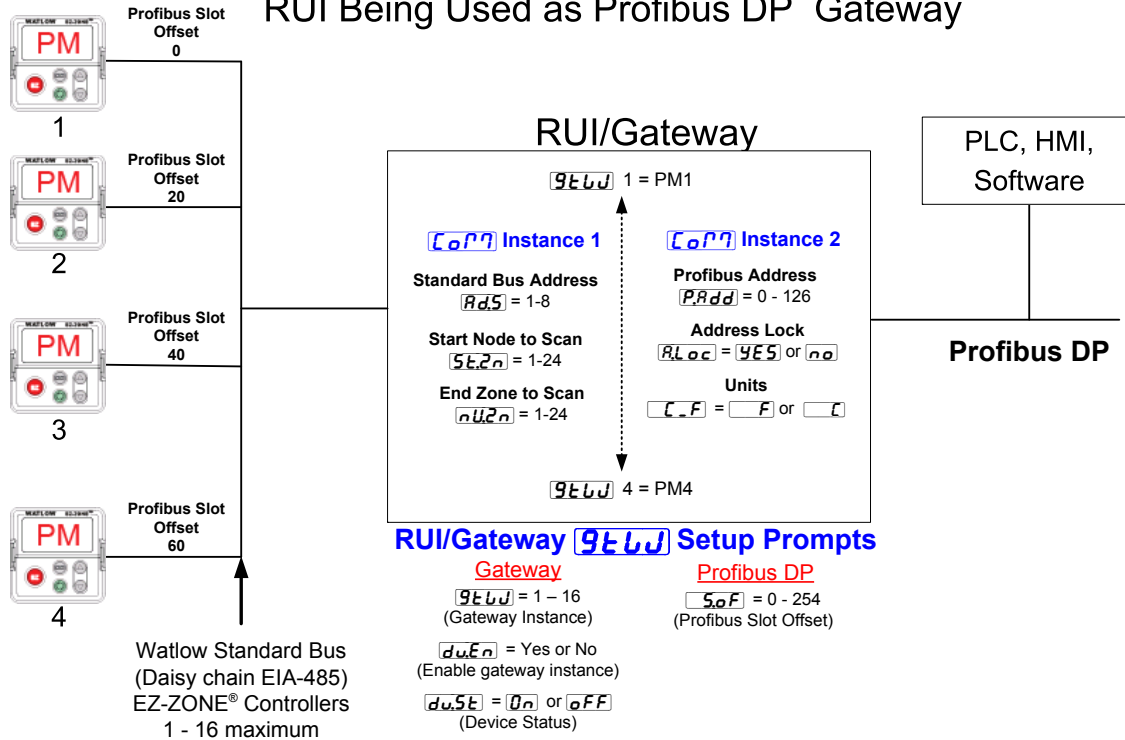

$[d_{uEn}]$. Once enabled, the user must define the Slot Offsets for each enabled EZ-ZONE controller.

Use the graphic below (RUI being used as a Profibus DP Gateway) in reference to the descriptions that follow below.

$[S_{oF}]$ Slot Offsets are used exclusively with acyclic (DP-V1) communications and define the individual EZ-ZONE controller on the network as well as the instance of the parameter to be read or written to. The offset defaults are as shown in the graphic in increments of 20, however, they can be changed based on user needs.

As an example, when programming the Master device ensure that the Slot Offset and the Profibus Index (found in each product user manual in the various menus) are defined. To read the first instance of the Process Value in PM2 use the following information when programming the Master:

Slot Offset = 20
Index = 0 (See the EZ-ZONE PM Users Manual, Operations Page under the Analog Input Menu)

Note that PM2 and instance 1 is identified in the Slot Offset where the parameter, in this case, Process Value 1 is identified via the Profibus Index. If it were instance 2 same parameter that was needed the Slot Offset would change to 21.

Likewise, to read the Process Value instance 2 of PM4 the following information would need to be entered when programming the Master:

Profibus DP RUI/GTW LED Indicators

Viewing the unit from the front and then looking on top of the RUI/GTW two bi-color LEDs can be seen where only the front one is used. Definition follows:

Closest to the Front

Indicator LED	Description
Red	Profibus network not detected
Red Flashing	Indicates that the Profibus card is waiting for data exchange.
Green	Data exchange mode

To learn more about Profibus DP point your browser to: <http://www.profibus.org>

Software Configuration

Using EZ-ZONE® Configurator Software

To enable a user to configure the RUI/GTW using a personal computer (PC), Watlow has provided free software for your use. If you have not yet obtained a copy of this software insert the DVD that came with the product (Controller Support Tools) into your CD/DVD drive and install the software. Alternatively, if you are viewing this document electronically and have a connection to the internet simply click on the link below and download the software from the Watlow web site free of charge.

http://www.watlow.com/products/software/zone_config.cfm

Once the software is installed, double click on the EZ-ZONE Configurator icon placed on your desktop during the installation process. If you cannot find the icon follow the steps below to run the software:

1. Move your mouse to the "Start" button
2. Place the mouse over "All Programs"
3. Navigate to the "Watlow" folder and then the sub-folder "EZ-ZONE Configurator"
4. Click on EZ-ZONE Configurator to run.

The first screen that will appear is shown below.

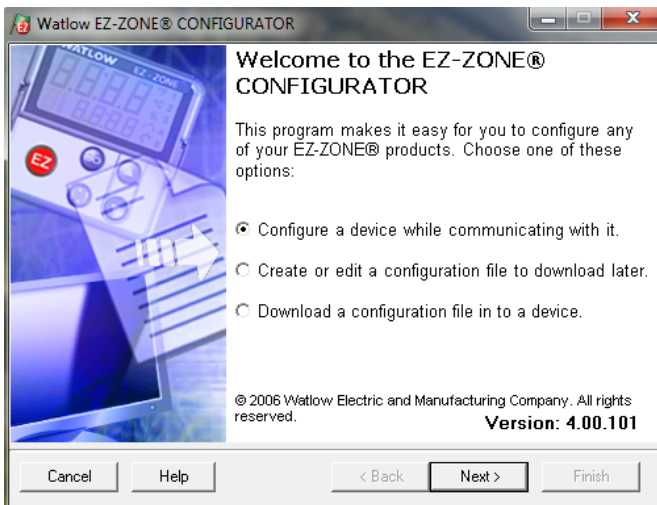

If the PC is already physically connected to the EZ-ZONE RUI/GTW click the next button to go on-line.

Note:

When establishing communications from PC to the EZ-ZONE RUI/GTW an interface converter will be required. The Standard Bus network uses EIA-485 as the interface. Most PCs today would require a USB to EIA-485 converter (consider Watlow Part # 0847-0326-0000). However, some PCs may still be equipped with EIA-232 ports, therefore an EIA-232 to EIA-485 converter would be required.

As can be seen in the above screen shot the software provides the user with the option of downloading a previously saved configuration as well as the ability to create a configuration off-line to download later. The screen shots that follow will take the user on-line.

After clicking the next button it is necessary to define which communications port the PC will use. Clicking on the drop down (orange circle below) will show all available communication ports.

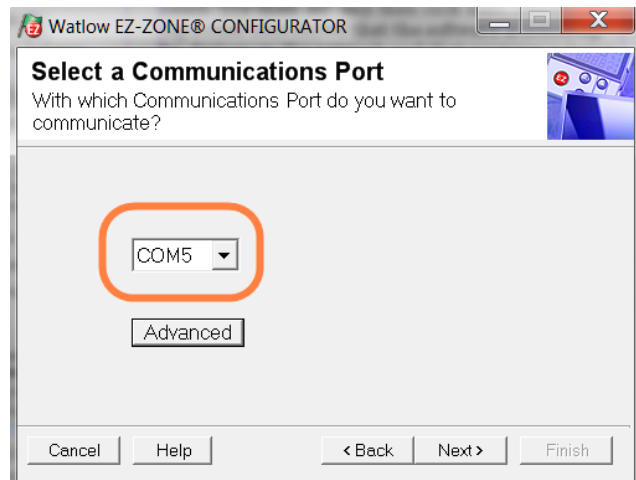

The "Advanced" button allows the user to specify how many controller zones (1 - 17) to look for when scanning as well as whether or not to scan for RUI/GTWs. If it is desired to connect and configure the RUI/GTW, ensure that "Also scan for Remote Users Interfaces" is checked as shown in the graphic below.

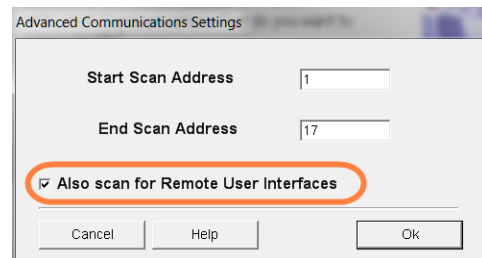

The following screen shot shows that the software is scanning for devices on the network and that progress is being made.

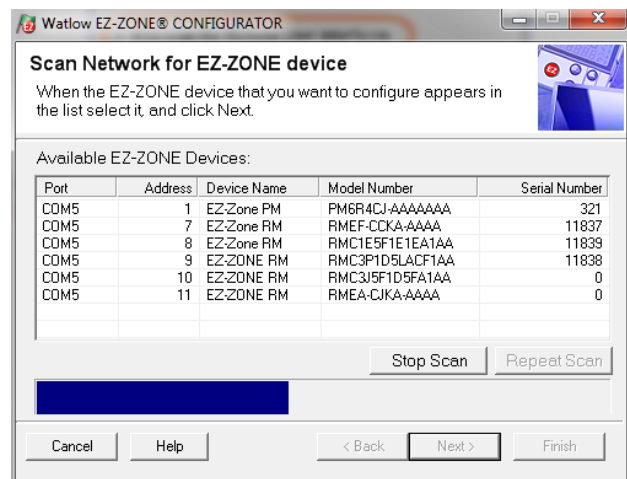

When complete the software will display all of the available devices found on the network as shown in the graphic below.

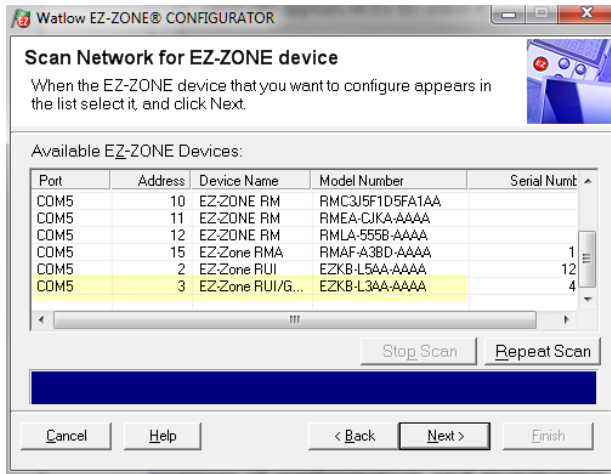

In the screen shot above the RUI/GTW is shown highlighted to bring greater clarity to the subject in focus. Any EZ-ZONE device on the network will appear in this window and would be available for the purpose of configuration and monitoring. After clicking on the RUI/GTW simply click the next button once again where the screen below will appear.

The menu structure as laid out within this software follows:

- Communications
- Global
- Local Remote Gateway
- Lock
- Diagnostics

Navigating through this software and acquiring a better understanding of the available options is easy. Simply slide the scroll bar up or down to display the menu and parameter of choice. As an alternative, menus can be collapsed for greater focus on the menu of choice and or expanded for a broader view of all menus by clicking on the plus or negative symbol next to menu name. Once the focus is brought to an individual parameter of choice (single click of mouse) as shown below for Local Remote Gateway 1, all that can be setup related to that parameter will appear in the center column along with context sensitive help in the right hand column. If a parameter is grayed out (not selectable) as shown in the center column below, that function is either not enabled or it does not apply.

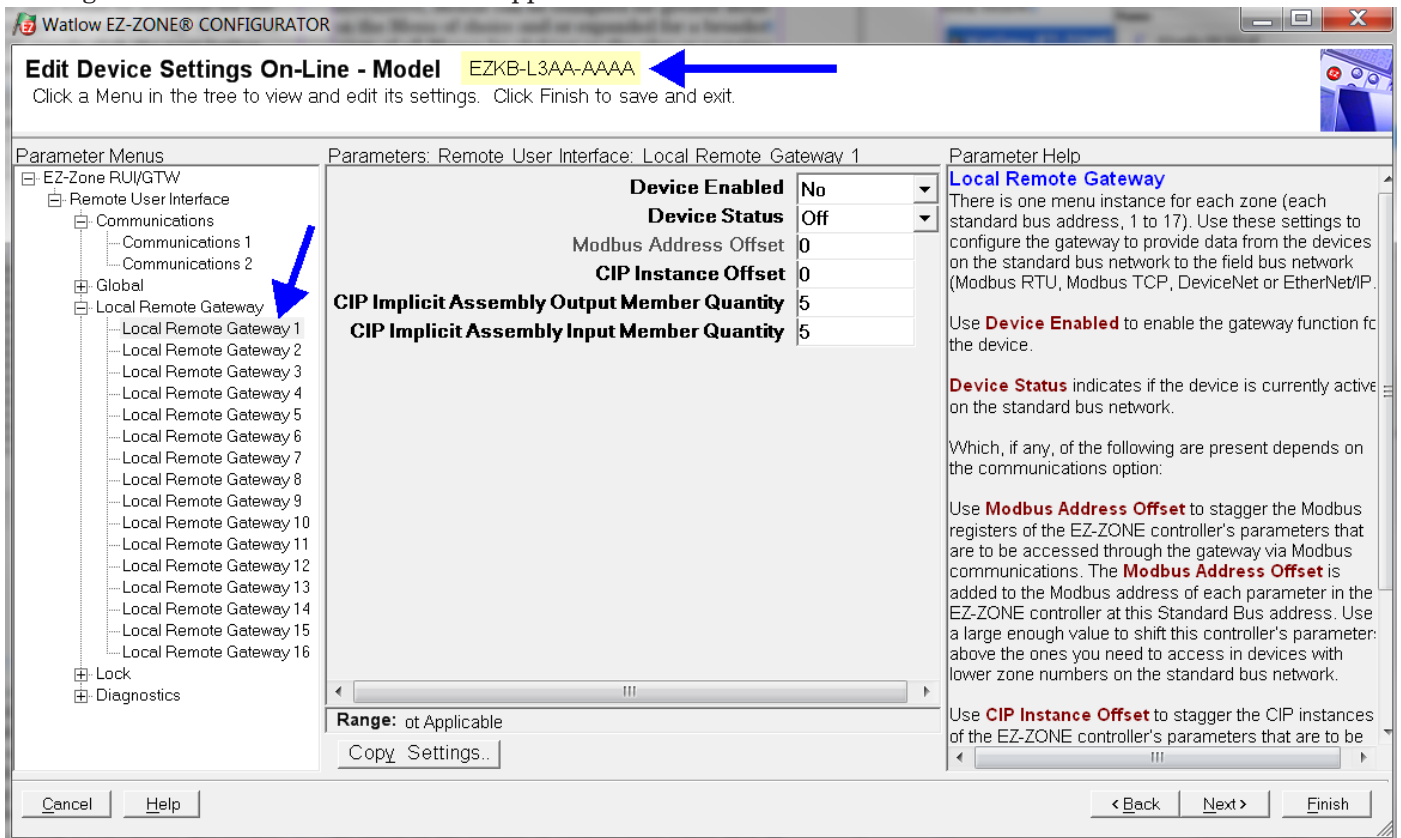

Notice in the screen shot above that the device part number is clearly displayed at the top of the page (yellow highlight added for emphasis). When multiple EZ-ZONE devices are on the network it is important that the part number be noted prior to configuring so as to avoid making unwanted configuration changes to another controller.

Looking closely at the left hand column (Parameter Menus) notice that it displays all of the available menus and associated parameters within the gateway

To speed up the process of configuration notice that at the bottom of the center column there is an option to copy settings. If gateway settings are the same for all instances click on "Copy Settings" where a copy from to copy to dialog box will appear allowing for quick duplication of all settings.

Once the configuration is complete click the "Finish" button at the bottom right of the screen above. The screen that follows this action can be seen below.

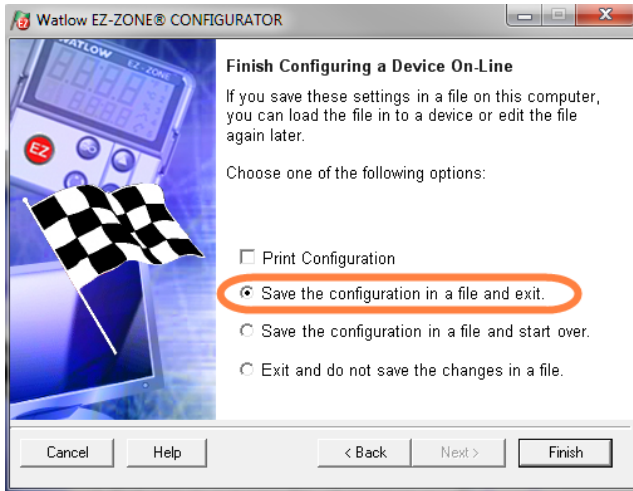

Although the RUI/GTW now contains the configuration (because this entire discussion focused on doing the configuration on-line) it is suggested that after the configuration process is completed that the user save this file to the PC for future use. If for some reason someone inadvertently changed a setting without understanding the impact, it would be easy and perhaps faster to download a saved configuration back to the RUI/GTW versus trying to figure out what was changed. There is also an option to exit without saving a copy to the local hard drive.

After selecting Save above, click the "Finish" button once again. The screen below will then appear.

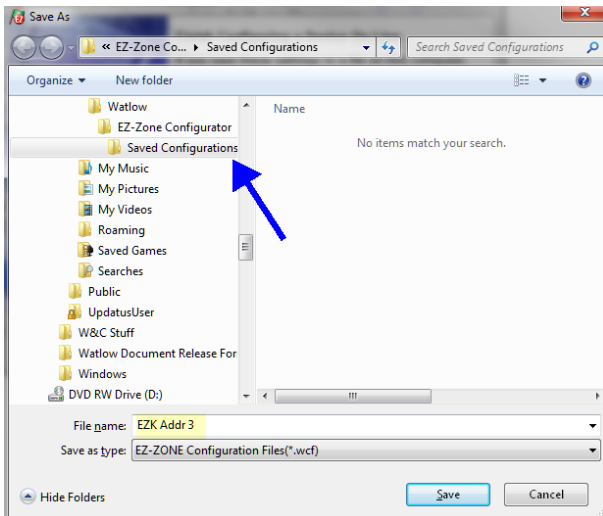

When saving the configuration note the location where the file will be placed (arrow) and enter the file name (File name, yellow highlight) as well. The default path for saved files follows:

```
\My Documents\Watlow\EZ-ZONE CONFIGURATOR\Saved Configurations
```

The user can save the file to any folder of choice.

Saving Settings to Non-volatile Memory

When save to EEPROM is enabled, values are saved once every five seconds if a value written has changed. If the EEPROM is disabled, any changes from the keypad that cause a change in the controller will initiate a save of all values.

If controller settings are entered from the front panel (PM) or via an RUI, changes are always saved to non-volatile memory (EEPROM) in the controller (RM, PM or ST). If the controller loses power or is switched off, its settings will be restored when power is reapplied.

The EEPROM will wear out after about 1,000,000 writes, which should not be a problem with changes made from the panel or RUI. However, if the controller is receiving data from a Master device on a network such as a PLC via the gateway, the EEPROM could over time, wear out.

By default, settings made over Standard Bus (Com instance 1) via the gateway or front panel of the RUI are saved to EEPROM. Whenever new information is sent from these devices, e.g., new set point, new control mode, etc... a write to EEPROM will occur. No further writes to EEPROM will occur until the input data changes again. This would be true over a network (Com instance 2) as well. If the data is changing it will be written to the EEPROM. If it is desired to inhibit writes to the EEPROM over a network, write the value of 59 to the addresses in the controllers specified below.

Note:

This is an individual operation on each EZ-ZONE controller on the Standard Bus side of the network.

CIP (DeviceNet and EtherNet/IP) by Controller Type

For the following controllers:

RMC, RMS, RML, RMH, ST and PM-PID

Class = 150

Instance = 1

Attribute = 8

RMA

Class = 150

Instance = 2

Attribute = 8

PMI and PML

Class = 150 Class = 150

Instance = 1 Instance = 2

Attribute = 8 Attribute = 8

Modbus Registers by Controller Type

PMI and PML

Instance 1 Instance 2

Map 1 = 2494 Map 1 = 2514

Map 2 = 2974 Map 2 = 2994

PID

Instance 1

Map 1 = 2494

Map 2 = 2974

ST

Map 1 = 317

Map 2 = 2064

RMC	RMA	RMS	RML	RMH
2834	444	3474	3504	6514

Profibus by Controller Type

RMC, RML, RMH, PML, PMI and PID

198

RMS

112

RMA

82

Enumerated values for this member follows:

Yes = 106 (allow writes to EEPROM), No = 59 (Disable writes to EEPROM)

Note:

Some controllers have only 1 communications port where this discussion would apply if connected to an RUI/GTW or RMA module. Other controls like the PMI and the PML can have 2 communications ports therefore you will find 2 instances. This setting relates to the controller the RUI/GTW is connected to, not the RUI/GTW itself. Everything changed in the RUI/GTW, either via EZ-ZONE Configurator software or from the front panel will be saved to the EEPROM in the RUI/GTW.

6

Chapter 6: Appendix

Troubleshooting

Indication	Description	Possible Cause(s)	Corrective Action
No Display	No display indication or LED illumination	<ul style="list-style-type: none"> • Power to RUI (Remote User Interface) is off • Fuse open • Breaker tripped • Safety interlock switch open • Separate system limit controller activated • Wiring error • Incorrect voltage to controller 	<ul style="list-style-type: none"> • Turn on power. • Replace fuse. • Reset breaker. • Close interlock switch. • Reset limit. • Correct wiring issue. • Apply correct voltage.
EZ-Key doesn't work	EZ-Key does not activate required function	<ul style="list-style-type: none"> • Keypad malfunction 	<ul style="list-style-type: none"> • Replace or repair the RUI.
<div style="border: 1px solid black; padding: 2px; display: inline-block;">na</div> upper display <div style="border: 1px solid black; padding: 2px; display: inline-block;">dEu</div> lower display	The RUI (Remote User Interface) will not communicate with the controller at the selected zone.	<ul style="list-style-type: none"> • Communications wired incorrectly • Communications wires routed with power wires • Zone address set out of range • RUI or controller defective 	<ul style="list-style-type: none"> • Check and correct wiring. • Check and correct wiring. • Check zone range and address. • Replace or repair RUI or controller.
<div style="border: 1px solid black; padding: 2px; display: inline-block;">uRL.h</div>	Value is too large to be displayed (≥ 1000.0).	<ul style="list-style-type: none"> • Scaling is out of range 	<ul style="list-style-type: none"> • Check scaling. • Call technical support.
<div style="border: 1px solid black; padding: 2px; display: inline-block;">uRL.L</div>	Value is too small to be displayed (≤ -2000.0).	<ul style="list-style-type: none"> • Scaling is out of range 	<ul style="list-style-type: none"> • Check scaling. • Call technical support.

Modbus - Programmable Memory Blocks

PM Modbus Assembly Definition

Assembly Definition Addresses	Assembly Working Addresses	Assembly Definition Addresses	Assembly Working Addresses
40 & 41	200 & 201	80 & 81	240 & 241
42 & 43	202 & 203	82 & 83	242 & 243
44 & 45	204 & 205	84 & 85	244 & 245
46 & 47	206 & 207	86 & 87	246 & 247
48 & 49	208 & 209	88 & 89	248 & 249
50 & 51	210 & 211	90 & 91	250 & 251
52 & 53	212 & 213	92 & 93	252 & 253
54 & 55	214 & 215	94 & 95	254 & 255
56 & 57	216 & 217	96 & 97	256 & 257
58 & 59	218 & 219	98 & 99	258 & 259
60 & 61	220 & 221	100 & 101	260 & 261
62 & 63	222 & 223	102 & 103	262 & 263
64 & 65	224 & 225	104 & 105	264 & 265
66 & 67	226 & 227	106 & 107	266 & 267
68 & 69	228 & 229	108 & 109	268 & 269
70 & 71	230 & 231	110 & 111	270 & 271
72 & 73	232 & 233	112 & 113	272 & 273
74 & 75	234 & 235	114 & 115	274 & 275
76 & 77	236 & 237	116 & 117	276 & 277
78 & 79	238 & 239	118 & 119	278 & 279

PM Modbus Default Assembly Structure 40-79

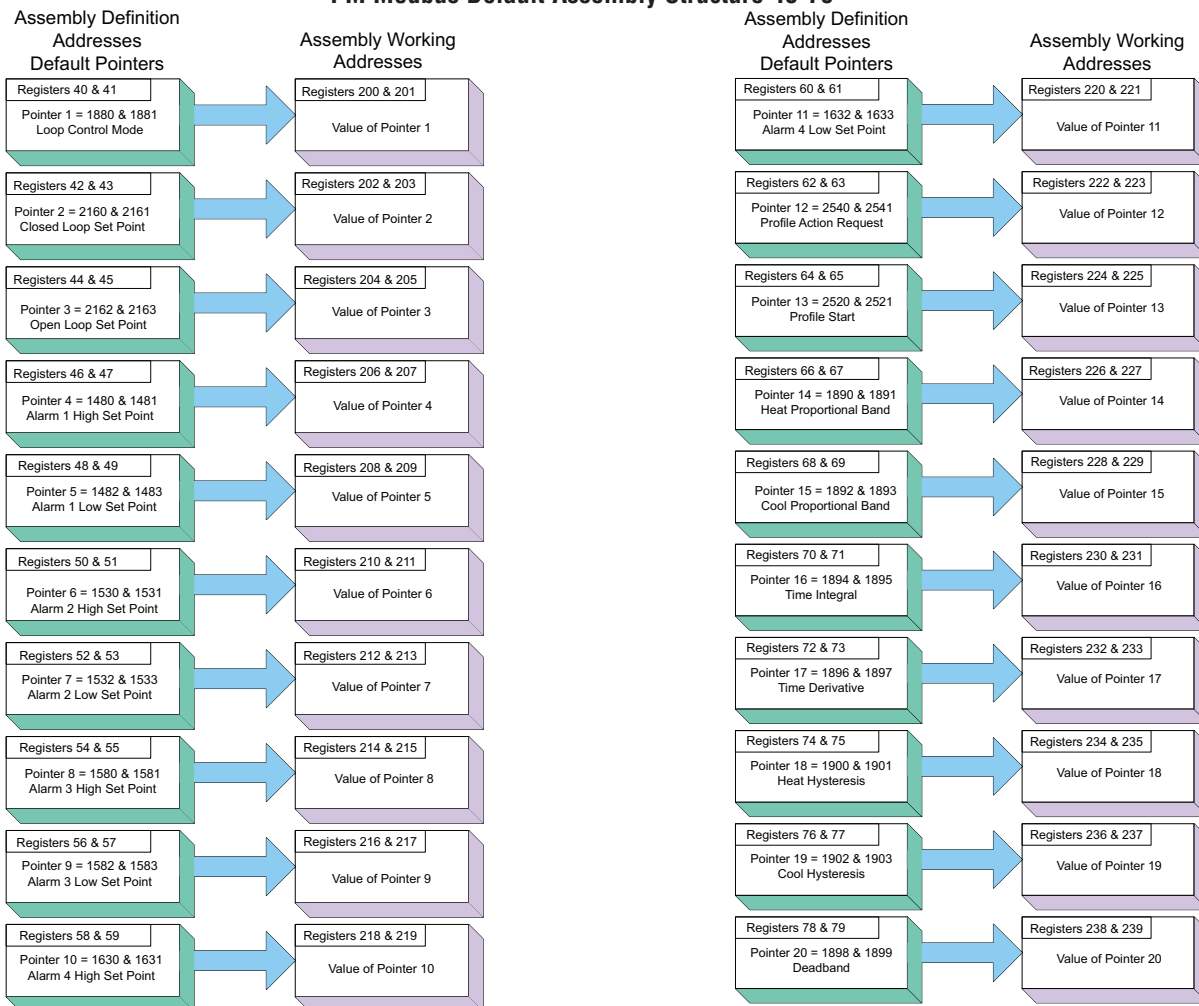

PM Modbus Default Assembly Structure 80-119

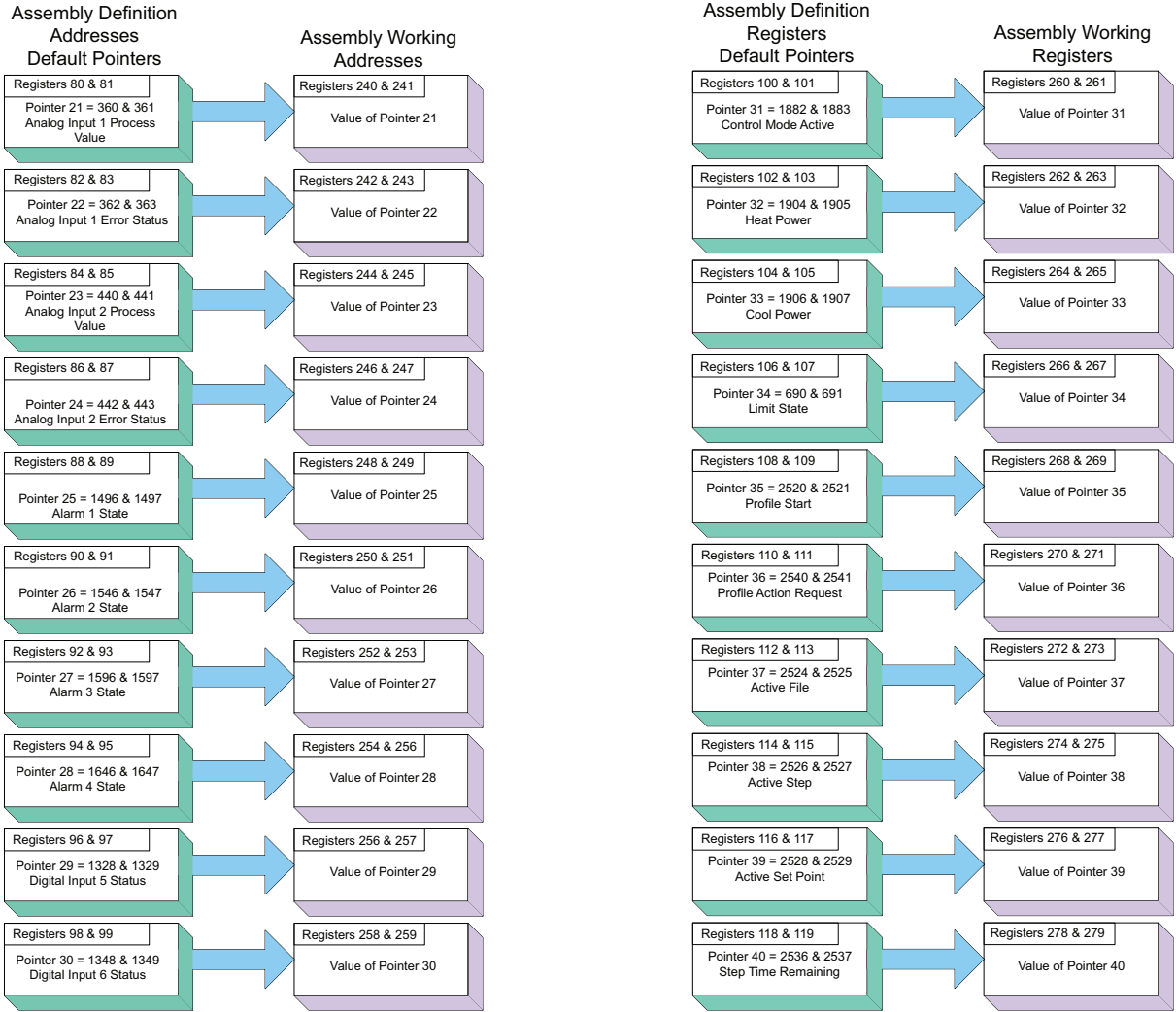

RM Modbus Assembly Definition

Assembly Definition Address and Assembly Working Addresses

Definition Addresses	Working Addresses		Definition Addresses	Working Addresses
40 & 41	200 & 201		120 & 121	280 & 281
42 & 43	202 & 203		122 & 123	282 & 283
44 & 45	204 & 205		124 & 125	284 & 285
46 & 47	206 & 207		126 & 127	286 & 287
48 & 49	208 & 209		128 & 129	288 & 289
50 & 51	210 & 211		130 & 131	290 & 291
52 & 53	212 & 213		132 & 133	292 & 293
54 & 55	214 & 215		134 & 135	294 & 295
56 & 57	216 & 217		136 & 137	296 & 297
58 & 59	218 & 219		138 & 139	296 & 299
60 & 61	220 & 221		140 & 141	300 & 301
62 & 63	222 & 223		142 & 143	302 & 303
64 & 65	224 & 225		144 & 145	304 & 305
66 & 67	226 & 227		146 & 147	306 & 307
68 & 69	228 & 229		148 & 149	308 & 309
70 & 71	230 & 231		150 & 151	310 & 311
72 & 73	232 & 233		152 & 153	312 & 313
74 & 75	234 & 235		154 & 155	314 & 315
76 & 77	236 & 237		156 & 157	316 & 317
78 & 79	238 & 239		158 & 159	318 & 319
80 & 81	240 & 241		160 & 161	320 & 321
82 & 83	242 & 243		162 & 163	322 & 323
84 & 85	244 & 245		164 & 165	324 & 325
86 & 87	246 & 247		166 & 167	326 & 327
88 & 89	248 & 249		168 & 169	328 & 329
90 & 91	250 & 251		170 & 171	330 & 331
92 & 93	252 & 253		172 & 173	332 & 333
94 & 95	254 & 255		174 & 175	334 & 335
96 & 97	256 & 257		176 & 177	336 & 337
98 & 99	256 & 259		178 & 179	338 & 339
100 & 101	260 & 261		180 & 181	340 & 341
102 & 103	262 & 263		182 & 183	342 & 343
104 & 105	264 & 265		184 & 185	344 & 345
106 & 107	266 & 267		186 & 187	346 & 347
108 & 109	268 & 269		188 & 189	348 & 349
110 & 111	270 & 271		190 & 191	350 & 351
112 & 113	272 & 273		192 & 193	352 & 353
114 & 115	274 & 275		194 & 195	354 & 355
116 & 117	276 & 277		196 & 197	356 & 357
118 & 119	278 & 279		198 & 199	358 & 359

Note:

Notice that in the Modbus tables that follow the first 40 members have predefined definitions from the factory. These members reflect the assembly of the RMC module only. All other RM module assemblies are undefined as delivered from the factory; if the undefined members are to be used, they must be configured by the user

RM Modbus Default Assembly Structure 40-119

Assembly Definition Addresses Default Pointers

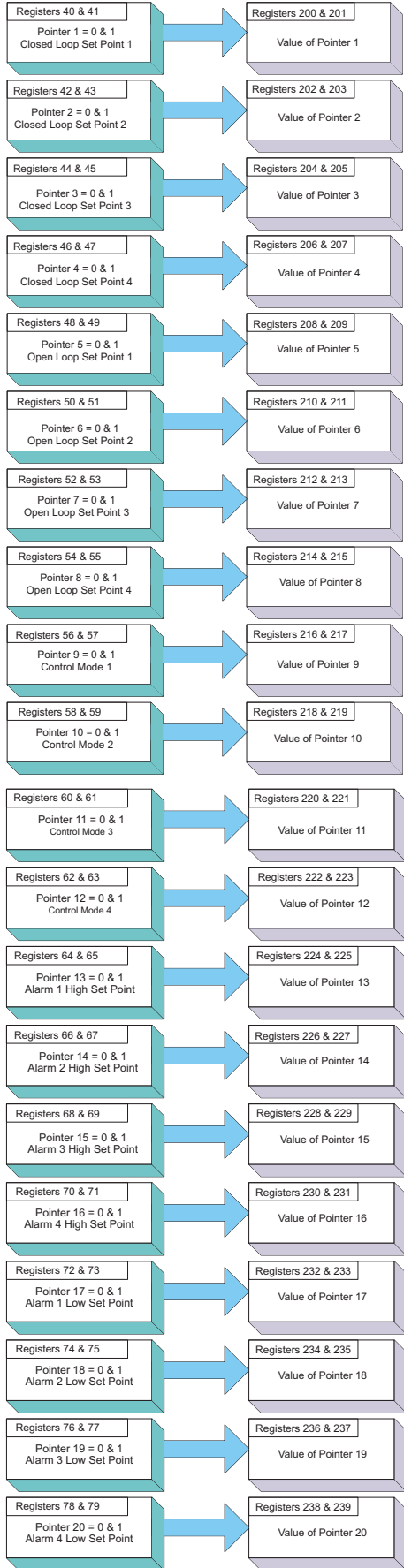

Assembly Definition Addresses Default Pointers

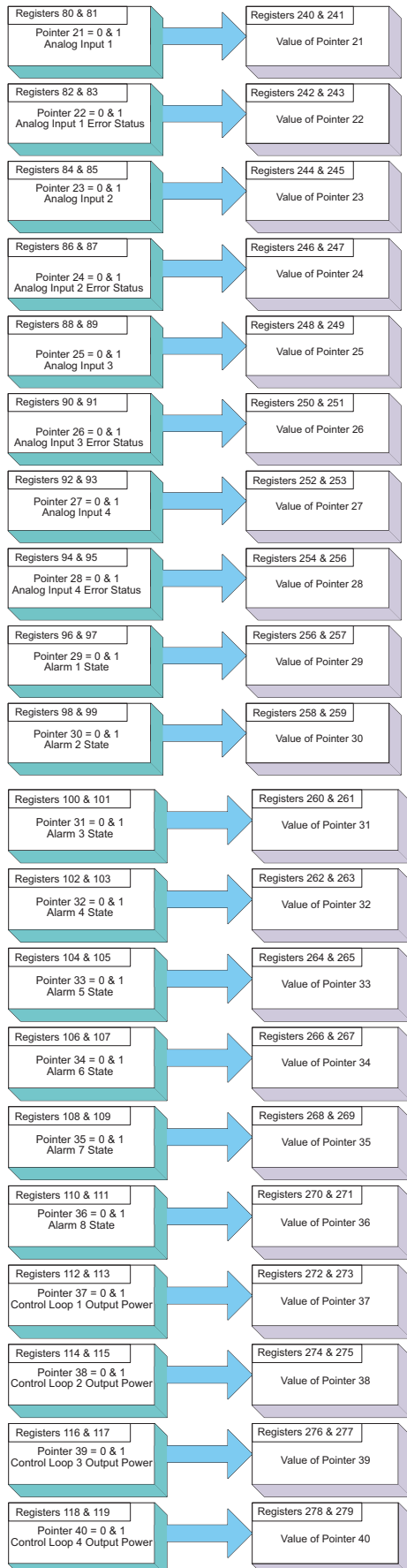

RM Modbus Default Assembly Structure 120 - 199

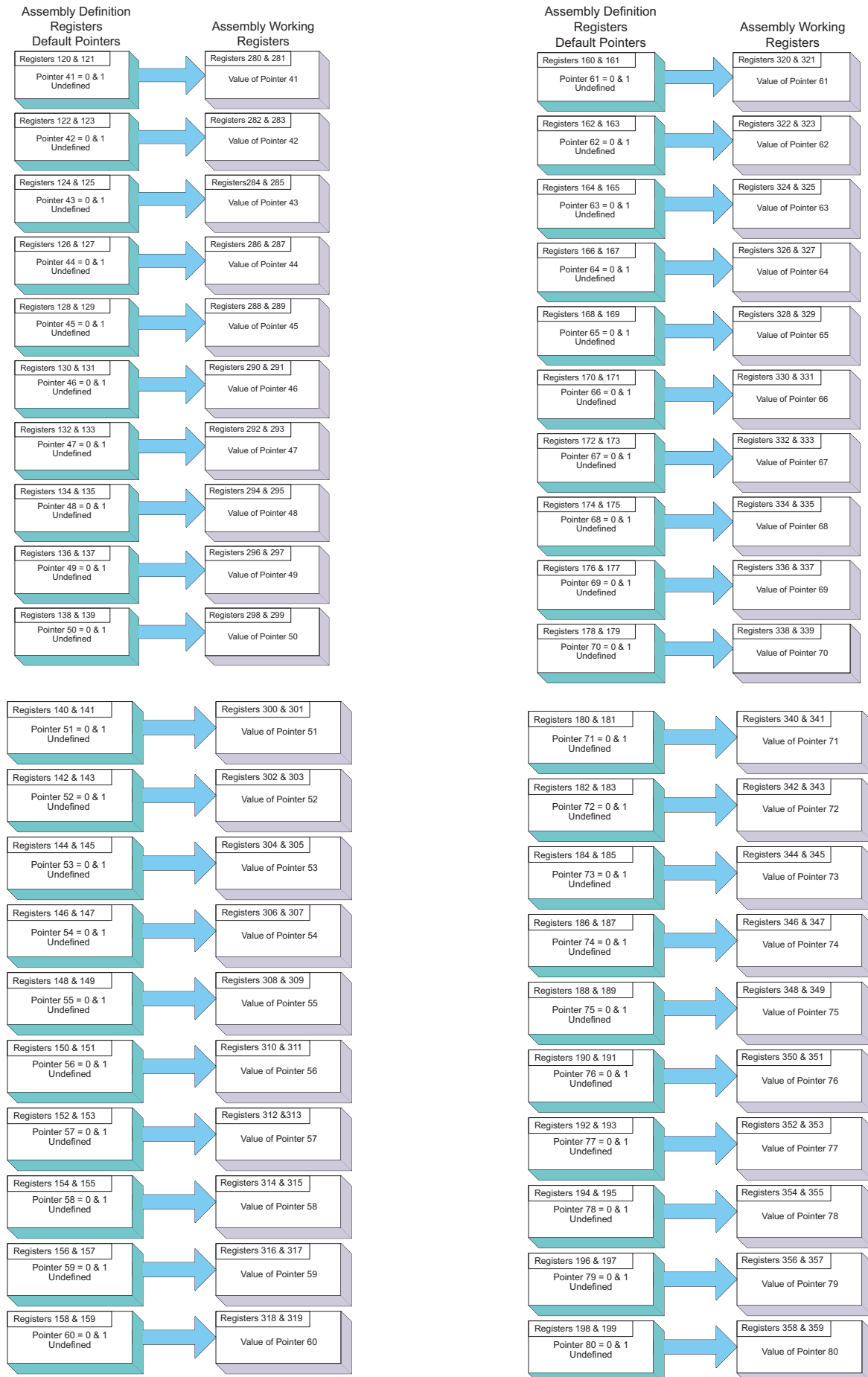

CIP Implicit Assemblies

ST CIP Implicit Assemblies

CIP Implicit Assembly Originator (Master) to Target (ST)					
Assembly Members	Assembly Class, Instance, Attribute	ST Data Type	Parameter	Parameter Class, Instance, Attribute	PLC Data Type
1	0x77, 0x01, 0x01	DINT	Control Loop 1, User Control Mode	0x97, 0x01, 0x01	DINT
2	0x77, 0x01, 0x02	DINT	Closed Loop Set Point	0x6B, 0x01, 0x01	REAL
3	0x77, 0x01, 0x03	DINT	Open Loop Set Point	0x6B, 0x01, 0x02	REAL
4	0x77, 0x01, 0x04	DINT	Alarm 1 - Alarm High Set Point	0x6D, 0x01, 0x01	REAL
5	0x77, 0x01, 0x05	DINT	Alarm 1 - Alarm Low Set Point	0x6D, 0x01, 0x02	REAL
6	0x77, 0x01, 0x06	DINT	Alarm 2 - Alarm High Set Point	0x6D, 0x01, 0x01	REAL
7	0x77, 0x01, 0x07	DINT	Alarm 2 - Alarm Low Set Point	0x6D, 0x02, 0x02	REAL
8	0x77, 0x01, 0x08	DINT	Alarm 3 - Alarm High Set Point	0x6D, 0x03, 0x01	REAL
9	0x77, 0x01, 0x09	DINT	Alarm 3 - Alarm Low Set Point	0x6D, 0x03, 0x02	REAL
10	0x77, 0x01, 0x0A	DINT	Alarm 4 - Alarm High Set Point	0x6D, 0x04, 0x01	REAL
11	0x77, 0x01, 0x0B	DINT	Alarm 4 - Alarm Low Set Point	0x6D, 0x04, 0x02	REAL
12	0x77, 0x01, 0x0C	DINT	Profile Action Request	0x7A, 0x01, 0x0B	DINT
13	0x77, 0x01, 0x0D	DINT	Profile Start	0x7A, 0x01, 0x01	DINT
14	0x77, 0x01, 0x0E	DINT	Heat Proportional Band	0x97, 0x01, 0x06	REAL
15	0x77, 0x01, 0x0F	DINT	Cool Proportional Band	0x97, 0x01, 0x07	REAL
16	0x77, 0x01, 0x10	DINT	Time Integral	0x97, 0x01, 0x08	REAL
17	0x77, 0x01, 0x11	DINT	Time Derivative	0x97, 0x01, 0x09	REAL
18	0x77, 0x01, 0x12	DINT	Heat Hysteresis	0x97, 0x01, 0x0B	REAL
19	0x77, 0x01, 0x13	DINT	Cool Hysteresis	0x97, 0x01, 0x0C	REAL
20	0x77, 0x01, 0x14	DINT	Dead Band	0x97, 0x01, 0x0A	REAL

CIP Implicit Assembly Target (ST) to Originator (Master)					
Assembly Members	Assembly Class, Instance, Attribute	ST Data Type	Parameter	Parameter Class, Instance, Attribute	PLC Data Type
0	Cannot be changed	Binary	Device Status	none	BIN
1	0x77, 0x02, 0x01	DINT	Analog Input 1, Analog Input Value	0x68, 0x01, 0x01	REAL
2	0x77, 0x02, 0x02	DINT	Analog Input 1, Input Error	0x68, 0x01, 0x02	REAL
3	0x77, 0x02, 0x03	DINT	Analog Input 2, Analog Input Value	0x68, 0x02, 0x01	REAL
4	0x77, 0x02, 0x04	DINT	Analog Input 2, Input Error	0x68, 0x02, 0x02	REAL
5	0x77, 0x02, 0x05	DINT	Alarm 1, Alarm State	0x6D, 0x01, 0x09	DINT
6	0x77, 0x02, 0x06	DINT	Alarm 2, Alarm State	0x6D, 0x02, 0x09	DINT
7	0x77, 0x02, 0x07	DINT	Alarm 3, Alarm State	0x6D, 0x03, 0x09	DINT
8	0x77, 0x02, 0x08	DINT	Alarm 4, Alarm State	0x6D, 0x04, 0x09	DINT
9	0x77, 0x02, 0x09	DINT	Event Status	0x6E, 0x01, 0x05	DINT
10	0x77, 0x02, 0x0A	DINT	Event Status	0x6E, 0x02, 0x05	DINT
11	0x77, 0x02, 0x0B	DINT	Control Mode Active	0x97, 0x01, 0x02	DINT
12	0x77, 0x02, 0x0C	DINT	Heat Power	0x97, 0x01, 0x0D	REAL
13	0x77, 0x02, 0x0D	DINT	Cool Power	0x97, 0x01, 0x0E	REAL
14	0x77, 0x02, 0x0E	DINT	Limit State	0x70, 0x01, 0x06	DINT
15	0x77, 0x02, 0x0F	DINT	Profile Start	0x74, 0x01, 0x01	DINT
16	0x77, 0x02, 0x10	DINT	Profile Action Request	0x74, 0x01, 0x0B	DINT
17	0x77, 0x02, 0x11	DINT	Current Profile	0x74, 0x01, 0x03	DINT
18	0x77, 0x02, 0x12	DINT	Current Step	0x74, 0x01, 0x04	DINT
19	0x77, 0x02, 0x13	DINT	Active Set Point	0x74, 0x01, 0x05	REAL
20	0x77, 0x02, 0x14	DINT	Step Time Remaining	0x74, 0x01, 0x09	DINT

Note:

When configuring the gateway T to O assembly size, the maximum size is 20. The graphic above shows 21 members where the first member (0 - Device Status) is implied. When configuring the Master assembly size, Device Status cannot be omitted.

PM CIP Implicit Assemblies

CIP Implicit Assembly Originator (Master) to Target (PM)					
Assembly Members	Assembly Class, Instance, Attribute	PM Data Type	Parameter	Parameter Class, Instance, Attribute	PLC Data Type
1	0x77, 0x01, 0x01	DINT	Control Loop 1, User Control Mode	0x97, 0x01, 0x01	DINT
2	0x77, 0x01, 0x02	DINT	Closed Loop Set Point	0x6B, 0x01, 0x01	REAL
3	0x77, 0x01, 0x03	DINT	Open Loop Set Point	0x6B, 0x01, 0x02	REAL
4	0x77, 0x01, 0x04	DINT	Alarm 1 - Alarm High Set Point	0x6D, 0x01, 0x01	REAL
5	0x77, 0x01, 0x05	DINT	Alarm 1 - Alarm Low Set Point	0x6D, 0x01, 0x02	REAL
6	0x77, 0x01, 0x06	DINT	Alarm 2 - Alarm High Set Point	0x6D, 0x02, 0x01	REAL
7	0x77, 0x01, 0x07	DINT	Alarm 2 - Alarm Low Set Point	0x6D, 0x02, 0x02	REAL
8	0x77, 0x01, 0x08	DINT	Alarm 3 - Alarm High Set Point	0x6D, 0x03, 0x01	REAL
9	0x77, 0x01, 0x09	DINT	Alarm 3 - Alarm Low Set Point	0x6D, 0x03, 0x02	REAL
10	0x77, 0x01, 0x0A	DINT	Alarm 4 - Alarm High Set Point	0x6D, 0x04, 0x01	REAL
11	0x77, 0x01, 0x0B	DINT	Alarm 4 - Alarm Low Set Point	0x6D, 0x04, 0x02	REAL
12	0x77, 0x01, 0x0C	DINT	Profile Action Request	0x7A, 0x01, 0x0B	DINT
13	0x77, 0x01, 0x0D	DINT	Profile Start	0x7A, 0x01, 0x01	DINT
14	0x77, 0x01, 0x0E	DINT	Heat Proportional Band	0x97, 0x01, 0x06	REAL
15	0x77, 0x01, 0x0F	DINT	Cool Proportional Band	0x97, 0x01, 0x07	REAL
16	0x77, 0x01, 0x10	DINT	Time Integral	0x97, 0x01, 0x08	REAL
17	0x77, 0x01, 0x11	DINT	Time Derivative	0x97, 0x01, 0x09	REAL
18	0x77, 0x01, 0x12	DINT	Heat Hysteresis	0x97, 0x01, 0x0B	REAL
19	0x77, 0x01, 0x13	DINT	Cool Hysteresis	0x97, 0x01, 0x0C	REAL
20	0x77, 0x01, 0x14	DINT	Dead Band	0x97, 0x01, 0x0A	REAL

CIP Implicit Assembly Target (PM) to Originator (Master)					
Assembly Members	Assembly Class, Instance, Attribute	PM Data Type	Parameter	Parameter Class, Instance, Attribute	PLC Data Type
0	Cannot be changed	Binary	Device Status	none	BIN
1	0x77, 0x02, 0x01	DINT	Analog Input 1, Analog Input Value	0x68, 0x01, 0x01	REAL
2	0x77, 0x02, 0x02	DINT	Analog Input 1, Input Error	0x68, 0x01, 0x02	REAL
3	0x77, 0x02, 0x03	DINT	Analog Input 2, Analog Input Value	0x68, 0x02, 0x01	REAL
4	0x77, 0x02, 0x04	DINT	Analog Input 2, Input Error	0x68, 0x02, 0x02	REAL
5	0x77, 0x02, 0x05	DINT	Alarm 1, Alarm State	0x6D, 0x01, 0x09	DINT
6	0x77, 0x02, 0x06	DINT	Alarm 2, Alarm State	0x6D, 0x02, 0x09	DINT
7	0x77, 0x02, 0x07	DINT	Alarm 3, Alarm State	0x6D, 0x03, 0x09	DINT
8	0x77, 0x02, 0x08	DINT	Alarm 4, Alarm State	0x6D, 0x04, 0x09	DINT
9	0x77, 0x02, 0x09	DINT	Event Status	0x6E, 0x01, 0x05	DINT
10	0x77, 0x02, 0x0A	DINT	Event Status	0x6E, 0x02, 0x05	DINT
11	0x77, 0x02, 0x0B	DINT	Control Mode Active	0x97, 0x01, 0x02	DINT
12	0x77, 0x02, 0x0C	DINT	Heat Power	0x97, 0x01, 0x0D	REAL
13	0x77, 0x02, 0x0D	DINT	Cool Power	0x97, 0x01, 0x0E	REAL
14	0x77, 0x02, 0x0E	DINT	Limit State	0x70, 0x01, 0x06	DINT
15	0x77, 0x02, 0x0F	DINT	Profile Start	0x74, 0x01, 0x01	DINT
16	0x77, 0x02, 0x10	DINT	Profile Action Request	0x74, 0x01, 0x0B	DINT
17	0x77, 0x02, 0x11	DINT	Current Profile	0x74, 0x01, 0x03	DINT
18	0x77, 0x02, 0x12	DINT	Current Step	0x74, 0x01, 0x04	DINT
19	0x77, 0x02, 0x13	DINT	Active Set Point	0x74, 0x01, 0x05	REAL
20	0x77, 0x02, 0x14	DINT	Step Time Remaining	0x74, 0x01, 0x09	DINT

Note:

When configuring the gateway T to O assembly size, the maximum size is 20. The graphic above shows 21 members where the first member (0 - Device Status) is implied. When configuring the Master assembly size, Device Status cannot be omitted.

RME CIP Implicit Assemblies

CIP Implicit Assembly Originator (Master) to Target (RME)					
Assembly Members	Assembly Class, Instance, Attribute	RM Module Data Type	Parameter	Parameter Class, Instance, Attribute	PLC Data Type
1	0x77, 0x01, 0x01	DINT	None specified	----	----
2	0x77, 0x01, 0x02	DINT	None specified	----	----
3	0x77, 0x01, 0x03	DINT	None specified	----	----
4	0x77, 0x01, 0x04	DINT	None specified	----	----
5	0x77, 0x01, 0x05	DINT	None specified	----	----
6	0x77, 0x01, 0x06	DINT	None specified	----	----
7	0x77, 0x01, 0x07	DINT	None specified	----	----
8	0x77, 0x01, 0x08	DINT	None specified	----	----
9	0x77, 0x01, 0x09	DINT	None specified	----	----
10	0x77, 0x01, 0x0A	DINT	None specified	----	----
11	0x77, 0x01, 0x0B	DINT	None specified	----	----
12	0x77, 0x01, 0x0C	DINT	None specified	----	----
13	0x77, 0x01, 0x0D	DINT	None specified	----	----
14	0x77, 0x01, 0x0E	DINT	None specified	----	----
15	0x77, 0x01, 0x0F	DINT	None specified	----	----
16	0x77, 0x01, 0x10	DINT	None specified	----	----
17	0x77, 0x01, 0x11	DINT	None specified	----	----
18	0x77, 0x01, 0x12	DINT	None specified	----	----
19	0x77, 0x01, 0x13	DINT	None specified	----	----
20	0x77, 0x01, 0x14	DINT	None specified	----	----

CIP Implicit Assembly Target (RME) to Originator (Master)					
Assembly Members	Assembly Class, Instance, Attribute	RM Module Data Type	Parameter	Parameter Class, Instance, Attribute	PLC Data Type
0	Cannot be changed	Binary	Device Status	none	DINT
1	0x77, 0x02, 0x01	DINT	None specified	----	----
2	0x77, 0x02, 0x02	DINT	None specified	----	----
3	0x77, 0x02, 0x03	DINT	None specified	----	----
4	0x77, 0x02, 0x04	DINT	None specified	----	----
5	0x77, 0x02, 0x05	DINT	None specified	----	----
6	0x77, 0x02, 0x06	DINT	None specified	----	----
7	0x77, 0x02, 0x07	DINT	None specified	----	----
8	0x77, 0x02, 0x08	DINT	None specified	----	----
9	0x77, 0x02, 0x09	DINT	None specified	----	----
10	0x77, 0x02, 0x0A	DINT	None specified	----	----
11	0x77, 0x02, 0x0B	DINT	None specified	----	----
12	0x77, 0x02, 0x0C	DINT	None specified	----	----
13	0x77, 0x02, 0x0D	DINT	None specified	----	----
14	0x77, 0x02, 0x0E	DINT	None specified	----	----
15	0x77, 0x02, 0x0F	DINT	None specified	----	----
16	0x77, 0x02, 0x10	DINT	None specified	----	----
17	0x77, 0x02, 0x11	DINT	None specified	----	----
18	0x77, 0x02, 0x12	DINT	None specified	----	----
19	0x77, 0x02, 0x13	DINT	None specified	----	----
20	0x77, 0x02, 0x14	DINT	None specified	----	----

RMC CIP Implicit Assemblies

RMC CIP 0 to T Implicit Assemblies

CIP Implicit Assembly Originator (Master) to Target (RMC)					
Assembly Members	Assembly Class, Instance, Attribute	RM Module Data Type	Parameter	Parameter Class, Instance, Attribute	PLC Data Type
1	0x77, 0x01, 0x01	DINT	Control Loop 1, Closed Loop Set Point	0x6B, 0x01, 0x01	REAL
2	0x77, 0x01, 0x02	DINT	Control Loop 2, Closed Loop Set Point	0x6B, 0x02, 0x01	REAL
3	0x77, 0x01, 0x03	DINT	Control Loop 3, Closed Loop Set Point	0x6B, 0x03, 0x01	REAL
4	0x77, 0x01, 0x04	DINT	Control Loop 4, Closed Loop Set Point	0x6B, 0x04, 0x01	REAL
5	0x77, 0x01, 0x05	DINT	Control Loop 1, Open Loop Set Point	0x6B, 0x01, 0x02	REAL
6	0x77, 0x01, 0x06	DINT	Control Loop 2, Open Loop Set Point	0x6B, 0x02, 0x02	REAL
7	0x77, 0x01, 0x07	DINT	Control Loop 3, Open Loop Set Point	0x6B, 0x03, 0x02	REAL
8	0x77, 0x01, 0x08	DINT	Control Loop 4, Open Loop Set Point	0x6B, 0x04, 0x02	REAL
9	0x77, 0x01, 0x09	DINT	Control Loop 1, User Control Mode	0x97, 0x01, 0x02	DINT
10	0x77, 0x01, 0x0A	DINT	Control Loop 2, User Control Mode	0x97, 0x02, 0x02	DINT
11	0x77, 0x01, 0x0B	DINT	Control Loop 3, User Control Mode	0x97, 0x03, 0x02	DINT
12	0x77, 0x01, 0x0C	DINT	Control Loop 4, User Control Mode	0x97, 0x04, 0x02	DINT
13	0x77, 0x01, 0x0D	DINT	Alarm 1, Alarm High Set Point	0x6D, 0x01, 0x01	REAL
14	0x77, 0x01, 0x0E	DINT	Alarm 2, Alarm High Set Point	0x6D, 0x02, 0x01	REAL
15	0x77, 0x01, 0x0F	DINT	Alarm 3, Alarm High Set Point	0x6D, 0x03, 0x01	REAL
16	0x77, 0x01, 0x10	DINT	Alarm 4, Alarm High Set Point	0x6D, 0x04, 0x01	REAL
17	0x77, 0x01, 0x11	DINT	Alarm 1, Alarm Low Set Point	0x6D, 0x05, 0x01	REAL
18	0x77, 0x01, 0x12	DINT	Alarm 2, Alarm Low Set Point	0x6D, 0x06, 0x01	REAL
19	0x77, 0x01, 0x13	DINT	Alarm 3, Alarm Low Set Point	0x6D, 0x07, 0x01	REAL
20	0x77, 0x01, 0x14	DINT	Alarm 4, Alarm Low Set Point	0x6D, 0x08, 0x01	REAL
21	0x77, 0x02, 0x15	DINT	None Specified	----	----
22	0x77, 0x02, 0x16	DINT	None Specified	----	----
23	0x77, 0x02, 0x17	DINT	None Specified	----	----
24	0x77, 0x02, 0x18	DINT	None Specified	----	----
25	0x77, 0x02, 0x19	DINT	None Specified	----	----
26	0x77, 0x02, 0x1A	DINT	None Specified	----	----
27	0x77, 0x02, 0x1B	DINT	None Specified	----	----
28	0x77, 0x02, 0x1C	DINT	None Specified	----	----
29	0x77, 0x02, 0x1D	DINT	None Specified	----	----
30	0x77, 0x02, 0x1E	DINT	None Specified	----	----
31	0x77, 0x02, 0x1F	DINT	None Specified	----	----
32	0x77, 0x02, 0x20	DINT	None Specified	----	----
33	0x77, 0x02, 0x21	DINT	None Specified	----	----
34	0x77, 0x02, 0x22	DINT	None Specified	----	----
35	0x77, 0x02, 0x23	DINT	None Specified	----	----
36	0x77, 0x02, 0x24	DINT	None Specified	----	----
37	0x77, 0x02, 0x25	DINT	None Specified	----	----
38	0x77, 0x02, 0x26	DINT	None Specified	----	----
39	0x77, 0x02, 0x27	DINT	None Specified	----	----
40	0x77, 0x02, 0x28	DINT	None Specified	----	----

Note:

Although 40 members are built into this module the RUI allows for a maximum of 20.

RMC CIP T to O Implicit Assemblies

CIP Implicit Assembly Target (RMC) to Originator (Master)					
Assembly Members	Assembly Class, Instance, Attribute	RM Module Data Type	Parameter	Parameter Class, Instance, Attribute	PLC Data Type
0	Cannot be changed	Binary	Device Status	none	DINT
1	0x77, 0x02, 0x01	DINT	Analog Input 1, Analog Input Value (filtered)	0x68, 0x01, 0x01	REAL
2	0x77, 0x02, 0x02	DINT	Analog Input 1, Input Error	0x68, 0x01, 0x02	DINT
3	0x77, 0x02, 0x03	DINT	Analog Input 2, Analog Input Value (filtered)	0x68, 0x02, 0x01	REAL
4	0x77, 0x02, 0x04	DINT	Analog Input 2, Input Error	0x68, 0x02, 0x02	DINT
5	0x77, 0x02, 0x05	DINT	Analog Input 3, Analog Input Value (filtered)	0x68, 0x03, 0x01	REAL
6	0x77, 0x02, 0x06	DINT	Analog Input 3, Input Error	0x68, 0x03, 0x02	DINT
7	0x77, 0x02, 0x07	DINT	Analog Input 4, Analog Input Value (filtered)	0x68, 0x04, 0x01	REAL
8	0x77, 0x02, 0x08	DINT	Analog Input 4, Input Error	0x68, 0x04, 0x02	DINT
9	0x77, 0x02, 0x09	DINT	Alarm 1, Alarm State	0x6D, 0x01, 0x09	DINT
10	0x77, 0x02, 0x0A	DINT	Alarm 2, Alarm State	0x6D, 0x02, 0x09	DINT
11	0x77, 0x02, 0x0B	DINT	Alarm 3, Alarm State	0x6D, 0x03, 0x09	DINT
12	0x77, 0x02, 0x0C	DINT	Alarm 4, Alarm State	0x6D, 0x04, 0x09	DINT
13	0x77, 0x02, 0x0D	DINT	Alarm 5, Alarm State	0x6D, 0x05, 0x09	DINT
14	0x77, 0x02, 0x0E	DINT	Alarm 6, Alarm State	0x6D, 0x06, 0x09	DINT
15	0x77, 0x02, 0x0F	DINT	Alarm 7, Alarm State	0x6D, 0x07, 0x09	DINT
16	0x77, 0x02, 0x10	DINT	Alarm 8, Alarm State	0x6D, 0x08, 0x09	DINT
17	0x77, 0x02, 0x11	DINT	Control Loop 1, Output Power	0x97, 0x01, 0x0F	REAL
18	0x77, 0x02, 0x12	DINT	Control Loop 2, Output Power	0x97, 0x02, 0x0F	REAL
19	0x77, 0x02, 0x13	DINT	Control Loop 3, Output Power	0x97, 0x03, 0x0F	REAL
20	0x77, 0x02, 0x14	DINT	Control Loop 4, Output Power	0x97, 0x04, 0x0F	REAL
21	0x77, 0x02, 0x15	DINT	None Specified	----	----
22	0x77, 0x02, 0x16	DINT	None Specified	----	----
23	0x77, 0x02, 0x17	DINT	None Specified	----	----
24	0x77, 0x02, 0x18	DINT	None Specified	----	----
25	0x77, 0x02, 0x19	DINT	None Specified	----	----
26	0x77, 0x02, 0x1A	DINT	None Specified	----	----
27	0x77, 0x02, 0x1B	DINT	None Specified	----	----
28	0x77, 0x02, 0x1C	DINT	None Specified	----	----
29	0x77, 0x02, 0x1D	DINT	None Specified	----	----
30	0x77, 0x02, 0x1E	DINT	None Specified	----	----
31	0x77, 0x02, 0x1F	DINT	None Specified	----	----
32	0x77, 0x02, 0x20	DINT	None Specified	----	----
33	0x77, 0x02, 0x21	DINT	None Specified	----	----
34	0x77, 0x02, 0x22	DINT	None Specified	----	----
35	0x77, 0x02, 0x23	DINT	None Specified	----	----
36	0x77, 0x02, 0x24	DINT	None Specified	----	----
37	0x77, 0x02, 0x25	DINT	None Specified	----	----
38	0x77, 0x02, 0x26	DINT	None Specified	----	----
39	0x77, 0x02, 0x27	DINT	None Specified	----	----
40	0x77, 0x02, 0x28	DINT	None Specified	----	----

Note:

When configuring the gateway T to O assembly size for the RMC, the maximum size is using the RUI is 20. The graphic above shows 41 members where the first member (0 - Device Status) is implied. When configuring the Master assembly size, Device Status cannot be omitted.

RMH, RMS and RML CIP Implicit Assemblies

RMH, RMS and RML O to T CIP Implicit Assemblies

CIP Implicit Assembly Originator (Master) to Target (RMH / RMS / RML)					
Assembly Members	Assembly Class, Instance, Attribute	RM Module Data Type	Parameter	Parameter Class, Instance, Attribute	PLC Data Type
1	0x77, 0x01, 0x01	DINT	None specified	----	----
2	0x77, 0x01, 0x02	DINT	None specified	----	----
3	0x77, 0x01, 0x03	DINT	None specified	----	----
4	0x77, 0x01, 0x04	DINT	None specified	----	----
5	0x77, 0x01, 0x05	DINT	None specified	----	----
6	0x77, 0x01, 0x06	DINT	None specified	----	----
7	0x77, 0x01, 0x07	DINT	None specified	----	----
8	0x77, 0x01, 0x08	DINT	None specified	----	----
9	0x77, 0x01, 0x09	DINT	None specified	----	----
10	0x77, 0x01, 0x0A	DINT	None specified	----	----
11	0x77, 0x01, 0x0B	DINT	None specified	----	----
12	0x77, 0x01, 0x0C	DINT	None specified	----	----
13	0x77, 0x01, 0x0D	DINT	None specified	----	----
14	0x77, 0x01, 0x0E	DINT	None specified	----	----
15	0x77, 0x01, 0x0F	DINT	None specified	----	----
16	0x77, 0x01, 0x10	DINT	None specified	----	----
17	0x77, 0x01, 0x11	DINT	None specified	----	----
18	0x77, 0x01, 0x12	DINT	None specified	----	----
19	0x77, 0x01, 0x13	DINT	None specified	----	----
20	0x77, 0x01, 0x14	DINT	None specified	----	----
21	0x77, 0x01, 0x15	DINT	None specified	----	----
22	0x77, 0x01, 0x16	DINT	None specified	----	----
23	0x77, 0x01, 0x17	DINT	None specified	----	----
24	0x77, 0x01, 0x18	DINT	None specified	----	----
25	0x77, 0x01, 0x19	DINT	None specified	----	----
26	0x77, 0x01, 0x1A	DINT	None specified	----	----
27	0x77, 0x01, 0x1B	DINT	None specified	----	----
28	0x77, 0x01, 0x1C	DINT	None specified	----	----
29	0x77, 0x01, 0x1D	DINT	None specified	----	----
30	0x77, 0x01, 0x1E	DINT	None specified	----	----
31	0x77, 0x01, 0x1F	DINT	None specified	----	----
32	0x77, 0x01, 0x20	DINT	None specified	----	----
33	0x77, 0x01, 0x21	DINT	None specified	----	----
34	0x77, 0x01, 0x22	DINT	None specified	----	----
35	0x77, 0x01, 0x23	DINT	None specified	----	----
36	0x77, 0x01, 0x24	DINT	None specified	----	----
37	0x77, 0x01, 0x25	DINT	None specified	----	----
38	0x77, 0x01, 0x26	DINT	None specified	----	----
39	0x77, 0x01, 0x27	DINT	None specified	----	----
40	0x77, 0x01, 0x28	DINT	None specified	----	----

RMH, RMS and RML T to O CIP Implicit Assemblies

CIP Implicit Assembly					
Target (RMH / RMS / RML) to Originator (Master)					
Assembly Members	Assembly Class, Instance, Attribute	RM Module Data Type	Parameter	Parameter Class, Instance, Attribute	PLC Data Type
0	Cannot be changed	Binary	Device Status	none	DINT
1	0x77, 0x02, 0x01	DINT	None specified	----	----
2	0x77, 0x02, 0x02	DINT	None specified	----	----
3	0x77, 0x02, 0x03	DINT	None specified	----	----
4	0x77, 0x02, 0x04	DINT	None specified	----	----
5	0x77, 0x02, 0x05	DINT	None specified	----	----
6	0x77, 0x02, 0x06	DINT	None specified	----	----
7	0x77, 0x02, 0x07	DINT	None specified	----	----
8	0x77, 0x02, 0x08	DINT	None specified	----	----
9	0x77, 0x02, 0x09	DINT	None specified	----	----
10	0x77, 0x02, 0x0A	DINT	None specified	----	----
11	0x77, 0x02, 0x0B	DINT	None specified	----	----
12	0x77, 0x02, 0x0C	DINT	None specified	----	----
13	0x77, 0x02, 0x0D	DINT	None specified	----	----
14	0x77, 0x02, 0x0E	DINT	None specified	----	----
15	0x77, 0x02, 0x0F	DINT	None specified	----	----
16	0x77, 0x02, 0x10	DINT	None specified	----	----
17	0x77, 0x02, 0x11	DINT	None specified	----	----
18	0x77, 0x02, 0x12	DINT	None specified	----	----
19	0x77, 0x02, 0x13	DINT	None specified	----	----
20	0x77, 0x02, 0x14	DINT	None specified	----	----
21	0x77, 0x02, 0x15	DINT	None specified	----	----
22	0x77, 0x02, 0x16	DINT	None specified	----	----
23	0x77, 0x02, 0x17	DINT	None specified	----	----
24	0x77, 0x02, 0x18	DINT	None specified	----	----
25	0x77, 0x02, 0x19	DINT	None specified	----	----
26	0x77, 0x02, 0x1A	DINT	None specified	----	----
27	0x77, 0x02, 0x1B	DINT	None specified	----	----
28	0x77, 0x02, 0x1C	DINT	None specified	----	----
29	0x77, 0x02, 0x1D	DINT	None specified	----	----
30	0x77, 0x02, 0x1E	DINT	None specified	----	----
31	0x77, 0x02, 0x1F	DINT	None specified	----	----
32	0x77, 0x02, 0x20	DINT	None specified	----	----
33	0x77, 0x02, 0x21	DINT	None specified	----	----
34	0x77, 0x02, 0x22	DINT	None specified	----	----
35	0x77, 0x02, 0x23	DINT	None specified	----	----
36	0x77, 0x02, 0x24	DINT	None specified	----	----
37	0x77, 0x02, 0x25	DINT	None specified	----	----
38	0x77, 0x02, 0x26	DINT	None specified	----	----
39	0x77, 0x02, 0x27	DINT	None specified	----	----
40	0x77, 0x02, 0x28	DINT	None specified	----	----

Note:

When configuring the gateway T to O assembly size for the RMH, RMS and RML, the maximum size using the RUI is 20. The graphic above shows 41 members where the first member (0 - Device Status) is implied. When configuring the Master assembly size, Device Status cannot be omitted.

Specifications

Basic Remote User Interface (RUI)

Operator Interface

- Dual 4-digit, 7-segment LED displays
- Forward, backward, up and down keys plus a customer programmable function key
- Typical display update rate 1Hz
- Agency approved to IP65/NEMA 4X (indoor use only)
- Standard Bus protocol ships with all units
- Optional Communications Protocols:
 - EIA 232/485 Modbus RTU
 - EtherNet/IP and Modbus TCP
 - DeviceNet
 - Profibus DP

Line Voltage/Power

- 85 to 264V~ (ac), 47 to 63Hz, 10VA maximum
- 20 to 28V≈ (ac/dc), 47 to 63Hz

Environment

- -18 to 65°C ambient
- -40 to 80°C shipping and storage

Dimensions

Size	Behind Panel (max.)	Width	Height	Display Height
Long Case	101.6 mm (4.00 in)	53.3 mm (2.10 in)	53.3 mm (2.10 in)	up: 10.80 mm (0.425 in) low: 6.98 mm (0.275 in)
Short Case	59.1 mm (2.33 in)	53.3 mm (2.10 in)	53.3 mm (2.10 in)	up: 10.80 mm (0.425 in) low: 6.98 mm (0.275 in)

Weight

- Controller (short case): 99.8 g (0.22 lb)
- Controller (long case): 162.5 g (0.36 lb)

Modbus® is a trademark of AEG Schneider Automation Inc.

EtherNet/IP™ is a trademark of ControlNet International Ltd. used under license by Open DeviceNet™ Vendor Association, Inc. (ODVA).

UL® is a registered trademark of Underwriters Laboratories Inc.

DeviceNet™ is a trademark of Open DeviceNet™ Vendors Association.

Note:

These specifications are subject to change without prior notice.

Ordering Information

EZ-ZONE® Remote Users Interface E Z K - - - - - - - - - -

Remote User Interface (RUI)

B Basic 1/16 DIN

Power Supply Voltage for Remote User Interface (RUI)

L Low voltage 24 to 28V \approx (ac/dc)

H Universal high voltage 100 to 240V \approx (ac/dc)

Communications Options (Standard Bus always included)

A None (short case)

2 EIA 232/485 Modbus® RTU (long case)

3 EtherNet/IP™ Modbus TCP (long case)

5 DeviceNet™ (long case)

6 Profibus DP (long case)

Custom Remote User Interface (RUI)

AA None

XX Custom options, consult factory

Future Option

A None

Future Option

A None

Future Option

AA None

Note:

Configurator PC software can be downloaded for free from the Watlow website:

http://www.watlow.com/products/software/zone_config.cfm

Declaration of Conformity

Series EZ-ZONE[®] RUI



WATLOW

1241 Bundy Blvd.
Winona, MN 55987 USA

an ISO 9001 approved facility since 1996.

Declares that the following product:

Designation: **Series EZ-ZONE[®] RUI**
Model Numbers: EZK (A, B, C, D or E) (A, L or H) (any three numbers or letters) A, A,
(any two letters or numbers)
Classification: Temperature control, Installation Category II, Pollution degree 2
IP66 Environmental seal on front panel.
Rated Voltage and Frequency: Control 100 to 240 V~ (ac 50/60 Hz) **or** 24 to 28 V~ (ac 50/60 Hz or dc)
Rated Power Consumption: 10 VA

Meets the essential requirements of the following European Union Directives by using the relevant standards show below to indicate compliance.

2004/108/EC Electromagnetic Compatibility Directive

EN 61326-1	2006	Electrical equipment for measurement, control and laboratory use – EMC requirements (Industrial Immunity, EZK - _A models are Class A emissions. <i>Not for use in a Class B environment without additional filtering</i>), All other models are Class B emissions.
EN 61000-4-2	1996 +A1,A2	Electrostatic Discharge Immunity
EN 61000-4-3	2006	Radiated Field Immunity
EN 61000-4-4	2004	Electrical Fast-Transient / Burst Immunity
EN 61000-4-5	2006	Surge Immunity
EN 61000-4-6	1996 +A1,A2,A3	Conducted Immunity
EN 61000-4-8	1994 +A1:2001	Magnetic Field Immunity
EN 61000-4-11	2004	Voltage Dips, Short Interruptions and Voltage Variations Immunity
EN 61000-3-2	2006	Harmonic Current Emissions
EN 61000-3-3	2005	Voltage Fluctuations and Flicker
SEMI F47	2000	Specification for Semiconductor Sag Immunity Figure R1-1

2006/95/EC Low-Voltage Directive

EN 61010-1 2001 Safety Requirements of electrical equipment for measurement, control and laboratory use. Part 1: General requirements

Compliant with 2002/95/EC RoHS Directive

Per 2002/96/EC WEEE Directive  Please Recycle Properly

Raymond D. Feller III
Name of Authorized Representative

Winona, Minnesota, USA
Place of Issue

General Manager
Title of Authorized Representative

June 2009
Date of Issue

Signature of Authorized Representative

CE DOC EZ-ZONE RUI-06-09

How to Reach Us

Corporate Headquarters

Watlow Electric Manufacturing Company
12001 Lackland Road
St. Louis, MO 63146
Sales: 1-800-WATLOW2
Manufacturing Support: 1-800-4WATLOW
Email: info@watlow.com
Website: www.watlow.com
From outside the USA and Canada:
Tel: +1 (314) 878-4600
Fax: +1 (314) 878-6814

Latin America

Watlow de México S.A. de C.V.
Av. Fundación No. 5
Col. Parques Industriales
Querétaro, Qro. CP-76130
Mexico
Tel: +52 442 217-6235
Fax: +52 442 217-6403

Europe

Watlow France
Tour d'Asnières.
4 Avenue Laurent Cély
92600 Asnières sur Seine
France
Tél: + 33 (0)1 41 32 79 70
Télécopie: + 33(0)1 47 33 36 57
Email: info@watlow.fr
Website: www.watlow.fr

Watlow GmbH
Postfach 11 65, Lauchwasenstr. 1
D-76709 Kronau
Germany
Tel: +49 (0) 7253 9400-0
Fax: +49 (0) 7253 9400-900
Email: info@watlow.de
Website: www.watlow.de

Watlow Italy S.r.l.
Viale Italia 52/54
20094 Corsico MI
Italy
Tel: +39 024588841
Fax: +39 0245869954
Email: italyinfo@watlow.com
Website: www.watlow.it

Watlow Ibérica, S.L.U.
C/Marte 12, Posterior, Local 9
E-28850 Torrejón de Ardoz
Madrid - Spain
T. +34 91 675 12 92
F. +34 91 648 73 80
Email: info@watlow.es
Website: www.watlow.es

Watlow UK Ltd.
Linby Industrial Estate
Linby, Nottingham, NG15 8AA
United Kingdom
Telephone: (0) 115 964 0777
Fax: (0) 115 964 0071
Email: info@watlow.co.uk
Website: www.watlow.co.uk
From outside The United Kingdom:
Tel: +44 115 964 0777
Fax: +44 115 964 0071

Asia and Pacific

Watlow Singapore Pte Ltd.
16 Ayer Rajah Crescent,
#06-03/04,
Singapore 139965
Tel: +65 6773 9488 Fax: +65 6778 0323
Email: info@watlow.com.sg Website: www.watlow.com.sg

Watlow Australia Pty., Ltd.
4/57 Sharps Road
Tullamarine, VIC 3043
Australia
Tel: +61 3 9335 6449
Fax: +61 3 9330 3566
Website: www.watlow.com

Watlow Electric Manufacturing (Shanghai) Company
1118 Fangyuan Road, Anting Industrial Park, Jiading, Shanghai, PRC
201203
People's Republic of China
Tel: +86 21 39509510
Fax: +86 21 5080-0906
Email: info@watlow.cn
Website: www.watlow.cn

ワトロー・ジャパン株式会社
〒101-0047 東京都千代田区内神田1-14-4
四国ビル別館9階
Tel: 03-3518-6630 Fax: 03-3518-6632
Email: infoj@watlow.com Website: www.watlow.co.jp

Watlow Japan Ltd.
1-14-4 Uchikanda, Chiyoda-Ku
Tokyo 101-0047
Japan
Tel: +81-3-3518-6630 Fax: +81-3-3518-6632
Email: infoj@watlow.com Website: www.watlow.co.jp

Watlow Korea Co., Ltd.
#1406, E&C Dream Tower, 46, Yangpyeongdong-3ga
Yeongdeungpo-gu, Seoul 150-103
Republic of Korea
Tel: +82 (2) 2628-5770 Fax: +82 (2) 2628-5771
Website: www.watlow.co.kr

Watlow Malaysia Sdn Bhd
No. 14-3 Jalan 2/114
Kuchai Business Centre
Jalan Kuchai Lama
58200 Kuala Lumpur
Malaysia
Tel: +60 3 7980 7741 Fax: +60 3 7980 7739

瓦特龍電機股份有限公司
80143 高雄市前金區七賢二路189號 10樓之一
電話: 07-2885168 傳真: 07-2885568

Watlow Electric Taiwan Corporation
10F-1 No.189 Chi-Shen 2nd Road Kaohsiung 80143
Taiwan
Tel: +886-7-2885168 Fax: +886-7-2885568

Your Authorized Watlow Distributor

