

## Improves Safety and Uptime in Semiconductor Sub Fabs

Hazardous gases in semiconductor fab exhaust lines can be explosive, corrosive or pyrophoric unless they are diluted to a safe range with nitrogen. Adding Watlow's FLUENT® thermal system to the exhaust lines of the abatement system can improve safety and uptime ultimately leading to higher yields.

Watlow's FLUENT heater features an integrated high limit and protects the heater in low flow or no flow conditions. The FLUENT heater's "no leak" design ensures the lower explosive limit is properly maintained and nitrogen is not escaping into the sub fab.

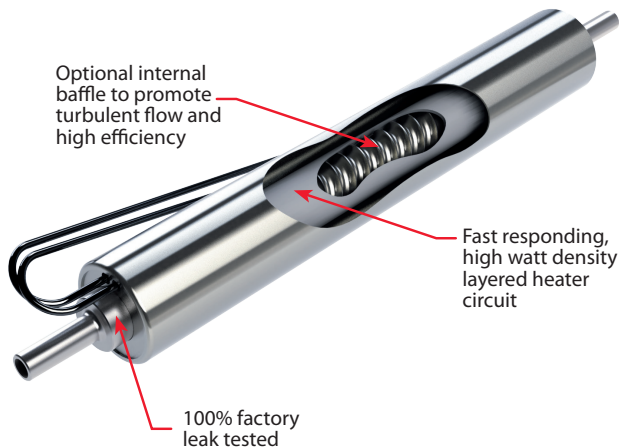

### \* Optional Location for N<sub>2</sub> Injection

The FLUENT's heating element is created using Watlow's patented thermal spray technology and makes use of its entire surface to produce heat, which optimizes heat transfer and temperature uniformity. The heating element sits outside of the fluid flow path and the heater circuit is patterned precisely and repeatably leading to excellent reliability.

The heating system also features Watlow's F4T® controller with a 4.3-inch color, graphical touch-screen panel. The controller is modular and scalable and offers intuitive navigation, integrated functions and screen personalization. Other Watlow controllers are also available.

## Features and Benefits

Heater assembly is 100% leak tested

- > Assures appropriate dilution

Internal heater baffle

- > Promotes turbulent flow
- > Assures gas is at temperature

High-limit control loop

- > Prevents heater failure in a no-flow condition
- > Meets most electrical codes

Small size

- > Enables placement at point of use

## Primary Applications

- > Dilution of hydrogenated gases in exhaust streams to levels below the lower explosive limit
- > Dilution of corrosive gases to lower levels of corrosion
- > Dilution of pyrophoric gases to levels below the lower flammability levels
- > Aid to the heating of exhaust lines where the potential for deposition is high and external heat on the exhaust lines is not enough

## Watlow's F4T® Control Panel

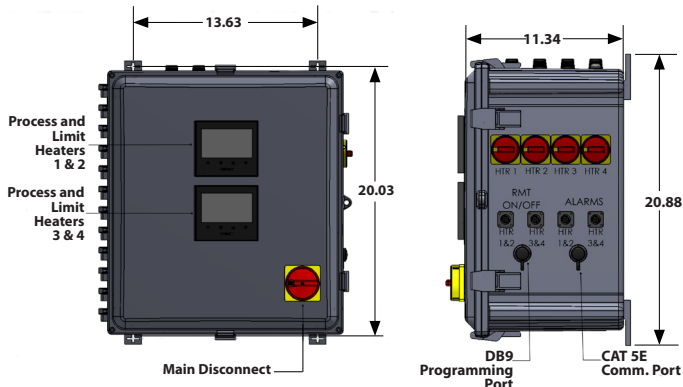

## Watlow's FLUENT Heater

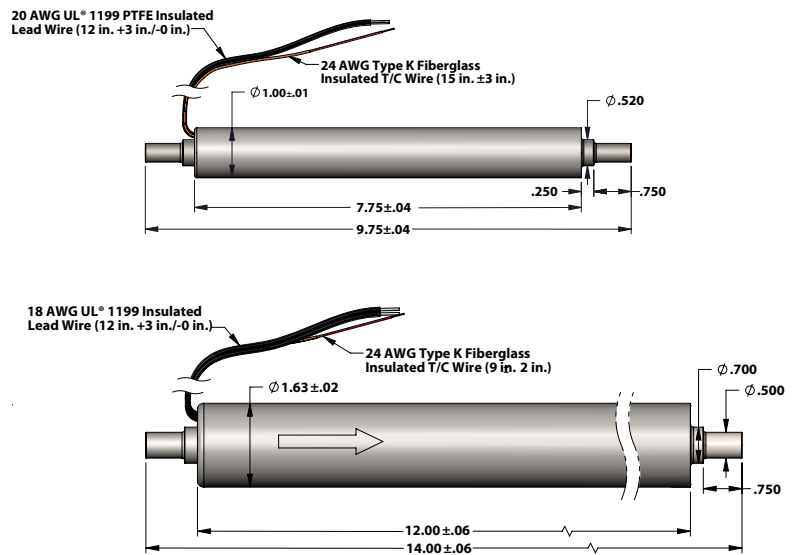

## FLUENT Thermal System Matrix

System Part Number with F4T® Controller	Number of Heaters/ Exhaust Lines	Max N <sub>2</sub> Flow Rate (slm)	Maximum N <sub>2</sub> Process Temperature (°C)	Wattage Per Heater	Compression Fitting Size
2124-5306	2	150	180	750	3/8 in.
2124-5311	4	150	180	750	3/8 in.
2124-5322	6	150	180	750	3/8 in.
2124-5333	2	400	250	2500	1/2 in.
2124-5340	4	400	250	2500	1/2 in.
2124-5354	6	400	250	2500	1/2 in.

Watlow® and FLUENT® are registered trademarks of Watlow Electric Manufacturing Company.

UL® is a registered trademark of Underwriter's Laboratories, Inc.

Powered by Possibility

To be automatically connected to the nearest North American Technical Sales Office:

1-800-WATLOW2 • [www.watlow.com](http://www.watlow.com)

International Technical Sales Offices:

Austria	+43 6244 20129 0	India	+91 40 6661 2700
China	+86 21 3532 8532	Italy	+39 02 458 8841
France	+33 1 41 32 79 70	Japan	+81 3 3518 6630
Germany	+49 7253 9400 0	Korea	+82 2 2169 2600

WATLOW

Mexico	+52 442 256 2200
Singapore	+65 6773 9488
Spain	+34 91 675 1292
Taiwan	+886 7 288 5168
UK	+44 115 964 0777